

Service Manual

Multi-Function printer

Model No. **KX-MB2000HXB**
KX-MB2010HXB

(for Czech, Hungary and Slovakia)

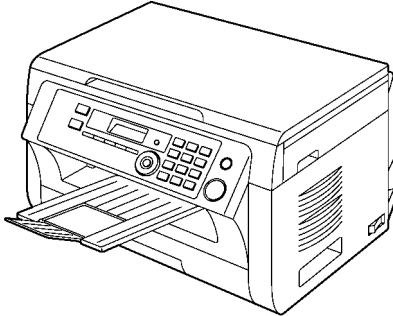

This pictured model is KX-MB2000.

⚠ WARNING

This service information is designed for experienced repair technicians only and is not designed for use by the general public. It does not contain warnings or cautions to advise non-technical individuals of potential dangers in attempting to service a product. Products powered by electricity should be serviced or repaired only by experienced professional technicians. Any attempt to service or repair the product or products dealt with in this service information by anyone else could result in serious injury or death.

IMPORTANT SAFETY NOTICE

There are special components used in this equipment which are important for safety. These parts are marked by ⚠ in the Schematic Diagrams, Circuit Board Diagrams, Exploded Views and Replacements Parts List. It is essential that these critical parts should be replaced with manufacturer's specified parts to prevent shock, fire or other hazards. Do not modify the original design without permission of manufacturer.

IMPORTANT INFORMATION ABOUT LEAD FREE, (PbF), SOLDERING

If lead free solder was used in the manufacture of this product, the printed circuit boards will be marked PbF. Standard leaded, (Pb), solder can be used as usual on boards without the PbF mark.

When this mark does appear please read and follow the special instructions described in this manual on the use of PbF and how it might be permissible to use Pb solder during service and repair work.

When you note the serial number, write down all 11 digits. The serial number may be found on the bottom of the unit.

Panasonic®

© Panasonic System Networks Co., Ltd. 2010
Unauthorized copying and distribution is a violation
of law.

TABLE OF CONTENTS

	PAGE		PAGE
1 Safety Precautions	5	6.10.5. Read Position Sensor (KX-MB2010 ONLY).....	43
1.1. For Service Technicians	5	6.10.6. Registration & Manual Paper Sensor	44
1.2. AC Caution.....	5	6.10.7. Print Timing Sensor	44
1.3. Personal Safety Precautions	6	6.10.8. Document Sensor (KX-MB2010 ONLY).....	45
1.3.1. Moving Sections of the Unit.....	6	6.10.9. Top Cover Sensor.....	45
1.3.2. Live Electrical Sections	6	6.10.10. Toner Sensor... “Toner Empty”, “Toner Low”, “Change Drum”.....	46
1.4. Service Precautions	6	6.11. Operation Board Section	49
1.4.1. Precautions to Prevent Damage from Static Electricity	6	6.12. LCD Section.....	50
2 Warning	7	6.13. HVPS (High Voltage Power Supply) Section	51
2.1. About Lead Free Solder (PbF: Pb free)	7	6.13.1. HVPS Specification.....	51
2.1.1. Suggested PbF Solder.....	7	6.13.2. CHG-BIAS (Charge BIAS)/GRID/ UNIT.....	51
2.2. Discarding of P. C. Board	8	6.13.3. DEV DC BIAS UNIT.....	52
2.3. Insulation Resistance Test.....	8	6.13.4. DEV AC BIAS UNIT.....	52
2.4. Battery Caution	8	6.13.5. TRA (+) BIAS (Transfer (+) BIAS)/TRA (-) BIAS (Transfer (-) BIAS) UNIT.....	52
2.4.1. Information for Users on Collection and Disposal of Old Equipment and used Batteries	8	6.14. Heat Lamp Control Circuit.....	53
2.5. Laser Beam And Fuser Unit Section.....	9	6.15. Main Board Section	58
2.6. Note for Repairing.....	9	6.16. Power Supply Board Section	61
3 Specifications	10	6.17. Mechanical Operation	62
4 General/Introduction	11	6.17.1. Printing	62
4.1. Optional Accessories.....	11	6.17.2. Scanning (ADF) (KX-MB2010 ONLY)	63
4.2. Translation Lists	11	7 Location of Controls and Components	64
4.2.1. Error Message (Display).....	11	7.1. Overview.....	64
5 Features	12	7.1.1. Front view.....	64
5.1. General Features.....	12	7.1.2. Rear view	64
5.2. Hardware Requirements for Multi-Function Software	12	7.2. Control Panel	65
6 Technical Descriptions	13	8 Installation Instructions	66
6.1. Connection Diagram.....	13	8.1. Installation	66
6.2. General Block Diagram.....	14	8.1.1. Installation Space	66
6.3. Main Board Section.....	16	8.1.2. OUTPUT TRAY.....	67
6.3.1. Data Flow.....	16	8.1.3. RECORDING PAPER.....	68
6.3.2. RTC Backup Circuit.....	24	8.1.4. Documents the Unit Can Send	71
6.4. CIS Control Section.....	25	8.1.5. Toner Cartridge and the Drum Cartridge.....	72
6.5. Motor Drive Section.....	26	8.1.6. Connecting to a computer	76
6.5.1. Engine Motor Control Circuit	26	8.1.7. Installing Multi-Function Station	76
6.5.2. Scanner Motor Drive Circuit	27	8.2. Connections.....	78
6.6. Timing chart and wave form of scanner motors.....	31	9 Operating Instructions	79
6.6.1. Normal 1-2 phase excitation (half step).....	31	9.1. To Select Characters with the Dial Keypad	79
6.6.2. Flat torque 1-2 phase excitation (half step).....	32	9.2. To Select Characters Using [] or []	79
6.6.3. W1-2 phase excitation (Quarter step).....	33	10 Test Mode	80
6.6.4. Drive mode of FB and ADF motor.....	34	10.1. Test Functions	80
6.7. FAN Motor Section.....	34	10.1.1. Button Code Table.....	81
6.7.1. General	34	10.1.2. Print Test Pattern.....	82
6.7.2. Circuit Diagram of FAN	35	11 Service Mode	83
6.7.3. Fan Control	35	11.1. Programming and Lists.....	83
6.7.4. Control table	36	11.1.1. Operation	83
6.7.5. Waveform.....	36	11.1.2. Operation Flow	83
6.8. Solenoid Driver Section	37	11.1.3. Service Function Table	84
6.9. LSU (Laser Scanning Unit) Section	38	11.1.4. Memory Clear Specification	84
6.10. Sensors and Switches Section	40	11.2. User Mode (The list below is an example of the SYSTEM SETUP LIST the unit prints out.) ..	85
6.10.1. Drum Detection	41	11.3. History (Example of a printed out list)	87
6.10.2. Pickup Sensor.....	41	11.3.1. Descriptions of The History Report.....	88
6.10.3. Exit Sensor.....	42	12 Troubleshooting Guide	89
6.10.4. Home Sensor.....	42	12.1. User Recoverable Errors	89
		12.2. Troubleshooting Details.....	91

12.2.1. Outline	91	15.1. Maintenance Items and Component Locations-	186
12.2.2. Starting Troubleshooting	91	15.1.1. Outline	186
12.2.3. Initialization	92	15.1.2. Maintenance Check Items/Component Locations	186
12.2.4. Simple Check List	93	15.2. Maintenance	188
12.2.5. Simplified Troubleshooting Guide	94	15.2.1. Cleaning the white plates and glass	188
12.2.6. CALL SERVICE Troubleshooting Guide	97	15.2.2. CLEANING THE DOCUMENT FEEDER ROLLERS (KX-MB2010 ONLY)	192
12.2.7. Print	104	15.3. Printing Operation Principle	193
12.2.8. Recording Paper Feed	110	15.3.1. Process Chart and Process BIAS	193
12.2.9. ADF (Auto Document Feeder) Section (KX-MB2010 ONLY)	116	15.3.2. CHARGING	193
12.2.10. Initializing Error	122	15.3.3. Exposing	194
12.2.11. Operation Panel Section	123	15.3.4. Developing and Transcription	195
12.2.12. Sensor Section	123	15.3.5. Cleaning of Transfer Roller	196
12.2.13. Motor Section	126	15.3.6. Fixing	197
12.2.14. LSU Section	129	15.4. Terminal Guide of The ICs Transistors and Diodes	198
12.2.15. CIS Control Section	130	15.4.1. Main Board	198
12.2.16. High Voltage Value Check Point	132	15.4.2. Operation Board	198
12.2.17. High Voltage Section	134	15.4.3. High Voltage Power Supply Board	199
12.2.18. USB Section	139	15.4.4. Low Voltage Power Supply Board	199
12.2.19. LAN SECTION	143	15.5. How to Replace the Flat Package IC	200
12.2.20. Main Board Section	148	15.5.1. Preparation	200
12.2.21. Power Supply Board Section	151	15.5.2. Flat Package IC Removal Procedure	200
12.3. DOCUMENT JAMS (AUTO DOCUMENT FEEDER) (KX-MB2010 ONLY)	154	15.5.3. Flat Package IC Installation Procedure	201
12.4. RECORDING PAPER JAM	156	15.5.4. Bridge Modification Procedure	201
12.4.1. When the recording paper has jammed inside of the unit	157	15.6. Main Board Section	202
12.4.2. When the recording paper is not fed into the unit properly	163	15.6.1. NG Example	203
12.4.3. When the recording paper in the manual input tray is not fed into the unit properly	164	15.7. Test Chart	204
13 Service Fixture & Tools	165	15.7.1. ITU-T No.1 Test Chart	204
14 Disassembly and Assembly Instructions	166	15.7.2. ITU-T No.2 Test Chart	205
14.1. Bottom Section	167	16 Schematic Diagram	207
14.2. Left Side Section	167	16.1. For Schematic Diagram	207
14.3. Operation Panel Section	168	16.2. Main Board (KX-MB2000)	208
14.4. Open Top Cover	168	16.2.1. Main Board (1)	208
14.5. Remove Operation Panel	169	16.2.2. Main Board (2)	212
14.6. Remove Operation Board	169	16.2.3. Main Board (3)	214
14.7. Remove Main Board	170	16.3. Main Board (KX-MB2010)	216
14.8. Remove Gear Chassis Section	171	16.3.1. Main Board (1)	216
14.9. Remove Right Cover	172	16.3.2. Main Board (2)	220
14.10. Remove Right Cassette Guide	172	16.3.3. Main Board (3)	222
14.11. Remove Bottom Plate	173	16.4. Operation Board	224
14.12. Remove Laser Unit	173	16.5. Sensor Board	225
14.13. Remove Pick up Roller	174	16.6. High Voltage Power Supply Board	226
14.14. Remove Low Voltage Power Board	175	16.7. Low Voltage Power Supply Board	227
14.15. Remove Mirror	175	17 Printed Circuit Board	229
14.16. Remove High Voltage Power Board	176	17.1. Main Board	229
14.17. Installation Position of The Lead	177	17.1.1. Main Board: Component View	229
14.17.1. Top Cover Section (1)	177	17.1.2. Main Board: Bottom View	230
14.17.2. Top Cover Section (2)	178	17.2. Operation Board	231
14.17.3. Top Cover Section (3)	179	17.2.1. Operation Board	231
14.17.4. Bottom Part Section (1)	180	17.3. Sensor Board	232
14.17.5. Bottom Part Section (2)	181	17.3.1. Toner Sensor Board	232
14.17.6. Side Cabinet Section (1)	182	17.3.2. Fuser Board	232
14.17.7. Side Cabinet Section (2)	183	17.3.3. Pickup Sensor Board	232
14.17.8. Side Cabinet Section (3)	184	17.3.4. Registration Sensor Board	233
14.17.9. Side Cabinet Section (4)	185	17.3.5. Varistor Sensor Board	233
14.17.10. AC Inlet Section	185	17.3.6. Flatbed Relay Board	233
15 Maintenance	186	17.3.7. ADF Sensor Board (KX-MB2010 ONLY)	234
		17.3.8. CIS Home Sensor Board	234
		17.4. High Voltage Power Supply Board	235

17.4.1. HIGH VOLTAGE POWER SUPPLY BOARD: COMPONENT VIEW-----	235
17.4.2. HIGH VOLTAGE POWER SUPPLY BOARD: BOTTOM VIEW -----	235
17.5. Low Voltage Power Supply Board -----	236
17.5.1. LOW VOLTAGE POWER SUPPLY BOARD: COMPONENT VIEW-----	236
17.5.2. LOW VOLTAGE POWER SUPPLY BOARD: BOTTOM VIEW -----	236
18 Exploded View and Replacement Parts List -----	237
18.1. Cabinet, Mechanical and Electrical Parts Location-----	237
18.1.1. Operation Panel Section-----	237
18.1.2. ADF Section (KX-MB2010) -----	238
18.1.3. Flatbed Section (KX-MB2000) -----	239
18.1.4. ADF Gear Section (KX-MB2010)-----	240
18.1.5. Top Cover Section -----	241
18.1.6. Main Cabinet Section-----	242
18.1.7. Fuser Section-----	243
18.1.8. Bottom Cabinet Section (1)-----	244
18.1.9. Separation (DFP) Roller Section -----	245
18.1.10. Side Cabinet Section -----	246
18.1.11. Motor Section-----	247
18.1.12. Bottom Cabinet Section (2)-----	248
18.1.13. Output Tray Section-----	249
18.1.14. Actual Size of Screws and Washer -----	250
18.1.15. Accessories and Packing Materials (KX- MB2010)-----	251
18.1.16. Accessories and Packing Materials (KX- MB2000)-----	252
18.2. Replacement Parts List-----	253
18.2.1. Cabinet and Electrical Parts -----	253
18.2.2. Main Board (KX-MB2000)-----	256
18.2.3. Main Board (KX-MB2010) -----	260
18.2.4. Operation Board -----	264
18.2.5. Sensor Board Parts -----	265
18.2.6. High Voltage Power Board-----	266
18.2.7. Low Voltage Power Board-----	266

1 Safety Precautions

1. Before servicing, unplug the AC power cord to prevent an electric shock.
2. When replacing parts, use only the manufacturer's recommended components.
3. Check the condition of the power cord. Replace if wear or damage is evident.
4. After servicing, be sure to restore the lead dress, insulation barriers, insulation papers, shields, etc.
5. Before returning the serviced equipment to the customer, be sure to perform the following insulation resistance test to prevent the customer from being exposed to shock hazards.

1.1. For Service Technicians

- **Repair service shall be provided in accordance with repair technology information such as service manual so as to prevent fires, injury or electric shock, which can be caused by improper repair work.**

1. When repair services are provided, neither the products nor their parts or members shall be remodeled.
2. If a lead wire assembly is supplied as a repair part, the lead wire assembly shall be replaced.
3. FASTON terminals shall be plugged straight in and unplugged straight out.

- **ICs and LSIs are vulnerable to static electricity.**

When repairing, the following precautions will help prevent recurring malfunctions.

1. Cover the plastic part's boxes with aluminum foil.
2. Ground the soldering irons.
3. Use a conductive mat on the worktable.
4. Do not touch the IC or LSI pins with bare fingers.

1.2. AC Caution

For safety, before closing the lower cabinet, please make sure of the following precautions.

1. The earth lead is fixed with the screw.
2. The AC connector is connected properly.

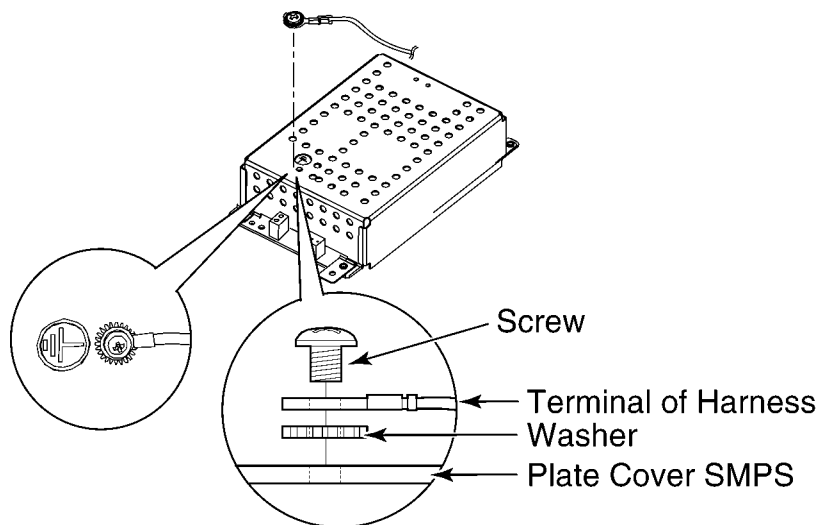

1.3. Personal Safety Precautions

1.3.1. Moving Sections of the Unit

Be careful not to let your hair, clothes, fingers, accessories, etc., become caught in any moving sections of the unit. The moving sections of the unit are the rollers and a gear. There is a separation roller and a document feed roller which are rotated by the document feed motor. A gear rotates the two rollers. Be careful not to touch them with your hands, especially when the unit is operating.

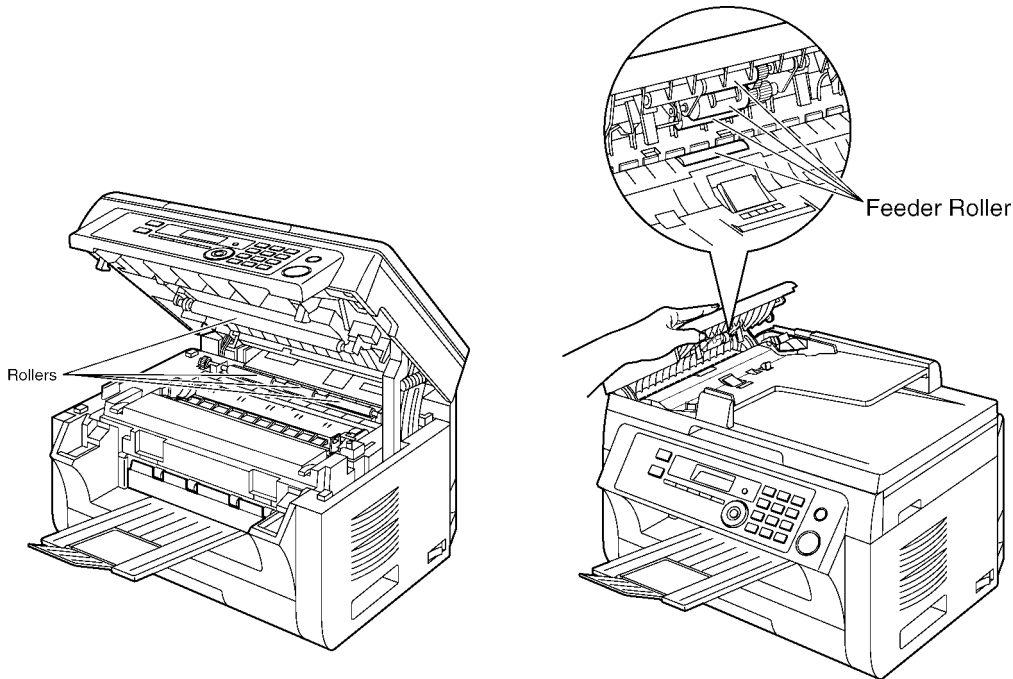

1.3.2. Live Electrical Sections

All the electrical sections of the unit supplied with AC power by the AC power cord are live. Never disassemble the unit for service with the AC power supply plugged in.

CAUTION:

AC voltage is supplied to the primary side of the power supply unit. Therefore, always unplug the AC power cord before disassembling for service.

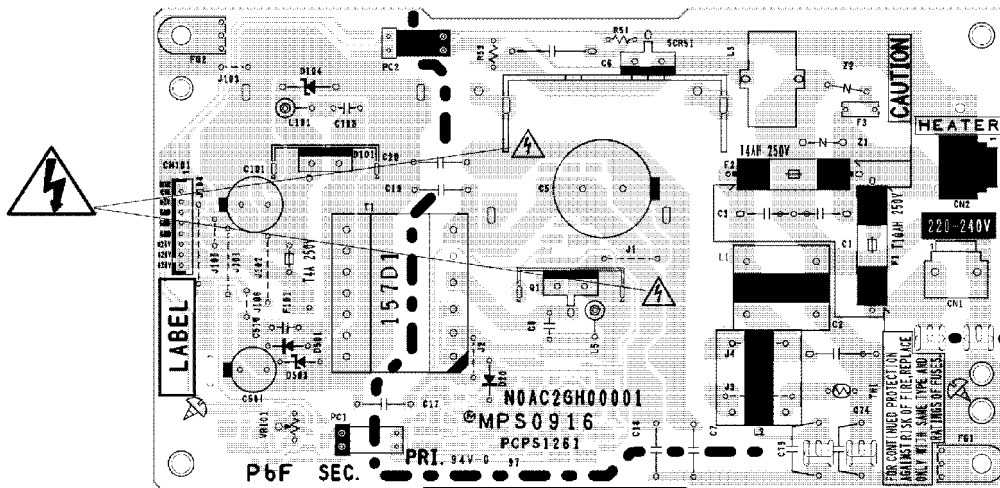

1.4. Service Precautions

1.4.1. Precautions to Prevent Damage from Static Electricity

Electrical charges accumulate on a person. For instance, clothes rubbing together can damage electric elements or change their electrical characteristics. In order to prevent static electricity, touch a metallic part that is grounded to release the static electricity. Never touch the electrical sections such as the power supply unit, etc.

2 Warning

2.1. About Lead Free Solder (PbF: Pb free)

Note:

In the information below, Pb, the symbol for lead in the periodic table of elements, will refer to standard solder or solder that contains lead.

We will use PbF solder when discussing the lead free solder used in our manufacturing process which is made from Tin, (Sn), Silver, (Ag), and Copper, (Cu).

This model, and others like it, manufactured using lead free solder will have PbF stamped on the PCB. For service and repair work we suggest using the same type of solder although, with some precautions, standard Pb solder can also be used.

Caution

- PbF solder has a melting point that is 50° ~ 70° F, (30° ~ 40°C) higher than Pb solder. Please use a soldering iron with temperature control and adjust it to 700° ± 20° F, (370° ± 10°C). In case of using high temperature soldering iron, please be careful not to heat too long.
- PbF solder will tend to splash if it is heated much higher than its melting point, approximately 1100°F, (600°C).
- If you must use Pb solder on a PCB manufactured using PbF solder, remove as much of the original PbF solder as possible and be sure that any remaining is melted prior to applying the Pb solder.
- When applying PbF solder to double layered boards, please check the component side for excess which may flow onto the opposite side (See figure, below).

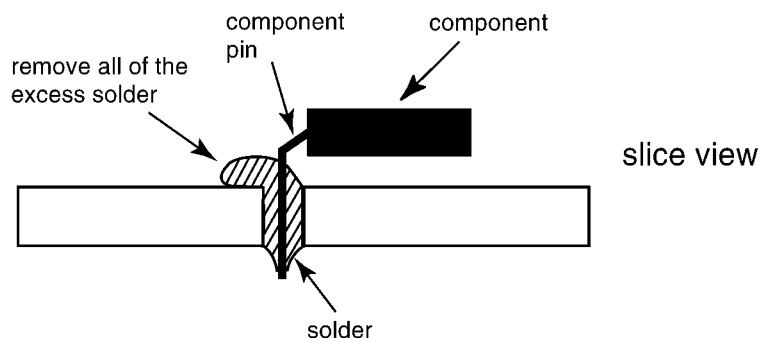

2.1.1. Suggested PbF Solder

There are several types of PbF solder available commercially. While this product is manufactured using Tin, Silver, and Copper, (Sn+Ag+Cu), you can also use Tin and Copper, (Sn+Cu), or Tin, Zinc, and Bismuth, (Sn+Zn+Bi). Please check the manufacturer's specific instructions for the melting points of their products and any precautions for using their product with other materials.

The following lead free (PbF) solder wire sizes are recommended for service of this product: 0.3mm, 0.6mm and 1.0mm.

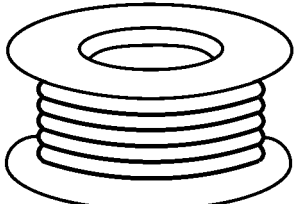
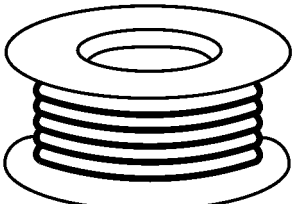
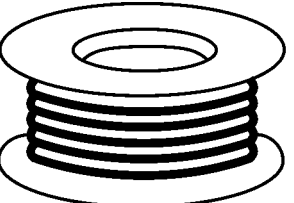
0.3mm X 100g	0.6mm X 100g	1.0mm X 100g
		

2.2. Discarding of P. C. Board

When discarding P. C. Board, delete all personal information such as telephone directory and caller list or scrap P. C. Board.

2.3. Insulation Resistance Test

1. Unplug the power cord and short the two prongs of the plug with a jumper wire.
2. Turn on the power switch.
3. Measure the resistance value with an ohmmeter between the jumpered AC plug and each exposed metal cabinet part (screw heads, control shafts, bottom frame, etc.).

Note: Some exposed parts may be isolated from the chassis by design. These will read infinity.

4. If the measurement is outside the specified limits, there is a possibility of a shock hazard.

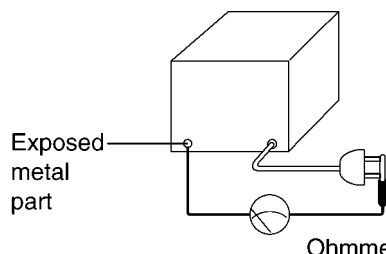

Resistance = more than $10M\Omega$ (at DC 500 V)

2.4. Battery Caution

CAUTION

Danger of explosion if the battery is incorrectly replaced. Replace only with the same or equivalent type recommended by the manufacturer. Dispose of used batteries according to the manufacturer's instructions.

The lithium battery is a critical component (type No.CR2354). Please observe for the proper polarity and exact location when replacing it and the soldering the replacement lithium battery in.

2.4.1. Information for Users on Collection and Disposal of Old Equipment and used Batteries



These symbols on the products, packaging, and/or accompanying documents mean that used electrical and electronic products and batteries should not be mixed with general household waste.

For proper treatment, recovery and recycling of old products and used batteries, please take them to applicable collection points, in accordance with your national legislation and the Directives 2002/96/EC and 2006/66/EC.

By disposing of these products and batteries correctly, you will help to save valuable resources and prevent any potential negative effects on human health and the environment which could otherwise arise from inappropriate waste handling.

For more information about collection and recycling of old products and batteries, please contact your local municipality, your waste disposal service or the point of sale where you purchased the items.

Penalties may be applicable for incorrect disposal of this waste, in accordance with national legislation.



For business users in the European Union

If you wish to discard electrical and electronic equipment, please contact your dealer or supplier for further information.

[Information on Disposal in other Countries outside the European Union]

These symbols are only valid in the European Union. If you wish to discard these items, please contact your local authorities or dealer and ask for the correct method of disposal

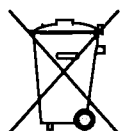

Cd

Note for the battery symbol (bottom two symbol examples):

This symbol might be used in combination with a chemical symbol. In this case it complies with the requirement set by the Directive for the chemical involved.

2.5. Laser Beam And Fuser Unit Section

- The printer of this unit utilizes a laser. Use of controls or adjustments or performance of procedures other than those specified herein may result in hazardous radiation exposure.
- The fuser unit is inside of the unit and gets hot. Do not touch it when removing the jammed paper or cleaning the lower glass.

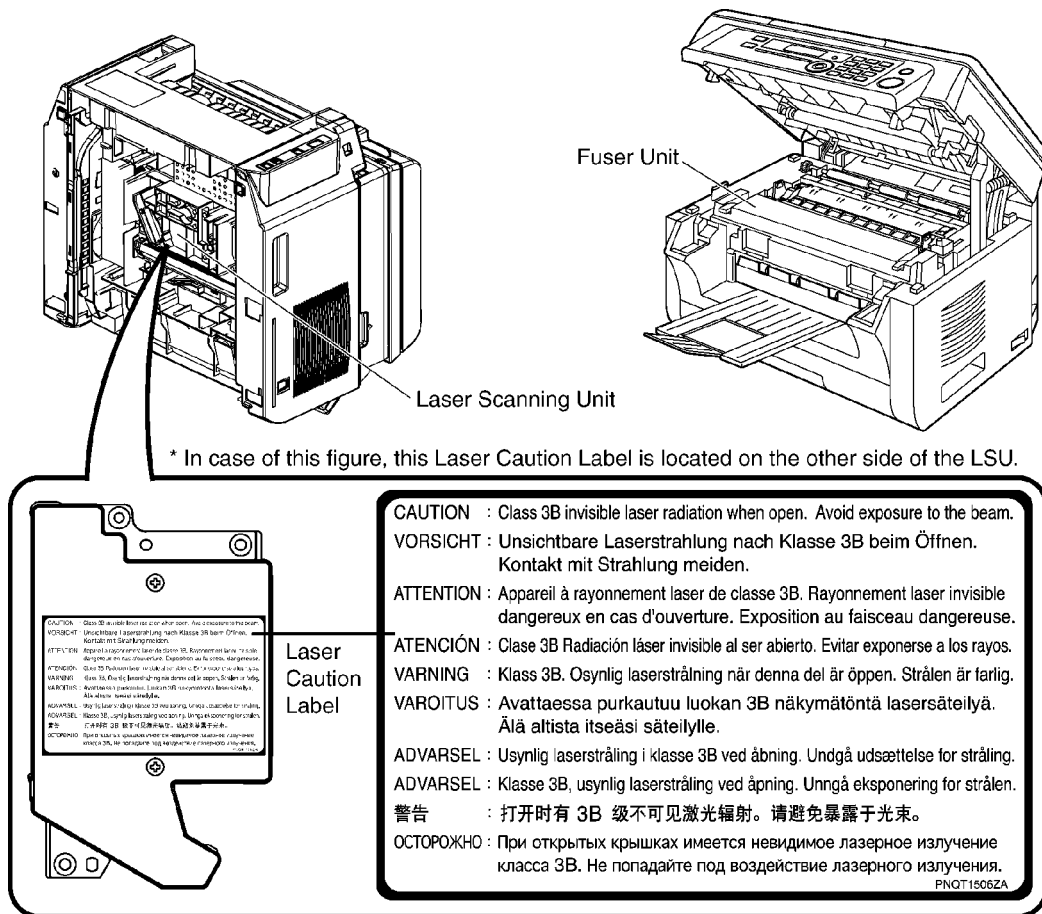

2.6. Note for Repairing

Caution

Please inform users of the danger of data being lost at the time of repair.

Data will be lost in the following situations.

1. When replacing the ROM ass'y.
2. When replacing the Main board ass'y.
3. When executing mode #550 or #710.

There is a possibility of data loss in the following situations.

1. When removing a board.
2. When writing new software to ROM.

3 Specifications

Document Size:	Max. 216 mm in width, Max. 600 mm in length
Effective Scanning Width:	208 mm
Effective Printing Width:	Letter/ Legal: 208 mm A4: 202 mm
Transmission Time*¹:	Approx. 4 s/page (ECM-MMR Memory transmission)* ²
Scanning Density:	Scanning resolution: Up to 600 × 1,200 dpi (Optical) Up to 9,600 × 9,600 dpi (Interpolated) Copy resolution: Up to 600 × 600 dpi 64-level
Photo resolution:	Colour Contact Image Sensor
Scanner Type:	Laser printer
Printer Type:	Operating Environment: 10°C—32.5°C, 20—70% RH (Relative Humidity) Dimensions: KX-MB2000: Approx. width 420 mm x depth 432 mm x height 255 mm KX-MB2010: Approx. width 420 mm x depth 432 mm x height 305 mm Mass (Weight): KX-MB2000: Approx. 11 kg KX-MB2010: Approx. 12 kg Standby: Approx. 5.5 W Preheat: Approx. 65 W Copy: Approx. 500 W Maximum: Approx. 1,000 W (When the fuser lamp turns on) 220-240 V AC, 50/60 Hz
Power Consumption:	
Power Supply:	
Memory Capacity (for operation and storing memory):	32 MB
Scan to email address memory capacity:	5 MB in total (including the header and email message)
Scan to FTP server memory capacity:	5 MB in total
Scan to SMB folder memory capacity:	5 MB in total
Laser diode properties:	Laser output: Max. 15 mW Wavelength: 760 nm—800 nm Emission duration: Continuous
Print Speed:	Approx. 24 ppm (pages per minute)
Printing Resolution:	600 x 600 dpi
LED light of CIS properties:	LED radiation output: Max. 1 mW Wavelength: Red 630 nm typ. Green 520 nm typ. Blue 465 nm typ. Emission duration: Continuous
Product life:	2 hundreds-thousands (except drum unit, toner cartridge)

*¹ Transmission speed depends on the contents of the pages, resolution, telephone line conditions and capability of the other party's machine.

*² Transmission speed is based upon the ITU-T No. 1 Test Chart. (Refer to **ITU-T No.1 Test Chart** (P.204).) If the capability of the other party's machine is inferior to your unit, the transmission time may be longer.

Note:

- Design and specifications are subject to change without notice.
- The pictures and illustrations in these instructions may vary slightly from the actual product.
- The accuracy of the clock is approximately ±60 seconds a month.

4 General/Introduction

4.1. Optional Accessories

Model No.	Description	Specifications
KX-FAT411E	Replacement toner cartridge*1	1 toner cartridge
KX-FAD412E	Replacement drum cartridge	1 drum cartridge

*1 Prints about 2,000 pages at ISO/IEC 19752 standard page.

Note:

- ISO/IEC 19752 standard is as follows:
 - Environment: 23 ± 2°C / 50 ± 10% RH
 - Print mode: Continuous printing

4.2. Translation Lists

4.2.1. Error Message (Display)

ENGLISH	CZECH	HUNGARIAN	SLOVAK
CALL SERVICE 1	VOLEJTE SERVIS1	Hív: 1.szerviz	VOLAJTE SERVIS1
CALL SERVICE 2	VOLEJTE SERVIS2	Hív: 2.szerviz	VOLAJTE SERVIS2
CALL SERVICE 3	VOLEJTE SERVIS3	Hív: 3.szerviz	VOLAJTE SERVIS3
CALL SERVICE 4	VOLEJTE SERVIS4	Hív: 4.szerviz	VOLAJTE SERVIS4
CALL SERVICE 5	VOLEJTE SERVIS5	Hív: 5.szerviz	VOLAJTE SERVIS5
CALL SERVICE 6	VOLEJTE SERVIS6	Hív: 6.szerviz	VOLAJTE SERVIS6
CHANGE DRUM	VYMEN.FOTOVÁLEC	Cseréljen dob	VYMENTE VALEC
CHECK DOCUMENT	CHYBÍ DOKUMENT	Hiba az iratnál	VLOZTE DOKUMENT
CHECK DRUM	ZKONT.FOTOVÁLEC	Dob ellenőrzés	SKONTROL.VALEC
CHECK PAPER #1	ZKONT.PAPÍR #1	Papírhiba #1	SKONTR.PAPIER#1
CHECK PAPER TRAY #1	ZKONTROL.PAPÍR ZÁSOB #1	Papír hiba Tálca #1	SKONTR.PAPIER ZASOB 1
CHECK PICK UP INPUT TRAY #2	ZKONT.PODÁVÁNÍ VSTUP ZÁSOB #2	Papír ellenőrzés Papírtálca #2	SKONTR.PODAVANIE ZASOBNÍK C.2
CHECK REAR COVER	ZKONT.ZADNÍ KRYT	Hátsó fedél hiba	SKONTR.ZAD.KRYT
COOL DOWN FUSER	NÍZKÁ TEPL. PECE	Fixáló lehűtése	CHLADENIE
DRUM LIFE LOW REPLACE SOON	ZIV.VÁLCE KONCÍ VYMENTE BRZY	Élettartam kevés Hamarosan csere	VALEC DOSLUHUJE COSKORO VYMENTE
EMAIL SIZE OVER	E-MAIL JE VELKY	E-mail túlméret.	SCHRÁNKA JE PLNÁ
FILE SIZE OVER	MOC VELKY SOUBOR	Túl nagy fájl	VELKY SUBOR < 20MB
KEEP COPYING	KOPIRUJE SE	Másolás folyik	DALSIE KOPIROV.
LOW TEMP.	NÍZKÁ TEPLOTA	Alacsony hőmérs.	NIZKA TEPLOTA
MEMORY FULL	PAMET ZAPLNENA	Memória megtelt	PLNÁ PAMĀT
MODEM ERROR	CHYBA MODEMU	Modem hiba	PORUCHA MODEMU
OUT OF PAPER INPUT TRAY #2	DOSEL PAPIR VSTUP ZÁSOB #2	Papír kifogyott Papírtálca #2	MINUL SA PAPIER ZASOBNÍK C.2
PAPER IN TRAY #2	PAPÍR V ZÁSOB #2	PapírtálcaHiba#2	PAPIER V ZAS.C.2
PAPER JAMMED	ZMACKANY PAPIR	Papír elakadt	UVIAZOL PAPIER
OPEN TOP COVER	OTEVR.HOR.KRYT	Nyissa:felsőfed	OTVORTE HOR.KRYT
PC FAIL OR BUSY	PC CHYBA/OBSAZ.	PC hiba/foglalt	CHYBA PC
PLEASE WAIT	CEKEJTE	Kérem, várjon	CAKAJTE,PROŠÍM
REMOVE DOCUMENT	VYJMI DOKUMENT	Iratot vegye ki	VYBERTE DOKUM.
REPLACE DRUM CHANGE SUPPLIES	VYMENTE VALEC VYMEN.SPOT.MAT.	Cseréljen dob Fogyóeszk.csere	VYMENTE VALEC VYMEN SPOTR.MAT
SCANNER POSITION ERROR	POZICE SKENERU CHYBA	Szkenner pozíció Hiba	POZICIA SKENERA CHYBA
TONER EMPTY	DOSEL TONER	Nincs festék	MINUTY TONER
CHANGE SUPPLIES	VYMEN.SPOT.MAT.	Fogyóeszk.csere	VYMEN SPOTR.MAT
TONER LOW	MÁLO TONERU	Festék fogyóban	MALO TONERA
TOP COVER OPEN	HOR.KRYT OTEVREN	FelsőFedélNyitva	H.KRYT OTVORENY

5 Features

5.1. General Features

General

- LCD (Liquid Crystal Display) readout

Multi-Function Printer

Output tray (approx. 100 sheets)

Letter/A4/Legal

Automatic document feeder (20 sheets) (KX-MB2010 ONLY)

Resolution: Standard/Fine/Super fine/Photo (64 level).

STANDARD: For printed or typewritten originals with normal-sized characters.

FINE: For originals with small printing.

SUPER FINE: For originals with very small printing.

PHOTO: For originals containing photographs, shaded drawing, etc.

- 250-sheet paper capacity (60 g/m² ~ 75 g/m²)

Approx. 150 pages of memory transmission

Approx. 110 pages of memory reception

Enhanced Copier Function

Multi-copy function (up to 99 copies)

Enlargement and reduction

64-Level halftone

5.2. Hardware Requirements for Multi-Function Software

To use Multi-Function Station on your computer, the following are required:

Operating System:

Windows 2000 / Windows XP / Windows Vista

CPU:

Windows 2000: Pentium® II or higher processor

Windows XP: Pentium III or higher processor

Windows Vista: Pentium 4 or higher processor

RAM:

Windows 2000/Windows XP: 128 MB (256 MB or more recommended)

Windows Vista: 512 MB (1,024 MB or more recommended)

Other Hardware:

CD-ROM drive

Hard disk drive with at least 200 MB of available space

USB interface

LAN interface (10Base-T/100Base-TX)

Other:

Internet Explorer® 5.0 or later

Warning:

- To assure continued emission limit compliance;
 - use only shielded USB cable (Example: Hi-Speed USB 2.0 certified cable).
 - use only shielded LAN cable (category 5 straight cable).
- To protect the unit, use only shielded USB cable in areas where thunderstorms occur.
- To use Easy Print Utility on your computer, the following are required:
 - Windows 2000 Service Pack 4 and Security update for Windows 2000 (KB835732). Install KB835732 from Microsoft download site before installing Easy Print Utility
 - Windows XP Service Pack 2 or later.

Note:

- A USB cable is not supplied. Please purchase a shielded Type-A male/Type-B male USB cable.

6 Technical Descriptions

6.1. Connection Diagram

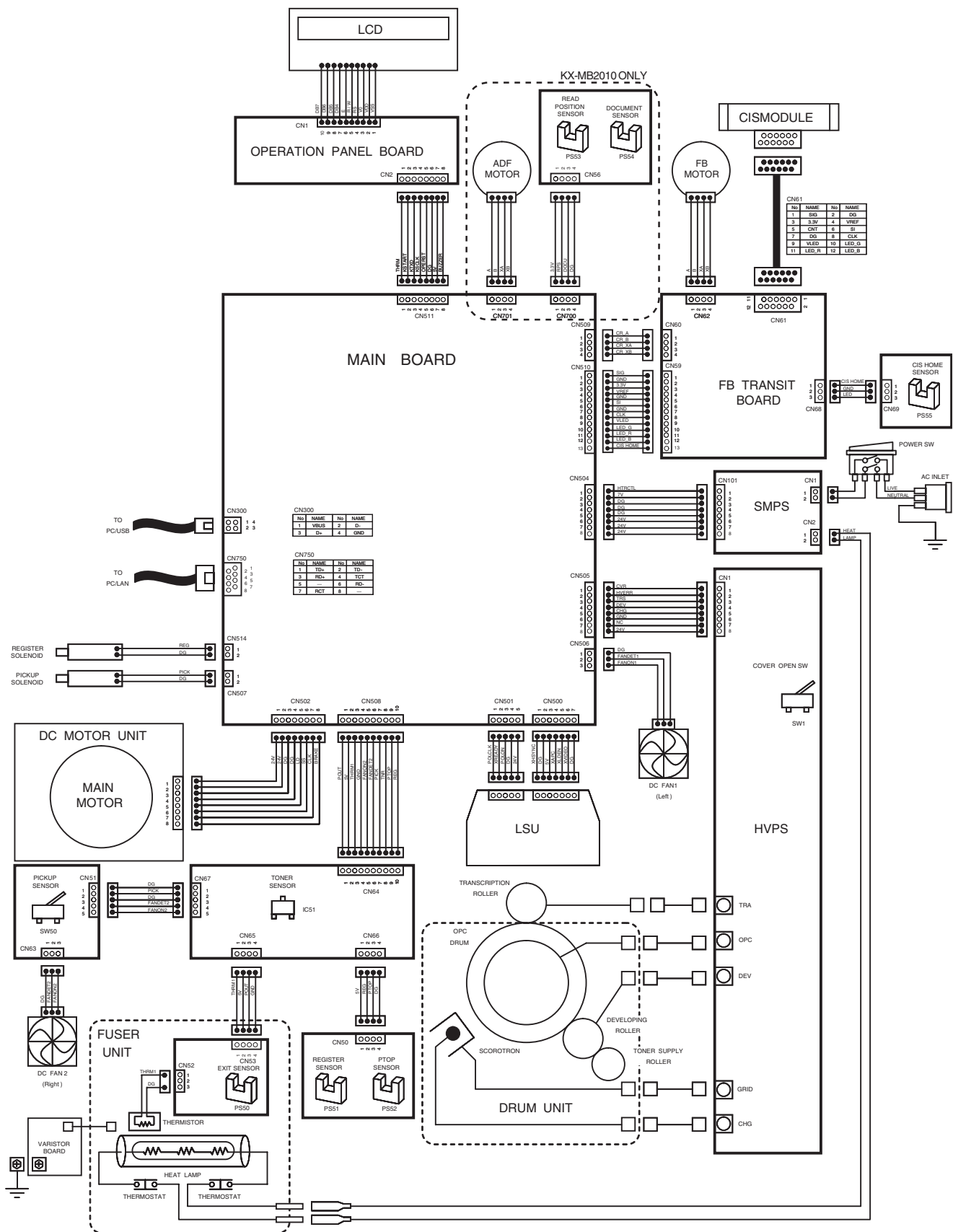

6.2. General Block Diagram

MAIN UNIT

SOC (IC300)

This custom IC is used for general MFP operations.

- | | | |
|-----|-------------------------|--|
| 1) | CPU | ARM9 operating at 250MHz. |
| 2) | SDRAM Controller | Controls SDRAM Memory. |
| 3) | USB Controller with PHY | Apply to USB2.0 HS |
| 4) | Scanner I/F | Controls the CIS and AFE, and process the scan images. |
| 5) | LSU I/F | Controls the polygon motor and outputs the VIDEO signal to LSU. |
| 6) | MOTOR I/F | Controls the DC motor and Stepping Motor. |
| 7) | FAN I/F | Controls FAN MOTOR and detect the rotation of FAN MOTOR. |
| 8) | OPERATION PANEL I/F | Serial interface with Operation Panel. |
| 9) | SENSOR I/F | Detects the sensor signal. |
| 10) | I/O PORT | I/O Port Interface. |
| 11) | A/D, D/A converter | Sends beep tones, etc.
Convert the analog signal to the digital signal. |
| 12) | RTC | Real time clock. |
| 13) | LAN Controller | Ethernet Control. |

ROM (IC402)

This 8MB FLASH ROM contains all of the program instructions on the unit operations.

SYNCHRONOUS DYNAMIC RAM (IC400)

This 256Mbit SDRAM is used for CPU work and receiving memory and page memory.

POWER SUPPLY

DC-DC converters generate 3.3V and 1.2V for system power.

Regulator generates 5V for peripheral devices.

READ SECTION

CIS Unit to read transmitted documents.

CIS Unit is connected to FLATBED transit Unit.

Scan data is converted by AFE(IC503).

MOTOR

This model has 1 DC motor and 2 stepping motors.

IC300 drives the DC motor for printing.

IC502 and IC700 drive the stepping motor for Auto Document Feeder motor and CIS carriage.

LSU

Forms the images on the OPC DRUM by rotating polygon motor and reflecting the laser beam against polygon.

SENSORS

Composed of 2 switches and 6 sensors.

POWER SUPPLY BOARD

Supplies +24V and +7V to the Main unit and controls the Heat Lamp.

HIGH VOLTAGE POWER SUPPLY BOARD

Supplies bias need for the printing operation: bias of the DRUM, Developing and Transcription.

FIXING UNIT

Composed heat lamp, thermistor and thermostats.

MB2000 series System Schematic

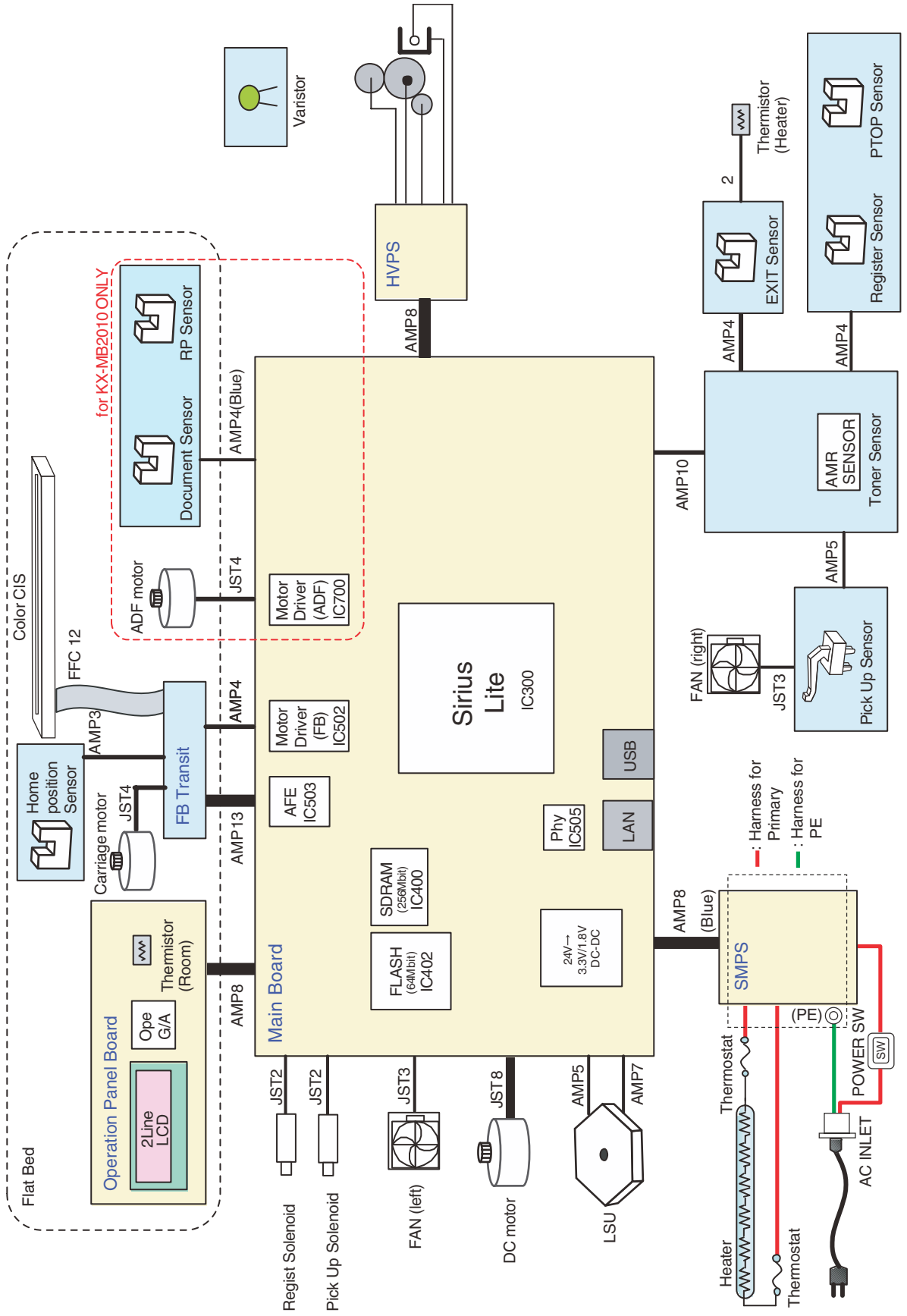

6.3. Main Board Section

6.3.1. Data Flow

[PC Scan]

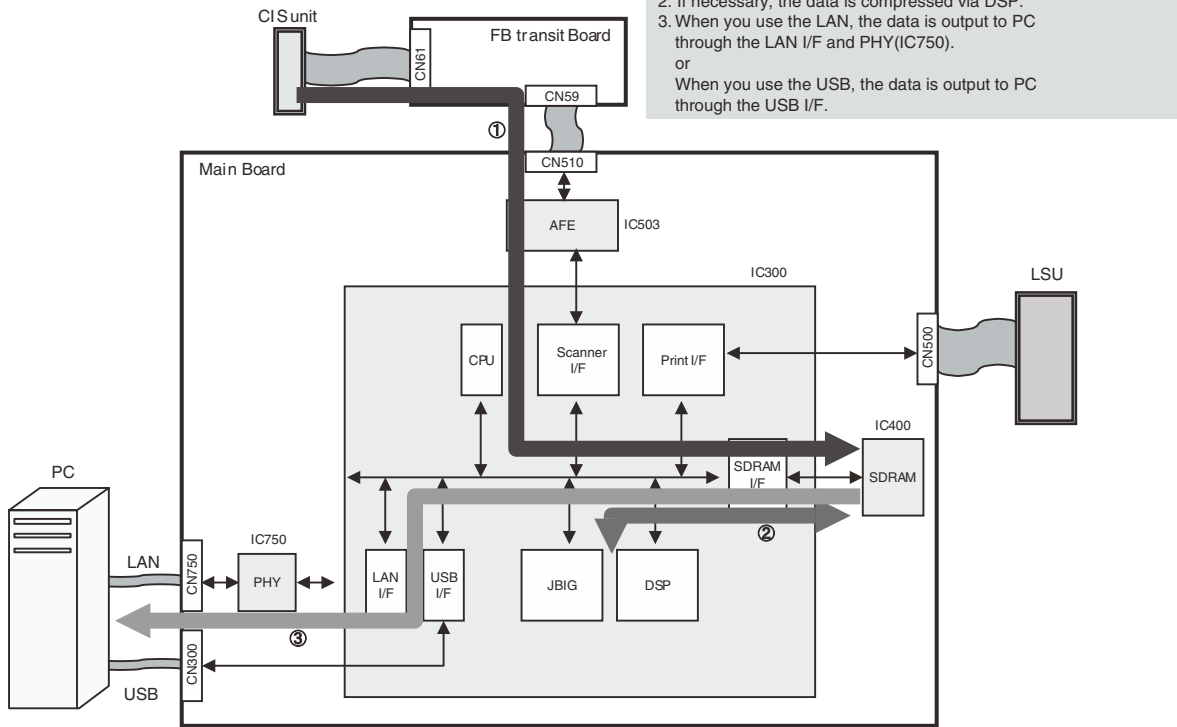

[PC print]

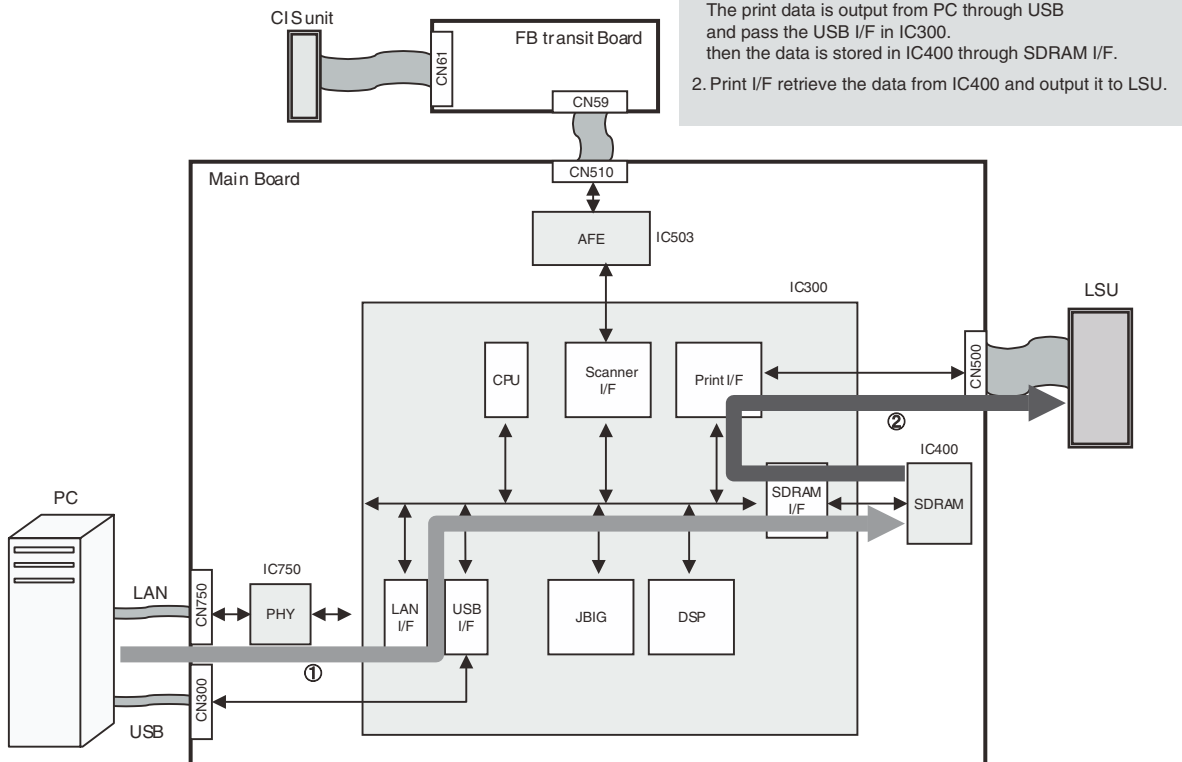

[Copy]

1. An analog image data is output from CISunit to IC503. IC503 decode the analog data to digital data, and output to IC300. Scanner I/F in IC300 process image data and store it in IC400 through SDRAM I/F.
2. If necessary, the data is compressed via JBIG.
3. Print I/F retrieve the data from IC400 and output it to LSU.

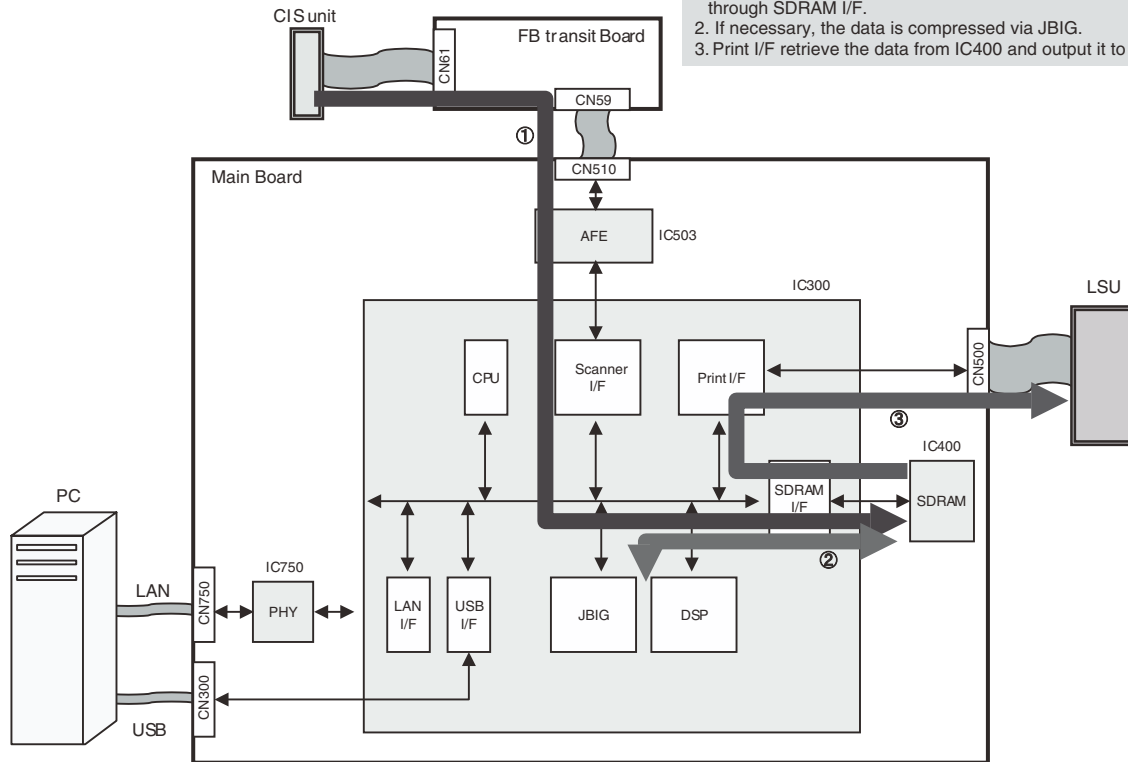

Description of Pin Distribution (IC300) SOC (System On Chip)

PIN NO.	PinName	I/O	POWER SUPPLY VOLTAGE	EXPLANATION
A02	LEDONB	O	3.3V	SCANNER INTERFACE
A03	NCCDON	O	3.3V	SCANNER INTERFACE
A04	AFEMCLK	O	3.3V	SCANNER INTERFACE
A05	NCCDCP	O	3.3V	NOT USED
A06	CCDCLK	O	3.3V	NOT USED
A07	PIO29	O	3.3V	OPERATION PANEL INTERFACE
A08	PIO57	O	3.3V	CARRIAGE MOTOR INTERFACE
A09	PIO53	O	3.3V	CARRIAGE/ADF MOTOR INTERFACE
A10	PIO50	O	3.3V	CARRIAGE/ADF MOTOR INTERFACE
A11	PIO46	O	3.3V	FAN1 CONTROL
A12	PIO42	O	3.3V	DC MOTOR INTERFACE
A13	NFRCE	O	3.3V	FLASH MEMORY CHIP SELECT
A14	FRMD0	I/O	3.3V	FLASH MEMORY DATA BUS 0
A15	FRMD3	I/O	3.3V	FLASH MEMORY DATA BUS 3
A16	FRMD7	I/O	3.3V	FLASH MEMORY DATA BUS 7
A17	FRMA3	O	3.3V	FLASH MEMORY ADDRESS BUS 3
A18	FRMA6	O	3.3V	FLASH MEMORY ADDRESS BUS 6
A19	FRMA10	O	3.3V	FLASH MEMORY ADDRESS BUS 10
A20	THRMAVDD	-	3.3V	POWER SUPPLY
A21	FRMA11	O	3.3V	FLASH MEMORY ADDRESS BUS 11
A22	FRMA15	O	3.3V	FLASH MEMORY ADDRESS BUS 15
A23	FRMA17	O	3.3V	FLASH MEMORY ADDRESS BUS 17
A24	FRMA20	O	3.3V	FLASH MEMORY ADDRESS BUS 20
A25	FRMA22	O	3.3V	FLASH MEMORY ADDRESS BUS 22
AA01	SDMD8	I/O	3.3V	SDRAM DATA BUS 8
AA02	SDMD9	I/O	3.3V	SDRAM DATA BUS 9
AA03	SDMA7	O	3.3V	SDRAM ADDRESS BUS 7
AA04	SDMA6	O	3.3V	SDRAM ADDRESS BUS 6
AA23	VDD1.2	-	1.2V	POWER SUPPLY
AA24	AFERST	O	3.3V	NCU INTERFACE
AA25	RING	I	3.3V	NCU INTERFACE
AA26	EXTINT	I	3.3V	NCU INTERFACE
AB01	SDMD10	I/O	3.3V	SDRAM DATA BUS 10
AB02	SDMD11	I/O	3.3V	SDRAM DATA BUS 11
AB03	SDMA5	O	3.3V	SDRAM ADDRESS BUS 5
AB04	VDD1.2	-	1.2V	POWER SUPPLY
AB23	VSS	-	GND	GND
AB24	BTXD	O	3.3V	NCU INTERFACE
AB25	BRXD	I	3.3V	NCU INTERFACE
AB26	AFECLK	O	3.3V	NCU INTERFACE
AC01	SDMD12	I/O	3.3V	SDRAM DATA BUS 12
AC02	SDMD13	I/O	3.3V	SDRAM DATA BUS 13
AC03	SDMA4	O	3.3V	SDRAM ADDRESS BUS 4
AC04	VSS	-	GND	GND
AC05	VSS	-	GND	GND
AC06	VDD1.2	-	1.2V	POWER SUPPLY
AC07	TXD0	O	3.3V	ETHERNET INTERFACE
AC08	TX_ER	O	3.3V	ETHERNET INTERFACE
AC09	RXD1	I	3.3V	ETHERNET INTERFACE
AC10	VDD3.3	-	3.3V	POWER SUPPLY
AC11	TEST	I	3.3V	NOT USED
AC12	USBREXT	I	3.3V	USB INTERFACE
AC13	VDD1.2	-	1.2V	POWER SUPPLY
AC14	VDD3.3	-	3.3V	POWER SUPPLY
AC15	USBXIN	I	3.3V	CRYSTAL(12MHz) INPUT
AC16	LSI_SCAN_ENABLE	I	3.3V	NOT USED
AC17	VDD1.2	-	1.2V	POWER SUPPLY
AC18	NWDTRST	O	3.3V	WATCH DOG TIMER RESET OUTPUT
AC19	LSI_TN	I	3.3V	NOT USED
AC20	PSCIO2	I	3.3V	INPUT PORT (FANDET1)
AC21	PSCIO6	O	3.3V	NOT USED
AC22	VDD1.2	-	1.2V	POWER SUPPLY
AC23	VSS	-	GND	GND
AC24	ATXD	O	3.3V	NCU INTERFACE
AC25	BBITCLK	I/O	3.3V	NCU INTERFACE

PIN NO.	PinName	I/O	POWER SUPPLY VOLTAGE	EXPLANATION
AC26	BSPCLK	I/O	3.3V	NCU INTERFACE
AD01	SDMD14	I/O	3.3V	SDRAM DATA BUS 14
AD02	SDMD15	I/O	3.3V	SDRAM DATA BUS 15
AD03	VSS	-	GND	GND
AD04	NBATRST	I	3.3V	BATTERY RESET INPUT
AD05	VDD2RTC	-	1.2V	POWER SUPPLY
AD06	CRS	I	3.3V	ETHERNET INTERFACE
AD07	TXD1	O	3.3V	ETHERNET INTERFACE
AD08	RX_DV	I	3.3V	ETHERNET INTERFACE
AD09	RXD2	I	3.3V	ETHERNET INTERFACE
AD10	RX_ER	I	3.3V	ETHERNET INTERFACE
AD11	CLKSEL	I	3.3V	NOT USED
AD12	USBVSSA33_BIAS	-	GND	GND
AD13	USBVSSA33	-	GND	GND
AD14	USBVDDA12_SQ	-	1.2V	POWER SUPPLY
AD15	USBVSSA12	-	GND	GND
AD16	LSI_TRSTN	I	3.3V	NOT USED
AD17	LSI_TDO	O	3.3V	NOT USED
AD18	NRST	I	3.3V	SYSTEM RESET INPUT
AD19	HTRCTL	O	3.3V	HEATER CONTROL
AD20	PSCIO3	I	3.3V	INPUT PORT (POUT)
AD21	PSCIO7	O	3.3V	NOT USED
AD22	PSCIO15	I	3.3V	INPUT PORT (RPS)
AD23	NC	-	-	NOT USED
AD24	VSS	-	GND	GND
AD25	ASPCLK	I/O	3.3V	NCU INTERFACE
AD26	ARXD	I	3.3V	NCU INTERFACE
AE01	SDLDM1	O	3.3V	SDRAM DQML1
AE02	VSS	-	GND	GND
AE03	SYSPLLSS1	-	GND	GND
AE04	RTCCLKOUT	O	3.3V	CRYSTAL(32.768KHz) OUTPUT
AE05	RTCPWRDWN	I	3.3V	RTC POWER DOWN
AE06	TX_CLKI	I	3.3V	ETHERNET INTERFACE
AE07	TXD2	O	3.3V	ETHERNET INTERFACE
AE08	RX_CLKI	I	3.3V	ETHERNET INTERFACE
AE09	RXD3	I	3.3V	ETHERNET INTERFACE
AE10	MDC	O	3.3V	ETHERNET INTERFACE
AE11	NC	-	-	NOT USED
AE12	USBID	O	3.3V	NOT USED
AE13	USBDM	I/O	3.3V	USB INTERFACE
AE14	USBVSSA12_SQ	-	GND	GND
AE15	USBVDDA12PLL	-	1.2V	POWER SUPPLY
AE16	USBVDDA12	-	1.2V	POWER SUPPLY
AE17	LSI_TDI	I	3.3V	NOT USED
AE18	LSI_PROCMON	O	3.3V	NOT USED
AE19	LSI_IDDT	I	3.3V	NOT USED
AE20	PSCIO1	I	3.3V	INPUT PORT (PICK)
AE21	PSCIO5	O	3.3V	NOT USED
AE22	PSCIO13	I	3.3V	INPUT PORT (TNR)
AE23	MDMCLKOUT	O	3.3V	CRYSTAL(24.576MHz) OUTPUT
AE24	MDMPLLVD	-	3.3V	POWER SUPPLY
AE25	VSS	-	GND	GND
AE26	ABITCLK	I/O	3.3V	NCU INTERFACE
AF02	SYSPLLVDD1	-	3.3V	POWER SUPPLY
AF03	VDD3.3OSC	-	3.3V	POWER SUPPLY
AF04	RTCCLKIN	I	3.3V	CRYSTAL(32.768KHz) INPUT
AF05	COL	I	3.3V	ETHERNET INTERFACE
AF06	TX_EN	O	3.3V	ETHERNET INTERFACE
AF07	TXD3	O	3.3V	ETHERNET INTERFACE
AF08	RXD0	I	3.3V	ETHERNET INTERFACE
AF09	MDIO	I/O	3.3V	ETHERNET INTERFACE
AF10	MGTINT	I	3.3V	ETHERNET INTERFACE
AF11	USBVBUS	O	3.3V	USB INTERFACE
AF12	USBVDDA33_BIAS	-	3.3V	POWER SUPPLY
AF13	USBDP	I/O	3.3V	USB INTERFACE
AF14	USBVDDA33	-	3.3V	POWER SUPPLY
AF15	USBVSSA12PLL	-	GND	GND

PIN NO.	PinName	I/O	POWER SUPPLY VOLTAGE	EXPLANATION
AF16	USBXOUT	I	3.3V	CRYSTAL(12MHz) OUTPUT
AF17	LSI_TMS	I	3.3V	NOT USED
AF18	LSI_TCK	I	3.3V	NOT USED
AF19	LSI_CW_TAP	I	3.3V	NOT USED
AF20	PSCIO0	I	3.3V	INPUT PORT (REGIST)
AF21	PSCIO4	O	3.3V	NOT USED
AF22	PSCIO12	I	3.3V	INPUT PORT (POUT)
AF23	PSCIO14	I	3.3V	INPUT PORT (DOCU)
AF24	MDMCLKIN	I	3.3V	CRYSTAL(24.576MHz) INPUT
AF25	MDMPLLSS	-	GND	GND
B01	AFEADC0	I	3.3V	NOT USED
B02	VSS	-	GND	GND
B03	LEDONG	O	3.3V	SCANNER INTERFACE
B04	AFERSMP	O	3.3V	NOT USED
B05	AFEVSMP	O	3.3V	SCANNER INTERFACE
B06	NCCDRS	O	3.3V	SCANNER INTERFACE
B07	PIO30	I/O	3.3V	OPERATION PANEL INTERFACE
B08	MMPWR	O	3.3V	NOT USED
B09	PIO54	O	3.3V	CARRIAGE/ADF MOTOR INTERFACE
B10	PIO51	O	3.3V	CARRIAGE/ADF MOTOR INTERFACE
B11	PIO47	O	3.3V	NOT USED
B12	PIO43	O	3.3V	DC MOTOR INTERFACE
B13	NFROE	O	3.3V	FLASH MEMORY CHIP OUTPUT ENABLE
B14	FRMD1	I/O	3.3V	FLASH MEMORY DATA BUS 1
B15	FRMD4	I/O	3.3V	FLASH MEMORY DATA BUS 4
B16	FRMA0	O	3.3V	FLASH MEMORY ADDRESS BUS 0
B17	FRMA4	O	3.3V	FLASH MEMORY ADDRESS BUS 4
B18	FRMA7	O	3.3V	FLASH MEMORY ADDRESS BUS 7
B19	THRMVSS	-	GND	GND
B20	TONE	O	3.3V	ANALOG(TONE) OUTPUT
B21	FRMA12	O	3.3V	FLASH MEMORY ADDRESS BUS 12
B22	FRMA16	O	3.3V	FLASH MEMORY ADDRESS BUS 16
B23	FRMA19	O	3.3V	FLASH MEMORY ADDRESS BUS 19
B24	FRMA21	O	3.3V	FLASH MEMORY ADDRESS BUS 21
B25	VSS	-	GND	GND
B26	DOTPLLSS	-	GND	GND
C01	AFEADC3	I	3.3V	NOT USED
C02	AFEADC1	I	3.3V	NOT USED
C03	VSS	-	GND	GND
C04	LEDONR	O	3.3V	SCANNER INTERFACE
C05	OEB	O	3.3V	NOT USED
C06	CCDSH	O	3.3V	SCANNER INTERFACE
C07	PIO31	O	3.3V	OPERATION PANEL INTERFACE
C08	OPMPWR	O	3.3V	NOT USED
C09	PIO55	O	3.3V	CARRIAGE/ADF MOTOR INTERFACE
C10	PIO52	O	3.3V	CARRIAGE/ADF MOTOR INTERFACE
C11	PIO49	O	3.3V	OUTPUT PORT(HSSPMUTE)
C12	PIO45	O	3.3V	DC MOTOR INTERFACE
C13	NFRWE	O	3.3V	FLASH MEMORY CHIP WRITE ENABLE
C14	FRMD2	I/O	3.3V	FLASH MEMORY DATA BUS 2
C15	FRMD6	I/O	3.3V	FLASH MEMORY DATA BUS 6
C16	FRMA2	O	3.3V	FLASH MEMORY ADDRESS BUS 2
C17	FRMA5	O	3.3V	FLASH MEMORY ADDRESS BUS 5
C18	FRMA9	O	3.3V	FLASH MEMORY ADDRESS BUS 9
C19	THRMSTR0	I	3.3V	ANALOG INPUT(THERMISTOR)
C20	TONEAVDD	-	3.3V	POWER SUPPLY
C21	FRMA14	O	3.3V	FLASH MEMORY ADDRESS BUS 14
C22	FRMA18	O	3.3V	FLASH MEMORY ADDRESS BUS 18
C23	FRMA23	O	3.3V	FLASH MEMORY ADDRESS BUS 23
C24	VSS	-	GND	GND
C25	DOTPLLDD	-	3.3V	POWER SUPPLY
C26	DOTCLKIN	I	3.3V	CRYSTAL(20MHz) INPUT
D01	AFEADC5	I	3.3V	SCANNER INTERFACE
D02	AFEADC4	I	3.3V	SCANNER INTERFACE
D03	AFEADC2	I	3.3V	NOT USED
D04	VSS	-	GND	GND
D05	VSS	-	GND	GND

PIN NO.	PinName	I/O	POWER SUPPLY VOLTAGE	EXPLANATION
D06	VDD1.2	-	1.2V	POWER SUPPLY
D07	PIO32	O	3.3V	OPERATION PANEL INTERFACE
D08	CRMPWR	O	3.3V	MOTOR CURRENT CONTROL
D09	PIO56	O	3.3V	ADF MOTOR INTERFACE
D10	VDD1.2	-	1.2V	POWER SUPPLY
D11	PIO48	O	3.3V	NOT USED
D12	PIO44	O	3.3V	DC MOTOR INTERFACE
D13	VDD3.3	-	3.3V	POWER SUPPLY
D14	VDD1.2	-	1.2V	POWER SUPPLY
D15	FRMD5	I/O	3.3V	FLASH MEMORY DATA BUS 5
D16	FRMA1	O	3.3V	FLASH MEMORY ADDRESS BUS 1
D17	VDD3.3	-	3.3V	POWER SUPPLY
D18	FRMA8	O	3.3V	FLASH MEMORY ADDRESS BUS 8
D19	THRMSTR1	I	3.3V	ANALOG INPUT(THERMISTOR)
D20	TONEAVSS	-	GND	GND
D21	FRMA13	O	3.3V	FLASH MEMORY ADDRESS BUS 13
D22	VDD1.2	-	1.2V	POWER SUPPLY
D23	VSS	-	GND	GND
D24	NC	-	-	NOT USED
D25	DOTCLKOUT	O	3.3V	CRYSTAL(20MHz) OUTPUT
D26	PIO66	O	3.3V	NOT USED
E01	SDUDM0	O	3.3V	SDRAM DQMU0
E02	AFEADC7	I	3.3V	SCANNER INTERFACE
E03	AFEADC6	I	3.3V	SCANNER INTERFACE
E04	VSS	-	GND	GND
E23	VDD1.2	-	1.2V	POWER SUPPLY
E24	FRMA24	O	3.3V	FLASH MEMORY ADDRESS BUS 24
E25	PIO65	O	3.3V	NOT USED
E26	PIO64	O	3.3V	NOT USED
F01	SDMD16	I/O	3.3V	SDRAM DATA BUS 16
F02	SDMD17	I/O	3.3V	SDRAM DATA BUS 17
F03	AFESIFCLK	O	3.3V	SCANNER INTERFACE
F04	VDD1.2	-	1.2V	POWER SUPPLY
F23	PIO24	I	3.3V	LSU INTERFACE
F24	PIO61	O	3.3V	OUTPUT PORT(SPMUTE)
F25	PIO60	O	3.3V	NOT USED
F26	PIO3	O	3.3V	LSU INTERFACE
G01	SDMD18	I/O	3.3V	SDRAM DATA BUS 18
G02	SDMD19	I/O	3.3V	SDRAM DATA BUS 19
G03	AFESIFDIN	I	3.3V	SCANNER INTERFACE
G04	AFESIFEN	O	3.3V	SCANNER INTERFACE
G23	PSCIO24	I	3.3V	LSU INTERFACE
G24	PIO2	O	3.3V	LSU INTERFACE
G26	PIO58	O	3.3V	OUTPUT PORT(CIDRLY)
H01	SDMD20	I/O	3.3V	SDRAM DATA BUS 20
H02	SDMD21	I/O	3.3V	SDRAM DATA BUS 21
H03	NSDCS2	O	3.3V	SDRAM CHIP SELECT 2
H04	AFESIFDOUT	O	3.3V	SCANNER INTERFACE
H23	PIO63	O	3.3V	LSU INTERFACE
H24	PIO62	O	3.3V	LSU INTERFACE
H25	PIO28	O	3.3V	NOT USED
H26	PIO21	O	3.3V	LSU INTERFACE
J01	SDMD22	I/O	3.3V	SDRAM DATA BUS 22
J02	SDMD23	I/O	3.3V	SDRAM DATA BUS 23
J03	SDMA3	O	3.3V	SDRAM ADDRESS BUS 3
J04	SDMA2	O	3.3V	SDRAM ADDRESS BUS 2
J23	PIO6	O	3.3V	HIGH VOLTAGE UNIT INTERFACE
J24	PIO27	O	3.3V	NOT USED
J25	PIO5	O	3.3V	HIGH VOLTAGE UNIT INTERFACE
J26	PIO4	O	3.3V	HIGH VOLTAGE UNIT INTERFACE
K01	VSS	-	GND	GND
K02	SDCLK2	O	3.3V	SDRAM CLOCK 2
K03	VSS	-	GND	GND
K04	VDD3.3	-	3.3V	POWER SUPPLY
K23	VDD1.2	-	1.2V	POWER SUPPLY
K24	PIO41	O	3.3V	NOT USED
K25	PIO40	O	3.3V	NOT USED

PIN NO.	PinName	I/O	POWER SUPPLY VOLTAGE	EXPLANATION
K26	PIO39	O	3.3V	NOT USED
L01	SDMD24	I/O	3.3V	SDRAM DATA BUS 24
L02	SDMD25	I/O	3.3V	SDRAM DATA BUS 25
L03	SDMA1	O	3.3V	SDRAM ADDRESS BUS 1
L04	SDMAÇO	O	3.3V	SDRAM ADDRESS BUS 0
L11	VSS	-	GND	GND
L12	VSS	-	GND	GND
L13	VSS	-	GND	GND
L14	VSS	-	GND	GND
L15	VSS	-	GND	GND
L16	VSS	-	GND	GND
L23	PIO37	I	3.3V	INPUT PORT (RING)
L24	PIO38	O	3.3V	NOT USED
L25	PIO36	O	3.3V	NOT USED
L26	PIO35	O	3.3V	NOT USED
M01	SDMD26	I/O	3.3V	SDRAM DATA BUS 26
M02	SDMD27	I/O	3.3V	SDRAM DATA BUS 27
M03	SDMA10	O	3.3V	SDRAM ADDRESS BUS 10
M04	SDBA1	O	3.3V	SDRAM BANK ADDRESS 1
M11	VSS	-	GND	GND
M12	VSS	-	GND	GND
M13	VSS	-	GND	GND
M14	VSS	-	GND	GND
M15	VSS	-	GND	GND
M16	VSS	-	GND	GND
M23	PIO33	O	3.3V	NOT USED
M24	PIO34	O	3.3V	NOT USED
M25	PIO26	O	3.3V	NOT USED
M26	PIO25	O	3.3V	OUTPUT PORT(CNGMUTE)
N01	SDMD28	I/O	3.3V	SDRAM DATA BUS 28
N02	SDMD29	I/O	3.3V	SDRAM DATA BUS 29
N03	SDBA0	O	3.3V	SDRAM BANK ADDRESS 0
N04	VDD1.2	-	1.2V	POWER SUPPLY
N11	VSS	-	GND	GND
N12	VSS	-	GND	GND
N13	VSS	-	GND	GND
N14	VSS	-	GND	GND
N15	VSS	-	GND	GND
N16	VSS	-	GND	GND
N23	VDD3.3	-	3.3V	POWER SUPPLY
N24	PIO23	O	3.3V	NOT USED
N25	PIO22	O	3.3V	NOT USED
N26	PIO20	O	3.3V	NOT USED
P01	SDMD30	I/O	3.3V	SDRAM DATA BUS 30
P02	SDMD31	I/O	3.3V	SDRAM DATA BUS 31
P03	NSDCS	O	3.3V	SDRAM CHIP SELECT 1
P04	VDD3.3	-	3.3V	POWER SUPPLY
P11	VSS	-	GND	GND
P12	VSS	-	GND	GND
P13	VSS	-	GND	GND
P14	VSS	-	GND	GND
P15	VSS	-	GND	GND
P16	VSS	-	GND	GND
P23	VDD1.2	-	1.2V	POWER SUPPLY
P24	PIO16	I	3.3V	INPUT PORT
P25	PIO17	I	3.3V	INPUT PORT
P26	PIO18	I	3.3V	HIGH VOLTAGE UNIT INTERFACE
R01	SDUDM1	O	3.3V	SDRAM DQMU1
R02	SDLDM0	O	3.3V	SDRAM DQML0
R03	BZVDD33	-	3.3V	POWER SUPPLY
R04	BZRST33	-	3.3V	POWER SUPPLY
R11	VSS	-	GND	GND
R12	VSS	-	GND	GND
R13	VSS	-	GND	GND
R14	VSS	-	GND	GND
R15	VSS	-	GND	GND
R16	VSS	-	GND	GND

PIN NO.	PinName	I/O	POWER SUPPLY VOLTAGE	EXPLANATION
R23	PIO13	O	3.3V	NOT USED
R24	PIO12	O	3.3V	NOT USED
R25	PIO14	O	3.3V	NOT USED
R26	PIO15	I	3.3V	INPUT PORT
T01	SDMD0	I/O	3.3V	SDRAM DATA BUS 0
T02	SDMD1	I/O	3.3V	SDRAM DATA BUS 1
T03	NSDCAS	O	3.3V	SDRAM CAS
T04	NSDRAS	O	3.3V	SDRAM RAS
T11	VSS	-	GND	GND
T12	VSS	-	GND	GND
T13	VSS	-	GND	GND
T14	VSS	-	GND	GND
T15	VSS	-	GND	GND
T16	VSS	-	GND	GND
T23	PIO9	O	3.3V	OUTPUT PORT(SNPICK)
T24	PIO8	O	3.3V	NOT USED
T25	PIO10	O	3.3V	NOT USED
T26	PIO11	O	3.3V	OUTPUT PORT(SNREG)
U01	SDMD2	I/O	3.3V	SDRAM DATA BUS 2
U02	SDMD3	I/O	3.3V	SDRAM DATA BUS 3
U03	NSDWE	O	3.3V	SDRAM WRITE ENABLE
U04	VDD1.2	-	1.2V	POWER SUPPLY
U23	VDD3.3	-	3.3V	POWER SUPPLY
U24	PIO0	I	3.3V	INPUT PORT (HOOK)
U25	PIO1	O	3.3V	OUTPUT PORT(EXTRLY)
U26	PIO7	O	3.3V	NOT USED
V01	SDMD4	I/O	3.3V	SDRAM DATA BUS 4
V02	SDMD5	I/O	3.3V	SDRAM DATA BUS 5
V03	SDCKE	O	3.3V	SDRAM CLOCK ENABLE
V04	SDMA12	O	3.3V	SDRAM ADDRESS BUS 12
V23	PSCIO20	I	3.3V	INPUT PORT (CIS HOME)
V24	PSCIO21	O	3.3V	NOT USED
V25	PSCIO22	O	3.3V	NOT USED
V26	PSCIO23	O	3.3V	NOT USED
W01	SDMD6	I/O	3.3V	SDRAM DATA BUS 6
W02	SDMD7	I/O	3.3V	SDRAM DATA BUS 7
W03	SDMA11	O	3.3V	SDRAM ADDRESS BUS 11
W04	SDMA9	O	3.3V	SDRAM ADDRESS BUS 9
W23	PSCIO16	O	3.3V	NOT USED
W24	PSCIO17	I	3.3V	INPUT PORT (FANDET2)
W25	PSCIO18	I	3.3V	INPUT PORT (TOPCVR)
W26	PSCIO19	I	3.3V	INPUT PORT (PSTART)
Y01	VSS	-	GND	GND
Y02	SDCLK	O	3.3V	SDRAM CLOCK 1
Y03	SDMA8	O	3.3V	SDRAM ADDRESS BUS 8
Y04	VSS	-	GND	GND
Y23	AFESELO	I	3.3V	NCU INTERFACE
Y24	AFESEL1	I	3.3V	NCU INTERFACE
Y25	EXMDMCS	O	3.3V	NOT USED
Y26	DP	O	3.3V	NCU INTERFACE

6.3.2. RTC Backup Circuit

1. Function

This unit has a lithium battery (BAT300) which works for the Real Time Clock IC (RTC: inside IC300). The RTC continues to work, backed up by a lithium battery even when the power switch is OFF.

2. RTC Inside (IC300) Backup Circuit Operation

When the power switch is turned ON, power is supplied to the RTC (inside IC300). At this time, the voltage at pin AF3 of the IC300 is +3.3V. When the power switch is turned OFF, the BAT300 supplies power to RTC through DA300. When the power switch is OFF and the voltage of +3.3V decreases, pin AF3 of RTC (IC300) becomes roughly the same voltage as the battery voltage. RTC goes into the backup mode, in which the power consumption is lower.

Circuit Diagram

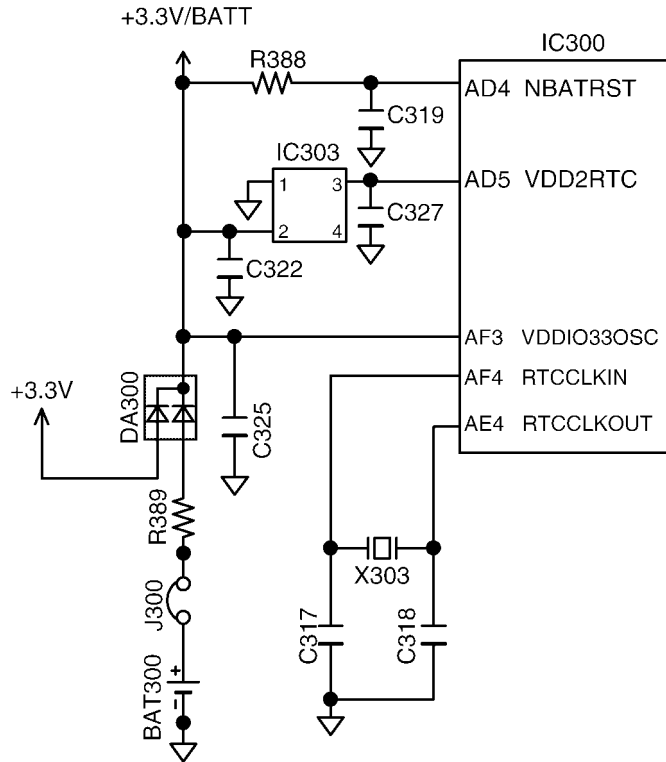

6.4. CIS Control Section

The scanning block of this device consists of a control circuit and a CIS (contact image sensor), and AFE(Analog Front End) include A/D Converter.

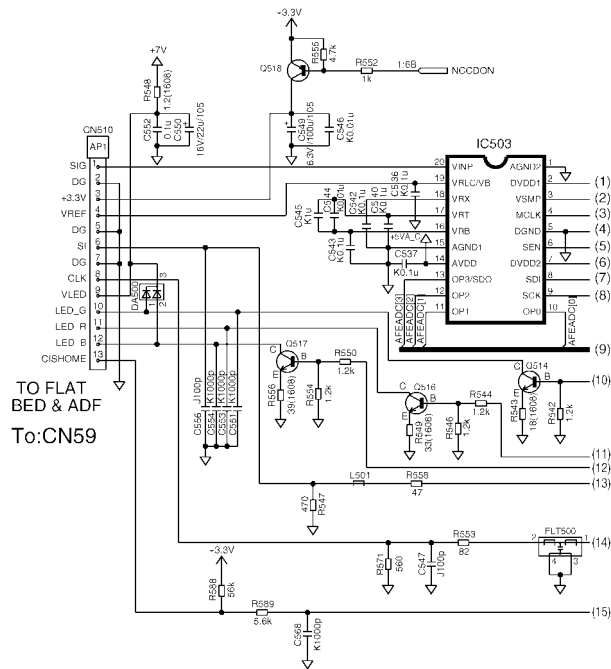
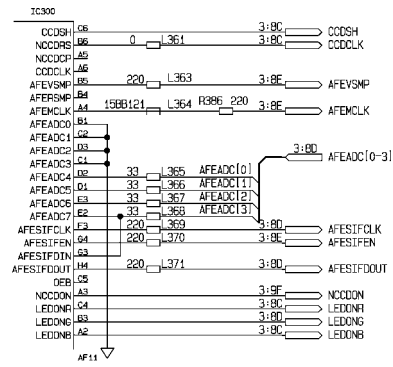

When an original document is inserted and the start button pressed, pin A3 of IC300 goes to a low level and the transistor Q518 turns on.

This applies voltage to the CIS. The CIS is driven by each of the CCDSH, CCDCLK signals output from IC300, and the original image illuminated by the LED to output an analog image signal.

The analog image signal is input to the AFE on VINP (20pin of IC503) and converted into 16-bit data by the A/D converter inside IC503. Then this signal undergoes digital processing in order to obtain a high-quality image.

6.5. Motor Drive Section

6.5.1. Engine Motor Control Circuit

1. Functions

All driving forces of printer engine part are supplied by this engine motor.

Engine motor is controlled so as to rotate at constant speed during printing and copying.

2. Motor operation

<Start operation>

In order to start the motor rotation, following 3 signals are supplied from IC300.

1. SS signal (Output pin: Pin B12/Output Signal: "H")

When this signal is inverted by transistor Q502 and becomes "L", motor recognize this signal as "start" signal.

2. Clock signal (Output pin: Pin A12/Output Signal: Pulse)

Pulse frequency :approx. 2.2KHz (at normal printing speed)

Pulse frequency :approx. 1.1KHz.(at half printing speed)

This signal is also inverted by transistor Q525, and supplied to motor as "clock" signal.

3. Brake signal (Output pin: Pin C12/Output Signal: "H")

When this signal is inverted by transistor Q526 and becomes "L", motor recognize this signal as "brake off" signal.

When motor reaches constant speed, "L" signal is supplied from motor to IC300 pin D12 as "Lock detect (LD)" signal.

If "LD" signal does not becomes "L" within predetermined period after "SS" signal becomes "H", or if "LD" signal becomes "H" during rotation, it is judged that motor Error occurred.

Timing Chart of Start operation

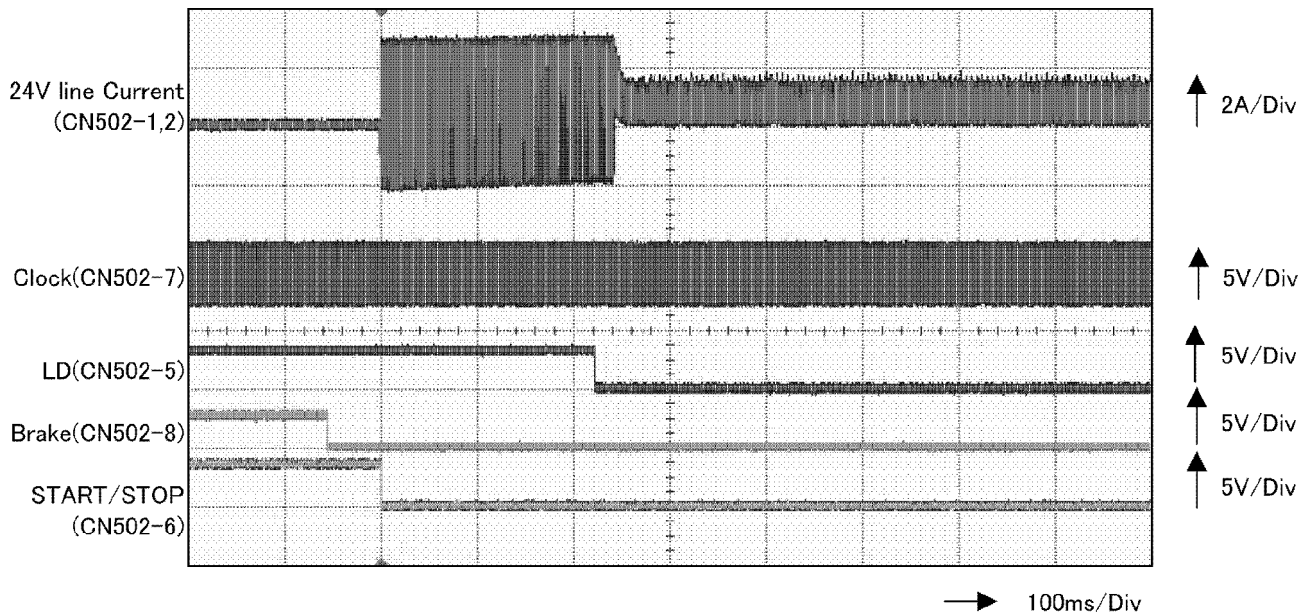

<Stop operation>

In order to stop the motor rotation, following 2 signals are supplied from IC300.

1. SS signal (Output pin: Pin B12/Output Signal: "L")

When this signal is inverted by transistor Q502 and becomes "H", motor recognize this signal as "stop" signal.

2. Brake signal (Output pin: Pin C12/Output Signal: "L")

When this signal is inverted by transistor Q526 and becomes "H", motor recognize this signal as "brake on" signal.

Timing Chart of Stop operation

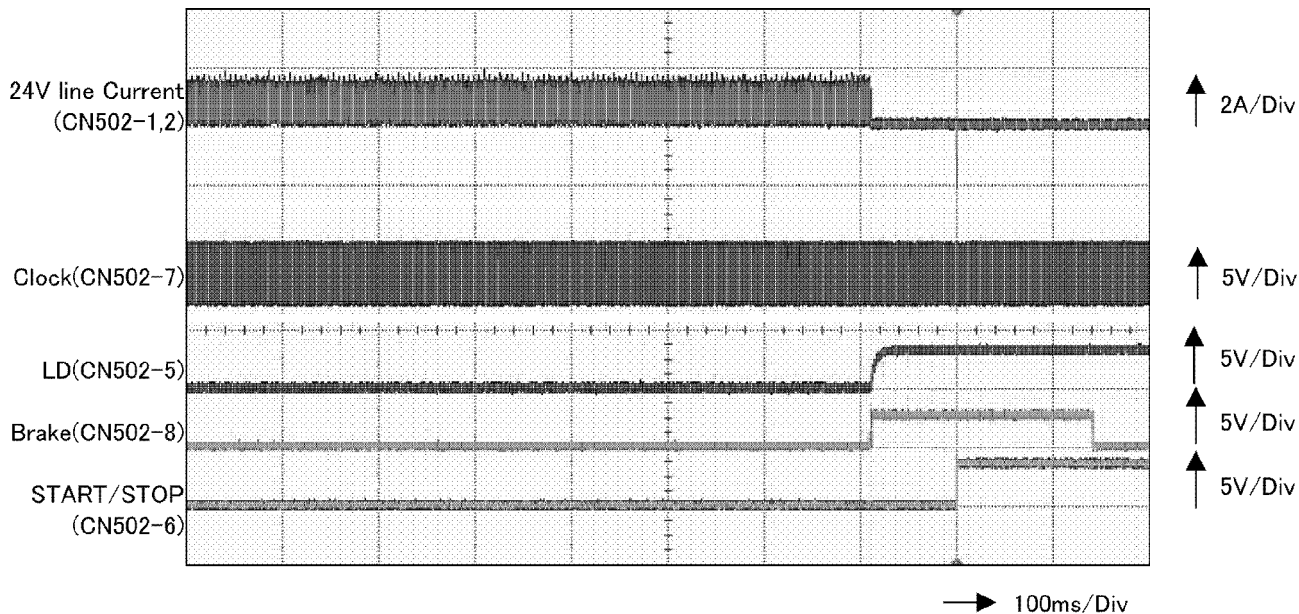

6.5.1.1. Engine Motor Drive Circuit

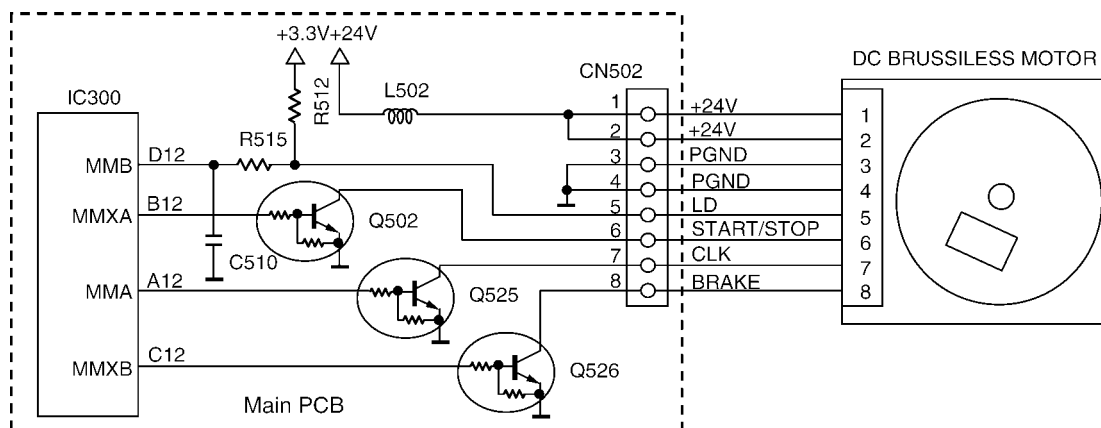

6.5.2. Scanner Motor Drive Circuit

General

Scanner motor drive circuit is consist of motor current control circuit ,FB (Flat Bed) motor driver, ADF (Auto Document Feeder: equipped model only) motor driver and OCP (Over Current Protection) circuit.

6.5.2.1. Motor current control circuit

1. Circuit explanation

According to the scan speed, each motor current is controlled for appropriate value.

When scan speed is low, motor current is reduced to prevent the vibration during motor rotation.

When scan speed is high, motor needs much driving force. so much current should be supplied.

For the control of motor current, Vref voltage of each motor driver is controlled.
 When Vref voltage is high, motor current is increased, and the voltage is low, motor current is reduced.
 In order to control the Vref voltage, PWM pulse is supplied from IC300 pin D8.
 PWM pulse is inverted by Q521 and integrated by R533, R534, and C509, then converted to DC voltage.

This DC voltage is supplied to Vref pin of each motor drivers.
 When duty of PWM pulse is high, Vref voltage is decreased and when duty is low, Vref voltage is increased.

For FB motor, motor current is controlled approx. 0.1A-0.25A.
 For ADF motor, motor current is controlled approx. 0.2A-0.35A (ADF equipped model only).

2. Circuit diagram of current control and OCP circuit

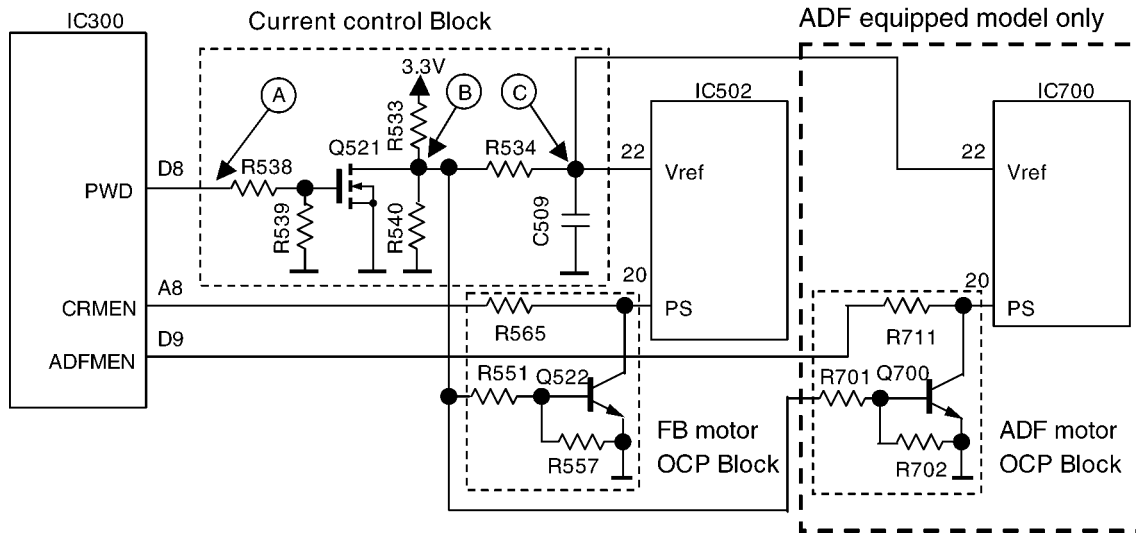

3. Timing chart

Following timing charts are the example when PWM pulse duty are approx 9% and 45%..

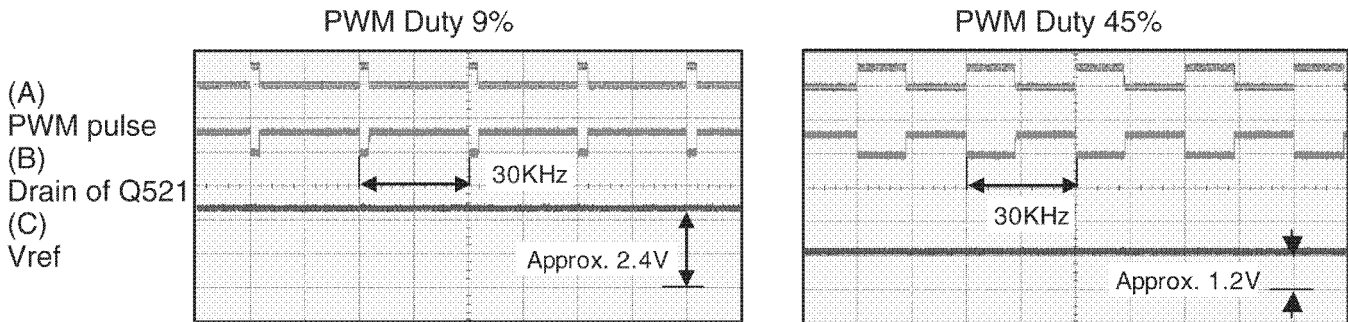

6.5.2.2. OCP (Over Current Protection) circuit

1. Functions

By parts failure or other reason, if Vref voltage exceeds 0.9V, extreme current is supplied to the motor. This may cause motor over heat and damage.

To prevent this problem, over current protection circuit is provided.

If Vref voltage becomes over 0.9V, Q522 or Q700 turns on. Then PS signal (pin20 of motor driver) becomes "L" and motor driver stops output the motor current.

2. Circuit Diagram

Refer to the circuit diagram in **Motor current control circuit** (P.27).

6.5.2.3. FB (Flat Bed) Motor Drive Circuit

1. Functions

This motor functions for main operations including, FB copy and PC scan.

This motor feeds CIS unit with synchronizing for reading.

2. Motor operation

During motor driving, pin A8 of IC 300 become "H" level, then motor driver IC502 is activated.

Stepping pulses are output from IC300 pins A9, B9, C9, A10, B10, and C10, causing driver IC502 pin 4, 6, 7 and 9 to drive the motor coil.

A 1-step rotation of this motor feeds 0.021mm of CIS unit.

3. Circuit Diagram

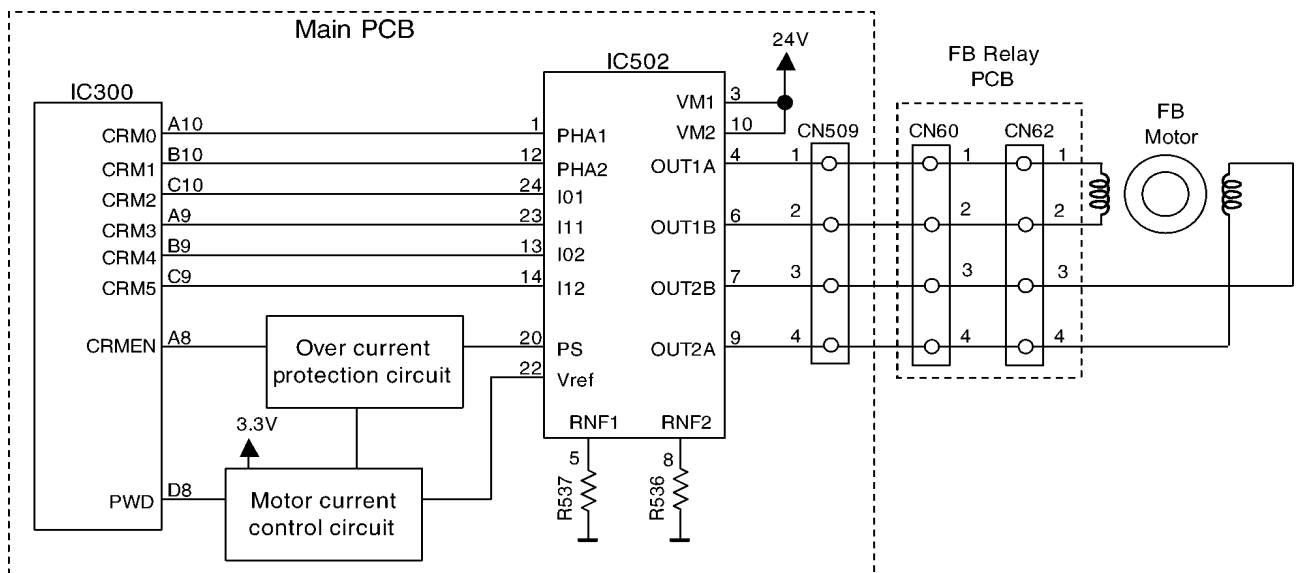

6.5.2.4. ADF (Auto Document Feeder) Motor drive circuit (KX-MB2010 ONLY)

1. Functions

This motor functions for main operations including, ADF copy and PC scan.

This motor feeds document, which are set to ADF with synchronizing for reading.

2. Motor operation

During motor driving, pin D9 of IC 300 become low level, then motor driver IC700 is activated.

Stepping pulses are output from IC300 pins A9, B9, C9, A10, B10, and C10, causing driver IC700 pin 4, 6, 7 and 9 to drive the motor coil.

A 1-step rotation of this motor feeds 0.042mm of document.

3. Circuit Diagram

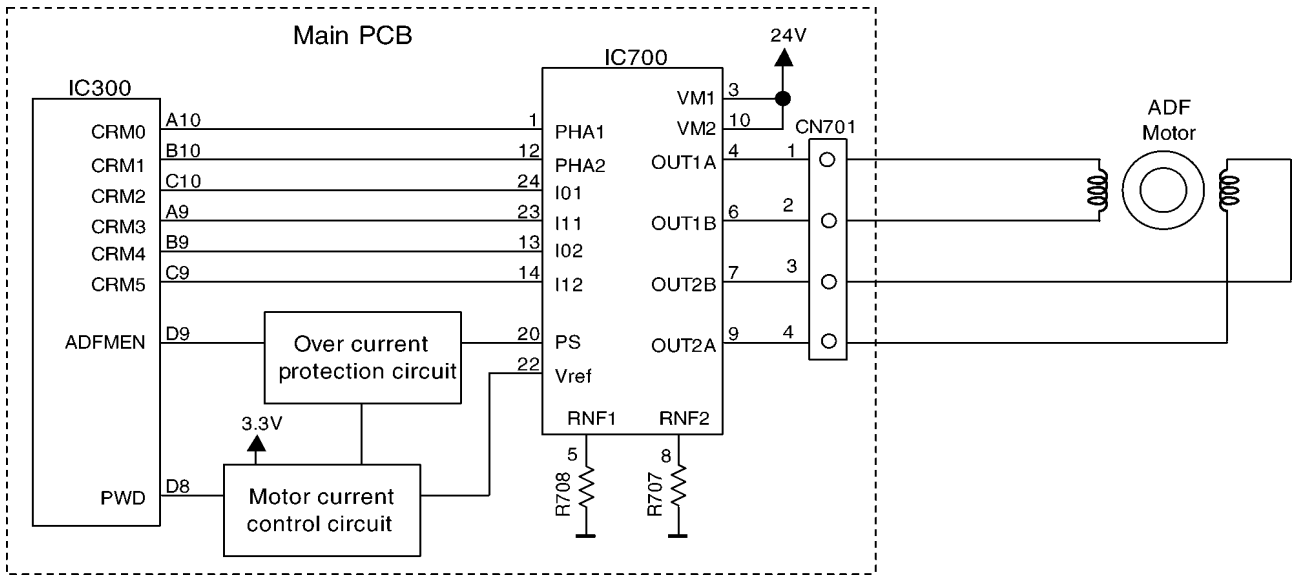

6.6. Timing chart and wave form of scanner motors

Control sequence and waveform of both FB and ADF motor are almost same.

6.6.1. Normal 1-2 phase excitation (half step)

1. Timing chart

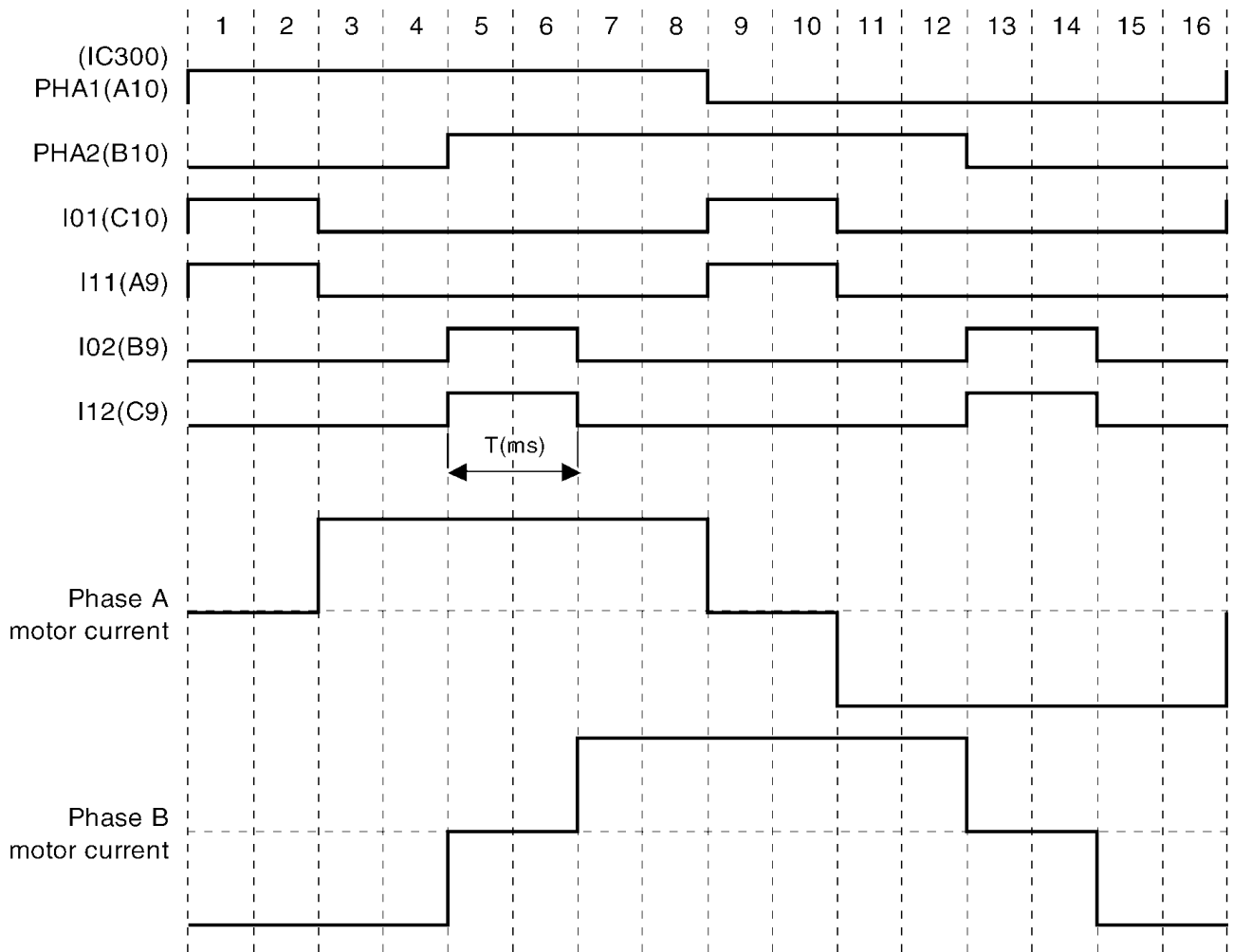

2. Wave form

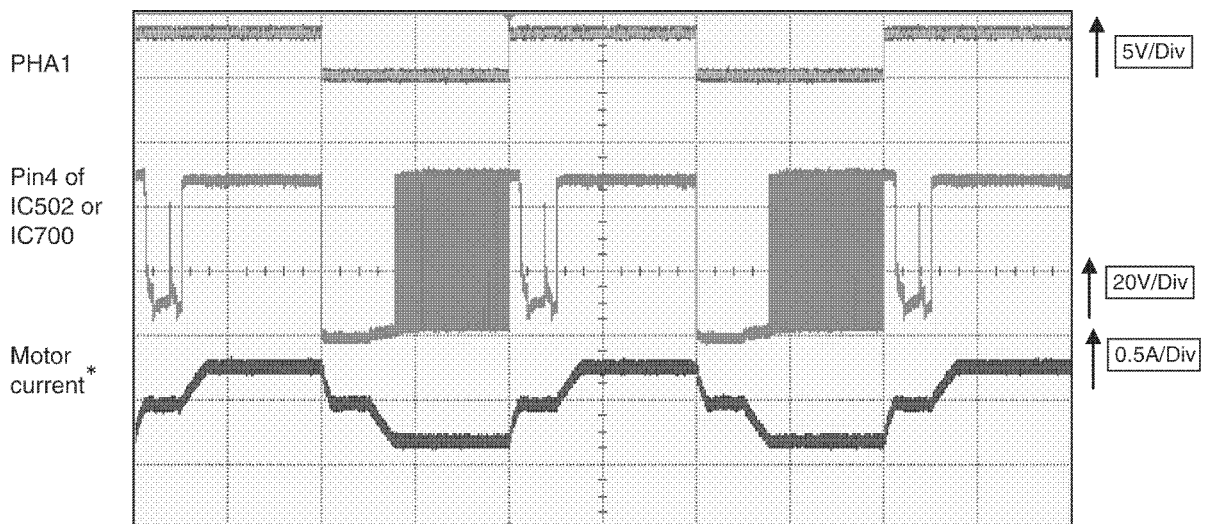
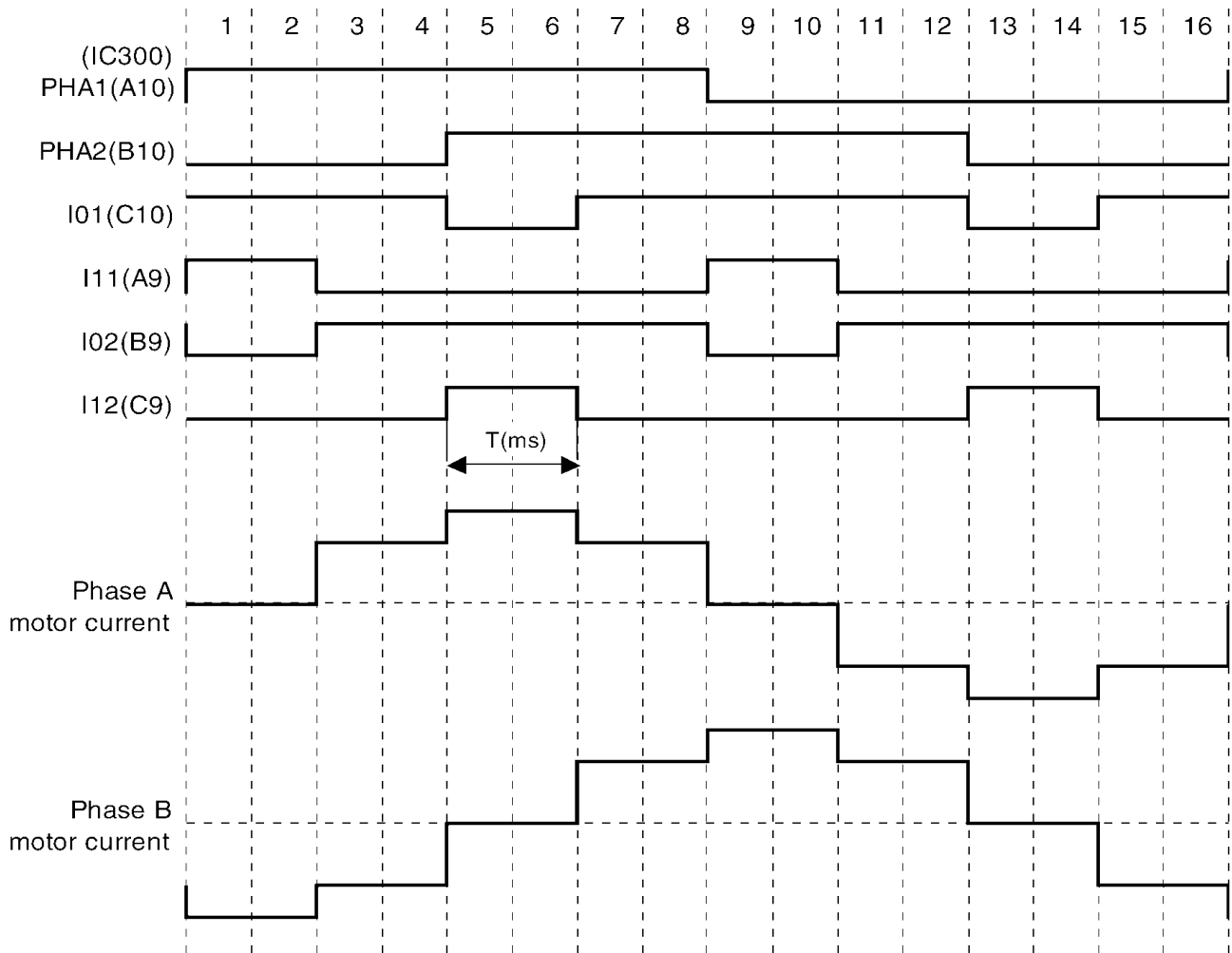

Fig. 1

* Motor current is changed according to the scan speed.

6.6.2. Flat torque 1-2 phase excitation (half step)

1. Timing chart



2. Wave form

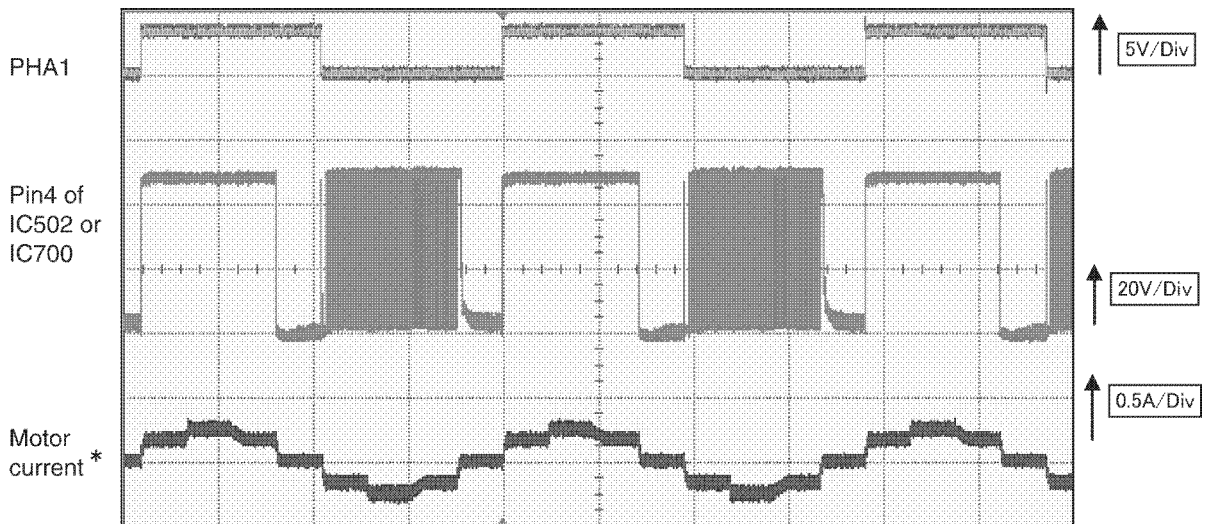
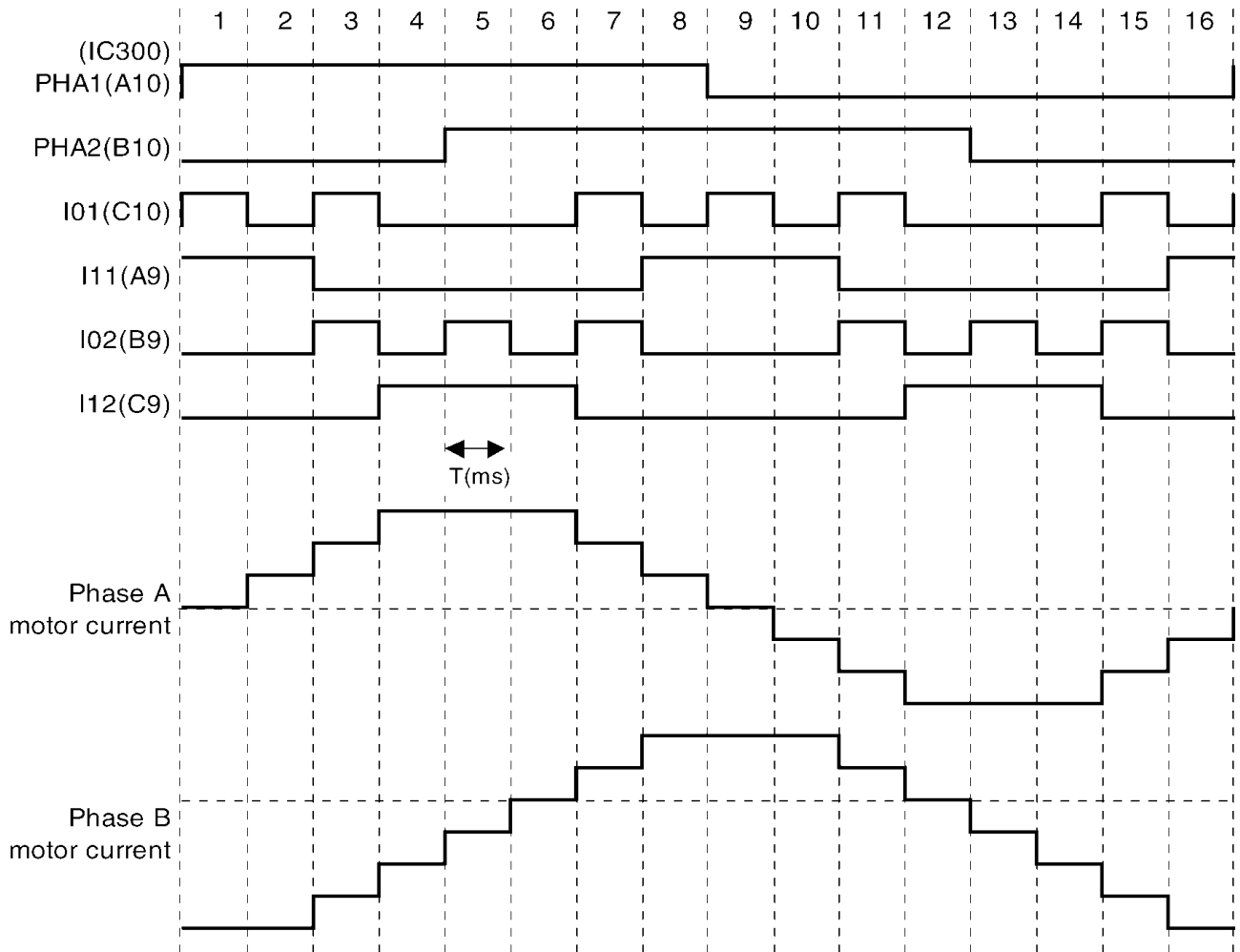

Fig. 2

* Motor current is changed according to the scan speed.

6.6.3. W1-2 phase excitation (Quarter step)

1. Timing chart



2. Wave form

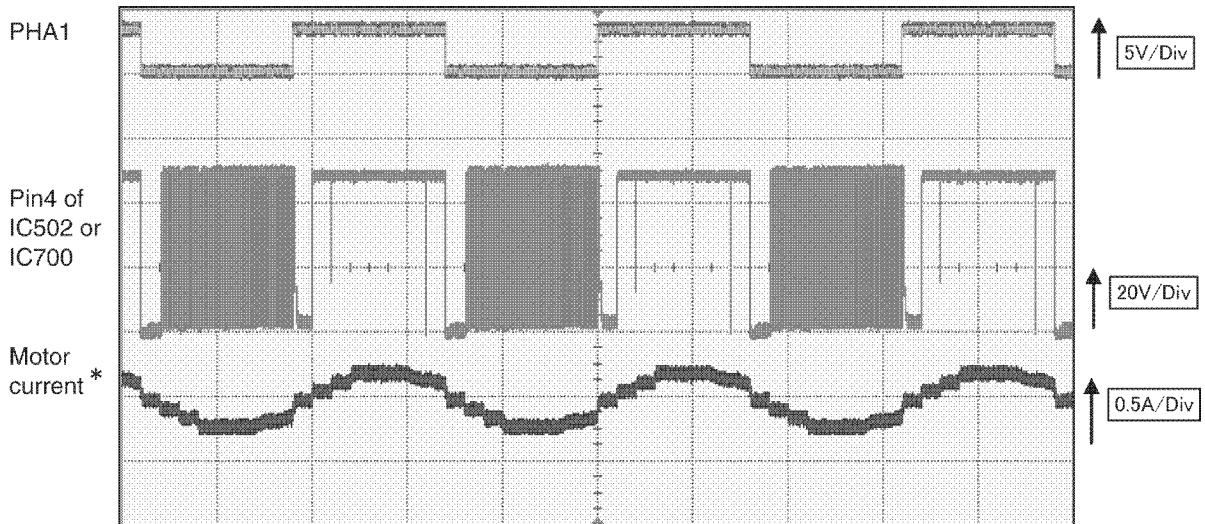

Fig. 3

* Motor current is changed according to the scan speed.

6.6.4. Drive mode of FB and ADF motor

Correspondent table of operation

Operation	Color mode	ADF/FB	Time & Figure	Resolution (dpi)							
				Pre Scan	75 x 75	100 x 100	150 x 150	200 x 200	300 x 300	400 x 400	600 x 600
PC scan	Color	ADF*	T(msec)	1.0		2.5		2.0			
			Figure	②				③			
		FB	T(msec)	0.5		2.0					
			Figure	②				③			
	Black & White	ADF*	T(msec)	0.67				1.33			
			Figure	①				②			
		FB	T(msec)	0.22		0.67		1.33			
			Figure	①		②					

Operation	Color mode	ADF/FB	Time & Figure	Copy magnification							
				100%			other than 100%				
				Copy mode							
				Photo/Text	Text	Photo	Photo/Text	Text	Photo		
Copy	Black & White	ADF* (non Sort)	T(msec)	0.67		1.33		0.67		1.33	
			Figure	①		②		①		②	
		ADF* (Sort)	T(msec)	0.67				1.33			
			Figure	①				②			
		FB	T(msec)	0.67							
			Figure	②							

* KX-MB2010 ONLY

6.7. FAN Motor Section

6.7.1. General

This unit is equipped with two FAN motors to prevent the developing devices, Power Supply Unit (PSU) and other devices from overheating during printing.

The FAN rotates at high speed (Approx. 3000rpm) while printing.

After printing is finished, FAN rotates at low speed (Approx.2200rpm) while predetermined period.

6.7.2. Circuit Diagram of FAN

Two FAN motors are controlled by following one circuit.

So the operation of two FAN motors (Full speed rotation/Half speed rotation/Stop) are controlled simultaneously.

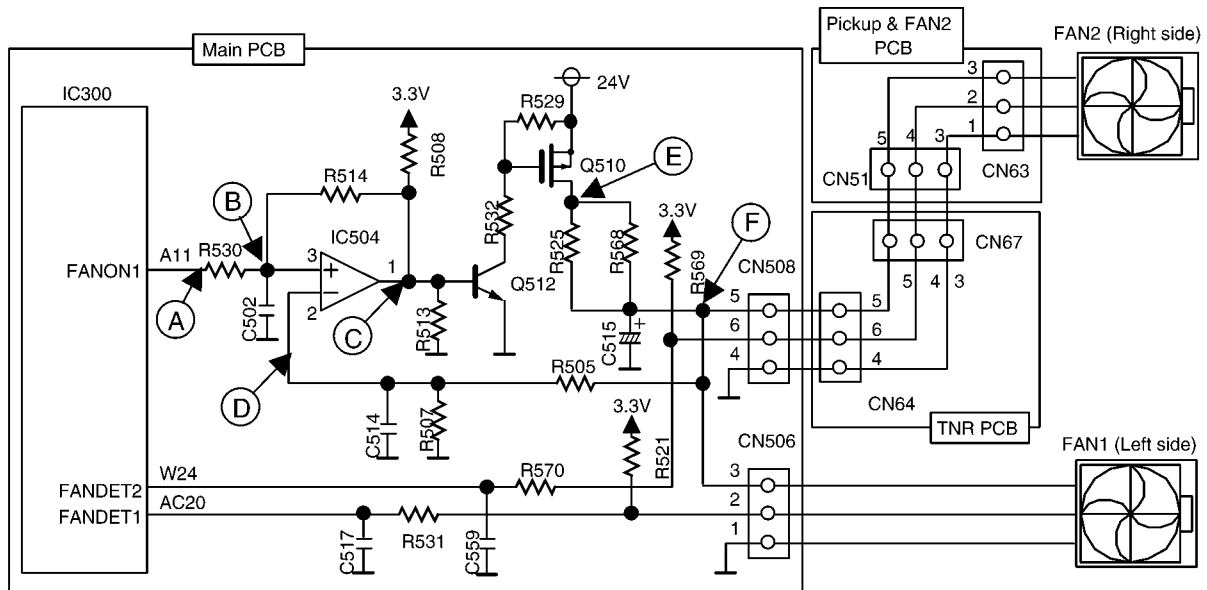

6.7.3. Fan Control

For the control of FAN speed, comparator IC (IC504) is used.

This IC compares (+) side input level and (-) side input level.

If (+) side input level is bigger than (-) side input level, output of this IC is "OPEN".

If (+) side input level is less than (-) side input level, it outputs "L" level.

6.7.3.1. Half Speed Mode

In half speed mode, IC300_pinA11 outputs pulse (frequency is about 30KHz, duty is about 37.5%).

This pulse is integrated by R30 and C502 then Pin2_IC504 becomes approx. DC1.24V. Input level of IC504_pin2 is determined by the voltage of between R507.

If voltage between R507 is less than 1.24V, output of pin1_IC504 becomes "H".

Then both Q512 and Q510 are turned on. So voltage between R504 (=the voltage of pin2_IC504) rises gradually.

When the voltage between R507 exceeds 1.24V, output of pin1_IC504 becomes "L".

Then both Q512 and Q510 are turned off. So voltage between R507 falls gradually.

By repeating these sequences, voltage between R507 is controlled approx. 1.24V.

On the other hand, if FAN voltage is represented V_o and voltage between R507 is represented V_L , V_L is determined as below formula.

$$V_L = V_o \cdot R507 / (R505 + R507) \rightarrow V_o = V_L \cdot (R505 + R507) / R507$$

Since each value is as follows, V_o is determined approx. 9.7(V).

$$V_L = 1.24(V), R505 = 150(Kohm), R507 = 22(Kohm)$$

$$V_o = 1.24 \cdot (150K + 22K) / 22K = 9.7(V)$$

Therefore by reducing the voltage of FAN power supply, FAN rotates with half speed.

6.7.3.2. Full Speed Mode

In full speed mode, IC300_pinA11 outputs constant 3.3V.

When both Q512 and Q510 are turned on, V_o becomes 24V.

So the voltage between R507 is determined as follows

$$V_L = V_o \cdot R507 / (R505 + R507) = 24 \cdot 22K / (150K + 22K) = 3.07(V)$$

Since IC504_pinA3 is 3.3V and IC504_pinA2 is 3.07V, pin1_IC504 is always "H".

Consequently both Q512 and Q510 are always turned on, and then 24V is supplied to FAN motors.

Therefore FAN rotates with full speed.

6.7.3.3. FAN stop

When IC300_pinA11 is "L", both Q512 and Q510 are turned off, then both FAN stop.

6.7.3.4. Rotation detect signal

During the FAN rotation, the pulse signal is output from pin 2 of FAN motors as the rotation detects signals.

If the period of the pulse is wider than predetermined value, it is judged that FAN error occurred.

Then display shows "Call Service 4". (Refer to **CALL SERVICE 4** (P.101)).

6.7.4. Control table

FANON1H (IC300_pinA11)	FAN1and FAN2 mode
H	Full speed
Pulse	Half speed
L	Stop

6.7.5. Waveform

(1) Full speed (H:20usec/Div)

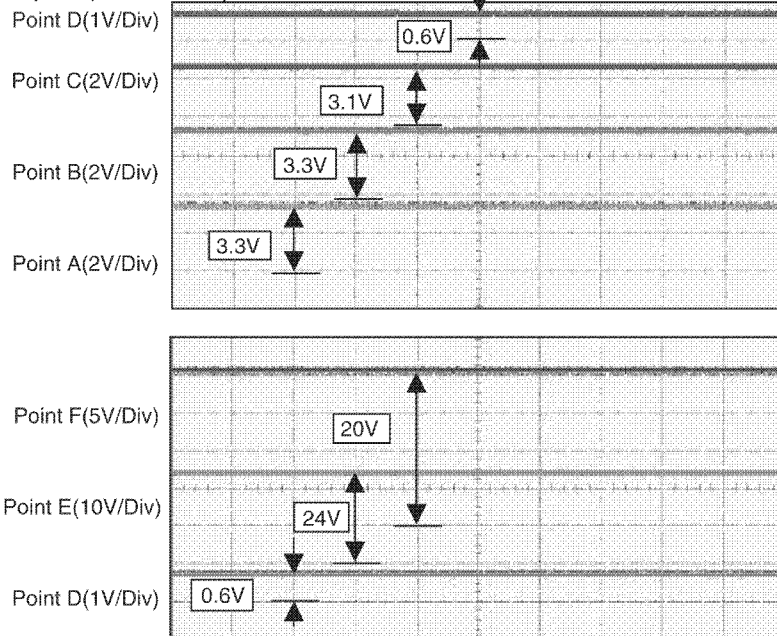

(2) Half speed (H:20usec/Div)

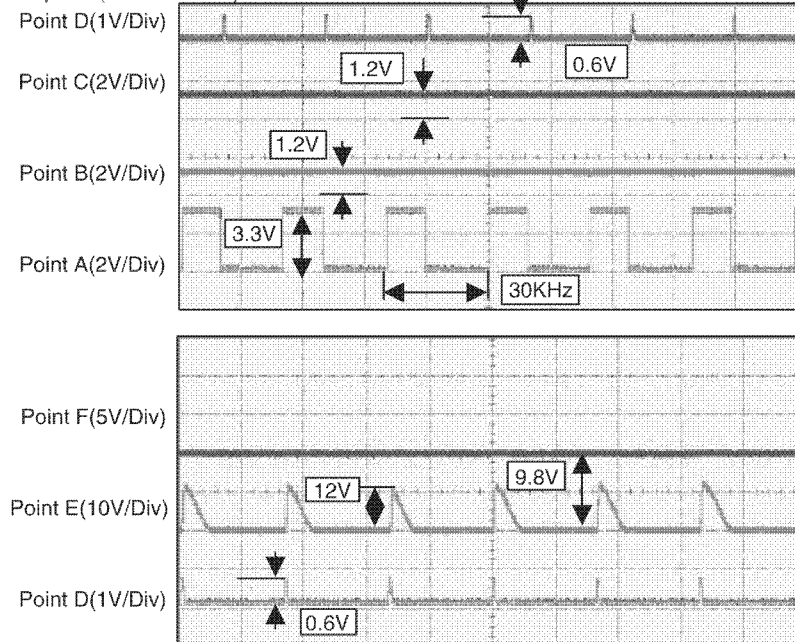

6.8. Solenoid Driver Section

The solenoid drive circuit controls Registration solenoid and Pick up Solenoid.

These solenoids are designed to be driven 24V.

The diodes protect transistors from reverse generated voltage when solenoids are turned off.

1. Circuit Diagram

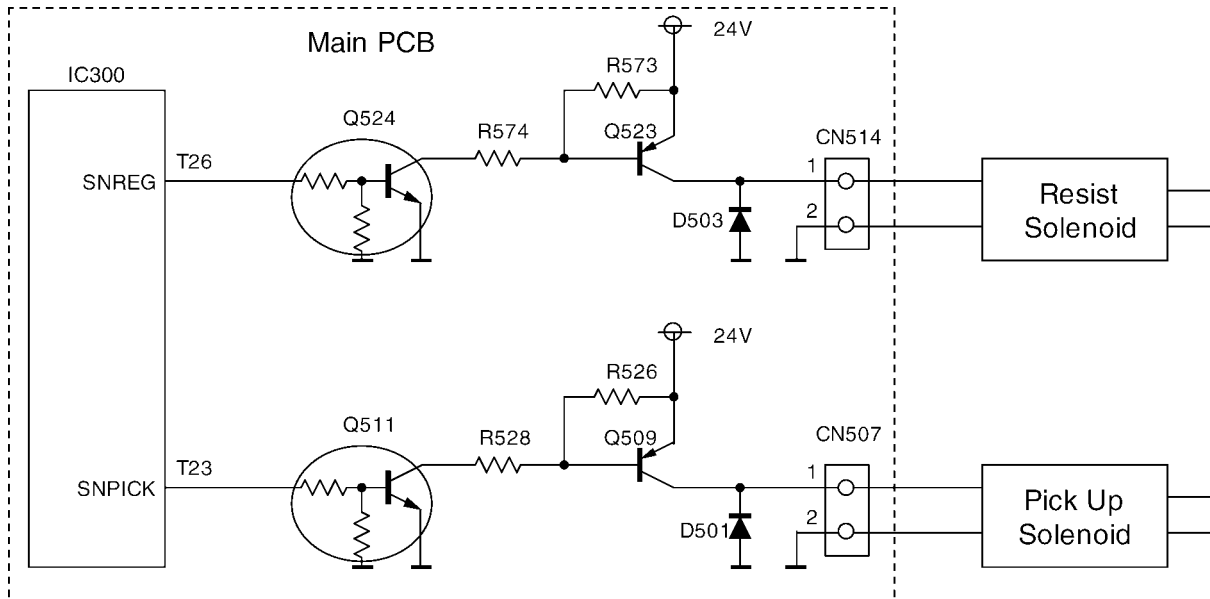

2. Active Logic

REGISTRATION	
MODE	IC300_T26
Solenoid ON	High level
Solenoid OFF	Low level

PICKUP	
MODE	IC300_T23
Solenoid ON	High level
Solenoid OFF	Low level

6.9. LSU (Laser Scanning Unit) Section

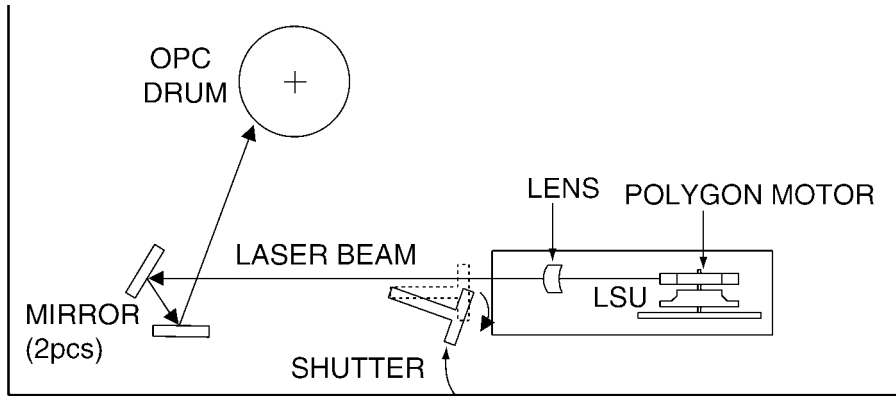

The mechanical shutter will be opened by setting DRUM UNIT properly.

LSU Layout

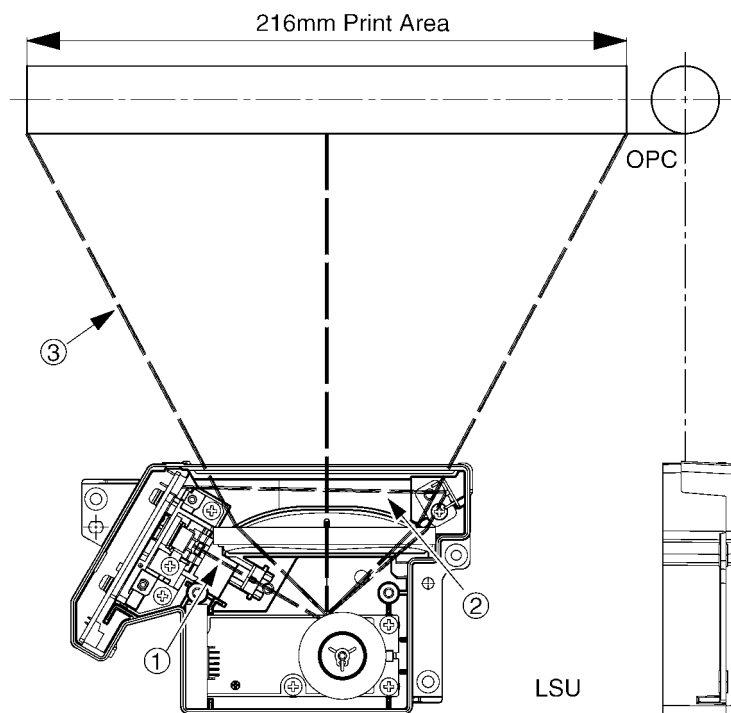

- ① Laser output
- ② OPC DRUM is irradiated with a laser.
- ③ The sensor outside the effective printing area detects the 1-line operation (scanning).

Circuit Diagram

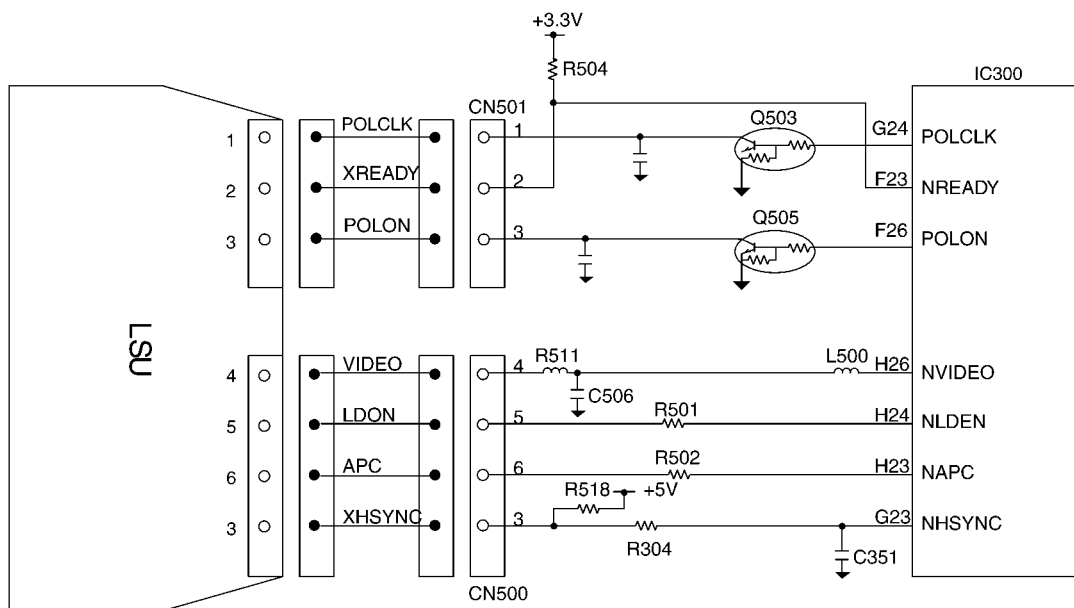

Timing Chart

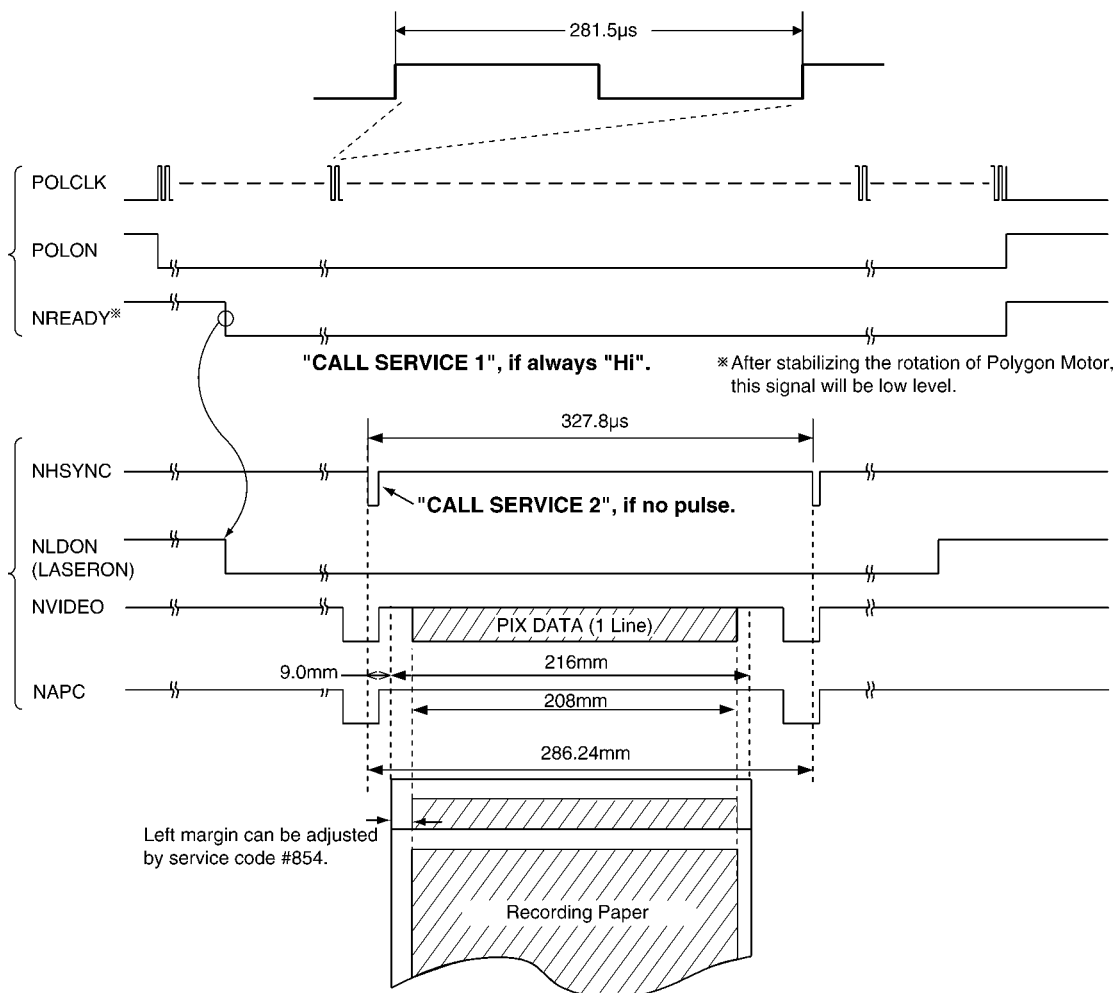

6.10. Sensors and Switches Section

All of the sensor and switches are shown below.

Sensor Name	Sensor Location	Reference number	Message Error
Pickup sensor	Pickup & Fan2 PCB	SW50	[PAPER JAMMED] [CHECK REAR CVR] [WRONG PAPER & PRESS START]
Exit sensor	Fuser PCB	PS50	[PAPER JAMMED]
Home sensor	CIS Home PCB	PS55	[SCANNER POSITION ERROR]
Read position sensor (KX-MB2010 ONLY)	ADF PCB	PS53	[CHECK DOCUMENT]
Registration & Manual paper sensor	Registration & PTOP PCB	PS51	[PAPER JAMMED]
Print timing sensor	Registration & PTOP PCB	PS52	[PAPER JAMMED]
Document sensor (KX-MB2010 ONLY)	ADF PCB	PS54	-
Top cover sensor	H.V.P.S	SW1	[TOP COVER OPEN]
Toner sensor	TONER PCB	IC51	[TONER EMPTY] [TONER LOW] [CHECK DRUM]

Note:

See TEST FUNCTIONS - SENSOR CHECK SECTION for the sensor test.

(#815 of Service Mode test. Refer to **Test Functions** (P.80).

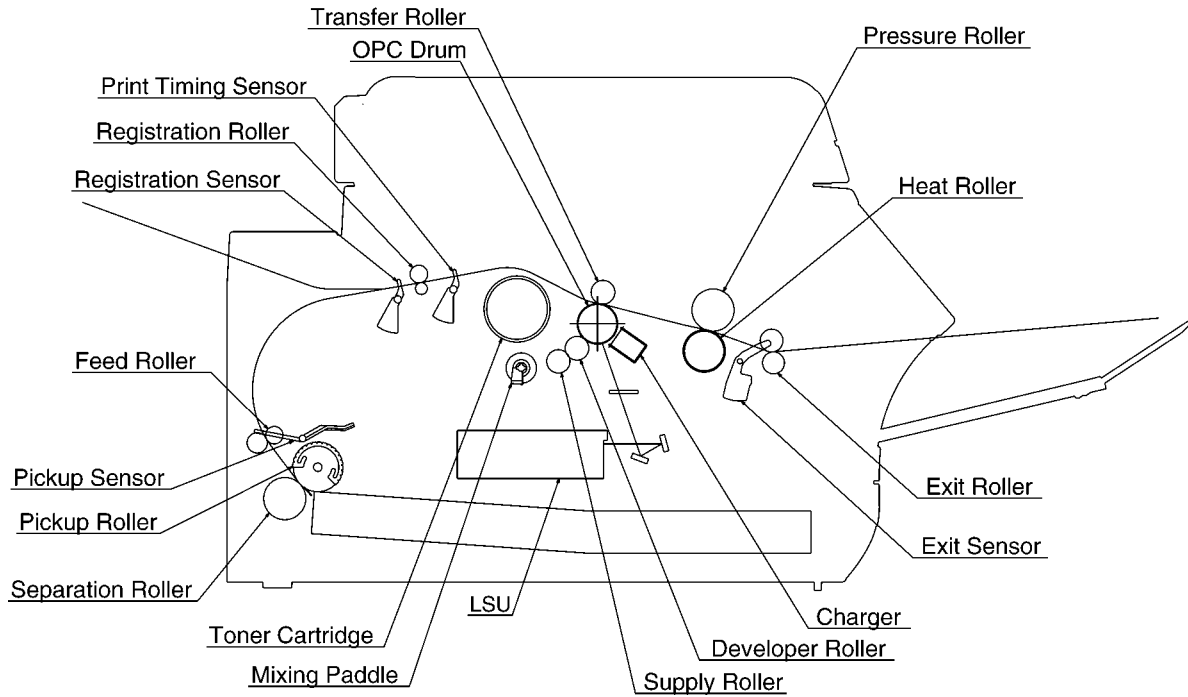

6.10.1. Drum Detection

DRUM SENSOR is not arranged.

DRUM cartridge is detected when HVERR SENSOR arranged in H.V.P.S becomes effective.

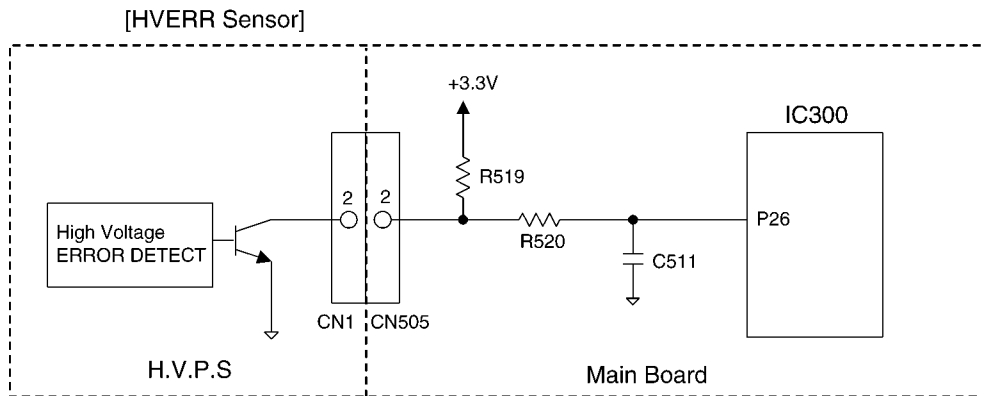

High Voltage ERROR Status	Drum sensor	Signal (IC300-P26)
Abnormal	DRUM can not be detected	Low level
Normal	DRUM can be detected	High level

6.10.2. Pickup Sensor

Paper SENSOR is not arranged.

Paper is detected when PICKUP SENSOR described as follows becomes effective.

This Switch detects whether a recording paper is picked up or not, and whether Rear Cover is opened or closed.

When there is a recording paper at the position of the switch, the input signal of IC300-AE20pin becomes low level.

When there is no recording paper at the position of the switch, the input signal of IC300-AE20pin becomes high level.

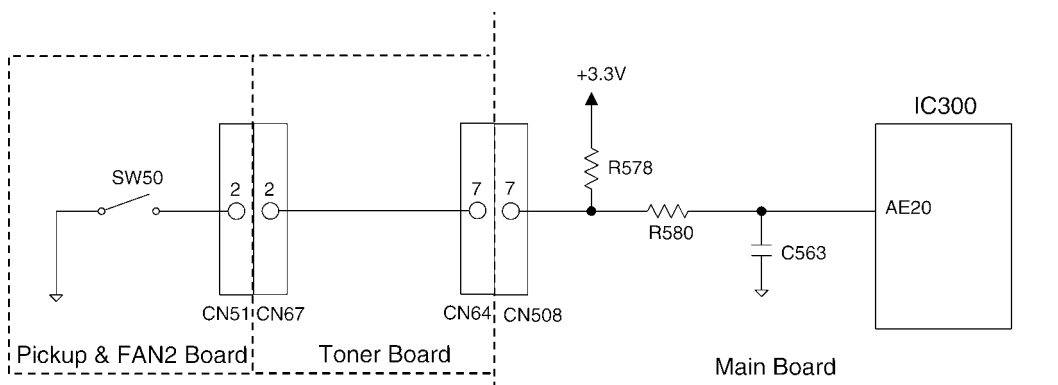

Pickup status	Idling status	Signal (IC300-AE20pin)
A paper exists	Rear Cover opened	Low level
No papers	Rear Cover closed	High level

6.10.3. Exit Sensor

This sensor detects whether the recording paper exits or not.

When there is a recording paper at the position of the sensor, the input signal of IC300-AD20pin becomes low level.

When there is no recording paper at the position of the sensor, the input signal of IC300-AD20pin becomes high level.

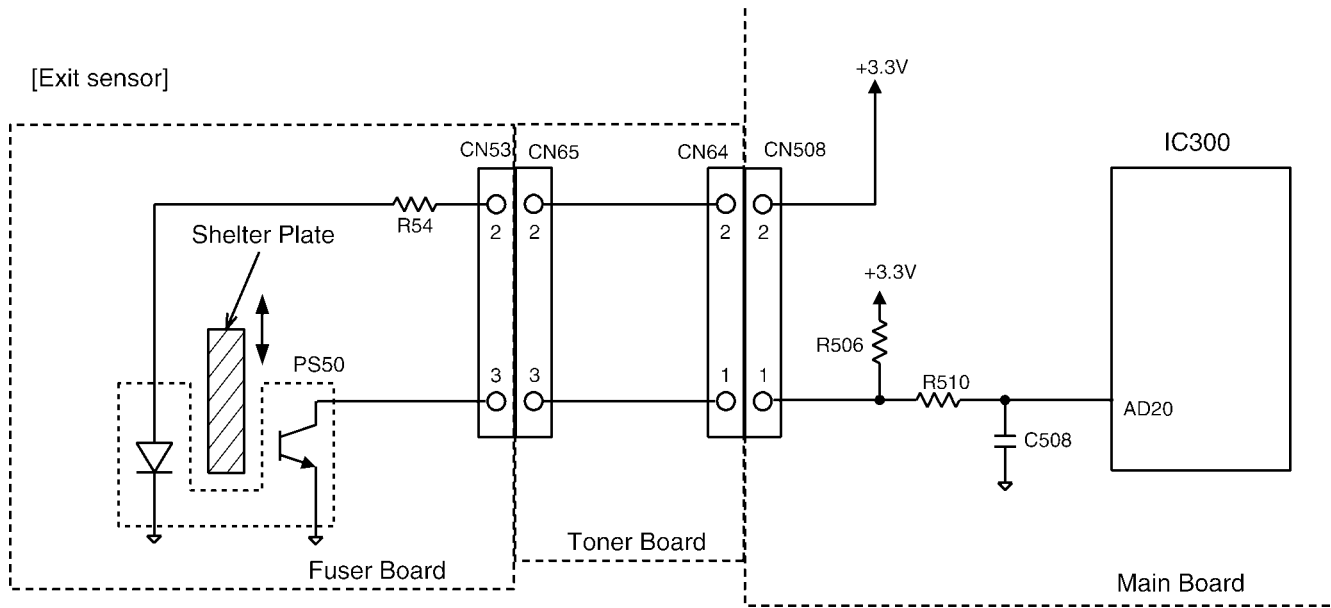

	Signal (IC300-AD20pin)
A paper exists	Low level
No papers	High level

6.10.4. Home Sensor

This sensor detects whether the carriage is at its home position or not.

When the carriage is at its home position, a shelter plate closes the sensor light.

So the photo-transistor turns off and the input signal of IC300-V23pin becomes high level.

When the carriage is not at its home position, a shelter plate lets the sensor light pass.

So the photo-transistor turns on and the input signal of IC300-V23pin becomes low level.

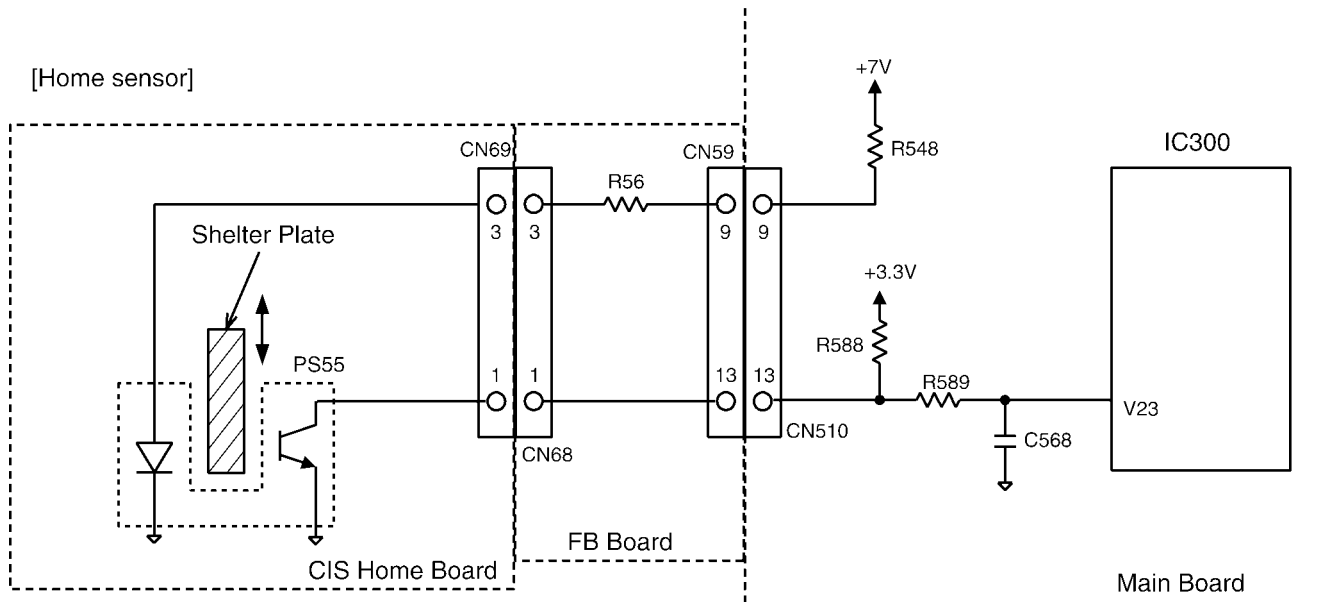

	Photo-transistor	Signal (IC300-V23pin)
A carriage is at home	OFF	High level
A carriage is not at home	ON	Low level

6.10.5. Read Position Sensor (KX-MB2010 ONLY)

This sensor detects the front edge of the document.

When the front edge of the document is detected, the shelter plate closes the sensor light.

So the photo-transistor turns off and the input signal of IC300-AD22pin becomes high level.

When the front edge of the document is not detected, the shelter plate lets the sensor light pass.

So the photo-transistor turns on and the input signal of IC300-AD22pin becomes low level.

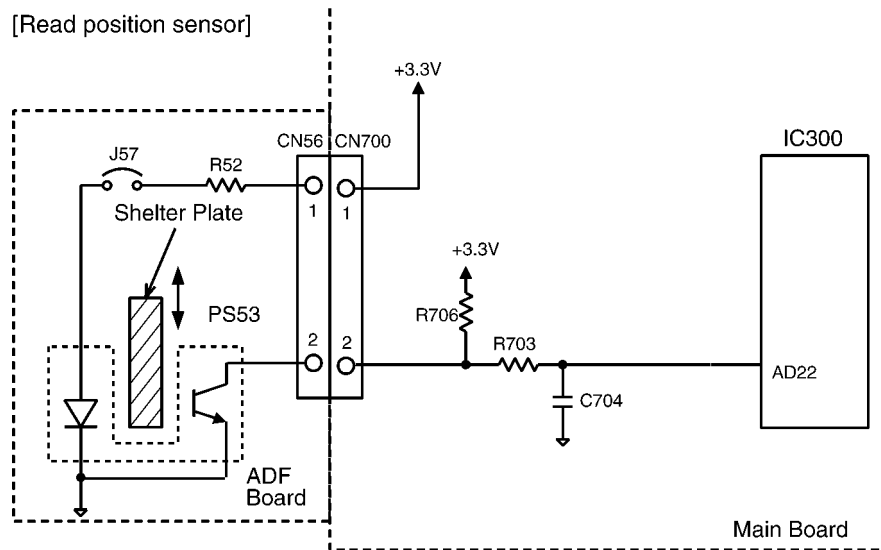

	Photo-transistor	Signal (IC300-AD22pin)
A document exists	OFF	High level
No document	ON	Low level

6.10.6. Registration & Manual Paper Sensor

This sensor detects whether the recording paper is at the sensor position.
 When the recording paper is detected, the shelter plate lets the sensor light pass.
 So the photo-transistor turns on, and input signal of IC300-AF20pin becomes low level.
 When the recording paper is not detected, the shelter plate closes the sensor light.
 So the photo-transistor turns off, and input signal of IC300-AF20pin becomes high level.

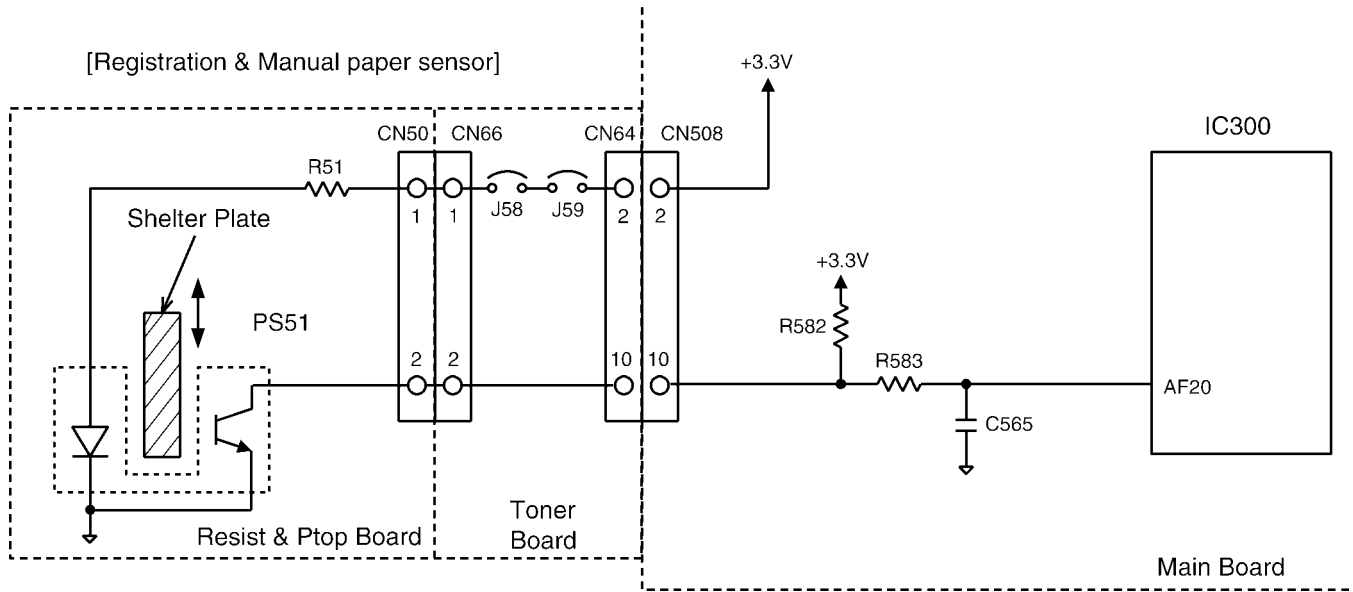

	Photo-transistor	Signal (IC300-AF20pin)
Paper exists	ON	Low level
No paper	OFF	High level

6.10.7. Print Timing Sensor

This sensor detects whether the recording paper is at the printing position.
 When the recording paper is detected, the shelter plate lets the sensor light pass.
 So the photo-transistor turns on, and input signal of IC300-W26pin becomes low level.
 When the recording paper is not detected, the shelter plate closes the sensor light.
 So the photo-transistor turns off, and input signal of IC300-W26pin becomes high level.

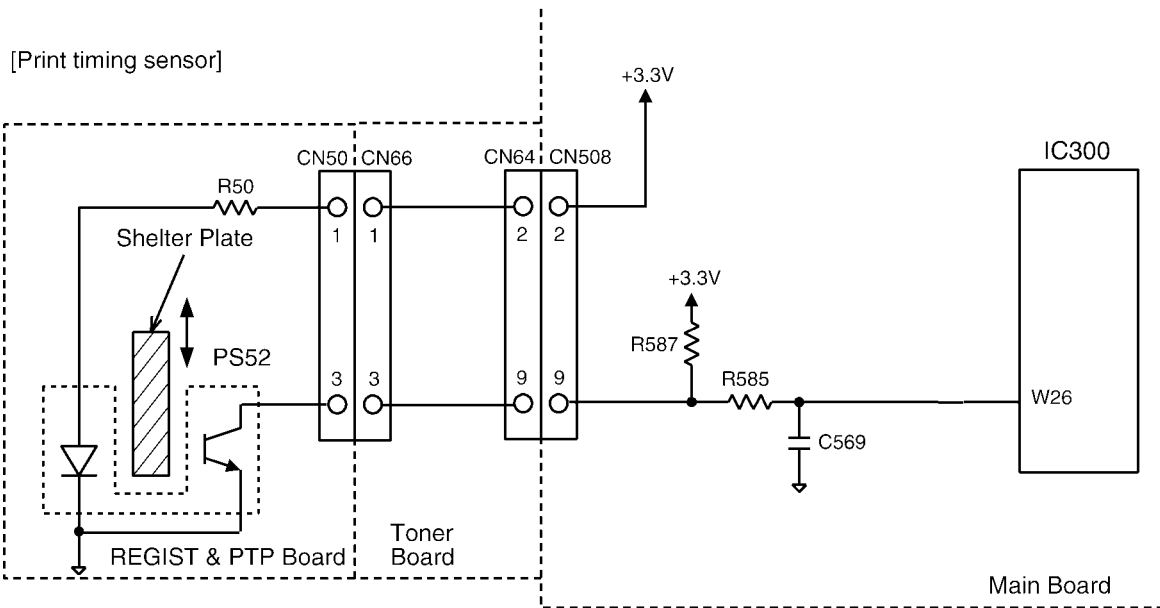

	Photo-transistor	Signal (IC300-W26pin)
Paper exists	ON	Low level
No paper	OFF	High level

6.10.8. Document Sensor (KX-MB2010 ONLY)

This sensor detects whether a document is set in ADF or not.

When a document is set in ADF, the shelter plate closes the sensor light.

So the photo-transistor turns off, and input signal of IC300-AF23pin becomes high level.

When a document is not set in ADF, the shelter plate lets the sensor light pass.

So the photo-transistor turns on, and input signal of IC300-AF23pin becomes low level.

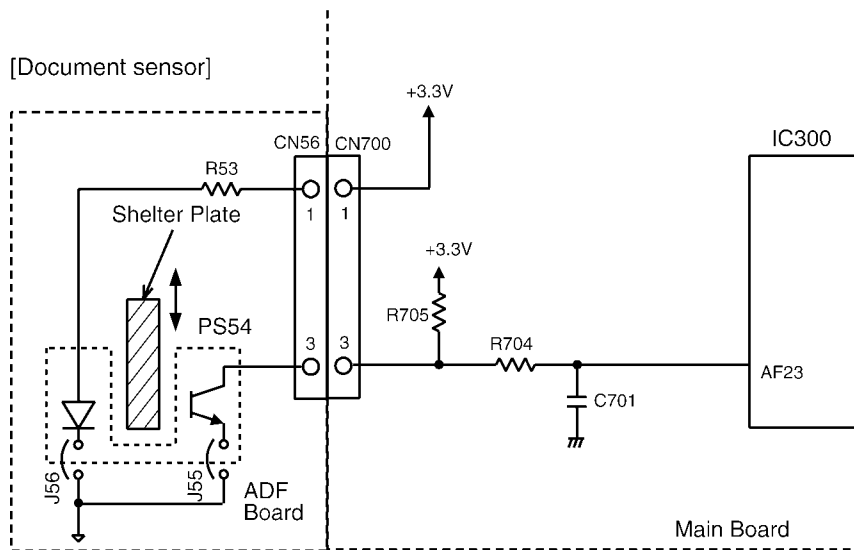

	Photo-transistor	Signal (IC300-AF23)
document exists	OFF	High level
No document	ON	Low level

6.10.9. Top Cover Sensor

The Switches detect whether the top cover is open or closed.

When the top cover is closed, the switches turn ON, and the input signal of IC300-W25pin becomes a low level.

When the top cover is open, the switches turns OFF, and the input signal of IC300-W25pin becomes a high level.

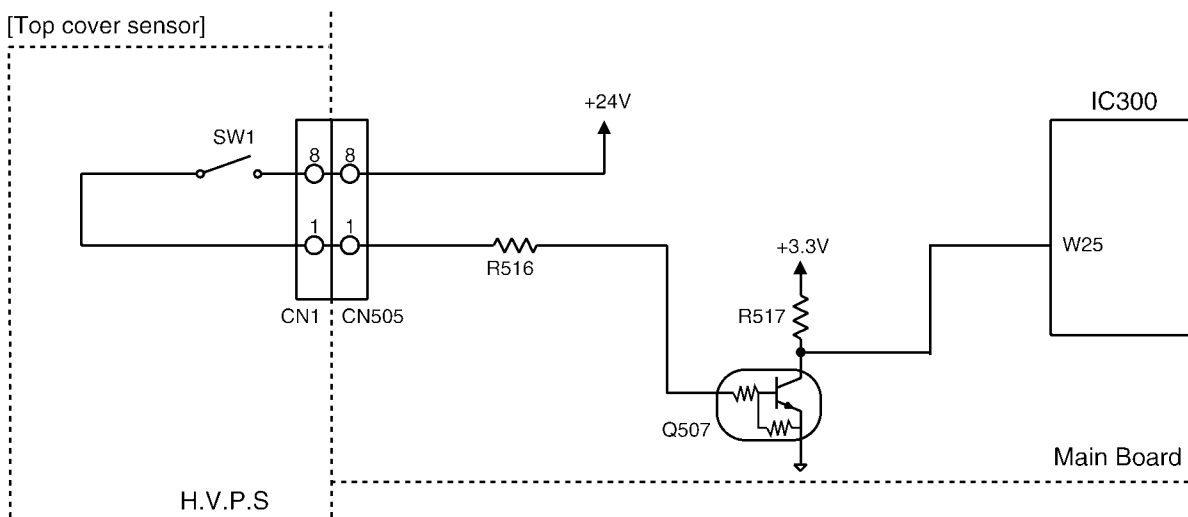

	Switch	Signal (IC300-W25pin)
Open	OFF	High level
Close	ON	Low level

6.10.10. Toner Sensor... “Toner Empty”, “Toner Low”, “Change Drum”

The Sensor detects whether or not the Drum cartridge and the toner are present.

When there is not Drum cartridge, Magnetic Field Sensor IC (IC51) turns off, and the input signal of IC300-AE22pin (Main Board) becomes a High level over 9s. When the Drum cartridge is set, Magnetic Field Sensor IC (IC51) turns ON/OFF. If the time of IC300-AE22pin's Low level is under 600ms, there is enough toner in Drum cartridge, if not, toner is near empty.

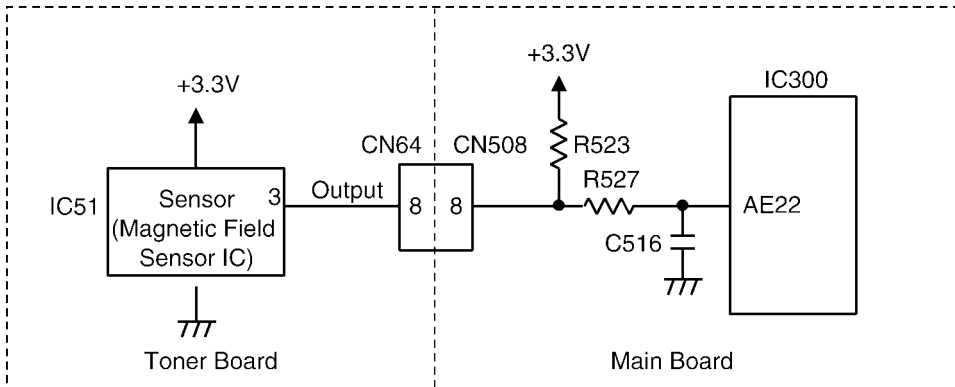

1. Toner Full

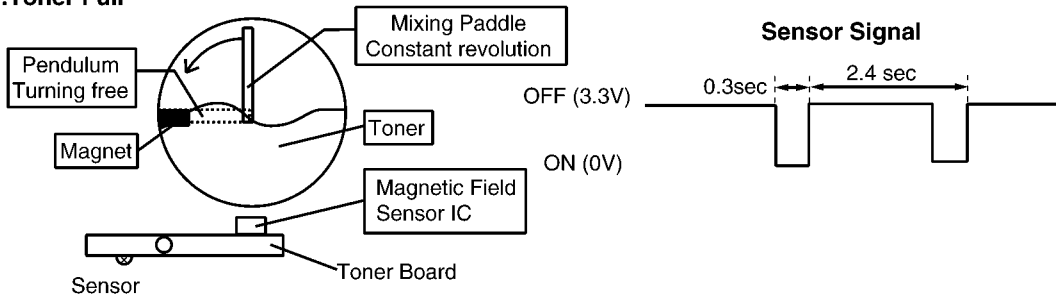

2. Toner Low

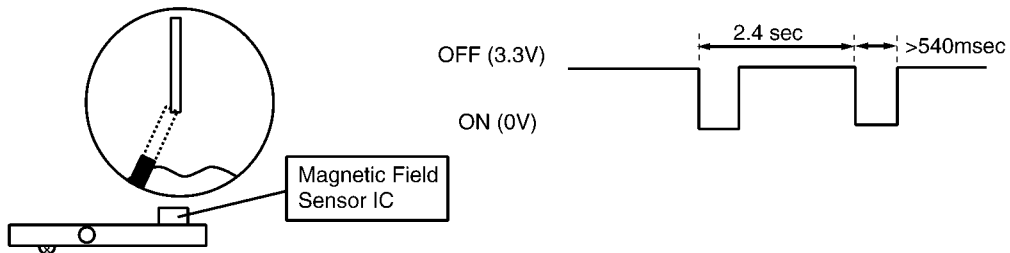

3. In case the Mixing Paddle does not rotate

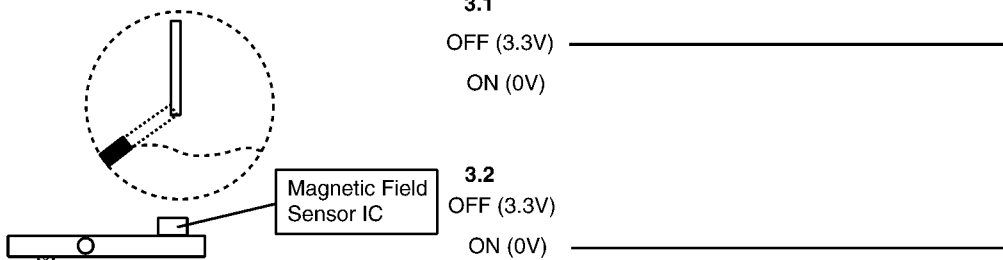

Toner Sensor

The rest of toner is detected by the move speed of the magnet put on the pendulum of Mixing Paddle. The pendulum is pushed up by the Mixing Paddle, then it falls down by its own weight. The rotation speed of paddle is set slower than the one of pendulum which falls down by its own weight. When the toner is still left, the pendulum falls and stops on the toner, then pushed by the paddle, it starts to rotate. When no toner is left, the pendulum falls to the bottom. Consequently the contact time between the magnet and Magnetic Field sensor IC becomes short when toner is left and long with no toner.

State	Display	Signal (IC300-AE22pin)
Toner Set (full)	-	level = about 0.3s
Near Empty Toner	TONER LOW	Low level>540ms
Mixing Paddle does not rotate (“CHANGE DRUM”)	CHANGE DRUM	High level fix or Low level fix

6.10.10.1. Toner Detection Flow

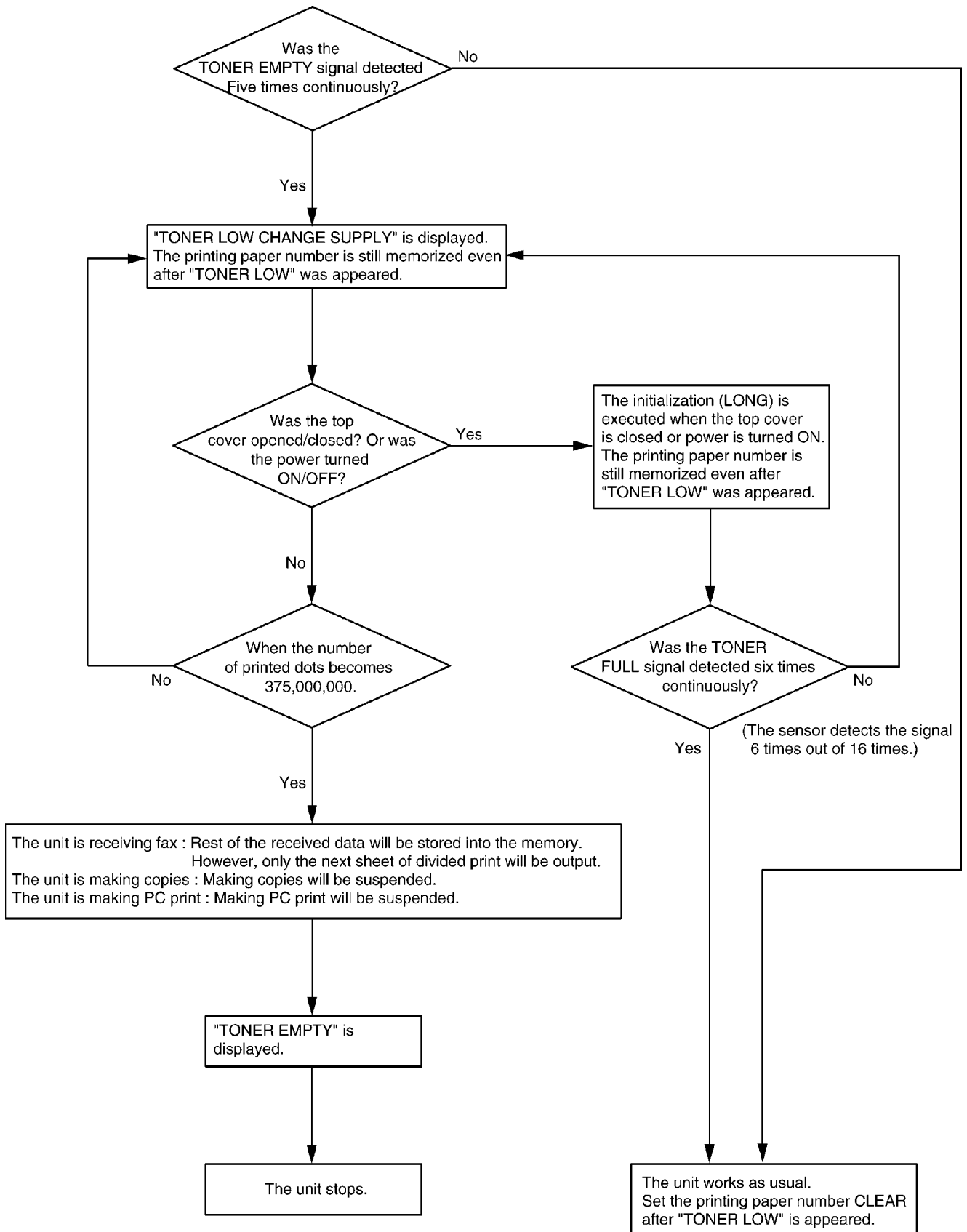

CAUTION:

1. Toner low can be judged by continuous 5-times TONER LOW signal at only printing.
(It is not executed at.)
2. Toner full can be judged by continuous 6-times TONER FULL signal at initialization.
(It is not executed at printing.)
3. In the ordinal operation, "CHANGE DRUM" is displayed when TONER EMPTY sensor does not generate a signal for 7.4 seconds.

6.10.10.2. Drum Detection

Detection Flowchart

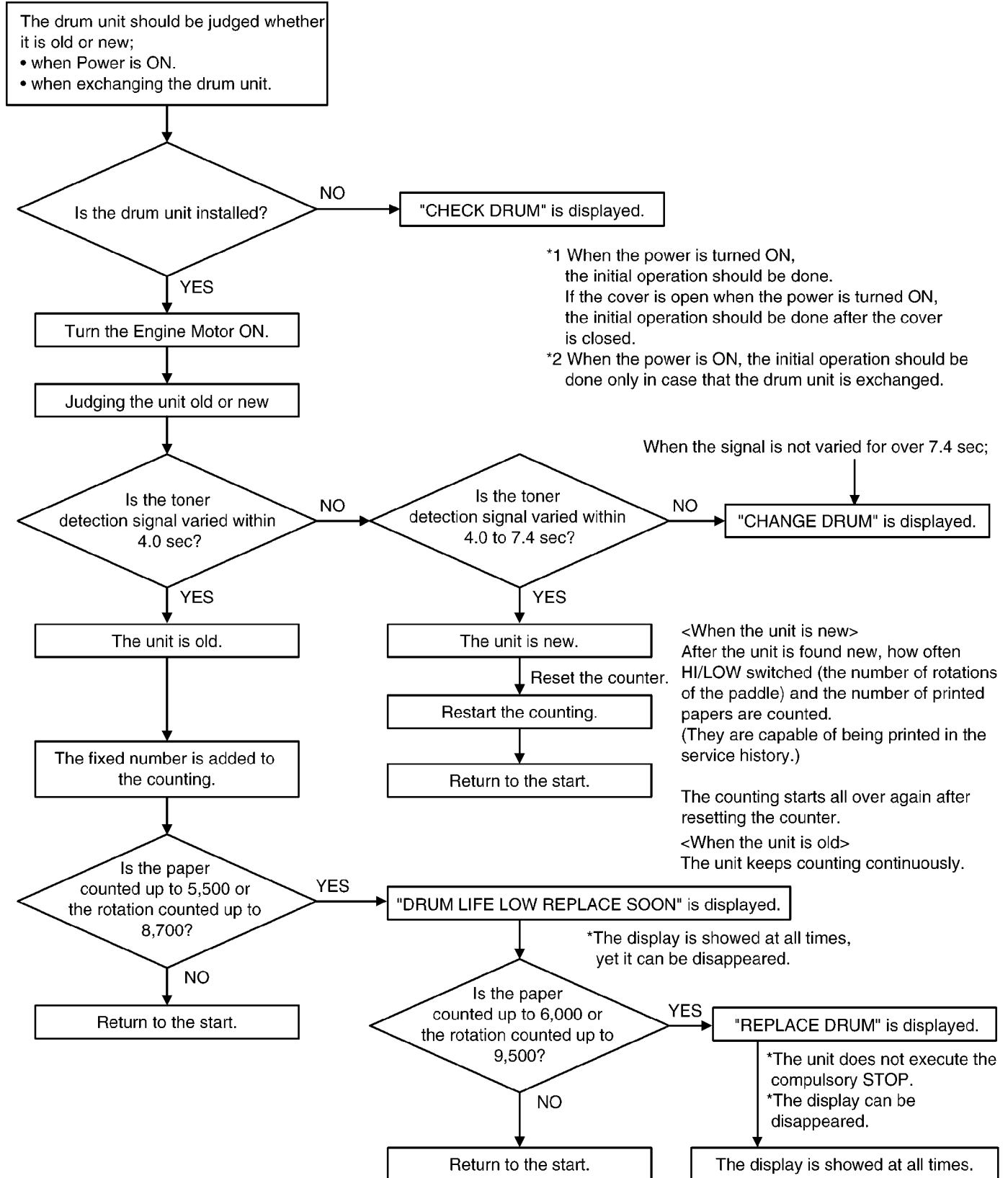

6.11. Operation Board Section

The unit consists of a LCD (Liquid crystal display), KEYS and LEDs (light-emitting diodes). They are controlled by the Gate Array (IC1) on Operation board and IC300 on Main board.

The key matrix table is shown below.

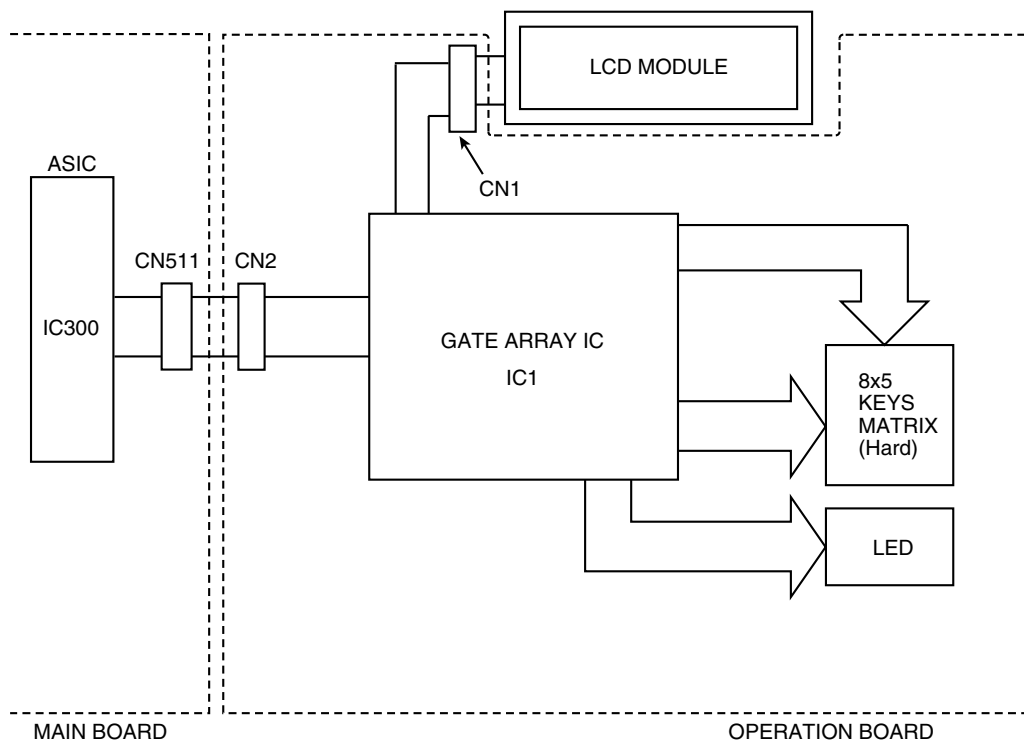

1. Key Matrix

a. Hard Scan

	KIN0	KIN1	KIN2	KIN3	KIN4	KIN5	KIN6	KIN7
KSL0	8	7	↓	9		S2	S4	RESOLUTION
KSL1	0	*	→	#				CONTRAST
KSL2	2	1	MENU	3		S1		COLLATE
KSL3	STOP	←	↑	START	N in 1	COPY	S3	ZOOM
KSL4 (LED7)	5	4	SET	6		SCAN	AUTO ANSWER	

*LED7 should be set to KSL4. "8 x 5" key matrix is executed by hardware scanning.

2. LED

- AUTO ANSWER LED ON/OFF port---LED2 (IC1-36pin)
- COPY MODE LED ON/OFF port---XLED12 (IC1-15pin)
- SCAN MODE LED ON/OFF port---XLED11 (IC1-16pin)

6.12. LCD Section

The Gate Array (IC1) works only for writing the ASCII code from the data bus (D4~D7). V0 is supplied for the LCD drive. R6 and R7 are density control resistors.

Consequently, in this unit, the timing (positive clock) is generated by the LCD interface circuitry in the gate array (IC1).

Circuit Diagram

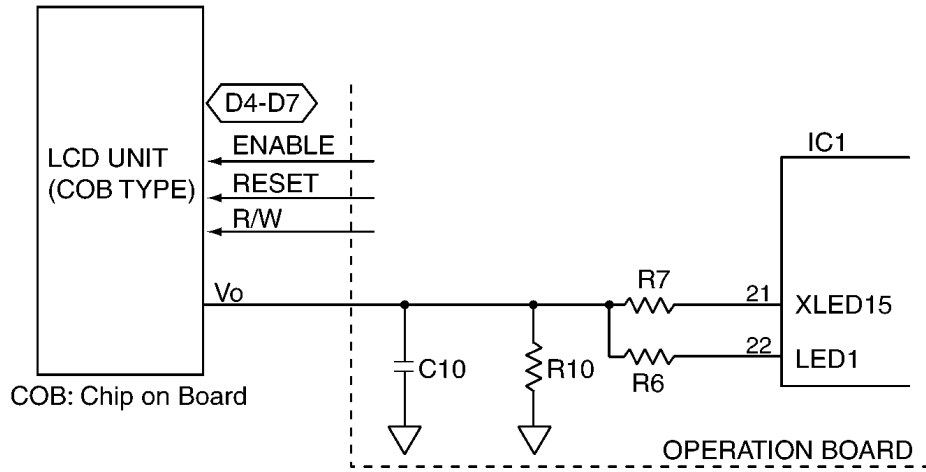

Timing Chart

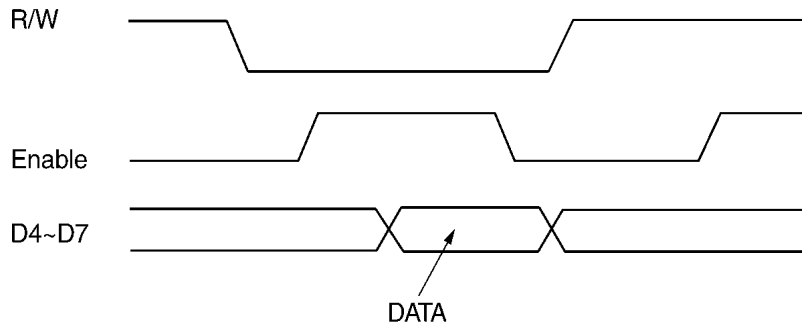

6.13. HVPS (High Voltage Power Supply) Section

6.13.1. HVPS Specification

	Charge (CHG)	Grid	Developing DC	Developing AC	Transfer (TRA) -	Transfer (TRA) +
Output Characteristics	Constant current	Constant voltage	Constant voltage	Constant voltage	Constant current (Variable)	Constant voltage
Nominal Output Voltage	4.35KV	475±10V	230V±15V (50~300V) PWM20% 300MΩ/220pF	330V±15Vp-p 34KHz	100MΩ (-1.48KV)	785V±100V
Nominal Output Current	200±15μA (19.4MΩ)	200μA	0.73μA	-----	-14.8μA±1μA (0μA~25μA) PWM 35%	1000MΩ (0.8μA)
Load Range	18.1MΩ~20.6MΩ	-----	100MΩ~2000MΩ	-----	33.8MΩ~284MΩ	10MΩ~1000MΩ
Constant Current Range	4.1~4.6KV	-----	-----	-----	-0.5KV ~ -4.2KV	-----

As for the developing voltage, the DC voltage and AC voltage are overlapped and output from an output terminal. There is one terminal for transcription output and + and - are switched to be output.

H.V.P.S.(High Voltage Power Supply) Circuit Diagram

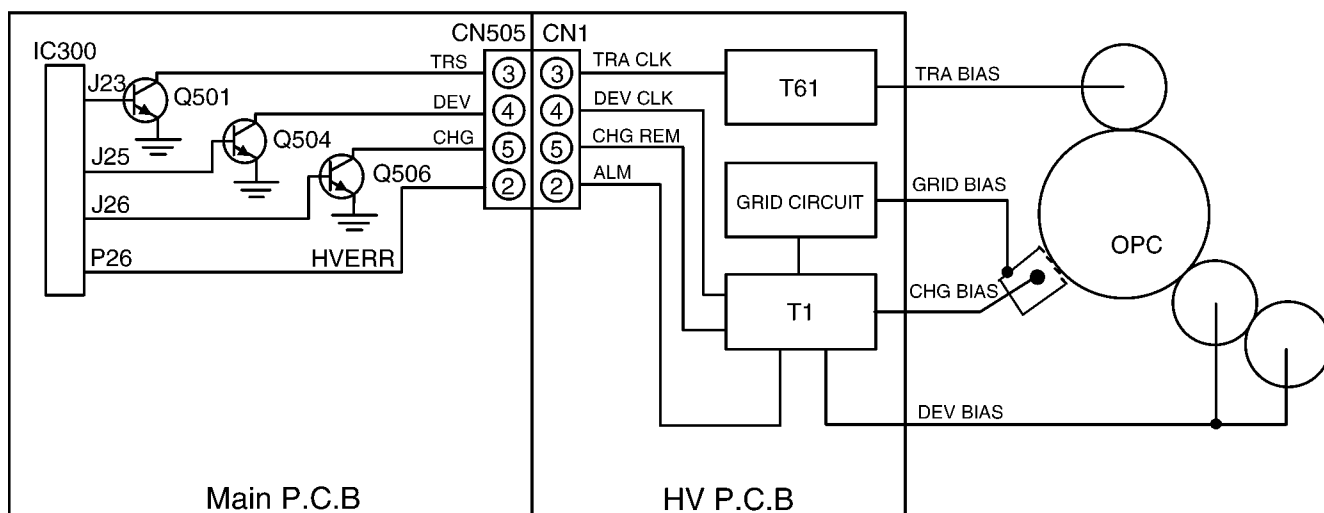

6.13.2. CHG-BIAS (Charge BIAS)/GRID/ UNIT

When IC300 turns on the transistor Q506, CHG REM becomes "L", and Charge BIAS (200μA) is output from CHG OUTPUT. GRID BIAS is generated by the current flowing in the GRID circuit via charge wire and GRID.

6.13.3. DEV DC BIAS UNIT

When CHG REM is "L", 5.425kHz PWM (Pulse Width Modulation) is input from IC300 to DEV CLK through Q504, developing voltage corresponding to the DUTY of PWM signal is output from DEV OUTPUT. Also DUTY is adjusted by the utilization of the developing unit and environmental temperature.

Transfer Current Variation by PWM Input

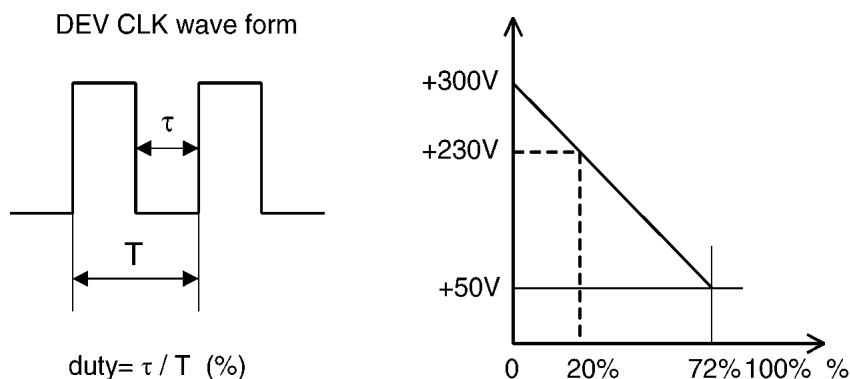

6.13.4. DEV AC BIAS UNIT

330 Vp-p 34 kHz wave of developing AC voltage is output from DEV OUTPUT. This voltage is overlapped with developing DC voltage and output as AC voltage that includes the development DC voltage.

6.13.5. TRA (+) BIAS (Transfer (+) BIAS)/TRA (-) BIAS (Transfer (-) BIAS) UNIT

When CHG REM is "L" and TRA CLK is "open", Charge BIAS (200 μ A) is output from CHG OUTPUT, and at the same time Transfer (+) BIAS (785V) is output from TRA OUTPUT. When 5.086kHz PWM (Pulse Width Modulation) signal is input to TRA CLK through transistor Q501, Transfer (-) CURRENT BIAS corresponding to PWM signal is output from TRA OUTPUT.

Transcription current variation corresponding to PWM input

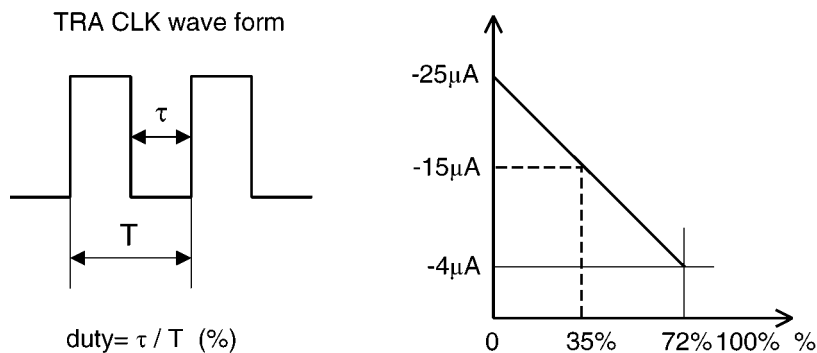

6.14. Heat Lamp Control Circuit

The temperature of the fixing part of the Fuser Unit is converted to a voltage by THERMISTOR and input to IC300-D19pin. The heat lamp is turned on/off by the HTRCTL signal (IC300-AD19pin) through the photo triac (PC2) and the triac (SCR51). And two thermostats are set on the AC line as the safety devices.

Overheat protection circuit is provided in order to prevent the Fuser unit from overheating when CPU cannot control Fuser by some problem.

IC504 compares Thermistor voltage and fixed voltage, which is determined by R581 and R584.

If Thermistor voltage becomes lower than this fixed voltage (this voltage corresponds to about 240 degree C), output of IC504 become "H", then Q528 turns ON, and Q500 is turned Off.

As the result, no current is supplied to Fuser lamp.

Circuit Diagram

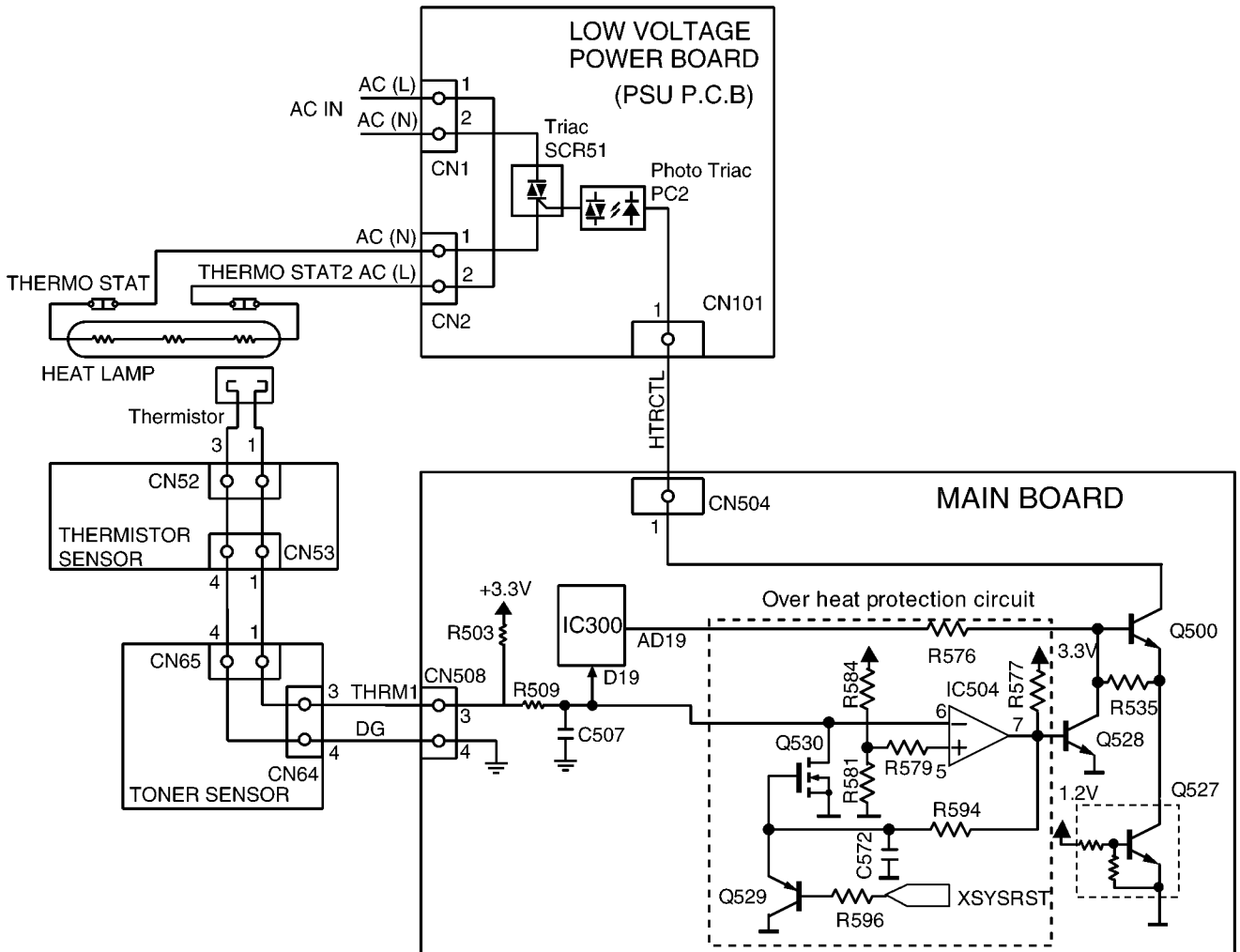

1. Control at Printing

- After the printing signal is received, turn ON the heater.
- After that, turn ON the motor at the Primary Stable Temperature (170°C).
- After that, control at the Secondary Stable temperature (195°C), and feed papers.

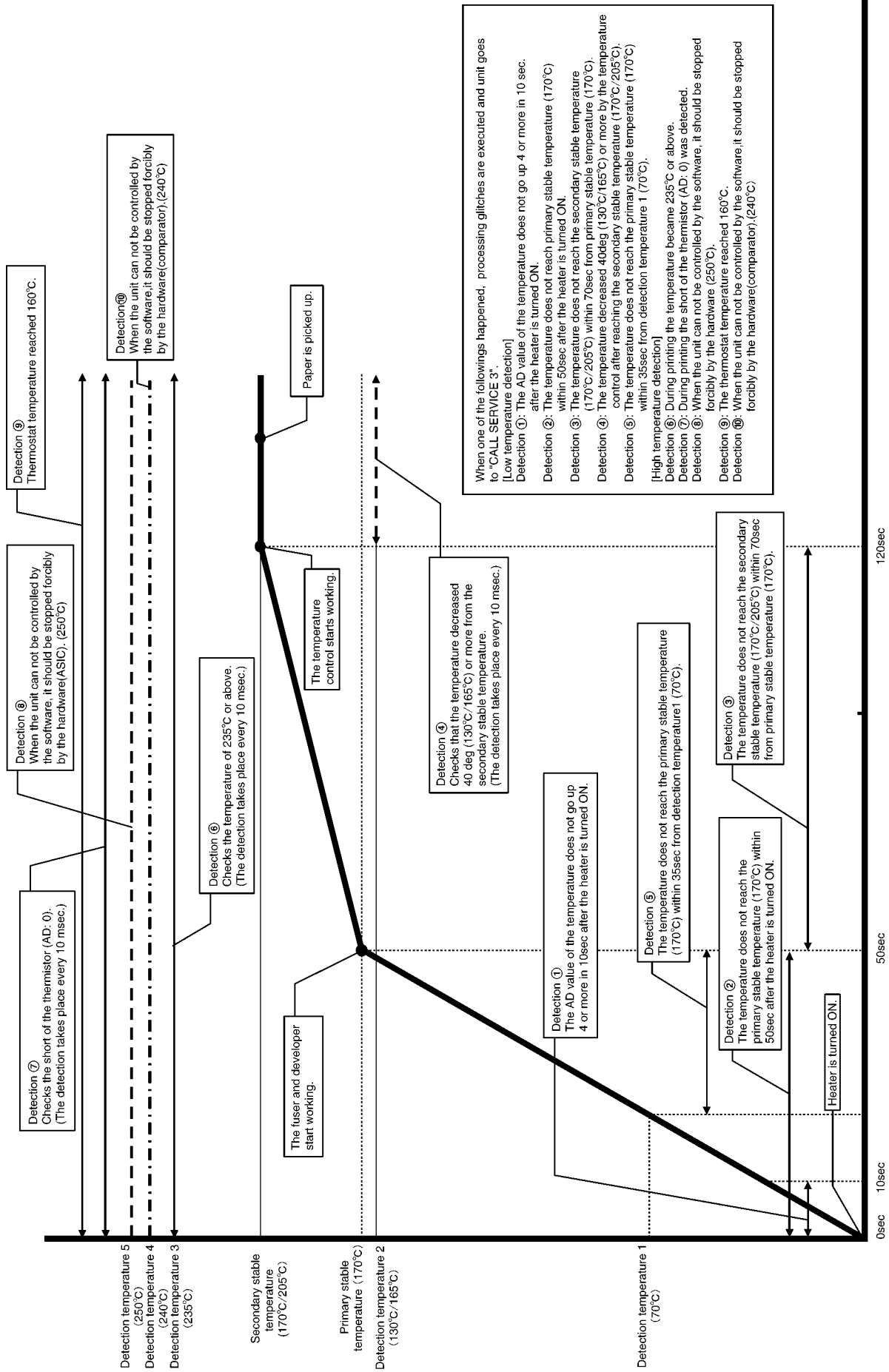

When one of the followings happened, processing glitches are executed and unit goes to "CALL SERVICE 3".

Detection 1: The AD value of the temperature does not go up 4 or more in 10 sec. after the heater is turned ON.

Detection 2: The temperature does not reach primary stable temperature (170°C) within 50sec after the heater is turned ON.

Detection 3: The temperature does not reach the secondary stable temperature (170°C/205°C) within 70sec from primary stable temperature (170°C).

Detection 4: The temperature decreased 40deg (130°C/165°C) or more by the temperature control after reaching the secondary stable temperature (170°C/205°C).

Detection 5: The temperature does not reach the primary stable temperature (170°C) within 35sec from detection temperature 1 (70°C).

[High temperature detection]

Detection 6: During printing the temperature became 235°C or above.

Detection 7: During printing the short of the thermistor (AD: 0) was detected.

Detection 8: When the unit can not be controlled by the software, it should be stopped forcibly by the hardware (250°C).

Detection 9: The thermostat temperature reached 160°C.

Detection 10: When the unit can not be controlled by the software, it should be stopped forcibly by the hardware (comparator). (240°C)

2. Safety Protection

- a. 2 thermostats are provided with the unit, and the heater circuit is shut down when their surface temperatures became over 160 °C.
- b. The heater control circuit of IC300 has the built-in function that the hardware turns off the heater control automatically if the software does not keep turning ON the heater every a fixed time.
- c. When the temperature became over 250 °C, the heater control circuit of IC300 is turned off forcedly and system reset will be executed.

3. The correspondence readings between temperature measured by fixing thermistor and HEX readings

You can read the AD value of heater temperature in service mode.

Push the keys [MENU]-[#]-[9][0][0][0]-[*]-[8][1][5].

LCD indicates as below.

```

D S C * R E * T * 3 F * D F * *
* U T * * H * * * * * * * * * *
    
```

↓
These 2 digits mean the AD value(HEX)
according to the table below.

Heat Roller Temperature - Voltage

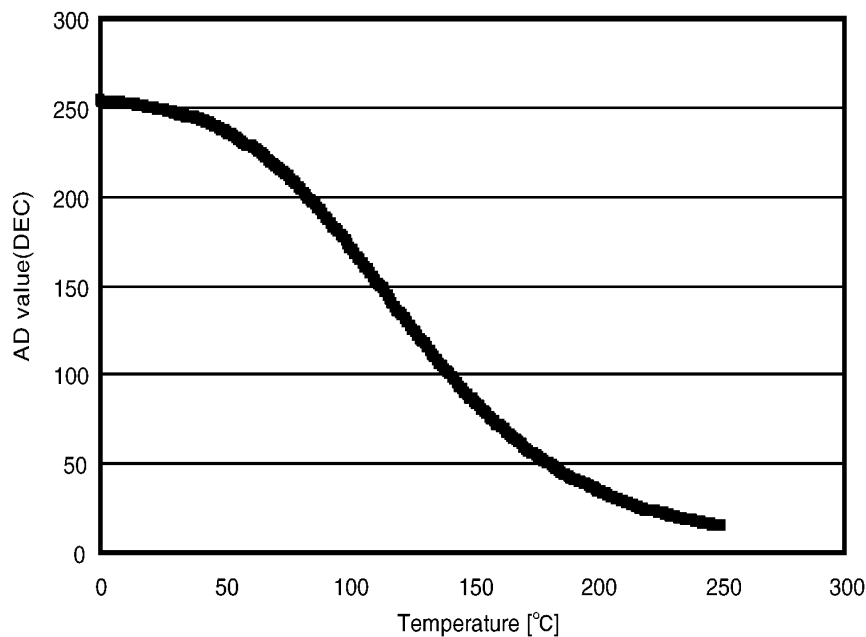

Temperature [°C]	AD value		Temperature [°C]	AD value		Temperature [°C]	AD value		Temperature [°C]	AD value		Temperature [°C]	AD value	
	DEC	HEX		DEC	HEX		DEC	HEX		DEC	HEX		DEC	HEX
0	254	FE	51	236	EC	101	171	AB	151	84	54	201	34	22
1	253	FD	52	235	EB	102	170	AA	152	83	53	202	34	22
2	253	FD	53	235	EB	103	168	A8	153	82	52	203	33	21
3	253	FD	54	234	EA	104	166	A6	154	80	50	204	33	21
4	253	FD	55	233	E9	105	164	A4	155	79	4F	205	32	20
5	253	FD	56	232	E8	106	162	A2	156	78	4E	206	31	1F
6	253	FD	57	231	E7	107	160	A0	157	76	4C	207	31	1F
7	253	FD	58	230	E6	108	159	9F	158	75	4B	208	30	1E
8	253	FD	59	229	E5	109	157	9D	159	74	4A	209	30	1E
9	252	FC	60	229	E5	110	155	9B	160	72	48	210	29	1D
10	252	FC	61	228	E4	111	153	99	161	71	47	211	29	1D
11	252	FC	62	227	E3	112	151	97	162	70	46	212	28	1C
12	252	FC	63	226	E2	113	149	95	163	69	45	213	28	1C
13	252	FC	64	225	E1	114	148	94	164	67	43	214	27	1B
14	252	FC	65	224	E0	115	146	92	165	66	42	215	27	1B
15	251	FB	66	223	DF	116	144	90	166	65	41	216	26	1A
16	251	FB	67	222	DE	117	142	8E	167	64	40	217	26	1A
17	251	FB	68	220	DC	118	140	8C	168	63	3F	218	25	19
18	251	FB	69	219	DB	119	138	8A	169	62	3E	219	25	19
19	250	FA	70	218	DA	120	136	88	170	61	3D	220	24	18

Temperature [°C]	AD value		Temperature [°C]	AD value		Temperature [°C]	AD value		Temperature [°C]	AD value		Temperature [°C]	AD value	
	DEC	HEX		DEC	HEX		DEC	HEX		DEC	HEX		DEC	HEX
20	250	FA	71	217	D9	121	135	87	171	59	3B	221	24	18
21	250	FA	72	216	D8	122	133	85	172	58	3A	222	24	18
22	250	FA	73	215	D7	123	131	83	173	57	39	223	23	17
23	249	F9	74	213	D5	124	129	81	174	56	38	224	23	17
24	249	F9	75	212	D4	125	127	7F	175	55	37	225	22	16
25	249	F9	76	211	D3	126	125	7D	176	54	36	226	22	16
26	249	F9	77	209	D1	127	124	7C	177	53	35	227	22	16
27	248	F8	78	208	D0	128	122	7A	178	52	34	228	21	15
28	248	F8	79	207	CF	129	120	78	179	51	33	229	21	15
29	248	F8	80	205	CD	130	118	76	180	50	32	230	20	14
30	247	F7	81	204	CC	131	117	75	181	50	32	231	20	14
31	247	F7	82	202	CA	132	115	73	182	49	31	232	20	14
32	246	F6	83	201	C9	133	113	71	183	48	30	233	19	13
33	246	F6	84	199	C7	134	111	6F	184	47	2F	234	19	13
34	246	F6	85	198	C6	135	110	6E	185	46	2E	235	19	13
35	245	F5	86	196	C4	136	108	6C	186	45	2D	236	18	12
36	245	F5	87	195	C3	137	106	6A	187	44	2C	237	18	12
37	244	F4	88	193	C1	138	105	69	188	44	2C	238	18	12
38	244	F4	89	192	C0	139	103	67	189	43	2B	239	18	12
39	243	F3	90	190	BE	140	101	65	190	42	2A	240	17	11
40	243	F3	91	188	BC	141	100	64	191	41	29	241	17	11
41	242	F2	92	187	BB	142	98	62	192	41	29	242	17	11
42	242	F2	93	185	B9	143	97	61	193	40	28	243	16	10
43	241	F1	94	183	B7	144	95	5F	194	39	27	244	16	10
44	241	F1	95	182	B6	145	93	5D	195	38	26	245	16	10
45	240	F0	96	180	B4	146	92	5C	196	38	26	246	16	10
46	239	EF	97	178	B2	147	90	5A	197	37	25	247	15	0F
47	239	EF	98	177	B1	148	89	59	198	36	24	248	15	0F
48	238	EE	99	175	AF	149	87	57	199	36	24	249	15	0F
49	237	ED	100	173	AD	150	86	56	200	35	23	250	15	0F
50	237	ED												

Note: The value is displayed on LCD at **Test Functions** (P.80) [#815].

4. The correspondence readings between room temperature measured by thermistor and HEX readings
 You can read the AD value of room temperature in service mode.
 Push the keys [MENU]-[#]-[9][0][0][0]-[*]-[8][1][5].

LCD indicates as below.

```
D S C * R E * T * 3 F * D F * *
* U T * * H * * * * * * * * * *
```

These 2 digits mean the AD value(HEX)
 according to the table below.

Temperature [°C]	AD value		Temperature [°C]	AD value		Temperature [°C]	AD value		Temperature [°C]	AD value		Temperature [°C]	AD value	
	DEC	HEX		DEC	HEX		DEC	HEX		DEC	HEX		DEC	HEX
-40	230	E6	-5	164	A4	30	80	50	65	32	20	100	13	0D
-39	229	E5	-4	161	A1	31	78	4E	66	31	1F	101	12	0C
-38	228	E4	-3	159	9F	32	76	4C	67	30	1E	102	12	0C
-37	226	E2	-2	156	9C	33	74	4A	68	29	1D	103	12	0C
-36	225	E1	-1	154	9A	34	72	48	69	28	1C	104	11	0B
-35	224	E0	0	151	97	35	71	47	70	28	1C	105	11	0B
-34	222	DE	1	149	95	36	69	45	71	27	1B	106	11	0B
-33	221	DD	2	146	92	37	67	43	72	26	1A	107	11	0B
-32	219	DB	3	144	90	38	65	41	73	26	1A	108	10	0A
-31	218	DA	4	141	8D	39	64	40	74	25	19	109	10	0A
-30	216	D8	5	139	8B	40	62	3E	75	24	18	110	10	0A
-29	215	D7	6	136	88	41	60	3C	76	24	18	111	10	0A
-28	213	D5	7	134	86	42	59	3B	77	23	17	112	9	09

Temperature [°C]	AD value		Temperature [°C]	AD value		Temperature [°C]	AD value		Temperature [°C]	AD value		Temperature [°C]	AD value	
	DEC	HEX		DEC	HEX		DEC	HEX		DEC	HEX		DEC	HEX
-27	211	D3	8	131	83	43	57	39	78	22	16	113	9	09
-26	209	D1	9	129	81	44	56	38	79	22	16	114	9	09
-25	208	D0	10	126	7E	45	54	36	80	21	15	115	9	09
-24	206	CE	11	124	7C	46	53	35	81	21	15	116	9	09
-23	204	CC	12	121	79	47	51	33	82	20	14	117	8	08
-22	202	CA	13	119	77	48	50	32	83	20	14	118	8	08
-21	200	C8	14	116	74	49	49	31	84	19	13	119	8	08
-20	198	C6	15	114	72	50	47	2F	85	19	13	120	8	08
-19	196	C4	16	111	6F	51	46	2E	86	18	12	121	8	08
-18	194	C2	17	109	6D	52	45	2D	87	18	12	122	7	07
-17	192	C0	18	107	6B	53	44	2C	88	17	11	123	7	07
-16	189	BD	19	104	68	54	43	2B	89	17	11	124	7	07
-15	187	BB	20	102	66	55	41	29	90	16	10	125	7	07
-14	185	B9	21	100	64	56	40	28	91	16	10			
-13	183	B7	22	97	61	57	39	27	92	16	10			
-12	180	B4	23	95	5F	58	38	26	93	15	0F			
-11	178	B2	24	93	5D	59	37	25	94	15	0F			
-10	176	B0	25	91	5B	60	36	24	95	14	0E			
-9	173	AD	26	88	58	61	35	23	96	14	0E			
-8	171	AB	27	86	56	62	34	22	97	14	0E			
-7	169	A9	28	84	54	63	33	21	98	13	0D			
-6	166	A6	29	82	52	64	33	21	99	13	0D			

6.15. Main Board Section

3.3V and 1.2V Power Supply descriptions

- IC800 is 2ch-output PWM type DC-DC converter controller, which make up step down type DC-DC converter circuit with Pch power MOSFET Q802 and Q803, coil of L800 and L801, schottky diode of D800 and D803, capacitor of C800, C802 and C817, C818.

The oscillation frequency in operation of this DC-DC converter is set to about 410kHz.

- R807,R809,R808,C814,R805,Q800,Q801 are UVLO (Under Voltage Lock Out) circuit. Q801 turns on when the in-out voltage is about 16V or less and CS terminal becomes low so that IC800's operation is stopped.
- Q804,Q806,D805 and Q805,Q807,D806 are Clamp circuit which clamps VGS(Gate Voltage of Q802 and Q803) not to be a over voltage.
- D801 and D804 are Zenner diodes which control not to be a over voltage at 3.3V and 1.2V output when ICs including IC800 break down.

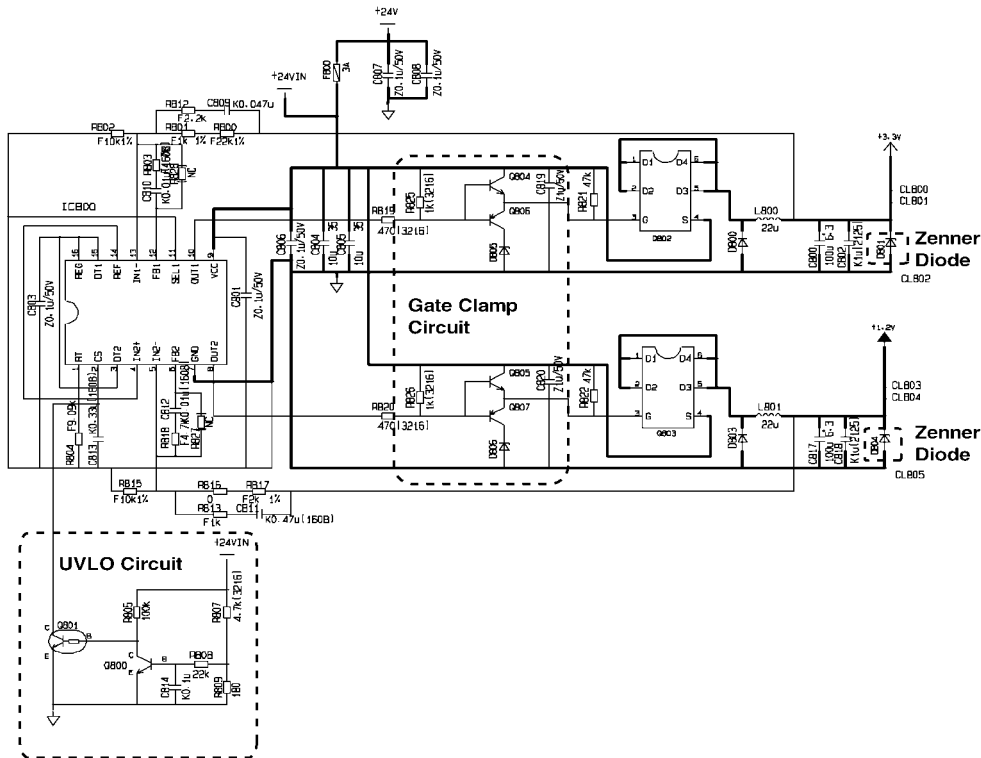

5V Power Supply descriptions

- IC501 is turned ON when 3.3V power supply is booted , 5V is generated from 7V-input.

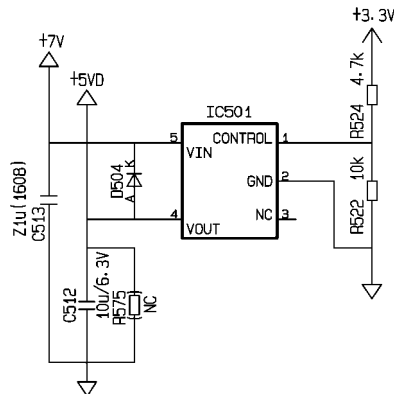

Power Supply

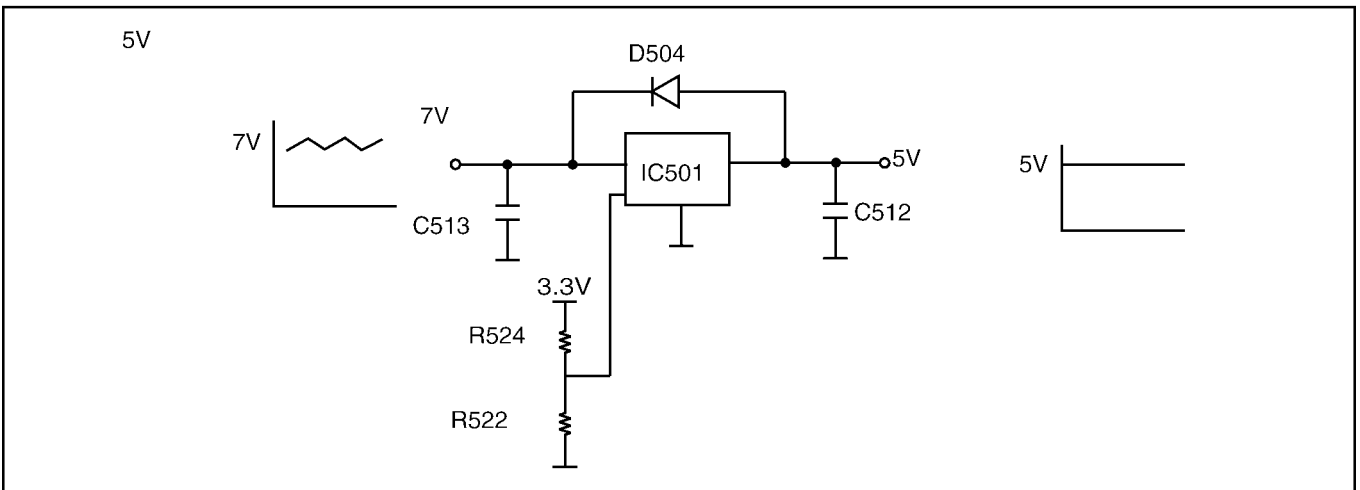
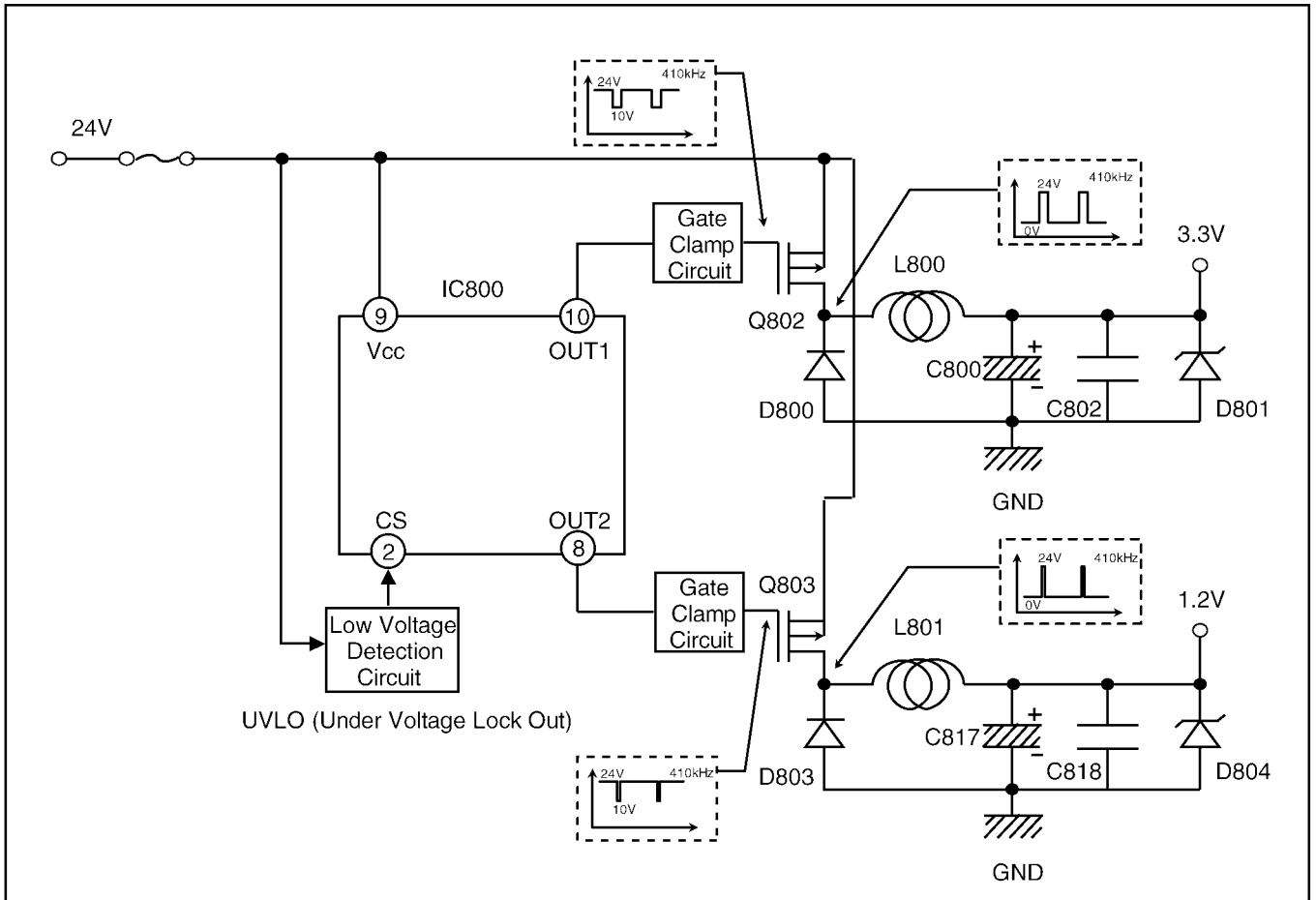

wave form

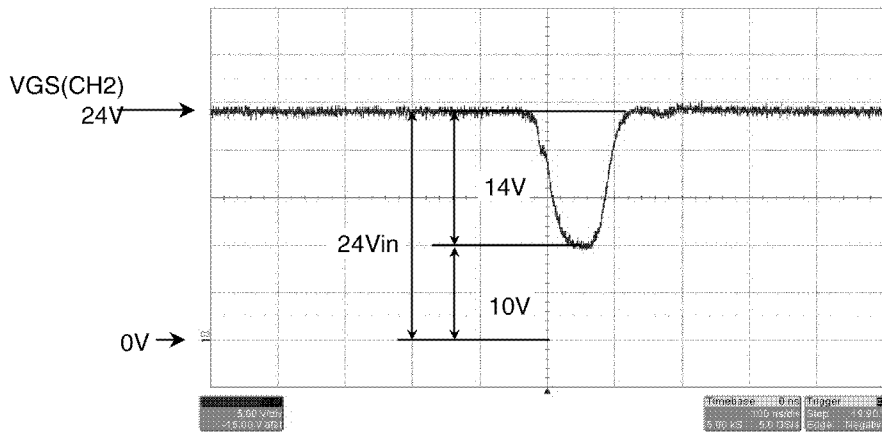
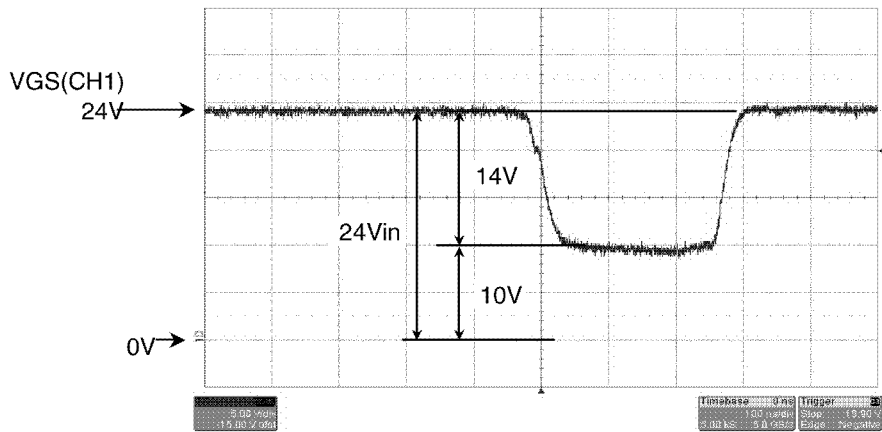
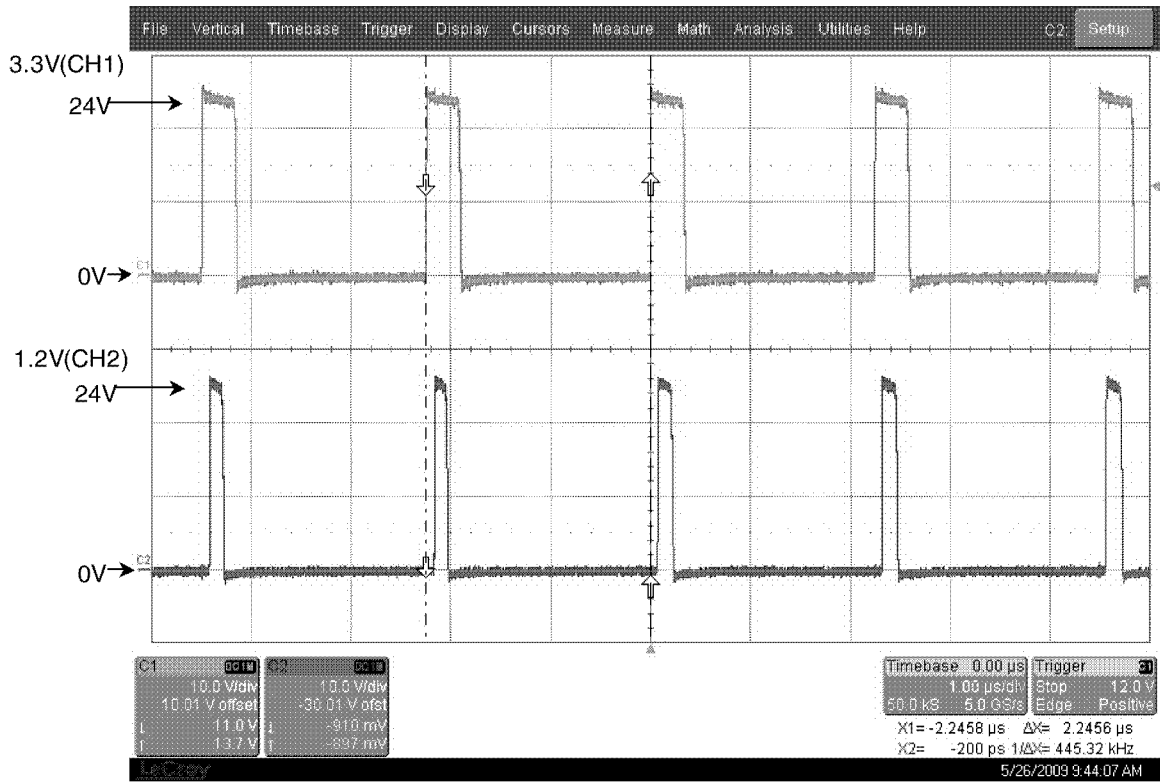

6.16. Power Supply Board Section

The power supply board circuit generates +7V and +24Vdc. It also supplies AC voltage to the halogen heat lamp in the fuser unit. The power supply board uses the switching regulator method.

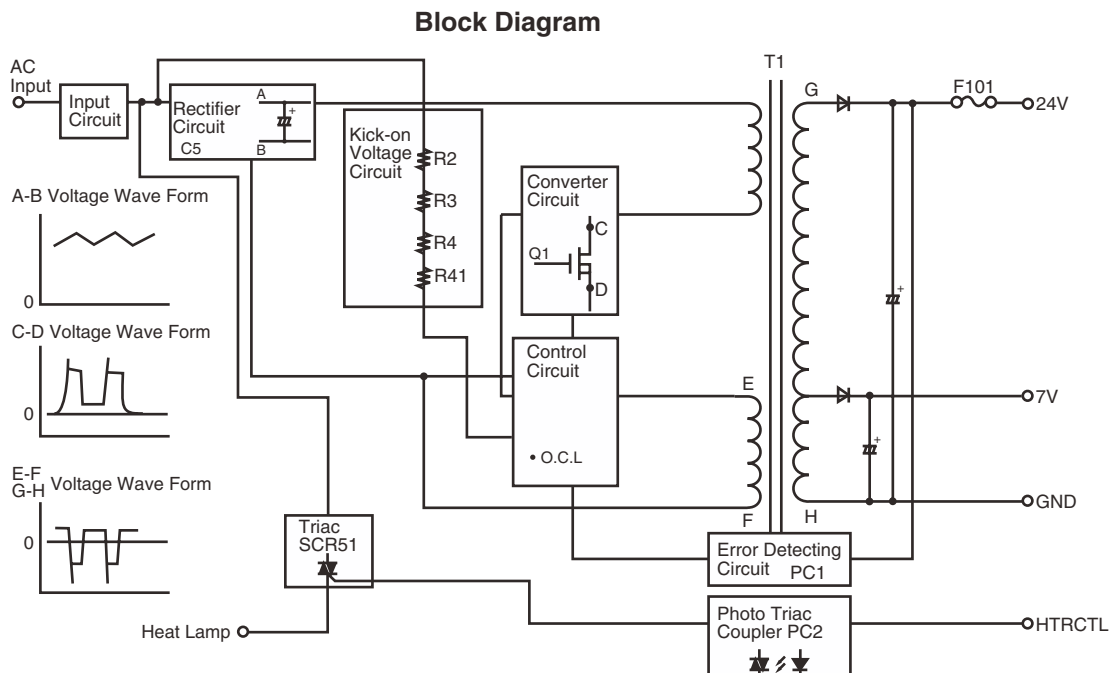

[Input Circuit]

The input current goes into the input rectifier circuit through the filter circuit.
The filter circuit decreases the noise voltage and the noise electric field strength.

[Rectifier Circuit]

The input circuit is rectified by D1 and charge C5 to make DC voltage.
Then it supplies power to the converter circuit.

[Kick-on Voltage Circuit]

Bias is applied to the Q1 gate via this circuit when the AC power is turned on and Q1 begins operating.

[Over Current Limiter (O.C.L.)]

The highest drain current of Q1 is limited by a limit current circuit. The 24V output is limited by this circuit.

[Over Voltage Circuit]

If the 24V output increases because the error detecting circuit or control circuit is broken.
Control circuit will recognize this signal and output becomes 0V. D104 and D503 also prevent over voltage.

Dummy load method (to quickly check the power supply output)

Refer to **Power Supply Board Section (P.151)**

6.17. Mechanical Operation

6.17.1. Printing

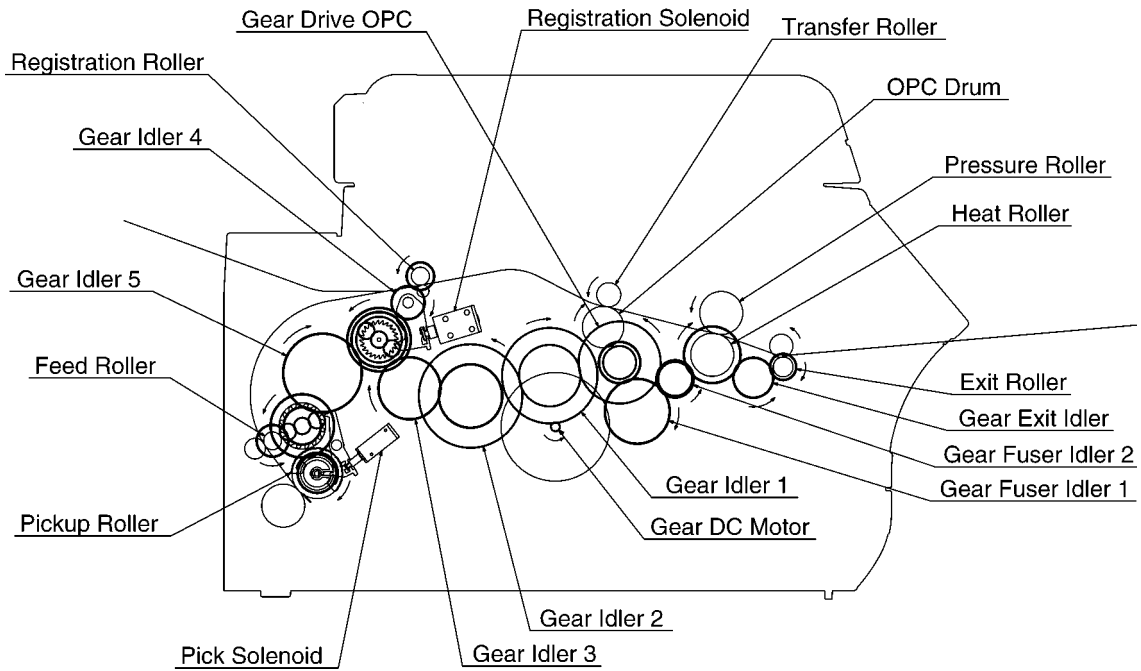

The main motor gear rotates as shown in figure.

GEAR DRIVE OPC drives each part of fixing and developing.

When paper is fed from the standard cassette, the plunger of solenoid is pulled to drive PICK UP ROLLER (STANDARD), then the roller starts feeding paper.

When paper is fed manually, first the plunger of solenoid is pulled to stop REGISTRATION ROLLER. After a few moments turn off the solenoid to drive REGISTRATION ROLLER, then the roller starts feeding paper.

6.17.2. Scanning (ADF) (KX-MB2010 ONLY)

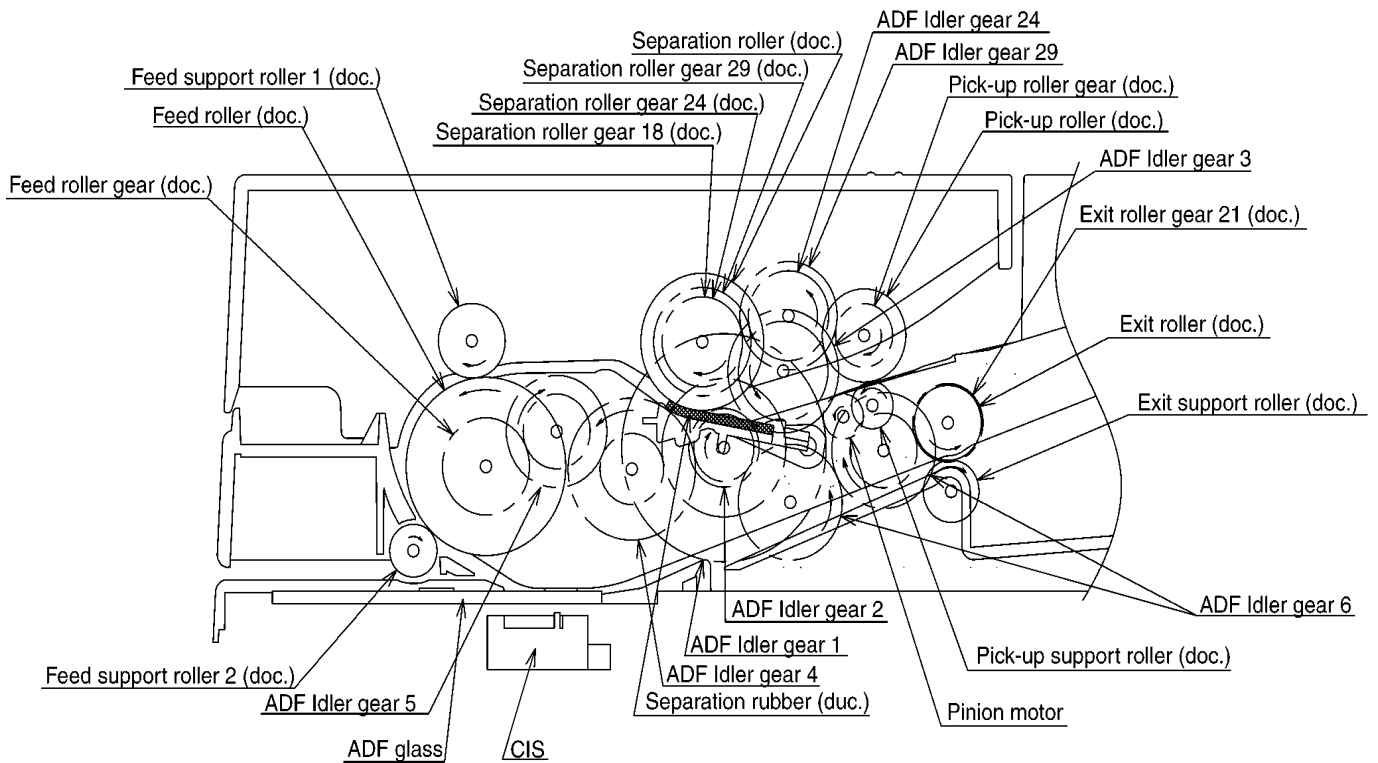

- DOCUMENT TRANSMISSION (ADF)

The frictional force between SEPARATION ROLLER (DOC.) and SEPARATION RUBBER makes PICK UP ROLLER (DOC.) move downward from standby position to pick up paper.

Pick-up paper is separated by SEPARATION ROLLER (DOC.) and SEPARATION RUBBER (DOC.), and then fed by FEED ROLLER (DOC.).

After being read by CIS, the paper is ejected by ROLLER DOC EJECT.

- DOCUMENT TRANSMISSION (SCANNER GLASS)

CIS Module is carried by the belt timing along the shaft carriage to the reading start position.

Then it goes back to the home position reading the document through the glass.

7 Location of Controls and Components

7.1. Overview

7.1.1. Front view

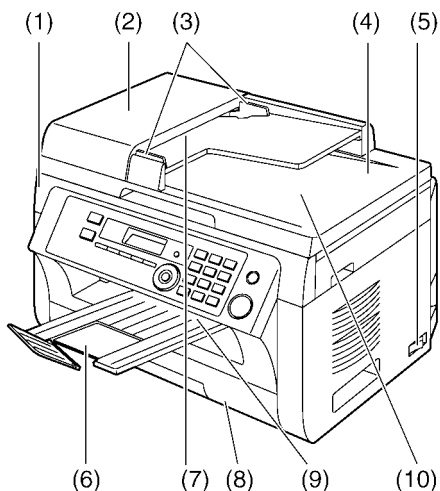

- (1) Top cover
- (2) ADF (Automatic Document Feeder) cover (KX-MB2010 only)
- (3) Document guides (KX-MB2010 only)
- (4) Document cover
- (5) Power switch
- (6) Output tray
- (7) Document entrance (KX-MB2010 only)
- (8) Paper input tray
- (9) Recording paper exit
- (10) Document exit (KX-MB2010 only)

* The pictured model is KX-MB2010.

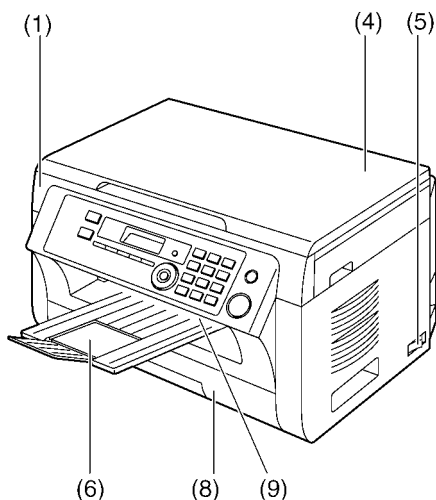

* The pictured model is KX-MB2000.

7.1.2. Rear view

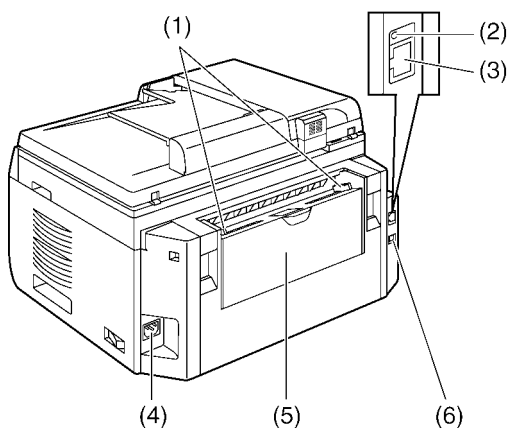

- (1) Recording paper guides
- (2) LED
- (3) LAN interface connector
- 10Base-T/100Base-TX
- (4) Power inlet
- (5) Manual input tray (Rear cover)
- (6) USB interface connector

*The pictured model is KX-MB2010.

7.2. Control Panel

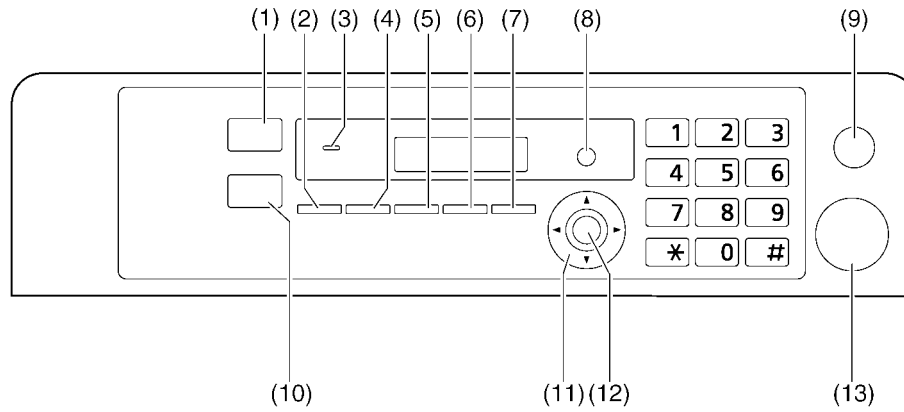

- (1) Scan
- (2) Copy Size
- (3) For beep sounds
- (4) Contrast
- (5) Resolution
- (6) Zoom
- (7) Page Layout
- (8) Menu
- (9) Stop
- (10) Copy
- (11) Navigator key
- (12) Set
- (13) Start

8 Installation Instructions

8.1. Installation

8.1.1. Installation Space

The space required to install the unit is shown below.

The dimensions given are necessary for the unit to operate efficiently.

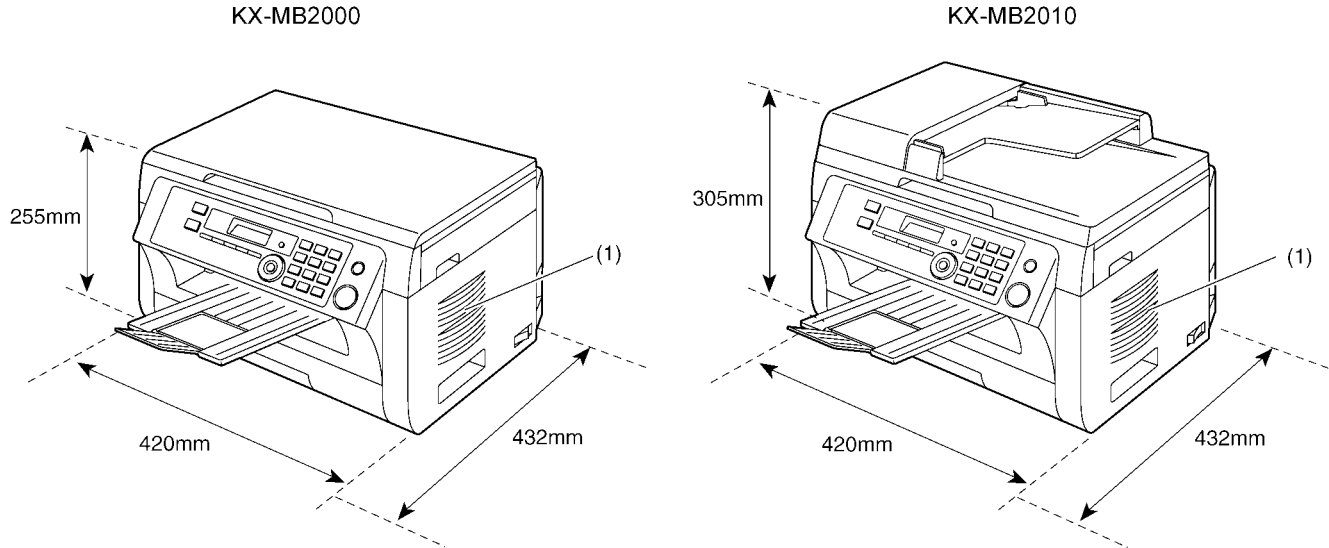

Note:

- Avoid excessive heat or humidity.
- Use the unit within the following ranges of temperature and humidity.
- Ambient temperature: 10°C to 32.5°C
- Relative humidity: 20% to 80% (without condensation)
- Power cord length should be less than 5 meters. Using a longer cord may reduce the voltage or cause malfunctions.
- Avoid direct sunlight.
- Do not install near devices which contain magnets or generate magnetic fields.
- Do not subject the unit to strong physical shock or vibration.
- Keep the unit clean. Dust accumulation can prevent the unit from functioning properly.
- To protect the unit from damage, hold both sides when you move it.
- Do not place the unit in an area where the paper tray may be obstructed (i.e., by a wall, etc.)
- Keep this surface (1) away from walls etc. more than 50 mm to let the unit cool down.

8.1.2. OUTPUT TRAY

1. Insert the output tray extender (1) until it clicks into place, and then press the centre part (2) of the extender to open it.

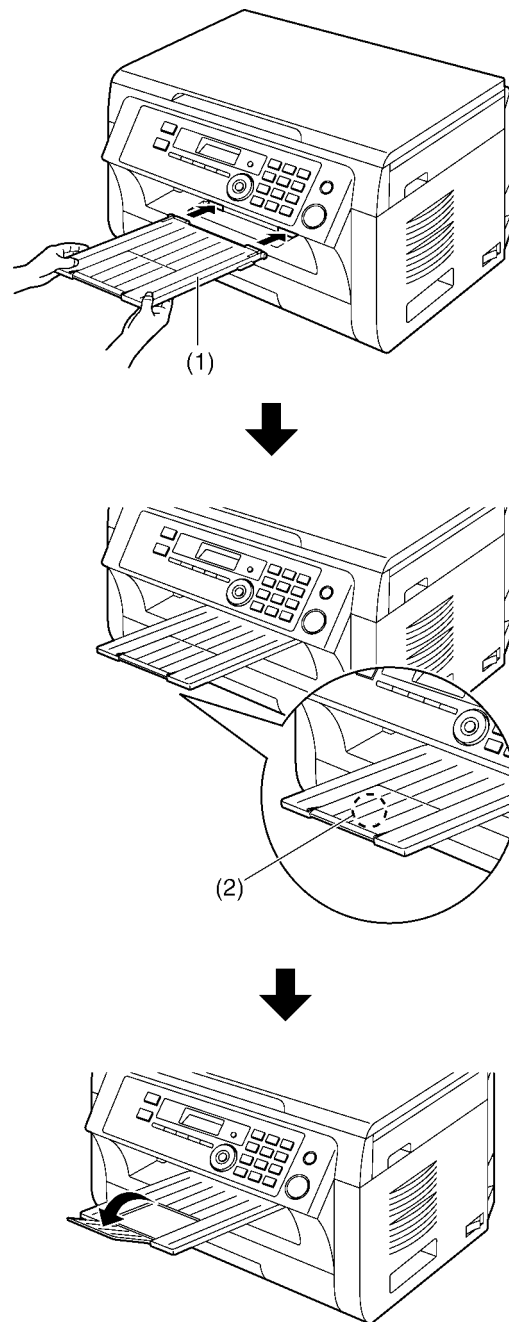

Note:

- Do not place the unit in an area where the output tray may be easily bumped into.
- The output tray can hold up to approximately 100 sheets of printed paper (the number of sheets may vary depending on the usage environment). Remove the printed paper before the output tray becomes full.

8.1.3. RECORDING PAPER

The paper input tray unit can hold:

- Up to 250 sheets of 60 g/m² to 75 g/m² paper.
- Up to 230 sheets of 80 g/m² paper.
- Up to 200 sheets of 90 g/m² paper.
- A4, letter, B5 and 16K-size paper can be used. B5 and 16K-size paper can only be used when using the unit for printing or copying.
- The unit is set for printing A4-size plain paper by default.
 - To use other paper sizes, change the recording paper size setting (feature #380).
 - To use thin paper, change the recording paper type setting (feature #383).

Note for recording paper:

- We recommend that you test paper (especially special sizes and types of paper) on the unit before purchasing large quantities.
- Do not use the following types of paper:
 - Paper with cotton and/or fibre content that is over 20 %, such as letterhead paper or paper used for resumes
 - Extremely smooth or shiny paper, or paper that is highly textured
 - Coated, damaged or wrinkled paper
 - Paper with foreign objects attached, such as tabs or staples
 - Paper that has dust, lint or oil stains
 - Paper that will melt, vaporize, discolour, scorch or emit dangerous fumes near 200 °C, such as vellum paper. These materials may transfer onto the fusing roller and cause damage.
 - Moist paper
 - Inkjet paper
- Some paper is designed to be printed on only one side. Try printing on the other side of the paper if you are not happy with the print quality, or if misfeeding occurs.
- For proper paper feeding and best print quality, we recommend using long-grained paper.
- Do not use paper of different types or thicknesses at the same time. This may cause paper jams.
- Avoid double-sided printing.
- Do not use paper printed from this unit for double-sided printing with other copiers or printers. This may cause paper jams.
- To avoid curling, do not open paper packs until you are ready to use the paper. Store unused paper in the original packaging, in a cool and dry location.
- For customers who live in high humidity areas:
- Please be sure to store paper in an air-conditioned room at all times. If you print using moist paper, it may cause paper jam.

1. Pull the paper input tray (1) until it clicks into place, then pull it completely out, lifting the front part of the tray.

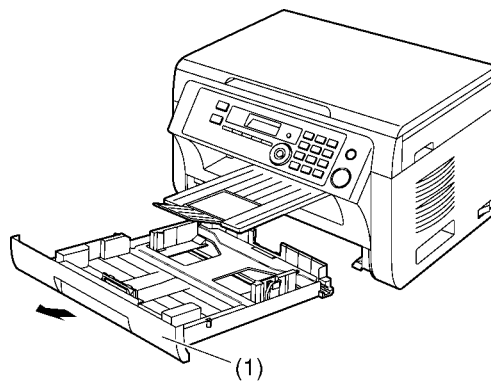

2. Before loading a stack of paper, fan the paper to prevent paper jams.

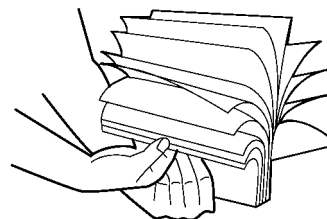

3. Load the paper, print-side up (2).

Important:

- Push down to lock the plate (3) in the paper input tray, if necessary.

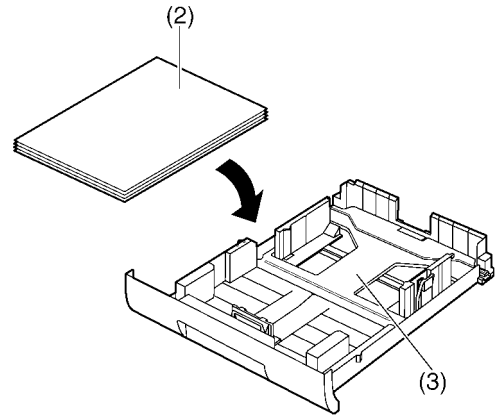

4. Adjust the recording paper guides. Pinch the front side of the recording paper guide (4), then slide it to match the paper size mark. Pinch the right side of the recording paper guide (5), then slide it to adjust the width to the size of the recording paper.
- Make sure that the recording paper is under the paper limit mark (6), and the paper should not be loaded over the snubbers (7).

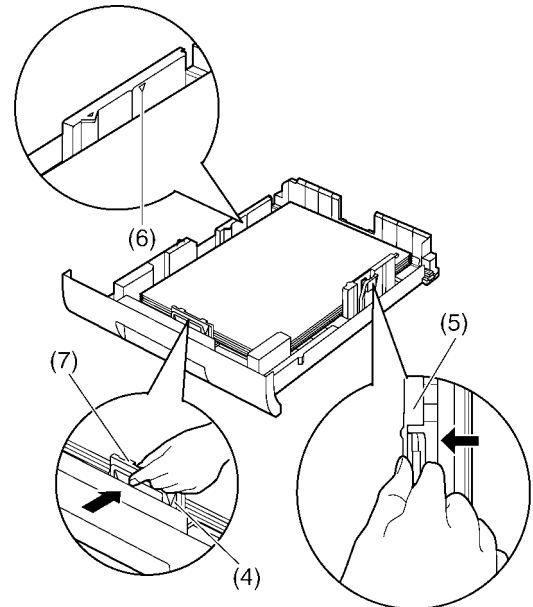

5. Insert the paper input tray into the unit, lifting the front part of the tray. Then push it completely into the unit.

Note:

- If the paper is not loaded correctly, re-adjust the paper guides, or the paper may jam.
- If the paper input tray does not close, the plate in the paper input tray may not be in the locked position. Push the paper down and make sure that the paper is laying flat in the paper input tray.

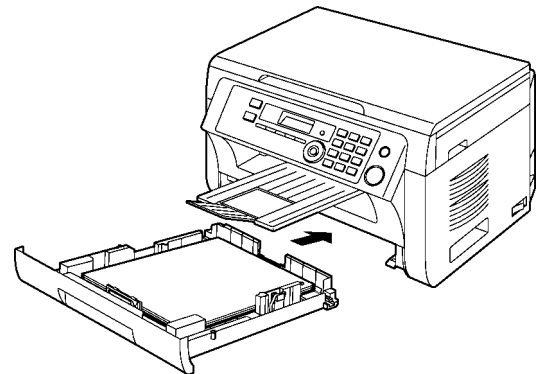

Caution for the paper input tray

- Do not drop the paper input tray.

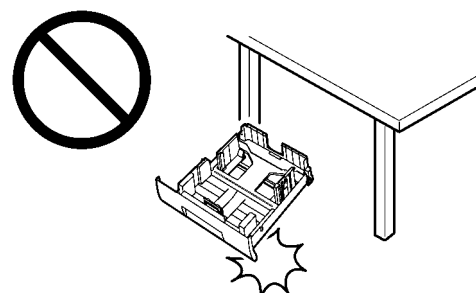

- Hold the paper input tray with both hands when removing or installing. The paper input tray weighs approximately 2 kg when fully loaded with recording paper.

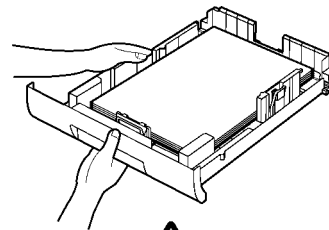

Approx. 2 kg

8.1.3.1. Using the manual input tray

You can use the manual input tray for printing with the computer and for copying. It can hold one page at a time. When printing or copying multiple pages, add a next page after the first page has been fed into the unit.

- The unit is set for printing A4-size plain paper by default.
 - To use other paper sizes, change the recording paper size setting (feature #381).
 - To use thin paper, change the recording paper type setting (feature #384).

1. Adjust the width of the guides (1) to the size of the recording paper.
2. Insert the paper, print-side down (2) until the unit grasps the paper and a single beep is heard.

Note:

- To print from the manual input tray;
 - when printing with the computer, select #2 for the printer properties.
 - when making a copy, set the copy input tray setting to "#2" beforehand (feature #460).
 If these settings are not changed, when printing or copying multiple pages, the 1st page will be printed from the manual input tray, but the rest of the pages will be printed from the paper input tray.
- If the paper is not inserted correctly, re-adjust the paper, or the paper may jam.

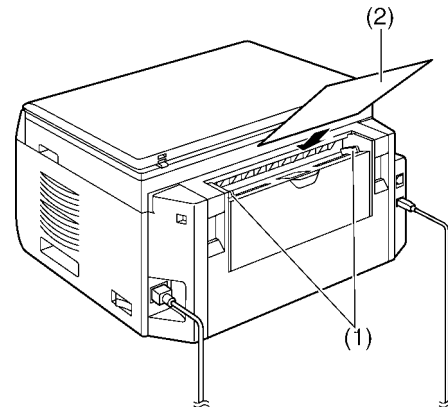

8.1.4. Documents the Unit Can Send

8.1.4.1. Using the auto document feeder (KX-MB2010 ONLY)

Note:

- Confirm that there are no documents on the scanner glass.
- Confirm that any ink, paste or correction fluid has dried completely.
- Remove clips, staples or other fasteners.
- Do not insert the following types of documents (Make a copy of the document using the scanner glass and set the copy instead.):
 - Chemically treated paper such as carbon or carbonless duplicating paper
 - Electrostatically charged paper
 - Badly curled, creased or torn paper
 - Paper with a coated surface
 - Paper with printing on the opposite side that can be seen through the other side, such as newsprint
- The total height of the documents when laid flat, must be less than 4 mm. If the documents exceed the capacity of the automatic document feeder, they may fall or cause a jam in the feeder.
- To set a document with a width of less than 210 mm, we recommend using the scanner glass to copy the original document onto A4 or letter-size paper, then setting the copied document for better results.
- Do not set documents that do not satisfy the requirements of size and weight. Make a copy of the document using the scanner glass and set the copy.
- Available document size, document weight and effective scanning area are as follows:

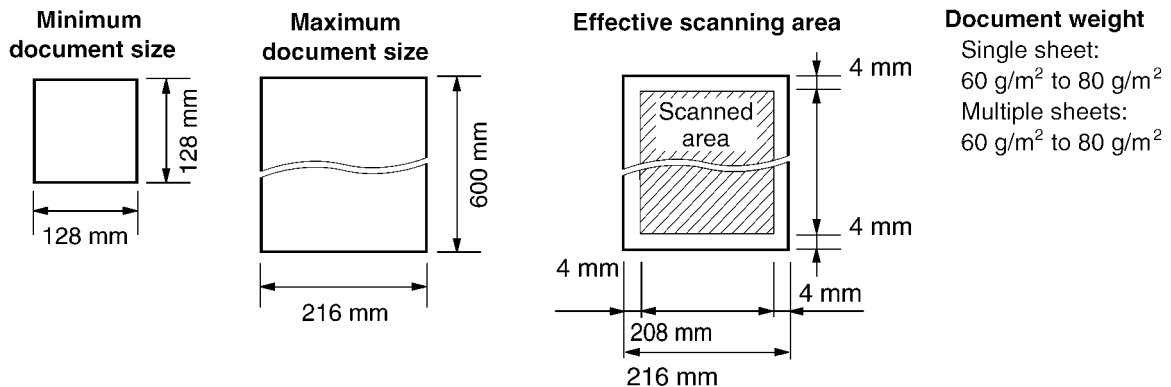

- Shaded area will be scanned.
- When using the unit as a scanner, the effective scanning length depends on the selected paper size.

8.1.4.2. Using the scanner glass

Note:

- Confirm that there are no documents in the automatic document feeder (KX-MB2010 only).
- Place the original onto the scanner glass gently. To avoid malfunction, do not press down too firmly.
- If the original is a thick book, do not close the document cover.
- Confirm that any ink, paste or correction fluid has dried completely.
- Effective scanning area is shown by the shaded area:

Effective scanning area

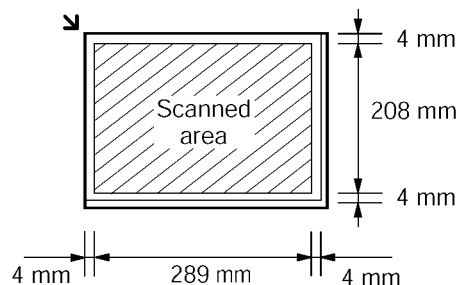

8.1.5. Toner Cartridge and the Drum Cartridge

The supplied toner cartridge is a starter toner cartridge.

Caution:

- Read the following instructions before you begin installation. After you have read them, open the drum cartridge protective bag. The drum cartridge contains a photosensitive drum. Exposing it to light may damage the drum. Once you have opened the protective bag:
 - Do not expose the drum cartridge to light for more than 5 minutes.
 - Do not touch or scratch the black drum surface inside of the drum cartridge.
 - Do not place the drum cartridge near dust or dirt, or in a high humidity area.
 - Do not expose the drum cartridge to direct sunlight.
- Do not leave the toner cartridge out of the protective bag for a long time. It will decrease the toner life.
- We cannot be responsible for any damage to the unit or degradation of print quality which may occur from the use of a non-Panasonic toner and drum cartridges.
- Do not add toner to the toner cartridge.

1. Before opening the protective bag of the new toner cartridge, shake it vertically more than 5 times.



2. Remove the toner cartridge and drum cartridge from the protective bags. Peel off the seal (1) from the toner cartridge.
 - Do not touch or scratch the black drum surface (2).

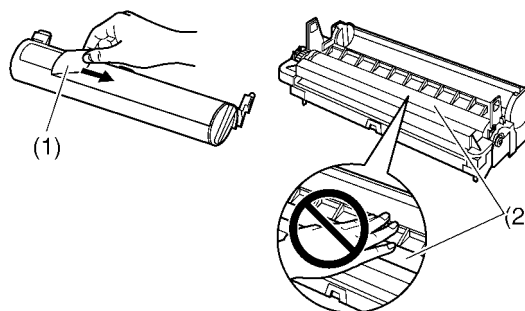

3. Place the toner cartridge (3) into the drum cartridge (4) vertically.

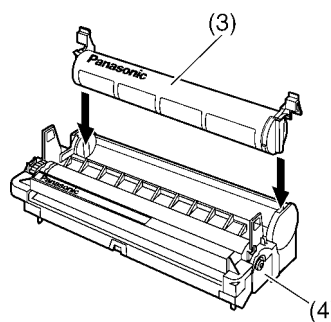

4. Press down the toner cartridge firmly (5). Keep pressing while turning the green lever on each side of the toner cartridge towards you (6).

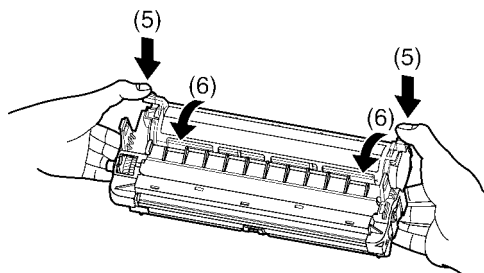

5. Make sure that the arrows (7) match, to install the toner cartridge correctly.

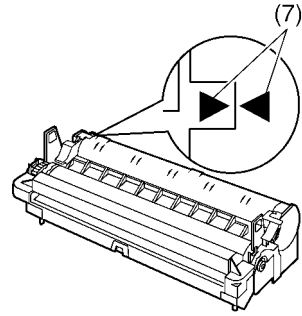

6. Open the top cover (8) by holding the indentations (9) on both sides of the unit.

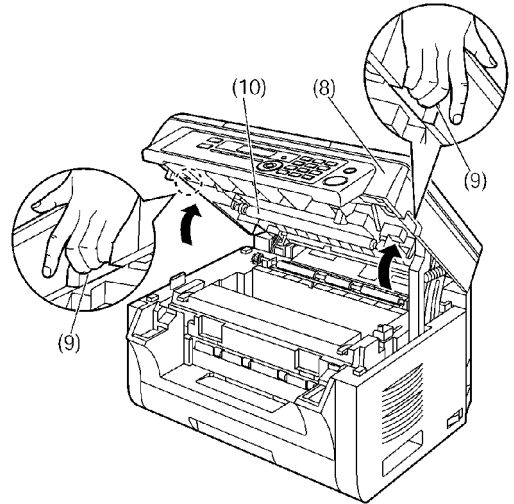

Note:

- Do not touch the transfer roller (10).
- If the lower glass (11) is dirty, clean it with a soft and dry cloth.

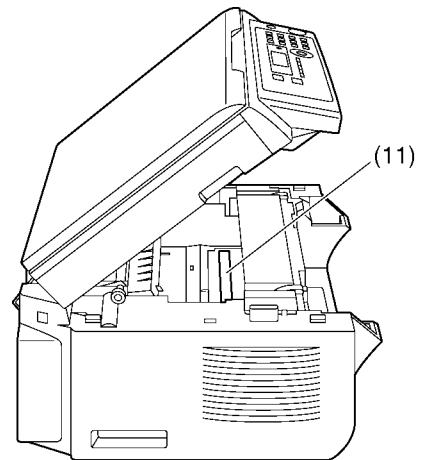

7. Install the drum and toner cartridge (12) by holding the tabs.

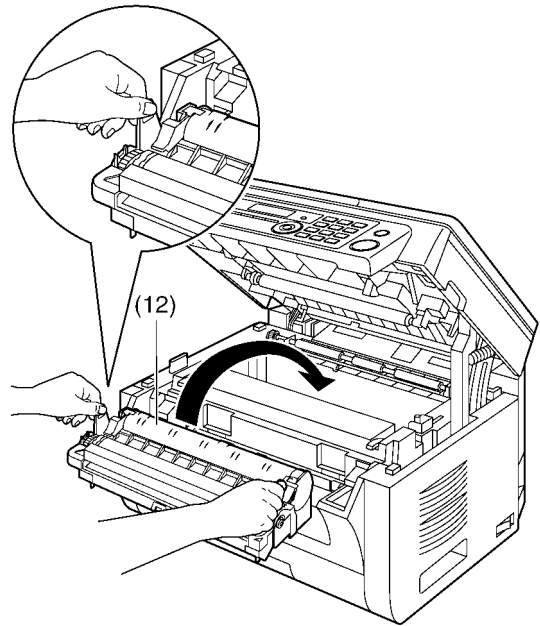

- Make sure that the arrows (13) match, to install the drum and toner cartridge correctly.

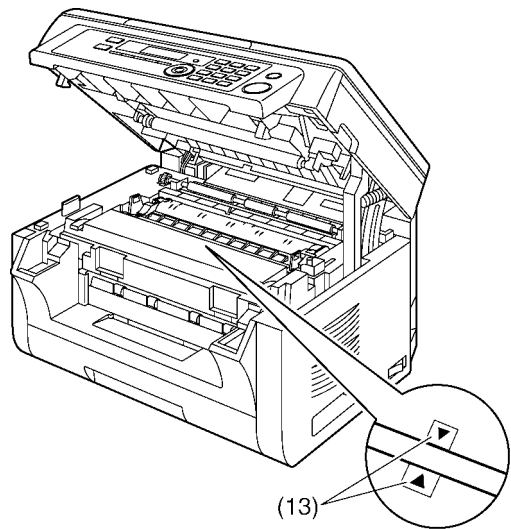

8. Close the top cover by holding the indentations on both sides of the unit, until locked.

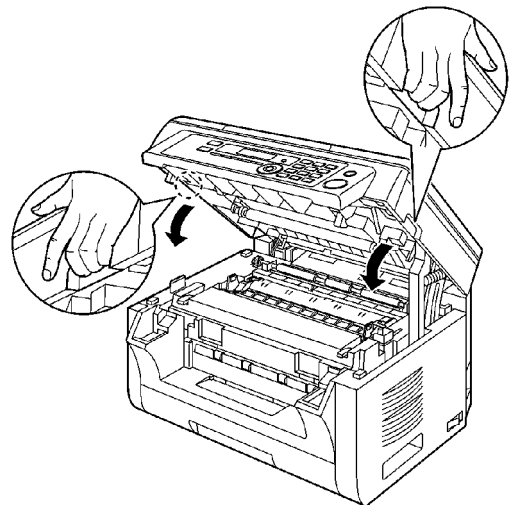

Caution:

- To prevent injuries, be careful not to put your hands under the top cover.

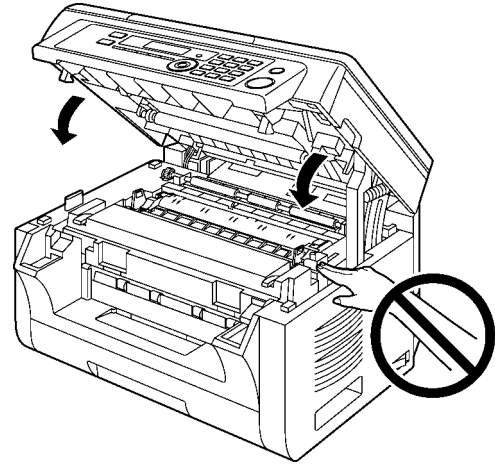

8.1.5.1. When to replace the toner cartridge and the drum cartridge

When the display shows the following, replace the toner cartridge.

- “TONER LOW”
- “TONER EMPTY”

Note:

- To check the drum life and quality, please print the printer test list (Refer to **ITU-T No.1 Test Chart** (P.204)). If printing quality is still poor or “REPLACE DRUM” appears on the display, replace the toner cartridge and drum cartridge.
- To ensure that the unit operates properly, we recommend the use of Panasonic toner and drum cartridges. (Refer to **Optional Accessories** (P.11)).
- To maintain print quality and machine life, we recommend you to clean slots and openings and the inside of the unit when replacing the toner cartridge and/or drum cartridge.

Waste disposal method

Waste material should be disposed of under conditions which meet all national and local environmental regulations.

Toner save feature

- If you want to reduce toner consumption, set the toner save setting to ON (feature #482). The toner cartridge will last approximately 20 % longer. This feature may lower the print quality.

8.1.6. Connecting to a computer

Panasonic Multi-Function Station software enables the unit to carry out the following functions:

- Printing on plain paper, thin paper and labels
- Previewing documents and changing printer settings before printing (Easy Print Utility)
- Scanning documents and converting an image into text with Readiris OCR software
- Scanning from other applications for Microsoft® Windows® that support TWAIN scanning and WIA scanning (Windows XP/Windows Vista®, USB connection only)
- Programming the features using your computer

To use Multi-Function Station on your computer, the following are required:

Operating System:

Windows 2000/Windows XP/Windows Vista

CPU:

Windows 2000: Pentium® II or higher processor

Windows XP: Pentium III or higher processor

Windows Vista: Pentium 4 or higher processor

RAM:

Windows 2000/Windows XP: 128 MB (256 MB or more recommended)

Windows Vista: 512 MB (1,024 MB or more recommended)

Other Hardware:

CD-ROM drive

Hard disk drive with at least 200 MB of available space

USB interface

LAN interface (10Base-T/100Base-TX)

Other:

Internet Explorer® 5.0 or later

Warning:

- To assure continued emission limit compliance;
 - use only shielded USB cable (Example: Hi-Speed USB 2.0 certified cable).
 - use only shielded LAN cable (category 5 straight cable).
- To protect the unit, use only shielded USB cable in areas where thunderstorms occur.
- To use Easy Print Utility on your computer, the following are required:
 - Windows 2000 Service Pack 4 and Security update for Windows 2000 (KB835732).
Install KB835732 from Microsoft download site before installing Easy Print Utility.
 - Windows XP Service Pack 2 or later.

Note:

- A USB cable is not supplied. Please purchase a shielded Type-A male/Type-B male USB cable.

8.1.7. Installing Multi-Function Station

- **Install Multi-Function Station (CD-ROM) before connecting the unit to a computer with the USB cable. If the unit is connected to a computer with the USB cable before installing Multi-Function Station, the [Found New Hardware Wizard] dialogue box will appear. Click [Cancel] to close it.**
- **The screenshots shown in these instructions are for Windows XP and are included for reference only.**
- **The screenshots shown in these instructions may differ slightly from those of the actual product.**
- **Software features and appearance are subject to change without notice.**

1 Start Windows and exit all other applications.

- You must be logged in as an administrator in order to install Multi-Function Station.

2 Insert the supplied CD-ROM into your CD-ROM drive.

- If the **[Select Language]** dialogue box appears, select the language that you want to use with this software. Click **[OK]**.
- If the installation does not start automatically:

Click **[Start]**. Choose **[Run...]**. Type "D:\Install" (where "D:" is the drive letter of your CD-ROM drive). Click **[OK]**.

(If you are not sure what the drive letter is for your CD-ROM drive, use Windows Explorer and look for the CD-ROM drive.)

3 [Easy Installation]

- The installation will start automatically.

4 When the setup program starts, follow the on-screen instructions.

- Easy Print Utility, Readiris OCR software and Device Monitor will also be installed.

5 The **[Connect Type]** dialogue box appears.

For USB connection:**1 [Connect directly with a USB cable.]→ [Next].**

- The **[Connect Device]** dialogue box will appear.

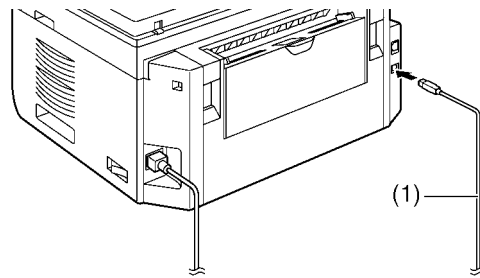
2 Connect the unit to a computer with the USB cable (1), then click [Next].

- If the unit is connected to your computer, the model name will be automatically detected.
- You can change the name of the unit if necessary.

3 Click [Install], then follow the on-screen instructions.

- The files will be copied to your computer.

For LAN connection**1. [Connect via the Network.] → [Next]**

- The **[Select a Network Device]** dialogue box will appear.

2. Check [Select in the searched list] and select the unit from the list.

- If the name of the desired unit is not displayed on the list, and the IP address for the unit has been assigned, check **[Direct input]** and enter the IP address.

3. [Next]

- You can change the name of the unit if necessary.

4. Click [Install], then follow the on-screen instructions.

- The files will be copied to your computer.

Important notice

If you are using Windows XP or Windows Vista, a message may appear after connecting the unit with the USB cable. This is normal and the software will not cause any difficulties with your operating system. You can continue the installation with no problem. This kind of message is displayed:

• For Windows XP users

"The software you are installing for this hardware has not passed Windows Logo testing to verify its compatibility with Windows XP."

• For Windows Vista users

"Would you like to install this device software?"

8.2. Connections

Caution:

- **When you operate this product, the power outlet should be near the product and easily accessible.**
 - (1) Power cord
- Connect to a power outlet.
(220-240 V, 50/60 Hz).
- (2) To the Internet
- (3) Network router/Network hub (not supplied)
- Also connect networked computers.
- (4) LAN cable (not supplied)
- To assure continued emission limit compliance, use only shielded LAN cable (category 5 straight cable).

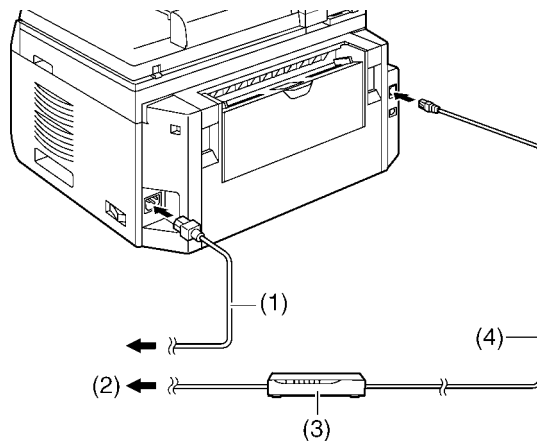

* The pictured model is KX-MB2010.

Important notice for the USB connection

- DO NOT CONNECT THE UNIT TO A COMPUTER WITH THE USB CABLE UNTIL PROMPTED TO DO SO DURING THE SETUP OF MULTI-FUNCTION STATION.

Note:

- Do not place any objects within 10 cm of the right, left and back sides of the unit.

Using network router/network hub

- We recommend using network routers/network hubs (3) under secure network environments. Consult your network administrator for firewall settings, etc.
- The warranty does not cover damage due to security problems or any inconveniences relating to it.

9 Operating Instructions

9.1 To Select Characters with the Dial Keypad

The dial keypad is used to enter characters and numbers.

- Press [◀] or [▶] to move the cursor.
- Press the dial keys to enter characters and numbers.
- Press [Stop] to erase the character or number highlighted by the cursor. Press and hold [Stop] to erase all characters or numbers.
- To enter another character located on the same dial key, press [▶] to move the cursor to the next space, then press the appropriate dial key.

Keypad	Characters
[1]	1 . _ - [] { } + / = , ' : ; ?
[2]	A B C 2
	a b c 2
[3]	D E F 3
	d e f 3
[4]	G H I 4
	g h i 4
[5]	J K L 5
	j k l 5
[6]	M N O 6
	m n o 6
[7]	P Q R S 7
	p q r s 7
[8]	T U V 8
	t u v 8
[9]	W X Y Z 9
	w x y z 9
[0]	0 @ () < > ! " # \$ % & ¥ * ^ ' →
[*]	To switch between uppercase or lowercase letters.
[Zoom]	To insert a space.
[Stop]	To delete a character.

9.2 To Select Characters Using [▼] or [▲]

Instead of pressing the dial keys, you can select characters using [▼] or [▲].

1. Press [▼] repeatedly to display the desired character.
Characters will be displayed in the following order:
 - ① Uppercase letters
 - ② Numbers
 - ③ Symbols
 - ④ Lowercase letters*¹

*¹ When you enter email address (i.e. scan to email address), lowercase letters will be displayed first (LAN connection only).

 - If you press [▲], the order will be reversed.
2. Press [▶] to insert the displayed character.
3. Return to step 1 to enter the next character.

10 Test Mode

10.1. Test Functions

The codes listed below can be used to perform simple checks of some of the unit's functions. When complaints are received from customers, they provide an effective tool for identifying the locations and causes of malfunctions.

Test Mode	Type of Mode	Code	Function
		Operation after code input	
MEMORY CLEAR	Service Mode	"5" "5" "0"	Clear the memory where the users can store data.
		SET	
MOTOR TEST	Service Mode	"5" "5" "6"	00:printer motor feed 10:auto document feed 20:carriage
		SET	
ROM CHECK	Service Mode	"5" "5" "1"	Indicates the version and checks the sum of the ROM.
		SET	
LCD TEST	Service Mode	"5" "5" "8"	Checks the LCD indication. Illuminates all the dots to check if they are normal.
		SET	
LED TEST	Service Mode	"5" "5" "7"	All LEDs above the operation panel board flash on and off, or are illuminated.
KEY TEST	Service Mode	"5" "6" "1"	Checks the button operation. Indicates the button code on the LCD while the button is pressed. Refer to Button Code Table (P.81).
		START (any key)	
SCANNER TEST	Service Mode	"5" "5" "5"	LED lights up, Scanner scanning. 1:RED / 2:GREEN / 3:BLUE / 4:monochrome / 5:Color
LSU TEST	Service Mode	"6" "3" "9"	Laser radiates, Polygon rotates
High Voltage Power Supply Board CHECK	Service Mode	"6" "2" "8"	Refer to High Voltage Value Check Point (P.132).
		SET	
FAN TEST	Service Mode	"6" "7" "7"	1:TEST OFF 2:FAN 1 & 2 High-speed rotation 3:FAN 1 & 2 Low-speed rotation 4:FAN 1 & 2 STOP
MEMORY CLEAR (except History data)	Service Mode	"7" "1" "0"	Refer to Memory Clear Specification (P.84).
		SET	
PRINT TEST PATTERN	Service Mode	"8" "5" "2"	1. Press "852" then the SET key in the service mode. 2. As "PATNO. =" is displayed on the LCD, enter the test pattern No. and press the SET key. 3. When "NO. =" is displayed on the LCD, enter the printing number and press the SET key. (Press "00" for the infinite printing.) 4. "MODE=" is displayed on the LCD. Press "0" to start printing or press "1" to go to the next screen. 5. When "1" is pressed at MODE, "INTVL =" is displayed on the LCD. Enter the printing interval (000~999 sec). 6. The printing repeats the designated number of times at the programmed printing intervals. Refer to Print Test Pattern (P.82)

Test Mode	Type of Mode	Code	Function
		Operation after code input	
SENSOR CHECK	Service Mode	"8" "1" "5"	<p>First of all, press the copy button, and confirm the action of ON/OFF. For each sensor's operation, refer to Sensors and Switches Section (P.40). LCD DISPLAY:</p> <div style="border: 1px solid black; padding: 5px; width: fit-content; margin: 10px auto;"> <p>D S C * R E * T * 3 F * D F * * * U T * * H * * * * * * * * * *</p> </div> <p>D: Document (KX-MB2010 ONLY) D: Document set -: No document</p> <p>S: Read position (KX-MB2010 ONLY) S: Docu detect -: No document</p> <p>C: Top cover C: Cover open -: Cover close</p> <p>*: None</p> <p>R: Registration R: Paper detect -: No paper</p> <p>E: Paper exit E: Paper detect -: No paper</p> <p>*: None</p> <p>T: Toner T: Toner detect -: No toner</p> <p>*: None</p> <p>3F: Fuser thermistor 3F: 00 (high temp.) - FF (low temp.)</p> <p>*: None</p> <p>DF: Fuser thermistor DF: 00 (high temp.) - FF (low temp.)</p> <p>*: None</p> <p>*: None *: None U: Pickup/Rear Cover U: Paper detect -: No paper</p> <p>T: Print timing T: Paper detect -: No paper</p> <p>*: None *: None H: Carriage H: Carriage detect -: No carriage</p> <p>*: None *: None *: None *: None *: None *: None *: None *: None *: None *: None</p>

Note:

The numbers in the boxes (XXX) indicate the keys to be input for the various test modes.

10.1.1. Button Code Table

Code	Button Name	Code	Button Name	Code	Button Name
31	1	41	START	52	PAGE LAYOUT
32	2	40	SET	-	STOP
33	3	44	MENU	8C	COPY SIZE
34	4	66	NAVIGATOR ←		
35	5	65	NAVIGATOR →		
36	6	46	NAVIGATOR ↑		
37	7	47	NAVIGATOR ↓		
38	8	61	COPY MODE		
39	9	62	SCAN MODE		
30	0	5D	CONTRAST		
3B	✕	5C	RESOLUTION		
3C	#	5F	ZOOM		

10.1.2. Print Test Pattern

1. NO.01

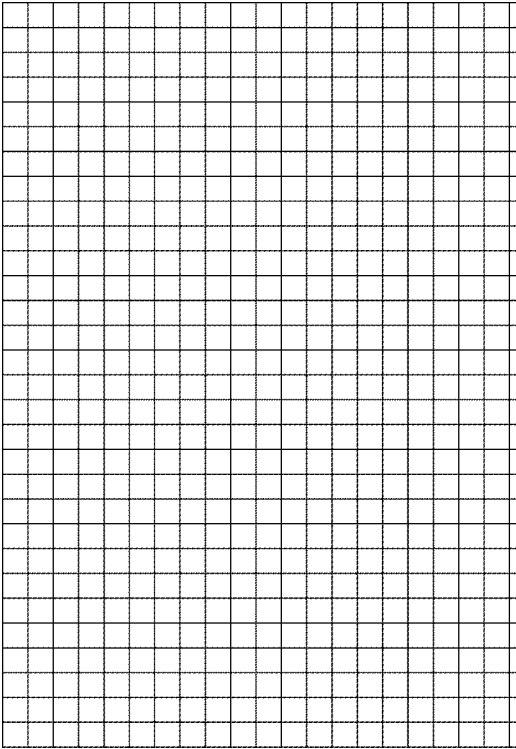

2. NO.06

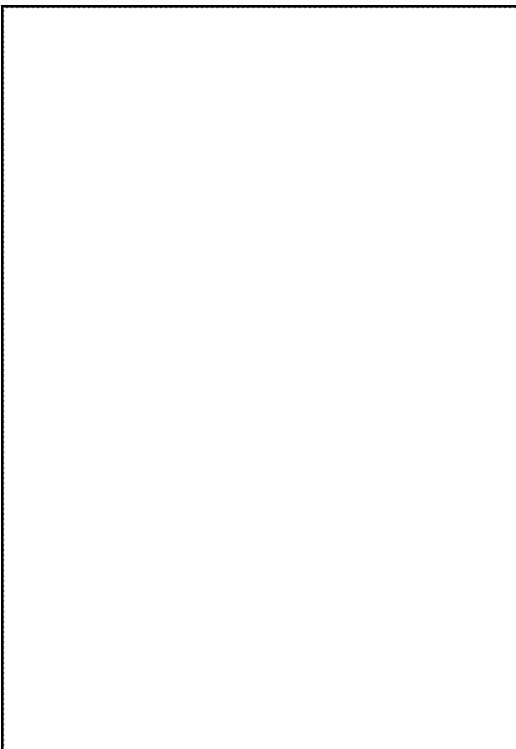

3. NO.03

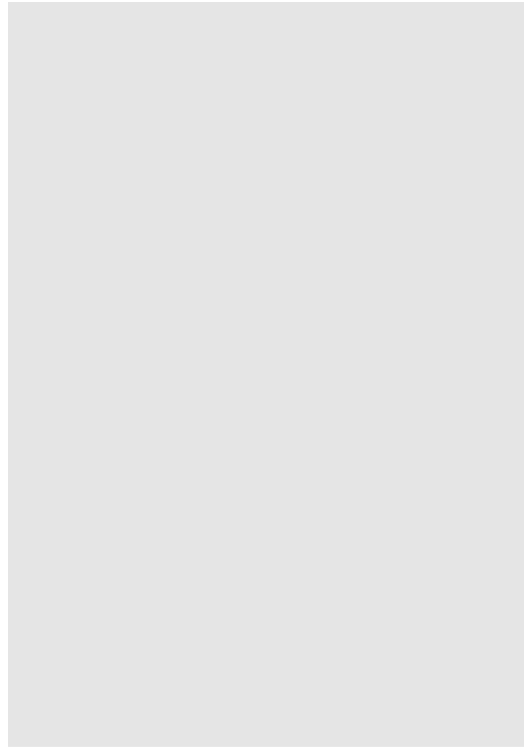

- These print test patterns are just image printing, and different from actual ones.
- When it is required to judge the print quality, compare with the printing of a nondefective machine.

11 Service Mode

The programming functions are used to program the various features and functions of the machine, and to test the machine. This facilitates communication between the user and the service man while programming the unit.

11.1. Programming and Lists

11.1.1. Operation

There are 2 basic categories of programming functions, the User Mode and the Service Mode. The Service Mode is further broken down into the normal and special programs. The normal programs are those listed in the Operating Instructions and are available to the user. The special programs are only those listed here and not displayed to the user. In both the User and Service Modes, there are Set Functions and Test Functions. The Set Functions are used to program various features and functions, and the Test Functions are used to test the various functions. The Set Functions are accessed by entering their code, changing the appropriate value, then pressing the SET key. The Test Functions are accessed by entering their code and pressing the key listed on the menu. While programming, to cancel any entry, press the STOP key.

11.1.2. Operation Flow

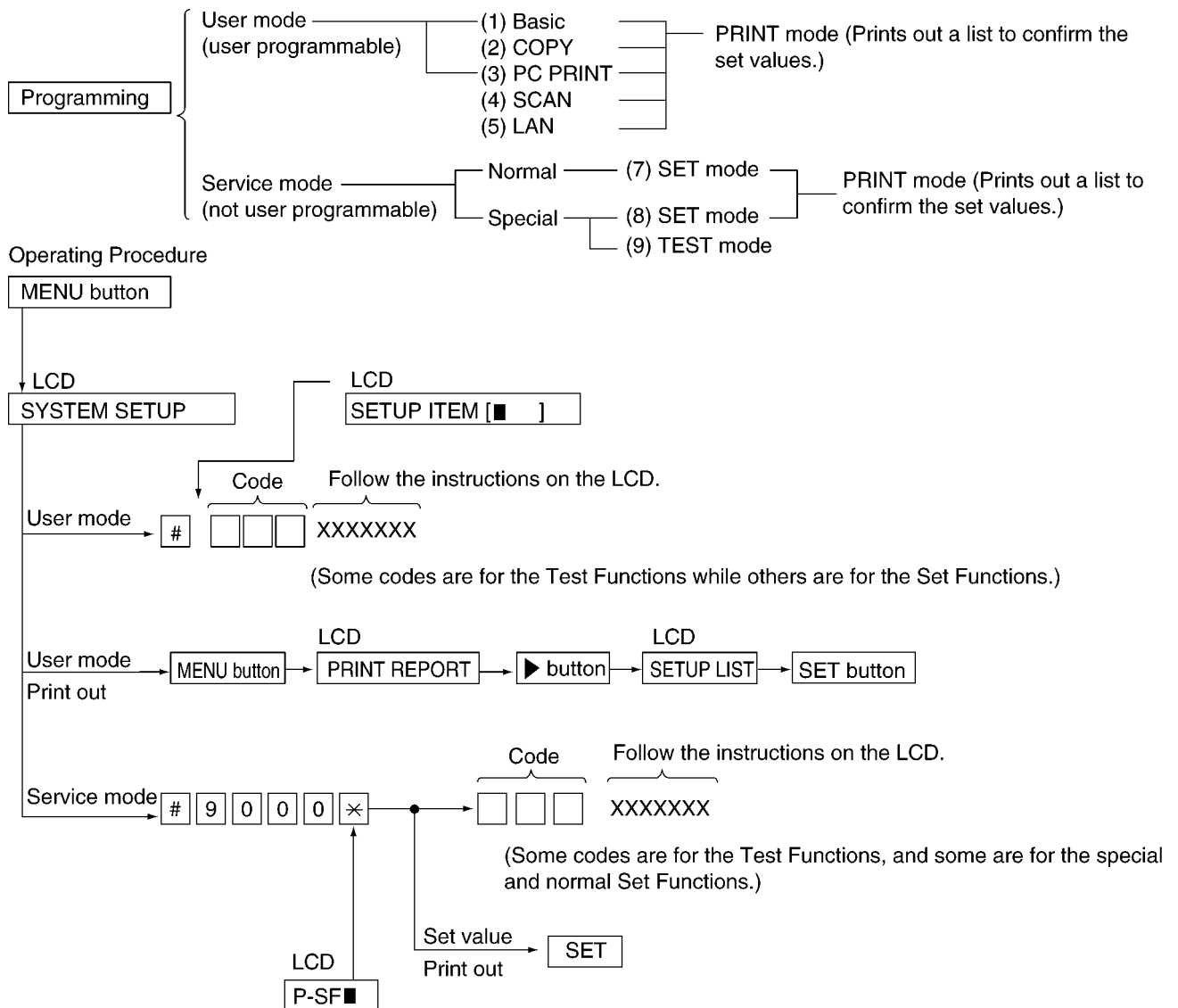

11.1.3. Service Function Table

Code	Function	Set Value	Effective Range	Default	Remarks
529	Call Service Clear				
550	Memory clear				Refer to Memory Clear Specification (P.84).
551	ROM check				See Test Functions (P.80).
555	Scanner test				See Test Functions (P.80).
556	Motor test			0	See Test Functions (P.80).
557	LED test				See Test Functions (P.80).
558	LCD test				See Test Functions (P.80).
561	KEY test				See Test Functions (P.80).
628	H.V.P.S. check				See Test Functions (P.80).
639	LSU test				See Test Functions (P.80).
655	Cause Distinction Code of Call Service 3				See CALL SERVICE Troubleshooting Guide (P.97).
677	FAN test				See Test Functions (P.80).
710	Memory clear except History data				Refer to Memory Clear Specification (P.84).
815	Sensor check				See Test Functions (P.80).
852	Print test pattern				See Test Functions (P.80).
853	Top margin		1~11	6	-----
854	Left margin		1~11	6	-----
880	History list				See History (Example of a printed out list) (P.87).

11.1.4. Memory Clear Specification

Item	Status after Memory Clear	
	Service Mode #550 ^{*1}	Service Mode #710 ^{*2}
Date and time (user mode #101)	—	Default
Password (user mode #155)	—	Default
History	—	—
Top margin (service mode #853)	—	—
Left margin (service mode #854)	—	—
Other Setting data (User setting and Service setting data)	Default	Default

— : Not changed

*1 Execute Service Mode #550 when you want to reset the all setting data keeping the user information.

*2 Execute Service Mode #710 to clear the user information in case that Main Unit is recycled.

Note:

Please restart a power supply after clearing a memory.

11.2. User Mode (The list below is an example of the SYSTEM SETUP LIST the unit prints out.)

(KX-MB2000)

SETUP LIST**[BASIC FEATURE LIST]**

NO.	FEATURE	CURRENT SETTING
#101	SRT DATE & TIME	01 Jan. 2010 00:00
#110	LANGUAGE	ENGLISH [ENGLISH, CZECH, SLOVAK, HUNGARIAN]
#145	LCD CONTRAST	NORMAL [NORMAL, DARKER]
#147	SCALE	MILLIMETRES [MILLIMETRES, INCHES]
#155	CHANGE PASSWORD	
#158	MAINTENANCE TIME	12:00 ← Set Value
#159	RESTORE DEFAULT	
#165	BEEP SOUND	ON [OFF, ON]
#380	PAPER SIZE #1	A4 [LETTER, A4, B5(ISO), B5(JIS), 16K]
#381	PAPER SIZE #2	A4 [LETTER, A4, LEGAL, B5(ISO), B5(JIS), 16K, 216X330, 216X340]
#383	MEDIA TYPE #1	PLAIN PAPER [PLAIN PAPER, THIN PAPER]
#384	MEDIA TYPE #2	PLAIN PAPER [PLAIN PAPER, THIN PAPER]
#403	POWER SAVE	5min [5min, 15min, 30min, 1h]
#462	CONTRAST HOLD	DISABLED [DISABLED, ENABLED]
#482	TONER SAVE	OFF [OFF, ON]

Code

[COPY FEATURE LIST]

NO.	FEATURE	CURRENT SETTING
#460	COPY INPUT TRAY	#1 [#1, #2]
#461	COPY RESOLUTION	TEXT/PHOTO [TEXT/PHOTO, TEXT, PHOTO]
#467	PAGE LAYOUT HOLD	DISABLED [DISABLED, ENABLED]
#468	ZOOM HOLD	DISABLED [DISABLED, ENABLED]
#469	COLLATE HOLD	DISABLED [DISABLED, ENABLED]
#473	EDGE HOLD	DISABLED [DISABLED, ENABLED]
#474	FRAME MARGIN	DISABLED [DISABLED, ENABLED]
#475	MARGIN HOLD	DISABLED [DISABLED, ENABLED]

Code

[PC PRINT FEATURE LIST]

NO.	FEATURE	CURRENT SETTING
#774	DATA TIMEOUT	60s [5...600(s)]
#776	MUTUAL A4/LETTER	ON [OFF, ON]

[SCAN FEATURE LIST]

NO.	FEATURE	CURRENT SETTING
#493	SCAN MODE	VIEWER [VIEWER, FILE, EMAIL, OCR]
#494	SCAN PARAM. HOLD	DISABLED ← Set Value [DISABLED, ENABLED]

[LAN FEATURE LIST]

NO.	FEATURE	CURRENT SETTING
#500	DHCP	ENABLED [DISABLED, ENABLED]
#501	IP ADDRESS	0.0.0.0
#502	SUBNET MASK	0.0.0.0
#503	DEFAULT GATEWAY	0.0.0.0
#504	DNS SERVER #1	0.0.0.0
#505	DNS SERVER #2	0.0.0.0
#507	MACHINE NAME	MB2000HX_14206A
#508	MAC ADDRESS	00:80:F0:14:20:6A
#532	IP FILTERING	DISABLED [DISABLED, ENABLED]
#533	AUTO IP	DISABLED [DISABLED, ENABLED]
#534	HTTPD	ENABLED [DISABLED, ENABLED]
#535	IPv6 PROTOCOL	DISABLED [DISABLED, ENABLED]
#538	WINS SERVER #1	0.0.0.0
#539	WINS SERVER #2	0.0.0.0
#578	ERASE ADDRESS	

FIRMWARE VERSION

GCV1BN

Note:

The above values are the default values.

(KX-MB2010)

SETUP LIST**[BASIC FEATURE LIST]**

NO.	FEATURE	CURRENT SETTING
#101	SET DATE & TIME	01 Jan. 2010 00:00
#110	LANGUAGE	ENGLISH [ENGLISH, CZECH, SLOVAK, HUNGARIAN]
#145	LCD CONTRAST	NORMAL [NORMAL, DARKER]
#147	SCALE	MILLIMETRES [MILLIMETRES, INCHES]
#155	CHANGE PASSWORD	
#158	MAINTENANCE TIME	12:00 Set Value
#159	RESTORE DEFAULT	
#165	BEEP SOUND	ON [OFF, ON]
#380	PAPER SIZE #1	A4 [LETTER, A4, B5 (ISO), B5 (JIS), 16K]
#381	PAPER SIZE #2	A4 [LETTER, A4, LEGAL, B5 (ISO), B5 (JIS), 16K, 216X330, 216X340]
#383	MEDIA TYPE #1	PLAIN PAPER [PLAIN PAPER, THIN PAPER]
#384	MEDIA TYPE #2	PLAIN PAPER [PLAIN PAPER, THIN PAPER]
#403	POWER SAVE	5min [5min, 15min, 30min, 1h]
#462	CONTRAST HOLD	DISABLED [DISABLED, ENABLED]
#482	TONER SAVE	OFF [OFF, ON]

[COPY FEATURE LIST]

NO.	FEATURE	CURRENT SETTING
#460	COPY INPUT TRAY	#1 [#1, #2]
#461	COPY RESOLUTION	TEXT/PHOTO [TEXT/PHOTO, TEXT, PHOTO]
#467	PAGE LAYOUT HOLD	DISABLED [DISABLED, ENABLED]
#468	ZOOM HOLD	DISABLED [DISABLED, ENABLED]
#469	COLLATE HOLD	DISABLED [DISABLED, ENABLED]
#473	EDGE HOLD	DISABLED [DISABLED, ENABLED]
#474	FRAME MARGIN	DISABLED [DISABLED, ENABLED]
#475	MARGIN HOLD	DISABLED [DISABLED, ENABLED]

[PC PRINT FEATURE LIST]

NO.	FEATURE	CURRENT SETTING
#774	DATA TIMEOUT	60s [5...600(s)]
#776	MUTUAL A4/LETTER	ON [OFF, ON]

[SCAN FEATURE LIST]

NO.	FEATURE	CURRENT SETTING
#493	SCAN MODE	VIEWER [VIEWER, FILE, EMAIL, OCR]
#494	SCAN PARAM. HOLD	DISABLED [DISABLED, ENABLED]

[LAN FEATURE LIST]

NO.	FEATURE	CURRENT SETTING
#500	DHCP	ENABLED [DISABLED, ENABLED]
#501	IP ADDRESS	0.0.0.0
#502	SUBNET MASK	0.0.0.0
#503	DEFAULT GATEWAY	0.0.0.0
#504	DNS SERVER #1	0.0.0.0
#505	DNS SERVER #2	0.0.0.0
#507	MACHINE NAME	MB2010HX_14206A
#508	MAC ADDRESS	00:80:F0:14:20:6A
#532	IP FILTERING	DISABLED [DISABLED, ENABLED]
#533	AUTO IP	DISABLED [DISABLED, ENABLED]
#534	HTTPD	ENABLED [DISABLED, ENABLED]
#535	IPV6 PROTOCOL	DISABLED [DISABLED, ENABLED]
#538	WINS SERVER #1	0.0.0.0
#539	WINS SERVER #2	0.0.0.0
#578	ERASE ADDRESS	

FIRMWARE VERSION GCW1BN

Note:

The above values are the default values.

11.3. History (Example of a printed out list)

[HISTORY]

```

Model : MB2030RU Usage Time : 000002
Rom Version(Main) : Ver8.50 Receive Mode : FAX
Check SUM : 0EEA Number of Copy : 000000
Number of Receive : 000000
Number of Send : 000000

Your LOGO :
Your Fax NO :
First Setting Date/Time :
Month : 01 Drum Print Count : 00007
Day : 01 Drum Paddle Count : 00030
Year : 2009 Toner Print Count : 000000
Hour/Minute : 0000 Toner Paddle Count : 000000
Total Print Count : 0000007
Duplex Count : 0000000

Factory to Customer(Day) : 00000
Factory to Now(Day) : 00000
Power On Count : 0000003
    
```

(1)	(2)	(3)	(4)	(5)	(6)
0 0 0 0 0 0	0 0 0 0 0 2	0 0 0 0 0 0	0 0 0 0 0 0	P U L S E	0 0 0 0 0
(7)	(8)	(9)	(10)	(11)	(12)
0 0 0 0 0	0 0 0 0 0 0	0 0 0 0 0 0	0 0 0 0 0 0	0 0 0 0 0 0	0 0 0 0
(13)	(14)	(15)	(16)	(17)	(18)
0 0 0 0 0 0	0 0 0	0 0 0	0 0 0 0	0 0 0 0	0 0 0 0
(19)	(20)	(21)	(22)	(23)	(24)
0 0 0 0	0 0 0 0	0 0 0 0	0 0 0 0	0 0 0 0	0 0 0 0 0 0
(25)		(26)		(27)	
0 0 0 0 0 0		0 0 0 0 0 0		0 0 0 0 0 0	

NAME _____ DATE _____ DEALER _____
 CUSTOMER COMPLAINT _____

SURVEY RESULT : CKOK (UNKNOWN/DESIGN/EDUC) DEFECT (PART/WORKER/DESIGN)
 ABUSE (CUST/DEALER/SHIP) NEW (OPEN/NOT)
 PHONE SURVEY RESULT.

Note:

See the following descriptions of this report. Item No. (1) ~ (27) are corresponding to the listed items in **Descriptions of The History Report** (P.88).

11.3.1. Descriptions of The History Report

- (1) Not used
- (2) Not used
- (3) Dial Mode
- (4) Number of Directory Entry
- (5) Number of Caller ID
- (6) Number of Scan
- (7) Number of ADF Scan (KX-MB2010 ONLY)
- (8) Number of Flatbed Scan
- (9) Number of PC Scan
- (10) Number of Document JAM
- (11) Number of Print
- (12) Number of Warning List
- (13) Number of Help List
- (14) Call Service 3 Information 1
- (15) Call Service 3 Information 2
- (16) Call Service 3 Information 3
- (17) Number of Recording paper JAM
- (18) Number of Pickup Errors in Cassette 1
- (19) Not used
- (20) Not used
- (21) Not used
- (22) Not used
- (23) Not Used
- (24) Not Used
- (25) Number of Copies

12 Troubleshooting Guide

12.1. User Recoverable Errors

If the unit detects a problem, one or more of the following messages will appear on the display. The explanations given in the [] are for servicemen only.

DISPLAY MESSAGE	CAUSE AND REMEDY
CALL SERVICE 1	<ul style="list-style-type: none"> • Polygon motor error. Refer to CALL SERVICE 1 (P.98).
CALL SERVICE 2	<ul style="list-style-type: none"> • Laser beam error. Replace LSU unit. Refer to CALL SERVICE 2 (P.99).
CALL SERVICE 3	<ul style="list-style-type: none"> • Fuser unit cannot heat up. Replace fuser unit. Refer to CALL SERVICE 3 (P.100).
CALL SERVICE 4	<ul style="list-style-type: none"> • Fan motor error. Replace fan motor. Refer to CALL SERVICE 4 (P.101).
CALL SERVICE 5	<ul style="list-style-type: none"> • Print motor error. (only for DC motor) Refer to CALL SERVICE 5 (P.102).
CALL SERVICE 6	<ul style="list-style-type: none"> • Charge unit error (An error occurred in the Charge unit including High voltage unit. (Also the Charger went wrong.)) Refer to CALL SERVICE 6 (P.103).
CHANGE DRUM	<ul style="list-style-type: none"> • There is something wrong with the drum cartridge. Replace the drum cartridge and the toner cartridge.
CHECK DOCUMENT	<ul style="list-style-type: none"> • The document was not fed into the unit properly. Remove the document, and then press [Stop] to clear the message. Re-insert the document. If misfeeding occurs frequently, clean the document feeder rollers and try again.
CHECK DRUM	<ul style="list-style-type: none"> • The drum cartridge is not inserted properly. Re-insert it correctly.
CHECK PAPER #1	<ul style="list-style-type: none"> • Recording paper is not installed or the paper input tray has run out of paper. Install paper. • Recording paper was not fed into the unit properly. Re-insert the recording paper. • The paper input tray is not installed or is not inserted completely. Insert the paper input tray into the unit.
CHECK PAPER TRAY #1	<ul style="list-style-type: none"> • The loaded recording paper is not the appropriate size. Load recording paper of the size that is shown on the display. • If this message is often displayed, also change the recording paper size setting (feature #380). • The recording paper size setting (feature #380) is set to "B5(ISO)", "B5(JIS)" or "16K", so received faxes have been stored into memory. Change the recording paper size setting and load the appropriate recording paper. <p>Note:</p> <ul style="list-style-type: none"> • "#1": Check the paper input tray. The displayed paper size depends on the recording paper size setting (feature #380). • "#2": Check the manual input tray. The displayed paper size depends on the recording paper size setting (feature #381).
CHECK PICK UP INPUT TRAY #2	<ul style="list-style-type: none"> • Recording paper was not fed into the unit properly. Load the paper again.
CHECK REAR COVER	<ul style="list-style-type: none"> • The manual input tray (rear cover) is open. Close it. • A recording paper jam occurred near the manual input tray (rear cover). Remove the jammed paper.
COOL DOWN FUSER	<ul style="list-style-type: none"> • The unit is cooling down the fuser unit. Wait for a while.
DRUM LIFE LOW REPLACE SOON	<ul style="list-style-type: none"> • The drum is reaching the end of its life. Replace the drum cartridge and the toner cartridge as soon as possible.
EMAIL SIZE OVER	<ul style="list-style-type: none"> • When performing scan to email address, the total file size of scanned data exceeded the file size limitation. Divide the document into sections.
FILE SIZE OVER	<ul style="list-style-type: none"> • When performing scan to FTP server or scan to SMB folder, the total file size of scanned data exceeded the file size limitation. Divide the document into sections.
KEEP COPYING	<ul style="list-style-type: none"> • Copying has stopped due to some existing problem (Example: a lack of recording paper or a recording paper jam). See the other displayed message instructions to continue copying.

DISPLAY MESSAGE	CAUSE AND REMEDY
LOW TEMP.	<ul style="list-style-type: none"> The inside of the unit is extremely cold and cannot be operated. Use the unit in a warmer area.
MEMORY FULL	<ul style="list-style-type: none"> When performing memory transmission, the document being stored exceeded the memory capacity of the unit. Send the entire document manually. When making a copy, the document being stored exceeded the memory capacity of the unit. Press [Stop] to clear the message. Divide the document into sections.
MODEM ERROR	<ul style="list-style-type: none"> There is something wrong with the unit's modem.
OUT OF PAPER INPUT TRAY #2	<ul style="list-style-type: none"> Recording paper is not loaded in the manual input tray. Load paper.
PAPER IN TRAY #2	<ul style="list-style-type: none"> The recording paper is installed in the manual input tray.
PAPER JAMMED ↕ OPEN TOP COVER	<ul style="list-style-type: none"> A recording paper jam occurred. Remove the jammed paper.
PC FAIL OR BUSY	<ul style="list-style-type: none"> The cable or the computer power cord is not connected correctly. Check the connections. The software is not running on the computer. Restart the software and try again.
PLEASE WAIT	<ul style="list-style-type: none"> The unit is warming up. Wait for a while.
REMOVE DOCUMENT	<ul style="list-style-type: none"> The document is jammed. Remove the jammed document. Attempted to send or copy a document longer than 600 mm using the automatic document feeder. Press [Stop] to remove the document. Divide the document into two or more sheets and try again (KX-MB2010 Only).
REPLACE DRUM CHANGE SUPPLIES	<ul style="list-style-type: none"> The drum cartridge's service life is finished. Replace the drum cartridge and the toner cartridge immediately.
SCANNER POSITION ERROR	<ul style="list-style-type: none"> There is something wrong with the scanner position. Turn the power switch OFF, then ON. If the problem cannot be solved, contact our service personnel.
TONER EMPTY ↕ CHANGE SUPPLIES	<ul style="list-style-type: none"> The toner is empty. Replace the toner cartridge immediately.
TONER LOW ↕ CHANGE SUPPLIES	<ul style="list-style-type: none"> The toner is reaching the end of its life. You will need to replace the toner cartridge soon.
TOP COVER OPEN	<ul style="list-style-type: none"> The top cover is open. Close it.

12.2. Troubleshooting Details

12.2.1. Outline

Troubleshooting is for recovering quality and reliability by determining the broken component and replacing, adjusting or cleaning it as required. First, determine the problem then decide the troubleshooting method. If you have difficulty finding the broken part, determine which board is broken. (For example: the Main PCB, Sensor PCB, etc.) The claim tag from a customer or dealer may use different expressions for the same problem, as they are not a technician or engineer. Using your experience, test the problem area corresponding to the claim. Also, returns from a customer or dealer often have a claim tag. For these cases as well, you need to determine the problem. Test the unit using the simple check list on **Simple Check List**(P.93). Difficult problems may be hard to determine, so repeated testing is necessary.

12.2.2. Starting Troubleshooting

Determine the symptom and the troubleshooting method.

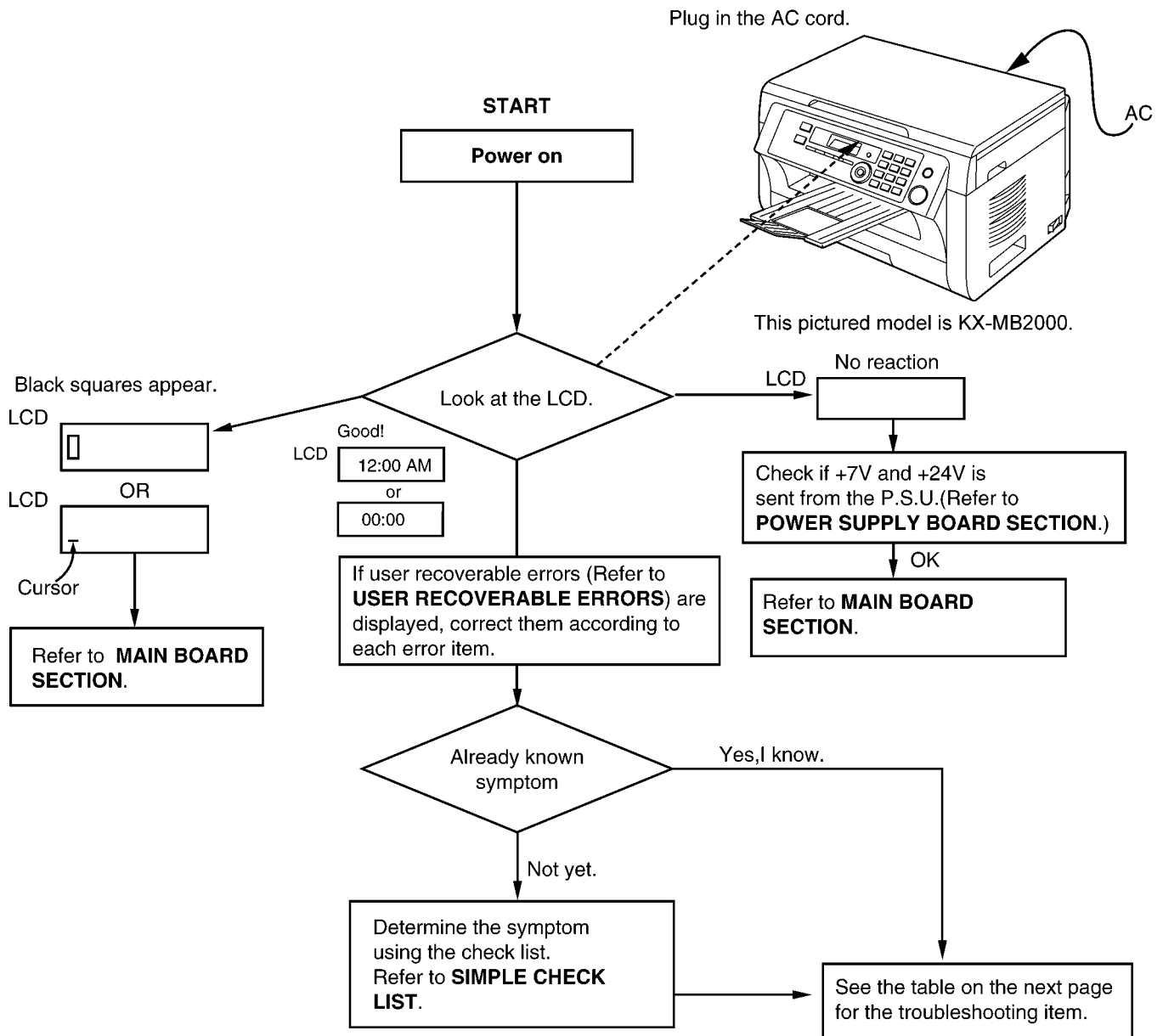

CROSS REFERENCE:

Simple Check List (P.93)

User Recoverable Errors (P.89)

Main Board Section (P.202)

Power Supply Board Section (P.61)

12.2.3. Initialization

There are two types of initialization, one is the short initialization (about 3 seconds) and the other is the long initialization (about 10 seconds). The short initialization makes the unit enter the standby mode. The long initialization makes the unit enter the standby mode after cleaning or detecting the rest of toner.

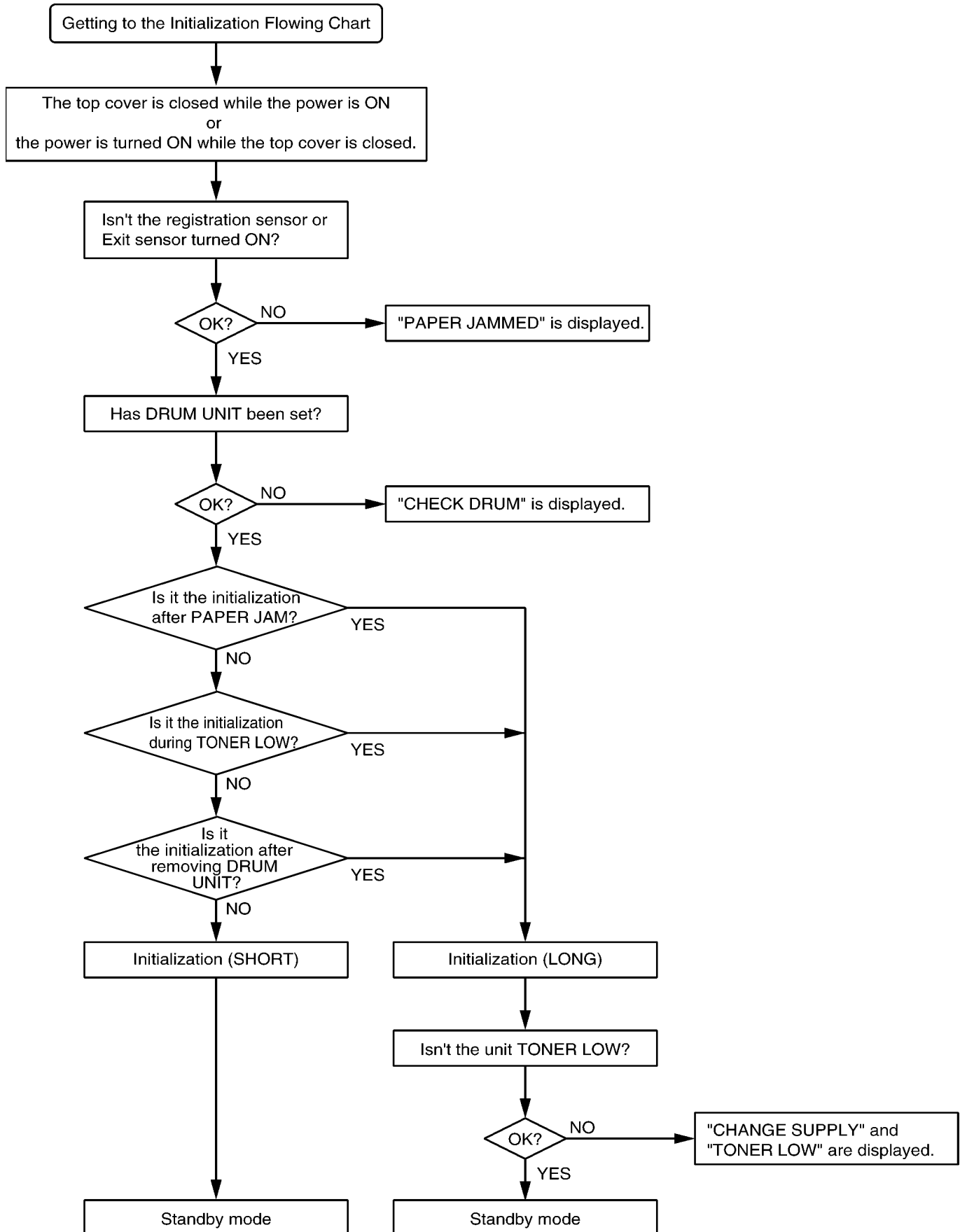

12.2.4. Simple Check List

SERIAL NO. _____ DATE _____

FUNCTION		JUDGEMENT	REFERENCE
Copy operation	Copy by ADF (KX-MB2010 ONLY)	OK / NG	
	Copy by Flat Bed	OK / NG	
PC operation	USB PC print	OK / NG	
	LAN PC print	OK / NG	
Operation panel	Key check	OK / NG	Service code 561*
	LED check	OK / NG	Service code 557*
	LCD check	OK / NG	Service code 558*
Sensor	Sensor check	OK / NG	Service code 815*
Clock		OK / NG	Is the time kept correctly? Check with another clock.

Note:

Check according to the service code referring to **Test Functions** (P.80)

12.2.5. Simplified Troubleshooting Guide

12.2.5.1. Printing

No.	Symptom	Cause	Countermeasure
1	Ghost Image (P.104)	Failed drum cartridge	Replace drum cartridge
		Failed transfer unit	Check the transfer roller and spring
		Failed the high-voltage terminal	Check the high-voltage terminal
		Failed the high voltage power supply board	Go to High Voltage Section (P.134)
		Failed fuser unit	Check the heat roller and the pressurized roller and the spring and the heat lamp and the thermistor
		Too thick or too thin recording paper	Use the recording paper from 16lb to 24lb
2	Dark or White Vertical Line (P.105)	Dirty the cover glass or the reflecting mirror	Clean the cover glass and the reflecting mirror
		Dust on the path of the laser beam	Clean the path of the laser beam
		Failed drum cartridge	Replace drum cartridge
		Failed the heat roller or the pressurized roller	Check the heat roller and the pressurized roller
3	Dark or White Horizontal Line (P.106)	Failed LSU	Go to LSU (Laser Scanning Unit) Section (P.38)
		Failed drum cartridge	Replace drum cartridge
		Failed the gear	Check the gear
		Failed the engine motor	Go to FB (Flatbed) Motor (P.127)
		Failed the high-voltage terminal	Check the high-voltage terminal
		Failed the high voltage power supply board	Go to High Voltage Section (P.134)
		Scratch on the OPC drum	Replace drum cartridge
4	Dirty or Half Darkness Background (P.107)	Static electricity on the documents (when copying)	Check the connection between the parts around CIS and earth
		Failed drum cartridge	Replace drum cartridge
		Dirty the pickup roller and the regist roller and the feed roller and the eject roller and the heat roller and the pressure roller	Clean the pickup roller and the regist roller and the feed roller and the eject roller and the heat roller and the pressure roller
		Failed the high-voltage terminal	Check the high-voltage terminal
		Failed the high voltage power supply board	Go to High Voltage Section (P.134)
		Dirty the recording paper path	Clean the recording paper path
5	Black Print (P.108)	Failed drum cartridge	Replace drum cartridge
		Failed LSU	Go to LSU (Laser Scanning Unit) Section (P.38)
		Failed the high-voltage terminal	Check the high-voltage terminal
		Failed the high voltage power supply board	Go to High Voltage Section (P.134)
		Failed the main board	Go to Main Board Section (P.16)
6	Black Print (P.108) OR Light Print (P.109)	Failed CIS (when copying)	Go to CIS Control Section (P.130)
		Short toner	Supply toner
		Failed drum cartridge	Replace drum cartridge
		Life of drum cartridge is over	Replace drum cartridge
		Dirty the cover glass or the reflecting mirror	Clean the cover glass and the reflecting mirror
		Failed the high-voltage terminal	Check the high-voltage terminal
		Failed the high voltage power supply board	Go to High Voltage Section (P.134)
Failed the main board	Go to Main Board Section (P.16)		
7	Black or White Point (P.110)	Failed CIS (when copying)	Go to CIS Control Section (P.130)
		Failed the developer roller (32mm pitch)	Replace drum cartridge
		Failed the OPC drum (75mm pitch)	Replace drum cartridge
		Failed the heat roller (79mm pitch)	Check the heat roller
		Failed the high voltage power supply board	Go to High Voltage Section (P.134)
		Too thick or too thin recording paper	Use the recording paper from 16lb to 24lb

12.2.5.2. Recording Paper Feed

No.	Symptom	Cause	Countermeasure
1	Multiple Feed (P.110)	Dirty or failed the pickup roller	Clean or replace the pickup roller
		Dirty or failed the pickup rubber	Clean or replace the separation rubber
2	The Recording Paper Is Waved or Wrinkled (P.111)	Dirty the pressure roller or the heat roller	Clean the pressure roller and the heat roller
		Failed the spring of pressure roller	Replace the spring of pressure roller
		Separator of heat roller a check	Replace separator
		Dust on the recording paper path	Clean the recording paper path
		Too thin recording paper	Use the recording paper from 16lb to 24lb
3	Skew (P.112)	Dirty or failed the pickup roller	Clean or replace the pickup roller
		Dirty or failed the pickup rubber	Clean or replace the separation rubber
		Dirty or failed the paper feed roller	Clean or replace the regist roller
		Dust on the recording paper path	Clean the recording paper path
		Failed LSU	Replace LSU
		Over the max capacity of the recording paper	Set up to MAX 250 sheets
		Too thick or too thin recording paper	Use the recording paper from 16lb to 24lb
4	The Recording Paper Does Not Feed (P.113)	Dirty or failed the pickup roller	Clean or replace the pickup roller
		Dirty or failed the pickup rubber	Clean or replace the separation rubber
		Failed the gear	Check the gear
		Failed the solenoid	Check the solenoid
		Failed the engine motor	Go to Motor Section (P.126)
		Failed the pickup sensor lever	Check the pickup sensor lever
		Failed the pickup sensor	Go to Sensor Section (P.123)
5	The Recording Paper Jammed (P.114) "PAPER JAMMED" ON THE LCD	Dirty or failed the pressure roller	Clean or replace the pressure roller
		Dirty or failed the heat roller	Clean or replace the heat roller
		Separator of heat roller a check	Replace separator
		Dust on the recording paper path	Clean the recording paper path
		Failed the paper feed roller	Replace the registration roller
		Failed the pickup sensor lever	Check the pickup sensor lever
		Failed the pickup sensor	Go to Sensor Section (P.123)
		Failed the registration sensor lever	Check the Registration & Manual paper sensor (paper top sensor) lever
		Failed the registration sensor	Go to Sensor Section (P.123)
		Failed the exit sensor	Check the Paper Exit sensor lever
		Too thick or too thin recording paper	Use the recording paper from 16lb to 24lb
Not set the toner bottle	Set toner bottle		
6	Back Side of The Recording Paper Is Dirty (P.116)	Dirty the recording paper path	Clean the recording paper path
		Dirty the pressure roller	Clean the pressure roller
		Dirty the regist roller	Clean the registration roller
		Failed the high-voltage terminal	Check the high-voltage terminal
		Failed the high voltage power supply board	Go to High Voltage Section (P.134)

12.2.5.3. Copy

No.	Symptom	Cause	Countermeasure
1	NO DOCUMENT FEED (No Document Feed, Document Jam and Multiple Document Feed) (P.116) (KX-MB2010 ONLY)	Failed the document sensor lever	Replace the document sensor lever
		Failed the document sensor	Go to Sensor Section (P.123)
		Dirty or failed the separation roller	Clean or replace the separation roller
		Dirty or failed the separation rubber	Clean or replace the separation rubber
	DOCUMENT JAM (No Document Feed, Document Jam and Multiple Document Feed) (P.116) (KX-MB2010 ONLY)	Failed the separation spring	Replace the separation spring
		Dust or scratch on the document paper path	Clean the document paper path
		Failed the gear	Check the gear
		Failed the ADF motor	Go to ADF Motor (KX-MB2010 ONLY) (P.128)
	MULTIPLE DOCUMENT FEED (No Document Feed, Document Jam and Multiple Document Feed) (P.116) (KX-MB2010 ONLY)	Failed the ADF cover open switch lever	Replace the ADF cover open switch lever
		Dirty or failed the separation roller	Clean or replace the separation roller
Dirty or failed the separation rubber		Clean or replace the separation rubber	
2	Skew (ADF) (P.118) (KX-MB2010 ONLY)	Failed the separation spring	Replace the separation spring
		Dust or scratch on the document paper path	Clean the document paper path
		Failed the document feed roller	Replace the document feed roller
3	The Received or Copied Data Is Expanded (P.119) (KX-MB2010 ONLY)	Failed the document guide	Replace the document guide
		Dirty or failed the document feed roller (at ADF)	Clean or replace the document feed roller
		Dirty or failed the separation roller (at ADF)	Clean or replace the separation roller
4	Black or White Vertical Line Is Copied (P.120)	Failed CIS movement (at SG)	Replace the belt or the gear or the shaft or the FB motor
		Dirty or failed the white plate and sheet (2 places)	Clean or replace the white plate and sheet
		Dirty or failed the glass board	Clean or replace the glass board
		The cause of printing	Go to Dark or White Vertical Line (P.105)
5	An Abnormal Image Is Copied (P.121)	Failed CIS	Go to CIS Control Section (P.130)
		Dirty or failed the white plate and sheet (2 places)	Clean or replace the white plate and sheet
		Dirty or failed the glass board	Clean or replace the glass board
		Dirty or failed the document feed roller (at ADF)	Clean or replace the document feed roller
		Dirty or failed the separation roller (at ADF)	Clean or replace the separation roller
		Failed CIS movement (at SG)	Replace the belt or the gear or the shaft or the FB motor
		The cause of printing	Go to Dark or White Vertical Line (P.105)

12.2.6. CALL SERVICE Troubleshooting Guide

Call Service related error is most frequent.

Call Service 1 ----- Polygon doesn't rotate..... Refer to **LSU (Laser Scanning Unit) Section (P.38)**.

- First, listen to the sound. If rotation sound isn't heard, check 24V line, POLON signal and POLCLK signal. If even a little of sound is heard, check XREADY signal.

Call Service 2 ----- Laser isn't output..... Refer to **LSU (Laser Scanning Unit) Section (P.38)**

- This can be judged only by referring to signal. Check 5V line, XHSYNC, XAPC, XVIDEO, XLDON.

Call Service 3 ----- Detection of fixing temperature..... Refer to **Heat Lamp Control Circuit (P.53)**

- *Service mode *655 tells the detection number and 3 latest temperatures of the thermistor. The detection point of the Call Service 3 and the thermistor temperature is displayed. Maximum 3 latest temperatures are displayed showing the newest on the left. [AABB CCDD EEFF] AA, CC and EE show the detection points and BB, DD and FF show their temperature detection points.

00: CALL SERVICE 3 was not occurred.

01: means that the value of AD did not increased by 4 steps or more within 10 sec soon after the heater was turned ON. (thermistor's open detection)

02: means that it did not reach the first stabilizing temperature (170°C: 3Dh) within 50 seconds.

03: means that it did not reach the second stabilizing temperature (205°C: 20h)* within 75 seconds after reaching the first stabilizing temperature (170°C: 3Dh).

04: means that it dropped to -40 deg or below by the temperature control after reaching the second stabilizing temperature (205°C: 20h)*.

05: means that it did not reach the first stabilizing temperature (170°C: 3Dh) within 35 seconds from detection temperature 1 (70°C: DAh).

06: means that it became 235°C: 13h or over during printing.

07: means that during printing the short of the thermistor (AD: 00h) was detected.

08: means that the thermistor's short (AD: 00h) were detected.

09: means that it became 235°C: 13h or over during sleep condition (heater OFF).

*: depend on its printing conditions (room temperature, number of printing, printing paper size etc.).

<Note>

Once "CALL SERVICE3" is displayed, it does not disappear until the Factory Setup or Service Function #529 is executed. Therefore Service Function #529 should not be executed before the confirmation, and #529 should be done after the countermeasure.

Call Service 4 ----- Rotation of Fan..... Refer to **FAN Motor Section (P.34)**

- Connector isn't inserted firmly, dust is caught in and the fan is broken.
- Rotation of the Fan can be confirmed by following Test Mode.

Service mode *677

:1... Normal operation (default)

:2... Right Fan & Left Fan ON (High speed)

:3... Right Fan & Left Fan ON (Low speed)

:4... Both Fan OFF

Call service 5 ----- Rotation of Engine motor..... Refer to **Motor Drive Section (P.26)**

- Engine motor's rotation detection signal LD did not become Low within rated speed $\pm 6.25\%$.
- Service mode *556: the operation of Main Motor can be checked by pressing 0 and SET buttons.

Call service 6 ----- Detection of Charger error..... Refer to the **HVPS (High Voltage Power Supply) Section (P.51)**

- Breaking of charger's wire of drum cartridge and/or loose connection of High voltage terminals (CHRG, GRID).
- First, replace the drum cartridge even so, it doesn't function check the high voltage power supply.

* As for Call Service 1, 2, 4, 5 and 6, turn the power OFF then ON to restart.

12.2.6.1. CALL SERVICE 1

"CALL SERVICE 1" means that the polygon motor inside the LSU does not rotate.
 The rotation of the polygon motor is detected by IC300-F23pin (NREADY).

After the LCD indicates "CALL SERVICE 1 ", turn the power OFF/ON.
 Then, when the unit starts initial operation, confirm that the rotating sound of the polygon motor is heard before the engine motor starts to run.

* You can check the LSU function by service mode *639.

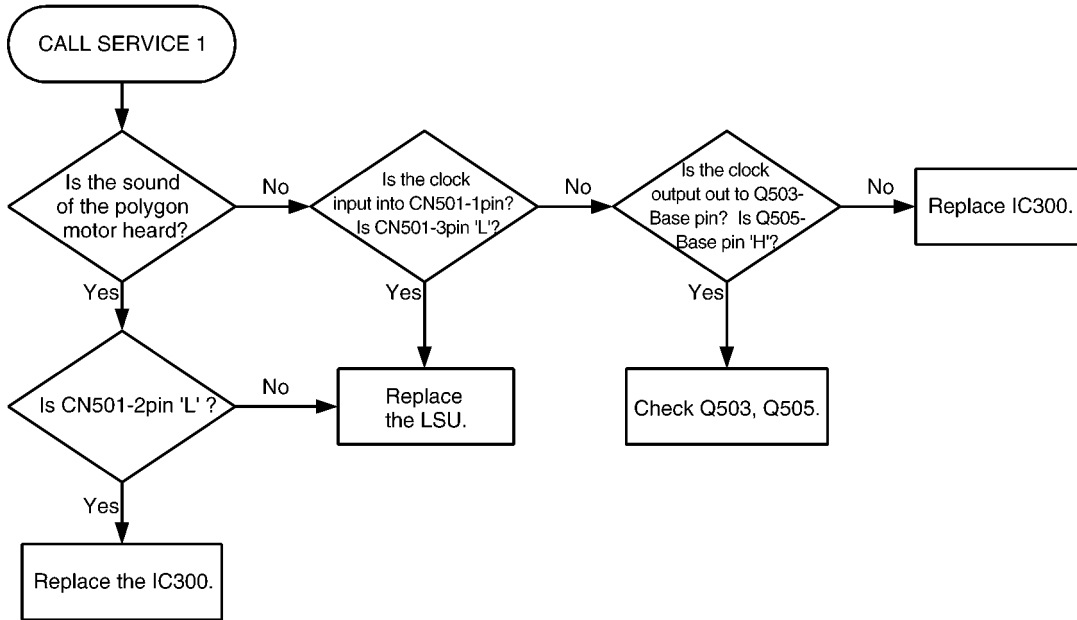

12.2.6.2. CALL SERVICE 2

"CALL SERVICE 2" means that the synchronous signal out of the LSU cannot be detected.
 The synchronous signal out of the LSU is detected by IC 300-G23pin. (NHSYNC)

After the LCD indicates "CALL SERVICE 2", turn the power OFF/ON, then confirm the waveform when the unit starts initial operation.

* You can check the LSU function by service mode ✕639.

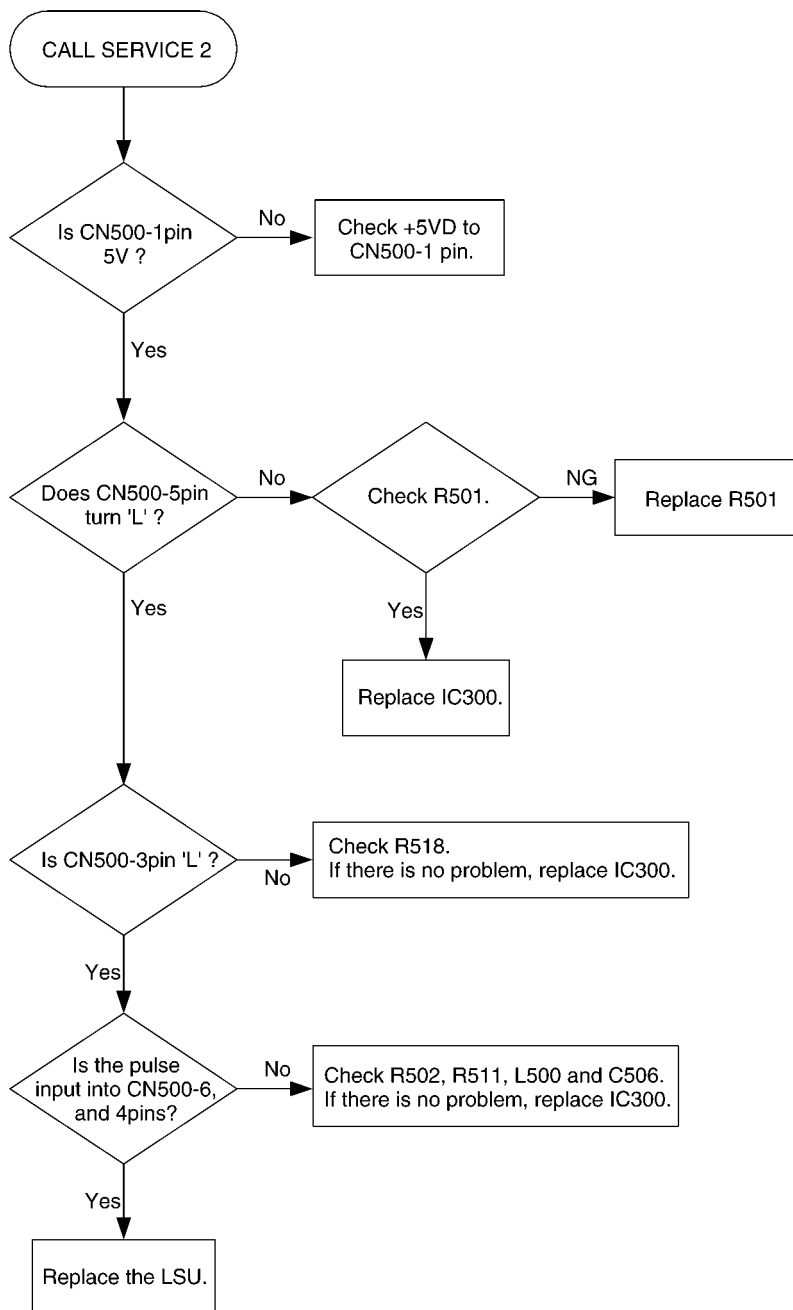

Note:

As for the "Pulse" waveform of the above flow chart, see the timing chart.

12.2.6.3. CALL SERVICE 3

"CALL SERVICE 3" means that the temperature of the fuser does not rise up to or exceed a constant temperature. The temperature is monitored with the thermistor inside the fuser and detected with the voltage input into IC 300-D19.

After the LCD indicate "CALL SERVICE 3" , perform the MENU → # → 9000 → * 529. Then, turn the power OFF/ON. Perform the SENSOR TEST in service mode. SENSOR TEST can be performed by pressing MENU → # → 9000 → *815. In this state, perform the copy operation to confirm how the two-digit numbers on the LCD change. In normal times, 'F9h(25°C)' is displayed in the waiting state, and '20h(205°C)' or its approximate numbers are displayed during printing.

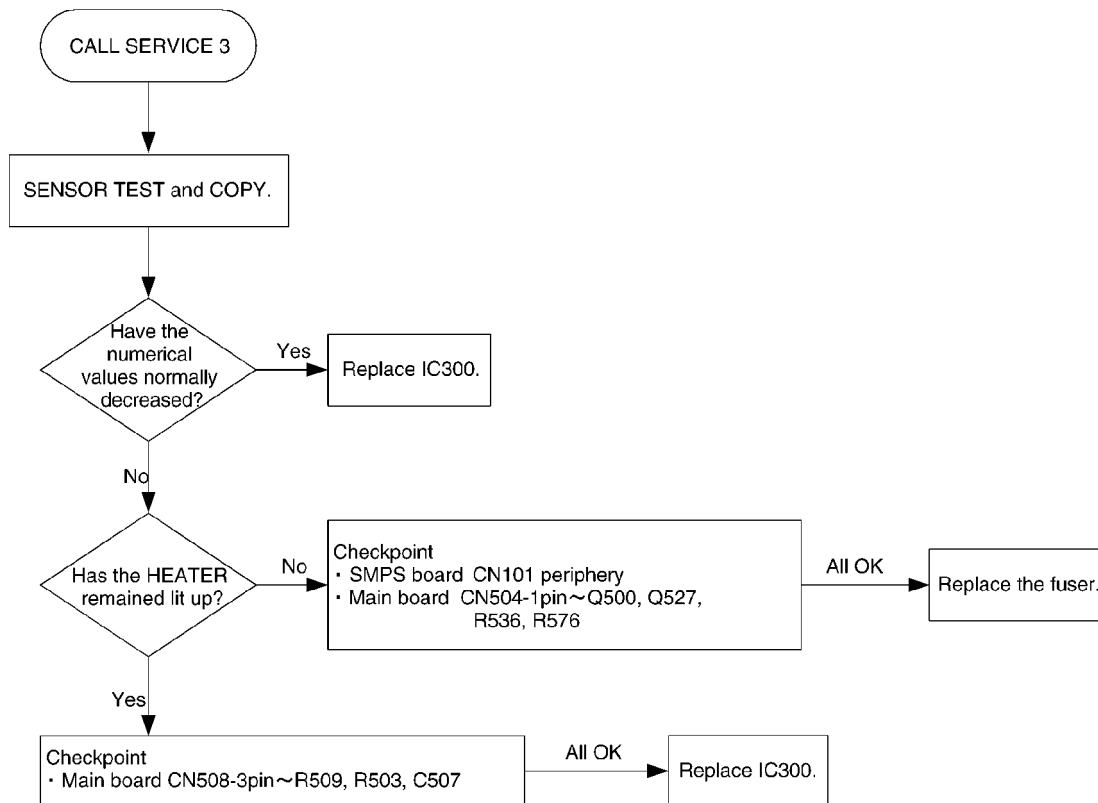

* When Call Service 3 is occurred, the cause can be distinguished by service mode *655. Refer to **CALL SERVICE Troubleshooting Guide (P.97)** for details.

12.2.6.4. CALL SERVICE 4

"CALL SERVICE 4" means that the FAN does not run or the running of the FAN cannot be detected normally.

The running of the FAN is detected by IC300-AC20 and W24pin. "CALL SERVICE 4" is displayed when it detects NG three times continuously.

After repairing, copy three times.If "CALL SERVICE 4 " is displayed, check again.

After the LCD indicates "CALL SERVICE 4 ", turn the power OFF/ON.
 Then, perform the FAN TEST in service mode.
 This can be performed by pressing MENU→#→9000→*677.
 1: Normal operation (Default)
 2: Right FAN & Left FAN: ON (High Speed)
 3: Right FAN & Left FAN: ON (Low Speed)
 4: Both FAN: OFF

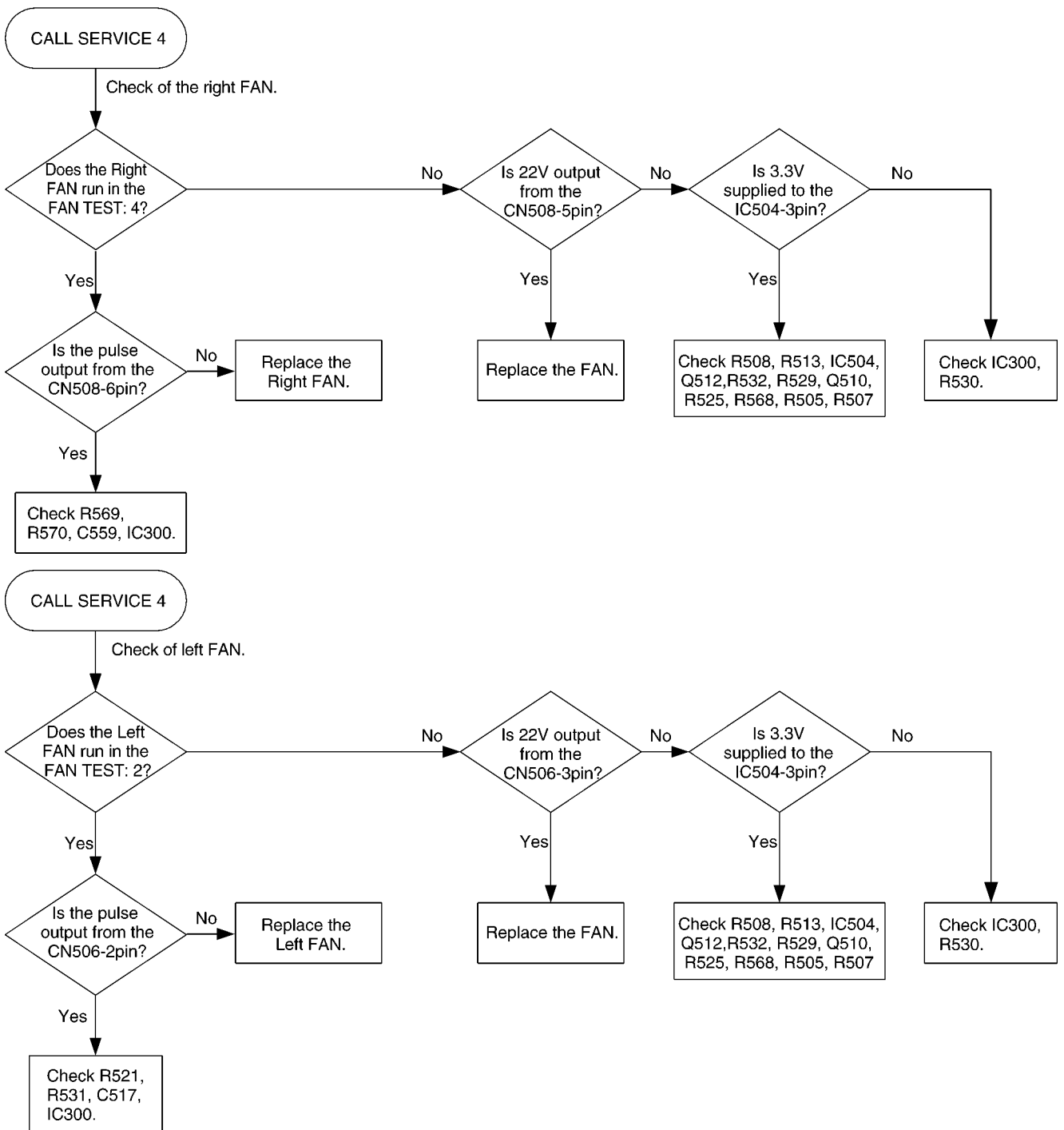

12.2.6.5. CALL SERVICE 5

“CALL SERVICE 5” means that Engine DC motor’s rotation detection signal (LD) does not become Low.

After the LCD indicates "CALL SERVICE 5", turn the power OFF/ON.
 Perform the MOTOR TEST in service mode.
 MOTOR TEST can be performed by pressing MENU → # → 9000 → *556.
 And Press 0 and SET buttons.

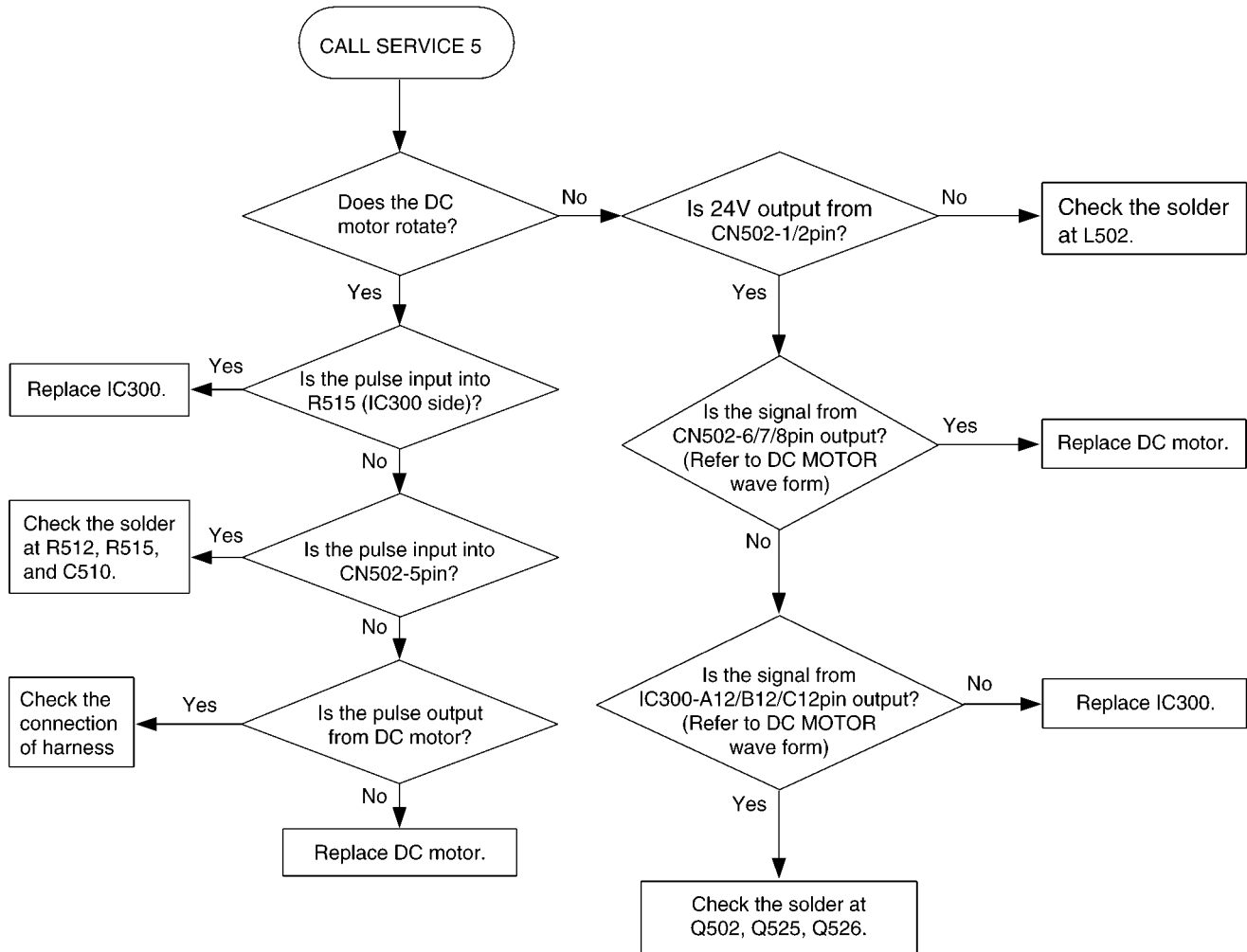

12.2.6.6. CALL SERVICE 6

“CALL SERVICE 6” indicates that abnormal charge voltage is output from the high voltage unit.

CALL SERVICE 6 appears when the charge voltage turns into abnormal voltage caused by charge wire breaking, short circuit, defect, and contact failure between Drum unit and main frame through charge and GRID terminals. When the charge voltage becomes abnormal, the high voltage unit shuts off the charge output, and then trouble detection signal (HVERR) is output from pin 2 of CN1. When the main PCB detects the trouble detection signal, the unit displays CALL SERVICE 6. CALL SERVICE 6 is canceled by turning the power OFF then ON. (When the problem is not solved, CALL SERVICE 6 will be displayed again.)

Confirming the contact points of the main frame

- Check the dirt on the high voltage terminals.
- Check if the spring pressure of each high voltage terminal is strong enough. (Isn't it distorted or bent?)
- When a Drum unit is installed on the main frame, are the terminals connected to the main frame surely?

Confirming the Drum unit (In case that replacement of the development unit caused CALL SERVICE 6 to appear again.)

- Check if the charge wire has breaking, loose, or dirt, etc.
- In case that the dirt is found on the charge wire, does the unit become normal after getting rid of the dirt?

The charge wire should be cleaned with a soft cloth soaked in ethanol. Be careful not to cut the wire.

- Are the contact terminals of Drum unit clean?

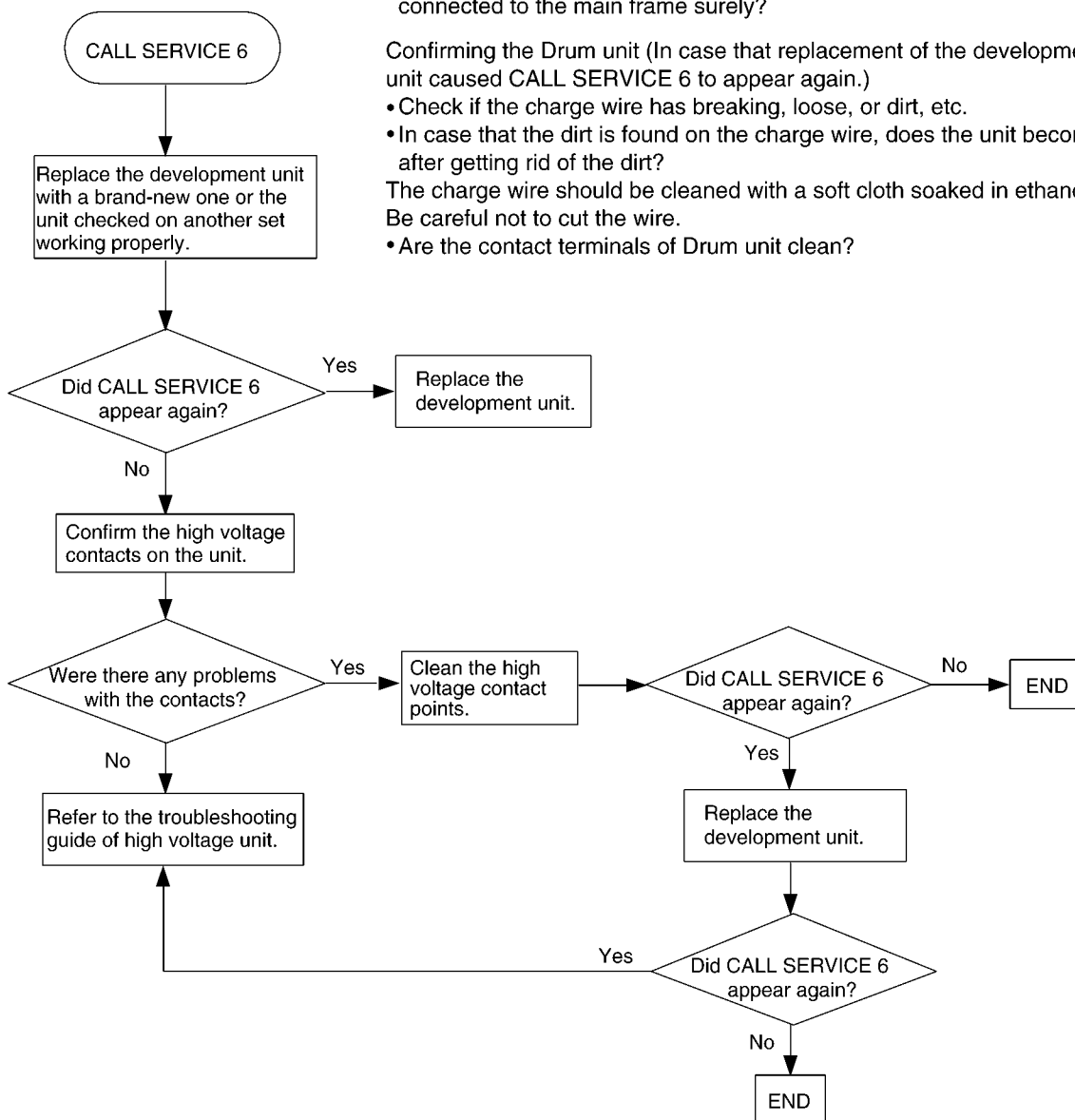

12.2.7. Print

12.2.7.1. Ghost Image

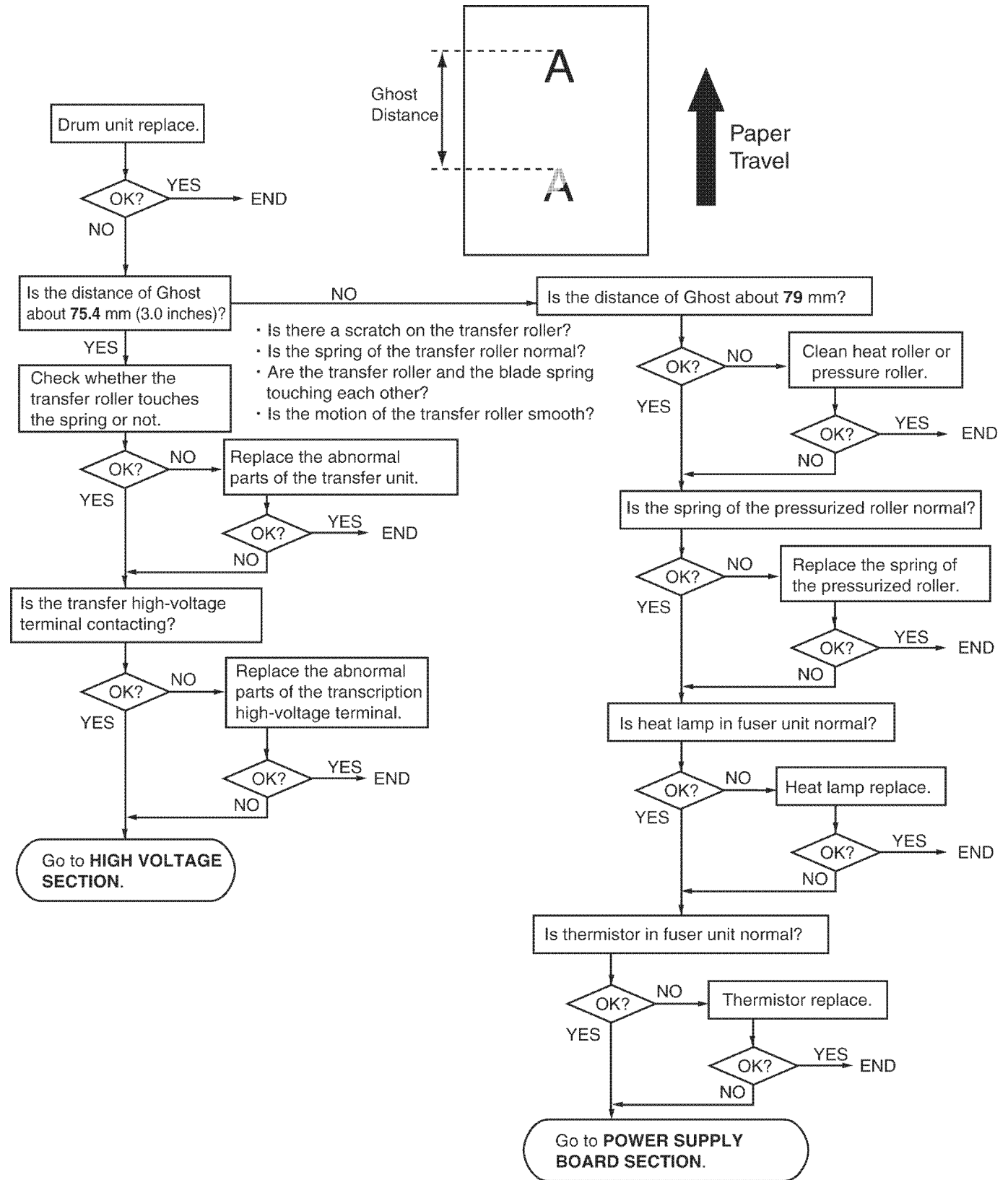

CROSS REFERENCE:

High Voltage Section (P.134)

Power Supply Board Section (P.61)

12.2.7.2. Dark or White Vertical Line

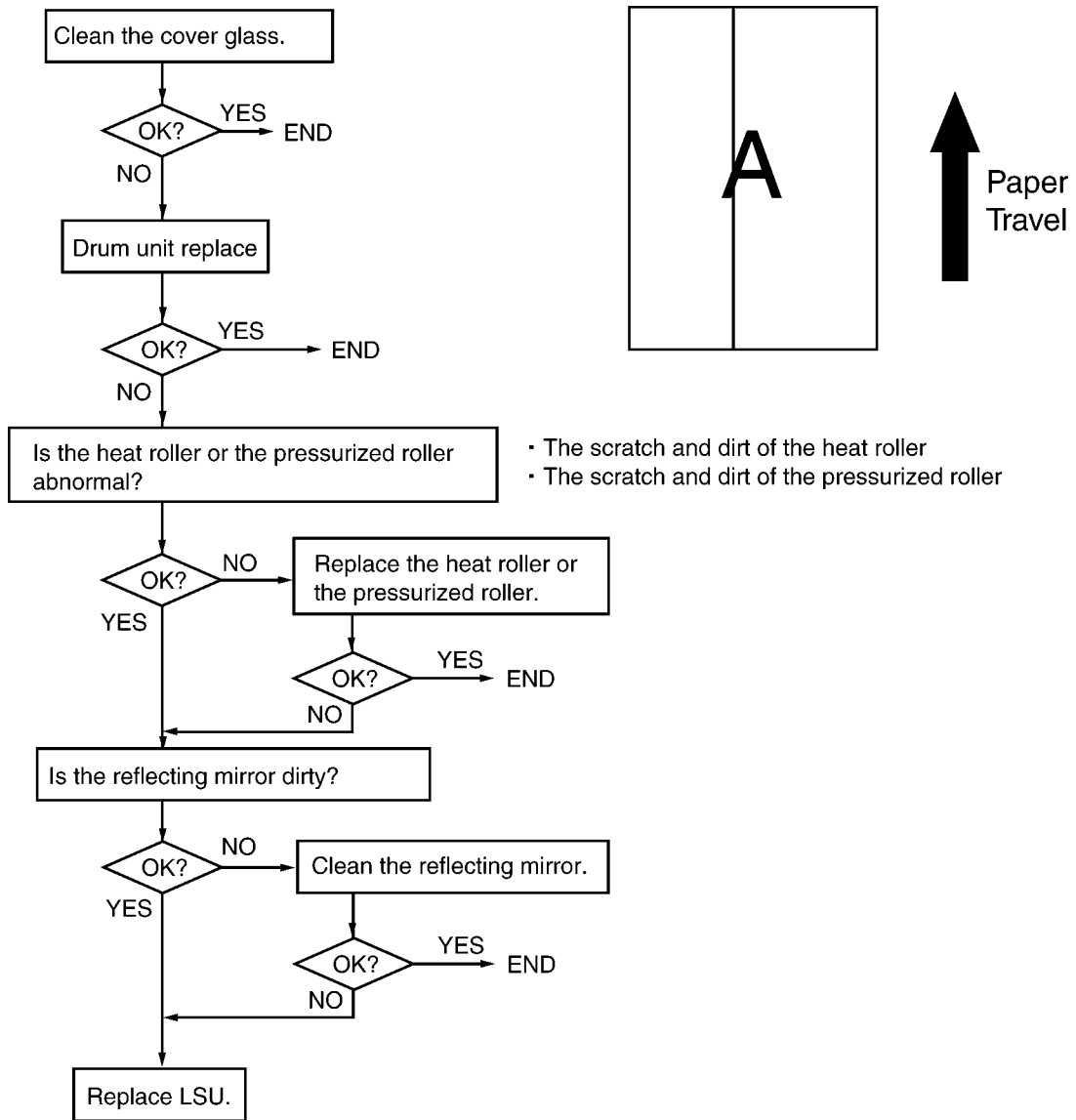

Note:
When wiping the cover glass, reflecting mirror, use a dry and soft cloth.

12.2.7.3. Dark or White Horizontal Line

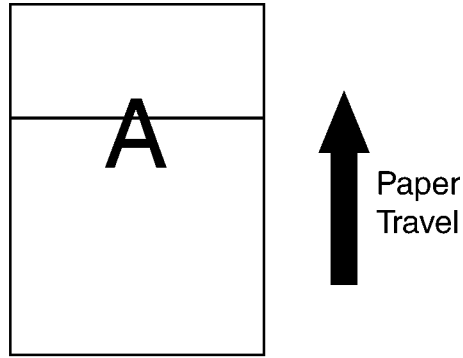
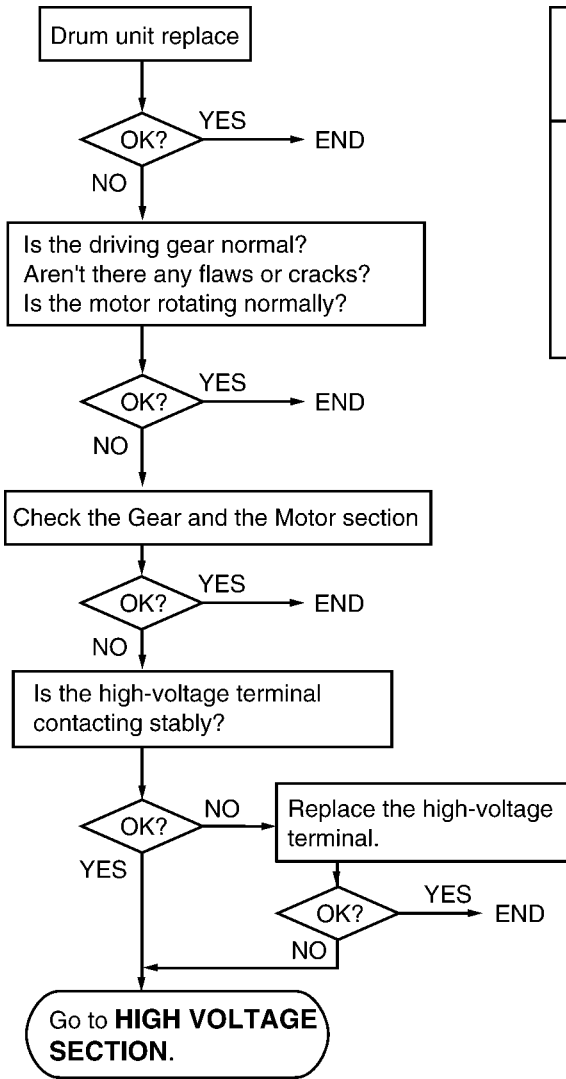

• It is necessary to describe the information about the lines that cannot be troubleshot in such as halftone.
 • When there is the information about the troubleshot horizontal line, please add the description of it.

CROSS REFERENCE:
High Voltage Section (P.134)

12.2.7.4. Dirty or Half Darkness Background

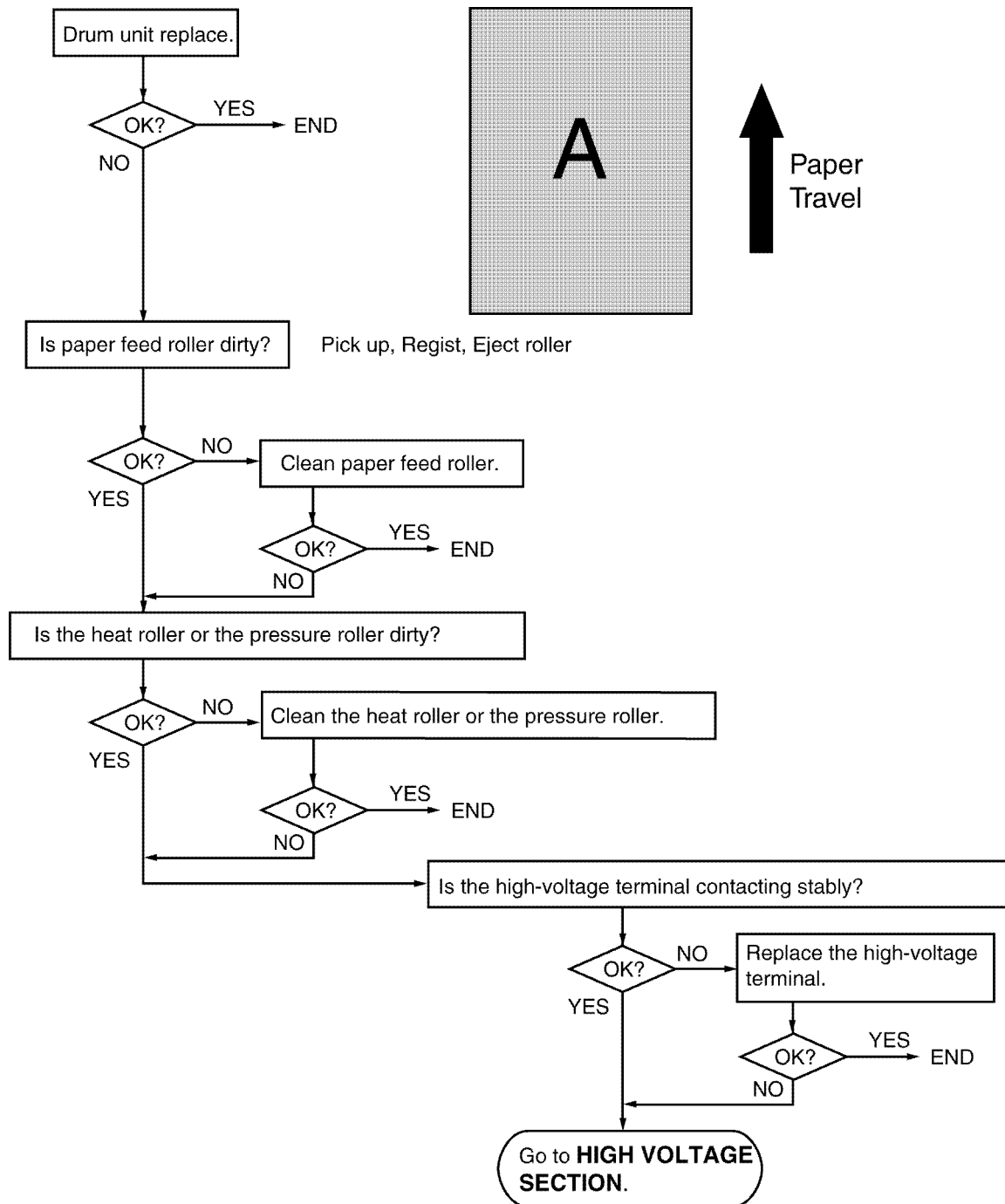

CROSS REFERENCE:
High Voltage Section (P.134)

12.2.7.5. Black Print

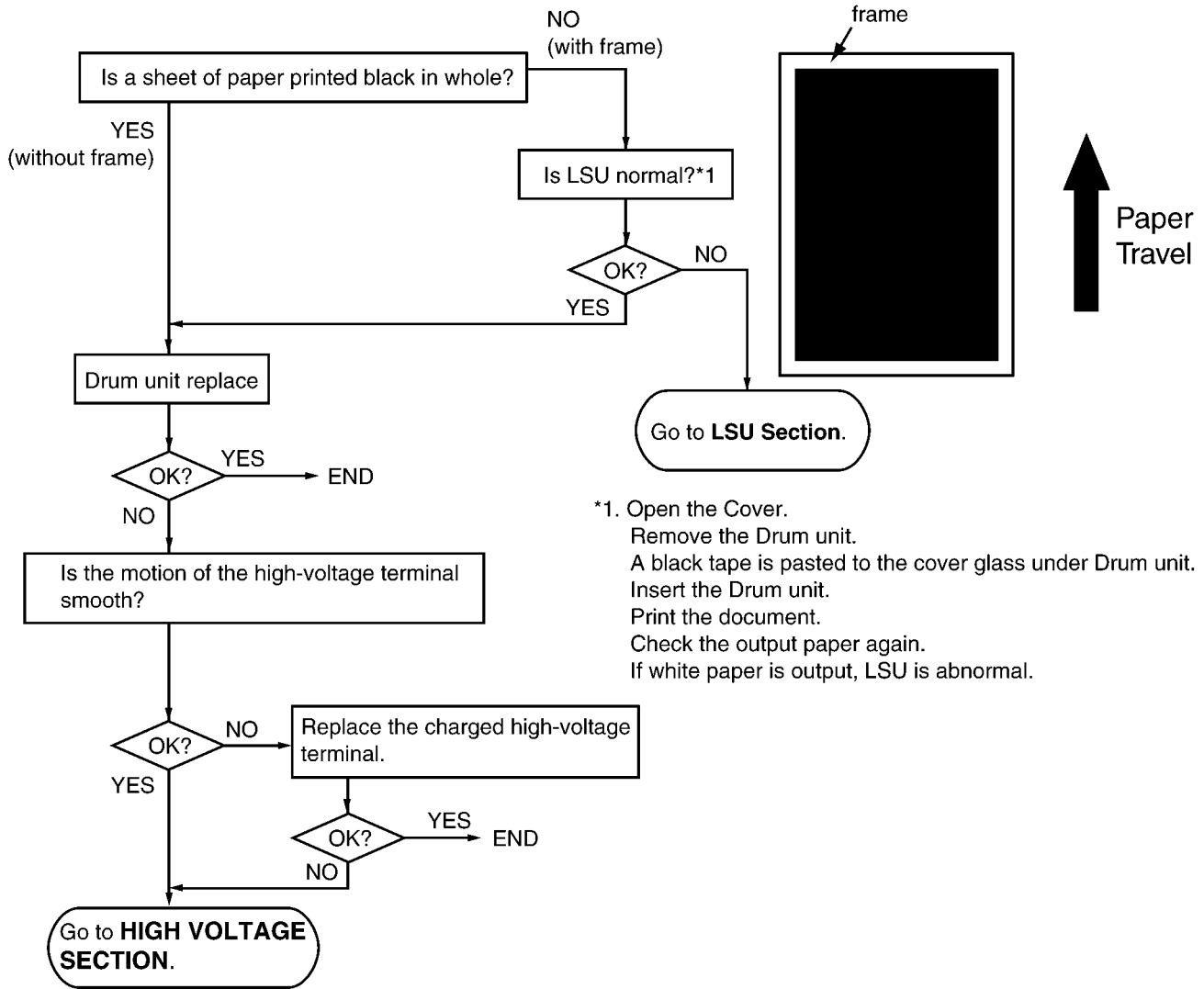

*1. Open the Cover.
 Remove the Drum unit.
 A black tape is pasted to the cover glass under Drum unit.
 Insert the Drum unit.
 Print the document.
 Check the output paper again.
 If white paper is output, LSU is abnormal.

CROSS REFERENCE:
 High Voltage Section (P.134)
 LSU (Laser Scanning Unit) Section (P.38)

12.2.7.6. Light Print

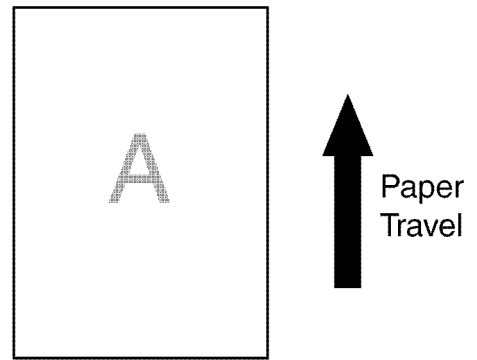
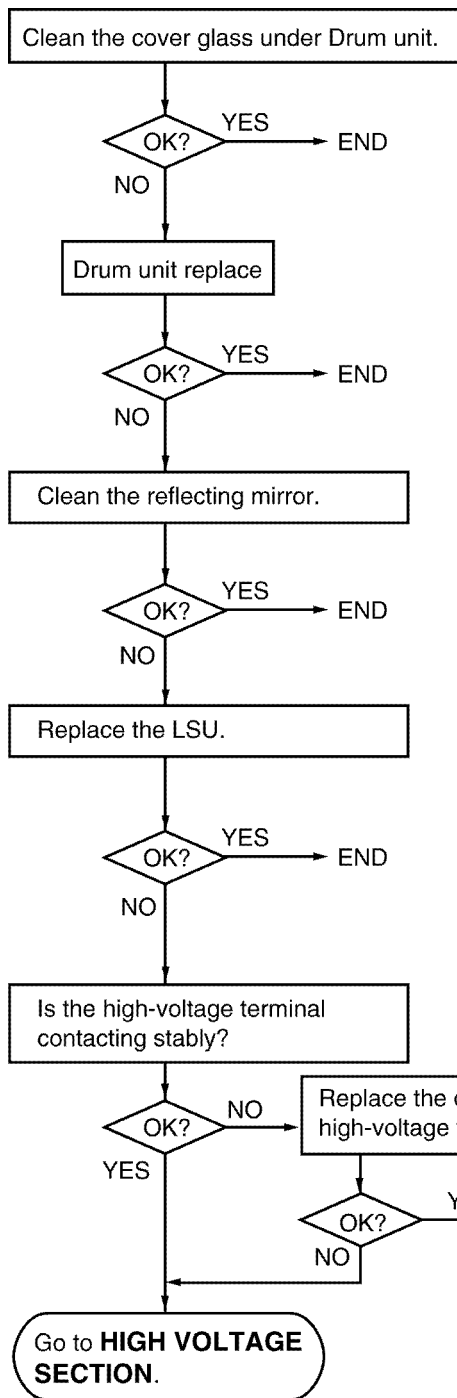

CROSS REFERENCE:
 High Voltage Section (P.134)

12.2.7.7. Black or White Point

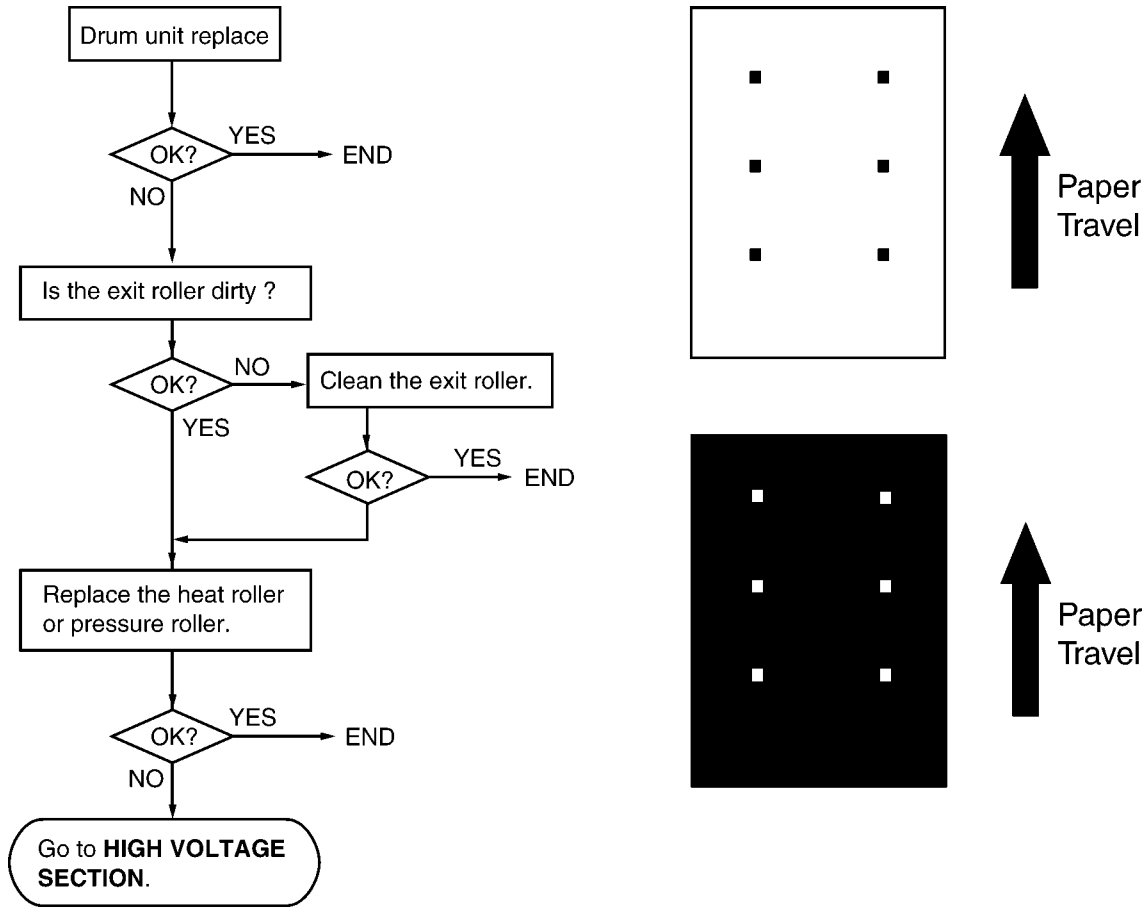

12.2.8. Recording Paper Feed

12.2.8.1. Multiple Feed

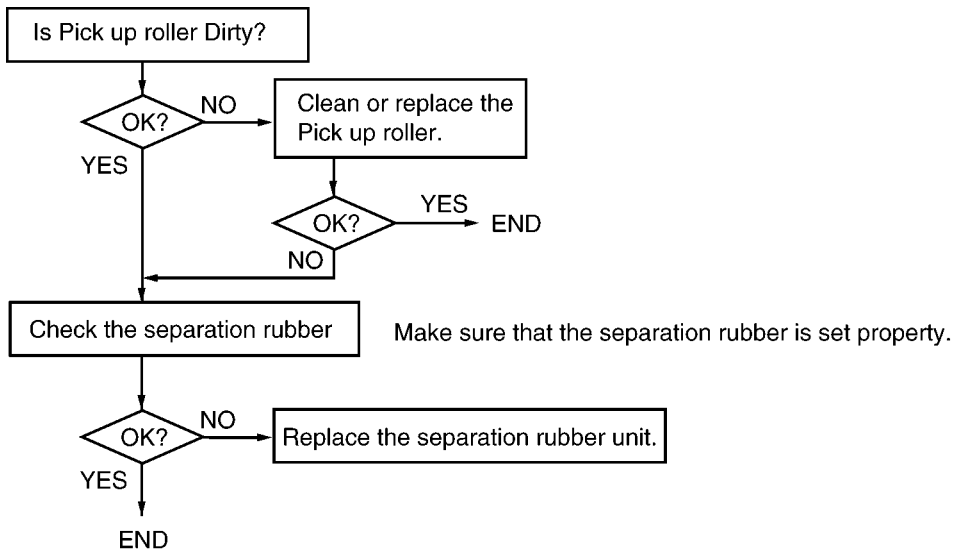

12.2.8.2. The Recording Paper Is Waved or Wrinkled

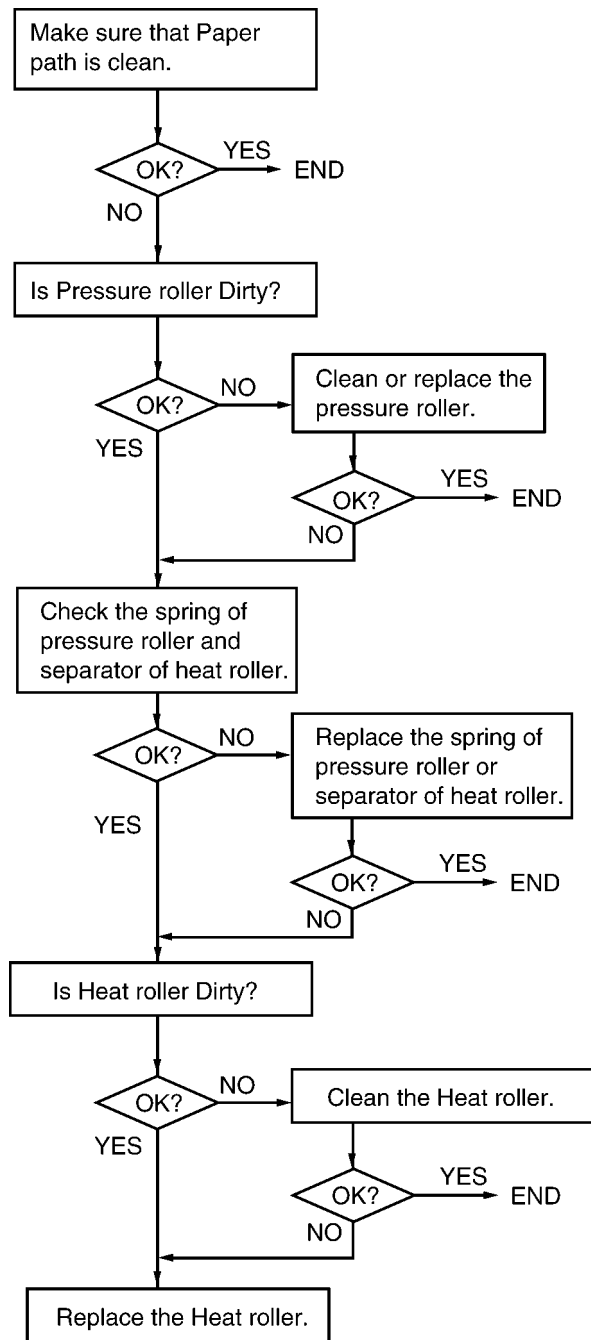

12.2.8.3. Skew

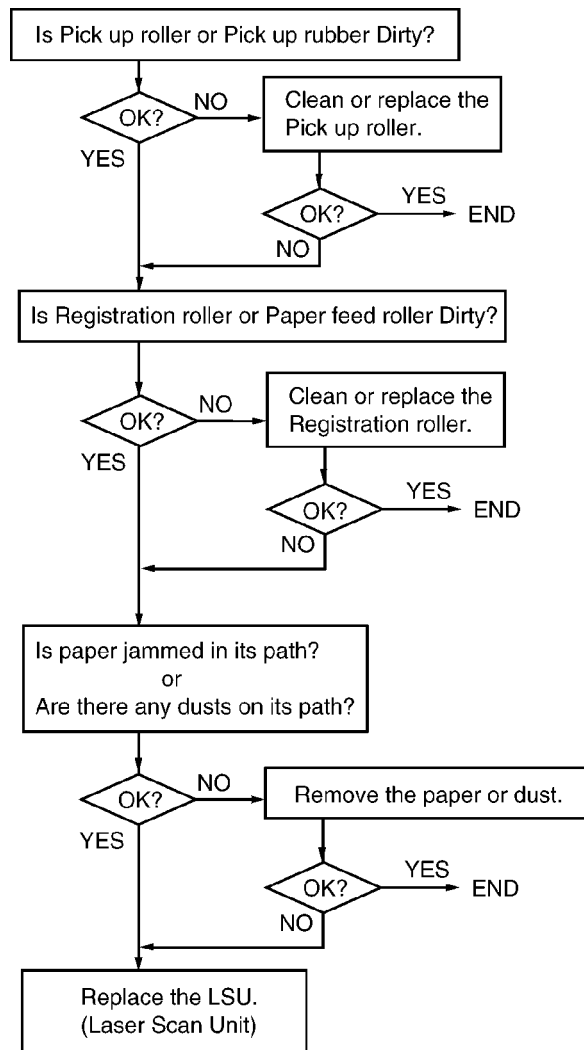

12.2.8.4. The Recording Paper Does Not Feed

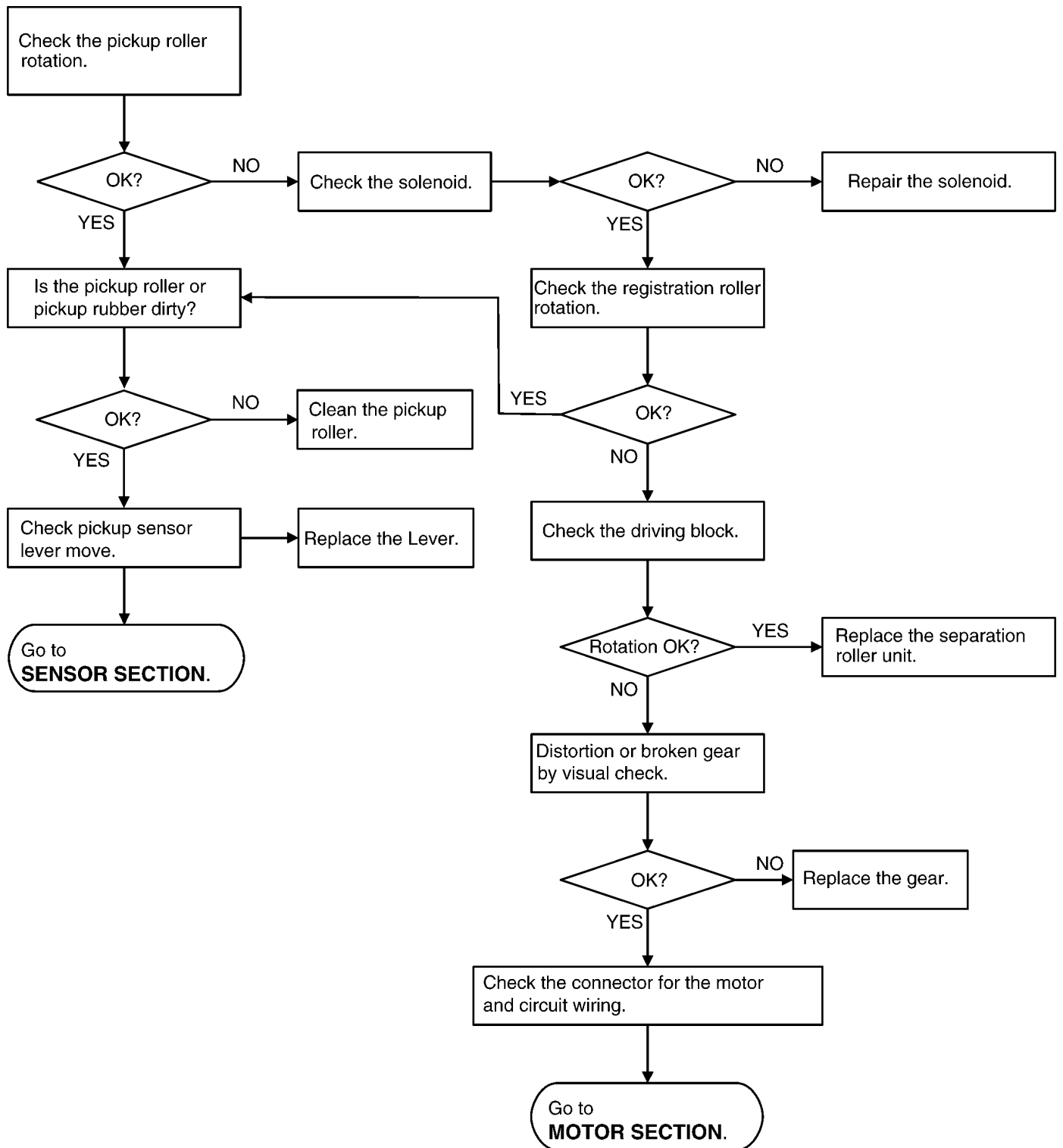

CROSS REFERENCE:
Sensor Section (P.123)
Motor Section (P.126)

12.2.8.5. The Recording Paper Jam

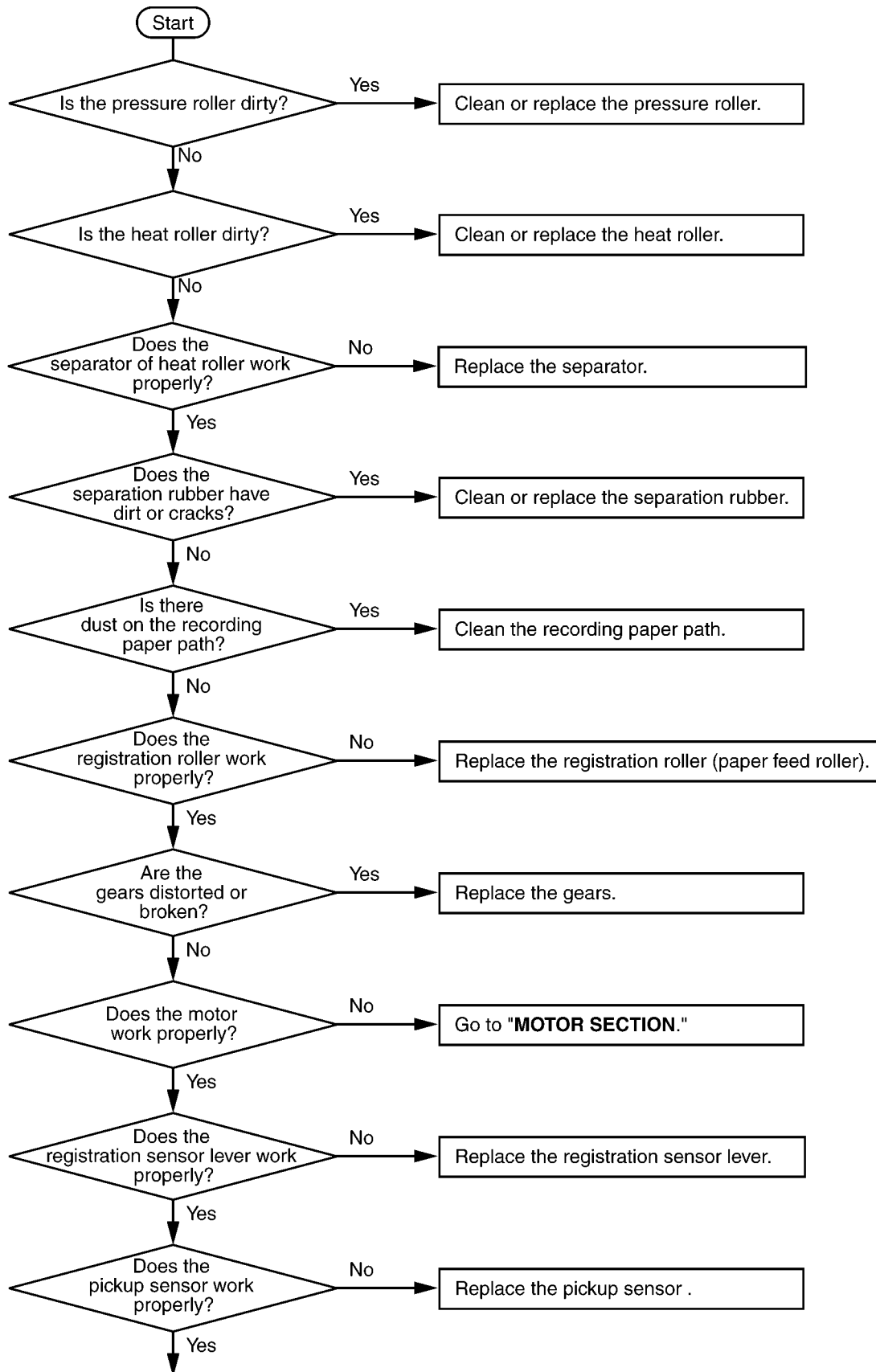

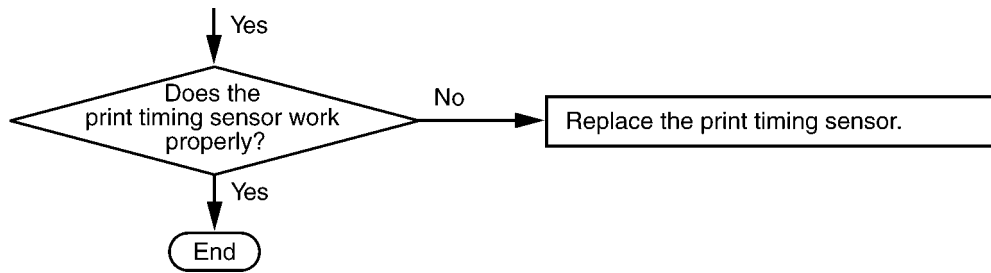
**CROSS REFERENCE:****FAN Motor Section (P.34)**

When the recording paper jam is occurred, the service mode *630 distinguishes the cause.

0:No Jam

1:Exit Sensor turns ON, though not under the conditions for ON.

2:Exit Sensor turns OFF, though not under the conditions for OFF.

3:After Exit Sensor falls, it turns ON already on terminating of Cancel Timer.

4:After Exit Sensor rises, it turns ON already on terminating of Cancel Timer.

5:Top Sensor turns ON, though not under the conditions for ON.

6:Top Sensor turns OFF, though not under the conditions for OFF.

7:After Top Sensor falls, it turns ON already on terminating of Cancel Timer.

8:After Top Sensor rises, it turns OFF already on terminating of Cancel Timer.

9:Exit Sensor never turns ON in the specified time, though Top Sensor turns ON.

10:Top Sensor MAX-length-JAM.

11:Exit Sensor never turns OFF in the specified time, though Top Sensor turns OFF.

12:Registration Sensor turns ON, though not under the conditions for ON.

13:Registration Sensor turns OFF, though not under the conditions for OFF.

14:After Registration Sensor falls, it turns ON already on terminating of Cancel Timer.

15:After Registration Sensor rises, it turns OFF already on terminating of Cancel Timer.

16:Top Sensor never turns ON in the specified time, though Registration Sensor turns ON.

17:Registration Sensor MAX-length-JAM.

18:Top Sensor never turns OFF in the specified time, though Registration Sensor turns OFF.

Top Sensor never turns OFF in the specified time, though Pick1 Sensor turns OFF.

19:PICK1 Sensor turns ON, though not under the conditions for ON.

20:PICK1 Sensor turns OFF, though not under the conditions for OFF.

21:After PICK1 Sensor falls, it turns ON already on terminating of Cancel Timer.

22:After PICK1 Sensor rises, it turns OFF already on terminating of Cancel Timer.

23:Registration Sensor never turns ON in the specified time, though PICK1 Sensor turns ON.

Top Sensor never turns ON in the specified time, though PICK1 Sensor turns ON.

24:PICK2 Sensor MAX-length-JAM.

25:Registration Sensor never turns OFF in the specified time, though PICK1 Sensor turns OFF.

90:Abnormal stop during printing DMA.

91:Incompleteness of JBIG decompression.

92:HVERR(error of an abnormal charge voltage) was detected during printing.

99:Before Motor Rotation.

12.2.8.6. Back Side of The Recording Paper Is Dirty

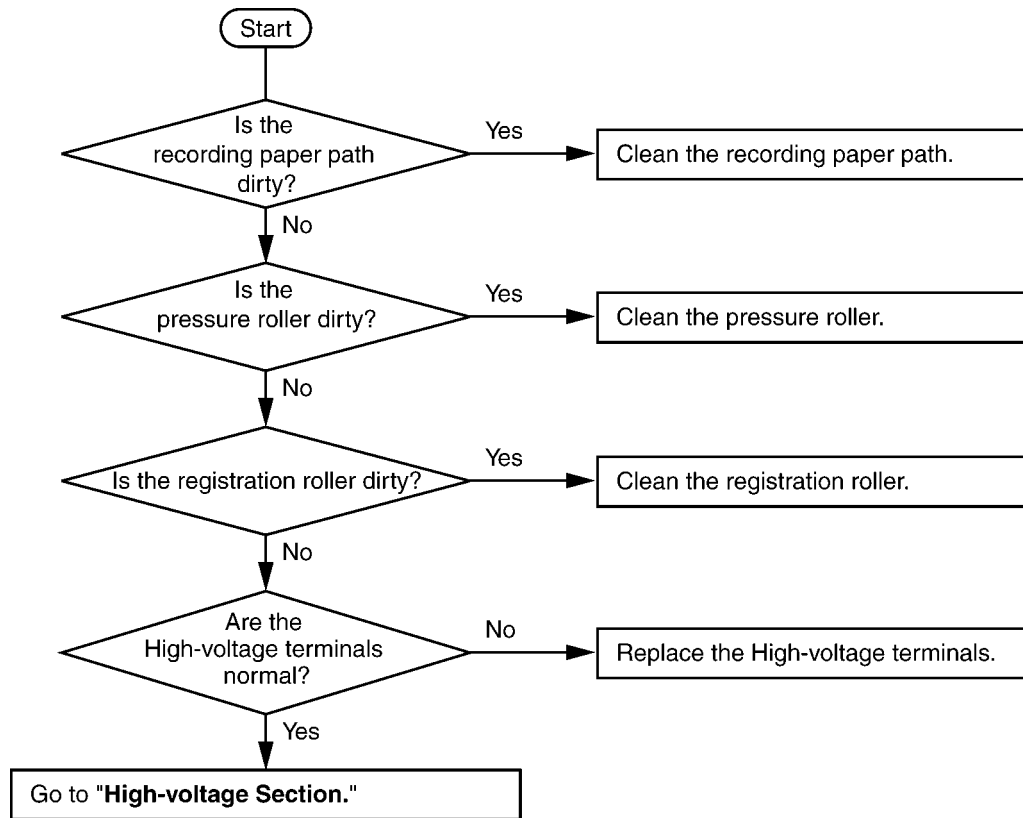

CROSS REFERENCE:
High Voltage Section (P.134)

12.2.9. ADF (Auto Document Feeder) Section (KX-MB2010 ONLY)

12.2.9.1. No Document Feed, Document Jam and Multiple Document Feed

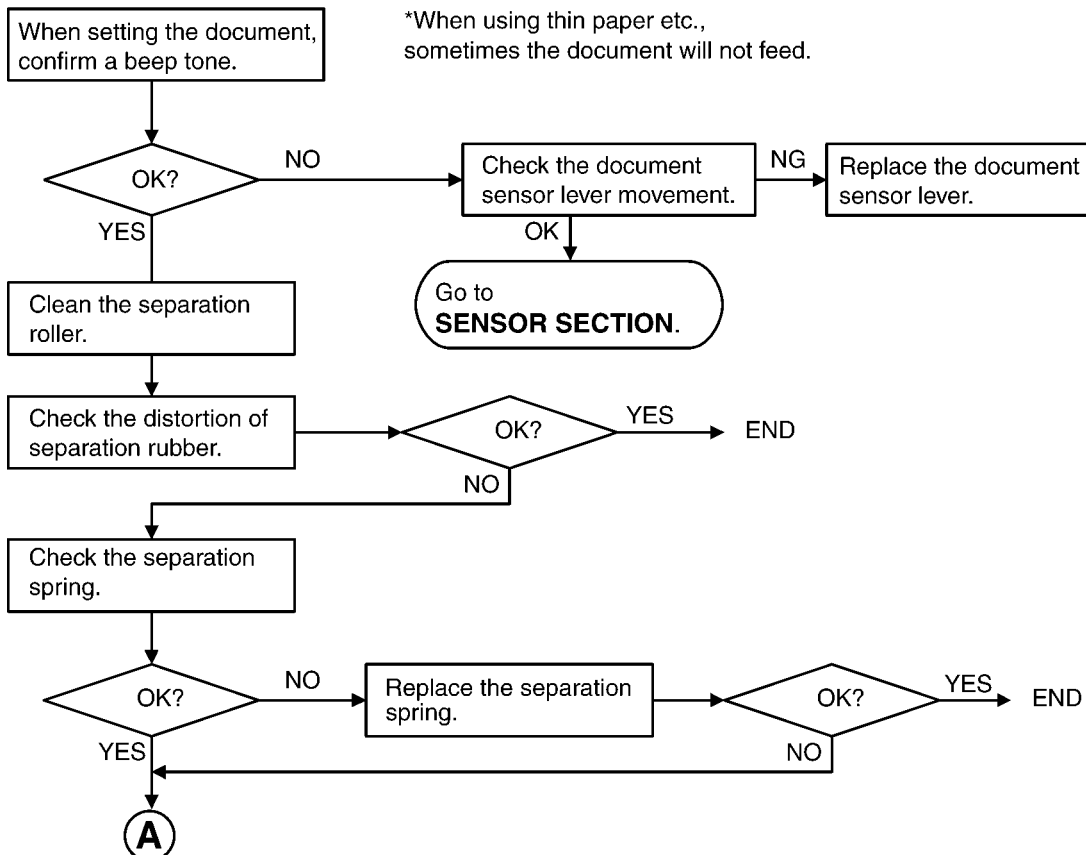

CROSS REFERENCE:
Sensor Section (P.123)

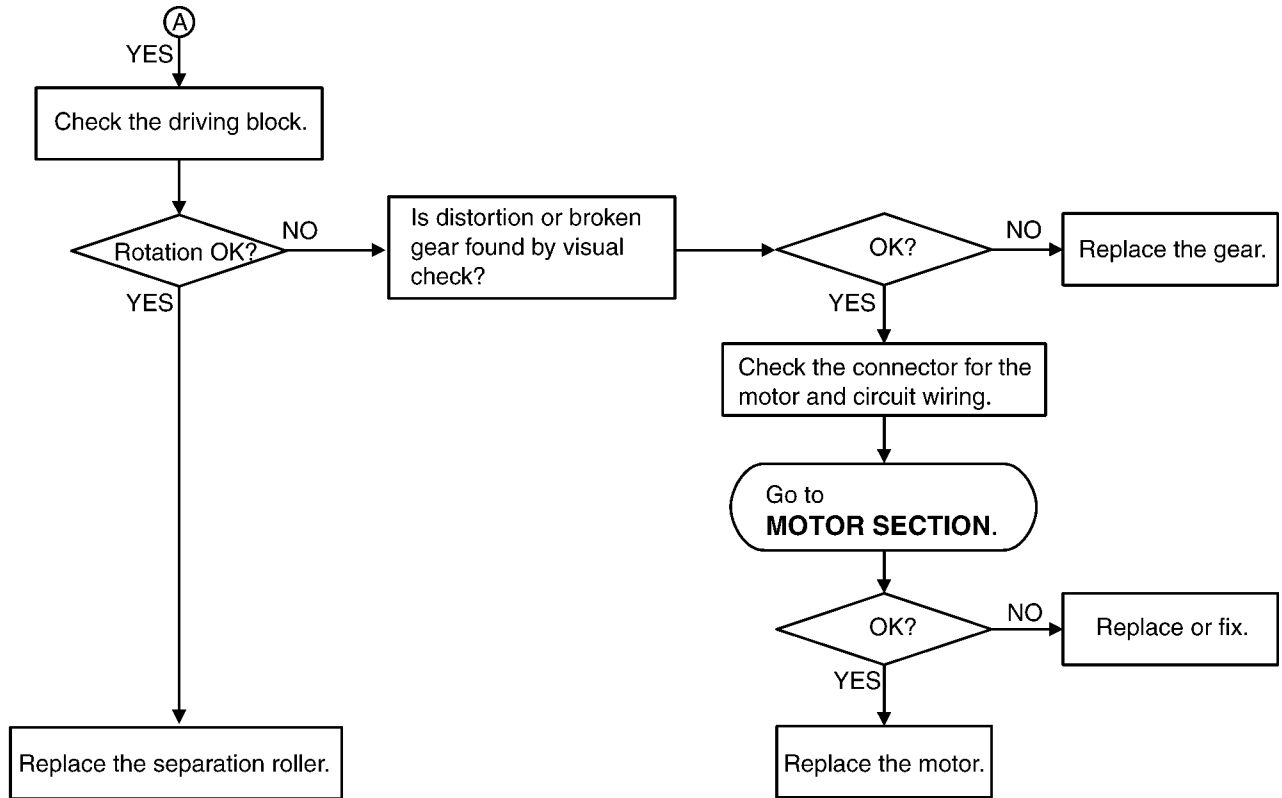

Depending on the circumstances, change the roller, one-way spring gear, etc., as well as the other rollers or parts.

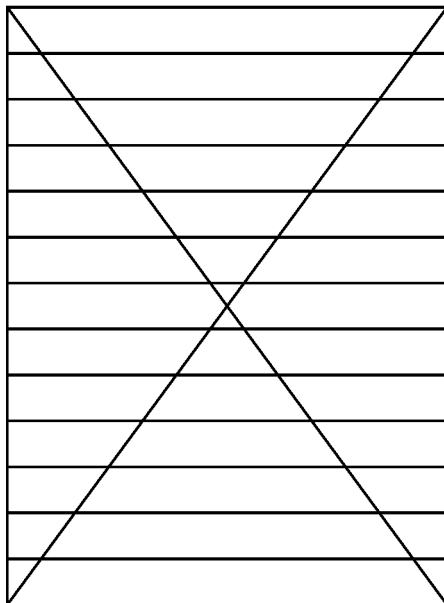
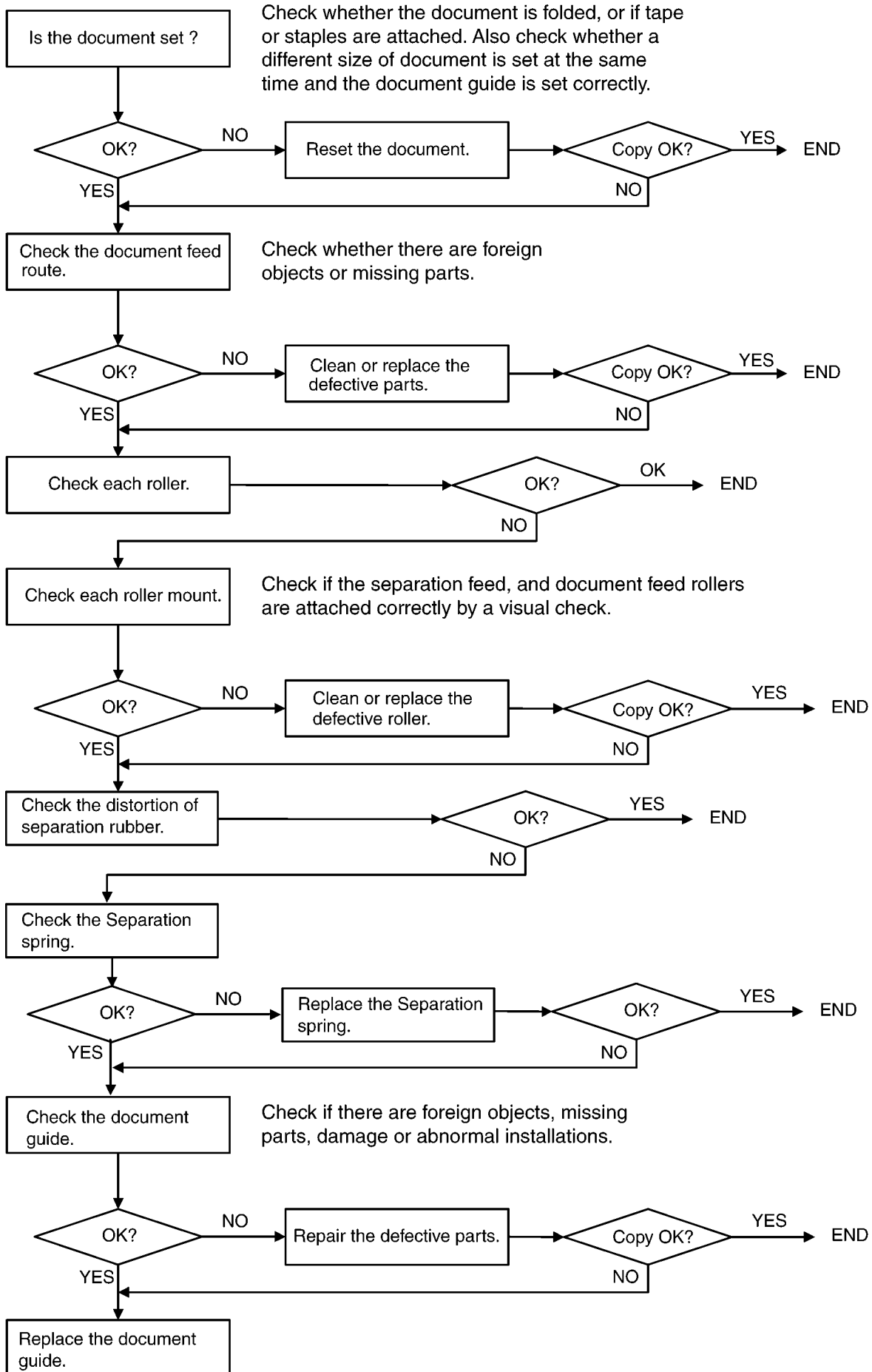

Fig. b

When confirming if the characters are extended or distorted on, if the feed problem occurs, use this test chart. (Fig b)

CROSS REFERENCE:
Motor Section (P.126)

12.2.9.2. Skew (ADF)



12.2.9.3. The Received or Copied Data Is Expanded

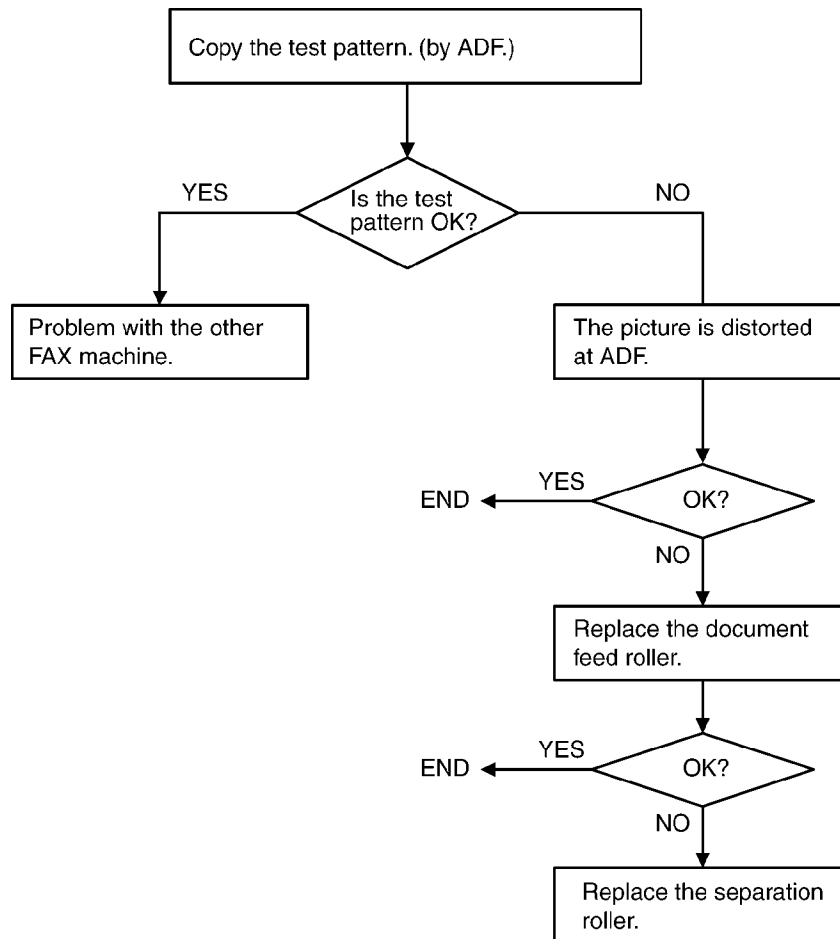

12.2.9.4. Black or White Vertical Line Is Copied

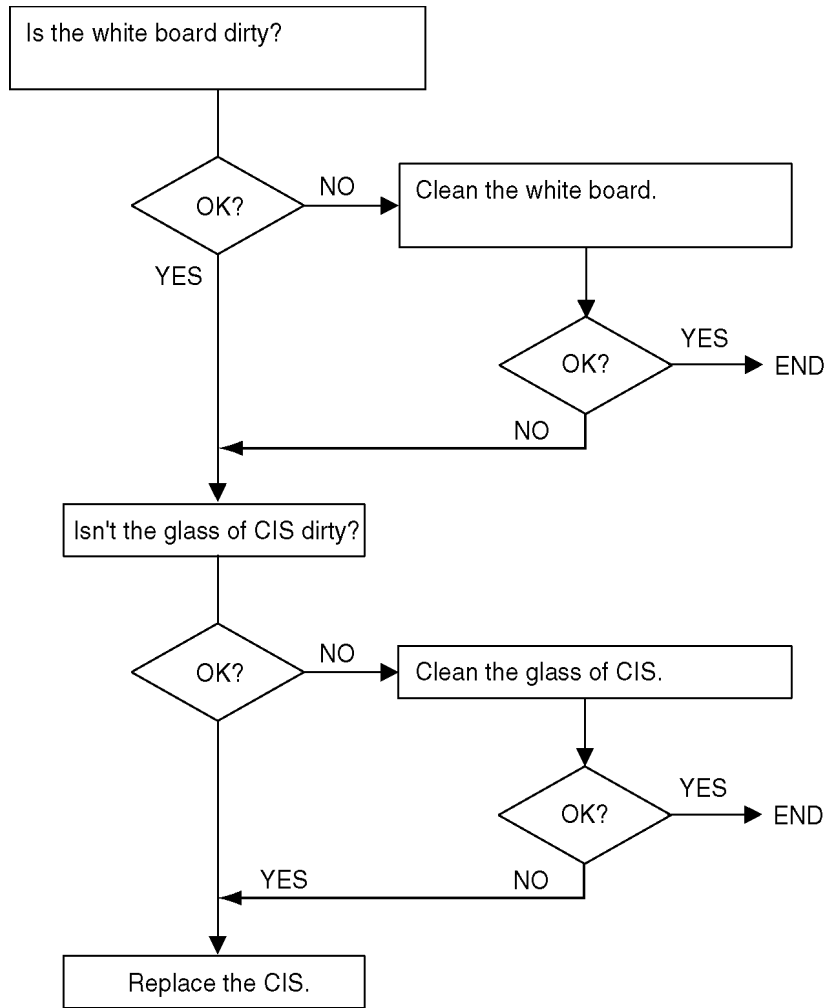

12.2.9.5. An Abnormal Image Is Copied

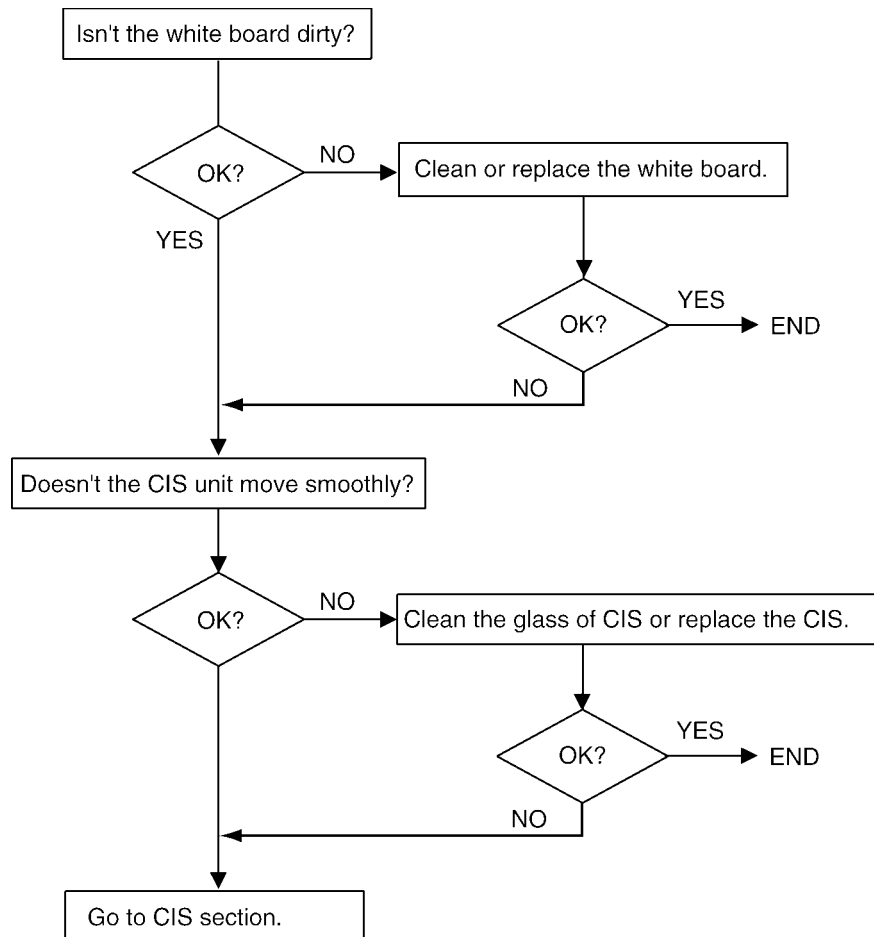

CROSS REFERENCE:
CIS Control Section (P.130)

12.2.10. Initializing Error

After the power is turned on, the SOC (IC300) initializes and checks each IC.

The ROM (IC402) and SDRAM (IC400) are checked.

If initialization fails for the ICs, the system will not boot up.

In this case, please find the cause as follows.

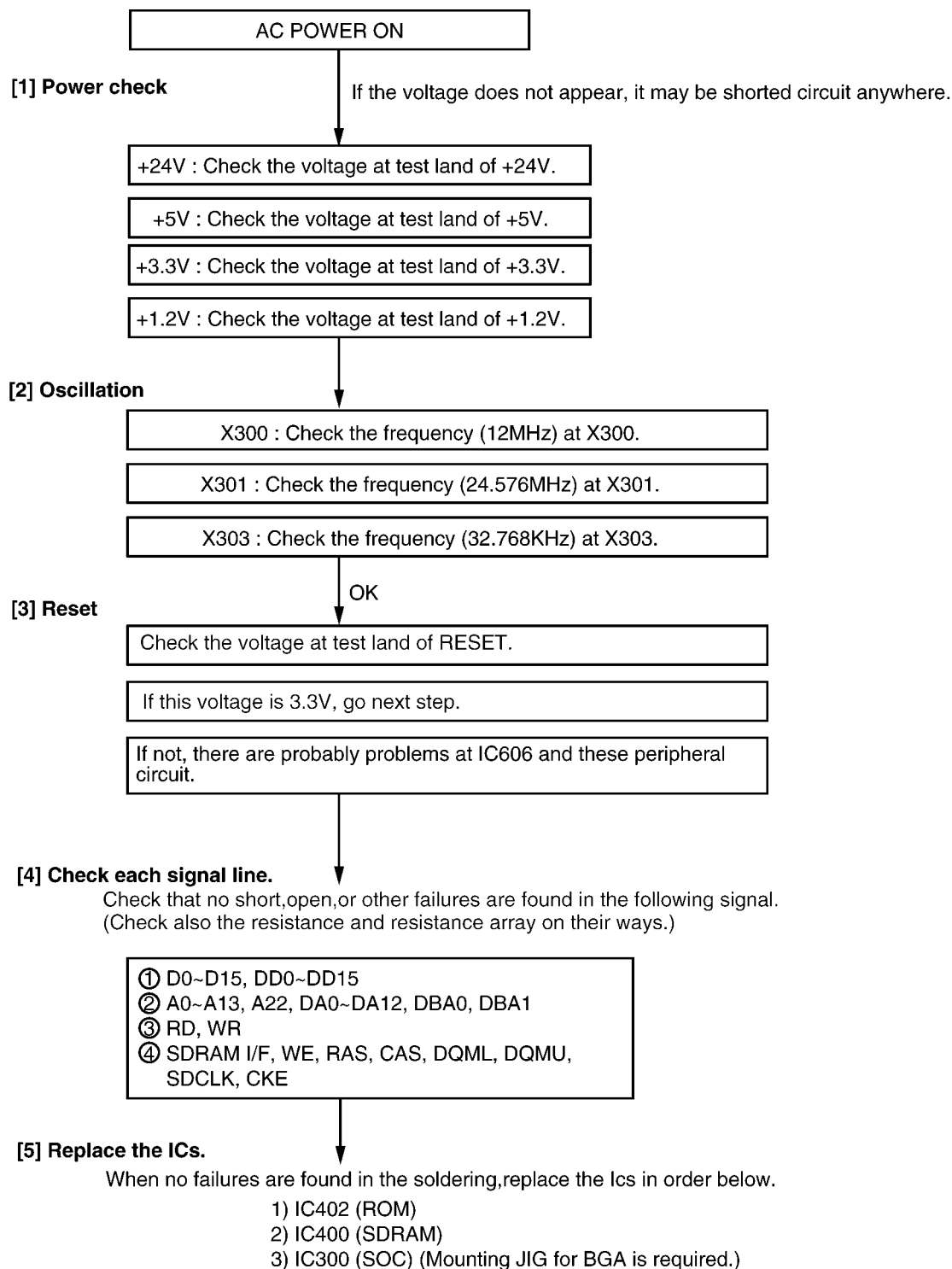

CROSS REFERENCE:

NG Example (P.203)

Power Supply Board Section (P.61)

12.2.11. Operation Panel Section

Refer to **Test Functions** (P.80).

1. NO KEY OPERATION

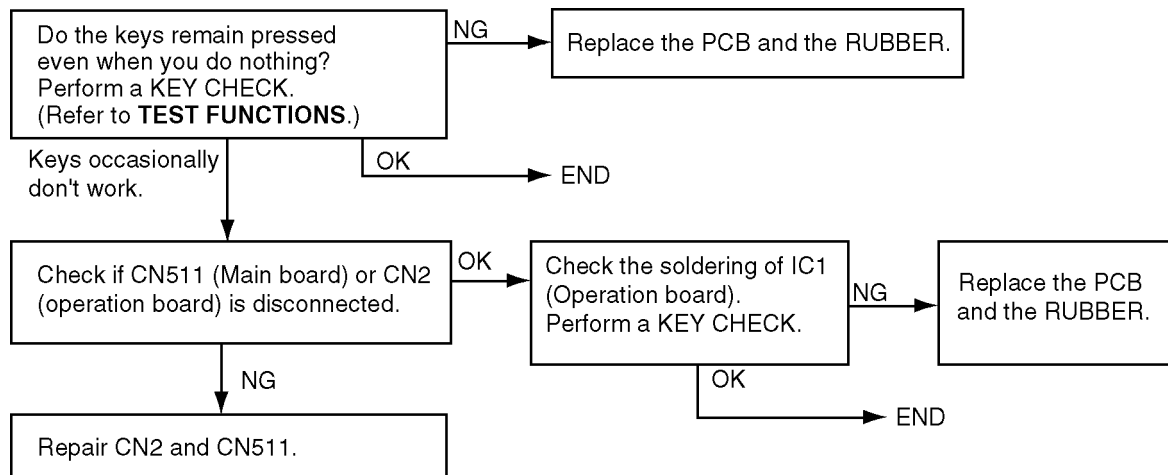

2. NO LCD INDICATION

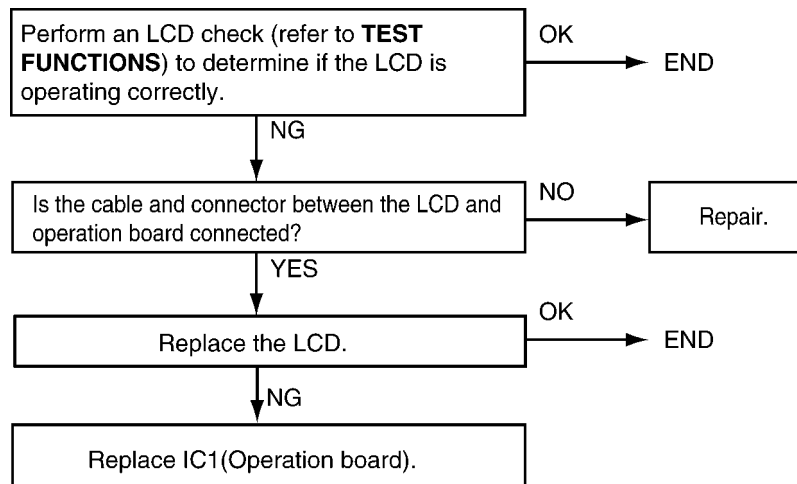

CROSS REFERENCE:
Test Functions (P.80)

12.2.12. Sensor Section

Refer to **SENSORS AND SWITCHES** for the circuit description.

Perform an **SENSOR CHECK** to determine if the sensor is operating correctly.

1. Check the pickup sensor "FAILED PICKUP"

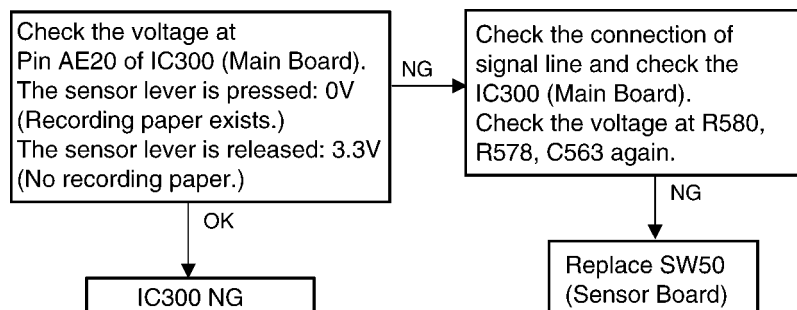

2. Check the paper exit sensor..... “PAPER JAMMED”

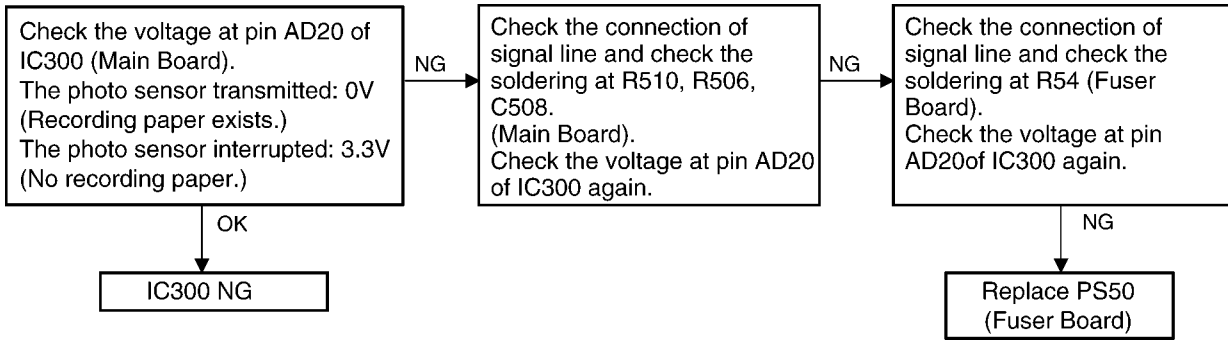

3. Check the home sensor “SCANNER POSITION ERROR”

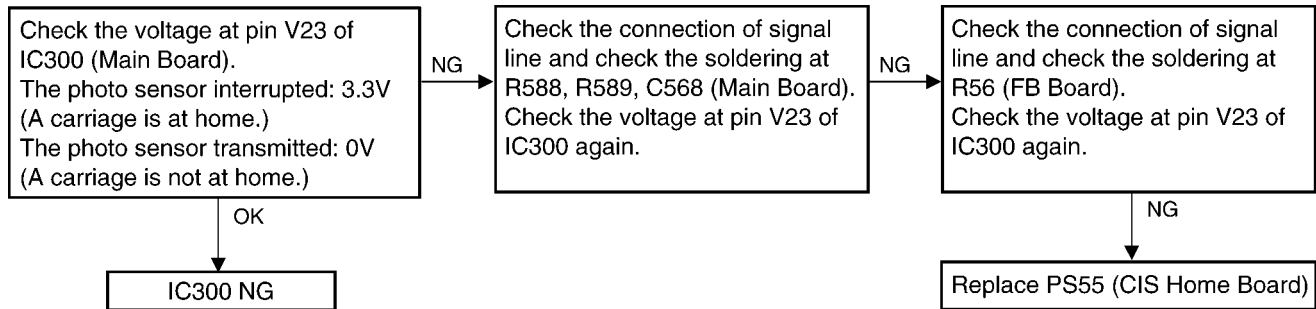

4. Check the read position sensor “CHECK DOCUMENT” (KX-MB2010 ONLY)

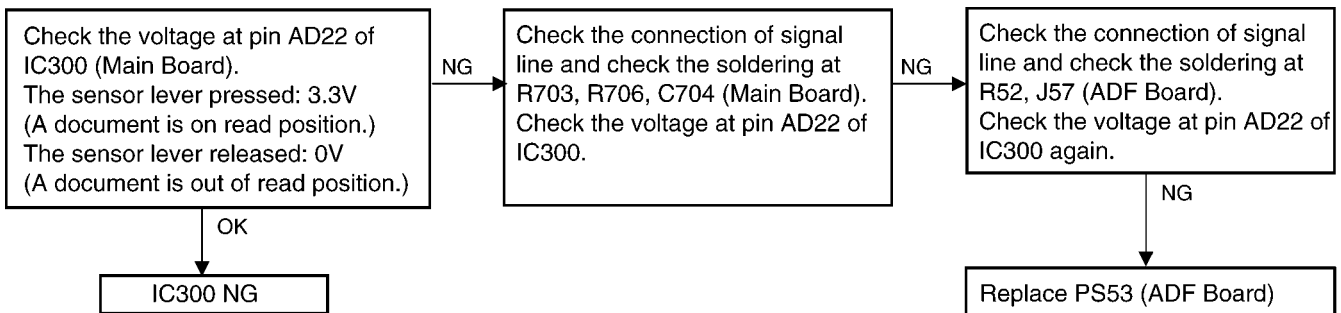

5. Check the registration & manual paper sensor “PAPER JAMMED”

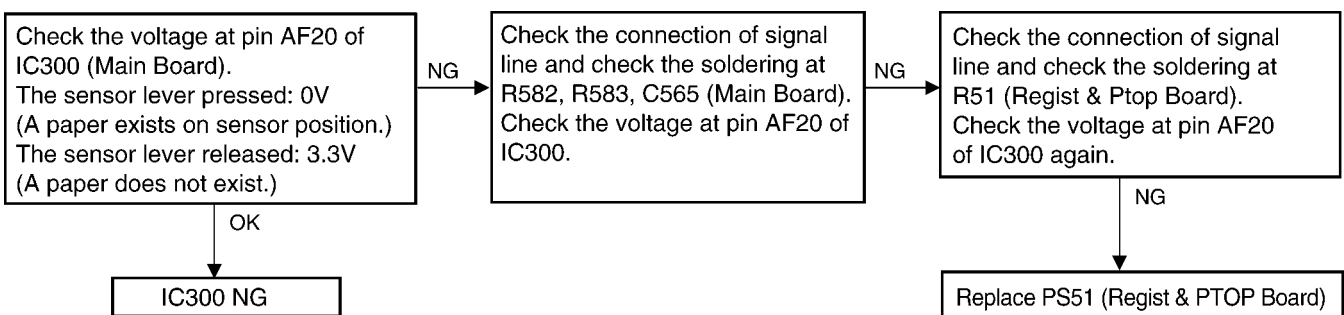

6. Check the print timing sensor “PAPER JAMMED”

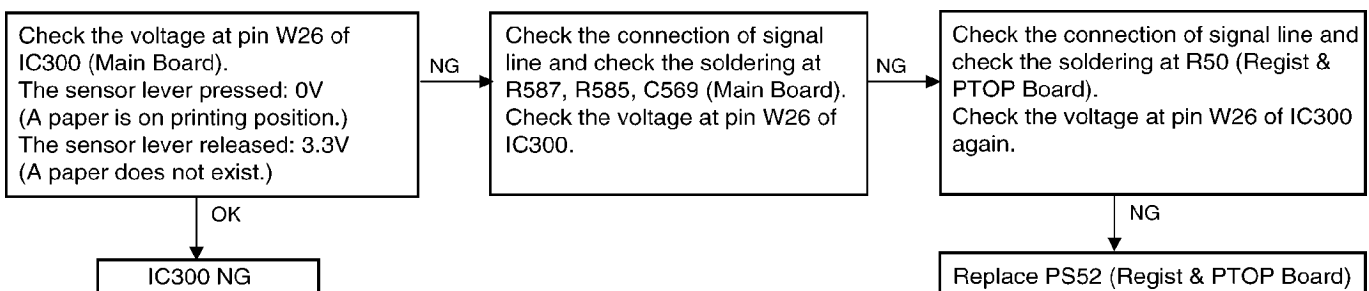

7. Check the document sensor (KX-MB2010 ONLY)

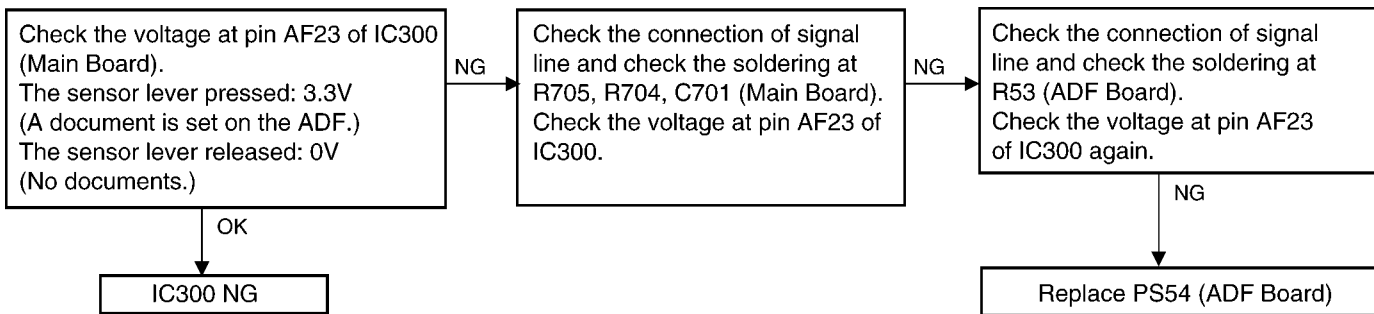

8. Check the top cover sensor “TOP COVER OPEN”

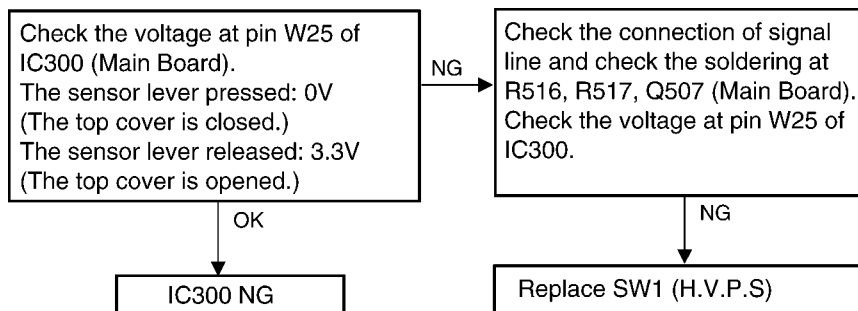

9. Check the toner sensor “TONER LOW”, “CHANGE DRUM”

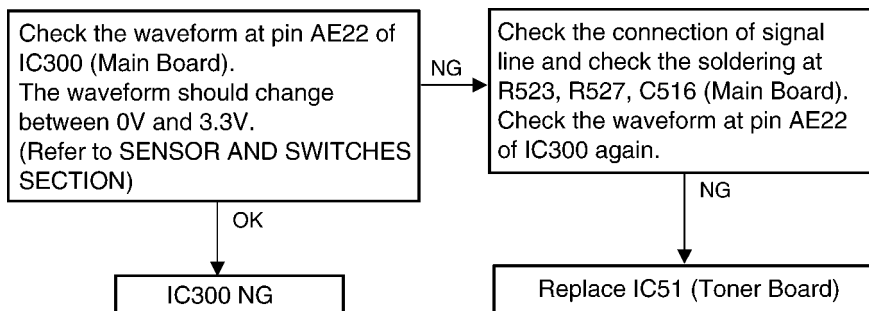

CROSS REFERENCE:
Sensors and Switches Section (P.40)

12.2.13. Motor Section

12.2.13.1. Engine Motor

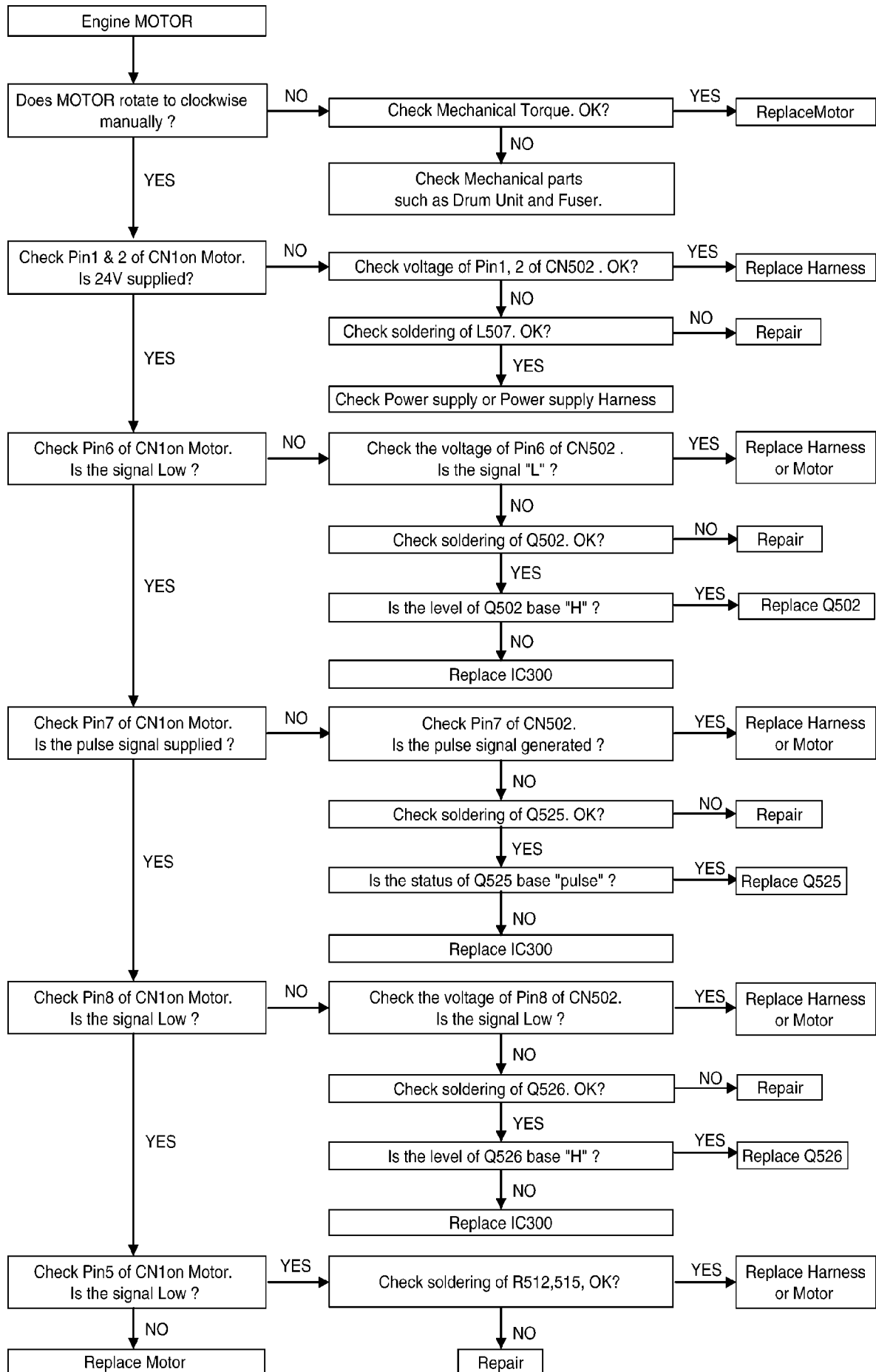

12.2.13.2. FB (Flatbed) Motor

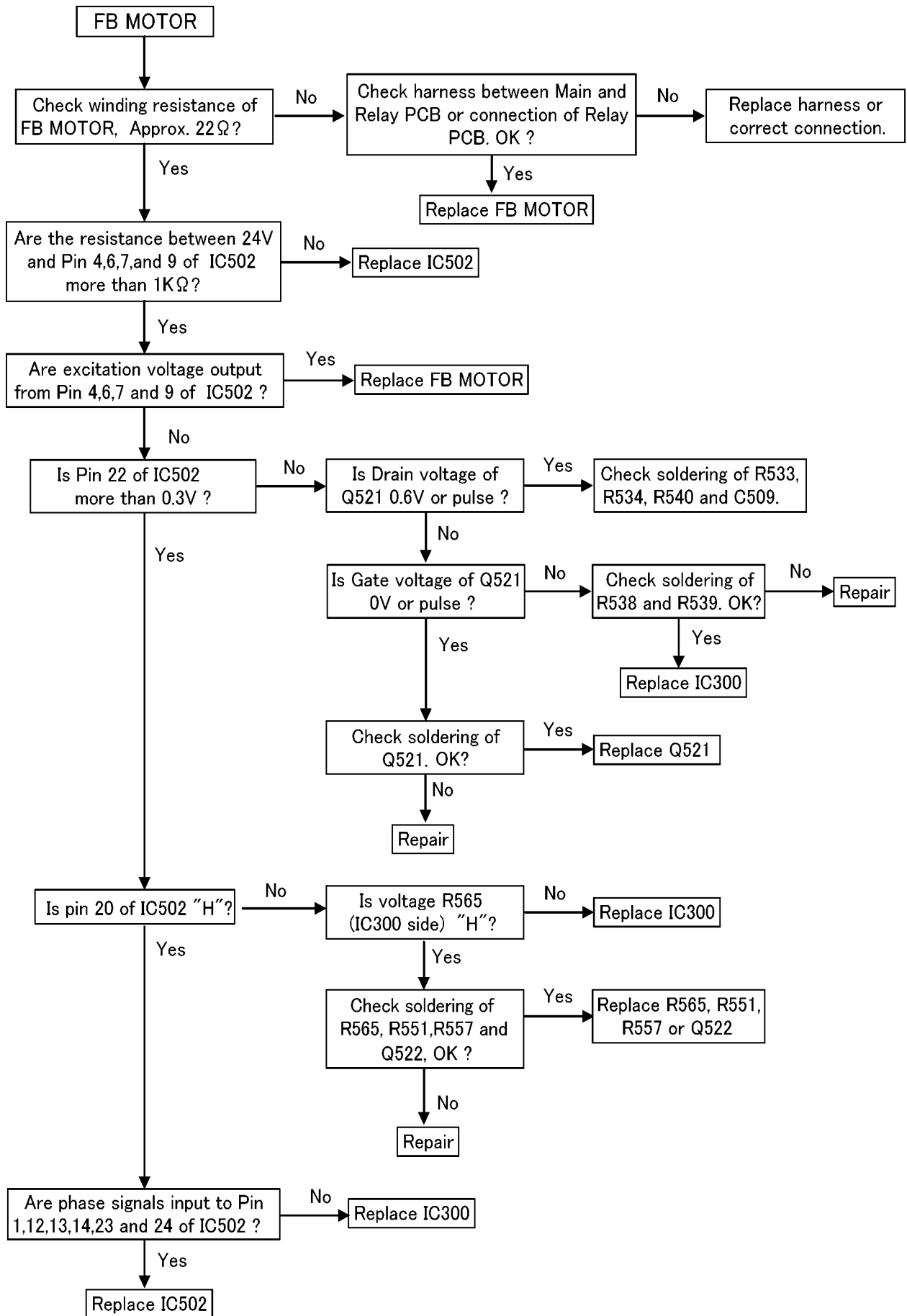

12.2.13.3. ADF Motor (KX-MB2010 ONLY)

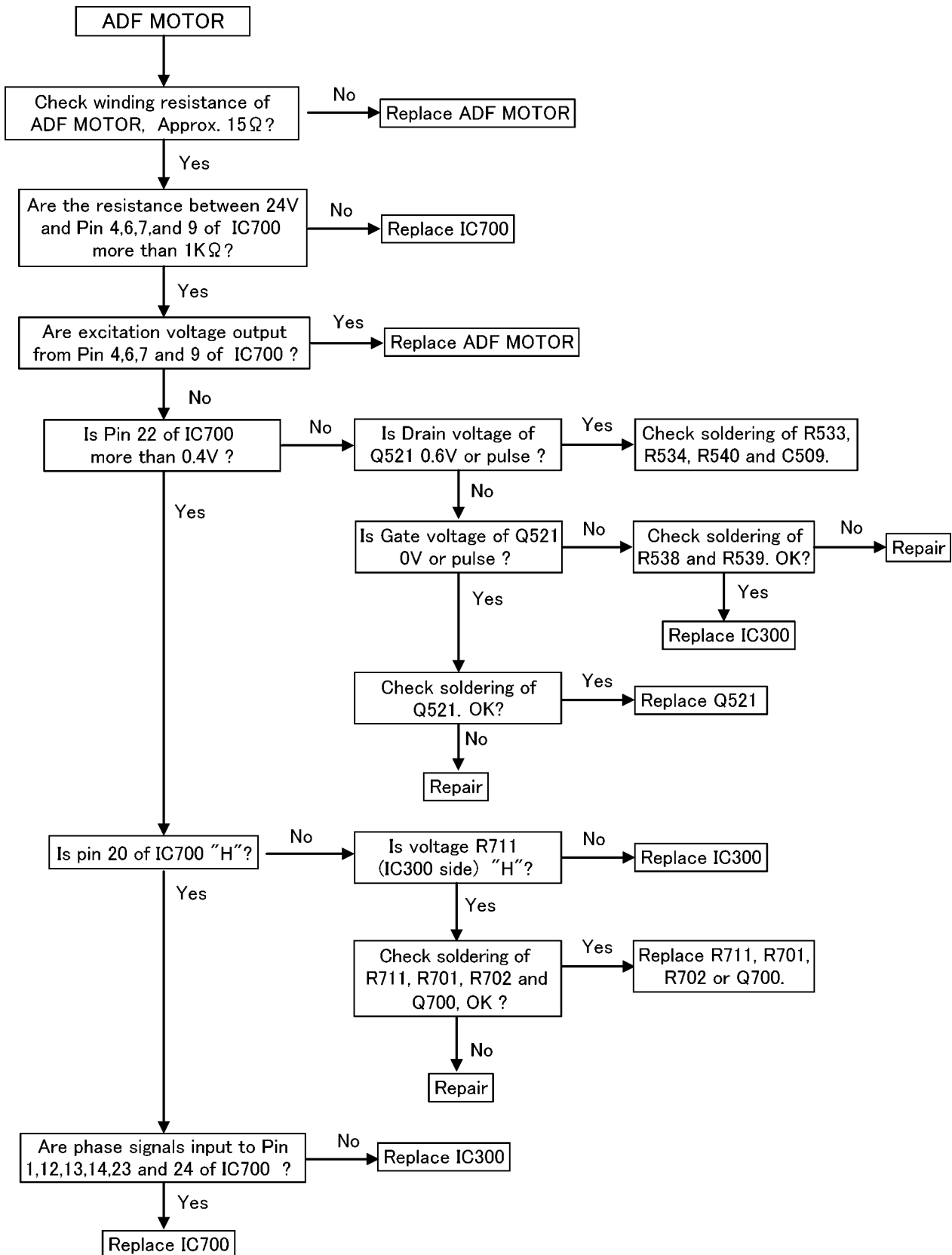

12.2.14. LSU Section

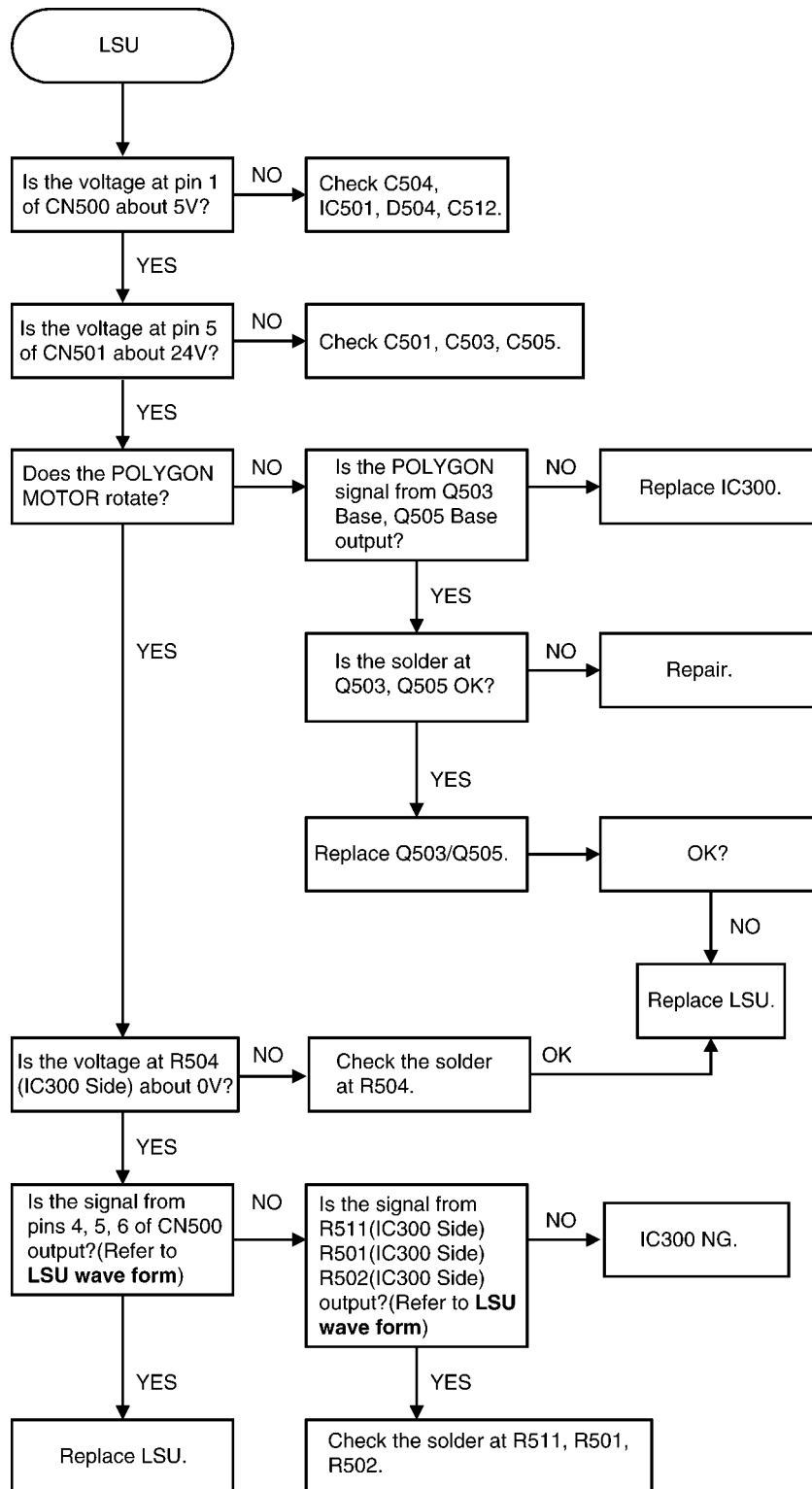

CROSS REFERENCE:
 LSU (Laser Scanning Unit) Section (P.38)

12.2.15. CIS Control Section

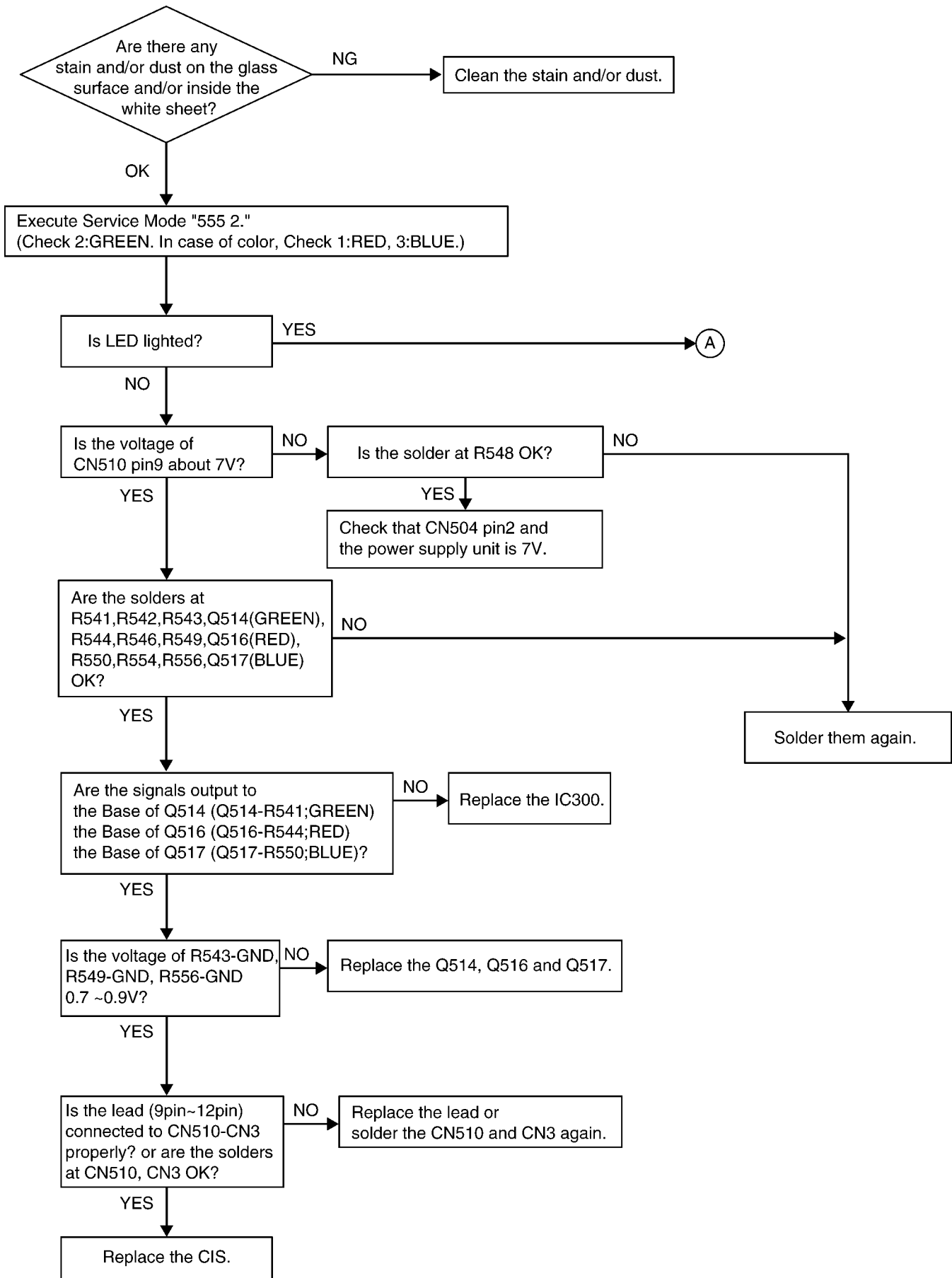

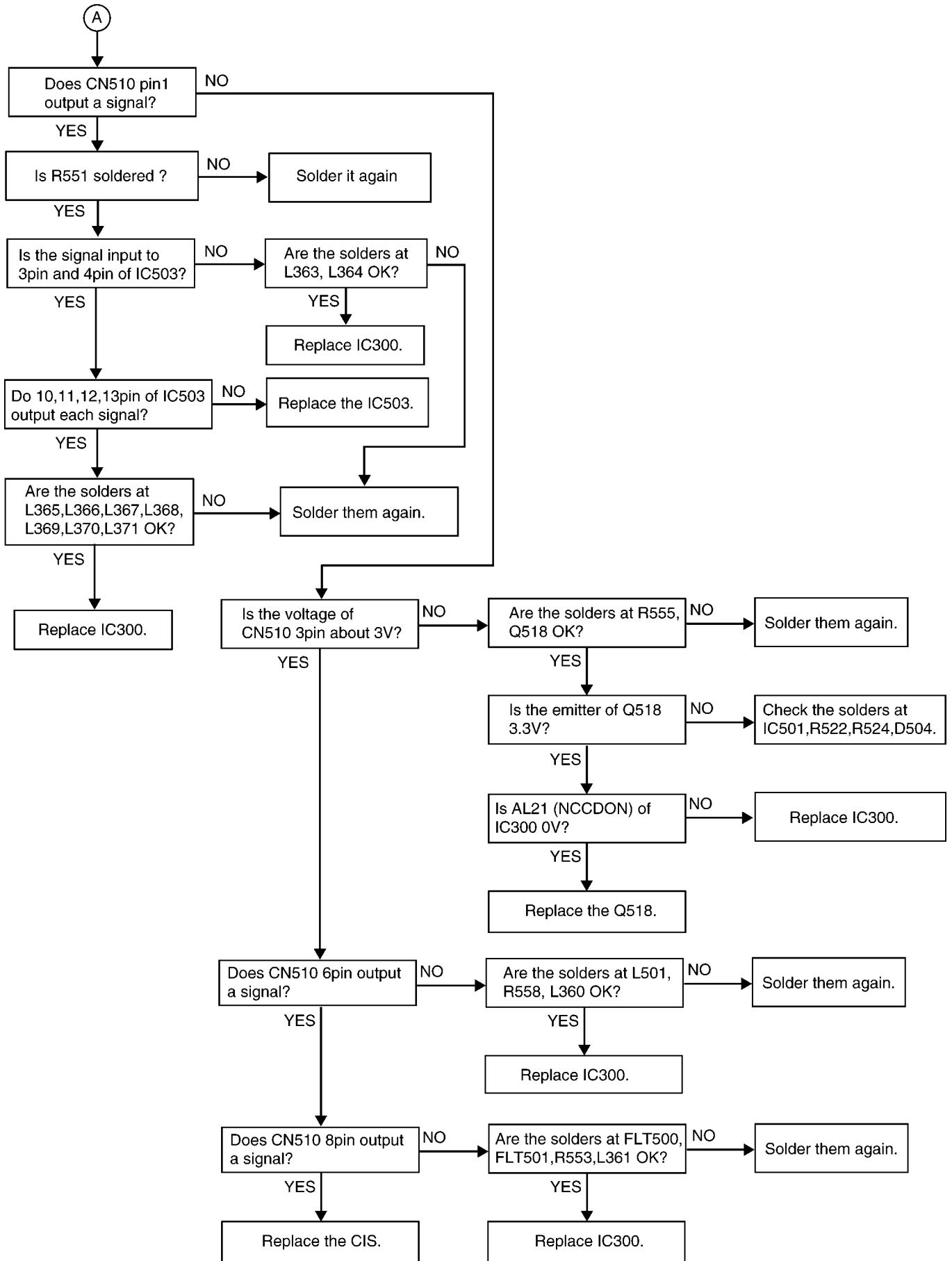

CROSS REFERENCE:
Test Functions (P.80)

12.2.16. High Voltage Value Check Point

Measurement Procedure

1. Turn Off the unit, and open the unit cover.
2. Remove the developing unit, if it is equipped.
3. Connect the wire to the terminal to be measured (Fig. 2). The wire should be put out of the unit not to interfere in other terminals (Fig. 3). See Fig 4 and 5 for fixing the wire to the terminal No.4.
4. Reinstall the developing unit and close the unit cover.
5. Connect the wire fixed to the terminal to be measured and high voltage probe. Connect the earth of the high voltage probe to the screw located under the bottom plate of the unit without the paper cassette. (Fig.7).
6. Turn On the unit. It causes the unit to start the initial operation. Be careful, high voltage is output at that moment. (Avoid measuring then.)
7. The unit enters the service mode. Then push *556_0.
8. Push the SET button.
(High voltage will be added to the unit in the hereafter. Avoid touching the wire and the tip of high voltage probe where high voltage is supplied.)
9. When the measurement is finished, push the STOP button.
(The high voltage output is stopped.)
10. Remove the wire fixed to the output terminal after measuring.

Each terminal's output voltage

No.	BIAS Name	Rated Output	Rated Output Range
1	CHG (Charge)	200 μ A	200 \pm 15 μ A Output voltage about 4.1~4.6KV
2	GRID (Grid)	475V	475 \pm 10V
3	DEV (Developing)	230V	200~300V
4	TRA (Transfer)	785V	785 \pm 100V

* FLUKE85 (MULTIMETER) + HIOKI (HV PROBE 9014) or the equivalent should be used as the high voltage measuring instrument. (Fig.6)

* As for measuring TRA, start measuring within 4 seconds after pressing the SET button. The output value will be changed in 4 seconds.

Fig. 1 Each terminal and the earth point.

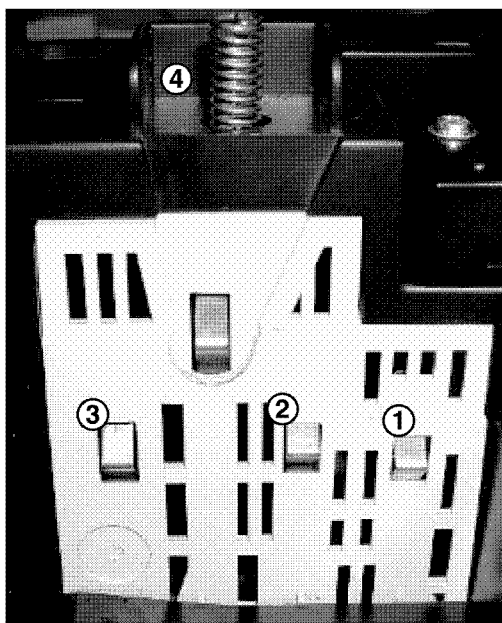

Fig. 2

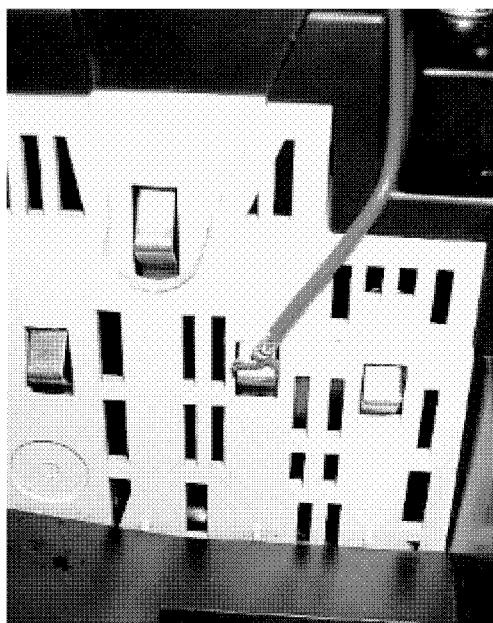

Fig. 3

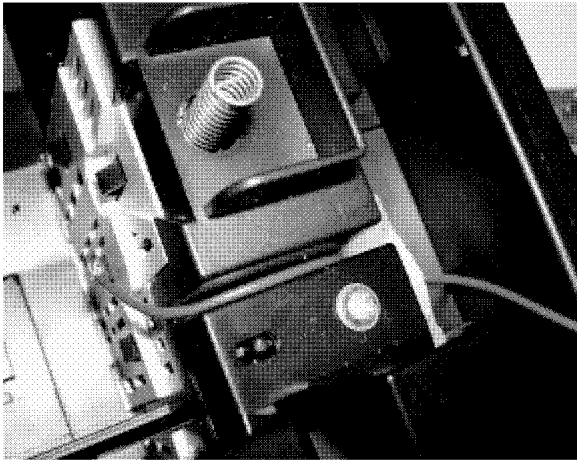

Fig. 4

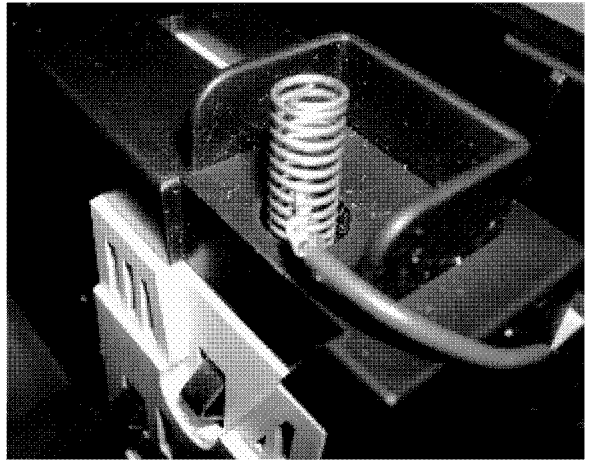

Fig. 5

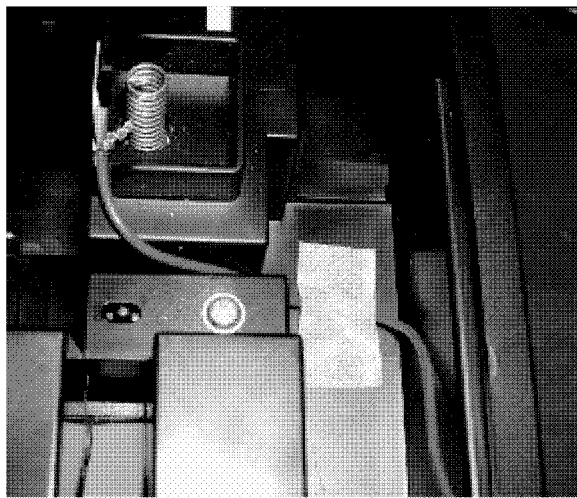

Fig. 6

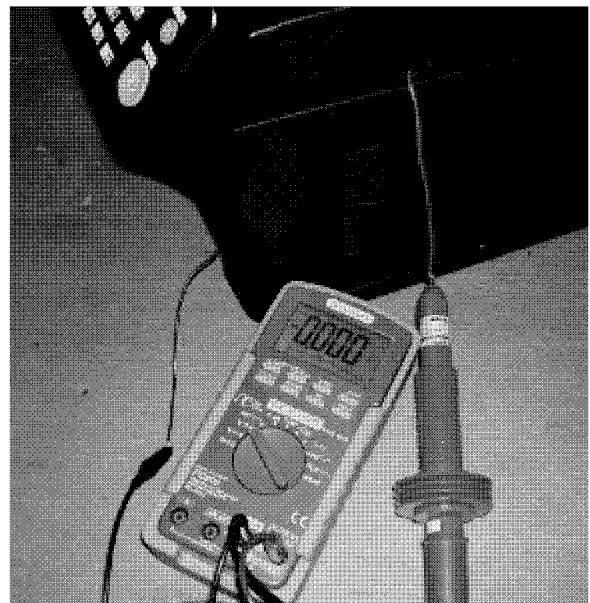
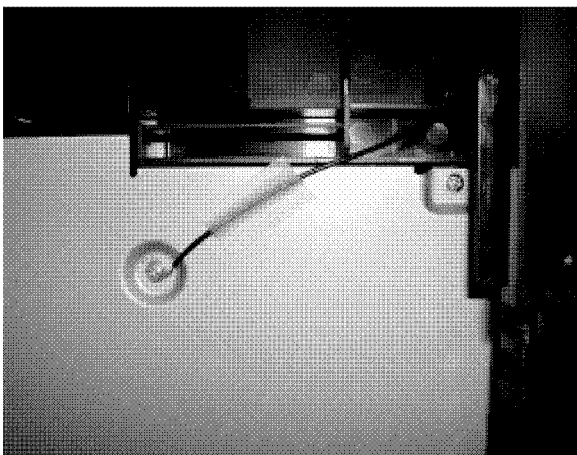
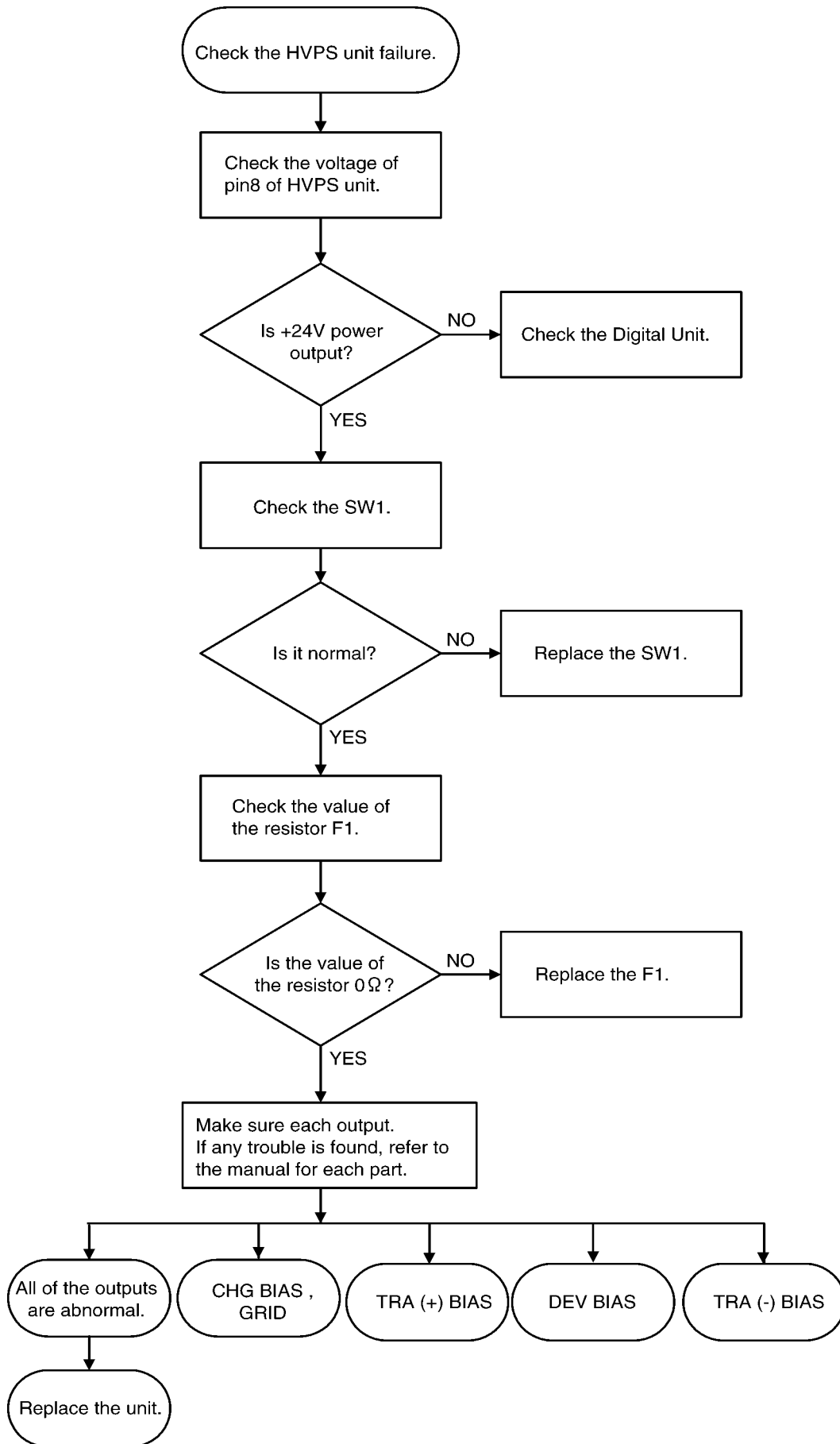

Fig. 7



12.2.17. High Voltage Section

1. Main



2. CHG, GRID

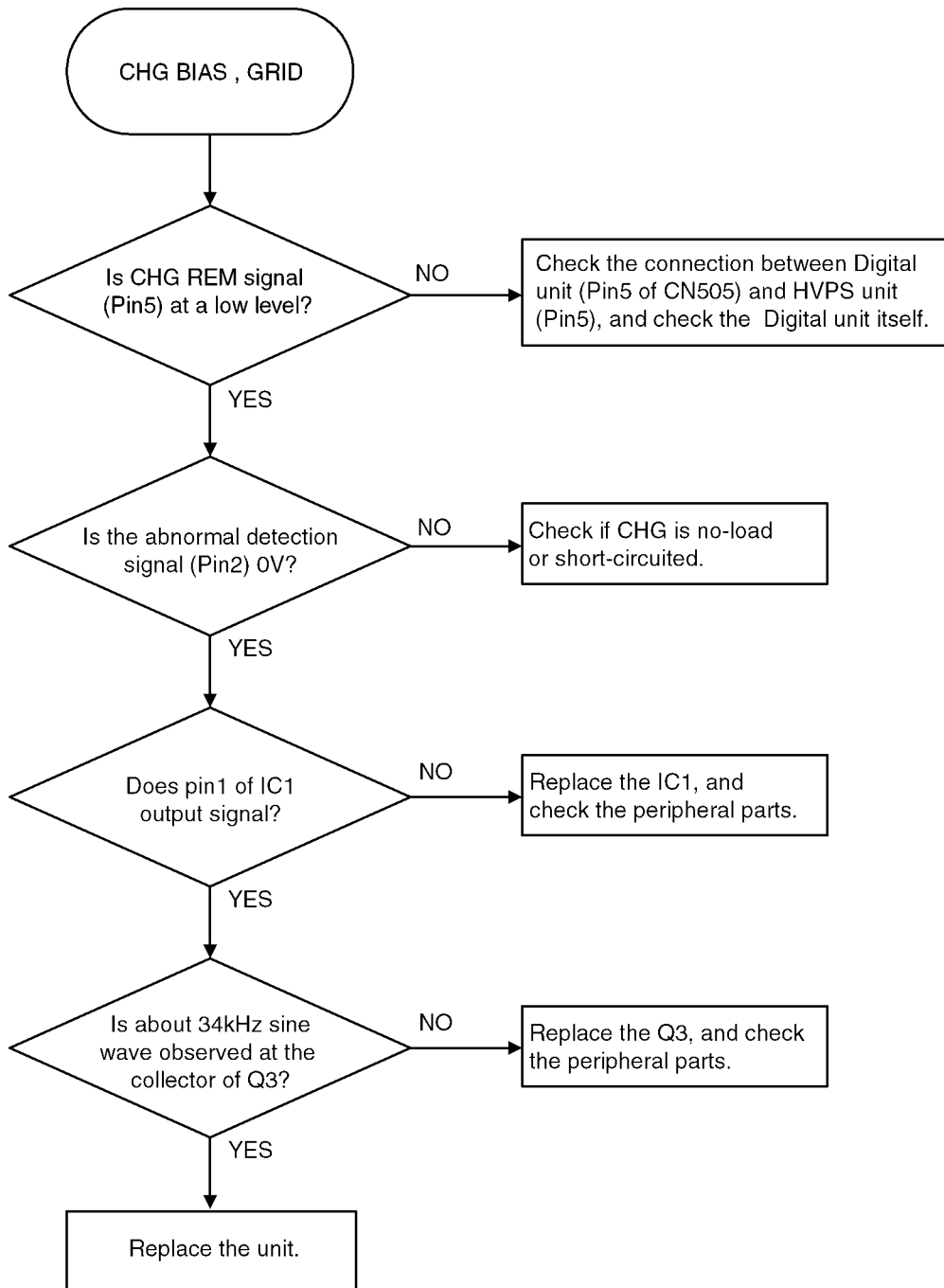

3. TRA (+)

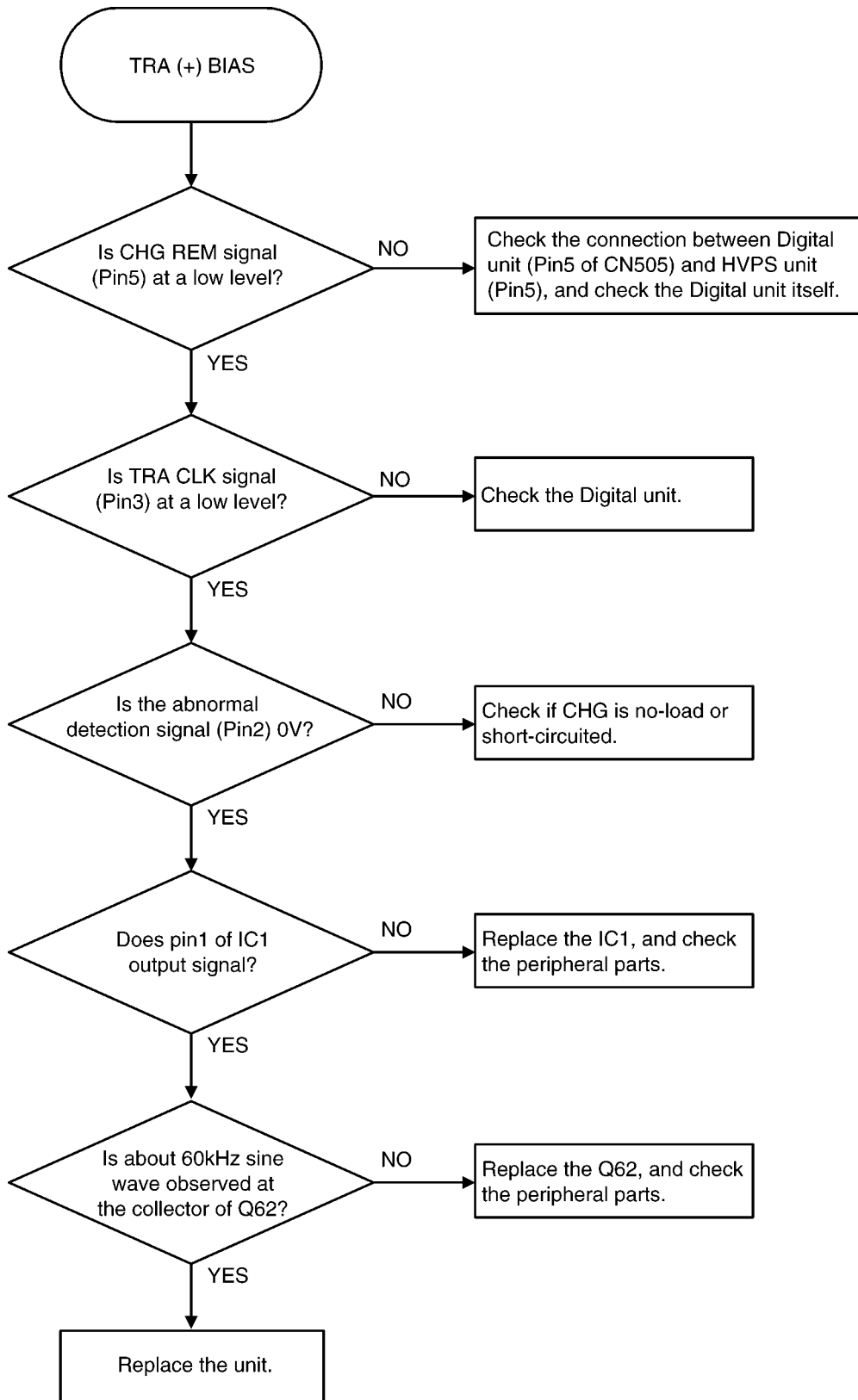

3. DEV DC

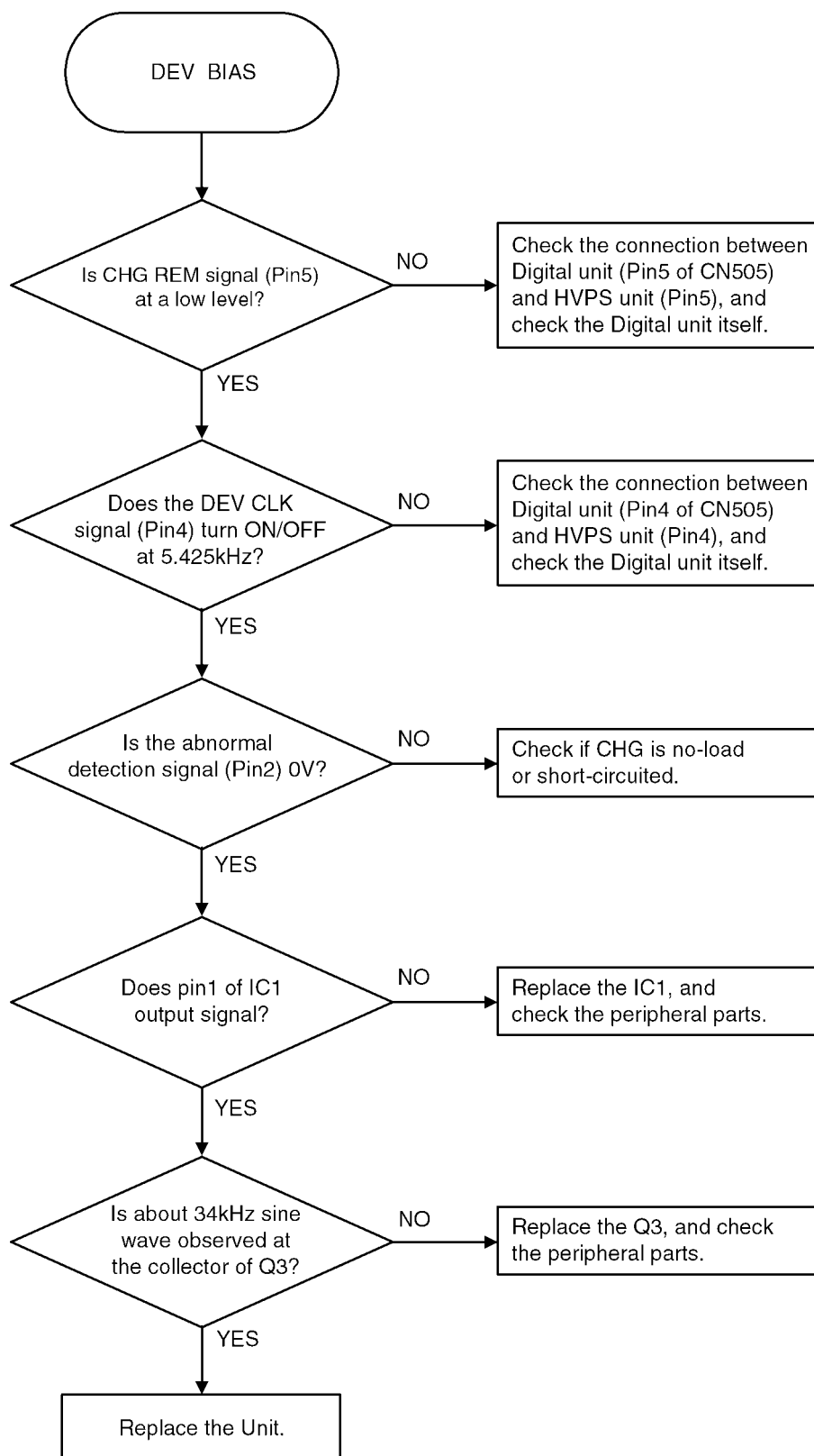

TRA (-)

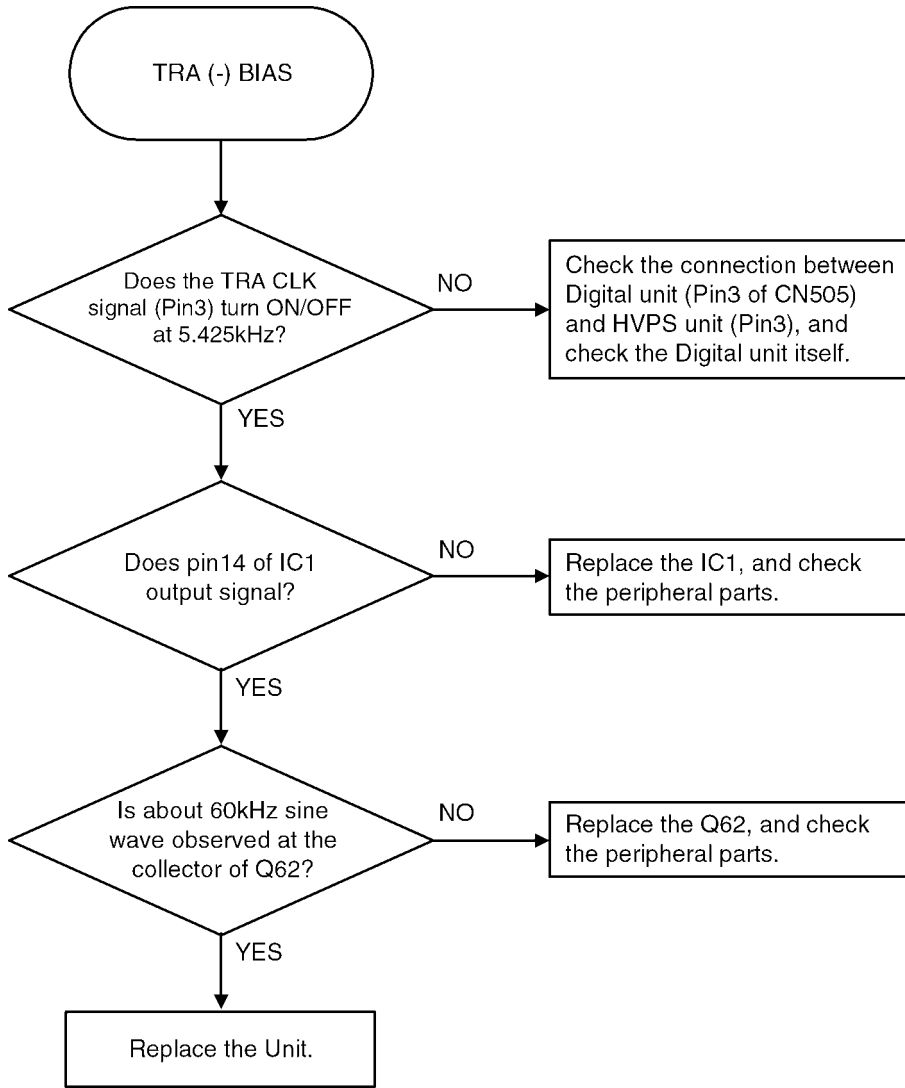

12.2.18. USB Section

Troubleshooting

1. Confirmation of the PC settings

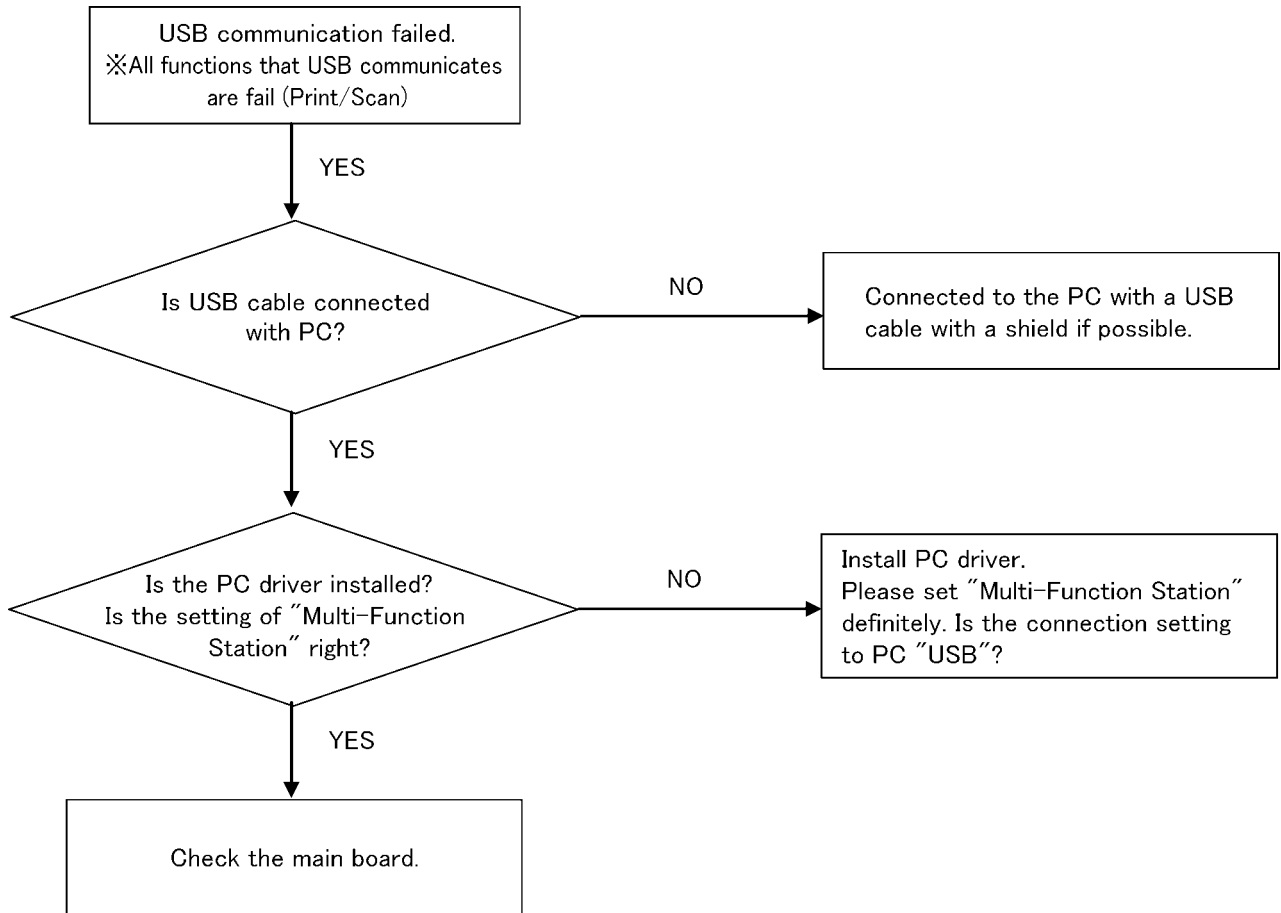

2. Confirmation of the main unit

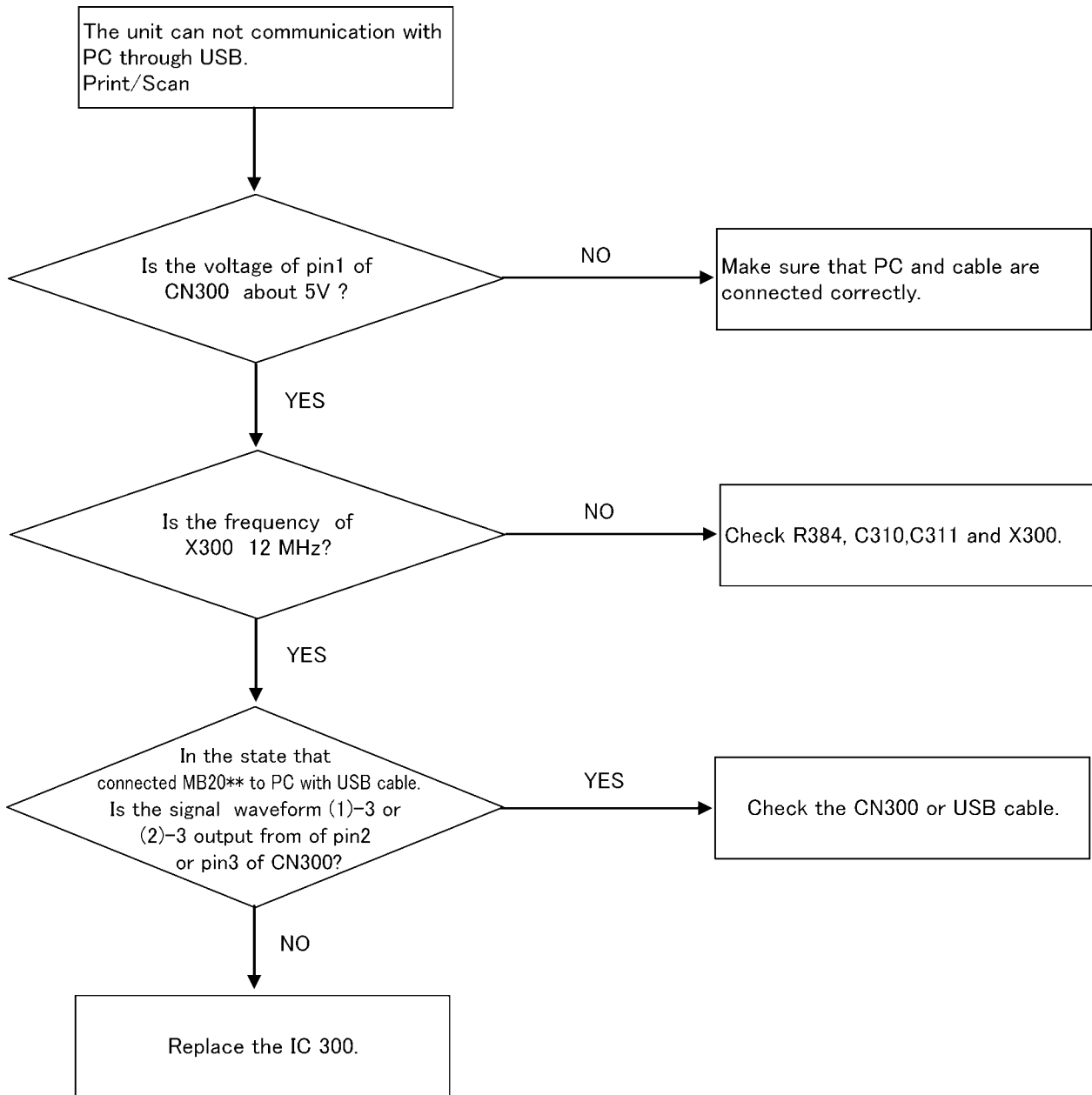

USB (Universal Serial Bus) block

Description

This is a USB block for data communication with PC.

Two signal lines (D+/D-) are differential signals which work in reverse phase.

VBUS: CN300 1pin

D-: CN300 3pin

D+: CN300 2pin

GND: CN300 4pin

Circuit Diagram

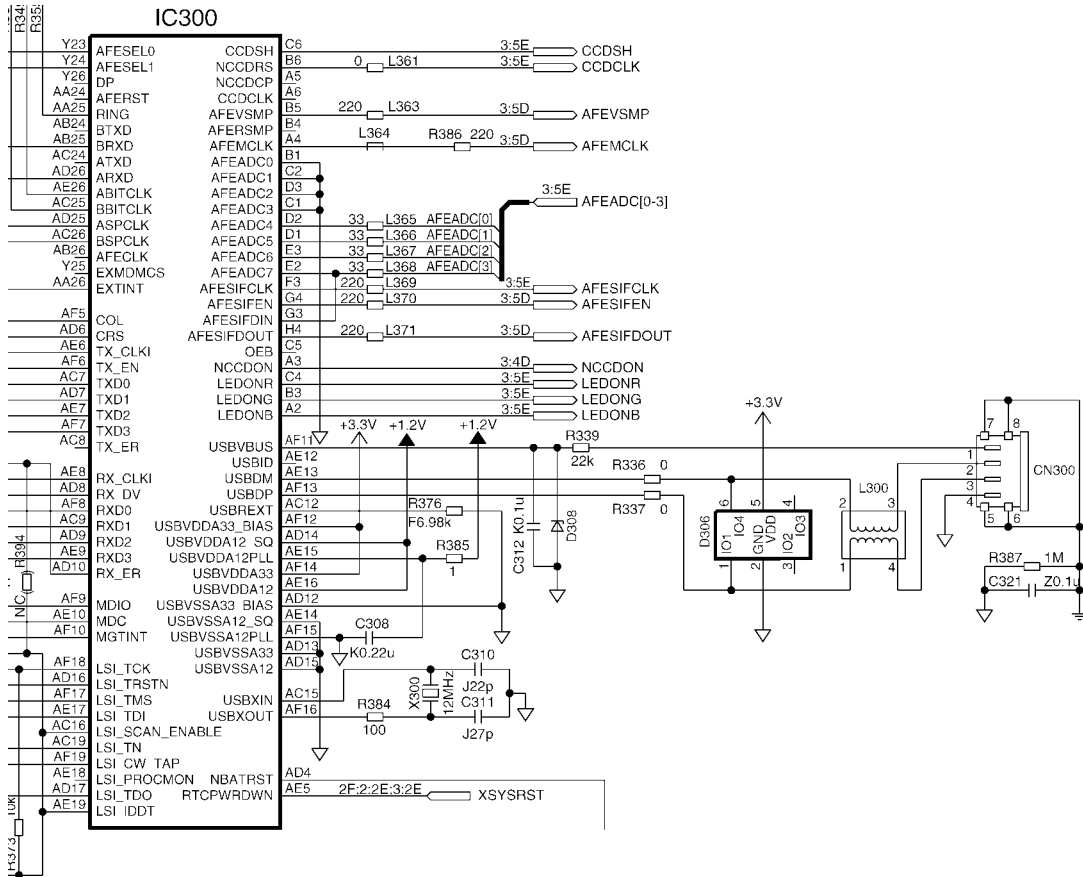

Sequence of normal operation

When USB cable from PC is connected to CN300, VBUS voltage goes up to 5V, and IC300 recognize the connection with PC.

Then D+ becomes about 3V : waveform (1)-1

The D+ becomes 0V, then communication between IC300 and PC is started : waveform (2)-1

When a few seconds elapsed after USB cable was inserted into CN300 ,the unit enters stand-by mode.

When PC is at Hi-Speed , waveforms are (1)-1 ~ (1)-4.

When PC is at Full Speed ,waveforms are (2)-1 ~ (2)-4.

Waveform of normal operation

(1) The condition during communication establishment between PC and Main unit at Hi-Speed.

Waveform (1)-1 at Hi-Speed

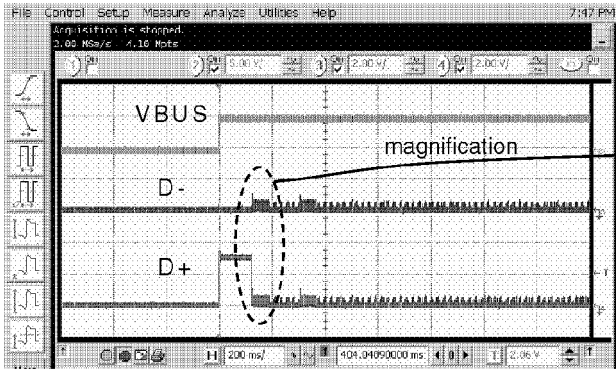

Waveform (1)-2 at Hi-Speed

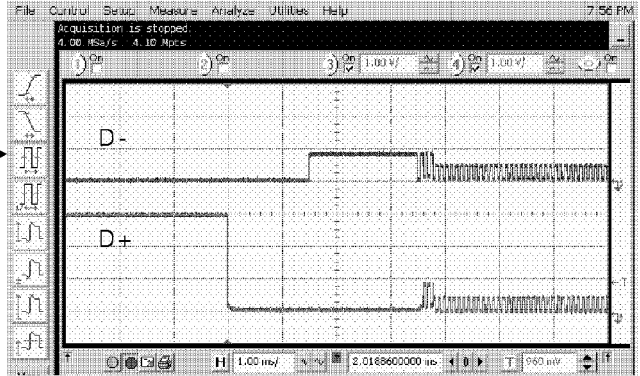

Waveform (1)-3 at Hi-Speed

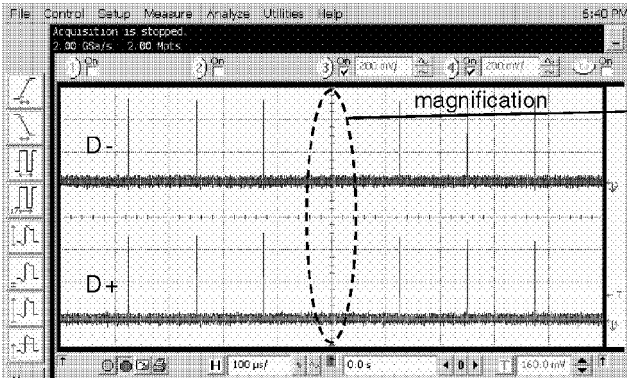

Waveform (1)-4 at Hi-Speed

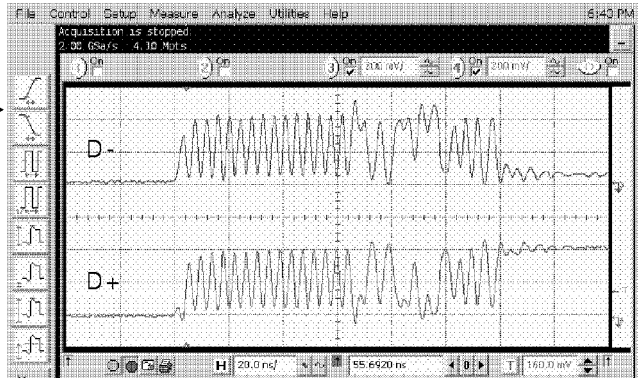

(2) The condition during communication establishment between PC and Main unit at Full Speed.

Waveform (2)- 1 at Full Speed

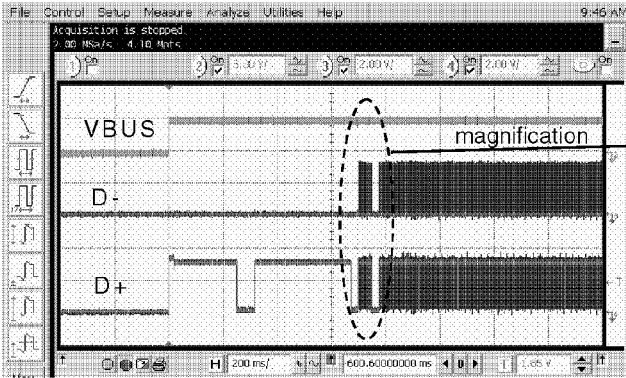

Waveform (2)-2 at Full Speed

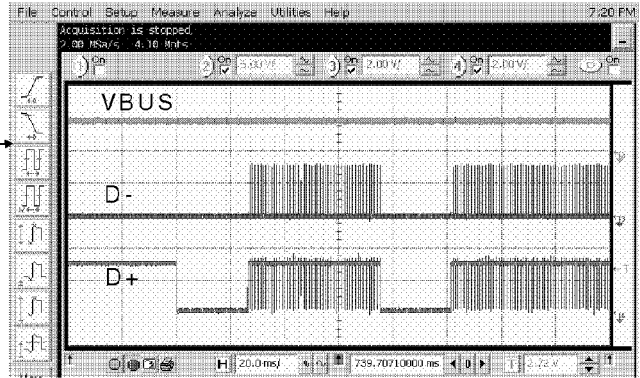

Waveform (2)-3 at Full Speed

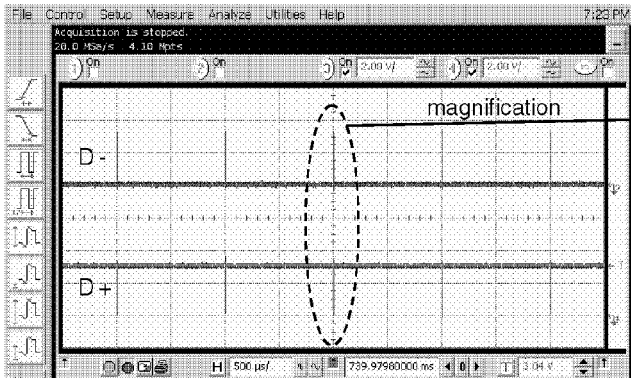

Waveform (2)-4 at Full Speed

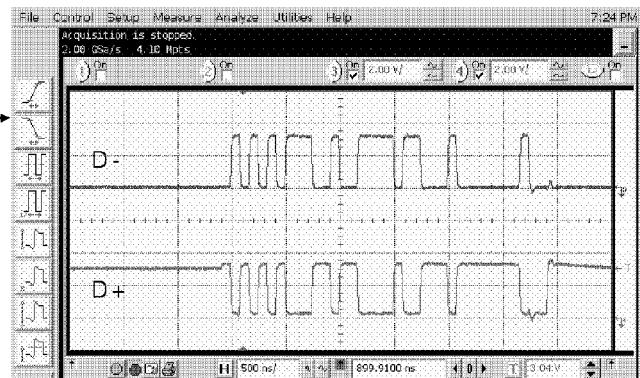

12.2.19. LAN SECTION

LAN Block Diagram

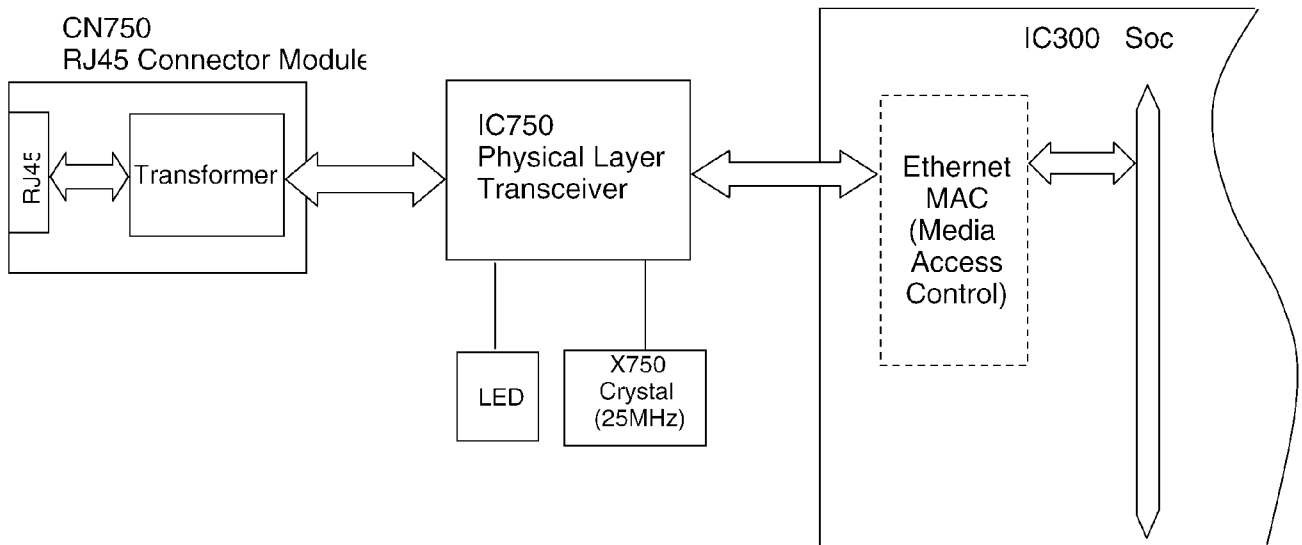
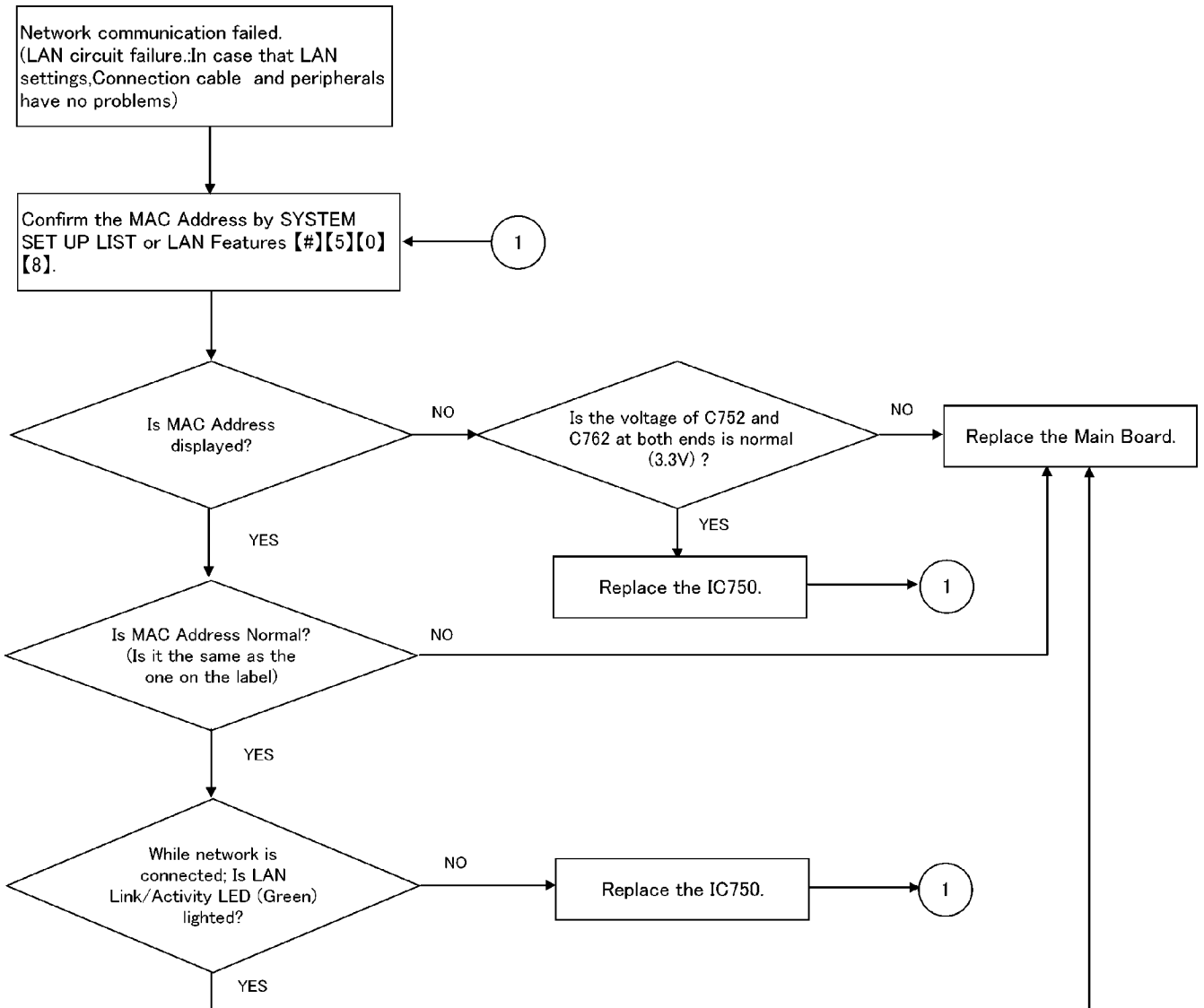

LAN Circuit signal waveform (Normal)

Transmitter waveform [TD+ (CN750 pin1), TD- (CN750 pin2) differential voltage] : Differential probe is used.

1. When network equipment is not connected (LAN cable is not connected);

① Auto negotiation waveform 1

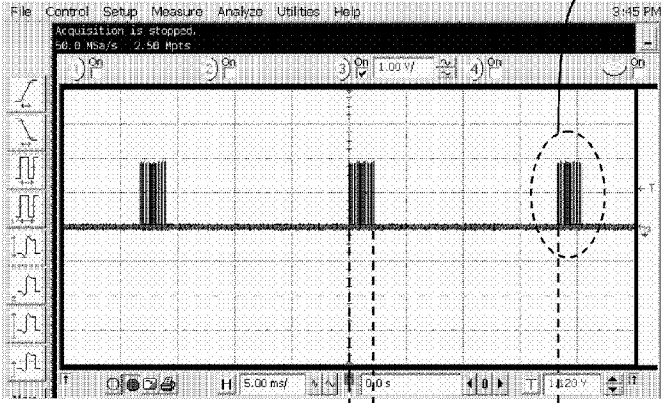

about 2msec
about 16 ± 8 msec

② Auto negotiation waveform 2 (A part of the waveform1 is magnified.)

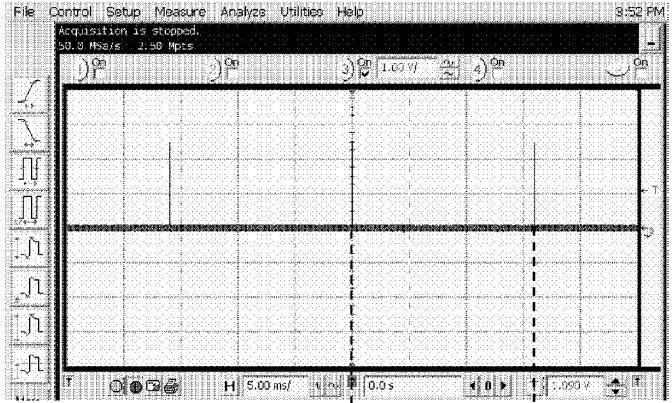

about 62.5μ sec

2. When 100Base-TX-enabled device is connected;

① 100Base-TX waveform 1

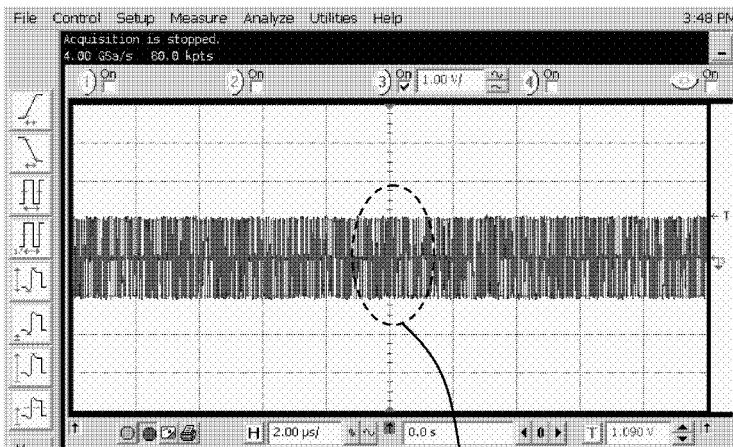

② 100Base-TX waveform 2 (A part of the waveform1 is magnified.)

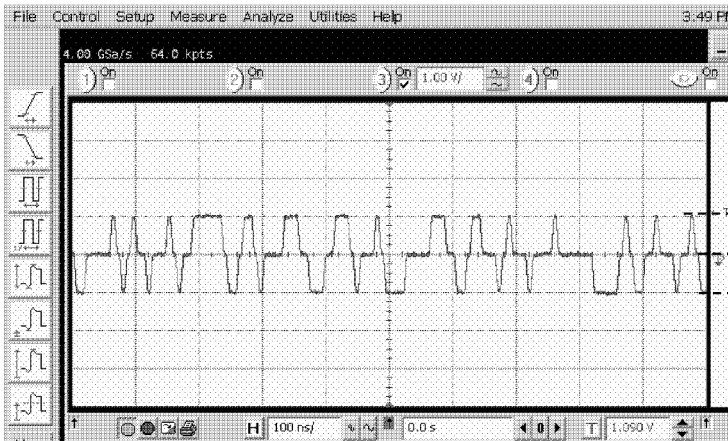

+Vout : about +1V
-Vout : about -1V

3. When 10Base-T-enabled device is connected.

① 10Base-T waveform 1 [Link Pulse]

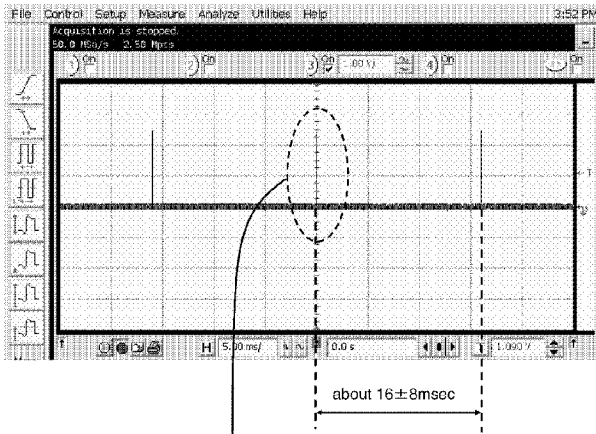

② 10Base-T waveform 2 [Link Pulse]
(A part of the waveform 1 is magnified.)

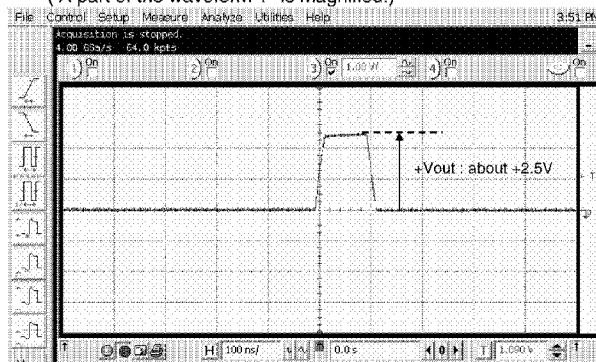

③ 10Base-T waveform 3 [during data commnication]

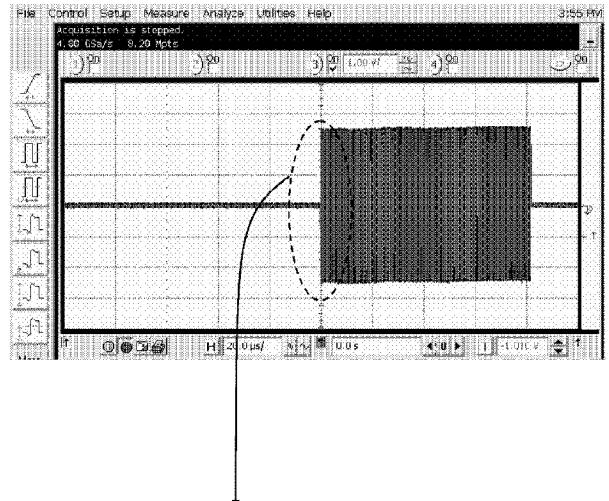

④ 10Base-T waveform 4 [during data commnication]
(A part of the waveform 3 is magnified.)

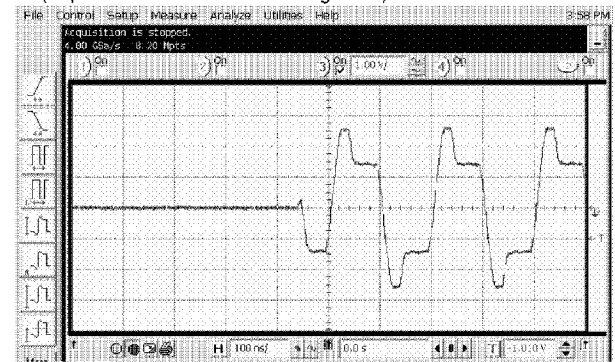

IC750 (C1CB00002566 : 3.3V Single Power Supply) Pin Description

Pin No	Signal Name	Input/Output(*)	Description
1	GND	Gnd	Ground
2	VDDPLL_1.8	P	1.8V analog VDD
3	VDDA_3.3	P	3.3V analog VDD
4	RX-	I/O	Physical receive or transmit signal (- differential)
5	RX+	I/O	Physical receive or transmit signal (+ differential)
6	TX-	I/O	Physical transmit or receive signal (- differential)
7	TX+	I/O	Physical transmit or receive signal (+ differential)
8	XO	O	Crystal feedback This pin is used only in MII mode when a 25 MHz crystal is used. This pin is a no connect if oscillator or external clock source is used, or if RMII mode is selected.
9	XI / REFCLK	I	Crystal / Oscillator / External Clock Input MII Mode: 25MHz +/-50ppm (crystal, oscillator, or external clock) RMII Mode: 50MHz +/-50ppm (oscillator, or external clock only)
10	REXT	I/O	Set physical transmit output current Connect a 6.49K Ω resistor in parallel with a 100pF capacitor to ground on this pin. See KSZ8041NL reference schematics.
11	MDIO	I/O	Management Interface (MII) Data I/O This pin requires an external 4.7K Ω pull-up resistor.
12	MDC	I	Management Interface (MII) Clock Input This pin is synchronous to the MDIO data interface.
13	RXD3 / PHYAD0	Ipu/O	MII Mode: Receive Data Output[3](2) / Config Mode: The pull-up/pull-down value is latched as PHYADDR[0] during power-up / reset. See "Strapping Options" section for details.
14	RXD2 / PHYAD1	Ipd/O	MII Mode: Receive Data Output2 / Config Mode: The pull-up/pull-down value is latched as PHYADDR[1] during power-up / reset. See "Strapping Options" section for details.
15	RXD1 / RXD[1] / PHYAD2	Ipd/O	MII Mode: Receive Data Output[1](2) / RMII Mode: Receive Data Output[1](3) / Config Mode: The pull-up/pull-down value is latched as PHYADDR[2] during power-up / reset. See "Strapping Options" section for details.
16	RXD0 / RXD[0] / DUPLEX	Ipu/O	MII Mode: Receive Data Output[0](2) / RMII Mode: Receive Data Output[0](3) / Config Mode: Latched as DUPLEX (register 0h, bit 8) during power-up / reset. See "Strapping Options" section for details.
17	VDDIO_3.3	P	3.3V digital VDD
18	RXDV / CRSDV / CONFIG2	Ipd/O	MII Mode: Receive Data Valid Output / RMII Mode: Carrier Sense/Receive Data Valid Output / Config Mode: The pull-up/pull-down value is latched as CONFIG2 during power-up / reset. See "Strapping Options" section for details.
19	RXC	O	MII Mode: Receive Clock Output
20	RXER / RX_ER / ISO	Ipd/O	MII Mode: Receive Error Output / RMII Mode: Receive Error Output / Config Mode: The pull-up/pull-down value is latched as ISOLATE during power-up / reset. See "Strapping Options" section for details.
21	INTRP	Opu	Interrupt Output: Programmable Interrupt Output Register 1Bh is the Interrupt Control/Status Register for programming the interrupt conditions and reading the interrupt status. Register 1Fh bit 9 sets the interrupt output to active low (default) or active high.
22	TXC	O	MII Mode: Transmit Clock Output
23	TXEN / TX_EN	I	MII Mode: Transmit Enable Input / RMII Mode: Transmit Enable Input
24	TXD0 / TXD[0]	I	MII Mode: Transmit Data Input[0](4) / RMII Mode: Transmit Data Input[0](5)
25	TXD1 / TXD[1]	I	MII Mode: Transmit Data Input[1](4) / RMII Mode: Transmit Data Input[1](5)
26	TXD2	I	MII Mode: Transmit Data Input[2](4) /
27	TXD3	I	MII Mode: Transmit Data Input[3](4) /
28	COL / CONFIG0	Ipd/O	MII Mode: Collision Detect Output / Config Mode: The pull-up/pull-down value is latched as CONFIG0 during power-up / reset. See "Strapping Options" section for details.
29	CRS / CONFIG1	Ipd/O	MII Mode: Carrier Sense Output / Config Mode: The pull-up/pull-down value is latched as CONFIG1 during power-up / reset. See "Strapping Options" section for details.

Pin No	Signal Name	Input/Output(*)	Description																											
30	LED0 / NWAYEN	Ipu/O	<p>LED Output: Programmable LED0 Output / Config Mode: Latched as Auto-Negotiation Enable (register 0h, bit 12) during power-up / reset. See “Strapping Options” section for details. The LED0 pin is programmable via register 1Eh bits [15:14], and is defined as follows.</p> <table border="1"> <thead> <tr> <th colspan="3">LED mode = [00]</th> </tr> <tr> <th>Link/Activity</th> <th>Pin State</th> <th>LED Definition</th> </tr> </thead> <tbody> <tr> <td>No Link</td> <td>H</td> <td>OFF</td> </tr> <tr> <td>Link</td> <td>L</td> <td>ON</td> </tr> <tr> <td>Activity</td> <td>Toggle</td> <td>Blinking</td> </tr> </tbody> </table> <table border="1"> <thead> <tr> <th colspan="3">LED mode = [01]</th> </tr> <tr> <th>Link</th> <th>Pin State</th> <th>LED Definition</th> </tr> </thead> <tbody> <tr> <td>No Link</td> <td>H</td> <td>OFF</td> </tr> <tr> <td>Link</td> <td>L</td> <td>ON</td> </tr> </tbody> </table> <p>LED mode = [10] Reserved</p> <p>LED mode = [11] Reserved</p>	LED mode = [00]			Link/Activity	Pin State	LED Definition	No Link	H	OFF	Link	L	ON	Activity	Toggle	Blinking	LED mode = [01]			Link	Pin State	LED Definition	No Link	H	OFF	Link	L	ON
LED mode = [00]																														
Link/Activity	Pin State	LED Definition																												
No Link	H	OFF																												
Link	L	ON																												
Activity	Toggle	Blinking																												
LED mode = [01]																														
Link	Pin State	LED Definition																												
No Link	H	OFF																												
Link	L	ON																												
31	LED1 / SPEED	Ipu/O	<p>LED Output: Programmable LED1 Output / Config Mode: Latched as SPEED (register 0h, bit 13) during power-up / reset. See “Strapping Options” section for details. The LED1 pin is programmable via register 1Eh bits [15:14], and is defined as follows.</p> <table border="1"> <thead> <tr> <th colspan="3">LED mode = [00]</th> </tr> <tr> <th>Speed</th> <th>Pin State</th> <th>LED Definition</th> </tr> </thead> <tbody> <tr> <td>10BT</td> <td>H</td> <td>OFF</td> </tr> <tr> <td>100BT</td> <td>L</td> <td>ON</td> </tr> </tbody> </table> <table border="1"> <thead> <tr> <th colspan="3">LED mode = [01]</th> </tr> <tr> <th>Activity</th> <th>Pin State</th> <th>LED Definition</th> </tr> </thead> <tbody> <tr> <td>No Activity</td> <td>H</td> <td>OFF</td> </tr> <tr> <td>Activity</td> <td>Toggle</td> <td>Blinking</td> </tr> </tbody> </table> <p>LED mode = [10] Reserved</p> <p>LED mode = [11] Reserved</p>	LED mode = [00]			Speed	Pin State	LED Definition	10BT	H	OFF	100BT	L	ON	LED mode = [01]			Activity	Pin State	LED Definition	No Activity	H	OFF	Activity	Toggle	Blinking			
LED mode = [00]																														
Speed	Pin State	LED Definition																												
10BT	H	OFF																												
100BT	L	ON																												
LED mode = [01]																														
Activity	Pin State	LED Definition																												
No Activity	H	OFF																												
Activity	Toggle	Blinking																												
32	RST#	I	Chip Reset (active low)																											
PAD-DLE	GND	Gnd	Ground																											

NOTE:

- P = Power supply.
Gnd = Ground.
O = Output.
I/O = Bi-directional.
Ipd = Input with internal pull-down (40K +/-30%).
Ipu = Input with internal pull-up (40K +/-30%).
Opu = Output with internal pull-up (40K +/-30%).
Ipu/O = Input with internal pull-up (40K +/-30%) during power-up/reset; output pin otherwise.
Ipd/O = Input with internal pull-down (40K +/-30%) during power-up/reset; output pin otherwise.
- MII Rx Mode: The RXD[3..0] bits are synchronous with RXCLK. When RXDV is asserted, RXD[3..0] presents valid data to MAC through the MII. RXD[3..0] is invalid when RXDV is de-asserted.
- RMII Rx Mode: The RXD[1:0] bits are synchronous with REF_CLK. For each clock period in which CRS_DV is asserted, two bits of recovered data are sent from the PHY.
- MII Tx Mode: The TXD[3..0] bits are synchronous with TXCLK. When TXEN is asserted, TXD[3..0] presents valid data from the MAC through the MII. TXD[3..0] has no effect when TXEN is de-asserted.
- RMII Tx Mode: The TXD[1:0] bits are synchronous with REF_CLK. For each clock period in which TX_EN is asserted, two bits of data are received by the PHY from the MAC.

12.2.20. Main Board Section

3.3V / 1.2V Troubleshooting Guide (1)

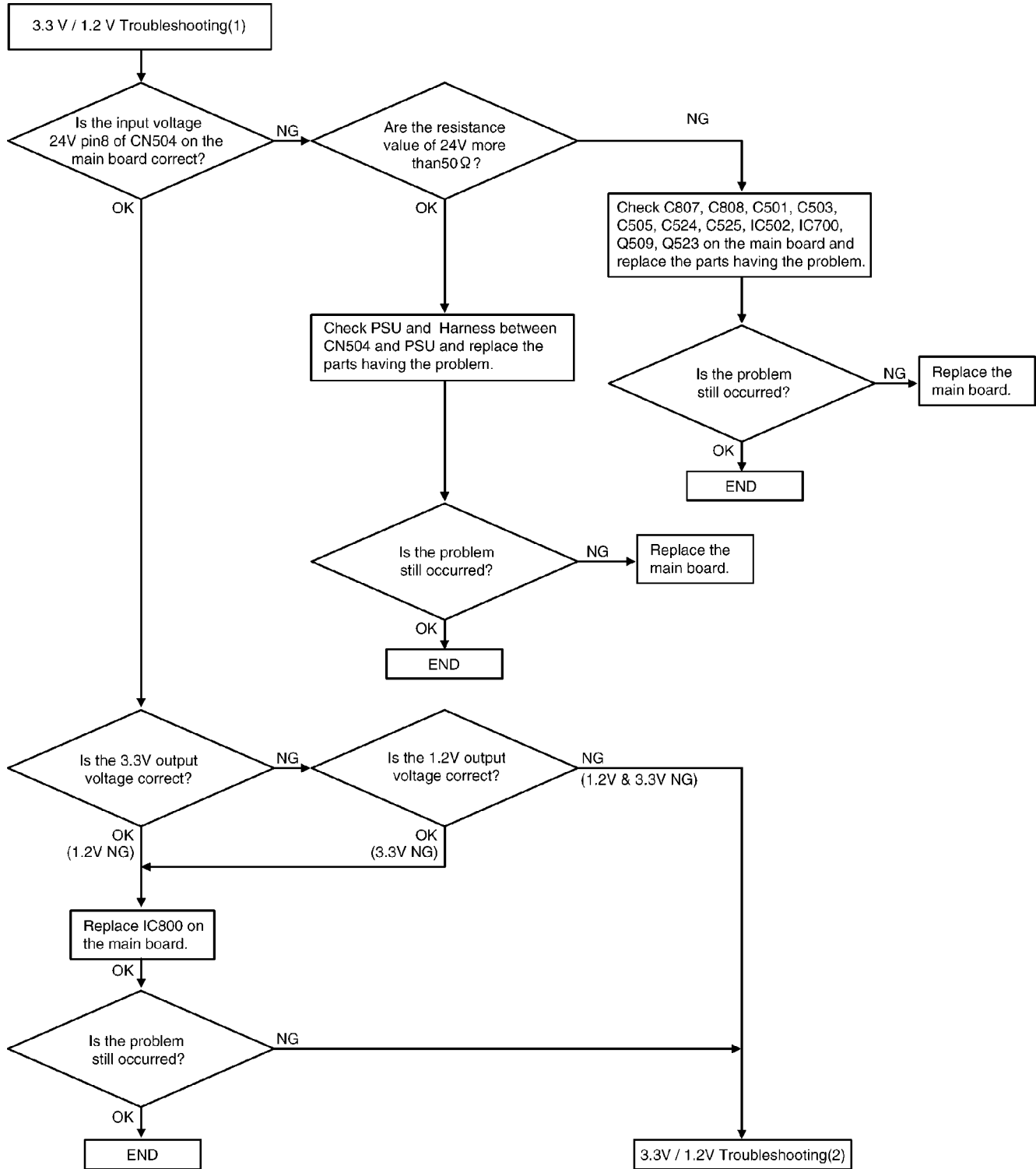

3.3V / 1.2V Troubleshooting Guide (2)

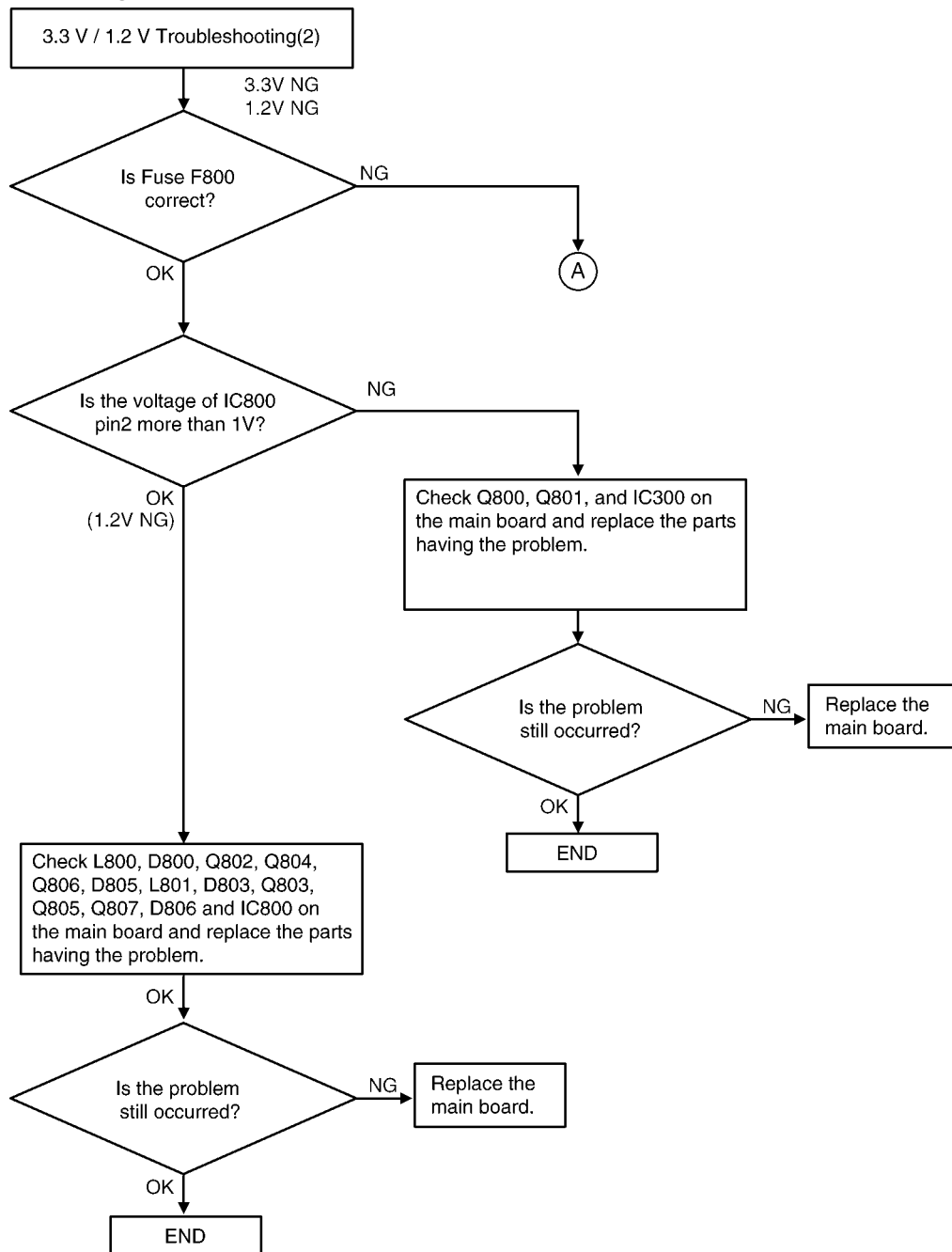

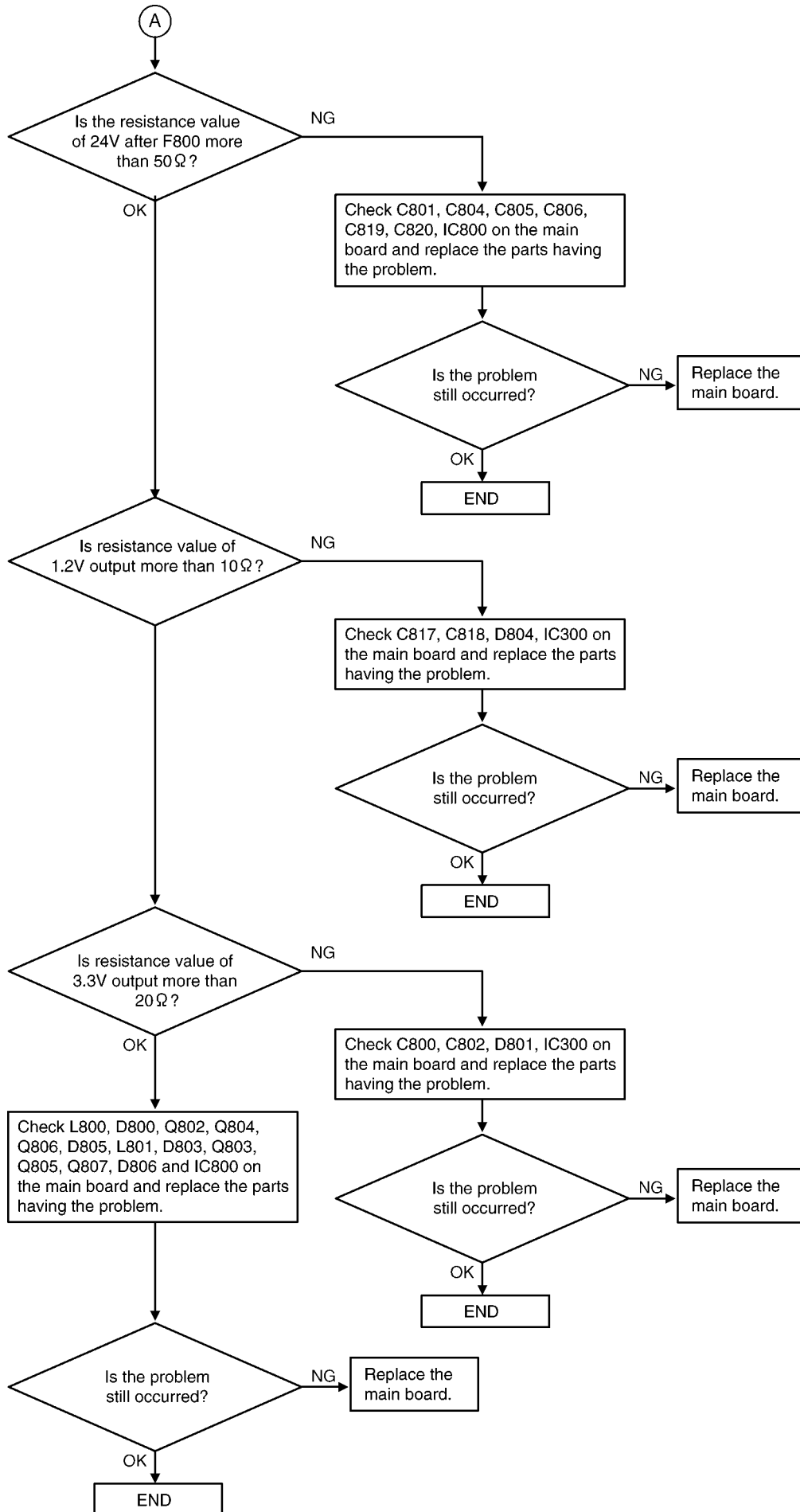

12.2.21. Power Supply Board Section

12.2.21.1. Key Components For Troubleshooting

Check the following parts first: F1, F2, D1, C5, Q1 and PC1.

This comes from our experience with experimental test. For example: power supply and lightning surge voltage test, with standing voltage test, intentional short circuit test, etc.

Caution:

If you find a melted fuse in the unit, do not turn on the power until you located and repair the faulty parts (except for the fuse); otherwise the fuse will melt again and you cannot pinpoint the faulty point.

In most cases, the symptom is that nothing is output. It is more likely that the fault is in the primary side rather than the secondary side. Check the primary side first.

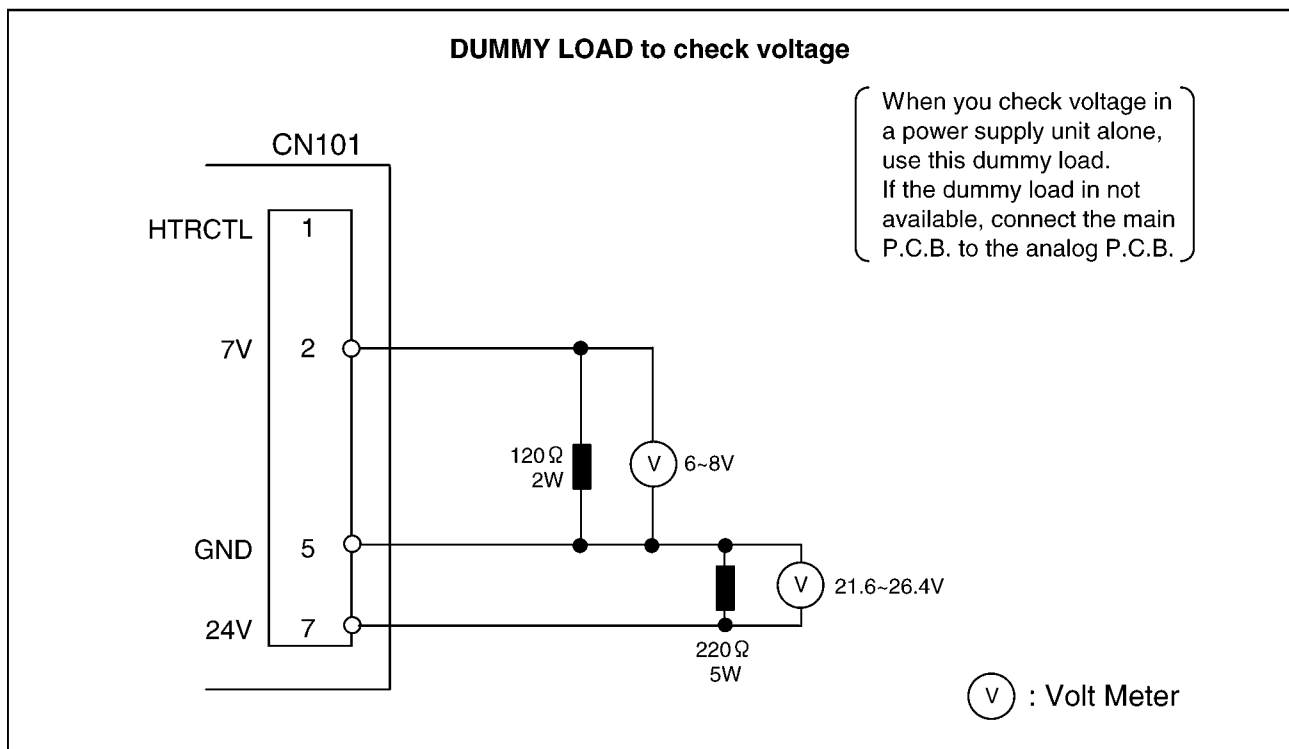
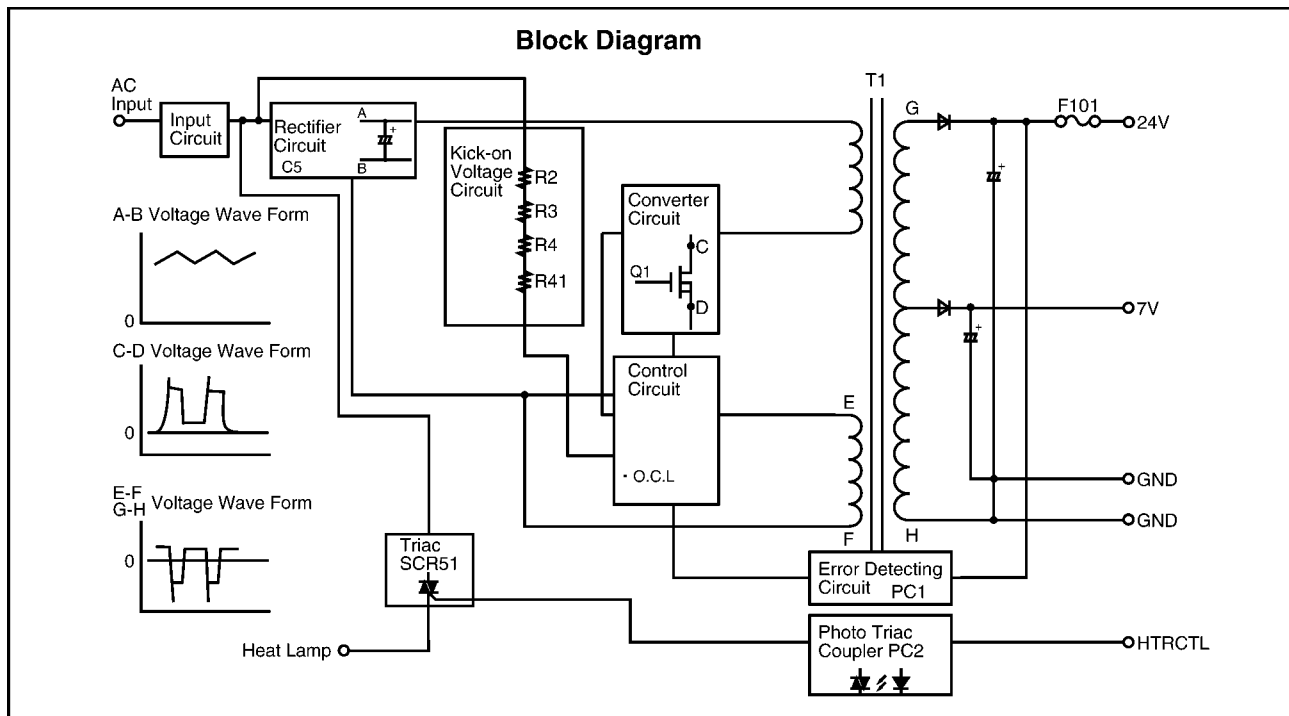

12.2.21.2. Troubleshooting Flow Chart

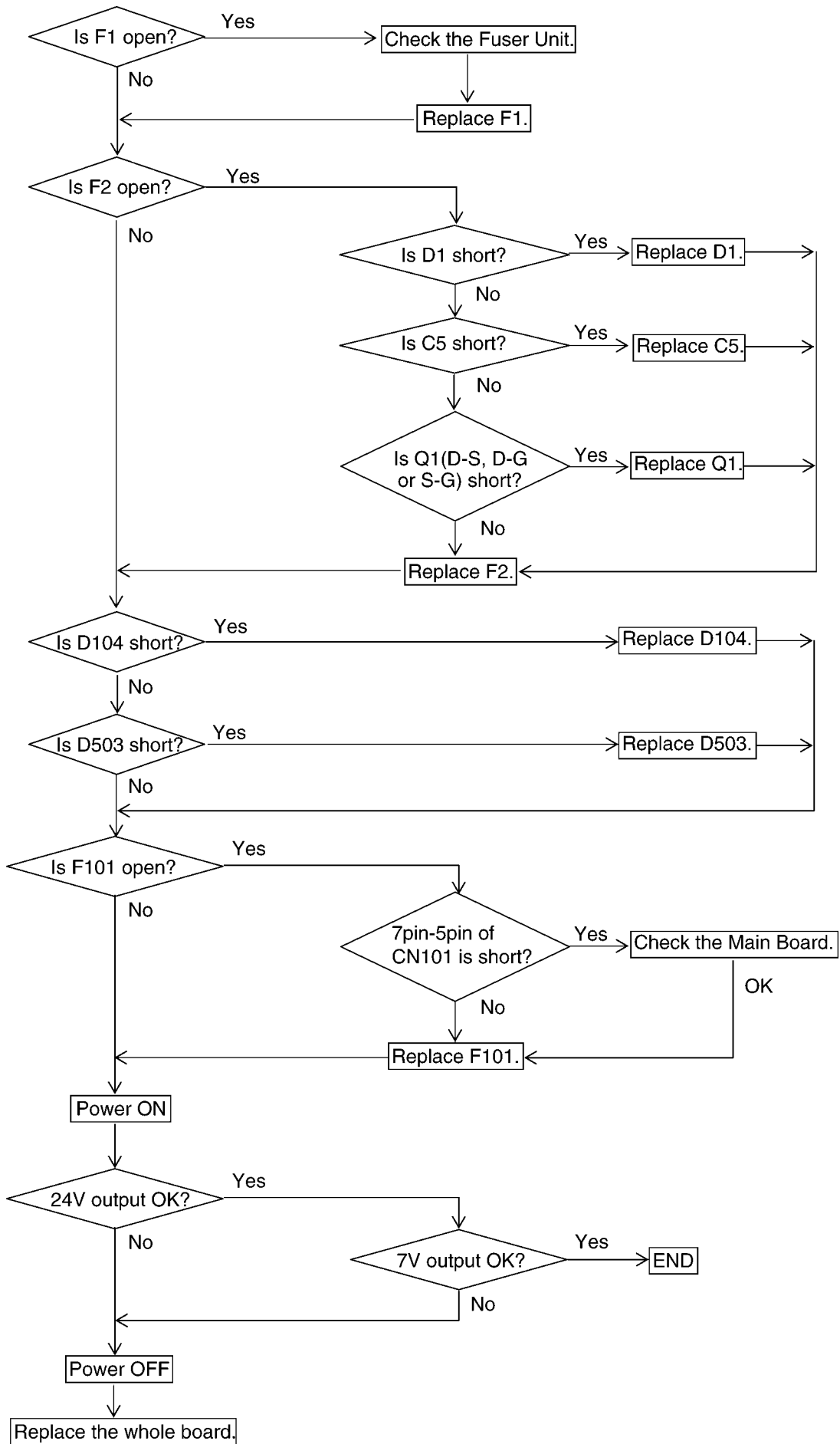

12.2.21.3. Broken Parts Repair Details

(D1)

If D1 is short-circuit, F2 will melt (open).

In this case, replace all of the parts (D1, F2).

(C5)

If overvoltage(Approx. 450V) was supplied for a power supply unit, C5 will be broken.

(Q1)

If Q1 is short-circuit, F2 will melt (open).

In this case, replace all of the parts (F2, Q1,D1).

(F101)

If F101 is melted (open), check the 24 Voltage line of the Main Board and others.

12.3. DOCUMENT JAMS (AUTO DOCUMENT FEEDER) (KX-MB2010 ONLY)

Caution:

- Do not pull out the jammed document forcibly before lifting the ADF cover.

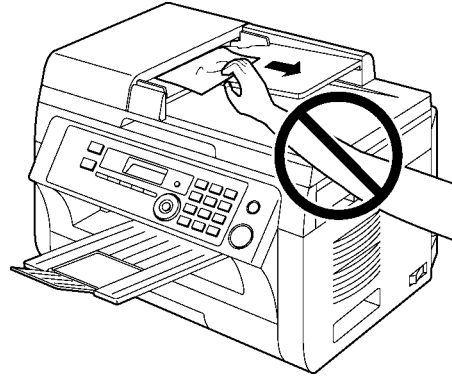

1. Open the ADF cover (1) while holding the document cover (2).

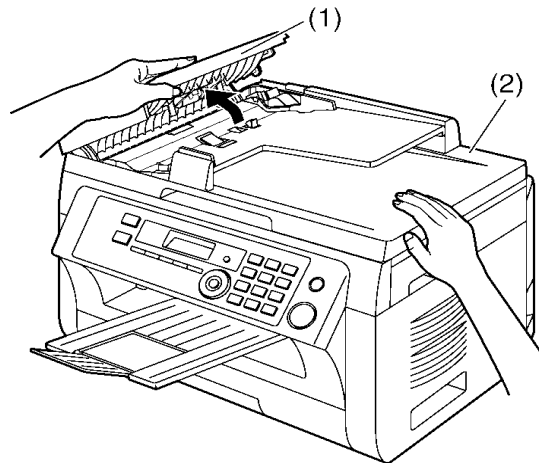

2. Remove the jammed document (3) carefully.
When the document has jammed near the document entrance:

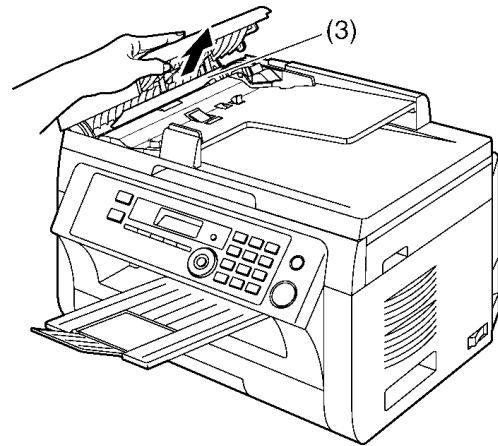

When the document has jammed near the document exit:

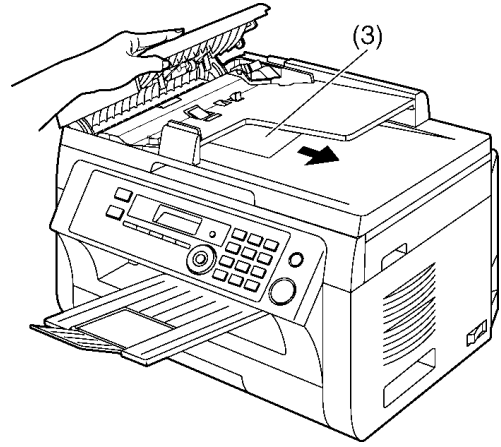

3. Close the ADF cover.

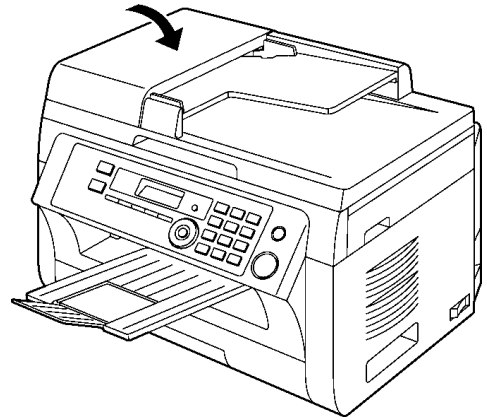

12.4. RECORDING PAPER JAM

Caution:

- Do not pull out the jammed paper forcibly before opening the top cover.

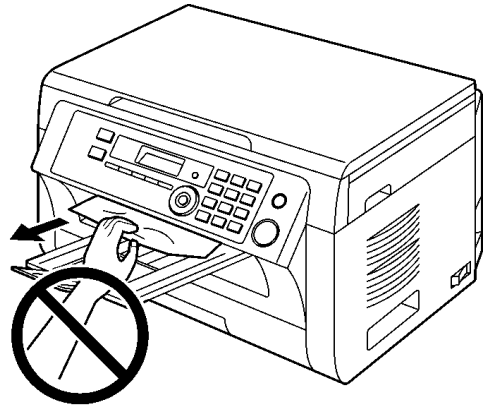

- To prevent injuries, be careful not to put your hands under the top cover.

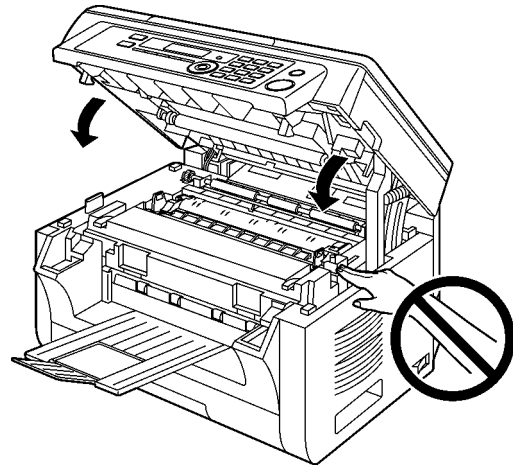

12.4.1. When the recording paper has jammed inside of the unit

The display will show the following.

PAPER JAMMED



OPEN TOP COVER

CHECK REAR COVER

Case 1:

When the recording paper has jammed near the manual input tray:

1. Pull open the paper input tray (1).

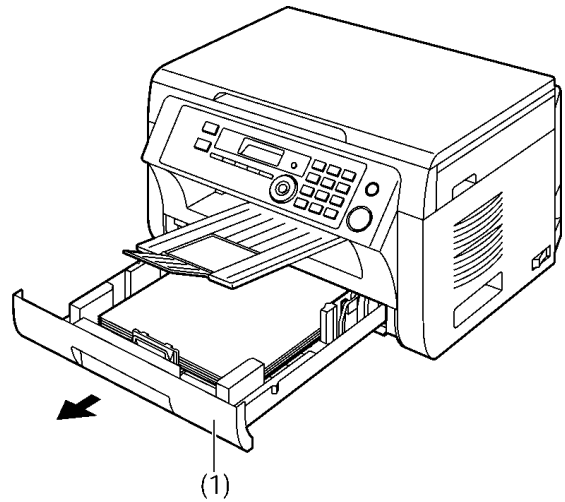

2. Open the manual input tray (2) and remove the jammed paper (3) carefully by pulling it upwards. Then close the manual input tray.

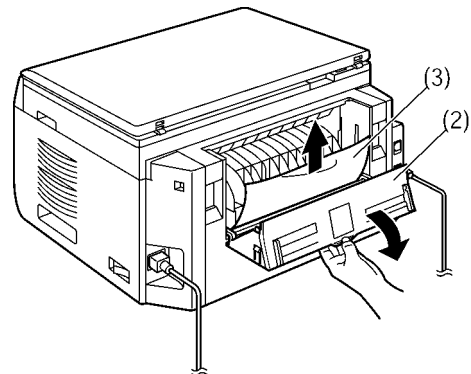

3. Close the paper input tray.
 - Open and close the top cover (4) to clear the message.

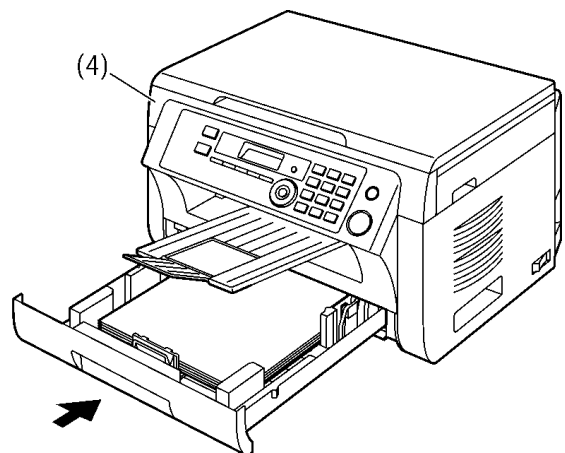

Case 2:

When the recording paper has jammed near the drum and toner cartridge:

1. Pull open the paper input tray (1).

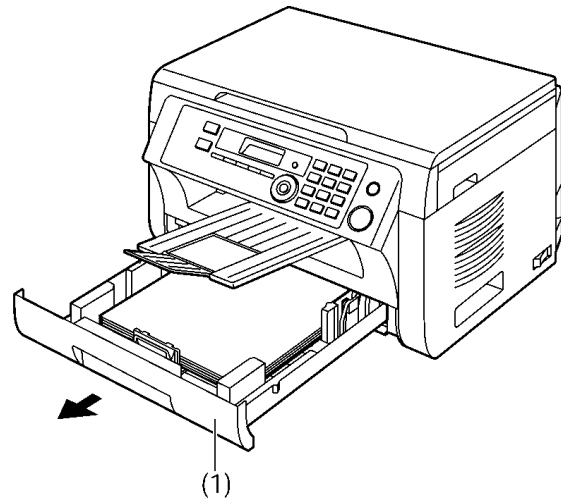

2. Open the top cover (2) by holding the indentations (3) on both sides of the unit.

Note:

- Do not touch the transfer roller (5)

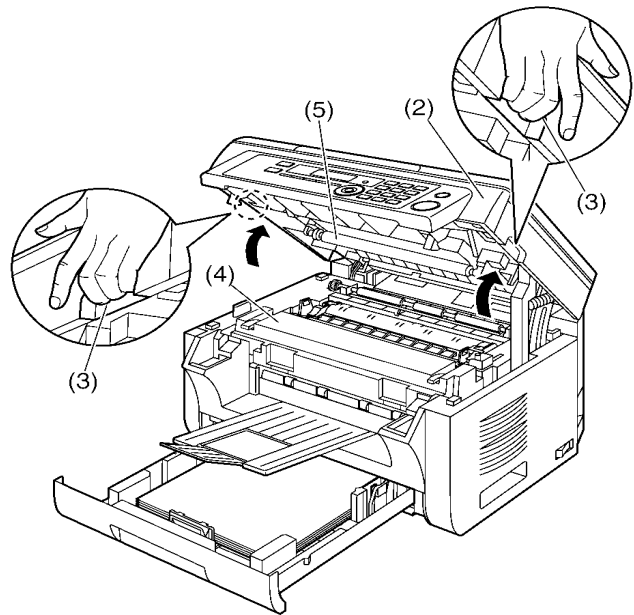

Caution:
The fuser unit (4) gets hot. Do not touch it.

3. Remove the jammed paper (6) carefully by pulling it upwards.

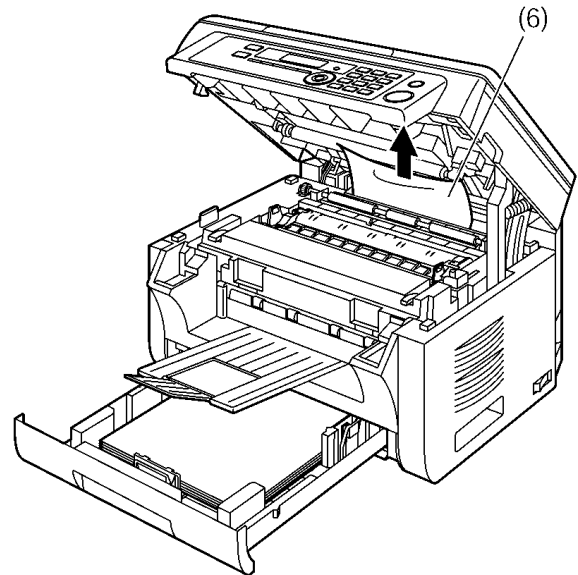

Remove the jammed paper (7) carefully by pulling it toward you.

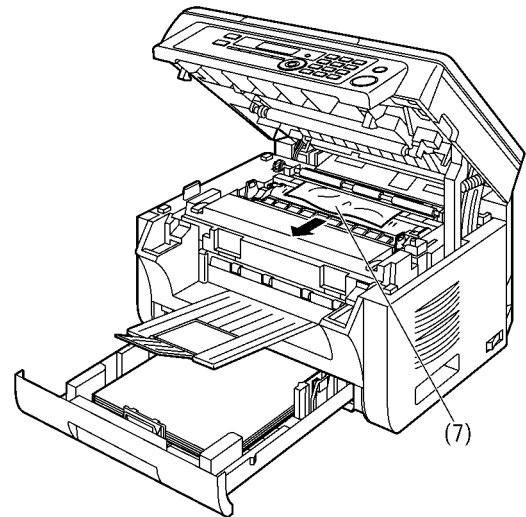

4. Close the paper input tray.

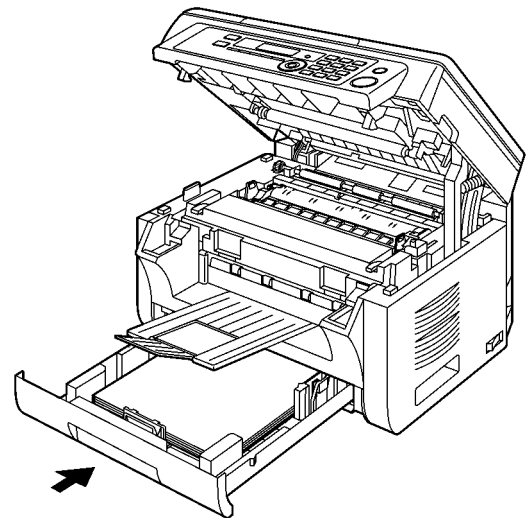

5. Close the top cover by holding the indentations on both sides of the unit, until locked.

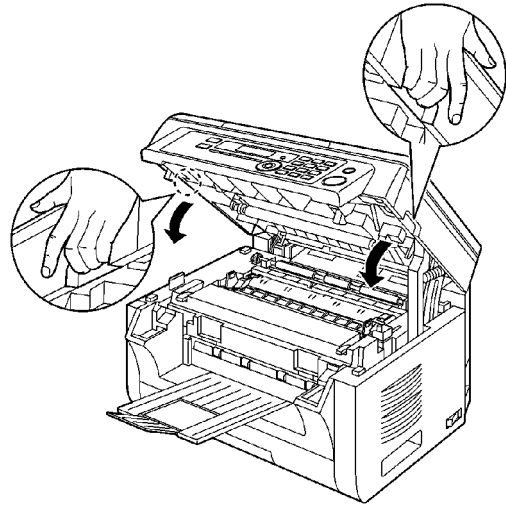

Case 3:

When the recording paper has jammed near the fuser unit:

1. Open the top cover (1) by holding the indentations (2) on both sides of the unit.

Note:

- Do not touch the transfer roller (4).

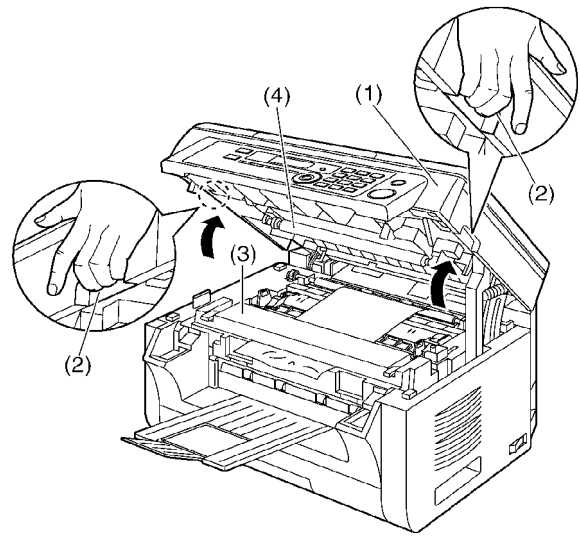

Caution:
The fuser unit (3) gets hot. Do not touch it.

2. Lift both green levers (5) until they stop.

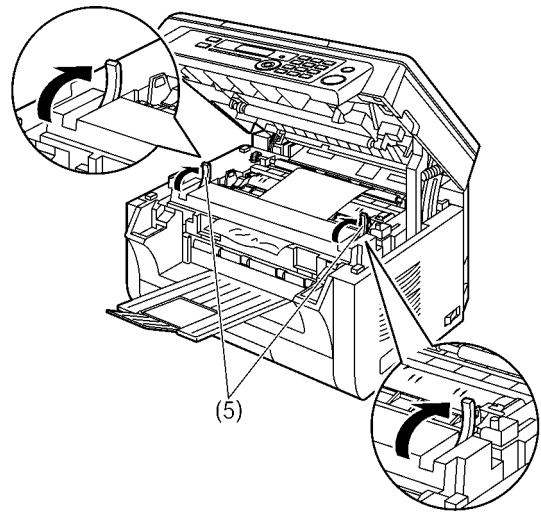

3. Remove the jammed paper (6) carefully by pulling it upwards.

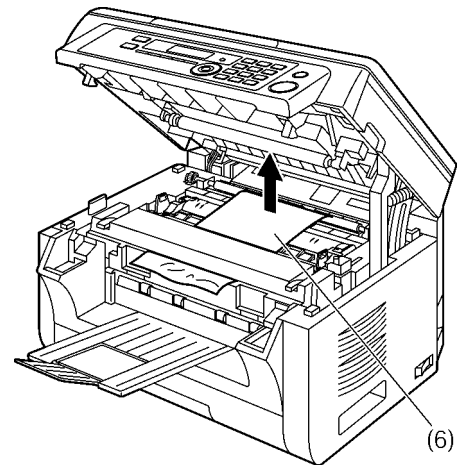

4. Push back the green levers (7) to the original position.

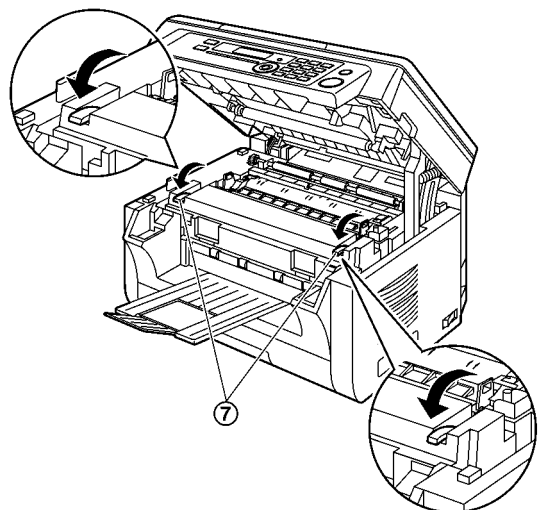

5. Close the top cover by holding the indentations on both sides of the unit, until locked.

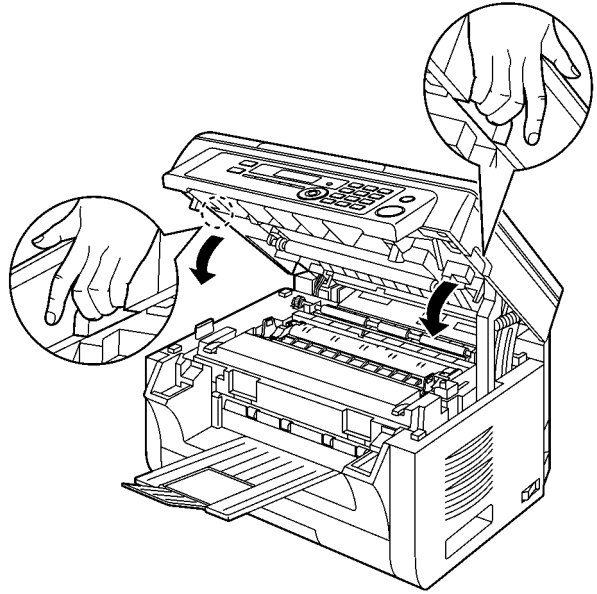

12.4.2. When the recording paper is not fed into the unit properly

The display will show the following.

CHECK PAPER #1 PRESS START

1. Pull the paper input tray until it clicks into place, then pull it completely out, lifting the front part of the tray. Remove the recording paper and straighten.
2. Re-load the recording paper.

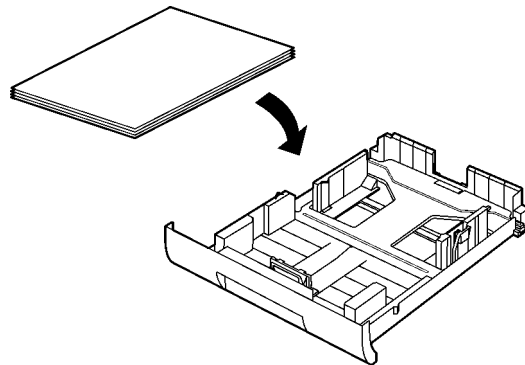

3. Insert the paper input tray into the unit, lifting the front part of the tray. Then push it completely into the unit.

Note:

- If the message is still displayed, check the recording paper specifications and load the recording paper again.

12.4.3. When the recording paper in the manual input tray is not fed into the unit properly

The display will show the following.

CHECK PICK UP INPUT TRAY #2

1. Remove the recording paper.
2. Re-insert the recording paper.

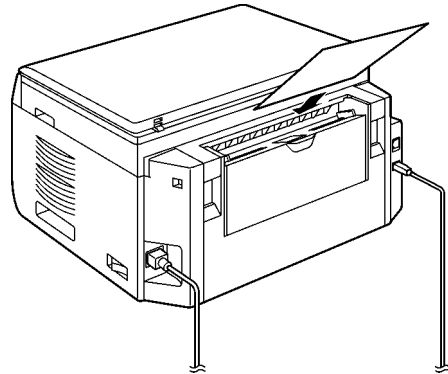

Note:

- If the message is still displayed, check the recording paper specifications and re-install recording paper.

13 Service Fixture & Tools

How to extend cords

When extending cords, you need 2 pairs of A,B (A=connector,B=cord)
 (One pair is connected to the Main board.)
 If you do not have 2 pairs, order the necessary parts.

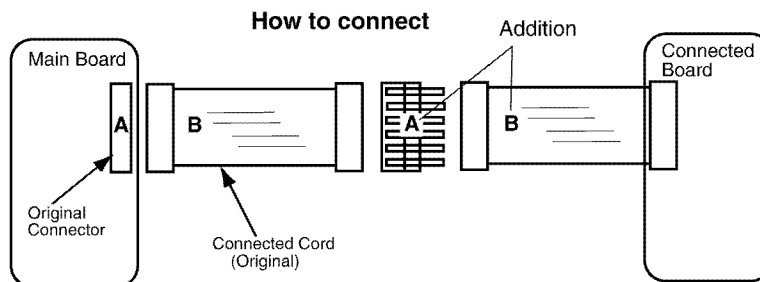

NOTE

Be sure if the direction of the connectors are correct.

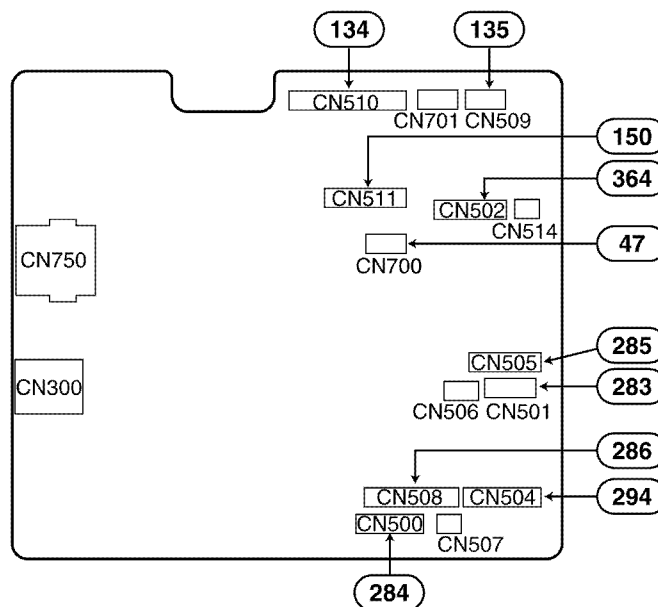
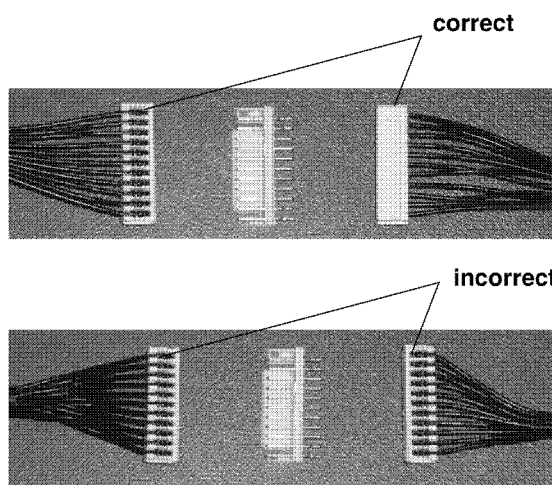

14 Disassembly and Assembly Instructions

Note:

Remove the Document Cover, the Paper Input tray and the drum and toner cartridge before reassembling.

First of all

Before disassembling, do the following things.

- (1) Pull the Paper Input Tray until it clicks into place, then pull it completely out, lifting the front part of the tray.
- (2) Take the Drum and Toner unit out by holding the tabs.

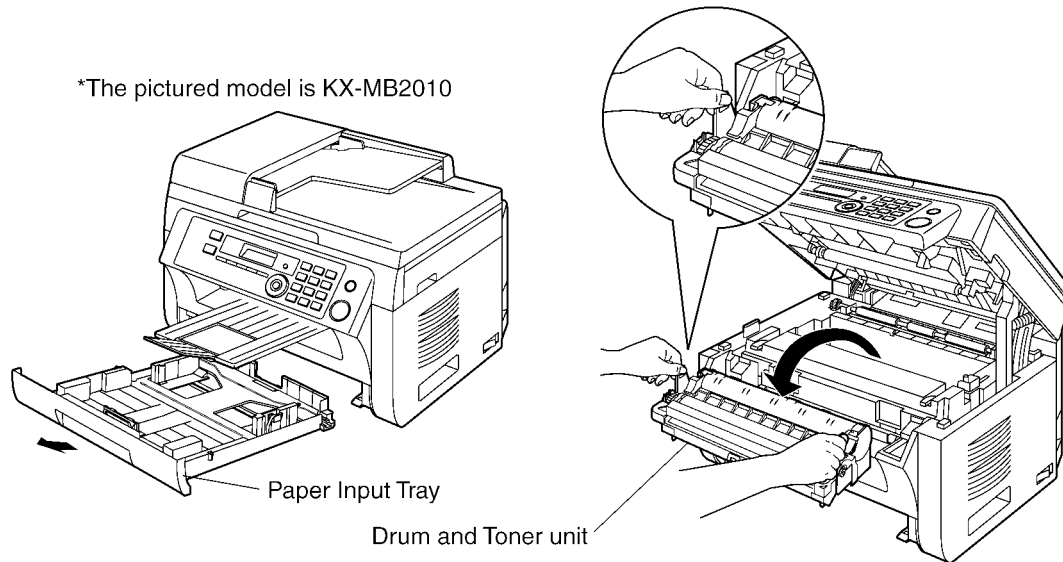

GENERAL SECTION

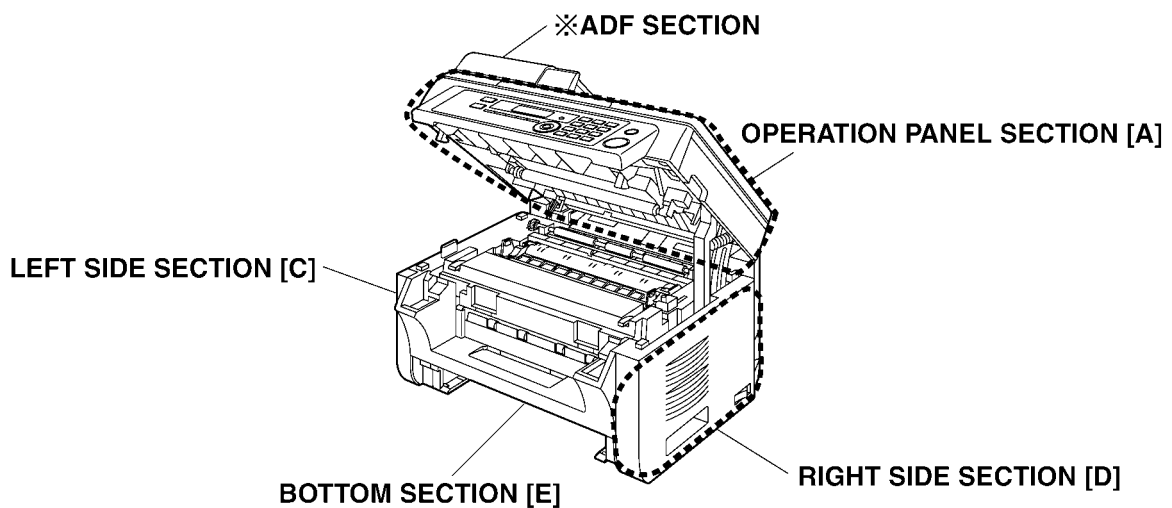

※Regarding ADF SECTION, refer to the service manual for KX-MB781/782/783 series

14.1. Bottom Section

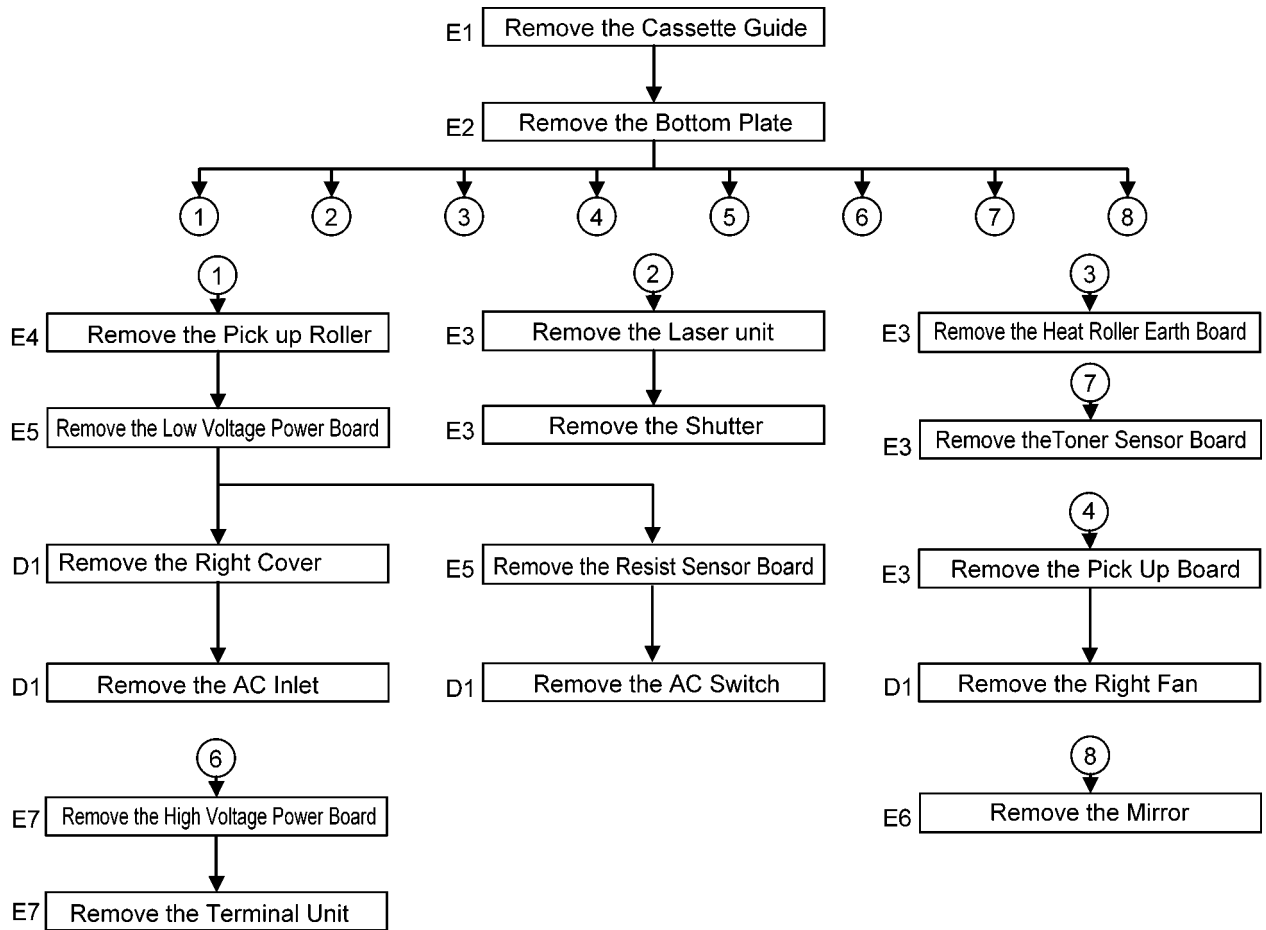

14.2. Left Side Section

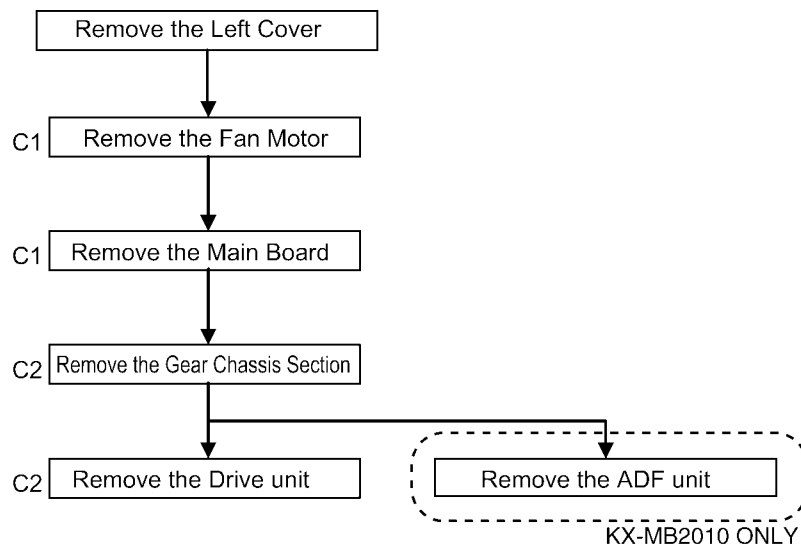

14.3. Operation Panel Section

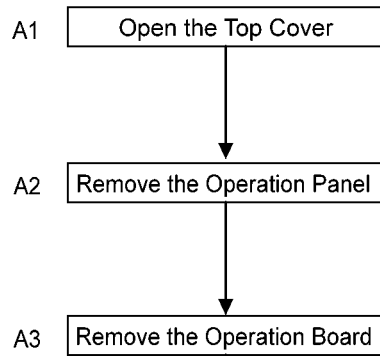

14.4. Open Top Cover

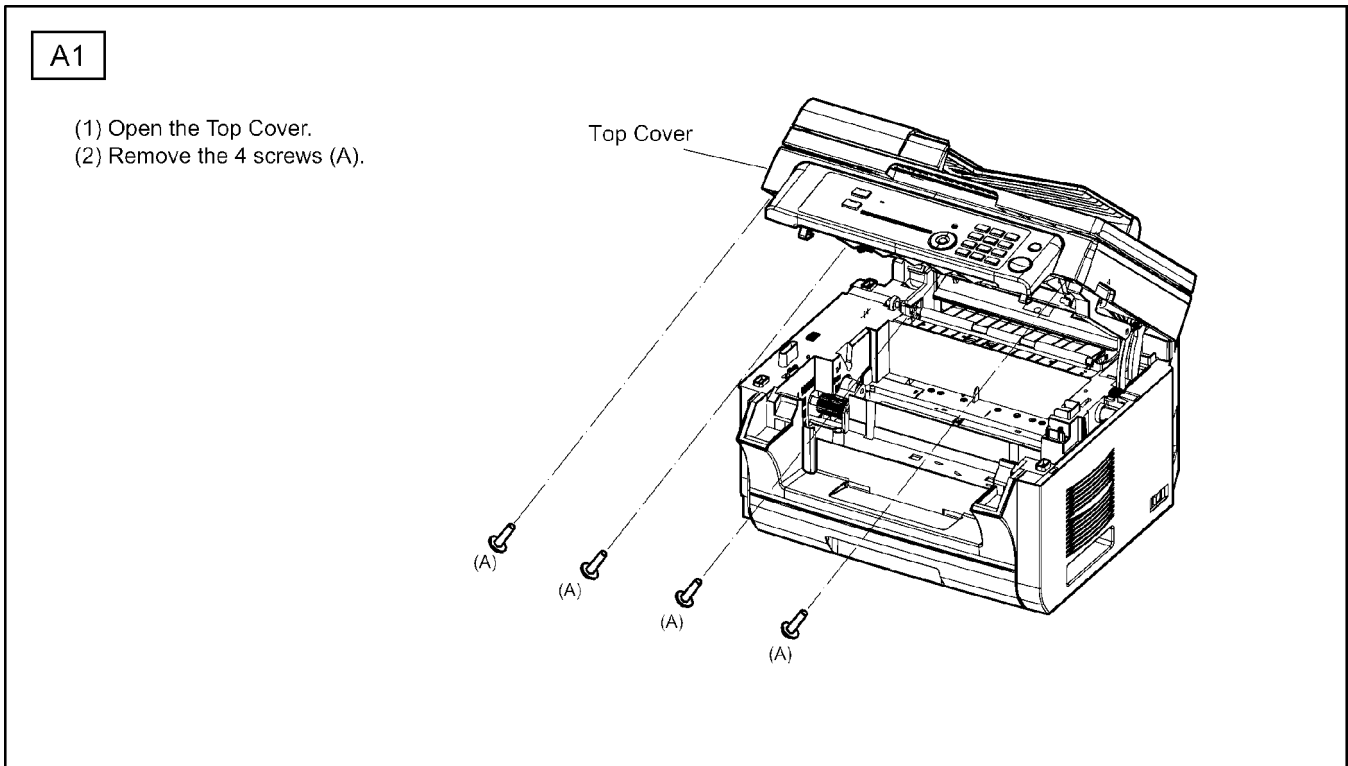

14.5. Remove Operation Panel

A2

- (1) Remove the Front Cover.
- (2) Remove the Operation Panel.
- (3) Remove the connector.

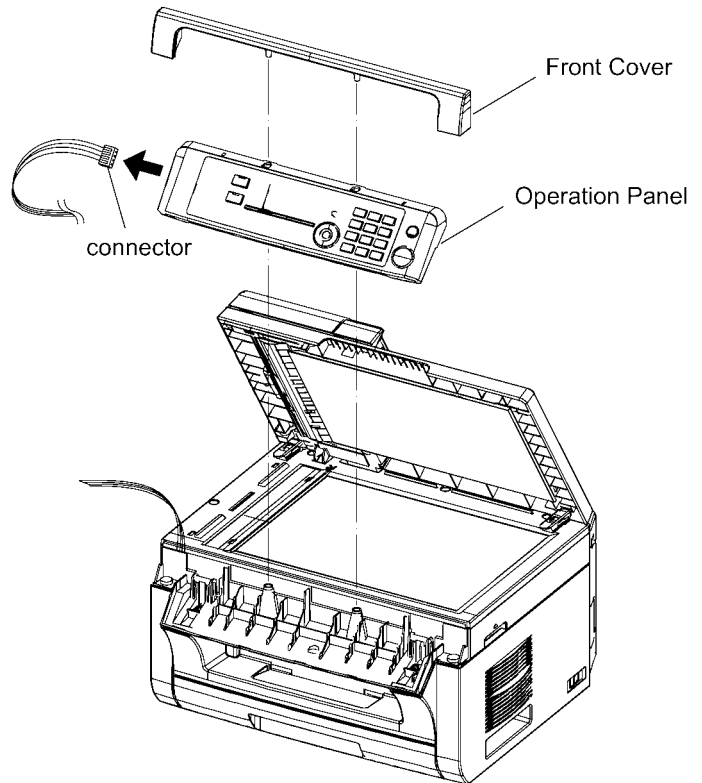

14.6. Remove Operation Board

A3

- (1) Remove the 2 screws (A).
- (2) Push the Hooks to remove the Operation Board.
- (3) Remove the connector.

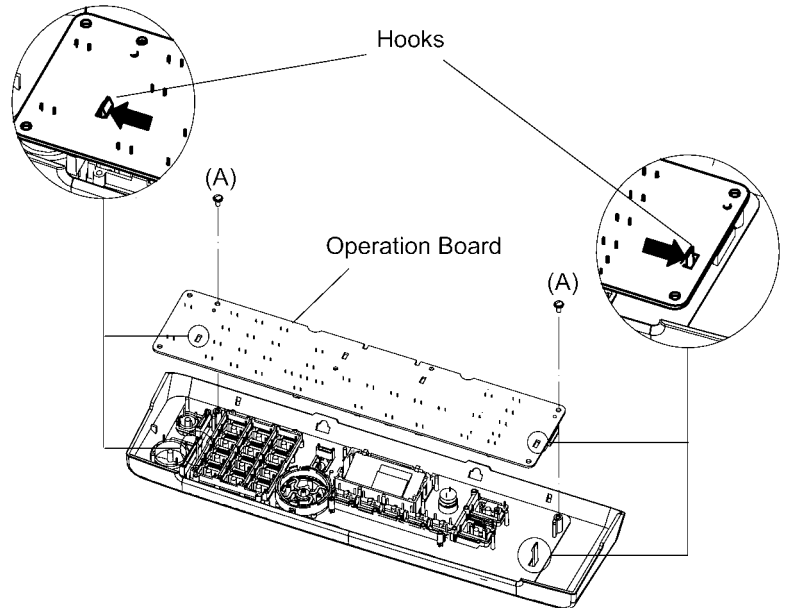

14.7. Remove Main Board

C1

Left Cover

- (1) Remove the 4 screws (A).
- (2) Remove the 3 Hooks (B).

Fan Motor

- (3) Remove the Fan Motor.

Main Board

- (3) Remove the 4 screws (C).
- (4) Remove the all connectors on the Main Board.
- (5) Remove the Main Board.
- (6) Unsolder the Lithium Battery.

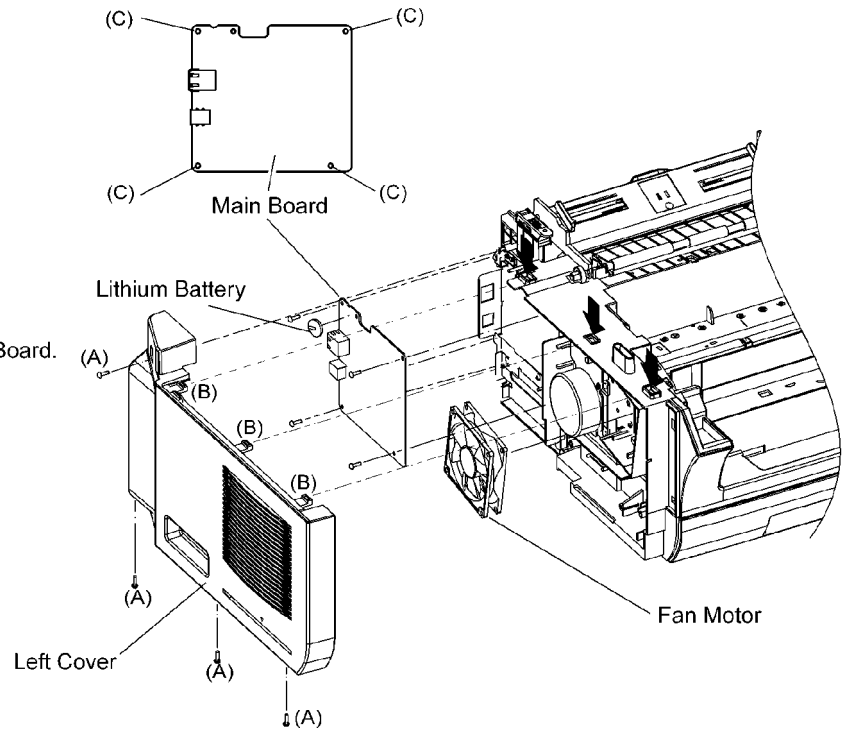

14.8. Remove Gear Chassis Section

C2

- (1) Remove the 4 screws (F)-a.
- (2) Remove the Motor unit.
- (3) Remove the 4 screws (F)-a.
- (4) Remove the Protect Cover.
- (5) Remove the 2 screws (F)-c.
- (6) Remove the 2 screws (J)-a.
- (7) Remove the Cover Plate.
- (8) Remove the 2 screws (F)-d.
- (9) Remove the 6 screws (J)-b (The CH mark).

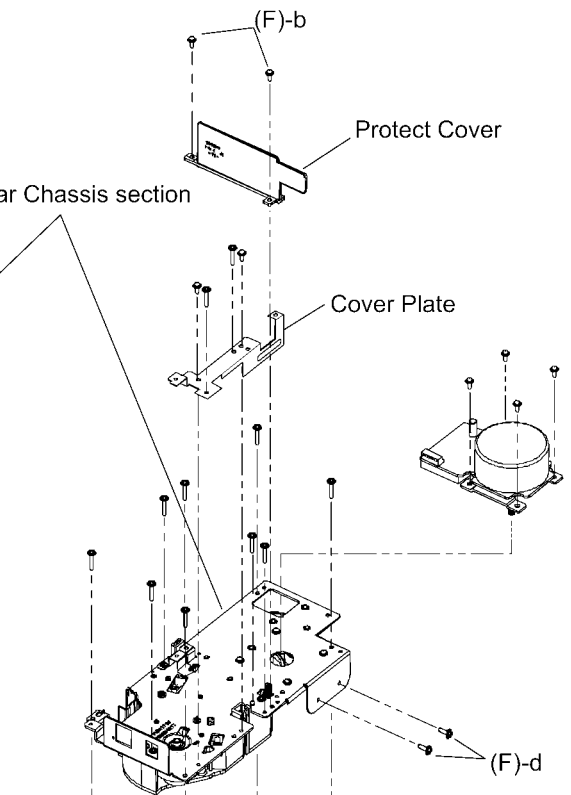
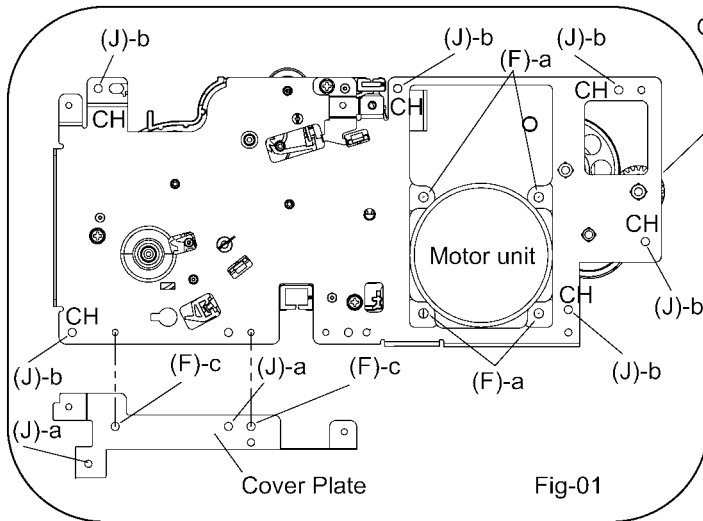

- (10) Remove the 3 screws (J)-c (The CS mark).
- (11) Remove the Protection Sheet.
- (12) Remove the Gear section.

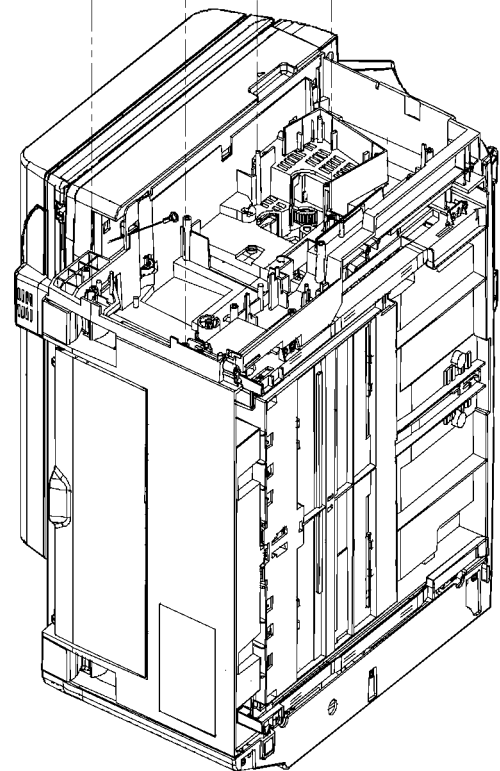
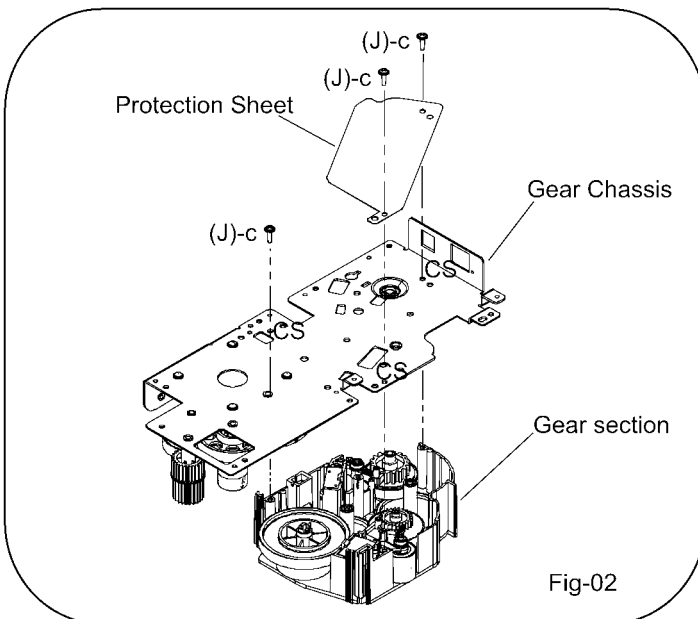

14.9. Remove Right Cover

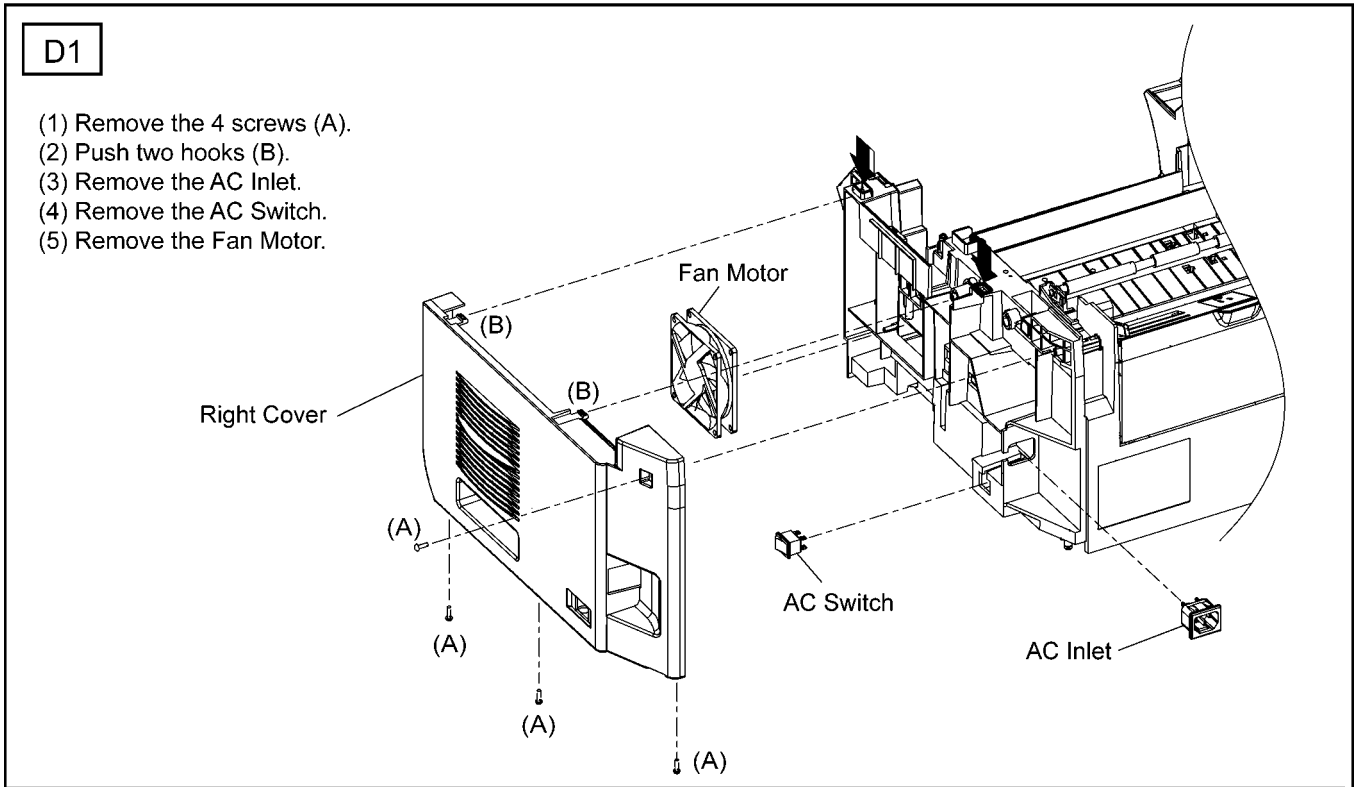

14.10. Remove Right Cassette Guide

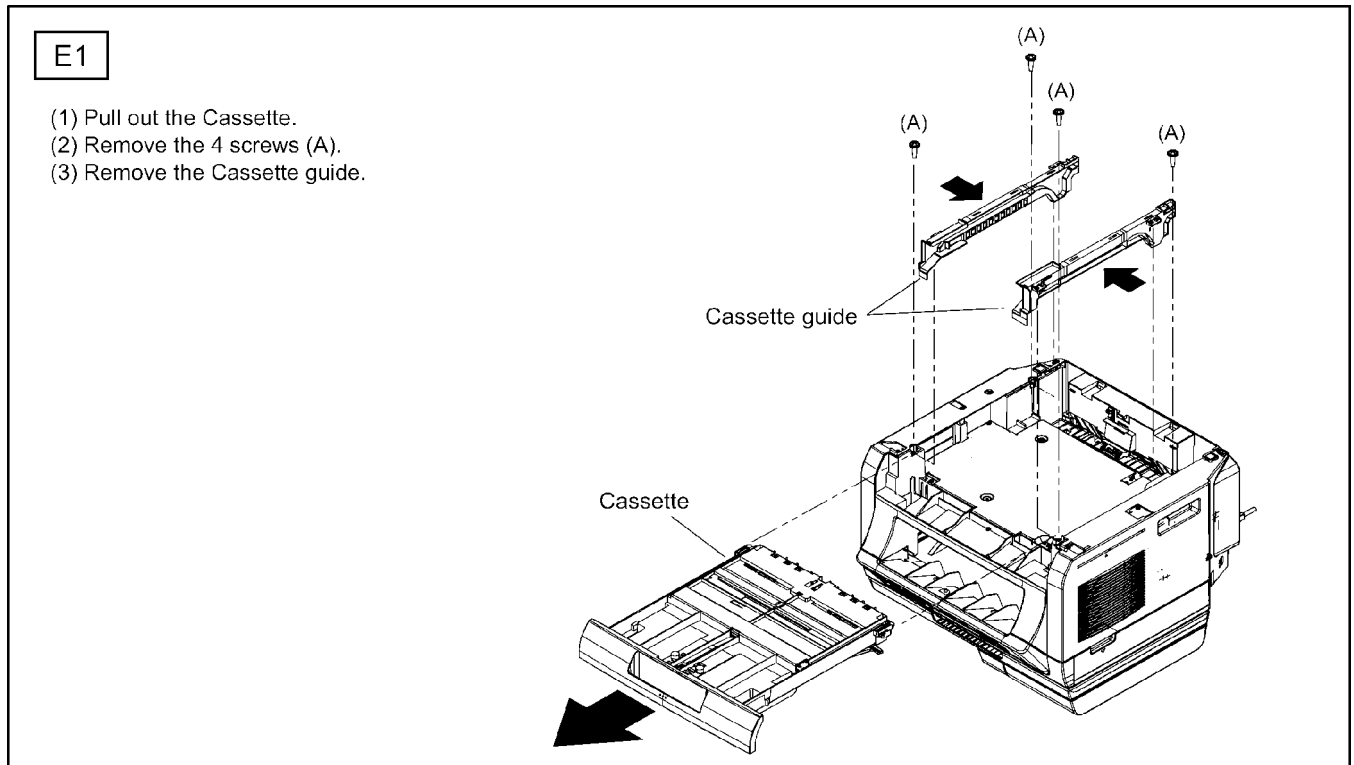

14.11. Remove Bottom Plate

E2

- (1) Remove the 6 screws (A).
- (2) Remove the 4 screws (B).
- (3) Remove the Bottom Plate.

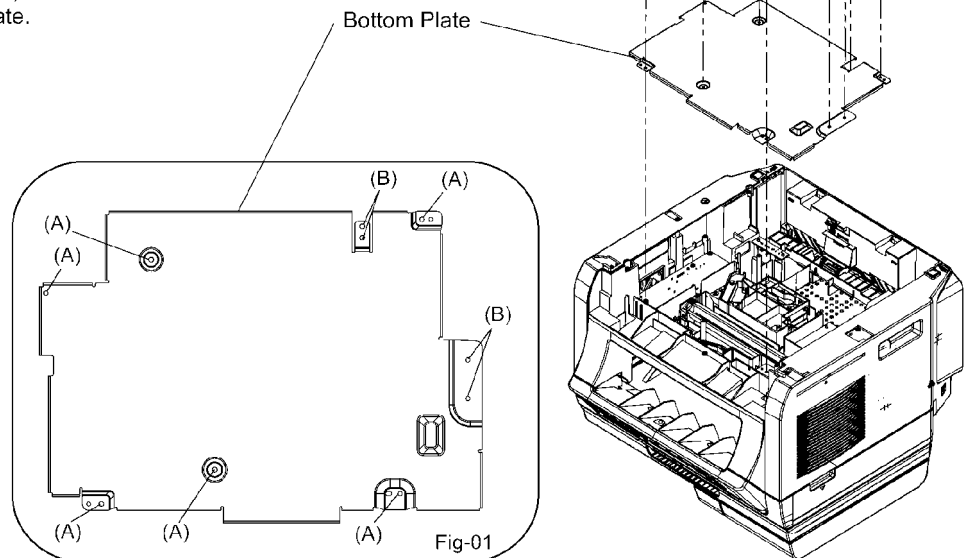

14.12. Remove Laser Unit

E3

Laser Unit & Shutter

- (1) Remove the 3 screws (A)-a.
- (2) Remove the leads connecting to Laser unit.
- (3) Remove the Laser unit.
- (4) Remove the Shutter.

Pick Sensor Board

- (1) Remove the screw (A)-b.
- (2) Remove all the connectors on the Pick Sensor Board.
- (3) Remove the Sensor Board.

Heat Roller Earth Board

- (1) Remove the screw (A)-c.
- (2) Remove the Heat Roller Earth Board.

Toner Sensor Board

- (1) Remove the screw (A)-d.
- (2) Remove the Toner Sensor Board.

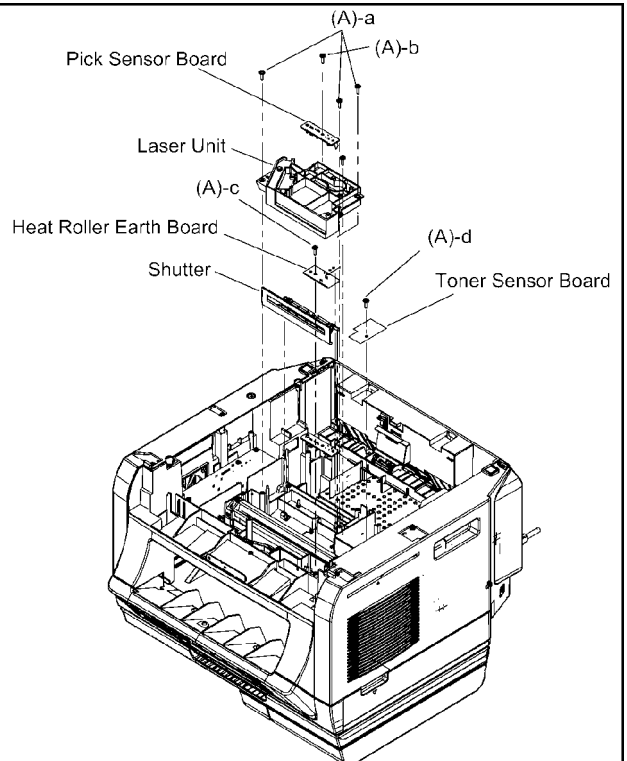

14.13. Remove Pick up Roller

E4

Pick-up-Roller-Holder

- (1) Remove the 2 screws (A)-a.
- (2) Remove the Pick-up-Roller-Holder.

Pick-up-Roller unit

- (3) Remove the 3 screws (A)-b.
- (4) Remove the Pick-up-Roller unit.

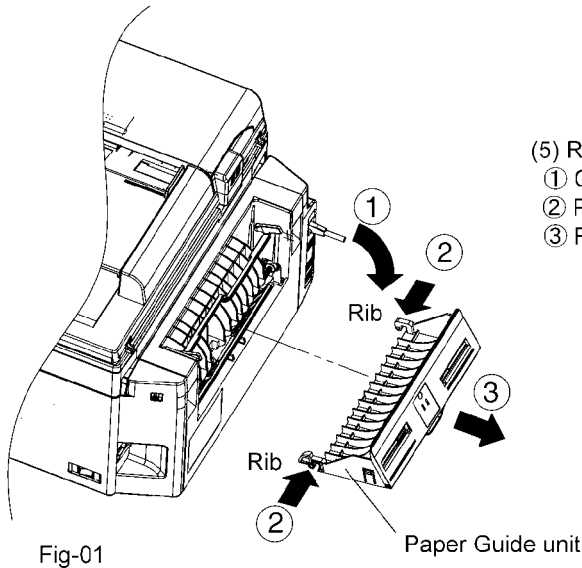
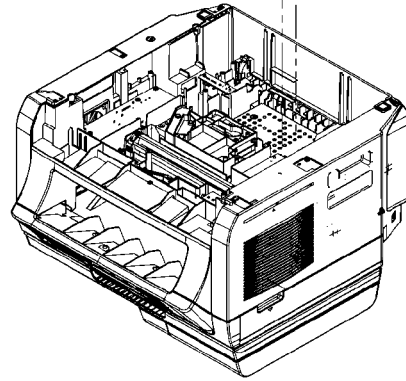
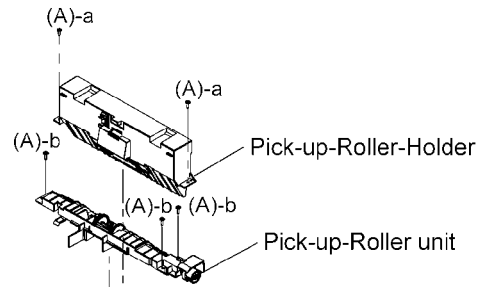

Fig-01

- (5) Remove the Paper Guide unit (Fig-01)

- ① Open the Paper Guide unit.
- ② Push the Rib on both sides lightly.
- ③ Remove the Paper Guide unit.

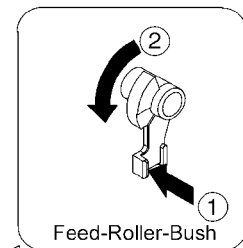
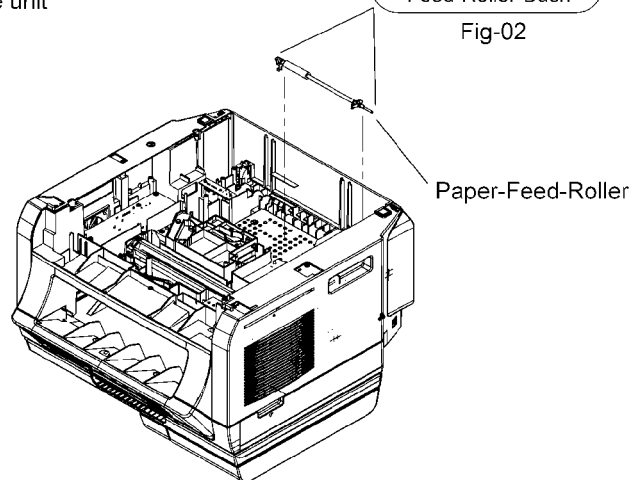

Fig-02

Paper-Feed-Roller

- (6) Remove the Paper Tray.
- ① Remove the Feed-Roller-Bush. (Fig-02)
- ② Remove the Paper-Feed-Roller.



14.14. Remove Low Voltage Power Board

E5

Low Voltage Power unit

- (1) Remove the 4 screws (A)-a.
- (2) Remove the screw (A)-b.
- (3) Remove the each connector.
- (4) Remove the Low Voltage Power unit.

- (4) --> Remove the 4 screws (A)-c to separate the power Board Cover from the Low Voltage Power Board.

Resist Sensor Cover

- (1) Remove the screw (B).
- (2) Remove the Resist Sensor Cover.

Resist Sensor Board

- (1) Remove the Resist Sensor Board.

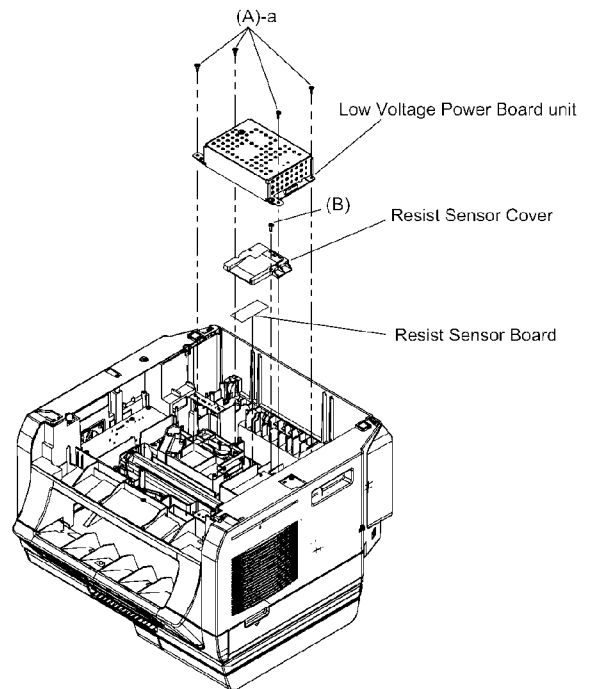
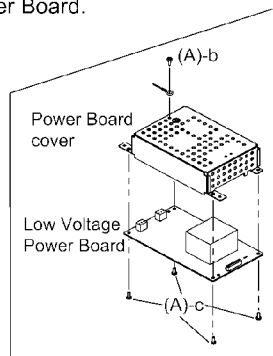

14.15. Remove Mirror

E6

- (1) Remove the Mirror Stopper.
- (2) Remove the Mirror 2.
- (3) Remove the Mirror LSU.
- (4) Remove the Mirror 1.

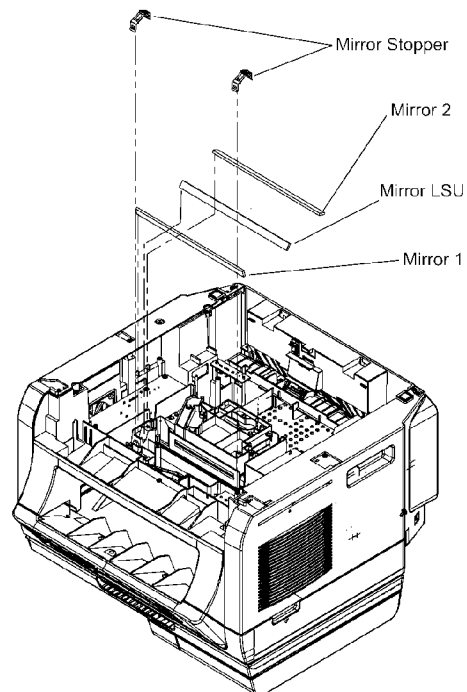

14.16. Remove High Voltage Power Board

E7

- (1) Remove the 6 screws (A)-a.
- (2) Remove the all the connectors on the High Voltage Power Board.
- (3) Remove the High Voltage Power Board.
- (4) Remove the 2 screws (A)-b.
- (5) Remove the Terminal unit.

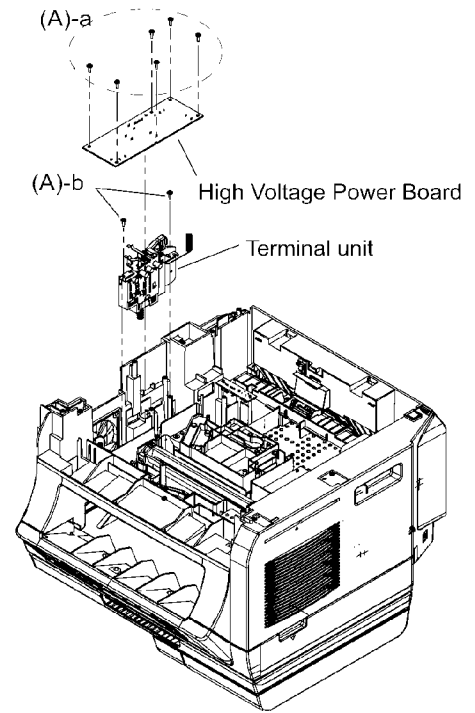

14.17. Installation Position of The Lead

14.17.1. Top Cover Section (1)

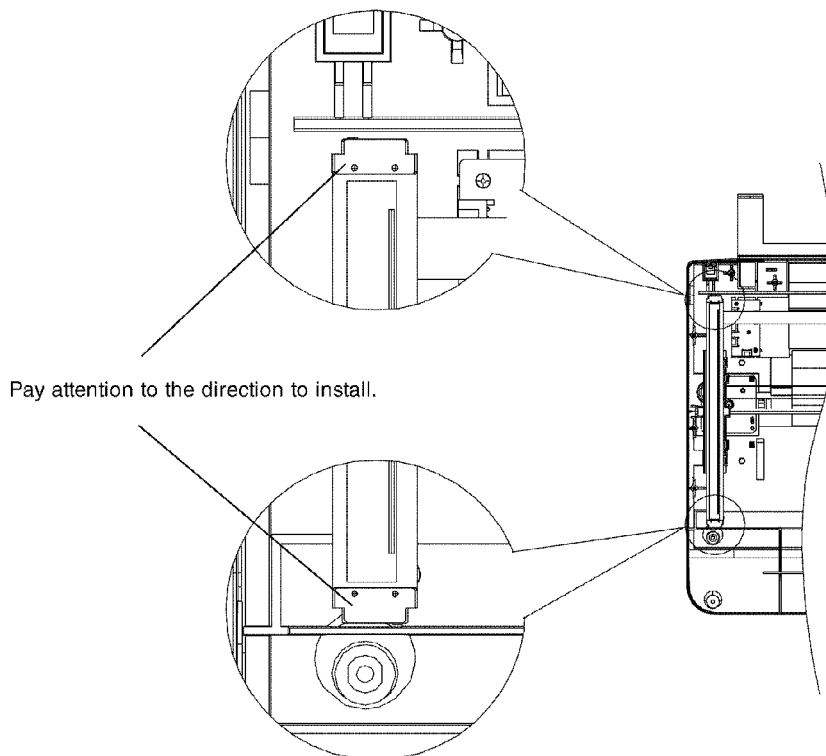
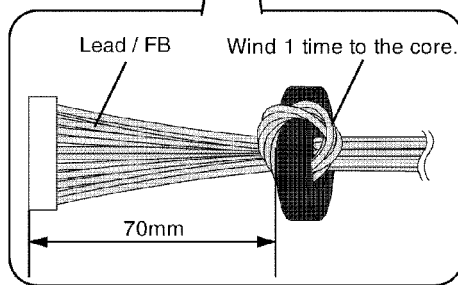
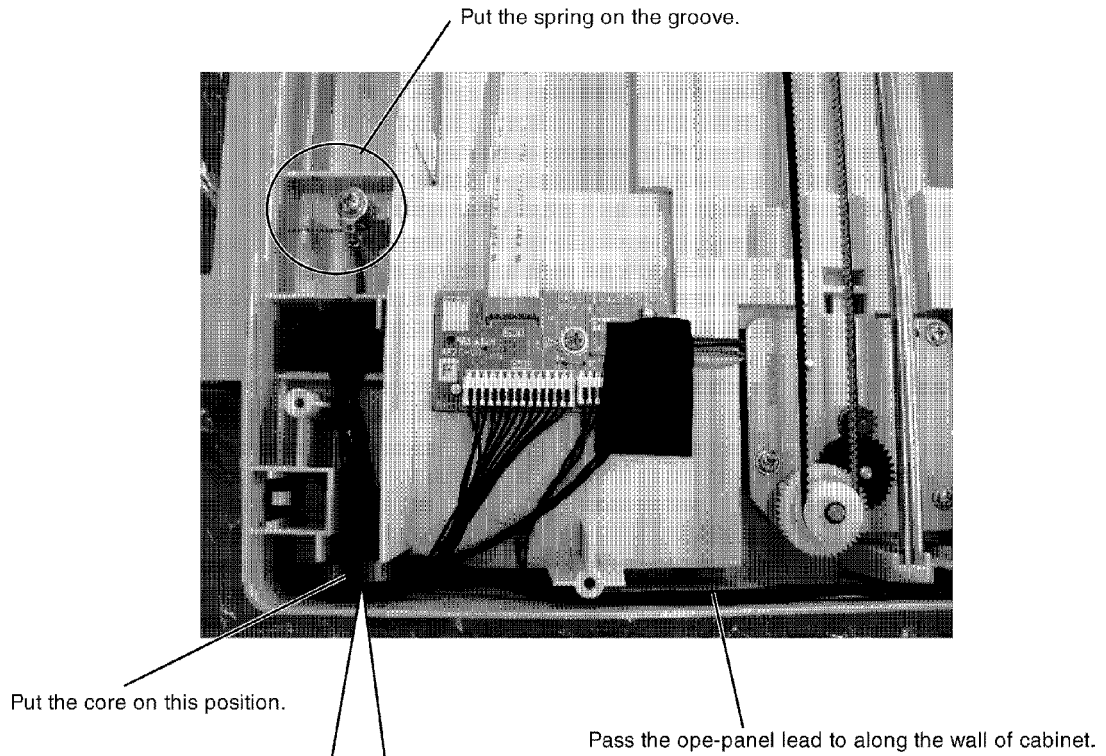

14.17.2. Top Cover Section (2)

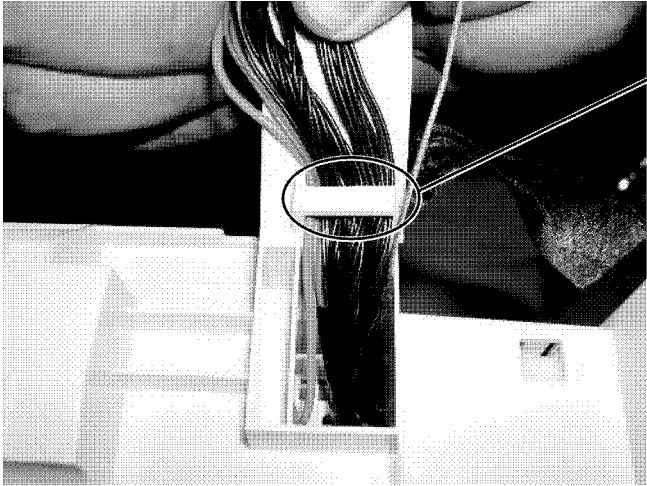

Hook the leads.
(Hook the lead from a little number.)
A wire is not hanging on a hook.

The wire must not twine.

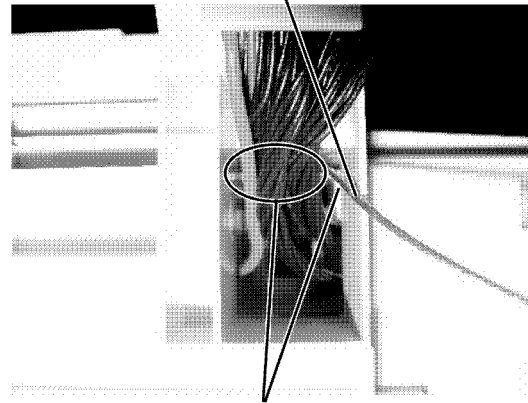

A wire is passing along the bottom
of all the leads.

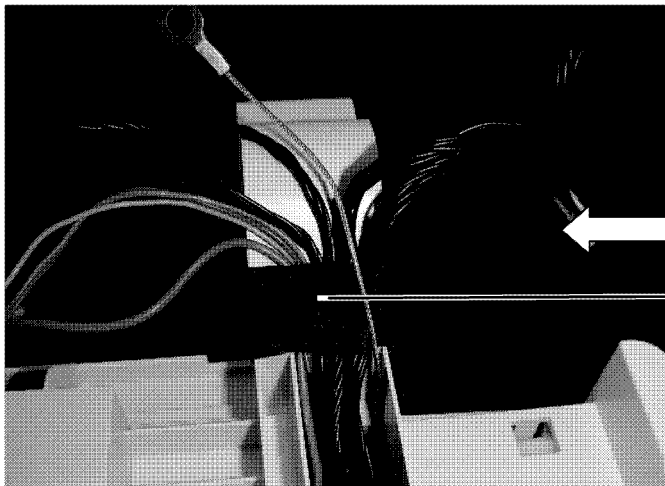

View A
Cover the leads completely with tape.
A wire is not taped together, either.

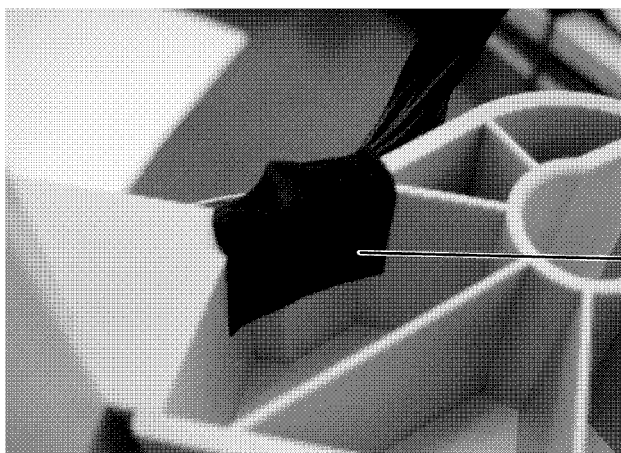

View A
Stick the tape according to the shape.

14.17.3. Top Cover Section (3)

Sample of Harness and Wire Arrangements

When the wire passes on the harness, the power of the shearing is applied to the harness.

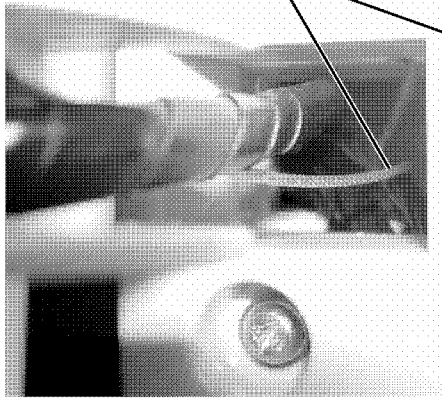

TOP VIEW

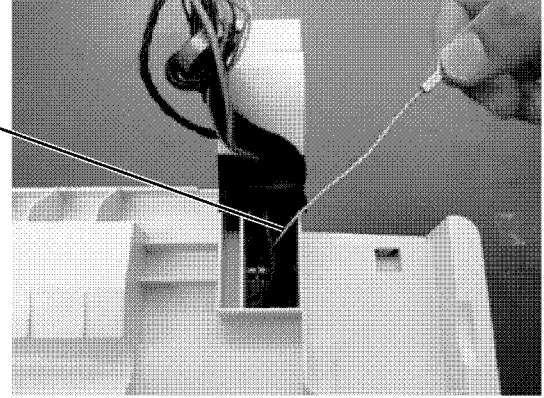

BOTTOM VIEW

The wire has come out from the left. If it assembles as it is, a wire will cut a lead.

NG

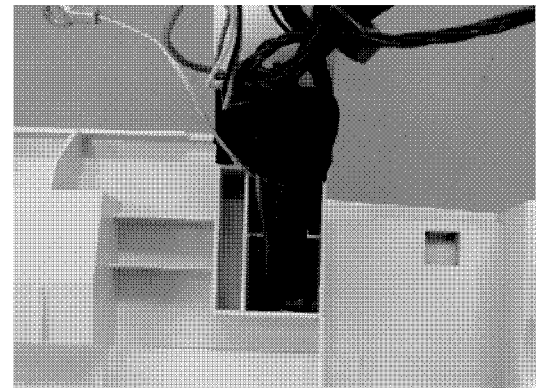

BOTTOM VIEW

OK

The wire is coming under the lead.

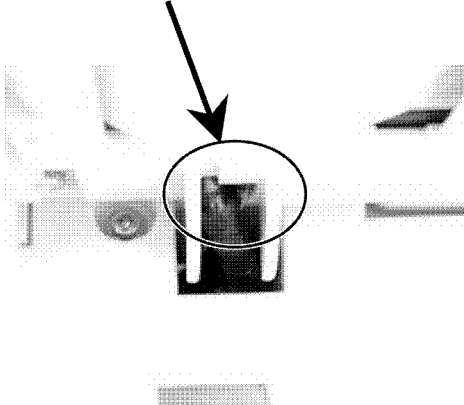

The wire is coming under the lead and the wire has come out from the right.

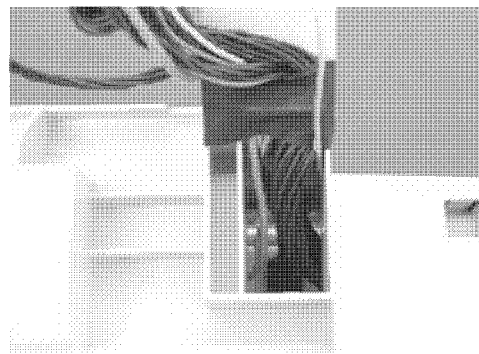

14.17.4. Bottom Part Section (1)

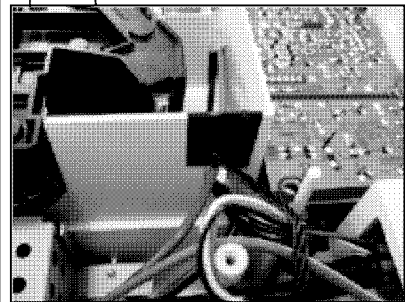
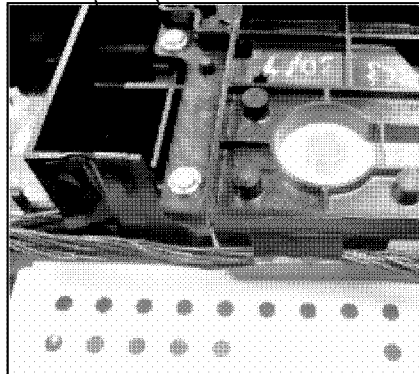
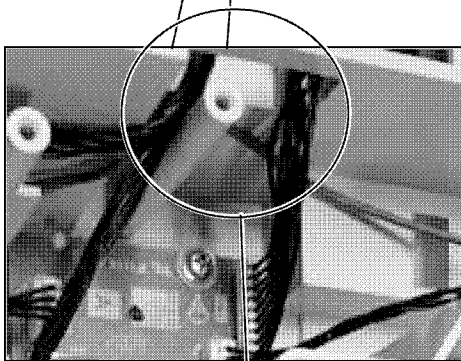
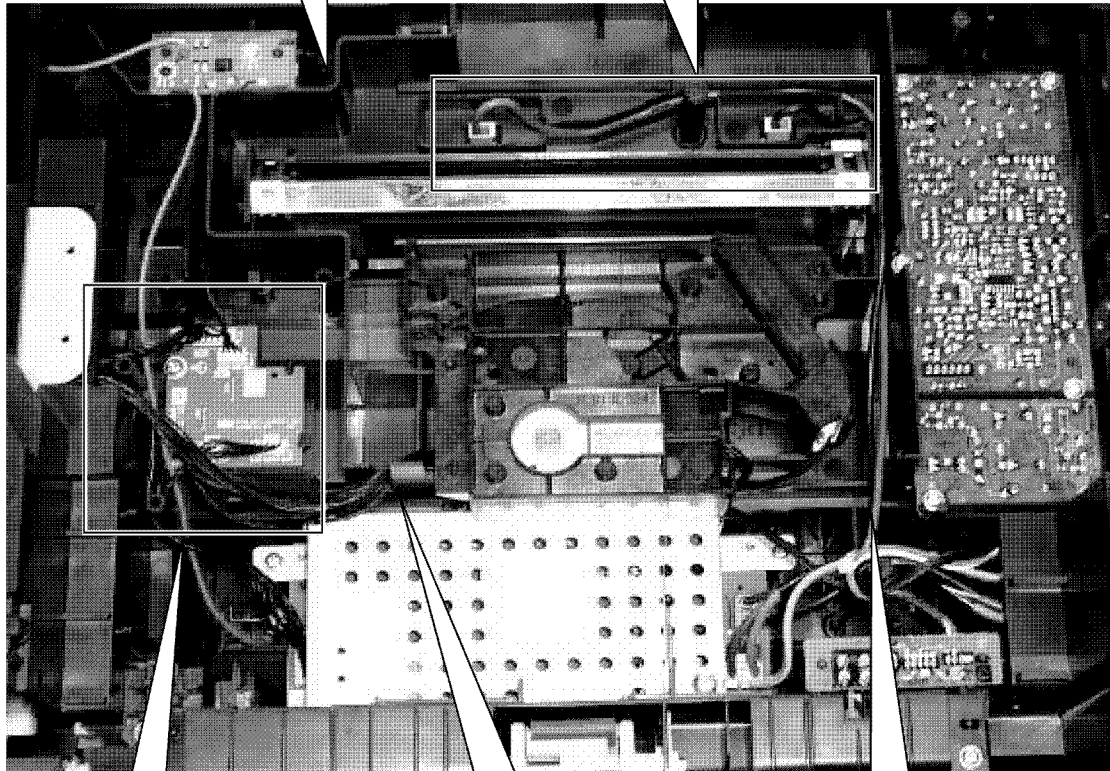
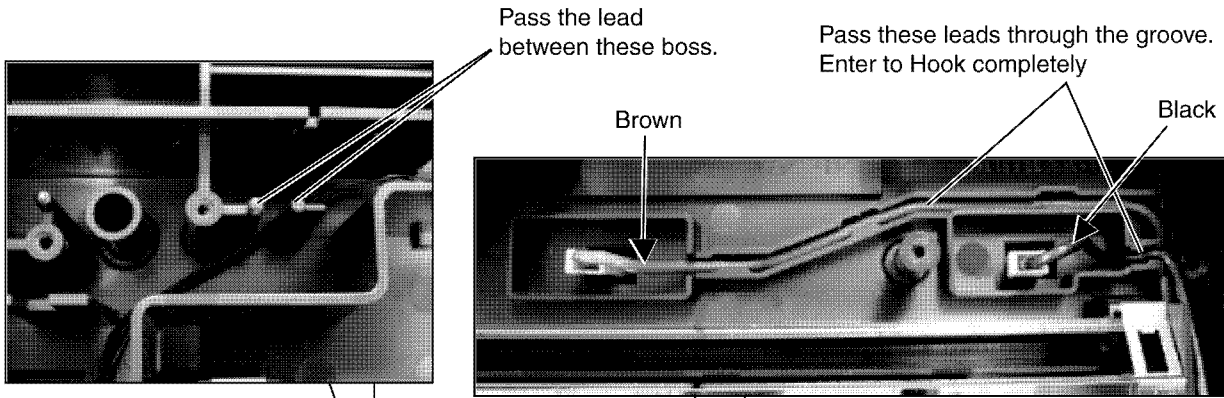

14.17.5. Bottom Part Section (2)

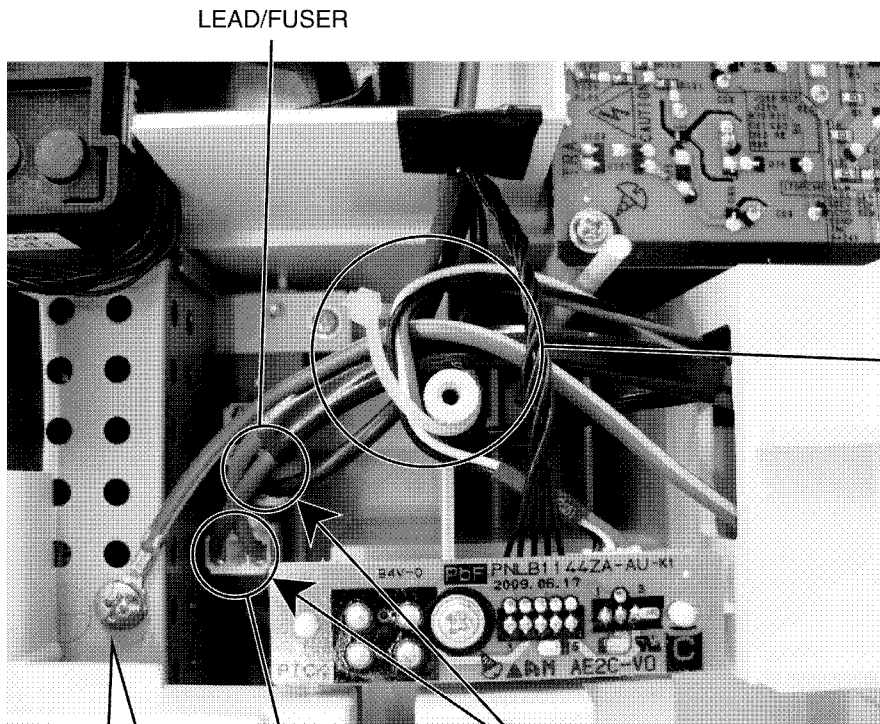

Bind for following leads around a boss with a binder.

- LEAD/AC EARTH
- HARNESS/AC
- LEAD/FUSER
- LEAD/HV

Don't insert LEAD/FUSER and HARNESS/AC by mistake.

HARNESS/AC

Dressing of LEAD/AC EARTH

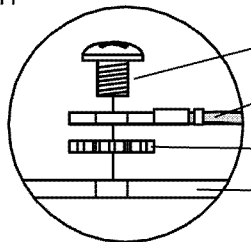
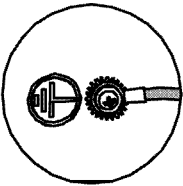

SCREW

Terminal of Harness

Washer

PLATE COVER SMPS

14.17.6. Side Cabinet Section (1)

Pass the EARTH LEAD through in this figure.

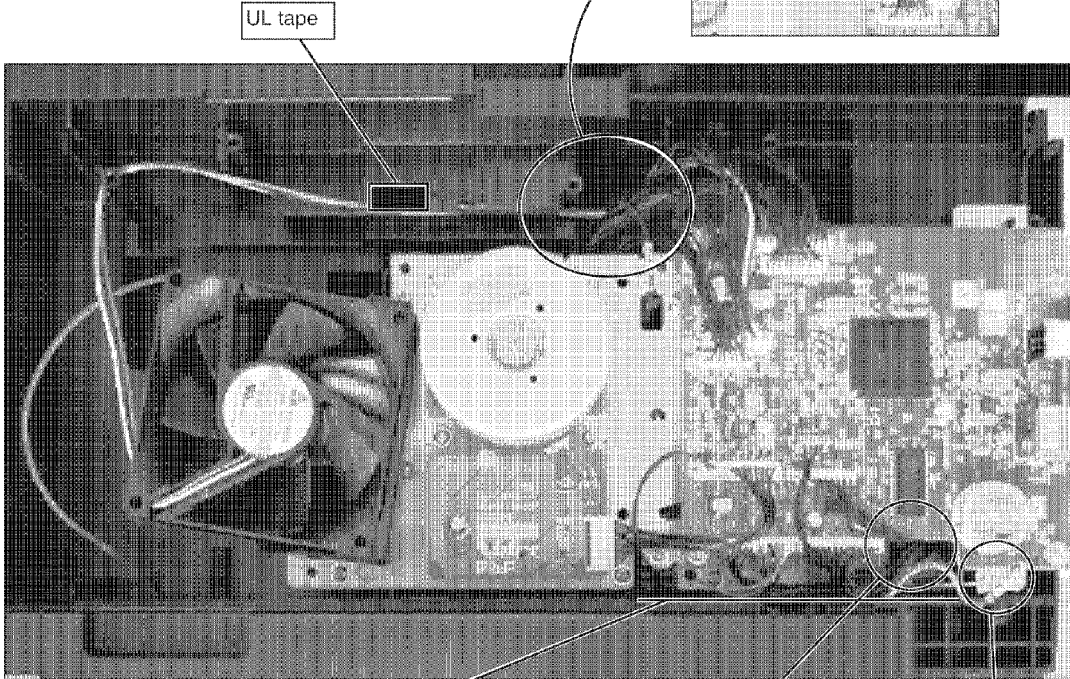
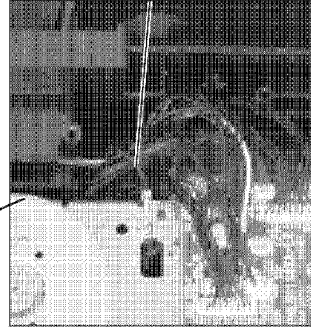

Harness must not come out below this line.

Cram the core into the opening.

Installation detail of ADF WIRE and EARTH LEAD

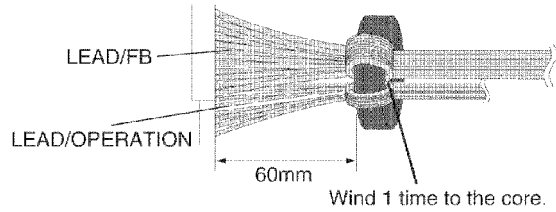
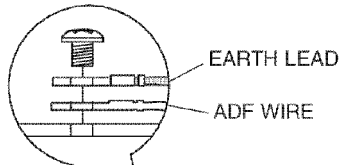

Don't overlap with riveted o wire

Terminal of wire

View A

Bend of plate

Tighten the earth lead together.
The earth leads must not be under UNIT BOARD MAIN.

14.17.7. Side Cabinet Section (2)

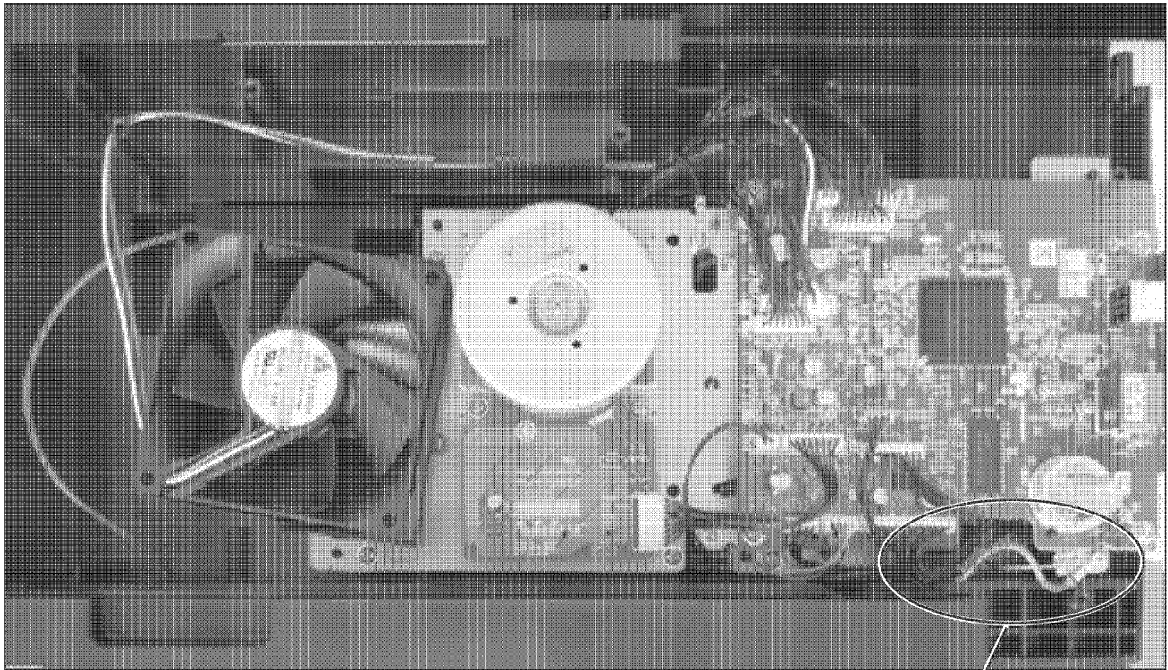

Details of the lead line processing of installation of FB/ASSY

Process the line so that the lead line should not come between Maincabi and the wire.

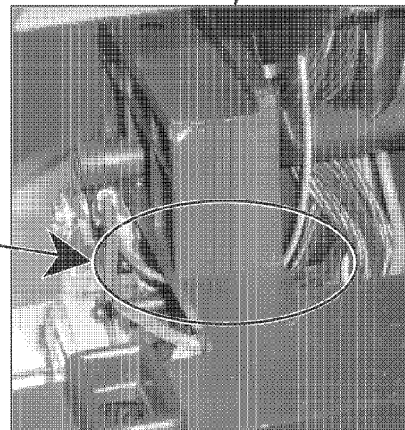

The lead is not coming between Maincabi and a wire. **OK**

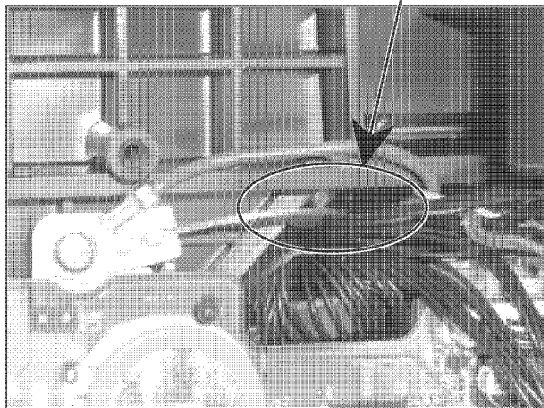

The lead is coming between Maincabi and a wire. **NG**

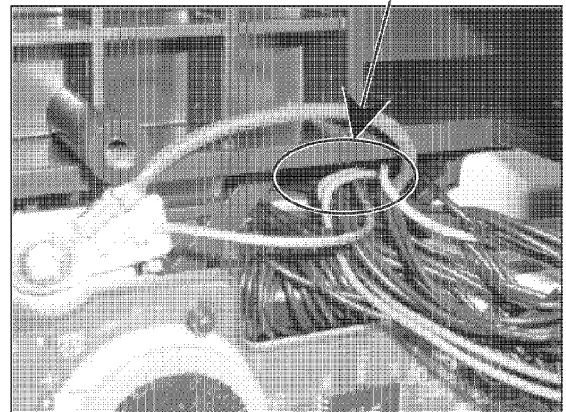

14.17.8. Side Cabinet Section (3)

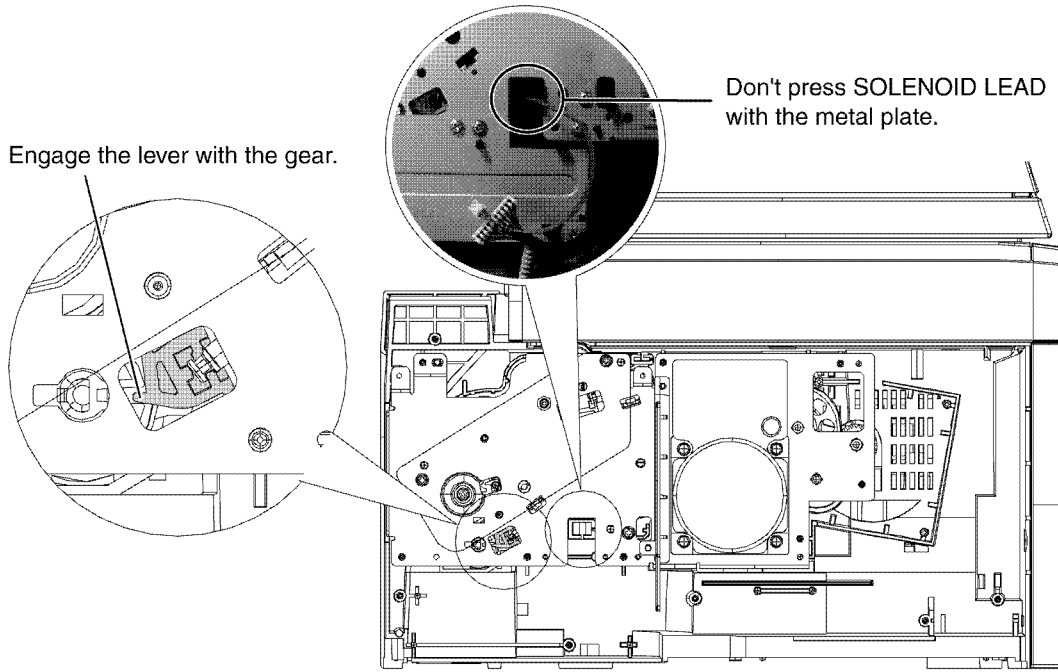

Install it in this direction.(label side)

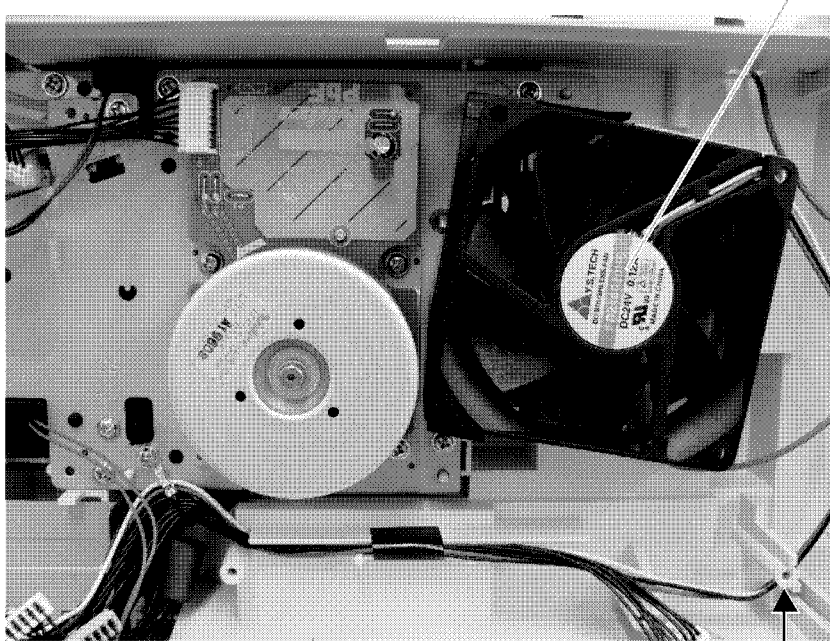

This boss outside is passed.

14.17.9. Side Cabinet Section (4)

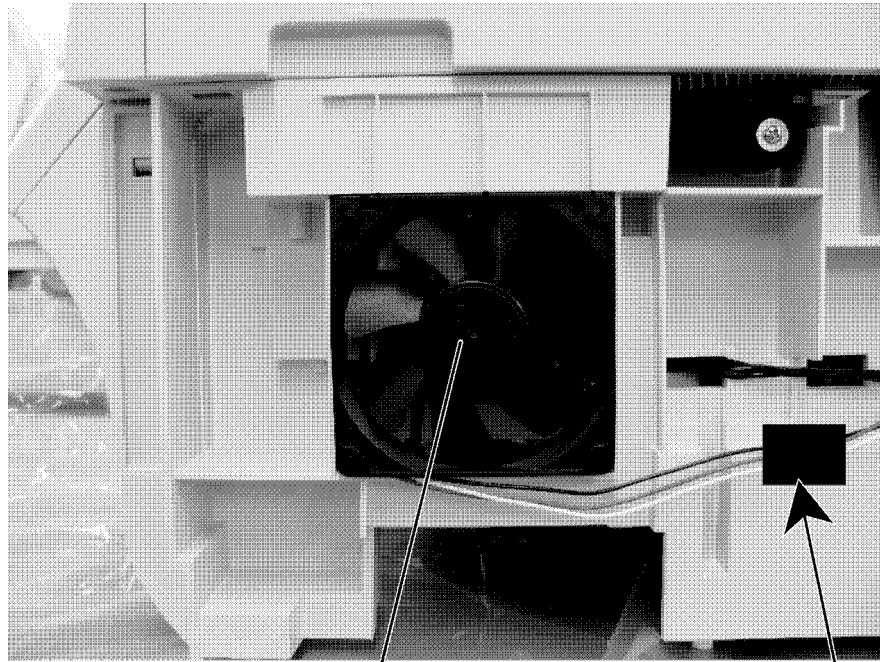

Install it in this direction.(no label side)

UL tape

14.17.10.AC Inlet Section

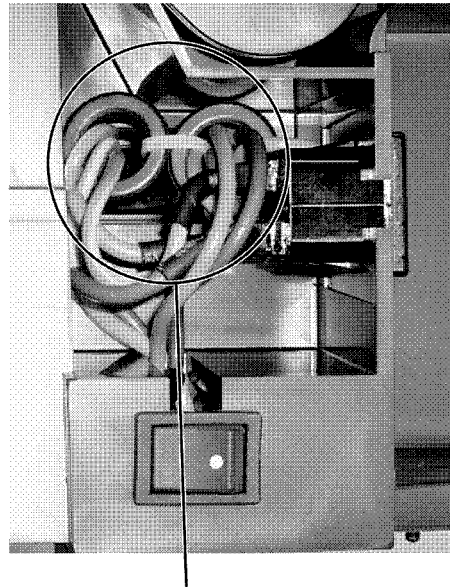

Insert the LEAD/AC EARTH core ,†astened by binder.

15 Maintenance

15.1. Maintenance Items and Component Locations

15.1.1. Outline

MAINTENANCE AND REPAIRS ARE PERFORMED USING THE FOLLOWING STEPS.

1. **Periodic maintenance**
Inspect the equipment periodically and if necessary, clean any contaminated parts.
2. **Check for breakdowns**
Look for problems and consider how they arose.
If the equipment can be still used, perform copying, self testing or communication testing.
3. **Check equipment**
Perform copying, self testing and communication testing to determine if the problem originates from the transmitter, receiver or the telephone line.
4. **Determine causes**
Determine the causes of the equipment problem by troubleshooting.
5. **Equipment repairs**
Repair or replace the defective parts and take appropriate measures at this stage to ensure that the problem will not recur.
6. **Confirm normal operation of the equipment**
After completing the repairs, conduct copying, self testing and communication testing to confirm that the equipment operates normally.
7. **Record keeping**
Make a record of the measures taken to rectify the problem for future reference.

15.1.2. Maintenance Check Items/Component Locations

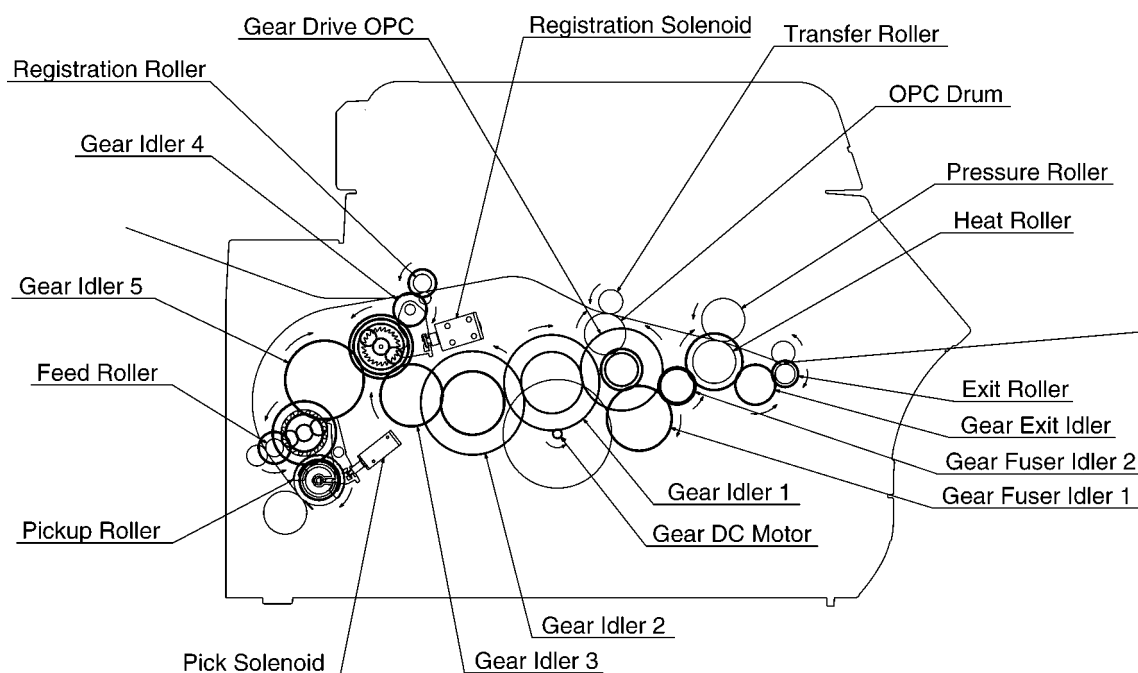

15.1.2.1. Maintenance List

NO.	OPERATION	CHECK	REMARKS
1	Document Path	Remove any foreign matter such as paper.	—
2	Rollers	If the roller is dirty, clean it with a damp cloth then dry thoroughly.	Refer to Maintenance Check Items/Component Locations (P.186)
3	Sensors	Document sensor (PS54) (KX-MB2010 ONLY), Read position sensor (PS53) (KX-MB2010 ONLY), registration sensor (PS51), Pickup sensor (SW50), Print timing sensor (PS52), Toner sensor (IC51), Top cover sensor (SW1), Exit sensor (PS50), confirm the operation of the sensors.	See Maintenance Check Items/Component Locations (P.186) and Sensors and Switches Section (P.40) Test Functions (P.80)
4	Glass	If the glass is dirty, clean them with a dry soft cloth.	Refer to Maintenance (P.188).
5	Abnormal, wear and tear or loose parts	Replace the part. Check if the screws are tight on all parts.	—

15.1.2.2. Maintenance Cycle (Document & Paper)

No.	Item	Cleaning Cycle
1	ADF Document Feed Roller (Ref.No.46) (KX-MB2010 ONLY)	3 months
2	ADF Separation Rubber (Ref. No.33) (KX-MB2010 ONLY)	3 months
3	ADF Eject Roller (Ref.No.56) (KX- MB2010 ONLY)	3 months
4	Pick up Roller (Ref No.320)	-----
5	Separation Roller (Ref. No.340)	-----
6	Feed Roller (Ref.No.211)	3 months
7	Transfer Roller (Ref.No.161)	-----
8	Registration Roller (Ref.No.196)	3 months
9	Heat Roller (Ref.No.232)	-----
10	Exit Roller (Ref.No.242)	3 months

If each part has got dirty, clean it with a damp cloth then dry thoroughly.

* These values are standard and may vary depending on usage conditions.

15.2. Maintenance

15.2.1. Cleaning the white plates and glass

Clean the white plates and glass when a black line, a white line or a dirty pattern appears on:

- your recording paper,
- the original document,
- the scanned data, or

Caution:

- Be careful when handling the drum and toner cartridge.
- Do not use paper products, such as paper towels or tissues for cleaning.

15.2.1.1. White plates and scanner glass

1. Open the document cover (1).

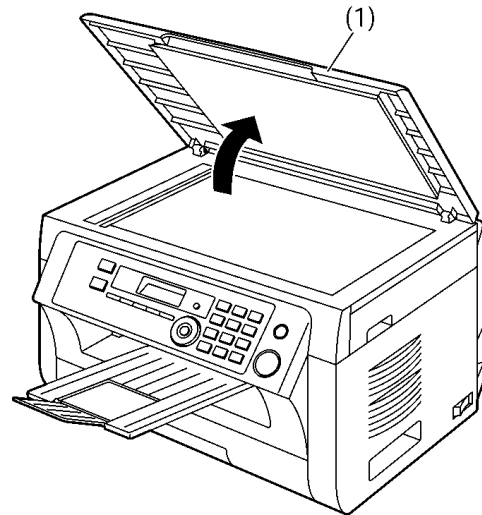

2. Hold the document cover while cleaning the white plates (2) and the scanner glass (3).

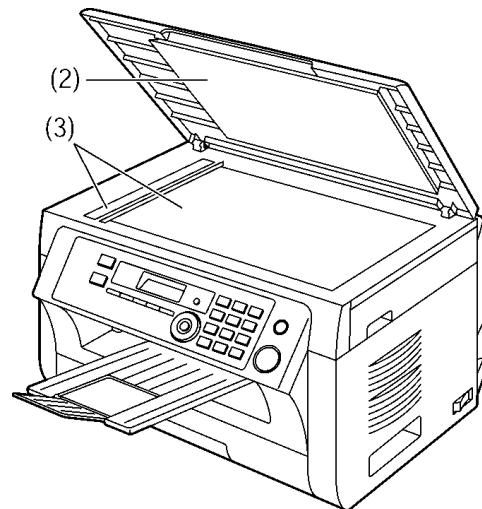

3. Close the document cover.

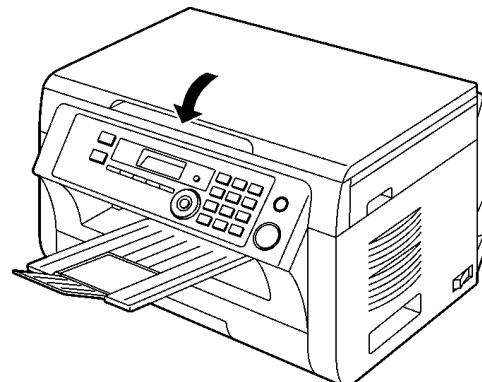

15.2.1.2. Lower glass

1. Turn the power switch OFF.
2. Open the top cover (1) by holding the indentations (2) on both sides of the unit.

Note:

- Do not touch the transfer roller (4).

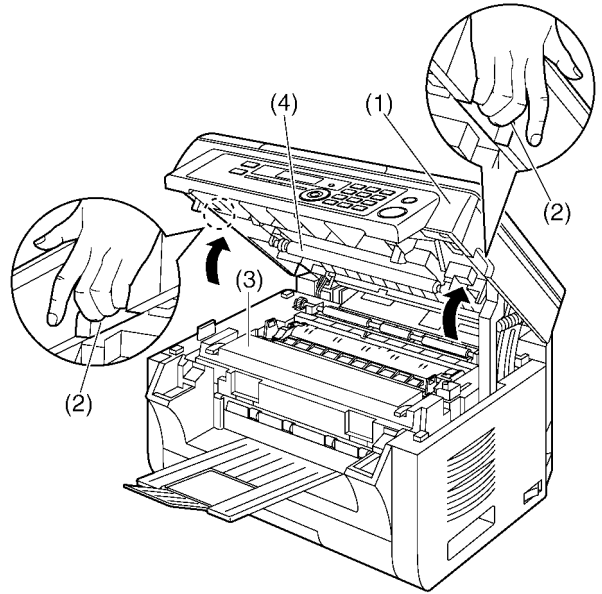

Caution:
The fuser unit (3) gets hot. Do not touch it.

3. Remove the drum and toner cartridge (5) by holding the tabs.

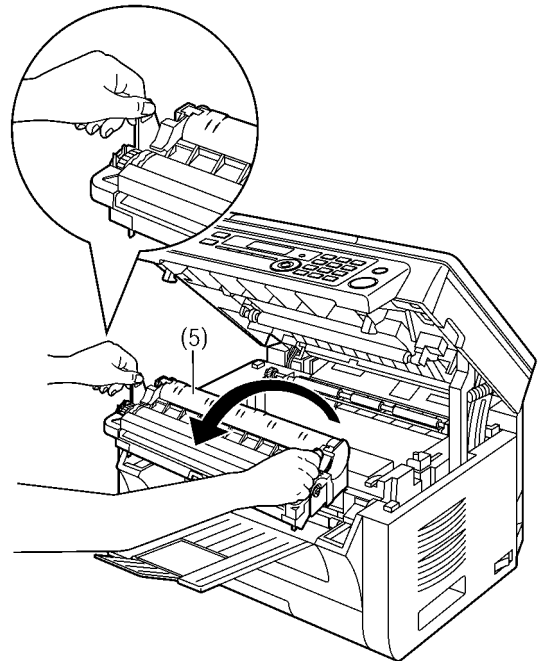

4. Clean the lower glass (6) with a soft and dry cloth.

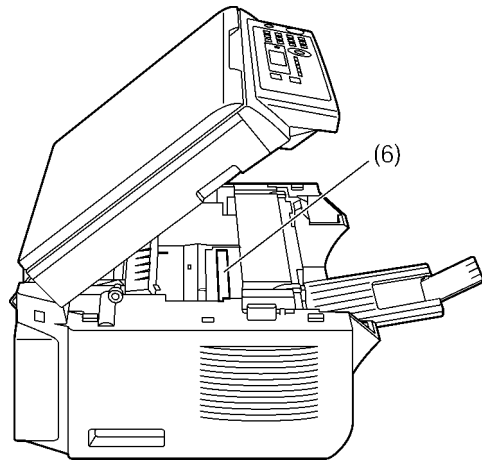

5. Reinstall the drum and toner cartridge (7) by holding the tabs.

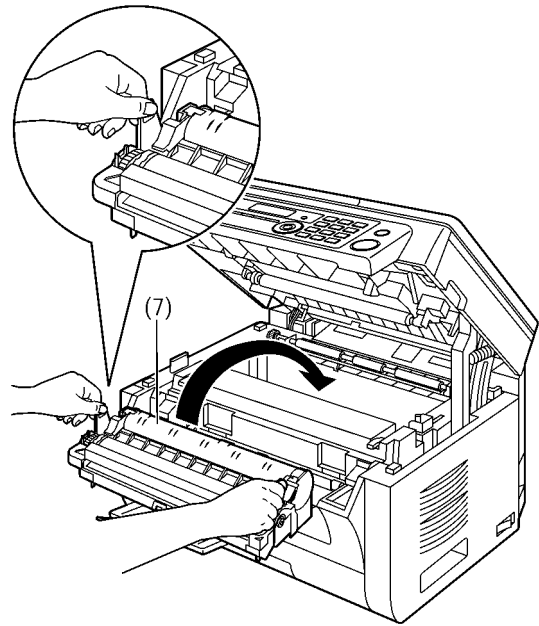

- Make sure that the arrows (8) match, to install the drum and toner cartridge correctly.

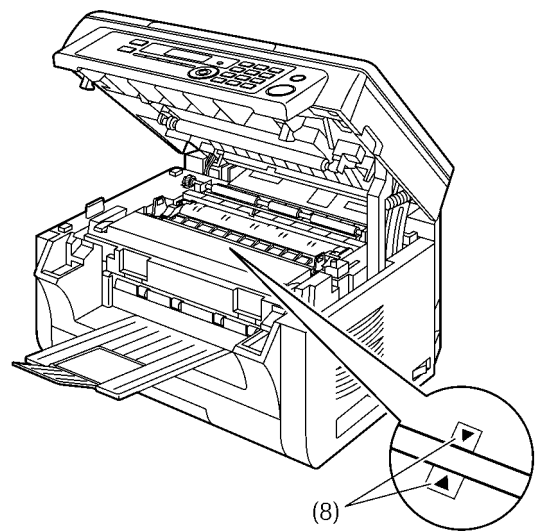

6. Close the top cover by holding the indentations on both sides of the unit, until locked.

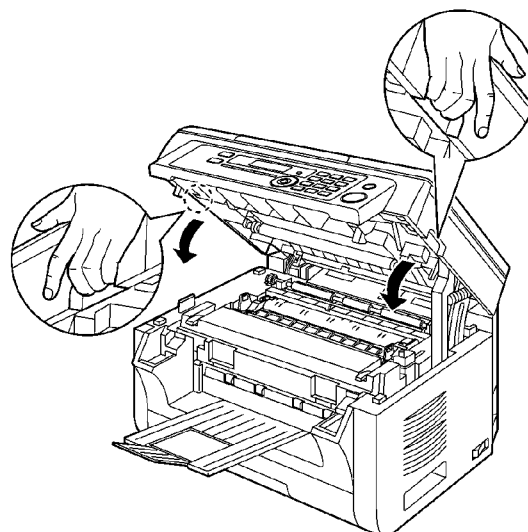

Caution:

- To prevent injuries, be careful not to put your hands under the top cover.

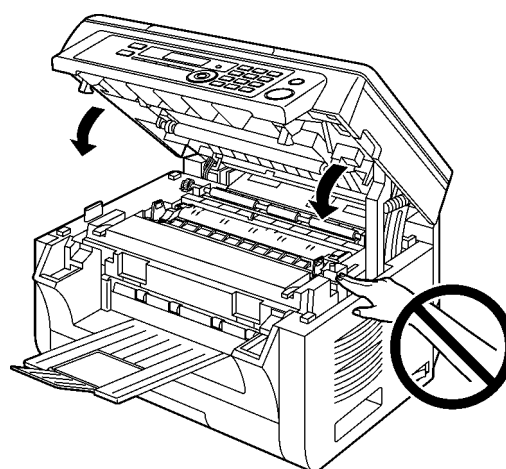

7. Turn the power switch ON.

15.2.2. CLEANING THE DOCUMENT FEEDER ROLLERS (KX-MB2010 ONLY)

Clean the rollers when documents frequently misfeed.

Caution:

- Do not use paper products, such as paper towels or tissues for cleaning.

1. Turn the power switch OFF.
2. Open the ADF cover (1) while holding the document cover (2).

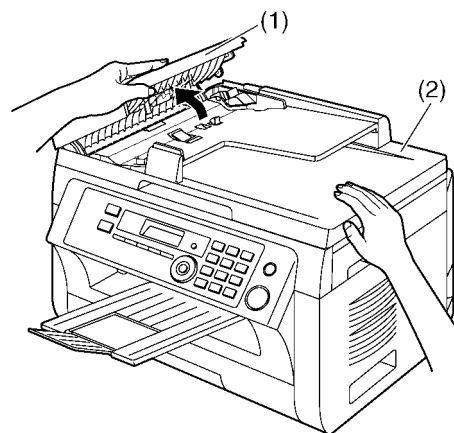

3. Clean the document feeder rollers (3) with a cloth moistened with water, and let all parts dry thoroughly.

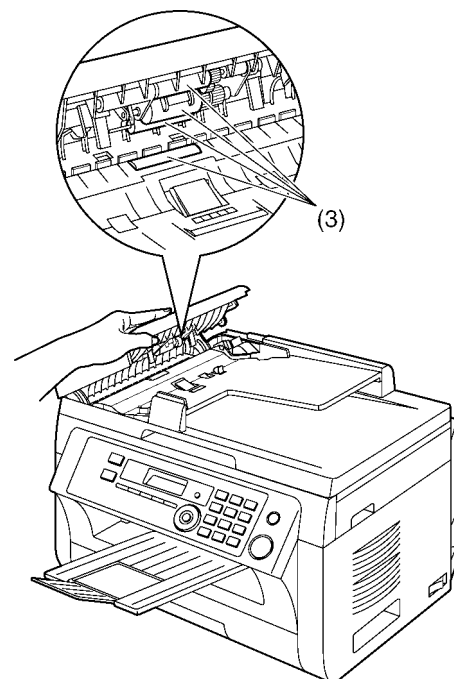

4. Close the ADF cover.

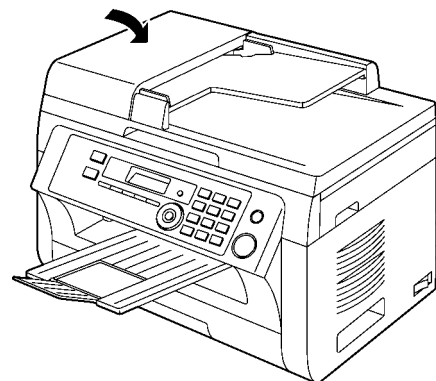

5. Turn the power switch ON.

15.3. Printing Operation Principle

15.3.1. Process Chart and Process BIAS

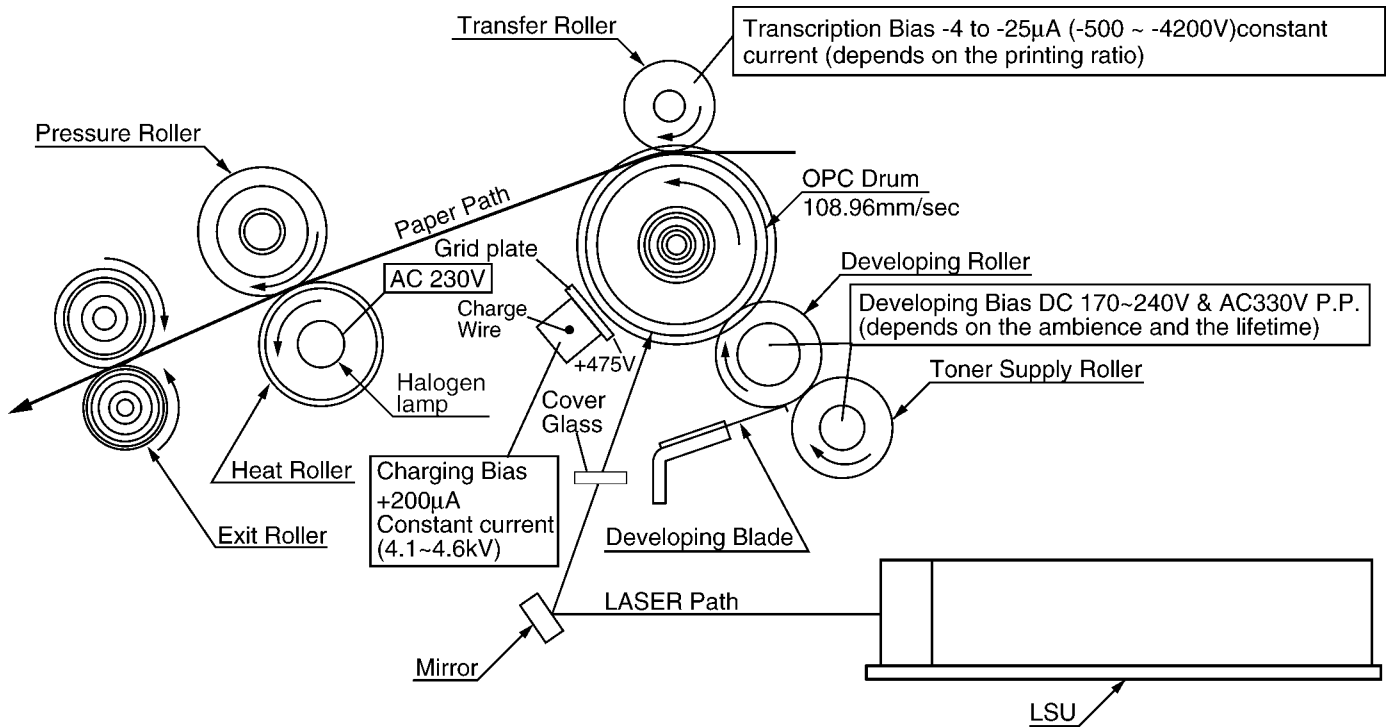

15.3.2. CHARGING

Charging is the stage that keeps the surface of the sensitive drum a fixed electric potential. The sensitive drum is the Organic Photo Conductor (OPC), which is a electric conductive cylinder whose surface is covered with the Charge Generation Transfer Layer (CGTL).

When the charging bias (DC +4.35kv) is added and the plus charge is supplied to the OPC surface while charging, the whole surface potential of the drum is +475V.

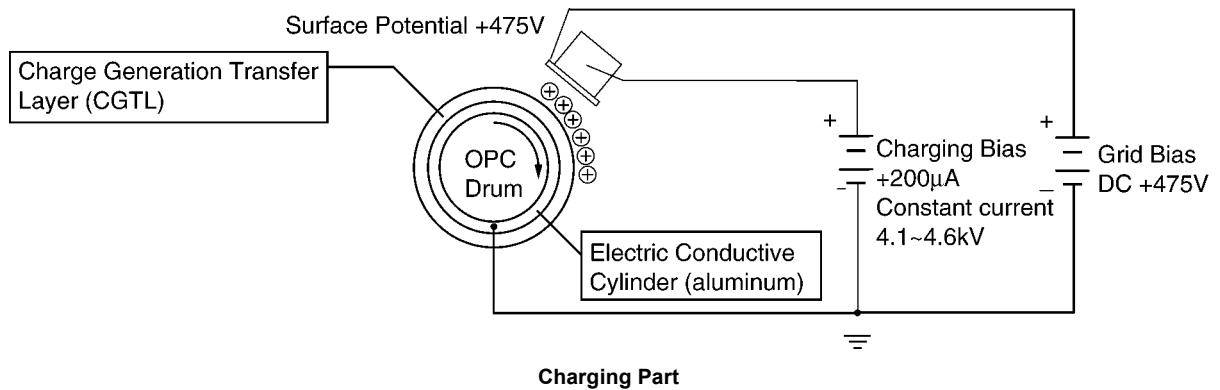

15.3.3. Exposing

When the drum which is charged with the fixed electric charge is irradiated by the laser beam, the plus charge and minus charge are generated at the Charge Generation Transfer Layer. Passing through the Charge Generation Transfer Layer which conducts the minus charge, the plus-charged drum's surface is neutralized to be skipped. Then the plus charge goes to the ground from the electric conductive cylinder. Consequently the charge of the part which is not exposed remains as it is, and the electric potential of the scanned part changes.

At that time an invisible image is created on the drum.

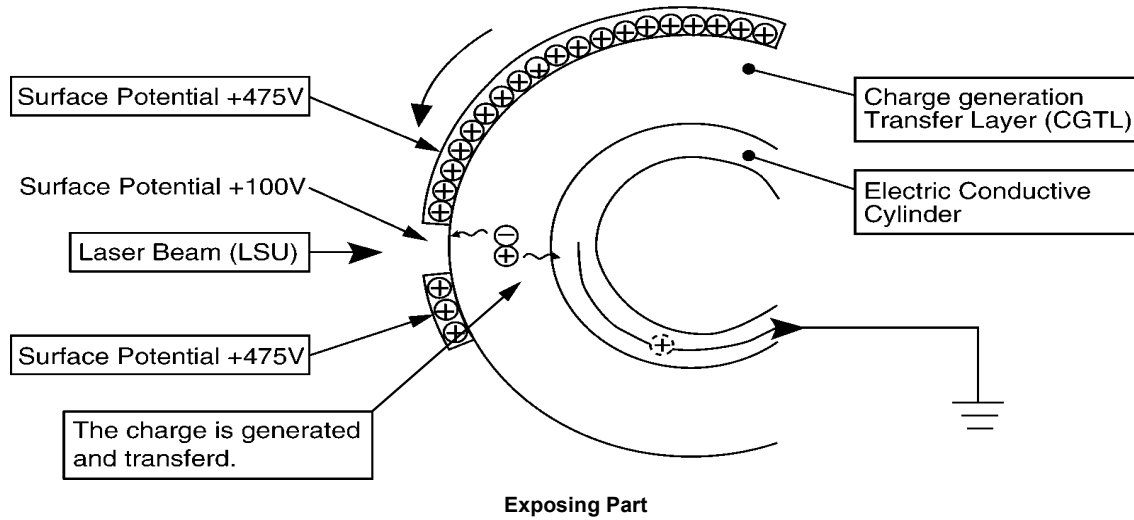

15.3.4. Developing and Transcription

The developing is the stage that the OPC drum with an invisible image is changed to visible by the toner. The drum cartridge consists of mixing paddle, toner supply roller, developing roller, developing blade, charge wire, grid plate and OPC drum. The bias voltage is added to the developing roller and toner supply roller. Firstly the toner is mixed up in the mixing paddle and plus-charged by triboelectricity, then led to the toner supply roller. Secondly the potential difference causes to send the toner to the developing roller from the toner supply roller. The supplied toner to the developing roller is kept to a certain layer thickness by the developing blade and also it is charged by triboelectricity. Consequently the toner is transferred to the surface of the exposed OPC drum by the potential difference between the developing roller and OPC drum's surface.

The transfer is the stage that the created image on the OPC drum is transferred to the paper. When the transfer roller is minus-charged with the image, the plus-charged toner particles are gathered on the surface of the drum and transferred to the paper.

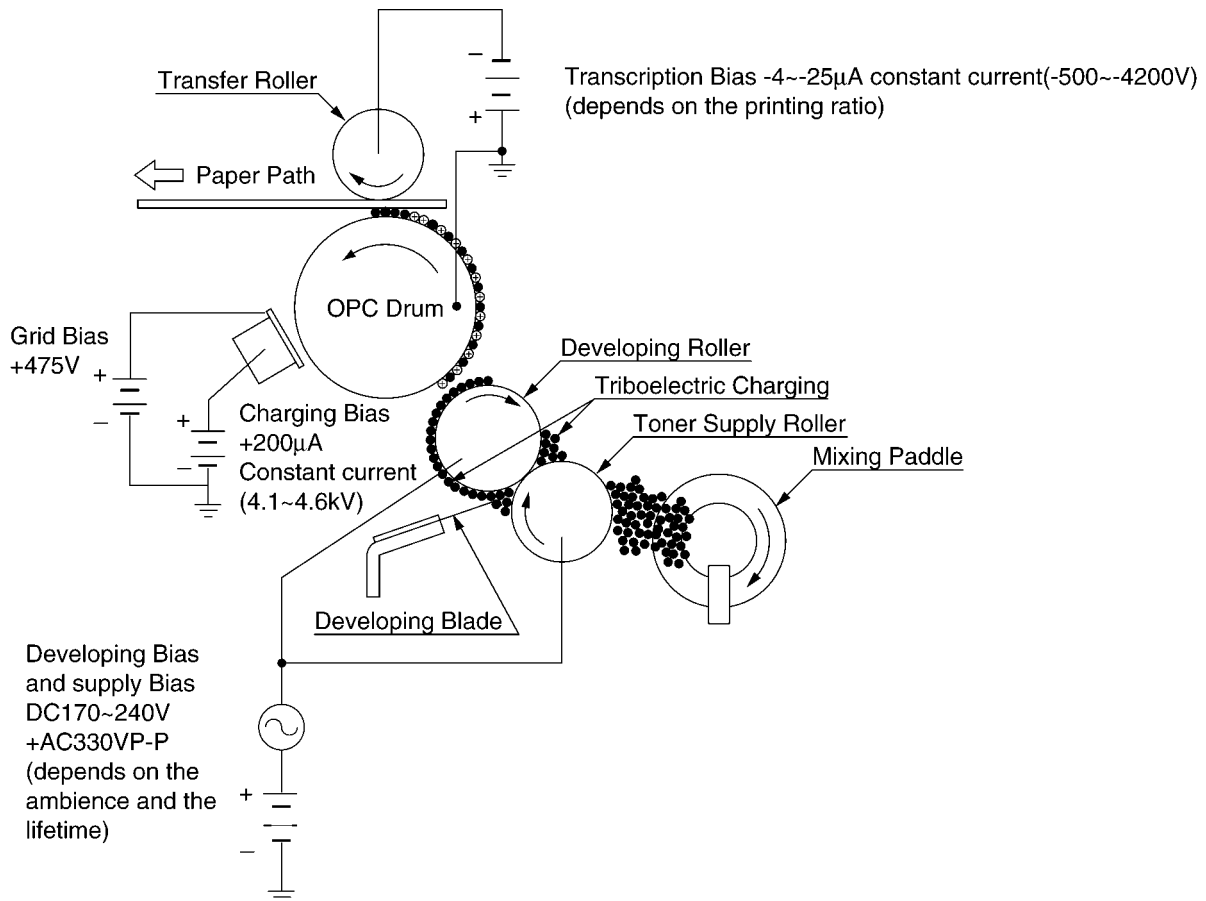

Developing and Transcription Part

15.3.5. Cleaning of Transfer Roller

The toner attached to the surface of the OPC drum is transferred to the paper at the transcription stage, but a part of the toner remains. The cleaning is the stage that cleans the remain toner after the transcription stage. The remain toner on the drum and the toner which was attached to the place where the laser beam didn't scan are gathered to the developing roller to be used again. After paper jam or replacing toner and drum cartridge, the transfer roller is plus-charged to eliminate the plus-charged toner.

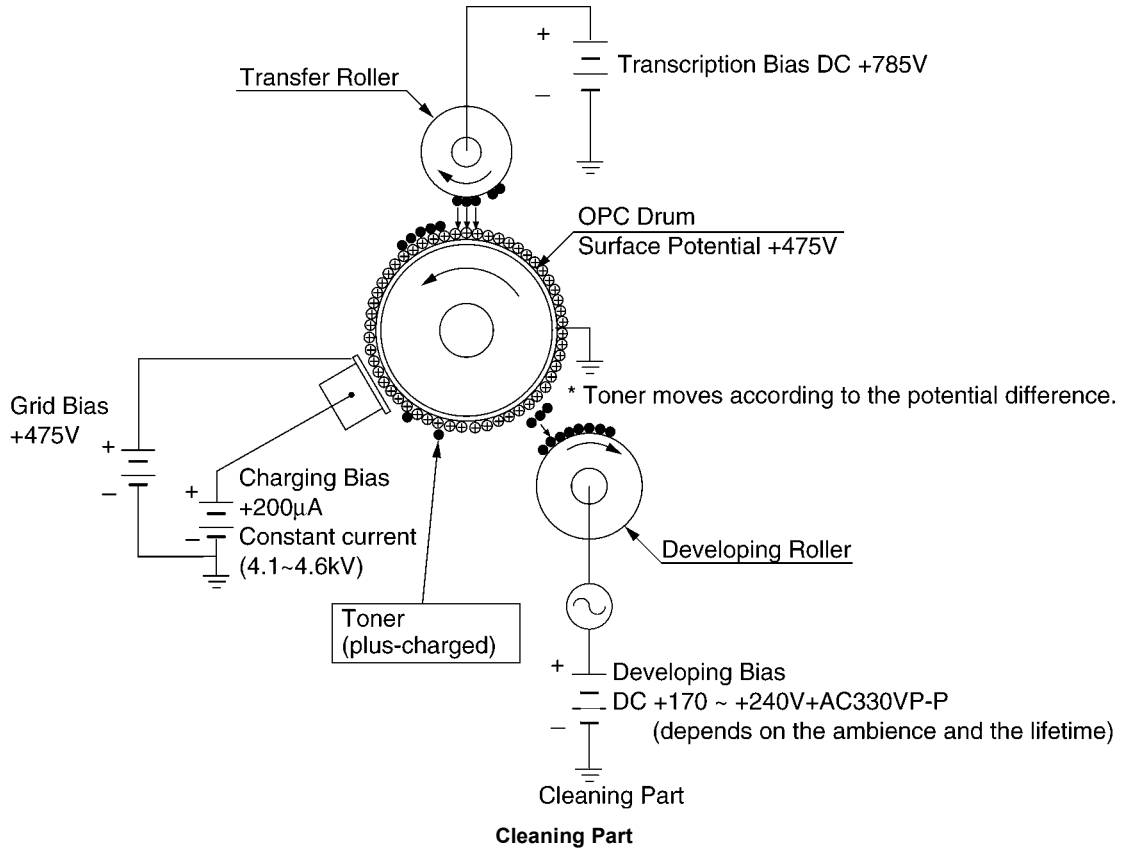

15.3.6. Fixing

On the process of the transfer, the transferred toner is weakly attached on the paper. Fixing means the process to fix the toner on the paper permanently. The fixing part melts the toner at the high temperature using the halogen heater. The toner is fixed on the paper by the heat and pressure through the fixing part with the image. The surface of the heat roller is rosined by Teflon and lubricated to prevent from attaching the toners. The press roller is made of silicon, and its spring compresses the melted toner.

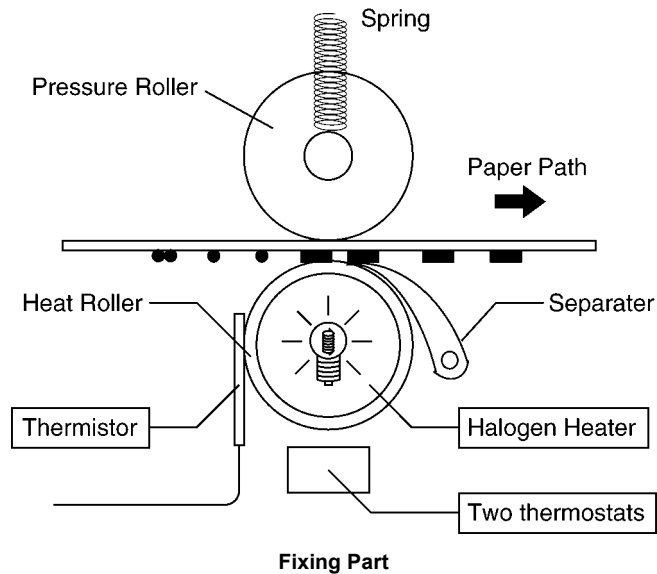

The fixing part becomes high temperature, so the thermistor and the two thermostats are provided.

1. Thermistor

The thermistor touches the heat roller and check the temperature to feed back to the control circuit. The surface temperature should be kept 195°C while printing.





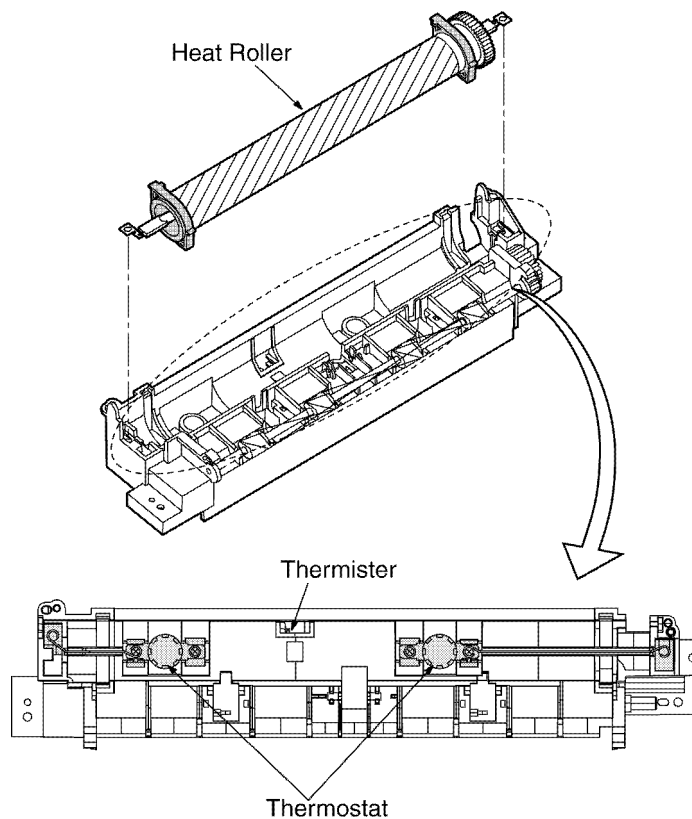





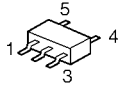
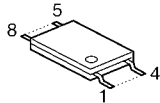
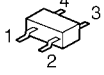
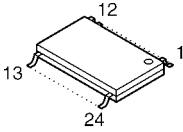
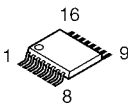
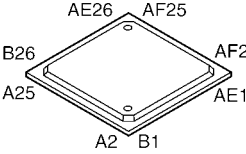
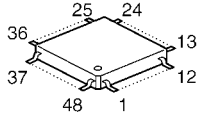
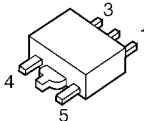
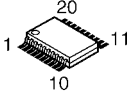
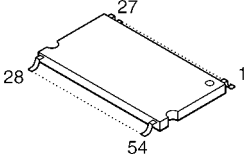
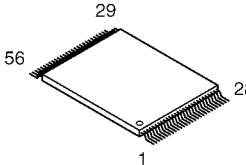
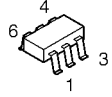
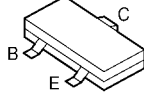

2. Thermostat

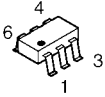
The thermostat is located near the heat roller, and it turns OFF the power when the temperature around the thermostat becomes over 160°C.



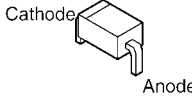

15.4. Terminal Guide of The ICs Transistors and Diodes

15.4.1. Main Board

 C0EBE0000504	 C0BBBA000044	 C0CBAAA00035	 C0GBY0000066	 C0DBAGE00028
 C1ZBZ0003801	 C1CB00002566	 C0DBGYY00330	 C1DB00001173	 C3ABRY000039
 PNWI****	 B1CHQD000001	 UN9219J B1ADGE000004 B1ADCF000161 B1ABCF000103	 2SD0874AS	 UNR92ANJ0L UNR921LJ0L UNR92A5J0L UNR92A9J0L
 B1CHND000004	 B0BC01000014	 B0ZBZ0000146	 B1ABKD000001 2SB1197KQ	 B3ABB0000331
 2SC4081R 2SK3018	 B0BC3R800009 B0JCPD000033	 MA142WKTX	 B0ACEL000004	 PJVDJADAN202

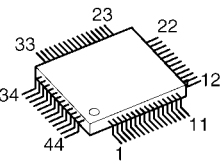

15.4.2. Operation Board

 C1ZBZ0004019	 B1ABGE000011			
---	---	--	--	--

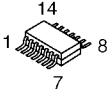
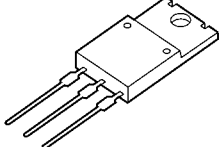
15.4.3. High Voltage Power Supply Board

 <p>PH1193AC001</p>	 <p>PT2394DL001</p>			
--	--	--	--	--

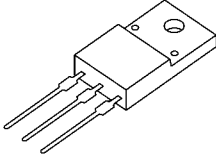
15.4.4. Low Voltage Power Supply Board

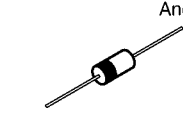
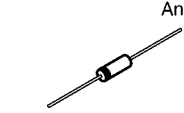
 <p>PT3565KL001</p>	 <p>PD1146AC001</p>	 <p>PD4145AA005</p>	 <p>PD4068AQ075</p>	
--	--	--	---	--

15.5. How to Replace the Flat Package IC

Even if you do not have the special tools (for example, a spot heater) to remove the Flat IC, with some solder (large amount), a soldering iron and a cutter knife, you can easily remove the ICs that have more than 100 pins.

15.5.1. Preparation

- PbF (: Pb free) Solder

- Soldering Iron

Tip Temperature of 700°F ± 20°F (370°C ± 10°C)

Note: We recommend a 30 to 40 Watt soldering iron. An expert may be able to use a 60 to 80 Watt iron where someone with less experience could overheat and damage the PCB foil.

- Flux

Recommended Flux: Specific Gravity → 0.82.

Type → RMA (lower residue, non-cleaning type)

Note: See **About Lead Free Solder (PbF: Pb free)** (P.7)

15.5.2. Flat Package IC Removal Procedure

1. Put plenty of solder on the IC pins so that the pins can be completely covered.

Note:

If the IC pins are not soldered enough, you may give pressure to the P.C. board when cutting the pins with a cutter.

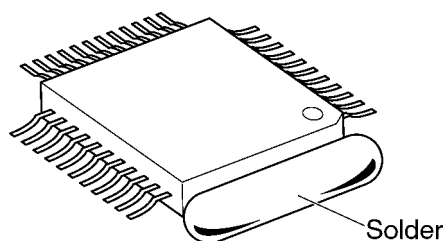

2. Make a few cuts into the joint (between the IC and its pins) first and then cut off the pins thoroughly.

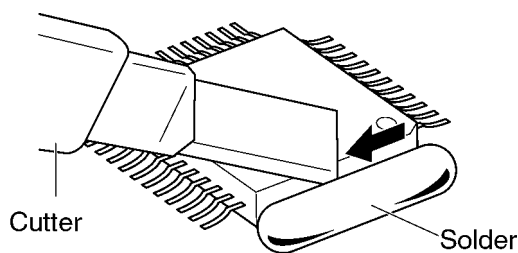

3. While the solder melts, remove it together with the IC pins.

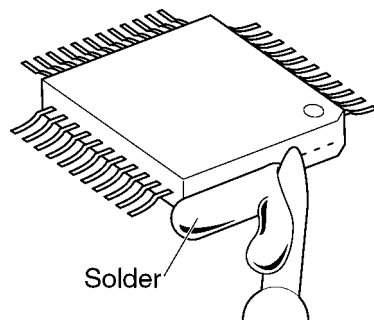

When you attach a new IC to the board, remove all solder left on the land with some tools like a soldering wire. If some solder is left at the joint on the board, the new IC will not be attached properly.

15.5.3. Flat Package IC Installation Procedure

1. Temporarily fix the FLAT PACKAGE IC, soldering the two marked pins.

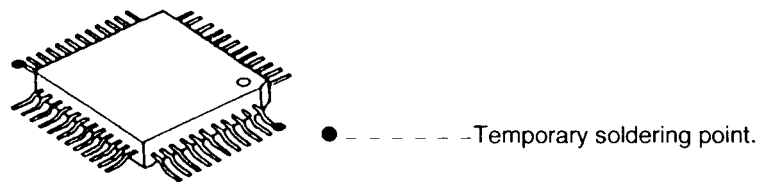

*Check the accuracy of the IC setting with the corresponding soldering foil.

2. Apply flux to all pins of the FLAT PACKAGE IC.

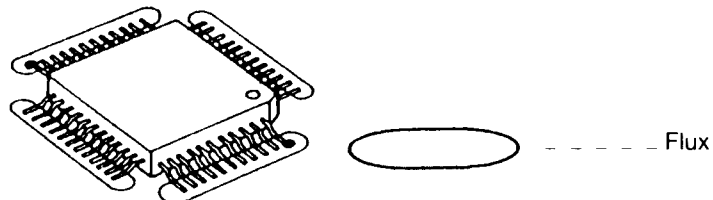

3. Solder the pins, sliding the soldering iron in the direction of the arrow.

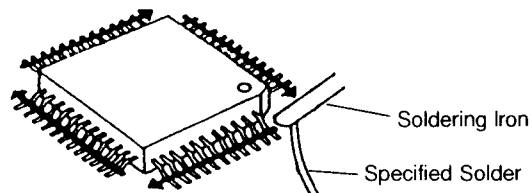

15.5.4. Bridge Modification Procedure

1. Lightly resolder the bridged portion.
2. Remove the remaining solder along the pins using a soldering iron as shown in the figure below.

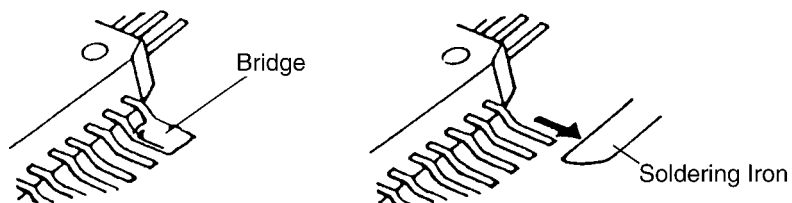

15.6. Main Board Section

When the unit fails to boot up the system, take the troubleshooting procedures very carefully. It may have a serious problem.

The symptom: No response when the power is turned on. (No LCD display, and keys are not accepted.)

The first step is to check the power source. If there is no problem with the power supply unit, the problem may lie in the digital unit (main board).

As there are many potential causes in this case (ASIC, DRAM, etc.), it may be difficult to specify what you should check first. If a mistake is made in the order of checks, a normal part may be determined faulty, wasting both time and money.

Although the tendency is to regard the problem as a serious one (IC malfunction, etc.), usually most cases are caused by solder faults (poor contact due to a tunnel in the solder, signal short circuit due to solder waste).

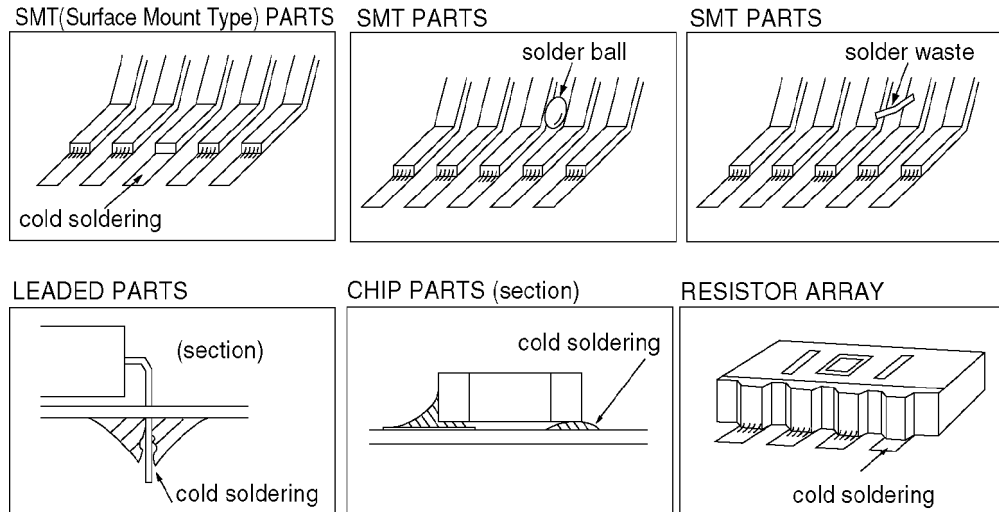

Note:

1. Electrical continuity may have existed at the factory check, but a faulty contact occurred as a result of vibration, etc., during transport.

2. Solder waste remaining on the board may get caught under the IC during transport, causing a short circuit.

Before we begin mass production, several hundred trial units are produced at the plant, various tests are applied and any malfunctions are analyzed. (In past experiences, digital IC (especially, DRAM and ROM) malfunctions are extremely rare after installation in the product.)

This may be repaired by replacing the IC, (DRAM etc.). However, the real cause may not have been an IC malfunction but a soldering fault instead.

Soldering faults difficult to detect with the naked eye are common, particularly for ASIC and RA (Resistor Array). But if you have an oscilloscope, you can easily determine the problem site or IC malfunction by checking the main signal lines.

Even if you don't have such a measuring instrument, by checking each main signal line and resoldering it, in many cases the problem will be resolved.

An explanation of the main signals (for booting up the unit) is presented below.

Don't replace ICs or stop repairing until checking the signal lines.

An IC malfunction rarely occurs. (By understanding the necessary signals for booting up the unit, the "Not Boot up" display is not a serious problem.)

What are the main signals for booting up the unit?

Please refer to **General Block Diagram** (P.14).

The ASIC (IC300) controls all the other digital ICs. When the power is turned on, the ASIC retrieves the operation code stored in the ROM (IC402), then follows the instructions for controlling each IC. All ICs have some inner registers that are assigned to a certain address.

It is the address bus by which the ASIC designates the location inside each IC. And the data bus reads or writes the data in order to transmit the instructions from the ASIC to the ICs.

These signal lines are all controlled by voltages of 3.3V (H) or 0V (L).

15.6.1. NG Example

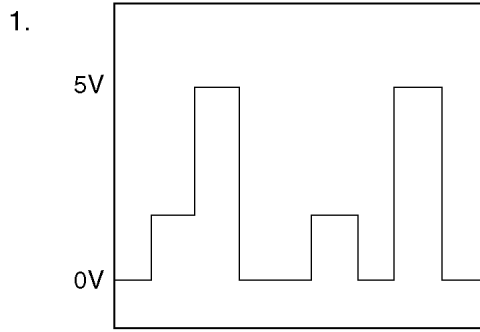

Short circuit from the adjacent signal wires.
Check for a short circuit in the RA and IC leads and the signal wire at the through hole.

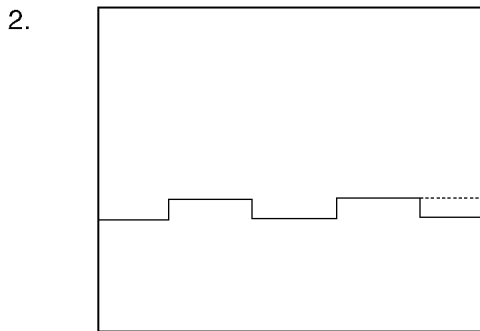
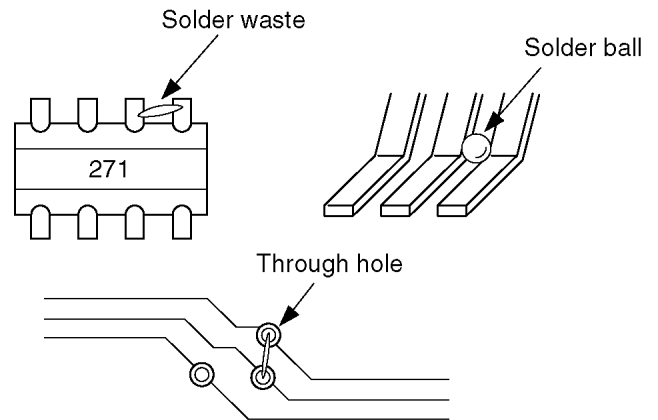

Short between the signal line and GND.

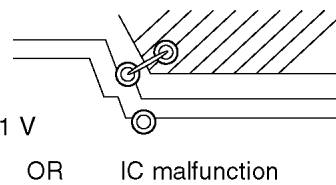

Approx. 0 or 1 V

OR IC malfunction

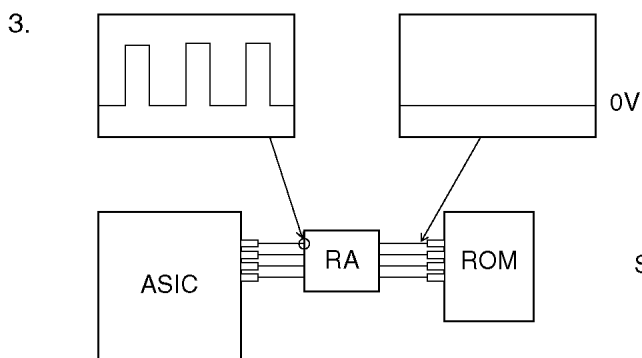
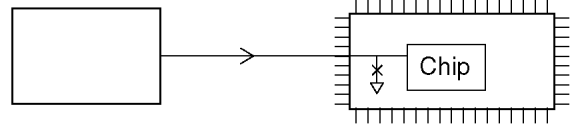

Solder fault on RA.

15.7. Test Chart

15.7.1. ITU-T No.1 Test Chart



THE SLEREXE COMPANY LIMITED

SAPORS LANE - BOOLE - DORSET - BH 25 8 ER

TELEPHONE BOOLE (945 13) 51617 - TELEX 123456

Our Ref. 350/PJC/EAC

18th January, 1972.

Dr. P.N. Cundall,
Mining Surveys Ltd.,
Holroyd Road,
Reading,
Berks.

Dear Pete,

Permit me to introduce you to the facility of facsimile transmission.

In facsimile a photocell is caused to perform a raster scan over the subject copy. The variations of print density on the document cause the photocell to generate an analogous electrical video signal. This signal is used to modulate a carrier, which is transmitted to a remote destination over a radio or cable communications link.

At the remote terminal, demodulation reconstructs the video signal, which is used to modulate the density of print produced by a printing device. This device is scanning in a raster scan synchronised with that at the transmitting terminal. As a result, a facsimile copy of the subject document is produced.

Probably you have uses for this facility in your organisation.

Yours sincerely,

Phil.

P.J. CROSS
Group Leader - Facsimile Research

15.7.2. ITU-T No.2 Test Chart

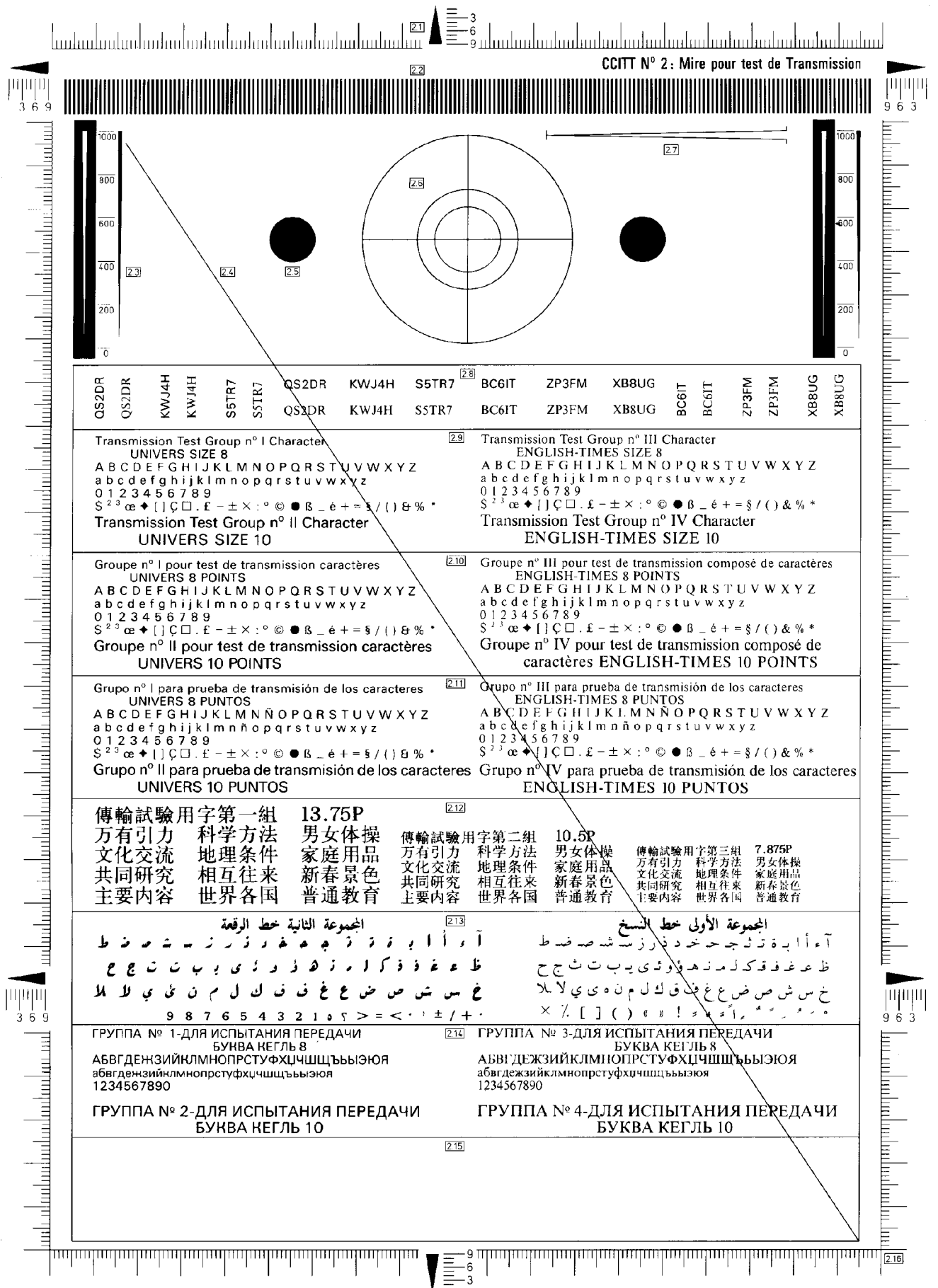

Memo

16 Schematic Diagram

16.1. For Schematic Diagram

Note:

1. DC voltage measurements are taken with an oscilloscope or a tester with a ground.
2. The schematic diagrams and circuit board may be modified at any time with the development of new technology.

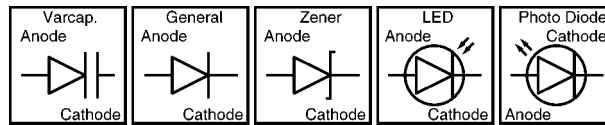

Important safety notice

Components identified by \triangle mark have special characteristics important for safety. When replacing any of these components, use only the manufacturer's specified parts.

16.2. Main Board (KX-MB2000)

16.2.1. Main Board (1)

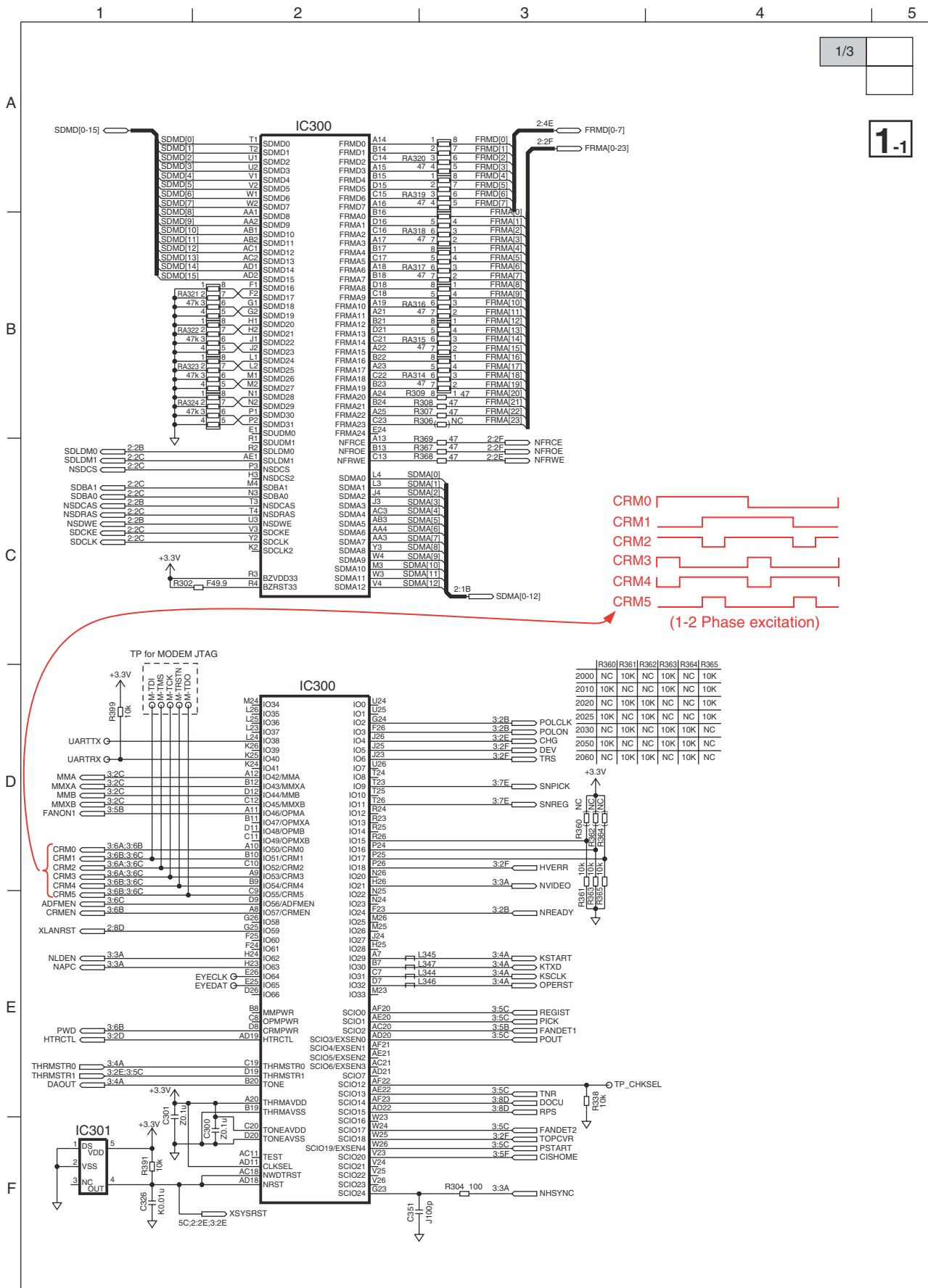

KX-MB2000HXB SCHEMATIC DIAGRAM (MAIN BOARD No.1) (1/3)

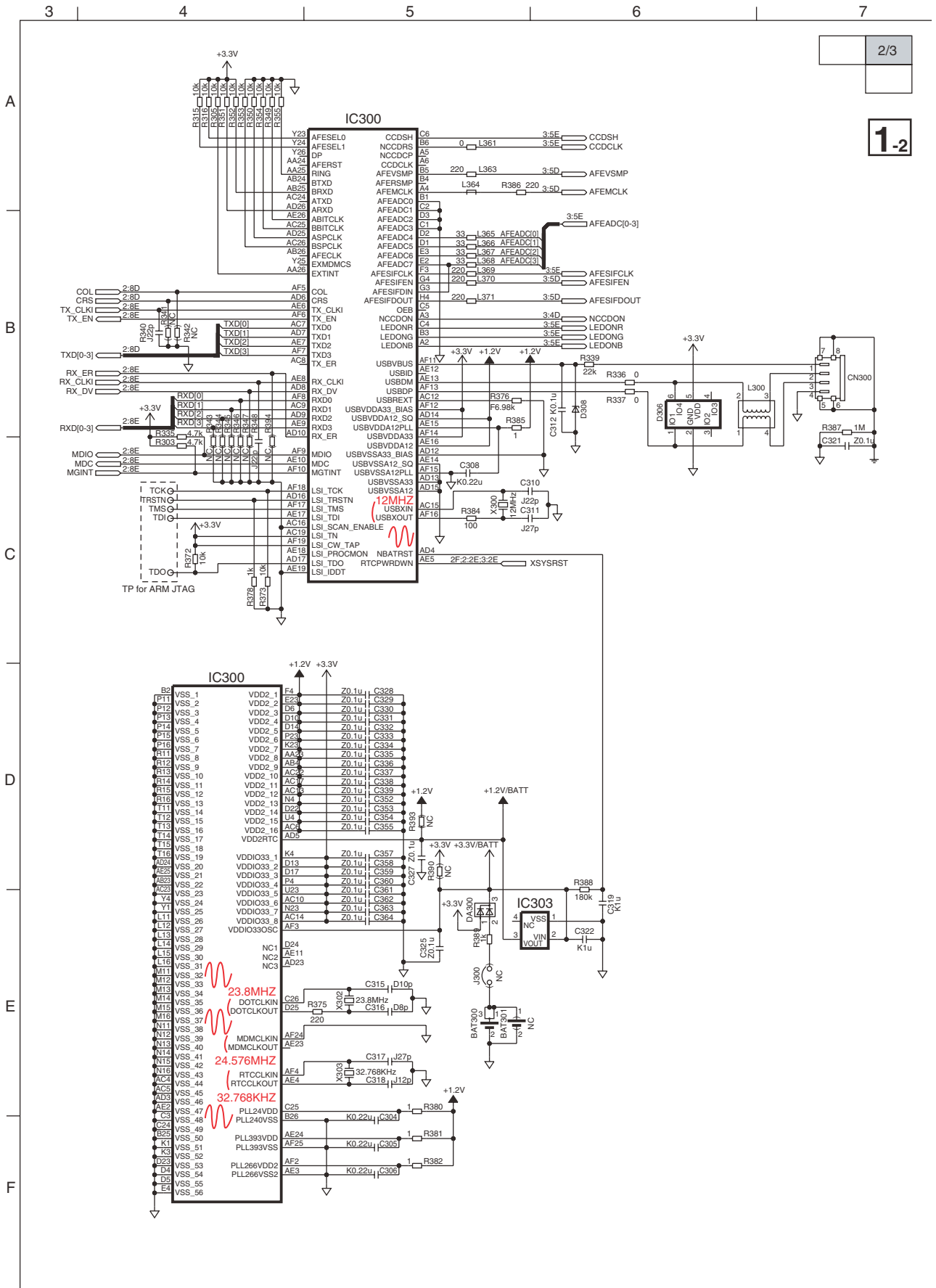

KX-MB2000HXB SCHEMATIC DIAGRAM (MAIN BOARD No.1) (2/3)

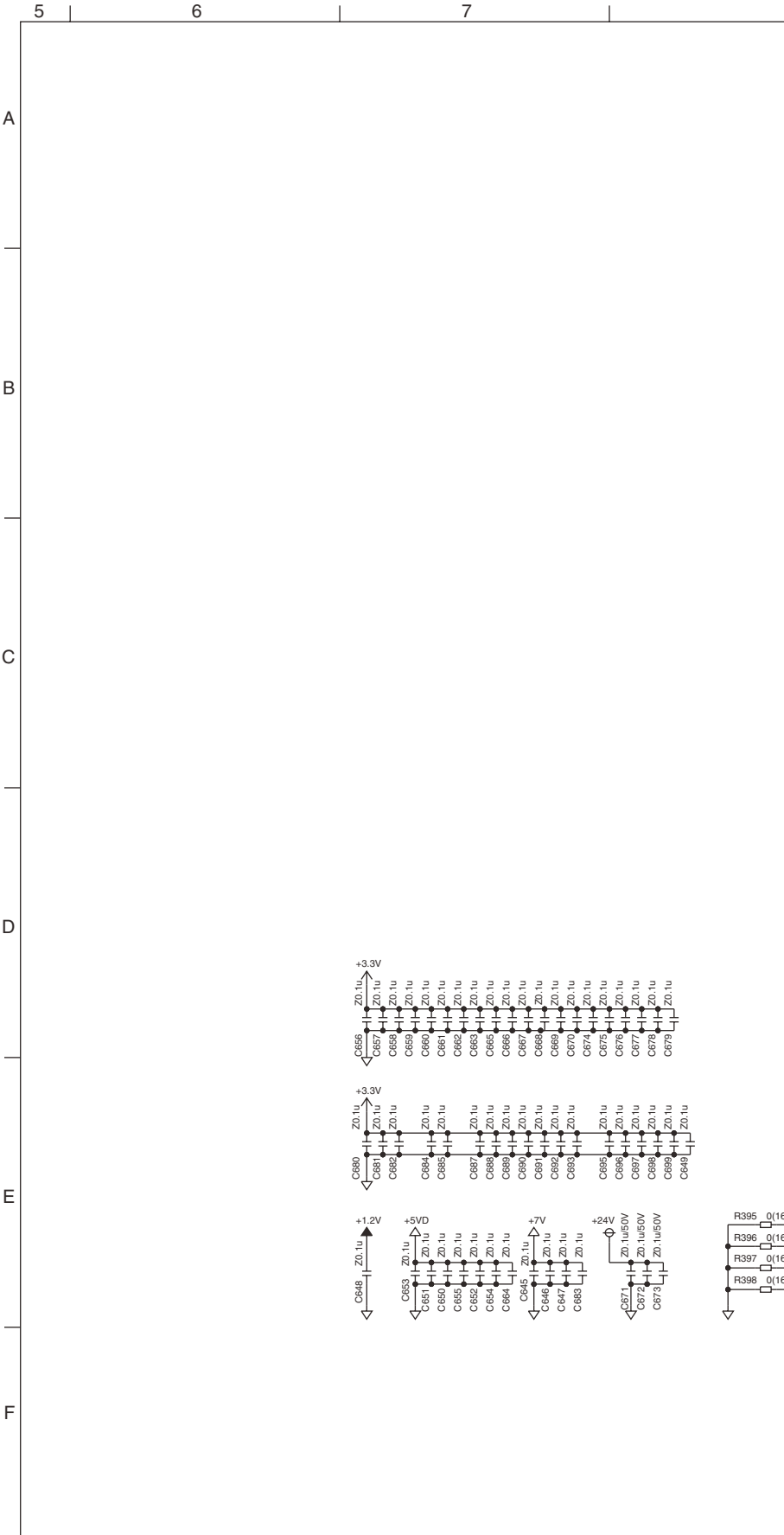

3/3

1-3

KX-MB2000HXB SCHEMATIC DIAGRAM (MAIN BOARD No.1) (3/3)

Memo

16.2.2. Main Board (2)

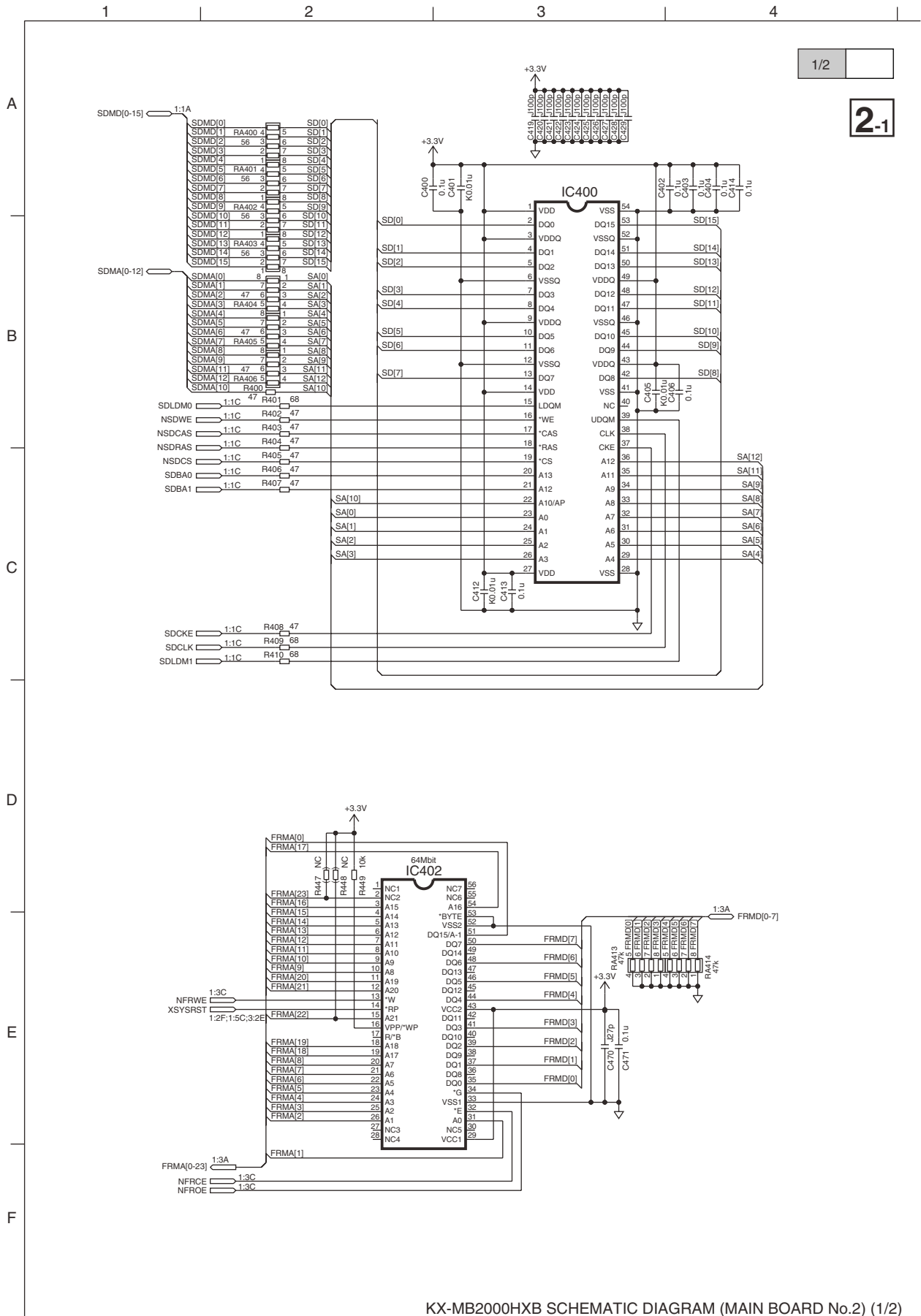

KX-MB2000HXB SCHEMATIC DIAGRAM (MAIN BOARD No.2) (1/2)

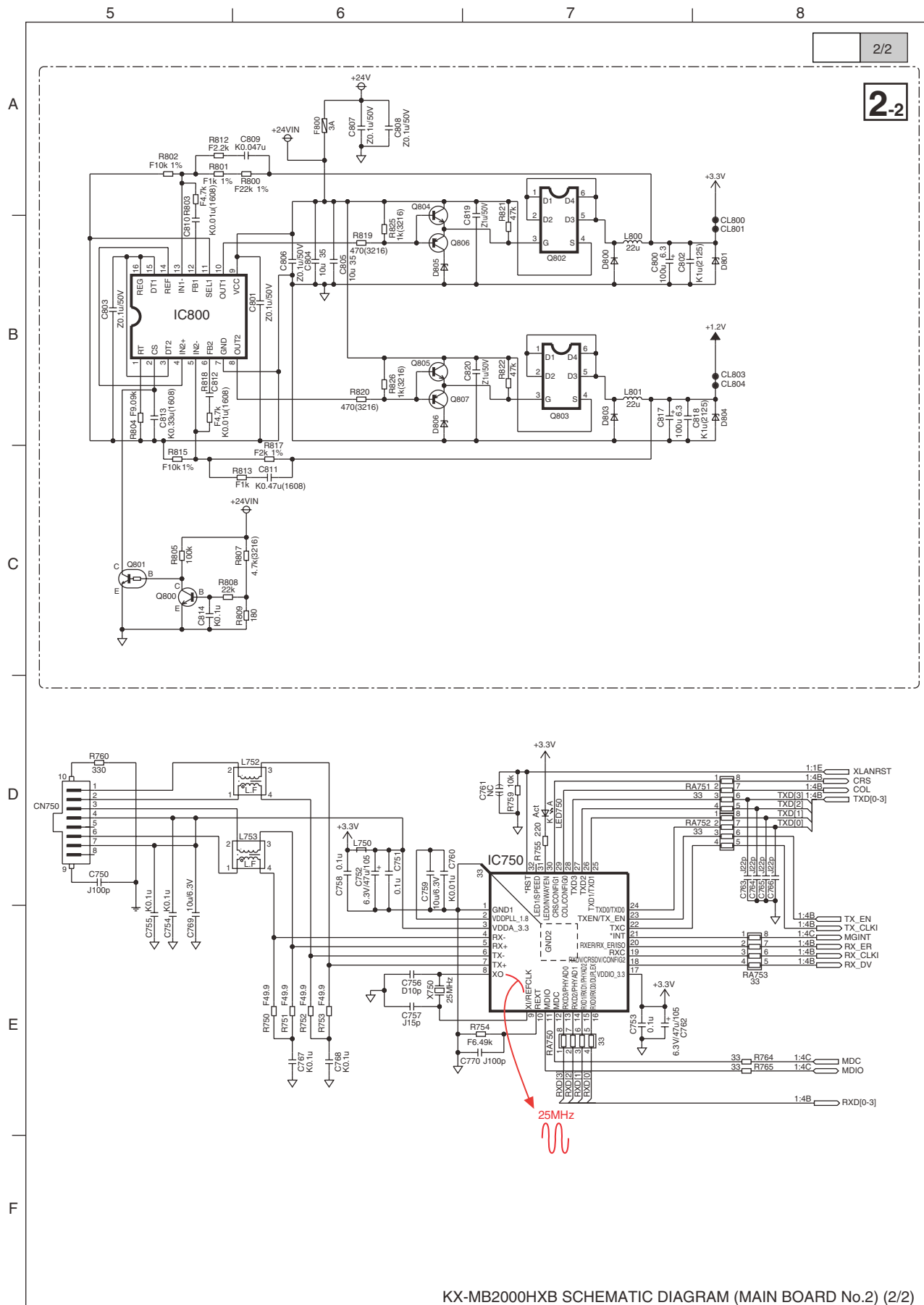

KX-MB2000HXB SCHEMATIC DIAGRAM (MAIN BOARD No.2) (2/2)

16.2.3. Main Board (3)

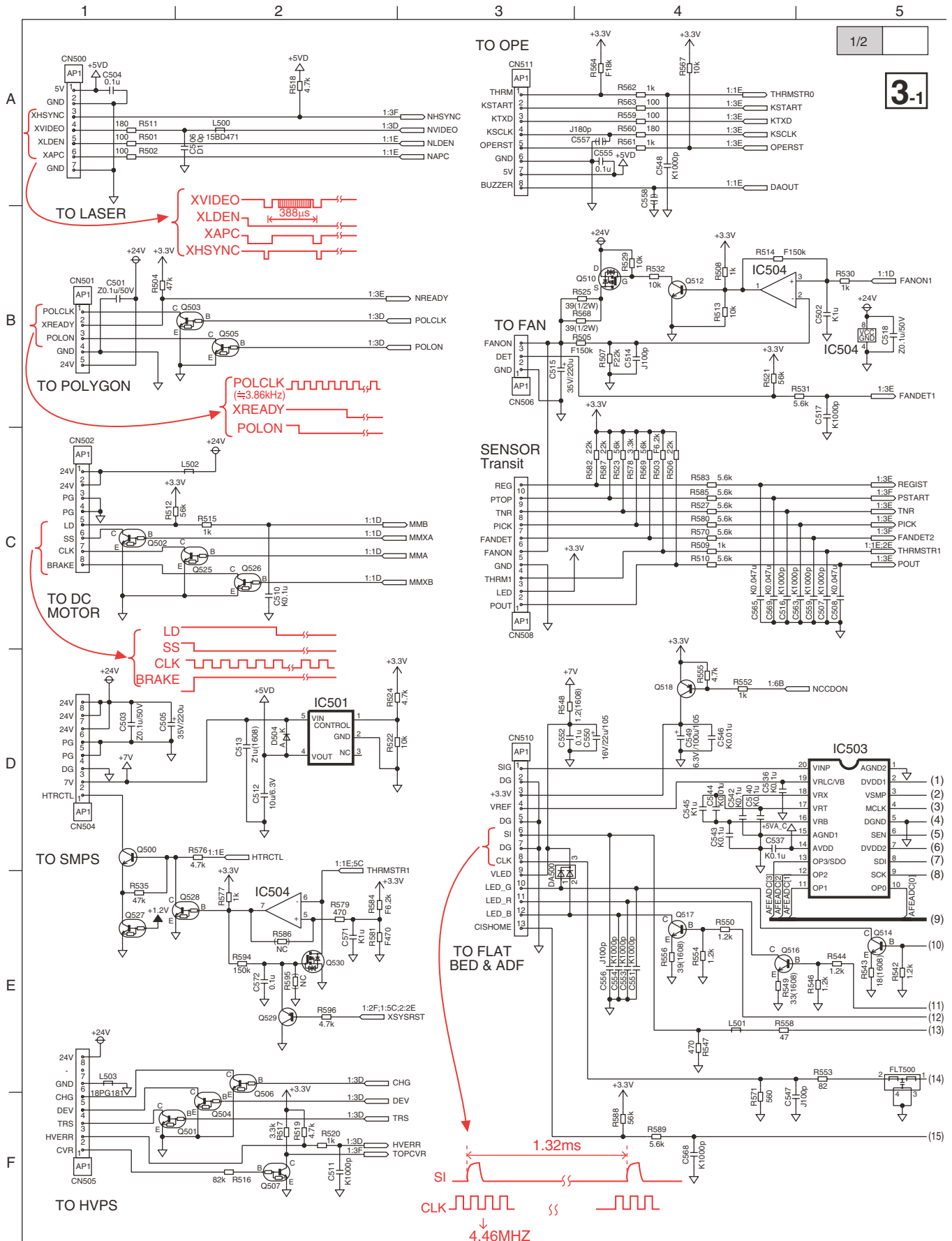

KX-MB2000HXB SCHEMATIC DIAGRAM (MAIN BOARD No.3) (1/2)

5

6

7

8

9

2/2

3-2

A
B
C
D
E
F

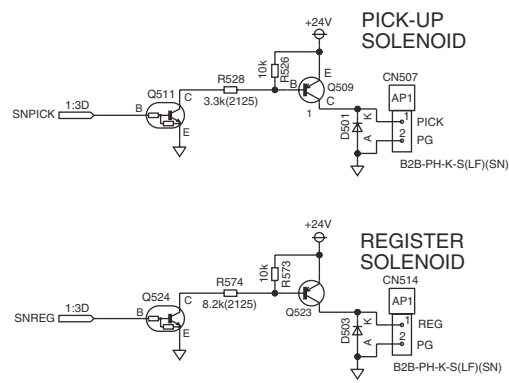
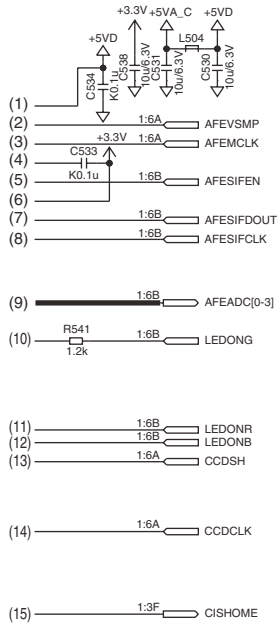
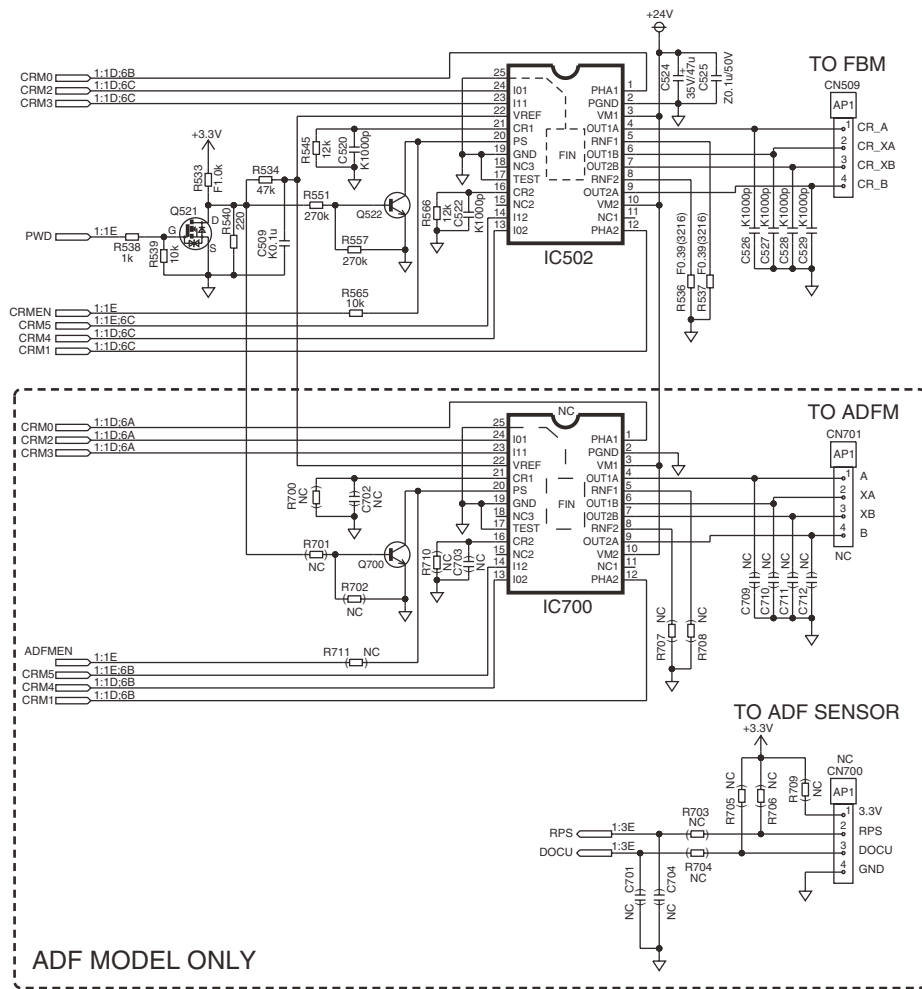

KX-MB2000HXB SCHEMATIC DIAGRAM (MAIN BOARD No.3) (2/2)

16.3. Main Board (KX-MB2010)

16.3.1. Main Board (1)

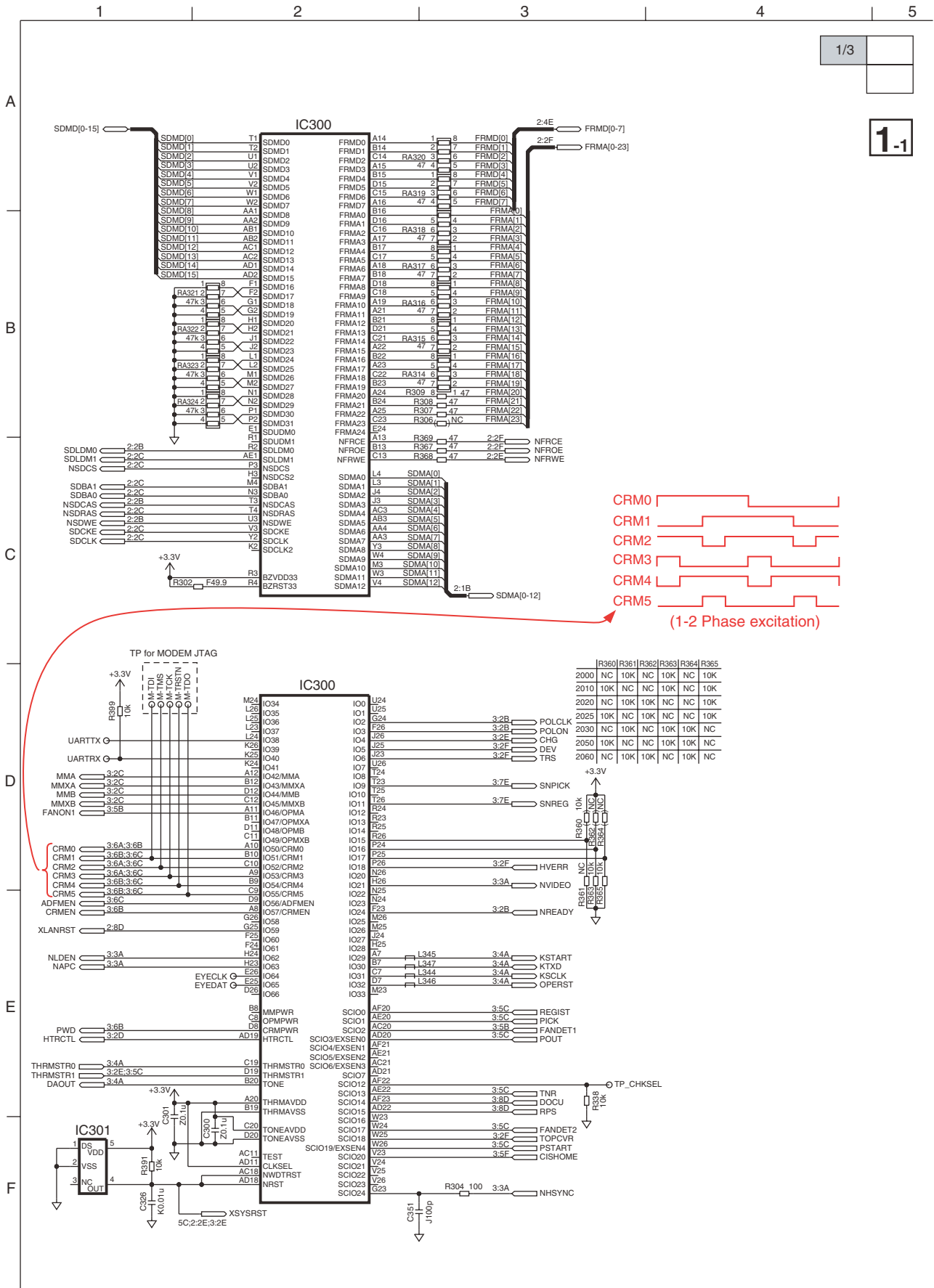

KX-MB2010HXB SCHEMATIC DIAGRAM (MAIN BOARD No.1) (1/3)

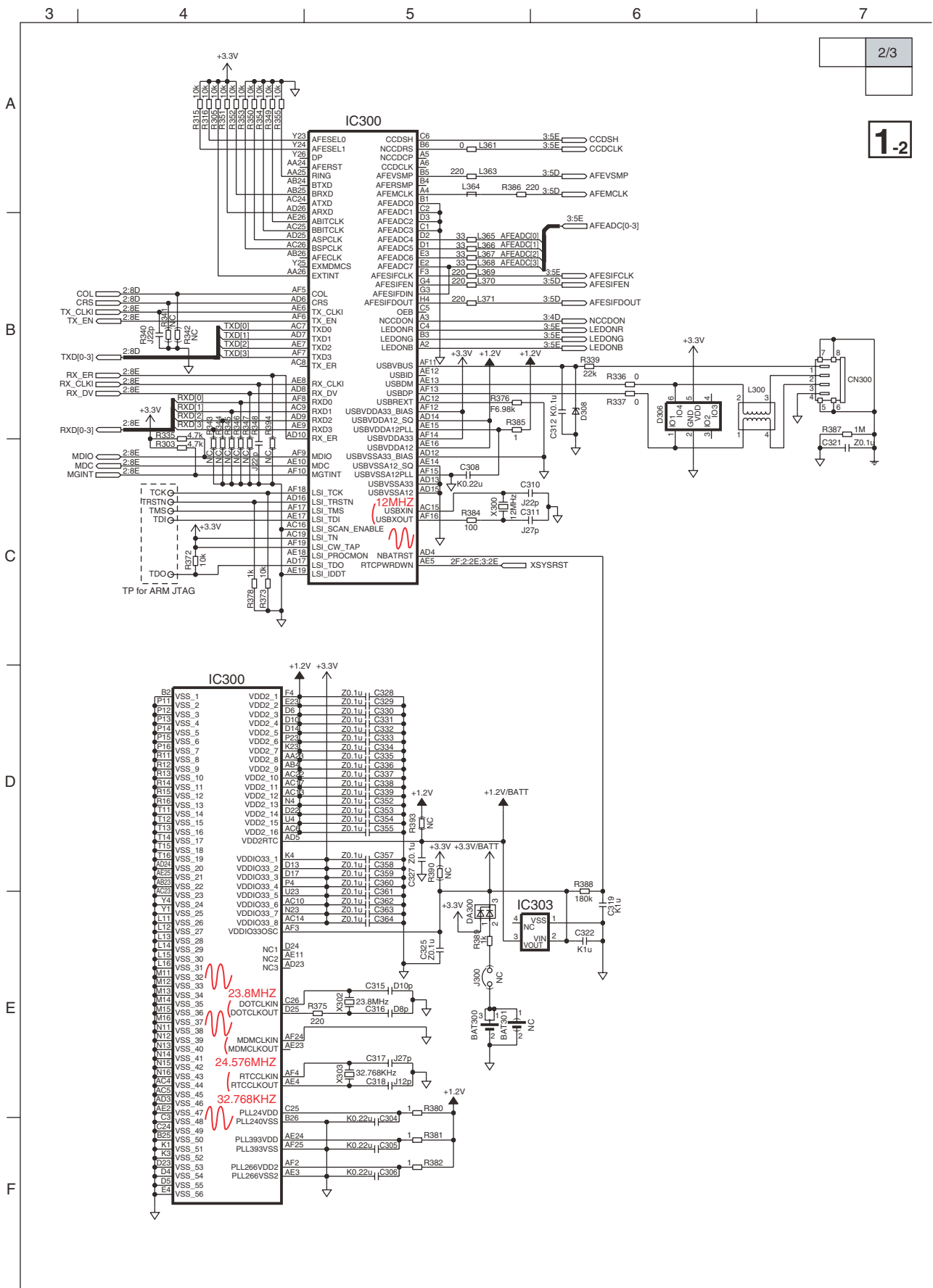

KX-MB2010HXB SCHEMATIC DIAGRAM (MAIN BOARD No.1) (2/3)

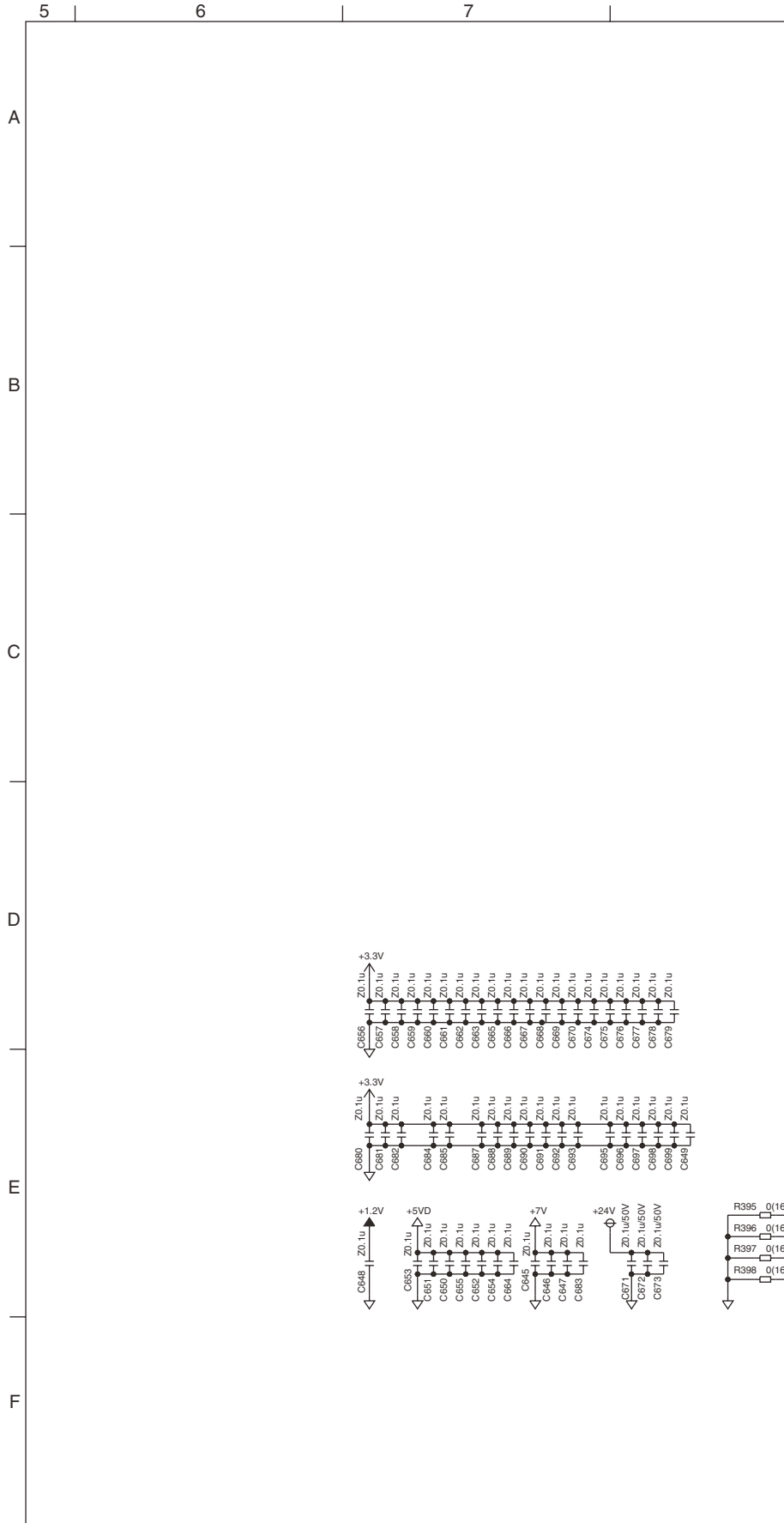

3/3

1-3

KX-MB2010HXB SCHEMATIC DIAGRAM (MAIN BOARD No.1) (3/3)

Memo

16.3.2. Main Board (2)

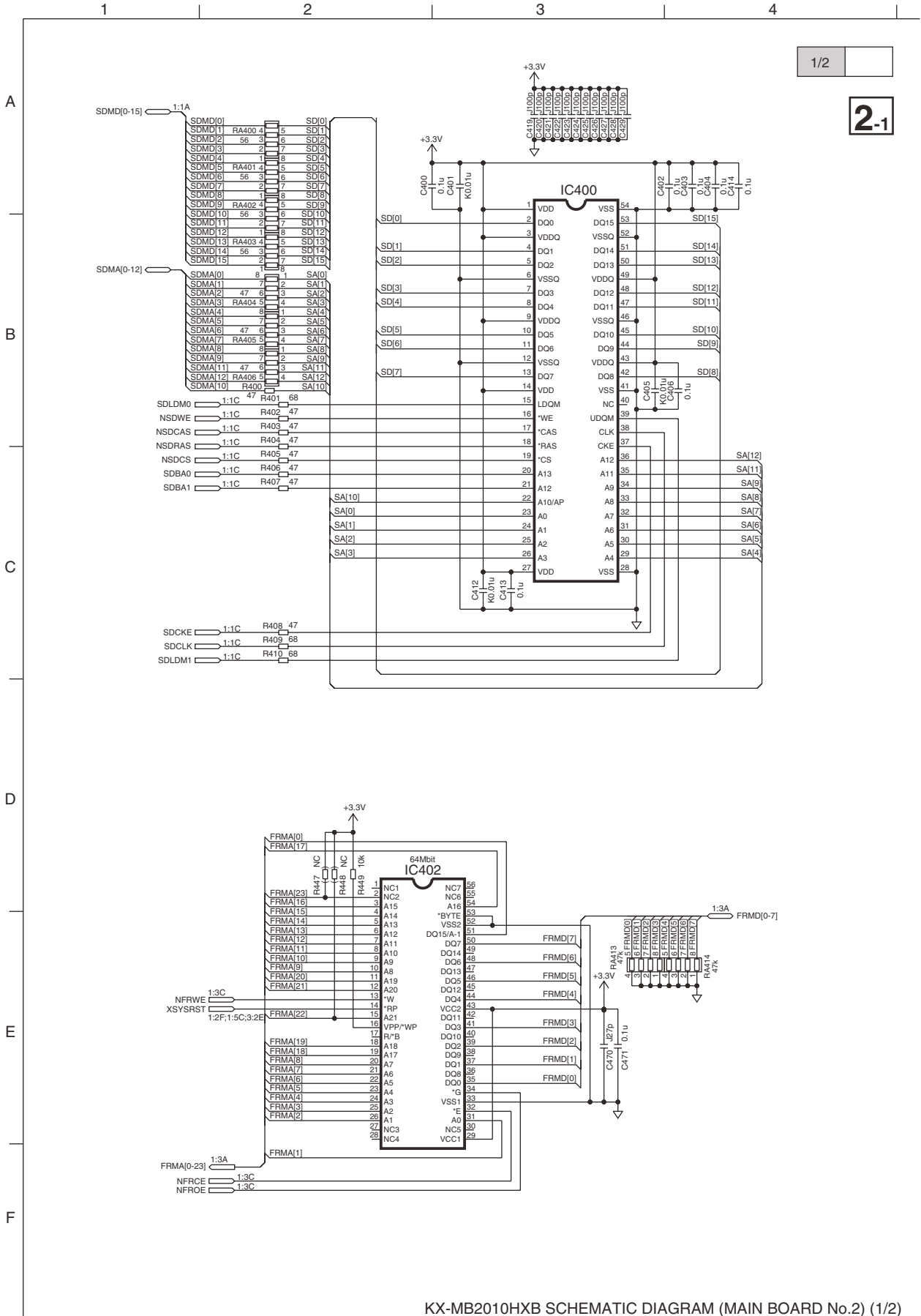

KX-MB2010HXB SCHEMATIC DIAGRAM (MAIN BOARD No.2) (1/2)

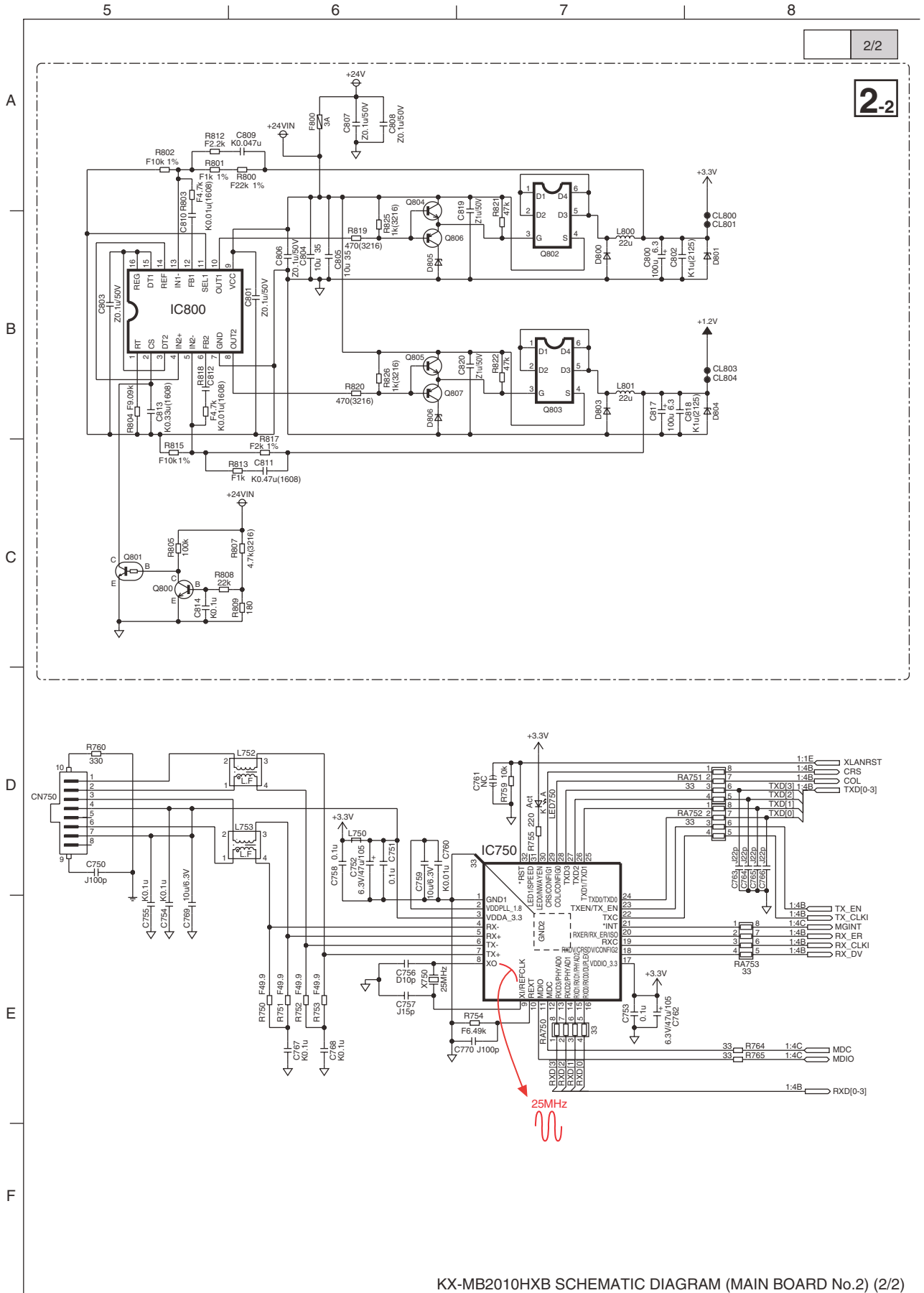

KX-MB2010HXB SCHEMATIC DIAGRAM (MAIN BOARD No.2) (2/2)

16.3.3. Main Board (3)

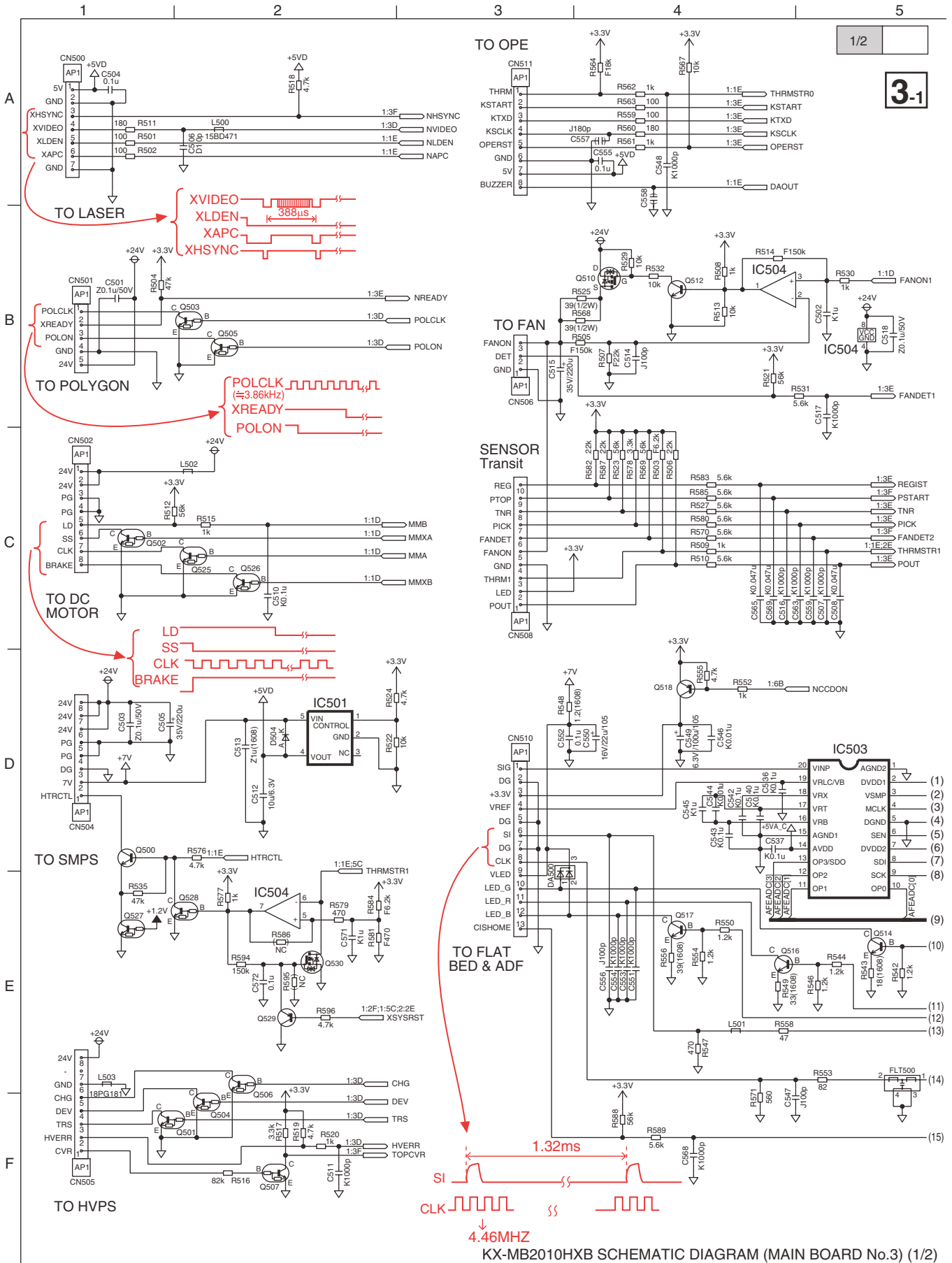

KX-MB2010HXB SCHEMATIC DIAGRAM (MAIN BOARD No.3) (1/2)

A
B
C
D
E
F

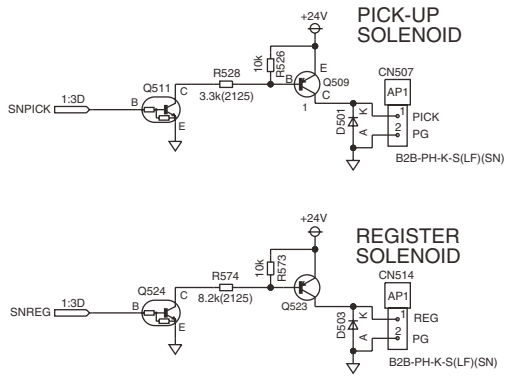
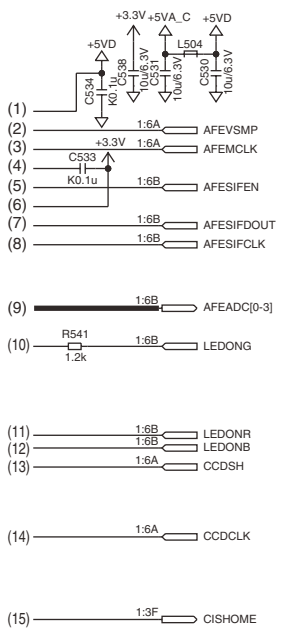
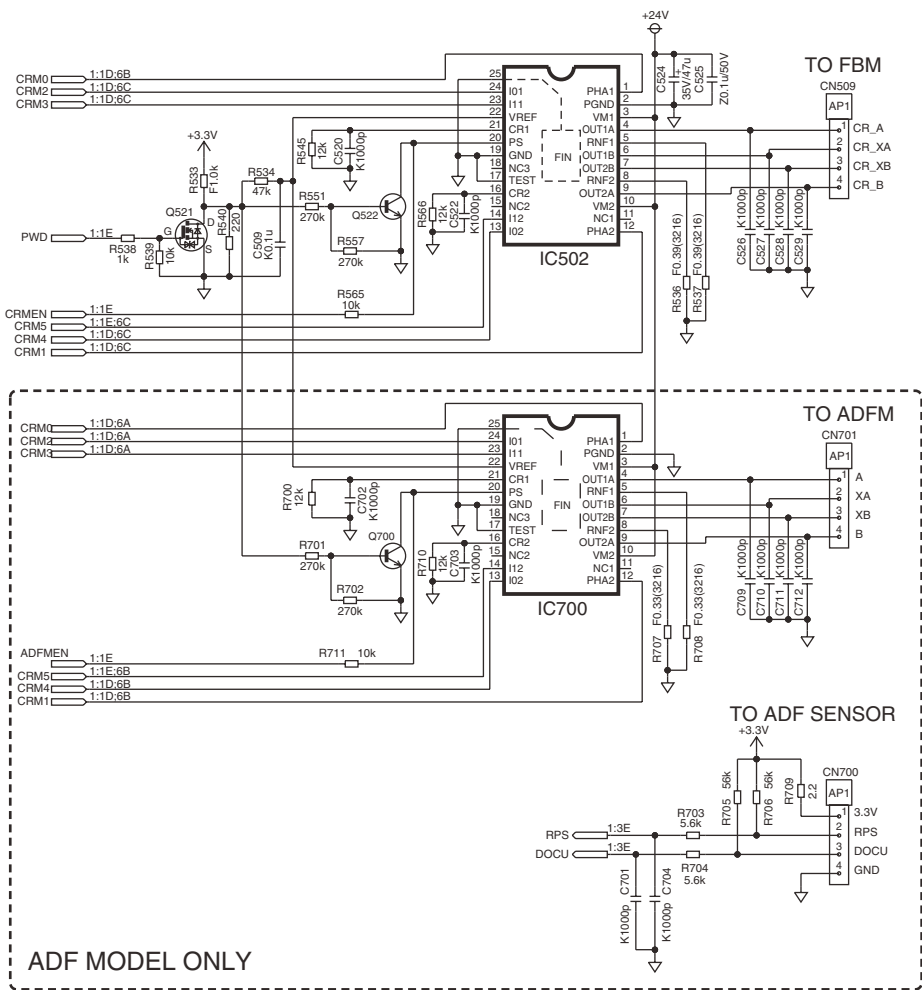

KX-MB2010HXB SCHEMATIC DIAGRAM (MAIN BOARD No.3) (2/2)

16.4. Operation Board

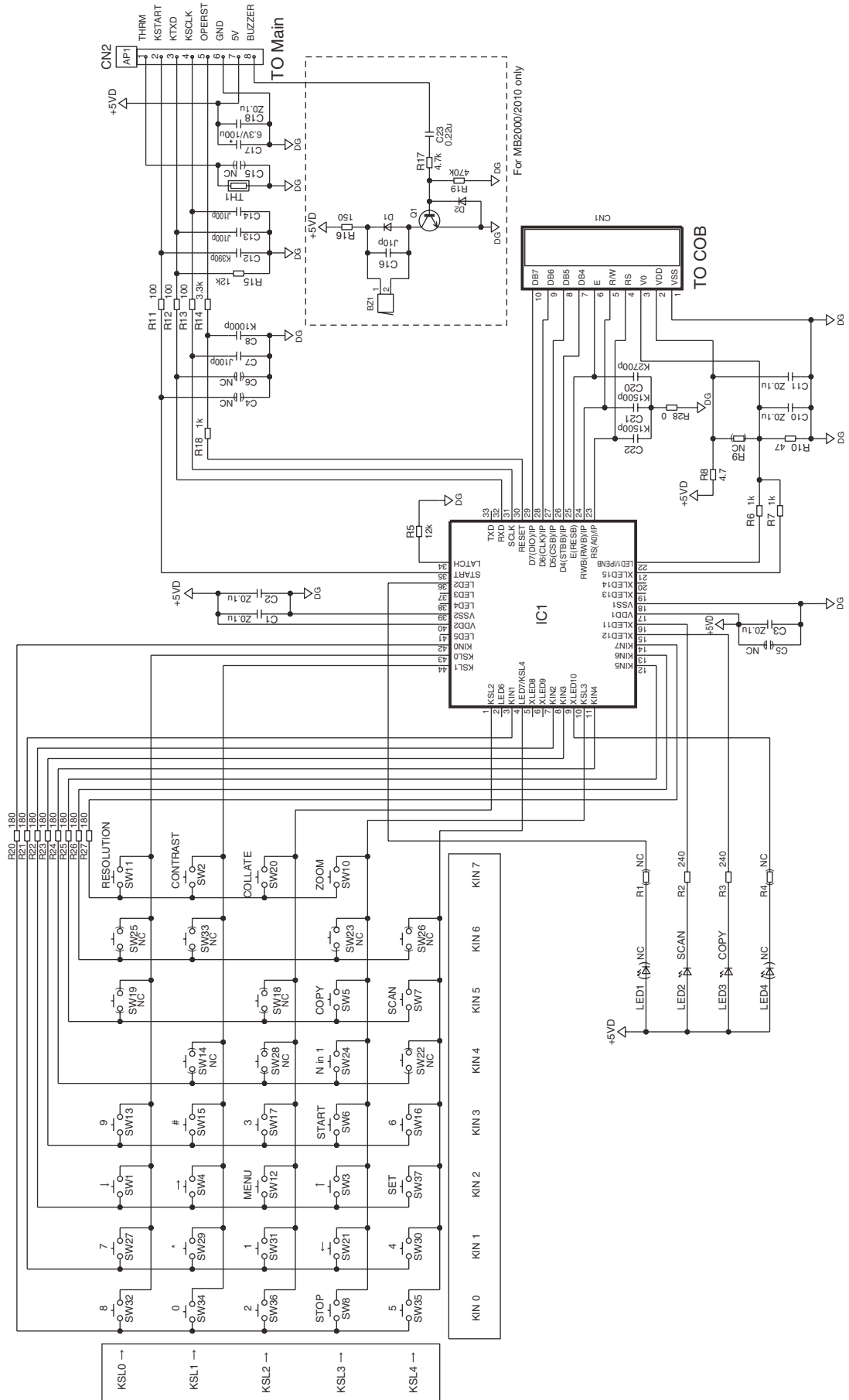

KX-MB2000HXB / KX-MB2010HXB OPERATION BOARD

16.5. Sensor Board

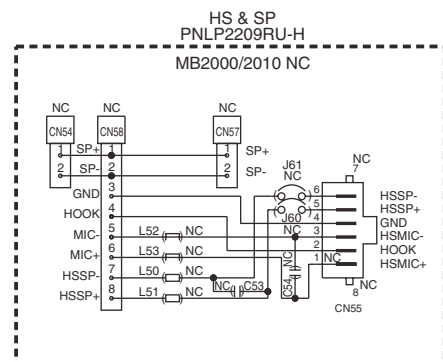
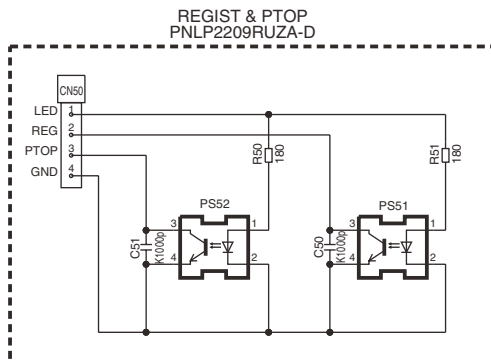
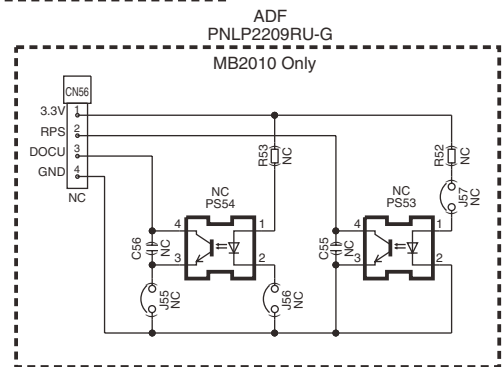
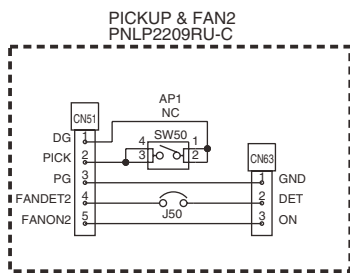
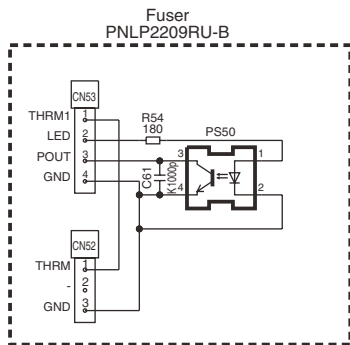
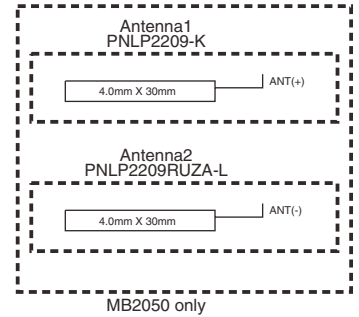
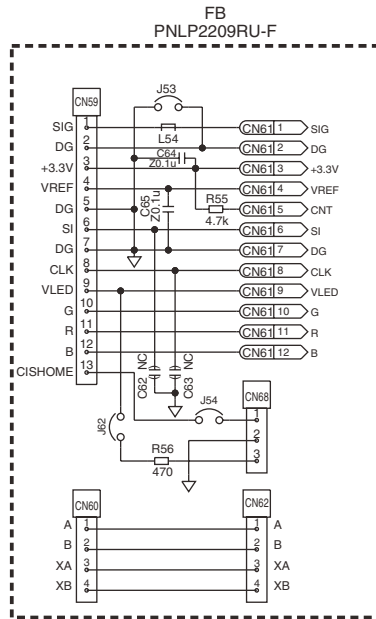
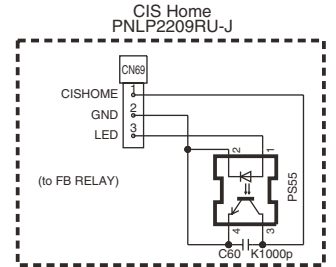
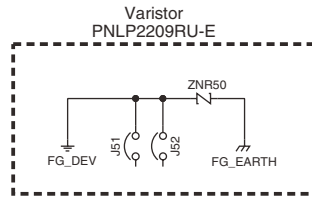
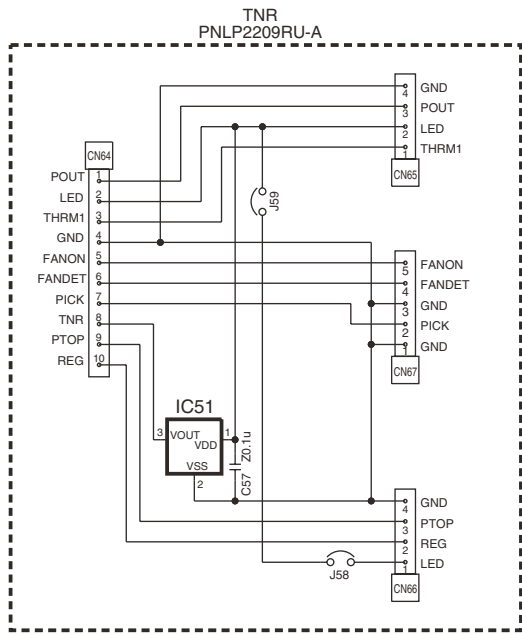

16.6. High Voltage Power Supply Board

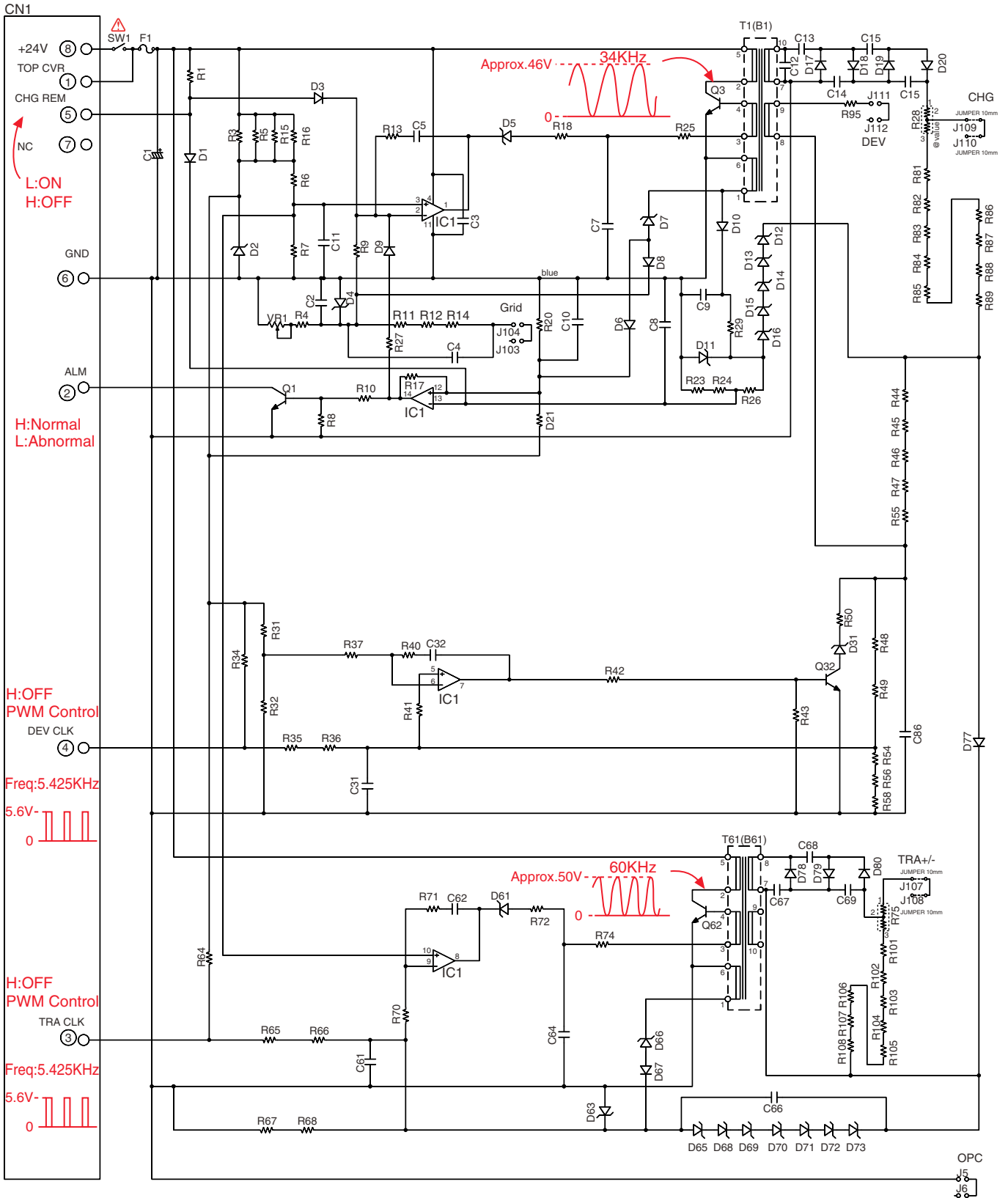

KX-MB2000HXB / KX-MB2010HXB HIGH VOLTAGE POWER SUPPLY BOARD

16.7. Low Voltage Power Supply Board

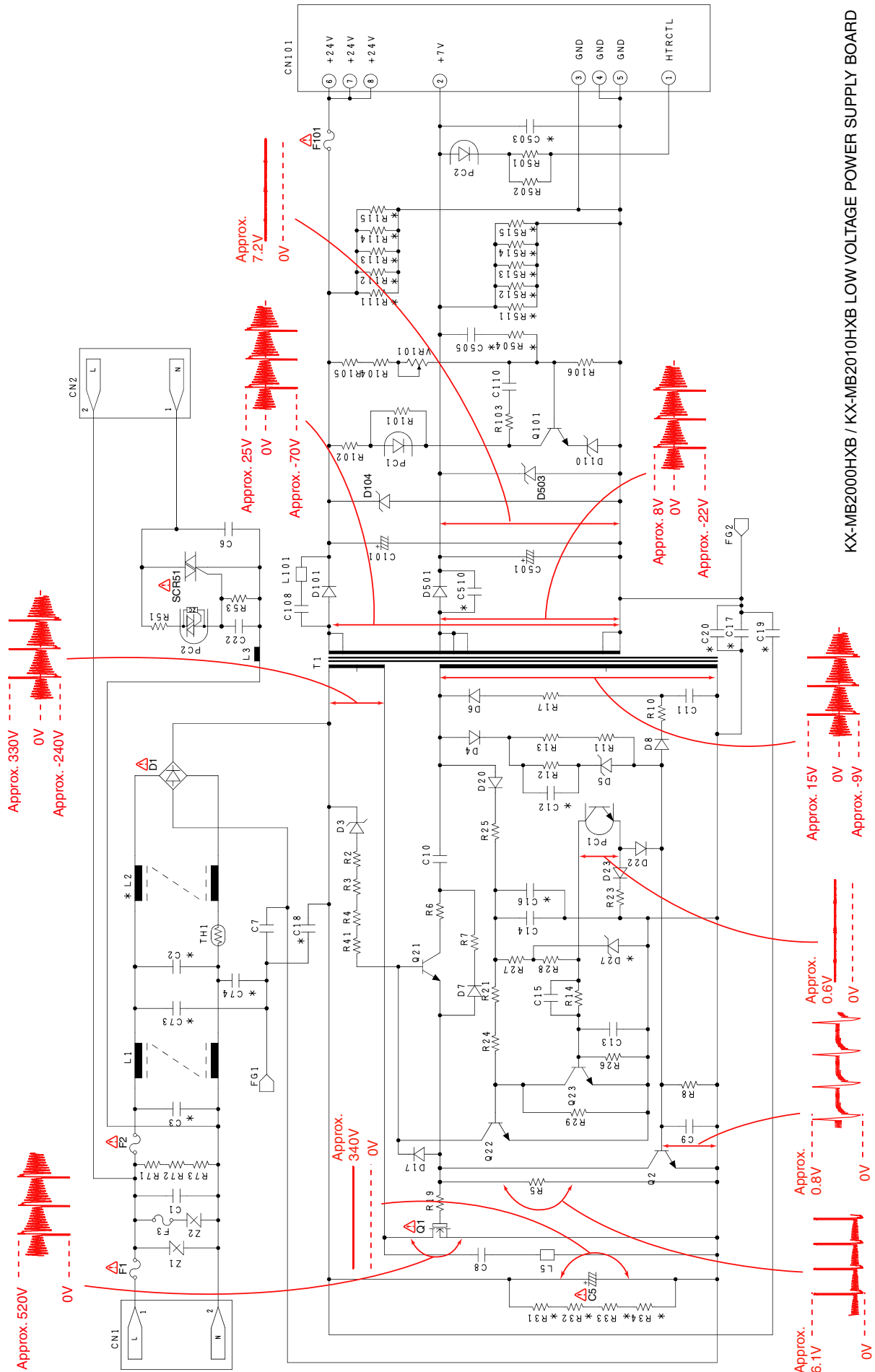

KX-MB2000HXB / KX-MB2010HXB LOW VOLTAGE POWER SUPPLY BOARD

Memo

17 Printed Circuit Board

17.1. Main Board

17.1.1. Main Board: Component View

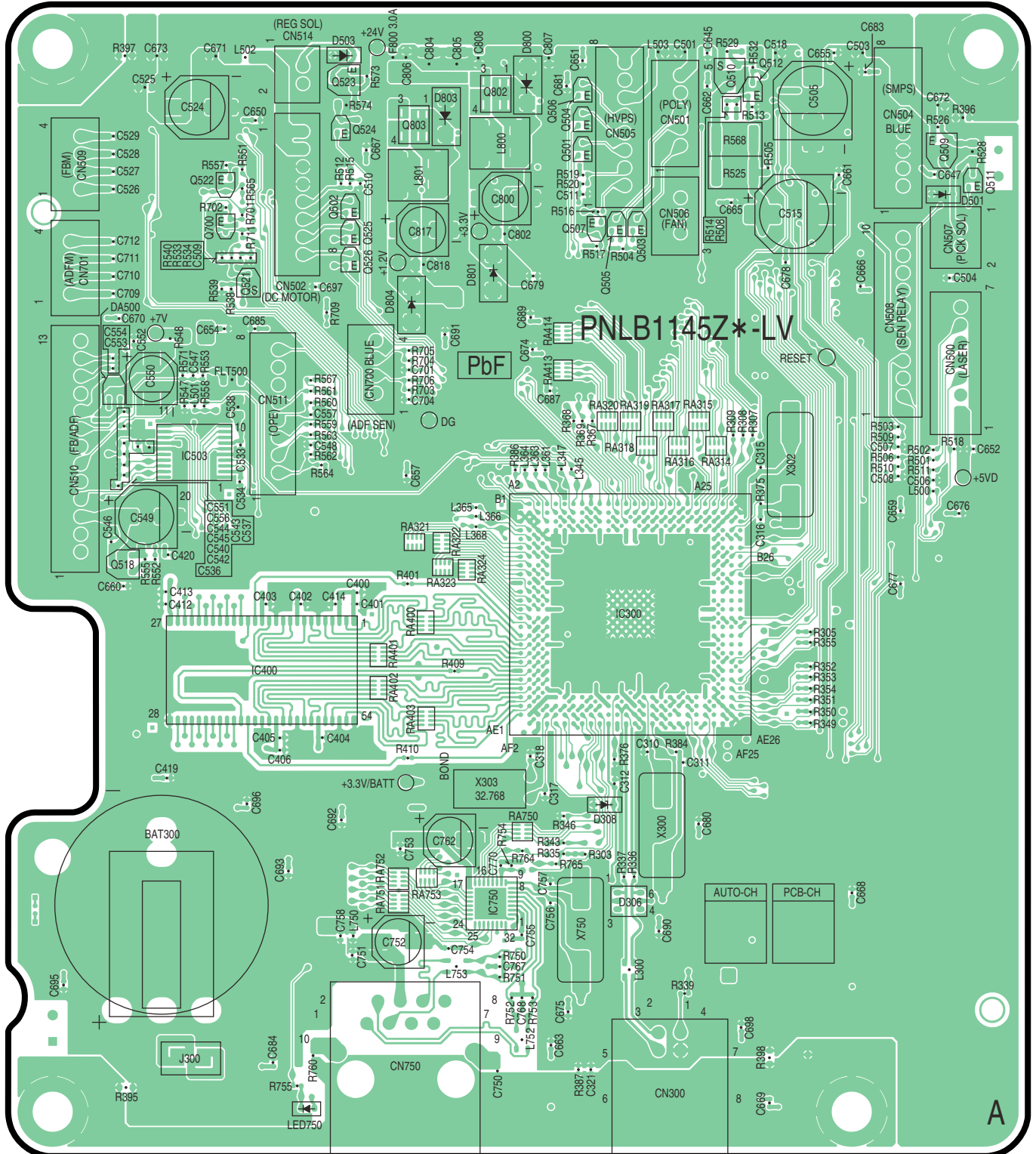

KX-MB2000HXB / KX-MB2010HXB MAIN BOARD COMPONENT VIEW

17.1.2. Main Board: Bottom View

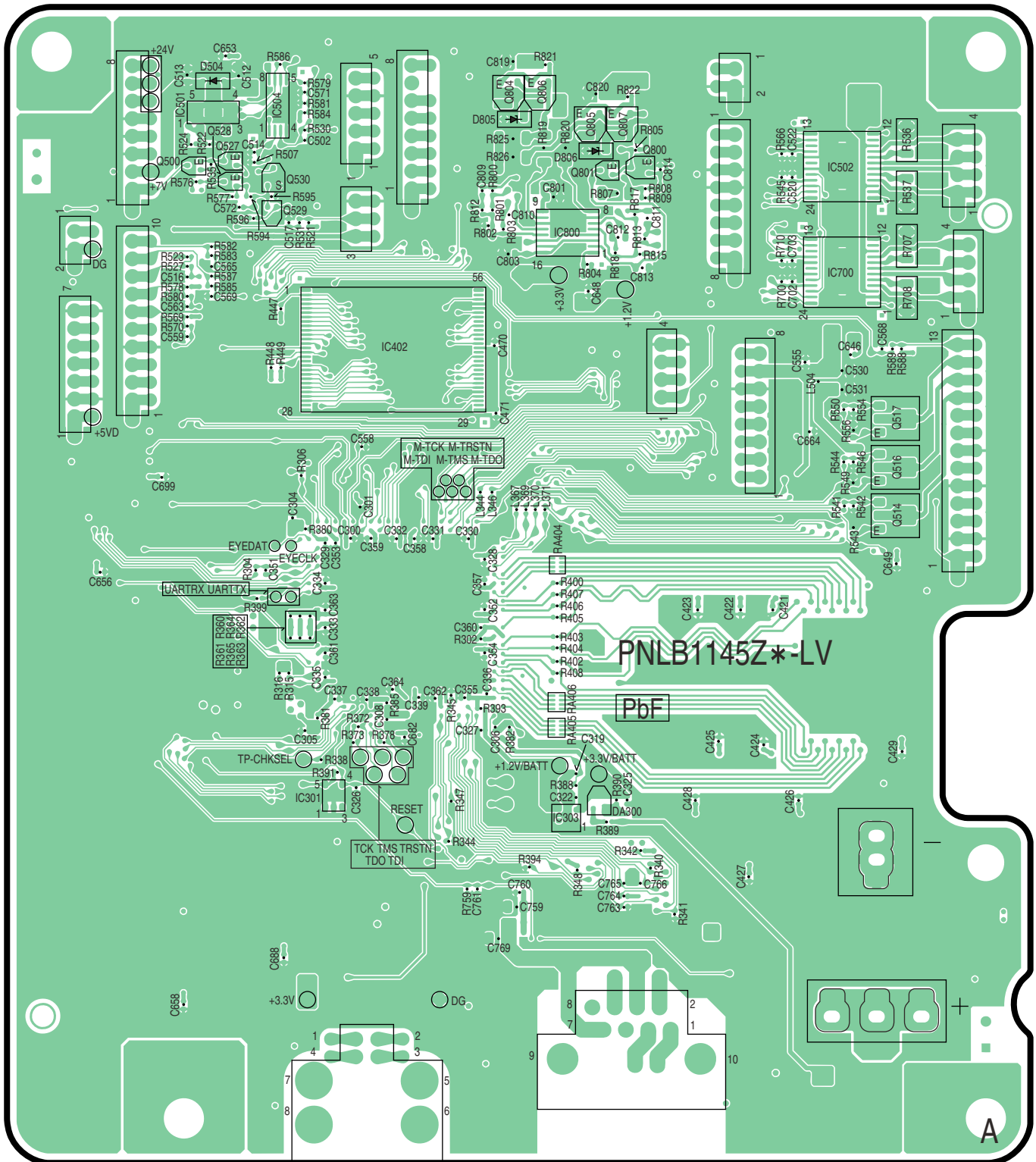

KX-MB2000HXB / KX-MB2010HXB MAIN BOARD BOTTOM VIEW

17.2. Operation Board

17.2.1. Operation Board

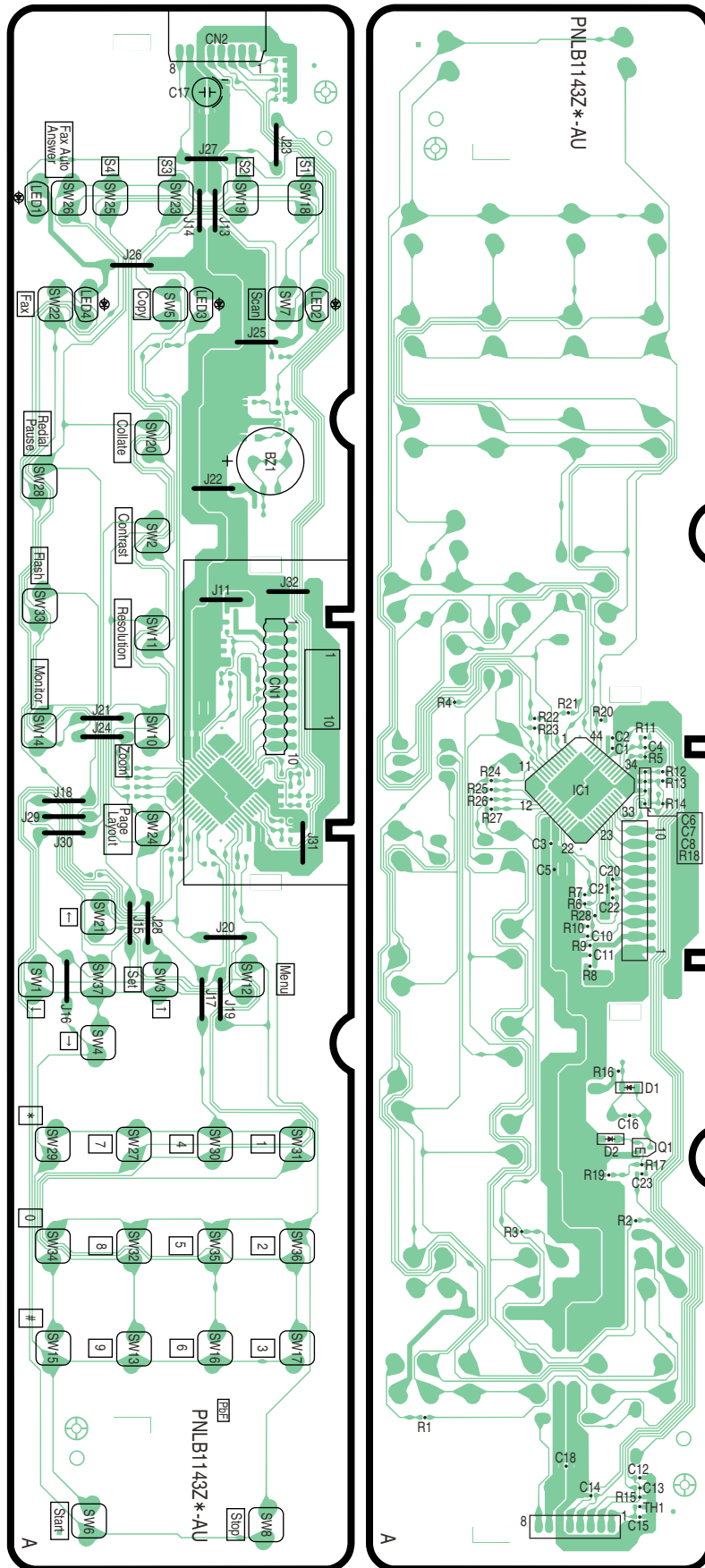

KX-MB2000HXB / KX-MB2010HXB OPERATION BOARD

17.3. Sensor Board

17.3.1. Toner Sensor Board

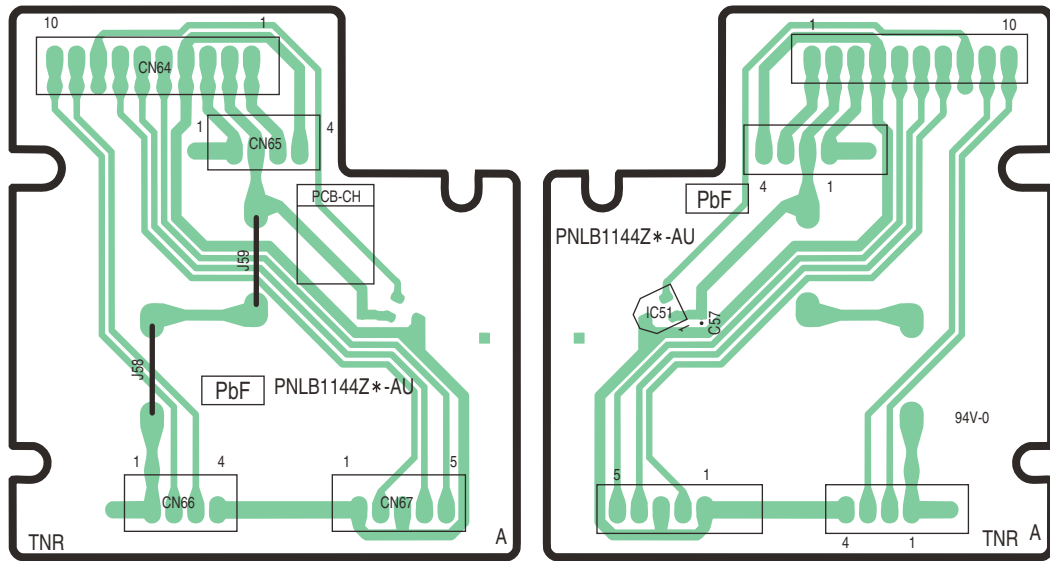

KX-MB2000HXB / KX-MB2010HXB TONER SENSOR BOARD

17.3.2. Fuser Board

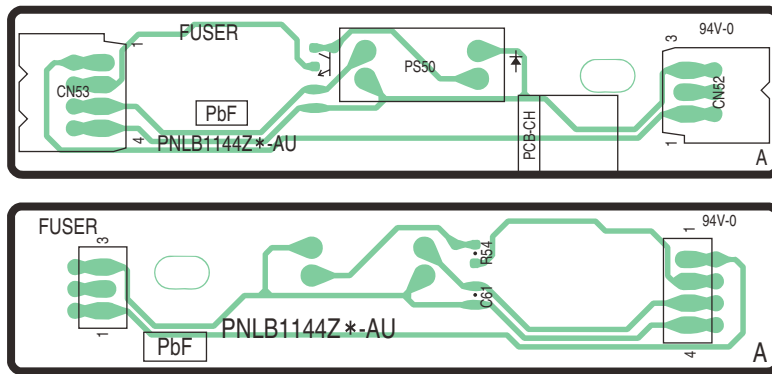

KX-MB2000HXB / KX-MB2010HXB FUSER SENSOR BOARD

17.3.3. Pickup Sensor Board

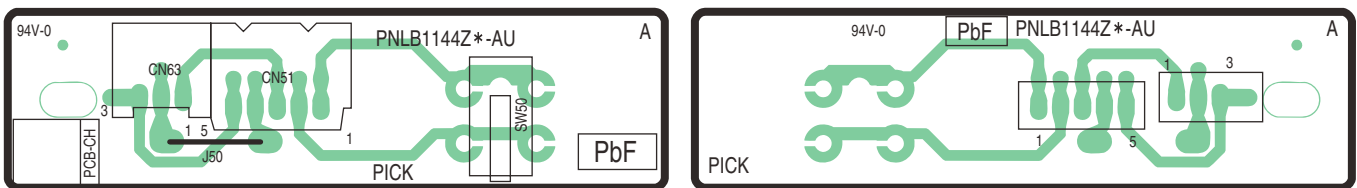

KX-MB2000HXB / KX-MB2010HXB PICK UP SENSOR BOARD

17.3.4. Registration Sensor Board

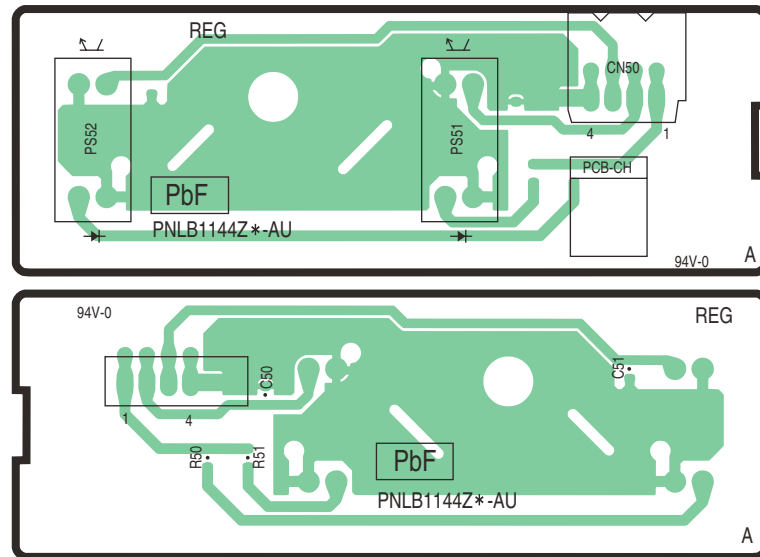

KX-MB2000HXB / KX-MB2010HXB REGISTRATION SENSOR BOARD

17.3.5. Varistor Sensor Board

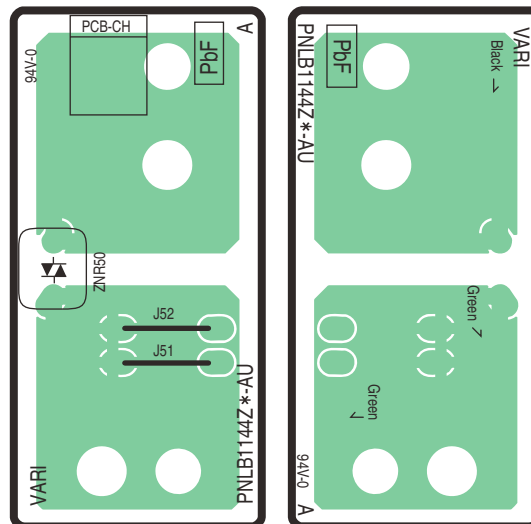

KX-MB2000HXB / KX-MB2010HXB VARISTOR SENSOR BOARD

17.3.6. Flatbed Relay Board

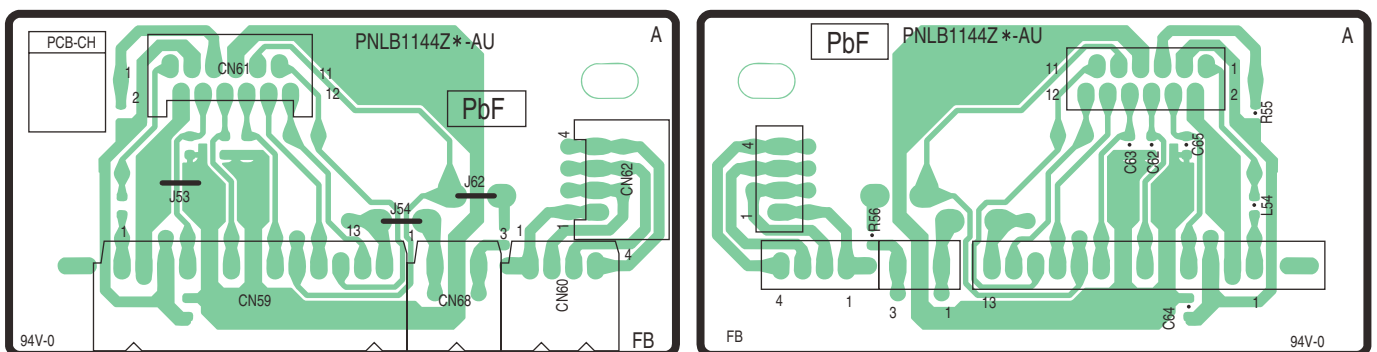

KX-MB2000HXB / KX-MB2010HXB FB RELAY BOARD

17.3.7. ADF Sensor Board (KX-MB2010 ONLY)

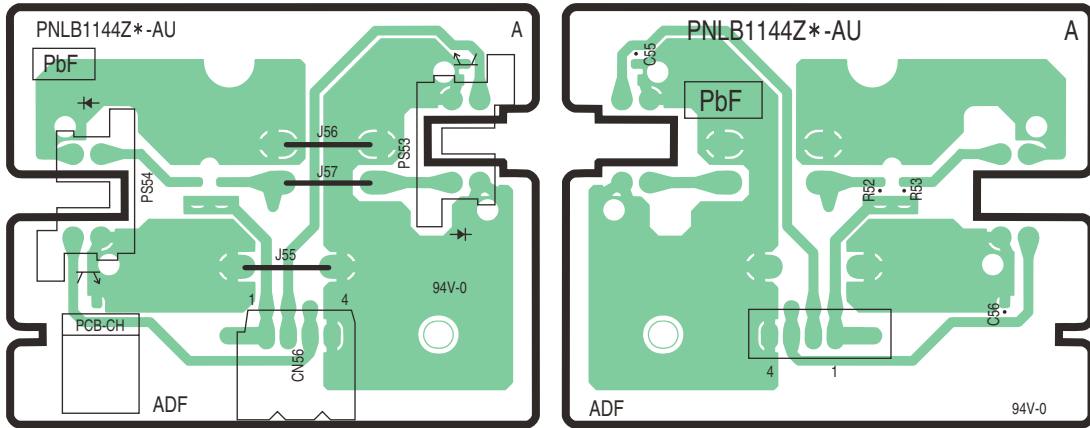

KX-MB2010HXB ADF SENSOR BOARD

17.3.8. CIS Home Sensor Board

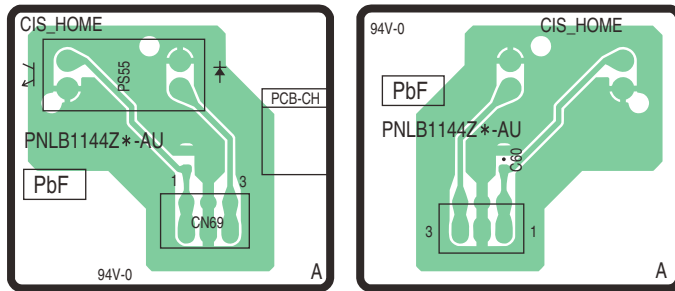

KX-MB2000HXB / KX-MB2010HXB CIS HOME SENSOR BOARD

17.4. High Voltage Power Supply Board

17.4.1. HIGH VOLTAGE POWER SUPPLY BOARD: COMPONENT VIEW

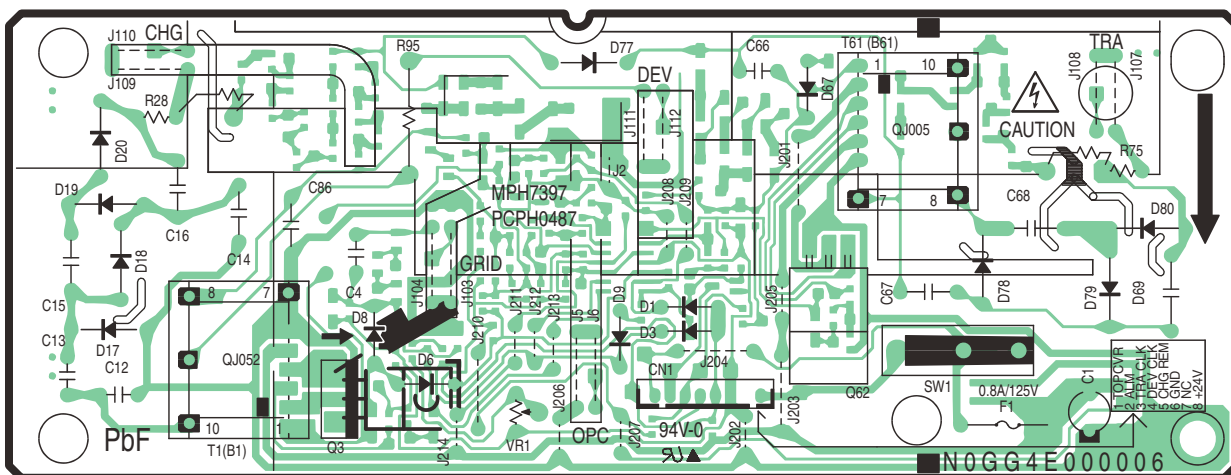

KX-MB2000HXB / KX-MB2010HXB HIGH VOLTAGE POWER SUPPLY BOARD (COMPONENT VIEW)

17.4.2. HIGH VOLTAGE POWER SUPPLY BOARD: BOTTOM VIEW

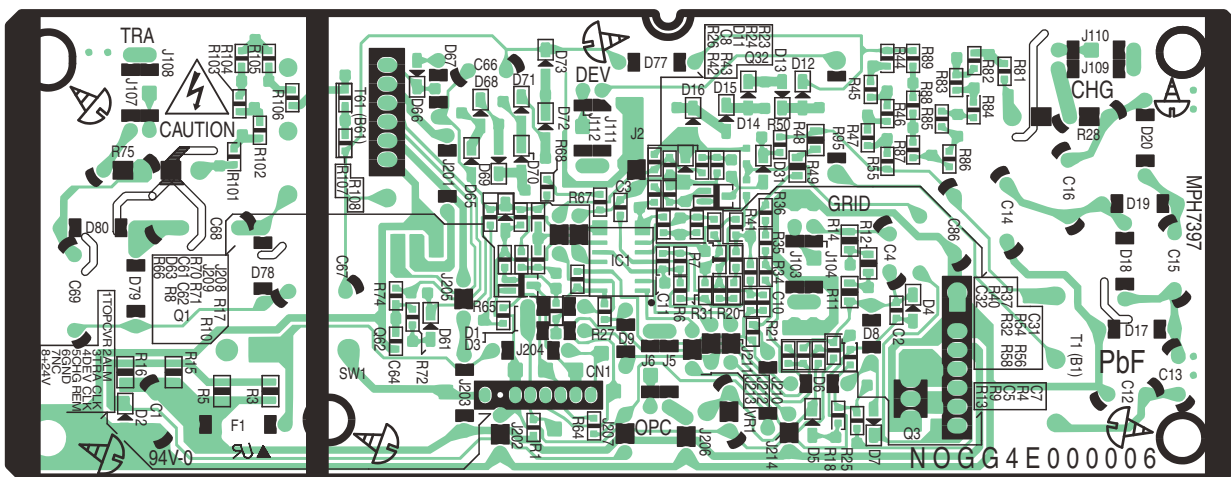

KX-MB2000HXB / KX-MB2010HXB HIGH VOLTAGE POWER SUPPLY BOARD (BOTTOM VIEW)

17.5. Low Voltage Power Supply Board

17.5.1. LOW VOLTAGE POWER SUPPLY BOARD: COMPONENT VIEW

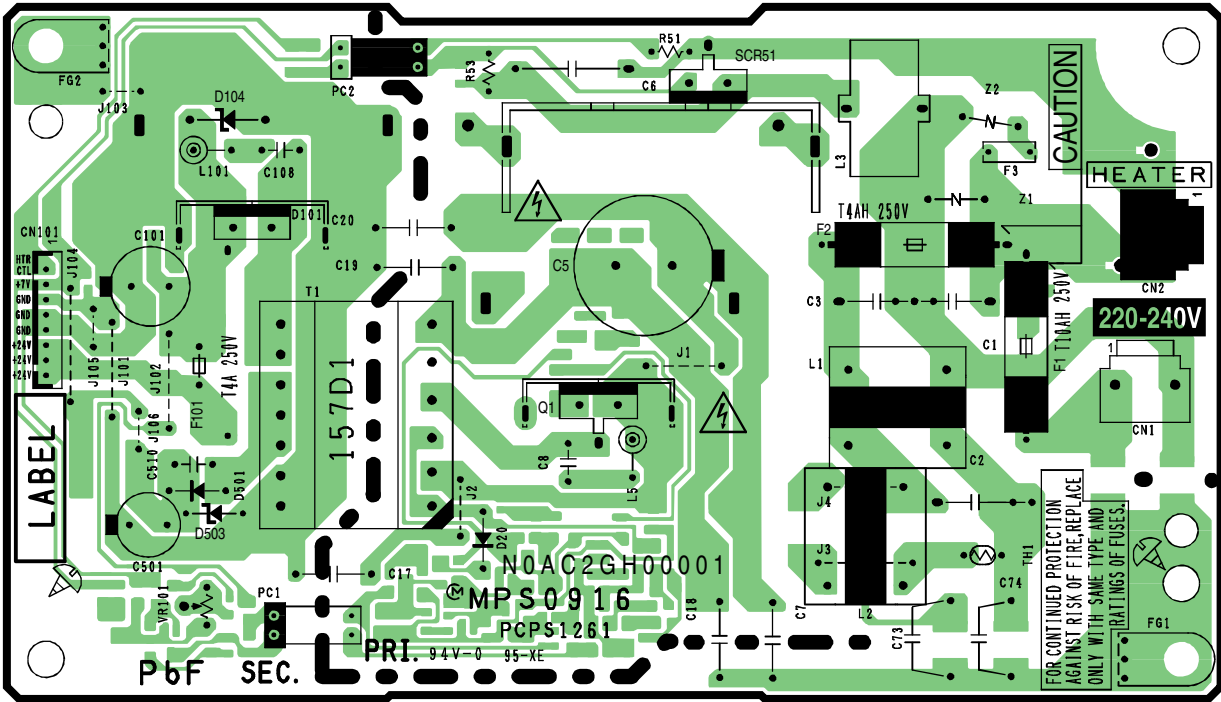

KX-MB2000HXB / KX-MB2010HXB LOW VOLTAGE POWER SUPPLY BOARD (COMPONENT VIEW)

17.5.2. LOW VOLTAGE POWER SUPPLY BOARD: BOTTOM VIEW

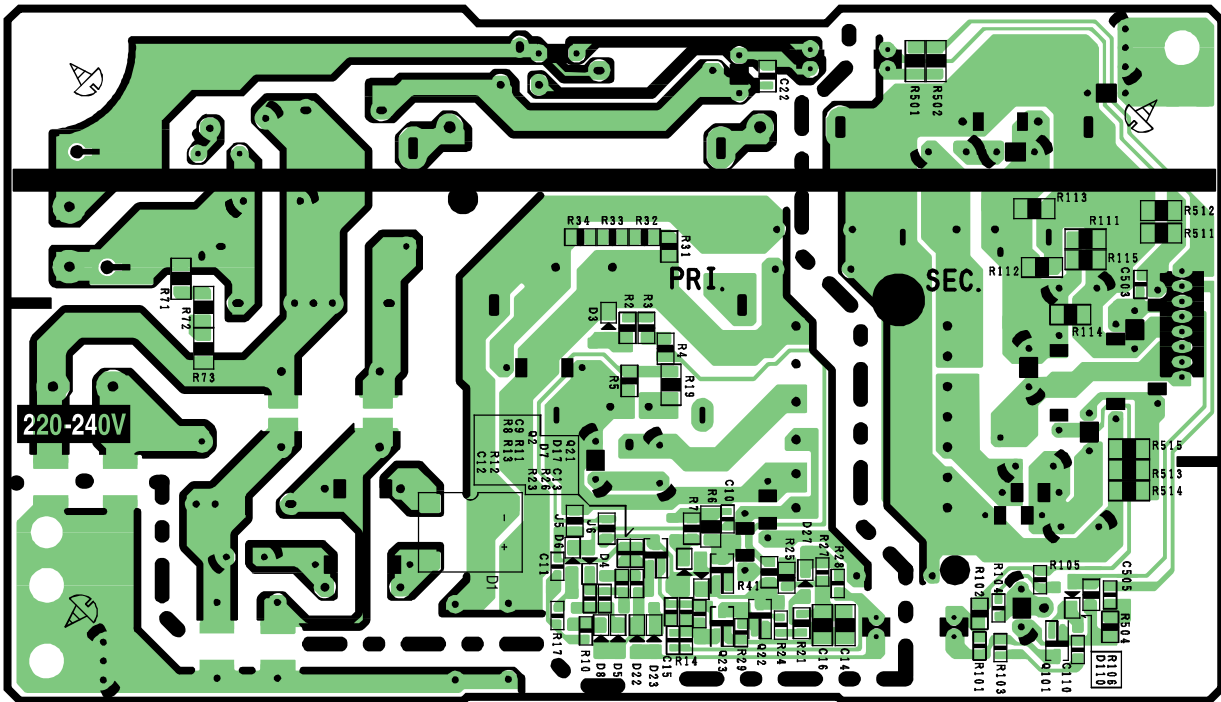

KX-MB2000HXB / KX-MB2010HXB LOW VOLTAGE POWER SUPPLY BOARD (BOTTOM VIEW)

18 Exploded View and Replacement Parts List

18.1. Cabinet, Mechanical and Electrical Parts Location

18.1.1. Operation Panel Section

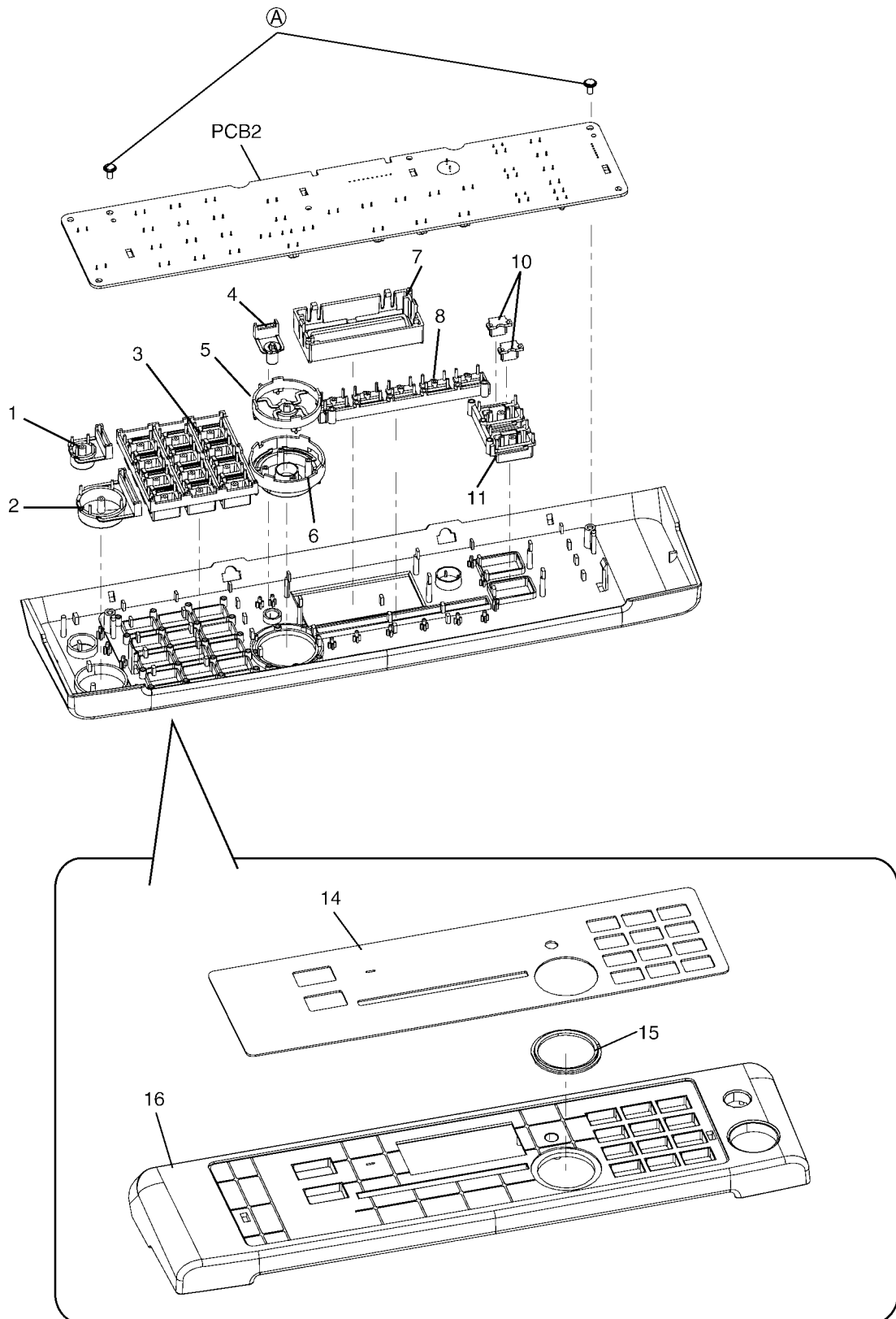

This pictured model is KX-MB2010.

18.1.2. ADF Section (KX-MB2010)

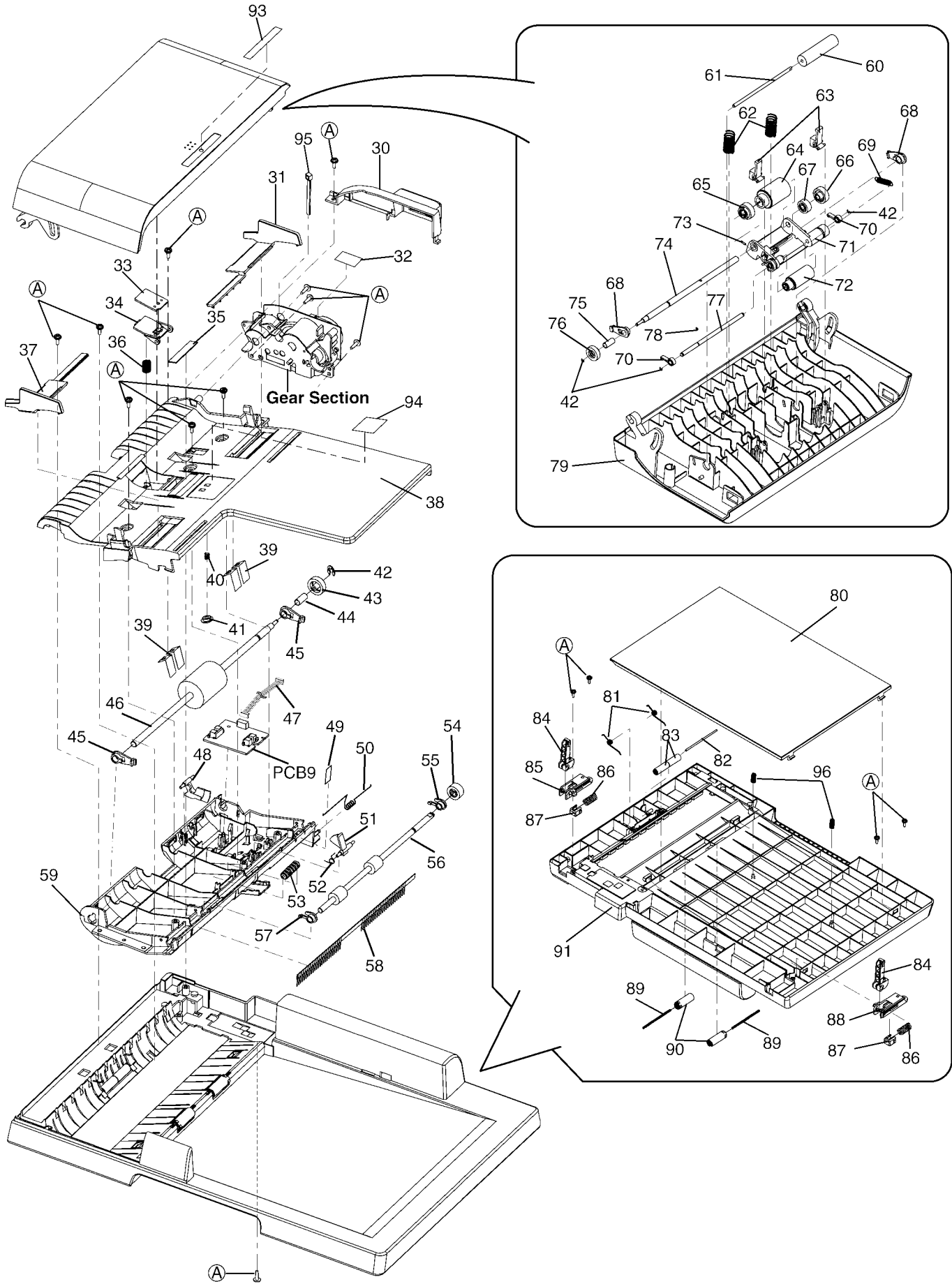

18.1.3. Flatbed Section (KX-MB2000)

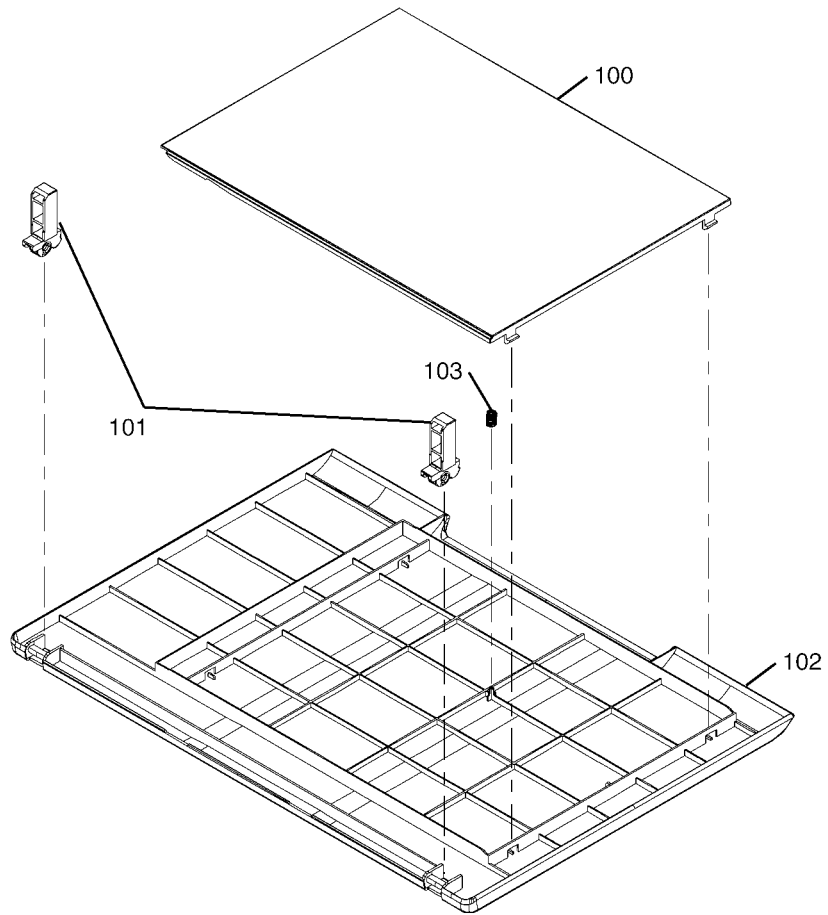

18.1.4. ADF Gear Section (KX-MB2010)

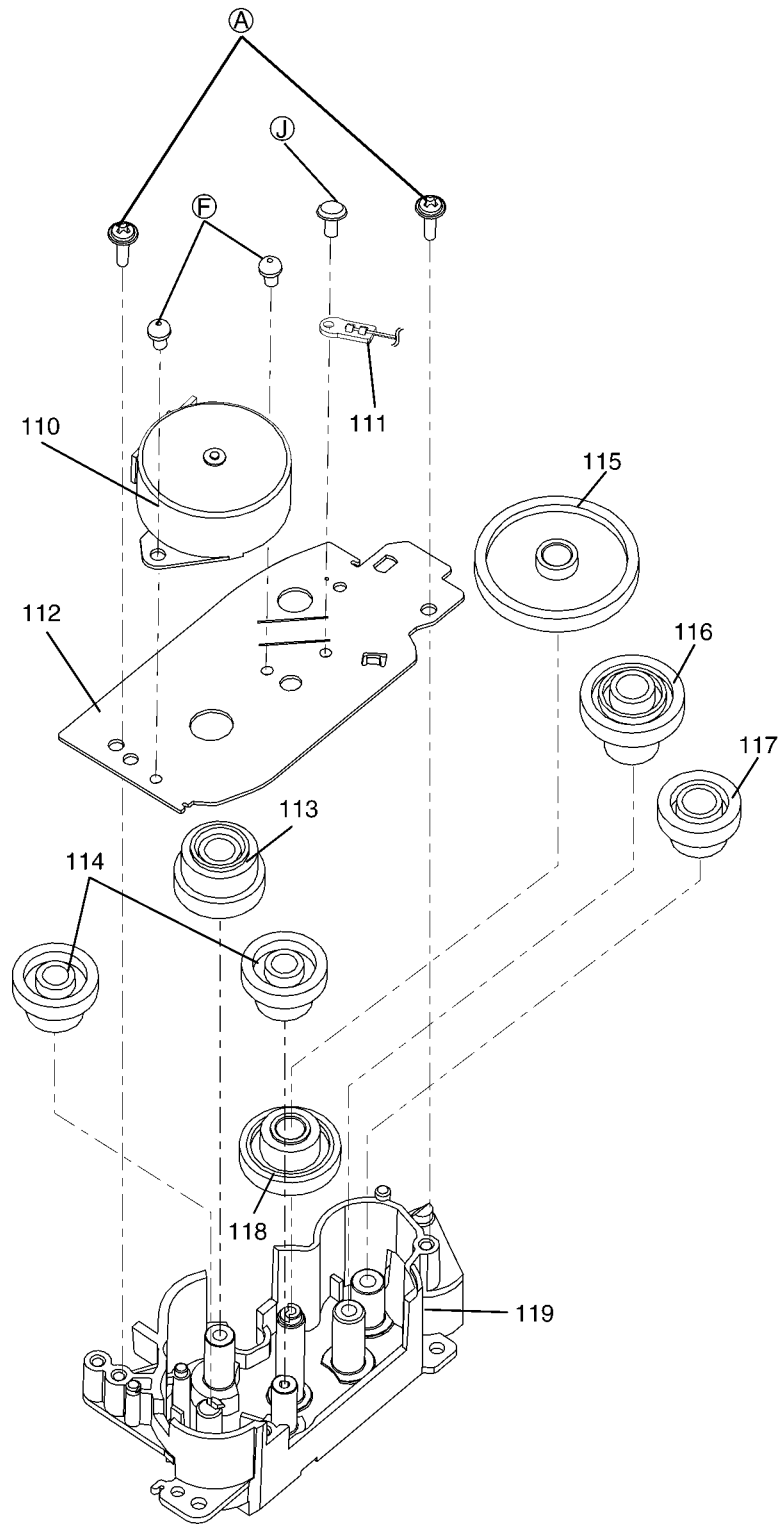

18.1.5. Top Cover Section

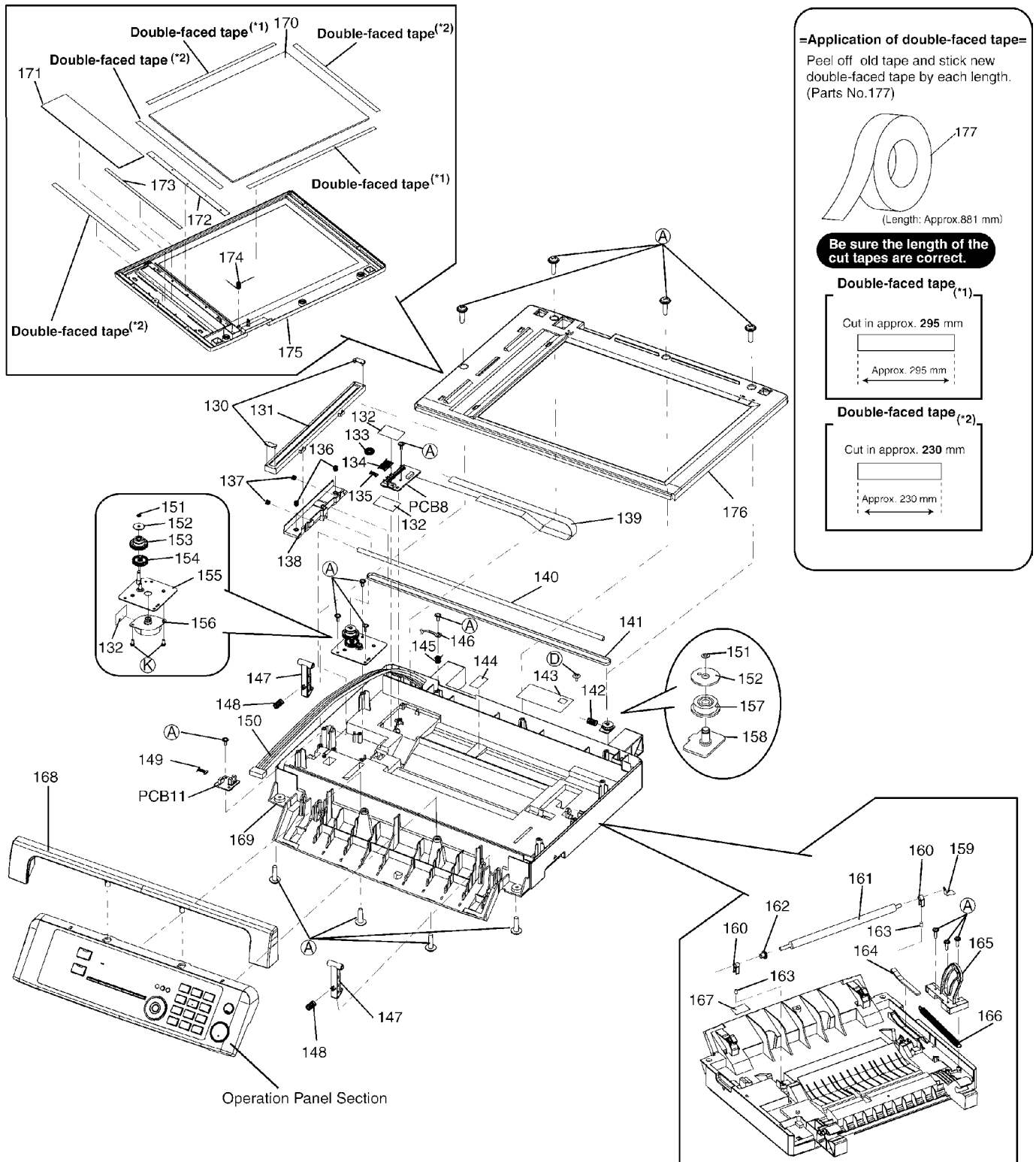

18.1.6. Main Cabinet Section

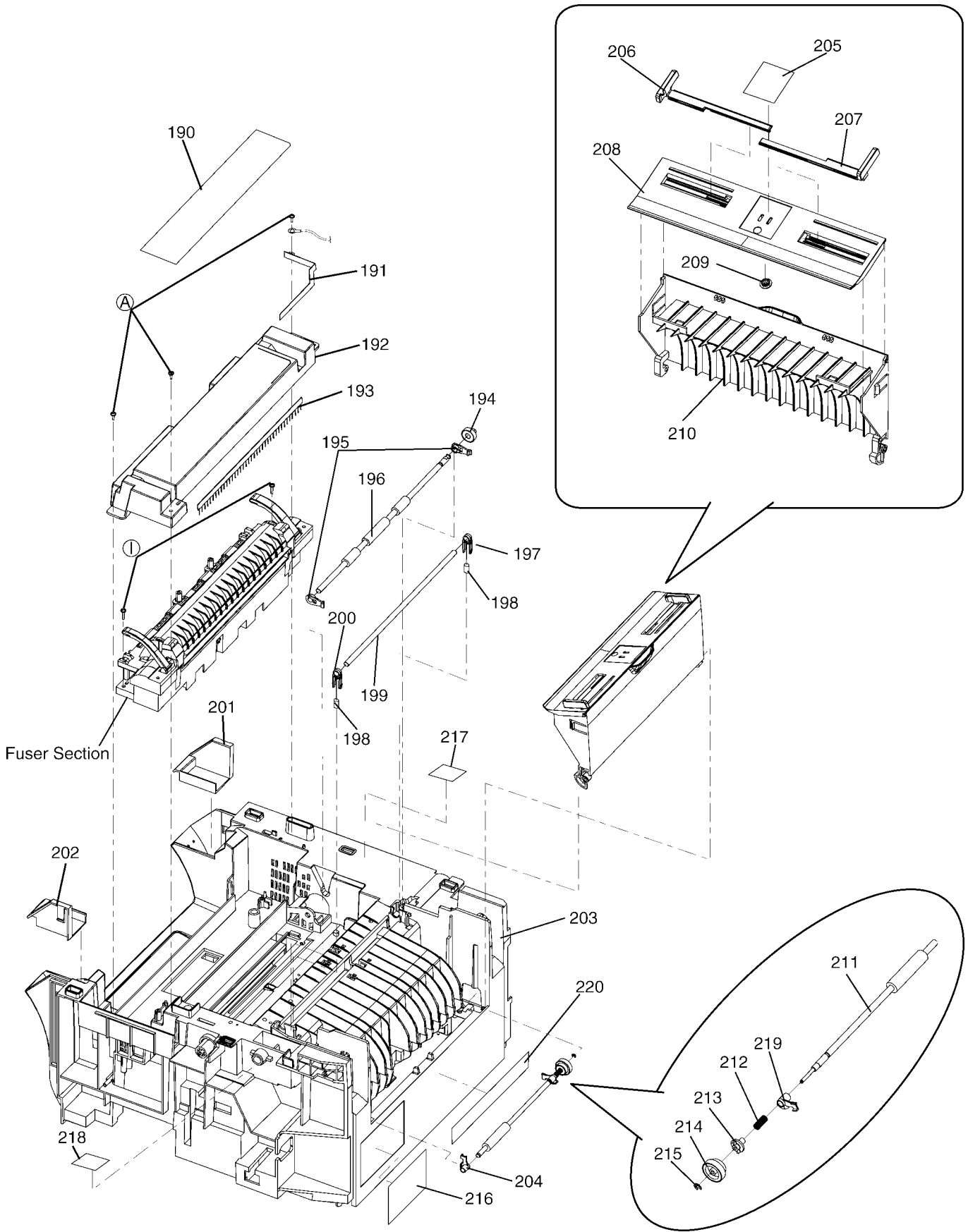

18.1.7. Fuser Section

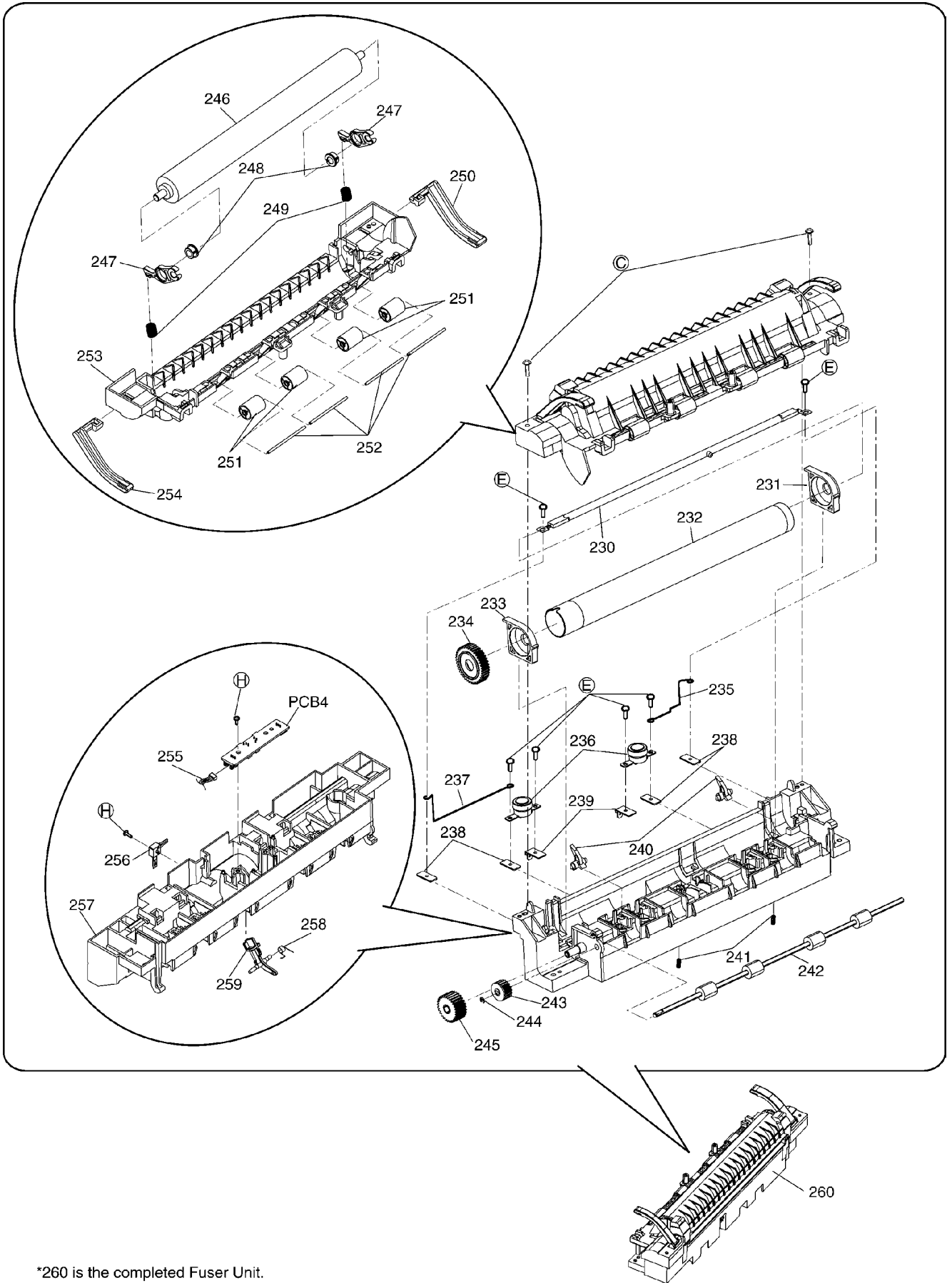

*260 is the completed Fuser Unit.

18.1.8. Bottom Cabinet Section (1)

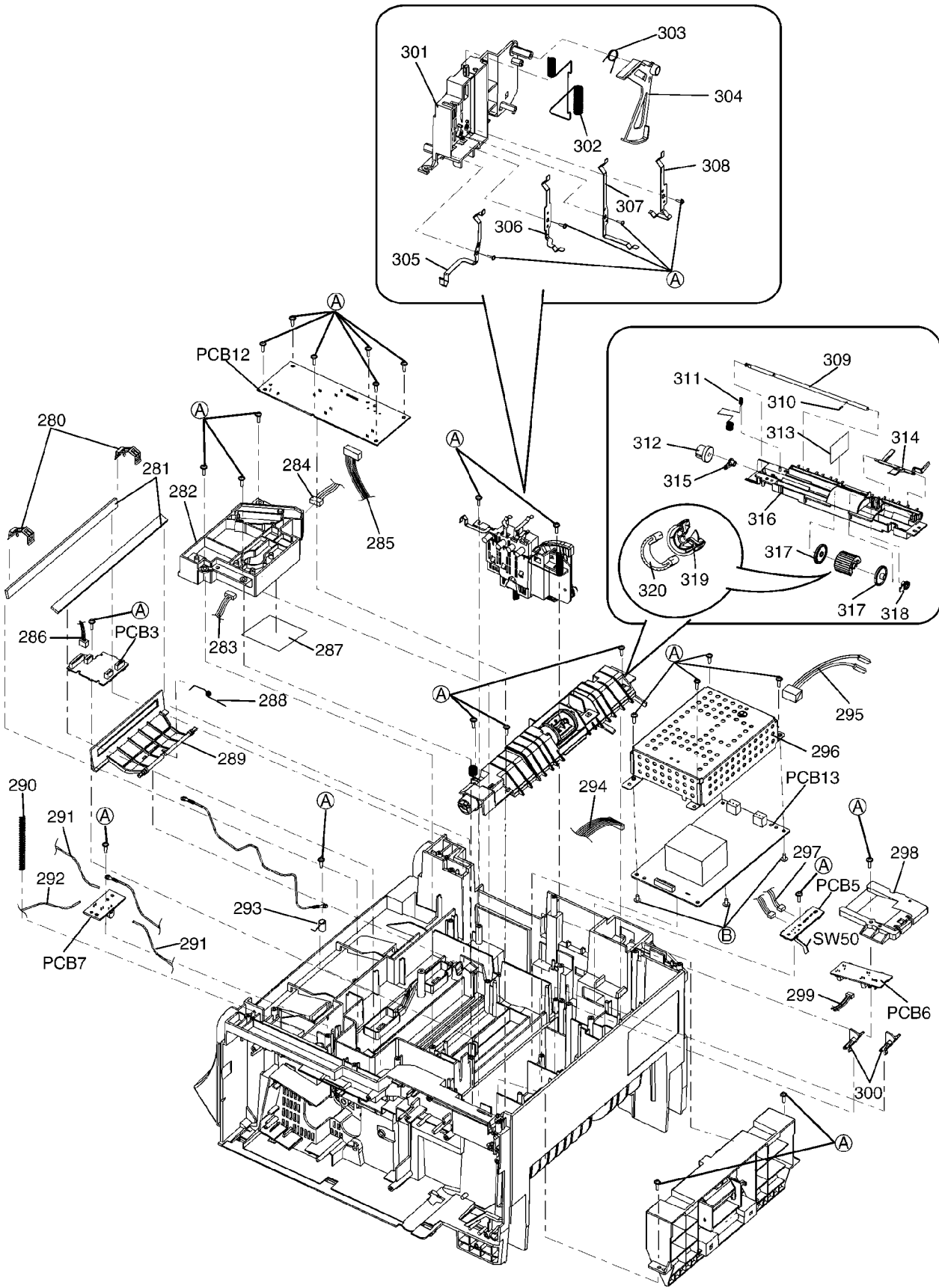

18.1.9. Separation (DFP) Roller Section

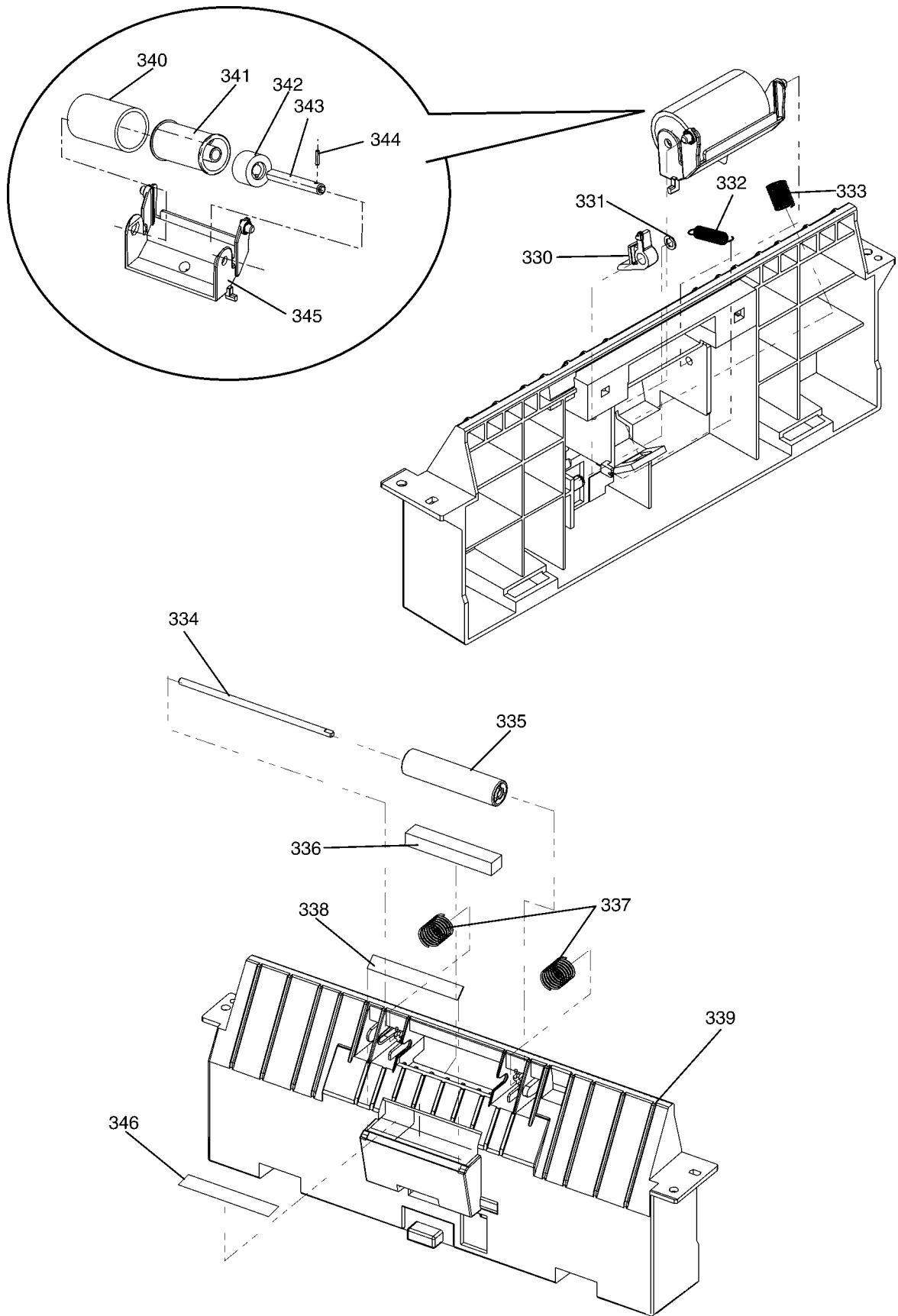

18.1.10. Side Cabinet Section

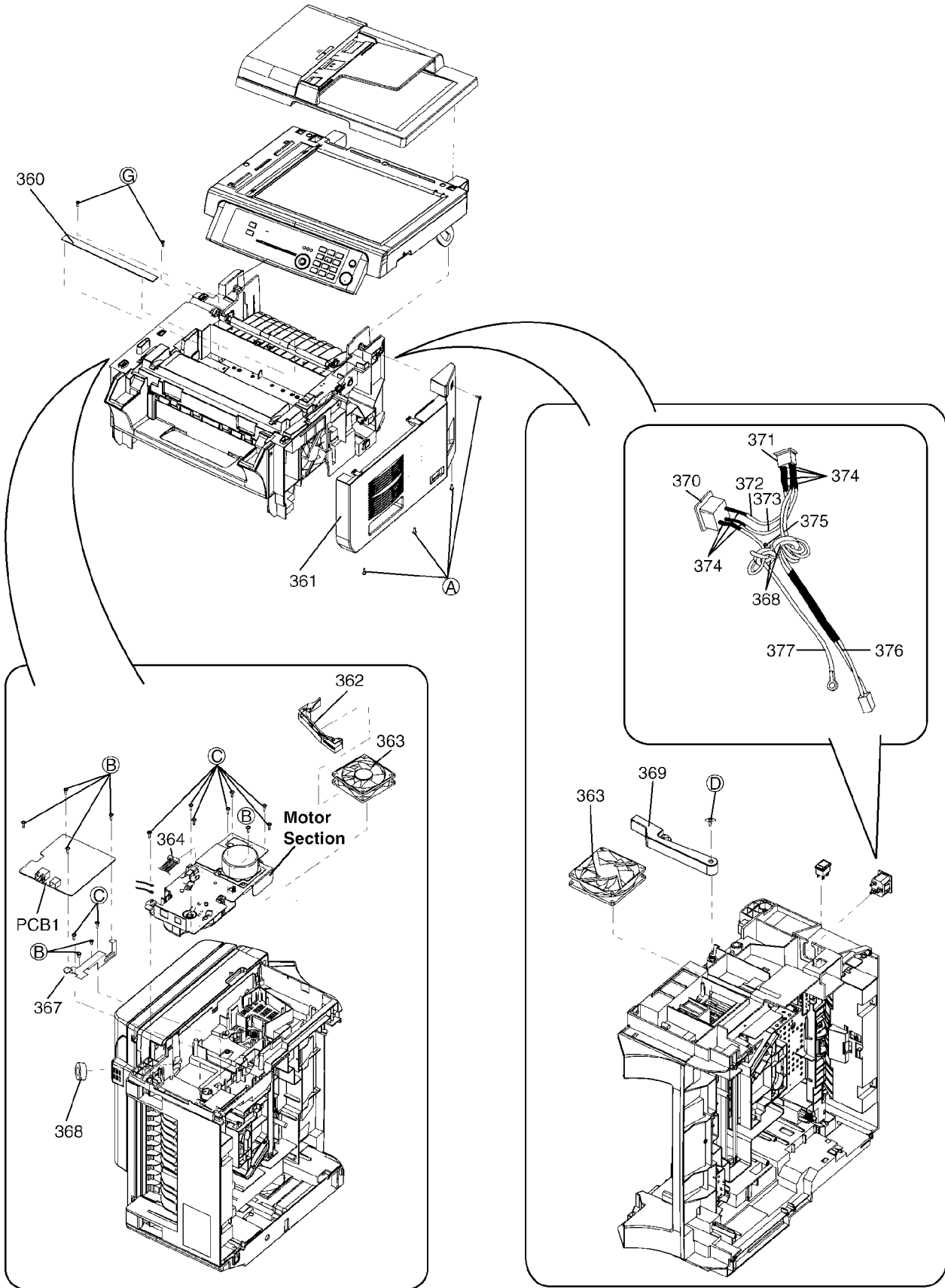

This pictured model is KX-MB2010.

18.1.11. Motor Section

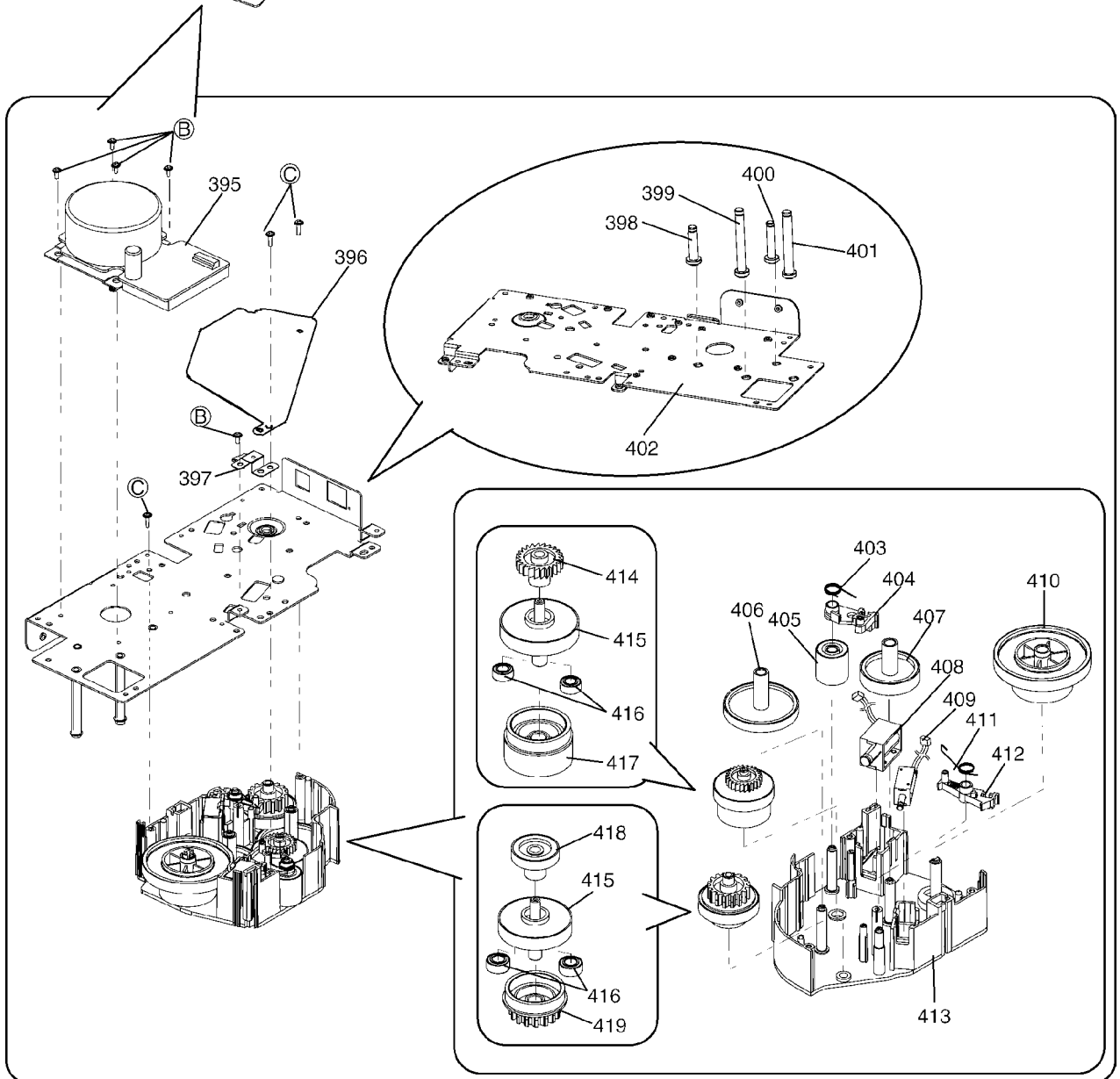
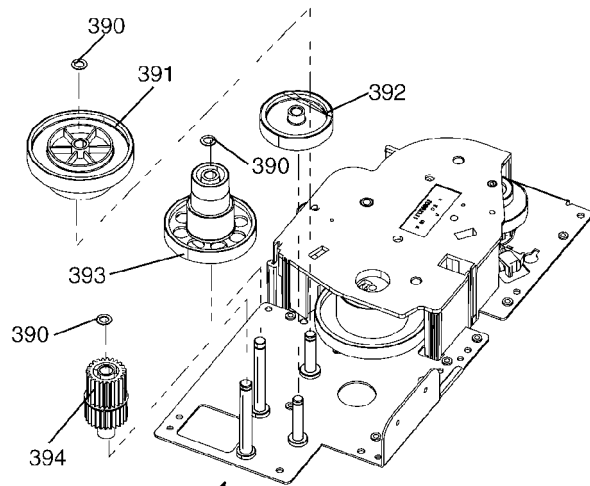

18.1.12. Bottom Cabinet Section (2)

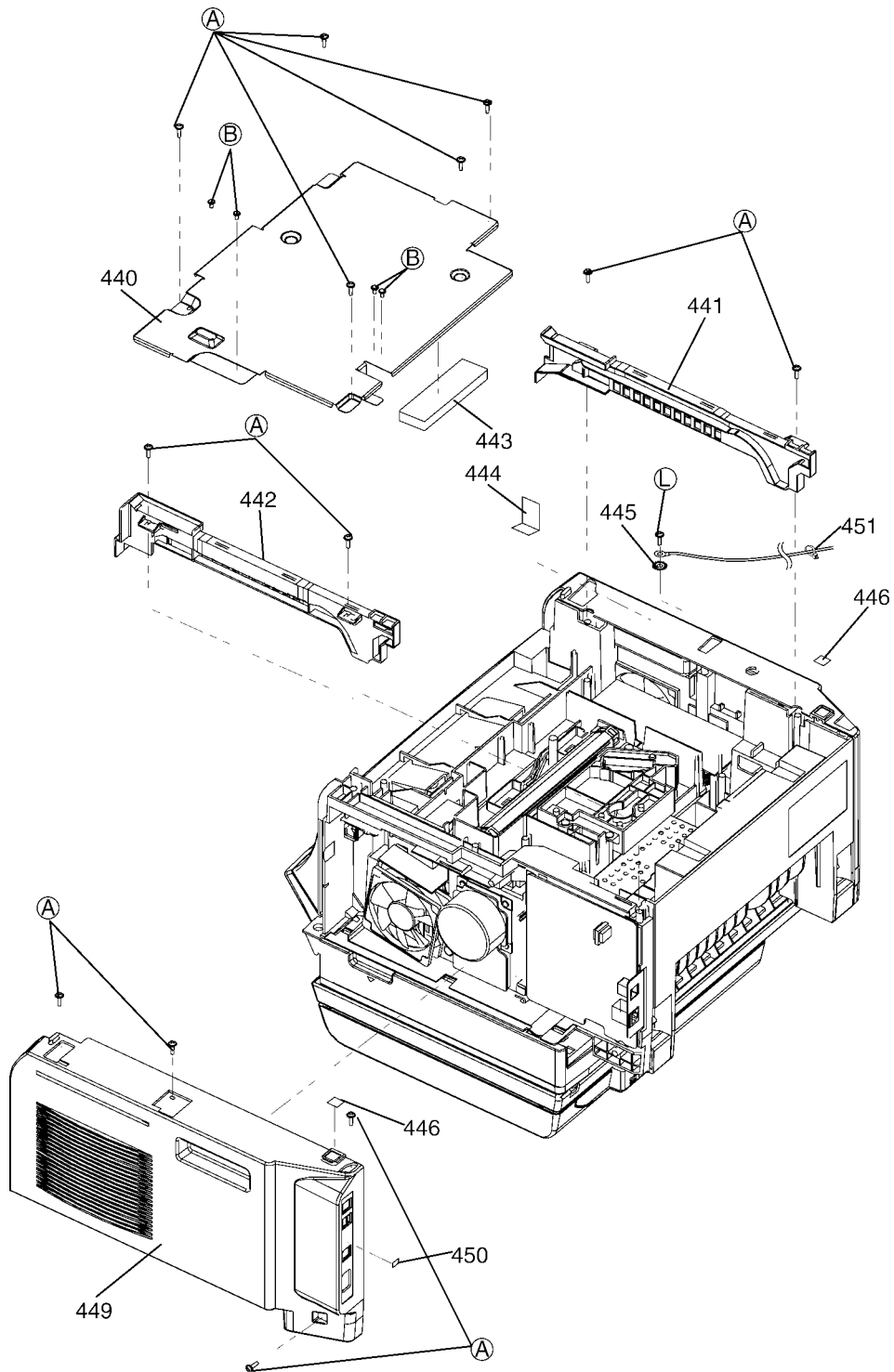



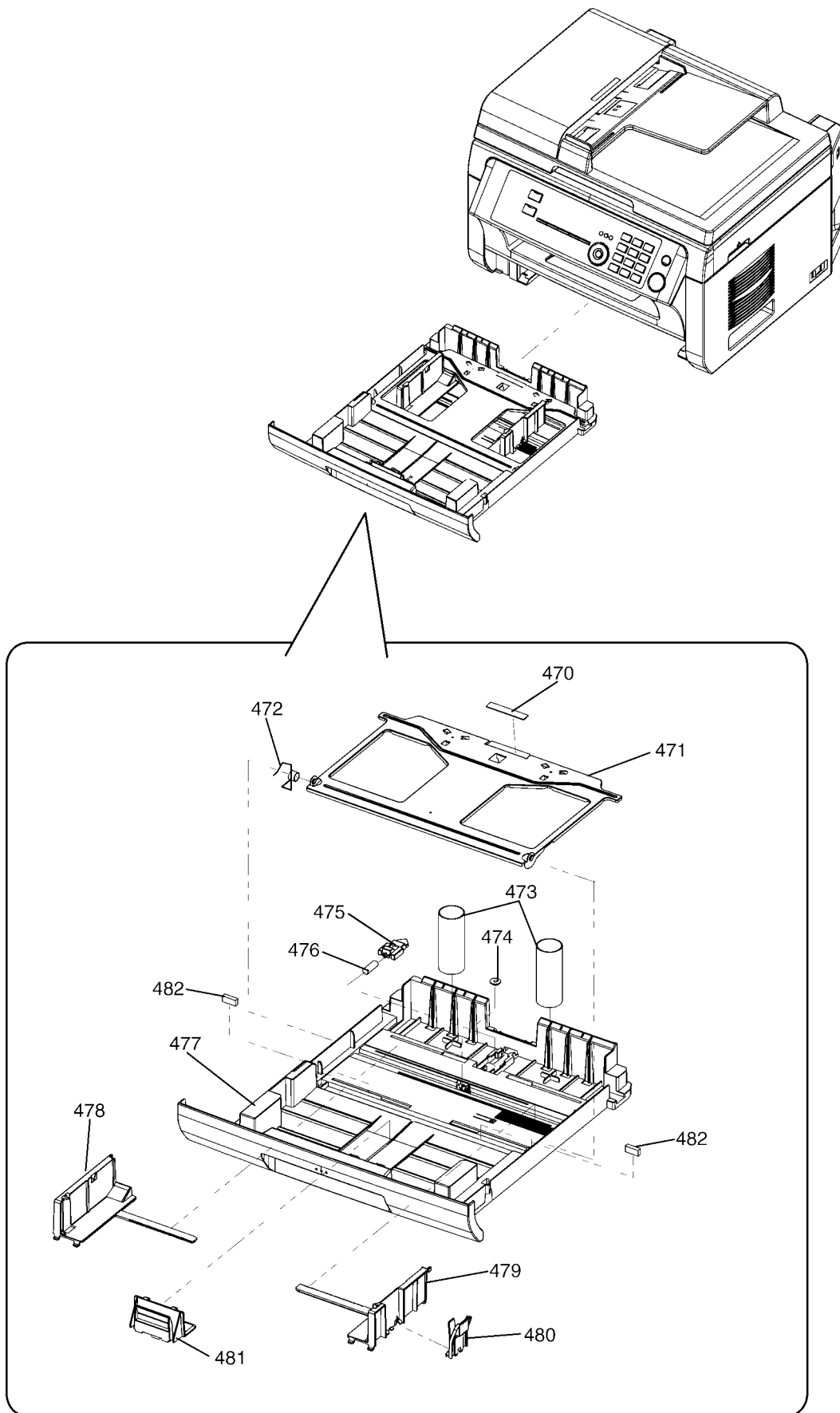





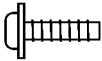

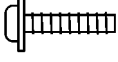
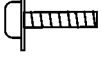
18.1.13. Output Tray Section

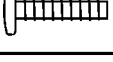

This pictured model is KX-MB2010.

18.1.14. Actual Size of Screws and Washer

		Illustration
Ⓐ	XTW3+10PFJ7	
Ⓑ	XTW3+6LFJ7	
Ⓒ	XTW3+12PFJ7	
Ⓓ	XTW3+W10PFJ	
Ⓔ	XYC3+FF8FJ	
Ⓕ	XYC3+CF5FJ	
Ⓖ	XTB3+10GFJ	
Ⓗ	XTB3+12JFJ	
Ⓘ	XTW3+20PFJ	
Ⓙ	XTW3+5LFJK7	
Ⓚ	XYN3+C6FJ	
Ⓛ	XSB4+6FJ	

18.1.15. Accessories and Packing Materials (KX-MB2010)

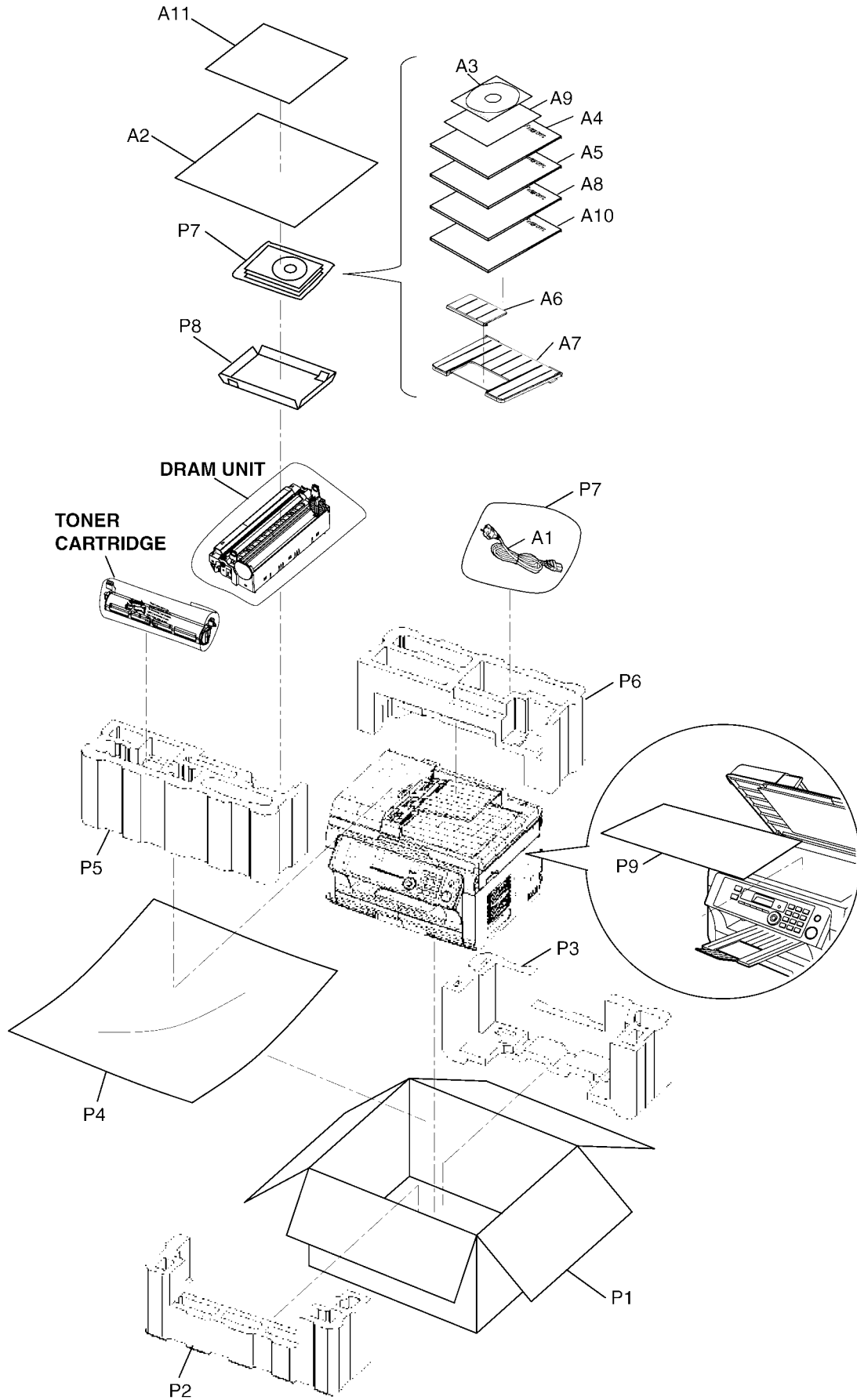

18.1.16. Accessories and Packing Materials (KX-MB2000)

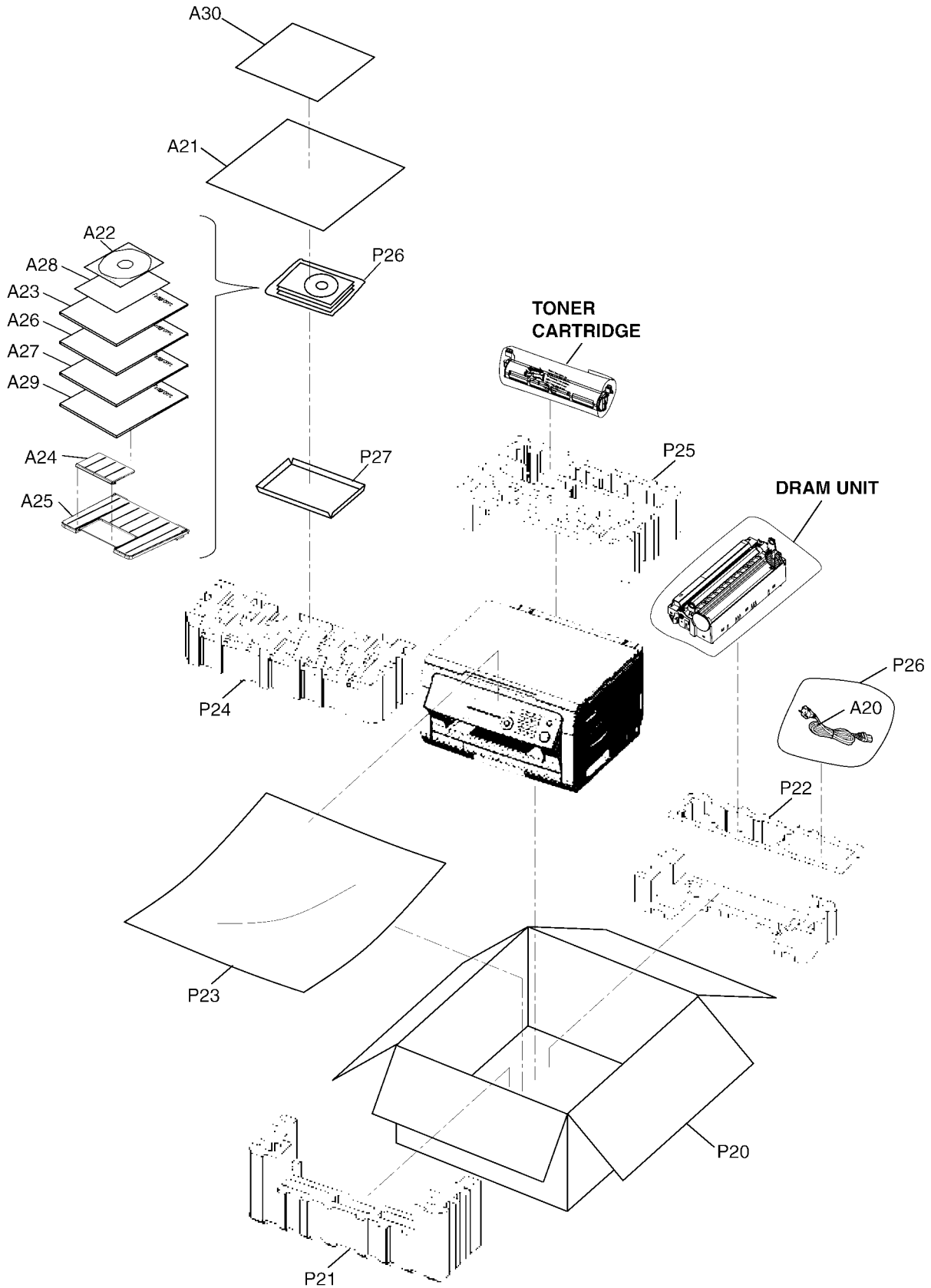

18.2. Replacement Parts List

RTL (Retention Time Limited)

Notes:

- The "RTL" marking indicates that its Retention Time is Limited.

When production is discontinued, this item will continue to be available only for a specific period of time. This period of time depends on the type of item, and the local laws governing parts and product retention.

At the end of this period, the item will no longer be available.

- Important safety notice

Components identified by Δ mark have special characteristics important for safety. When replacing any of these components, use only manufacture's specified parts.

- The S mark means the part is one of some identical parts. For that reason, it may be different from the installed part.
- ISO code (Example : ABS-HB) of the remarks column shows quality of the material and a flame resisting grade about plastics.

- RESISTORS & CAPACITORS

Unless otherwise specified;

All resistors are in ohms (Ω) k=1000 Ω , M=1000k Ω

All capacitors are in MICRO FARADS (μ F) P= μ μ F

*Type & Wattage of Resistor

Type

ERC:Solid	ERX: Metal Film	PQ4R: Carbon
ERD: Carbon	ERG: Metal Oxide	ERS: Fusible Resistor
PQRD: Carbon	ER0: Metal Film	ERF: Cement Resistor

Wattage

10,16:1/8W	14,25:1/4W	12:1/2W	1:1W	2:2W	3:3W
------------	------------	---------	------	------	------

*Type & Voltage of Capacitor

Type

ECFD: Semi-Conductor	ECCD,ECKD,ECBT,PQCBC: Ceramic
ECQS: Styrol	ECQE,ECQV,ECQG: Polyester
PQCUV: Chip	ECEA,ECSZ: Electrolytic
ECQMS: Mica	ECQP: Polypropylene

Voltage

ECQ Type	ECQG ECQV Type	ECSZ Type	Others		
1H:50V	05:50V	0F:3.15V	0J :6.3V	1V :35V	
2A:100V	1:100V	1A:10V	1A :10V	50,1H:50V	
2E:250V	2:200V	1V:35V	1C :16V	1J :63V	
2H:500V		0J:6.3V	1E,25:25V	2A :100V	

18.2.1. Cabinet and Electrical Parts

18.2.1.1. Operation Panel Section

Safety	Ref. No.	Part No.	Part Name & Description	Remarks
	1	PNBC1289Z1	PUSH BUTTON, STOP	ABS-HB
	2	PNBC1288Z1	PUSH BUTTON, START	ABS-HB
	3	PNBX1065W1	PUSH BUTTON, 12KEY	ABS-HB
	4	PNBC1295Z1	PUSH BUTTON, MENU	ABS-HB
	5	PNBC1286W1	PUSH BUTTON, SET	ABS-HB
	6	PNBC1285Y1	PUSH BUTTON, CURSOR	ABS-HB
	7	PNHR1200Z	CASE/COVER	ABS-HB
	8	PNBX1069Y1	PUSH BUTTON, 5KEY	ABS-HB
	9	NOT USED		
	10	PNHR1203Y	CASE/COVER	ABS-HB
	11	PNBX1070Y1	PUSH BUTTON, FAX/COPY	ABS-HB
	12	NOT USED		
	13	NOT USED		
	14	PNGP1095E1	PANEL (for KX-MB2000HXB)	PC-HB

Safety	Ref. No.	Part No.	Part Name & Description	Remarks
	14	PNGP1095W1	PANEL (for KX-MB2010HXB)	PC-HB
	15	PNGX1017Y1	ORNAMENT	PS-HB
	16	PNGG1064E1	GRILLE	PS-HB

18.2.1.2. ADF Section (KX-MB2010)

Safety	Ref. No.	Part No.	Part Name & Description	Remarks
	30	PFKV1167Z2	COVER	PS-HB
	31	PFKR1110Z2	GUIDE	ABS-HB
	32	PFHX2126Z	PLASTIC PARTS	
	33	PFHG1282Z	RUBBER PARTS	
	34	PFDE1307Z	GUIDE	ABS-HB
	35	PFHG1284Z	RUBBER PARTS	
	36	PFUS1620Z	COIL SPRING	
	37	PFKR1111Z2	GUIDE	ABS-HB
	38	PFKE1084Y2	TRAY	PS-HB
	39	PFHX2130Y	PLASTIC PARTS	
	40	PFUS1918Z	COIL SPRING	
	41	PFDG1015Y	GEAR	POM-HB
	42	XUC2FJP	RETAINING RING	
	43	PFDG1559Z	GEAR	POM-HB
	44	PQUS10038Z	COIL SPRING	
	45	PFDJ1044Z	SPACER	
	46	PFDR1103X	ROLLER	
	47	PNJS041010Z	CONNECTOR	
	48	PFDE1306Z	LEVER	POM-HB
	49	PFHX1937Z	CASE/COVER	
	50	PFUS1824Y	COIL SPRING	
	51	PFDE1308Y	LEVER	POM-HB
	52	PFUS1629Z	TORSION SPRING	
	53	PFDR1062Z	ROLLER	
	54	PFDG1415Y	GEAR	POM-HB
	55	PFDJ1116Y	SPACER	POM-HB
	56	PFDR1104Y	ROLLER	
	57	PFDJ1116Z	SPACER	POM-HB
	58	PFHE1298Y	METAL PARTS	
	59	PFUG1049Y	GUIDE	PS-HB
	60	PQDR9685Y	ROLLER	
	61	PFDF1190Z	SHAFT	
	62	PFUS1822Z	COIL SPRING	
	63	PFDE1247X	LEVER	POM-HB
	64	PFDR1065Z	ROLLER	
	65	PFDG1413Z	GEAR	POM-HB
	66	PFDG1417Z	GEAR	POM-HB
	67	PFDG1416Z	GEAR	POM-HB
	68	PFDJ1044Z	SPACER	
	69	PFUS1826Z	COIL SPRING	
	70	PFDE1244Z	LEVER	POM-HB
	71	PFHR1479Z	GUIDE	POM-HB
	72	PFDR1064Z	ROLLER	
	73	PFDF1095Z	SHAFT	
	74	PNDF1029Z	SHAFT	
	75	PFUS1325Z	COIL SPRING	
	76	PFDG1558Z	GEAR	POM-HB
	77	PNDF1034Z	SHAFT	
	78	XUC3FJP	RETAINING RING	
	79	PFKV1166Z2	COVER	PS-HB
	80	PFUE1048Z	FRAME	PS-HB
	81	PFUS1825Z	TORSION SPRING	
	82	PFDF1191Z	SHAFT	
	83	PFDR1073Z	ROLLER	POM-HB
	84	PFHR1710W	CAM	POM-HB
	85	PFHR1290X	CHASSIS	POM-HB
	86	PFUS1350Z	COIL SPRING	
	87	PFHR1292Z	PLASTIC PARTS	POM-HB
	88	PFHR1289X	CHASSIS	POM-HB
	89	PFUS1621Z	BAR SPRING	
	90	PFDR1066Z	ROLLER	POM-HB
	91	PFKM1229V2	CABINET BODY	PS-HB
	92	NOT USED		
	93	PNQT1648Z	LABEL, LIST TO OPEN	

Safety	Ref. No.	Part No.	Part Name & Description	Remarks
	94	PNQT1647Z	LABEL, FACE UP	
	95	PQHR945Z	BAND	
	96	PFUS1566Z	COIL SPRING	

18.2.1.3. Flatbed Section (KX-MB2000)

Safety	Ref. No.	Part No.	Part Name & Description	Remarks
	100	PFUE1048Z	FRAME	
	101	PFHR1713Y	HINGE-STAY	
	102	PNKK1034X1	DOOR-LID	PS-HB
	103	PFUS1566Z	COIL SPRING	

18.2.1.4. ADF Gear Section (KX-MB2010)

Safety	Ref. No.	Part No.	Part Name & Description	Remarks
	110	L6HAYYR0015	DC MOTOR	
	111	PFDW1001Z	LEAD WIRE	
	112	PFMH1259Z	ANGLE	
	113	PFDG1554Z	GEAR	
	114	PFDG1557Z	GEAR	
	115	PFDG1552Z	GEAR	
	116	PFDG1555Z	GEAR	
	117	PFDG1556Z	GEAR	
	118	PFDG1553Z	GEAR	
	119	PFUA1096Y	CHASSIS	

18.2.1.5. TOP Cover Section

Safety	Ref. No.	Part No.	Part Name & Description	Remarks
	130	PFDE1303X	SPACER	
	131	N2GAYY000002	IMAGE SENSOR	
	132	PFHX2126Z	PLASTIC PARTS	
	133	J0KE00000114	INSULATOR	
	134	PNJS131001Z	CONNECTOR	
	135	PFJS04M74Z	LEAD WIRE	
	136	PFUS1642Y	COIL SPRING	
	137	PFUS1344Z	COIL SPRING	
	138	PFDC1005X	GUIDE	
	139	PFJE1068Z	LEAD WIRE	
	140	PNDF1028Z	SHAFT	
	141	PFDV1005Y	ROUND BELT	
	142	PFUS1817Z	COIL SPRING	
	143	PFHX2134Z	PLASTIC PARTS	
	144	PFHE1319Z	PLASTIC PARTS	
	145	PFUS1819Z	TORSION SPRING	
	146	WLL20YG18M3M	LEAD WIRE	
	147	PNDE1023Z1	LEVER	POM-HB
	148	PNUS1101Z	COIL SPRING	
	149	PNJS031003Z	CONNECTOR	
	150	PNJS081030Z	CONNECTOR	
	151	PFNPD031054C	WASHER	
	152	PFDE1170Z	PULLEY	
	153	PFDE1168Z	PULLEY	
	154	PFDG1551Y	GEAR	
	155	PFMH1258Z	PLATE	
	156	L6HAYYR0013	DC MOTOR	
	157	PFDE1169Z	PULLEY	
	158	PFMH1257Z	PLATE	
	159	PFMH1159Z	METAL PARTS	
	160	PFDJ1042Z	SPACER	
	161	PFDS1032Z	ROLLER	
	162	PFDG1294Z	GEAR	
	163	PFUS1269Y	COIL SPRING	
	164	PNHG1095Z	RUBBER PARTS	
	165	PNDE1022Y1	ARM	PS-HB
	166	PNUS1100Y	COIL SPRING	
	167	PNHS1182Z	FELT PARTS	
	168	PNKV1059Z1	COVER	PS-HB

Safety	Ref. No.	Part No.	Part Name & Description	Remarks
	169	PNKM1110Y1	CABINET BODY	PS-HB
	170	PF0G1016Z	GLASS/TRANSPARENT PLATE	
	171	PF0G1017Z	GLASS/TRANSPARENT PLATE	
	172	PFMH1256Z	ANGLE	
	173	PFHX1796Z	PLASTIC PARTS	
	174	PFUS1820Z	TORSION SPRING	
	175	PFKF1205Y3	CABINET COVER	PS-HB
	176	PNZXB2030RUB	SCANNER GLASS ASS'Y	
	177	ZT2512-08	TAPE	

18.2.1.6. Main Cabinet Section

Safety	Ref. No.	Part No.	Part Name & Description	Remarks
	190	PNQT1720Z	LABEL, CAUTION	
	191	PFSE1054Z	ANGLE	
	192	PNUE1011Y	AIR DACT	ABS-HB
	193	PFJV1013Z	METAL PARTS	
	194	PFDG1420Z	GEAR	
	195	PFDJ1044Z	SPACER	
	196	PNDN1005Z	ROLLER	
	197	PFDJ1086X	SPACER	
	198	PFUS1613Z	COIL SPRING	
	199	PNDF1020Z	SHAFT	
	200	PFDJ1086Z	SPACER	
	201	PNKE1046Z1	COVER	PS-HB
	202	PNKE1047Z1	COVER	PS-HB
	203	PNKM1109Z1	CABINET BODY	PS-V0
	204	PFDJ1085Z	SPACER	
	205	PFQT2937Y	LABEL, MANUAL	
	206	PFKR1079Z2	GUIDE	
	207	PFKR1080Z2	GUIDE	
	208	PFKE1083Z2	PLASTIC PARTS	
	209	PFDG1015Y	GEAR	
	210	PNKK1037Y1	DOOR-LID	PS-HB
	211	PFDN1091Y	ROLLER	
	212	PFUS1812Z	COIL SPRING	
	213	PFDE1299Z	ROLLER	
	214	PFDG1550Z	GEAR	
	215	XUC2FJP	RETAINING RING	
	216	PNGT4555Z-M	NAME PLATE AL (for KX-MB2000HXB)	
	216	PNGT4633Z-M	NAME PLATE AL (for KX-MB2010HXB)	
	217	PNQT1734Z	LABEL, CAUTION DAMPER	
	218	PFHX1884Z	MAGNETIC SHIELD	
	219	PFDJ1085X	SPACER	
	220	PFQT1987Y	LABEL, CAUTION	

18.2.1.7. Fuser Section

Safety	Ref. No.	Part No.	Part Name & Description	Remarks
⚠	230	A4DYYY000004	COIL HEATER	
	231	PNDJ1012Z	SPACER	Plyamideimide-V0
	232	PNDS1010Y	ROLLER	A5052+PTFE
	233	PFDJ1114Z	SPACER	PPS-V0
	234	PFDG1421Z	GEAR	PPS-V0
	235	PNJT1036Z	TERMINAL-TERMINAL PLATE	
⚠	236	K0BDB0000073	THERMOSTAT	
	237	PNJT1037Z	TERMINAL-TERMINAL PLATE	
	238	PFMH1085Z	METAL PARTS	
	239	PFJT1032Z	TERMINAL-TERMINAL PLATE	
	240	PNHR1173Z	PLASTIC PARTS	PPS-V0
	241	PFUS1640Z	COIL SPRING	
	242	PNDRI021Y	ROLLER	
	243	PFDG1422Z	GEAR	Polyamide-V0
	244	XUC2FJP	RETAINING RING	
	245	PFDG1423Z	GEAR	POM-HB

Safety	Ref. No.	Part No.	Part Name & Description	Remarks
	246	PNDS1011Z	ROLLER	
	247	PFHR1705Z	ARM	PBT+ABS -GF30- V0
	248	PFDJ1113Z	SPACER	Poly- ether- imide- V0
	249	PFUS1426Z	COIL SPRING	
	250	PFHR1495Z	LEVER	PBT+GF3 0-V0
	251	PFDR1069Z	ROLLER	POM-HB
	252	PFUS1568Z	BAR SPRING	
	253	PFUA1094Y	CHASSIS	PBT+ABS GF30%- V0
	254	PFHR1496Z	LEVER	PBT+GF3 0-V0
	255	PFJS04M73Z	LEAD WIRE	
	256	L2AA0000106	THERMISTOR	
	257	PNUA1016X	CHASSIS	PBT+ABS -GF30- V0
	258	PFUS1686Z	TORSION SPRING	
	259	PFDE1310Z	LEVER	
	260	PNWEMB2030RU	FUSER UNIT	

18.2.1.8. Bottom Cabinet Section (1)

Safety	Ref. No.	Part No.	Part Name & Description	Remarks
	280	PNUS1092Y	LEAF SPRING	
	281	PFOM1008Z	MIRROR	
△	282	LPA1605K	LASER	
	283	PNJS051014Z	CONNECTOR	
	284	PNJS071017Z	CONNECTOR	
	285	PNJS081023Z	CONNECTOR	
	286	PNJS101002Z	CONNECTOR	
	287	PNQT1506Z	LABEL, LASER CAUTION	
	288	PFUS1592Z	TORSION SPRING	
	289	PNUE1012Z	KEYLOCK	PS-HB
	290	PFUS1811Z	COIL SPRING	
	291	PNVW1010Z	LEAD WIRE	
	292	PNVW1011Z	LEAD WIRE	
	293	PFUS1612Z	COIL SPRING	
	294	PNJS081031Z	CONNECTOR	
△	295	PFJS02M95Z	LEAD WIRE	
	296	PFMH1255Z	CASE/COVER	
	297	PFJS05M76Z	LEAD WIRE	
	298	PFUV1111Z	COVER	
	299	PFJS04M72Z	LEAD WIRE	
	300	PFDE1252Z	LEVER	
	301	PFUE1044Z	CHASSIS	
	302	PFUS1809Z	TORSION SPRING	
	303	PFUS1916Z	TORSION SPRING	
	304	PFUE1045Z	LEVER	
	305	PFUS1805Z	BAR SPRING	
	306	PFUS1806Z	BAR SPRING	
	307	PFUS1807Z	BAR SPRING	
	308	PFUS1808Z	BAR SPRING	
	309	PNDF1022Z	SHAFT	
	310	XPL15A10WVW2	COIL SPRING	
	311	PNUS1114Z	TORSION SPRING	
	312	PFDG1418Z	GEAR	
	313	PNHX1252Y	PLASTIC PARTS	
	314	PFDE1300Z	LEVER	
	315	PFDJ1084X	SPACER	
	316	PNUG1018Z	GUIDE	PS-V0
	317	PNDR1019Z	ROLLER	POM-HB
	318	PFDJ1084Z	SPACER	
	319	PNHR1236Z	SPACER	ABS-HB
	320	PNDR1018Z1	ROLLER	EPDM

18.2.1.9. Separation (DFP) Roller Section

Safety	Ref. No.	Part No.	Part Name & Description	Remarks
	330	PNHR1235Z	PLASTIC PARTS	ABS-HB
	331	PFNPD041065C	SPACER	
	332	PNUS1104Z	COIL SPRING	
	333	PFUS1923Z	COIL SPRING	
	334	PNDF1027Z	SHAFT	
	335	PNDR1020Z	ROLLER	POM-HB
	336	PFHR1538Z	CABINET ACCESSORY	
	337	PNUS1102Z	COIL SPRING	
	338	PNHG1088Z	RUBBER PARTS	
	339	PNUG1017X	GUIDE	PS-HB
	340	PNDR1014Z	ROLLER	
	341	PFHR1795Z	PLASTIC PARTS	
	342	PFDX1089Z	DRUM	
	343	PFDF1197Y	SHAFT	
	344	XPJ2A8VWM2	KEY-PIN	
	345	PNHR1234Y	CHASSIS	ABS-HB
	346	PNHX1224Z	PLASTIC PARTS	

18.2.1.10. Side Cabinet Section

Safety	Ref. No.	Part No.	Part Name & Description	Remarks
	360	PF0G1015Z	GLASS/TRANSPARENT PLATE	
	361	PNKV1061Z1	COVER	PS-V0
	362	PNHR1257Z	AIR DACT	
	363	L6FAYYYK0001	DC MOTOR	
	364	PNJS081024Z	CONNECTOR	
	365	NOT USED		
	366	NOT USED		
	367	PNMH1068Z	METAL PARTS	
	368	JOKE00000114	INSULATOR	
	369	PNDE1021Z1	LEVER	ABS-HB
△	370	K2AH3G000011	JACK/SOCKET	
△	371	KOAALE000029	SEESAW SWITCH	
△	372	PNWLXC12HHXX	LEAD WIRE	
△	373	PNWLXA13HHXX	LEAD WIRE	
	374	PQMX10010Z	CASE/COVER	
	375	PQHR945Z	BAND	
△	376	PNJS021038Z	CONNECTOR	
△	377	PNVW1012Z	LEAD WIRE	

18.2.1.11. Motor Section

Safety	Ref. No.	Part No.	Part Name & Description	Remarks
	390	PFNPD052080	SPACER	
	391	PFDG1544Y	GEAR	
	392	PFDG1548Z	GEAR	
	393	PFDG1543Z	GEAR	
	394	PFDG1549Z	GEAR	
	395	L6CCYYK0006	DC MOTOR	
	396	PNHX1255Z	PLASTIC PARTS	
	397	PNMH1067Z	METAL PARTS	
	398	PNDF1024Z	SHAFT	
	399	PNDF1023Z	SHAFT	
	400	PNDF1025Z	SHAFT	
	401	PNDF1026Z	SHAFT	
	402	PNMD1027Z	FRAME	
	403	PFUS1803Z	TORSION SPRING	
	404	PFDE1298Y	LEVER	
	405	PFDG1391Z	GEAR	
	406	PFDG1546Z	GEAR	
	407	PFDG1390Z	GEAR	
	408	L9AAAYB0001	ERECTROMAGNETIC COIL	
	409	L9AAAYB0006	ERECTROMAGNETIC COIL	
	410	PFDG1545Y	GEAR	
	411	PNUS1014Z	TORSION SPRING	
	412	PFDE1297X	LEVER	

Safety	Ref. No.	Part No.	Part Name & Description	Remarks
	413	PFUA1092Z	CHASSIS	
	414	PFDG1547Z	GEAR	
	415	PFDG1402Z	GEAR	
	416	PFDG1403Z	GEAR	
	417	PFDG1404Z	GEAR	
	418	PFDG1401Z	GEAR	
	419	PFDG1407Z	GEAR	

18.2.1.12. Bottom Cabinet Section (2)

Safety	Ref. No.	Part No.	Part Name & Description	Remarks
	440	PFMD1112Z	PLATE	
	441	PNUG1016Z	GUIDE	PS-HB
	442	PNUG1015Z	GUIDE	PS-HB
	443	PNHS1171Z	FELT PARTS	
	444	PNHX1269Y	PLASTIC PARTS	
	445	XWC4BFJ	WASHER	
	446	PFHA1001Z	RUBBER PARTS	
	447	NOT USED		
	448	NOT USED		
	449	PNKV1060Z1	COVER	PS-V0
	450	PFQT3054Z	LABEL, USB	
	451	PQHR945Z	BAND	

18.2.1.13. Output Tray Section

Safety	Ref. No.	Part No.	Part Name & Description	Remarks
	470	PFHG1245Z	RUBBER PARTS	
	471	PNMD1022Z	CHASSIS	
	472	PFUS1814Z	TORSION SPRING	
	473	PNUS1103Z	COIL SPRING	
	474	PFDG1015Y	GEAR	
	475	PFHR1491Z	LEVER	
	476	PFUS1608Z	COIL SPRING	
	477	PNKS1007Z1	TRAY	PS-HB
	478	PFKR1108Y	LEVER	
	479	PFKR1109Y	LEVER	
	480	PFHR1707Z	LEVER	
	481	PFKR1085Y	RACK	
	482	PNHS1174Z	FELT PARTS	

18.2.1.14. Screws

Safety	Ref. No.	Part No.	Part Name & Description	Remarks
	A	XTW3+10PFJ7	TAPPING SCREW, STEEL	
	B	XTW3+6LFJ7	TAPPING SCREW, STEEL	
	C	XTW3+12PFJ7	TAPPING SCREW, STEEL	
	D	XTW3+W10PFJ	TAPPING SCREW, STEEL	
	E	XYC3+FF8FJ	SCREW WITH WASHER, STEEL	
	F	XYC3+CF5FJ	SCREW WITH WASHER, STEEL	
	G	XTB3+10GFJ	TAPPING SCREW, STEEL	
	H	XTB3+12JFJ	TAPPING SCREW, STEEL	
	I	XTW3+20PFJ	TAPPING SCREW, STEEL	
	J	XTW3+5LFJK7	TAPPING SCREW, STEEL	
	K	XYN3+C6FJ	SCREW WITH WASHER, STEEL	
	L	XSB4+6FJ	SMALL SCREW, STEEL	

18.2.1.15. Accessories and Packing Materials (KX-MB2010)

Safety	Ref. No.	Part No.	Part Name & Description	Remarks
△	A1	PFJA03A010Z	POWER CORD	
	A2	PNQW1881Y	LEAFLET	

Safety	Ref. No.	Part No.	Part Name & Description	Remarks
	A3	PNJKMB2030Z	MEMORY PARTS	
	A4	PNQW2159Z	LEAFLET, IIG (Czech)	
	A5	PNQW2211Z	LEAFLET, IIG (Hungarian)	
	A6	PNKS1011Z1	TRAY	PS-HB
	A7	PNKS1010Z1	TRAY	PS-HB
	A8	PNQW2212Z	LEAFLET, IIG (Slovak)	
	A9	PNQW1315X	LEAFLET	
	A10	PNQX2616Z	INSTRUCTION BOOK (English)	
	A11	PNQW2143Z	LEAFLET	
	P1	PNPK2907Z-M	PACKING CASE	
	P2	PNPN1126Y	CUSHION	ABS-HB
	P3	PNPN1136Y	CUSHION	ABS-HB
	P4	PFPP1041Z	PROTECTION COVER	
	P5	PNPN1124Y	CUSHION	PC-HB
	P6	PNPN1125Y	CUSHION	ABS-HB
	P7	PFPP1052Z	PROTECTION COVER	
	P8	PFPP1355Z	CUSHION	
	P9	PFPH1046Y	PROTECTION COVER	

18.2.1.16. Accessories and Packing Materials (KX-MB2000)

Safety	Ref. No.	Part No.	Part Name & Description	Remarks
△	A20	PFJA03A010Z	POWER CORD	
	A21	PNQW1881Y	LEAFLET	
	A22	PNJKMB2030Z	MEMORY PARTS	
	A23	PNQW2159Z	LEAFLET, IIG (Czech)	
	A24	PNKS1011Z1	TRAY	PS-HB
	A25	PNKS1010Z1	TRAY	PS-HB
	A26	PNQW2211Z	LEAFLET, IIG (Hungarian)	
	A27	PNQW2212Z	LEAFLET, IIG (Slovak)	
	A28	PNQW1315X	LEAFLET	
	A29	PNQX2616Z	INSTRUCTION BOOK (English)	
	A30	PNQW2143Z	LEAFLET	
	P20	PNPK2906Z-M	PACKING CASE	ABS-HB
	P21	PNPN1133Y	CUSHION	ABS-HB
	P22	PNPN1135Y	CUSHION	ABS-HB
	P23	PFPP1041Z	PROTECTION COVER	
	P24	PNPN1132Y	CUSHION	ABS-HB
	P25	PNPN1134Y	CUSHION	ABS-HB
	P26	PFPP1052Z	PROTECTION COVER	
	P27	PNPD1121Z	CUSHION	

18.2.2. Main Board (KX-MB2000)

Safety	Ref. No.	Part No.	Part Name & Description	Remarks
	PCB1	PNWP1B2000HX	MAIN BOARD ASS'Y (RTL)	
			(ICs)	
	IC300	C1ZBZ0003801	IC	S
	IC301	C0EBE0000504	IC	
	IC303	C0CBAAA00035	IC	
	IC400	C3ABRY000039	IC	
	IC402	PNWI2000HX	IC (ROM)	
	IC501	C0DBGY00330	IC	
	IC502	C0GBY0000066	IC	
	IC503	C1DB00001173	IC	
	IC504	C0BBBA000044	IC	S
	IC750	C1CB00002566	IC	
	IC800	C0DBAGE00028	IC	
			(TRANSISTORS)	
	Q500	B1ABCF000103	TRANSISTOR (SI)	S
	Q501	UNR92ANJ0L	TRANSISTOR (SI)	
	Q502	UNR92ANJ0L	TRANSISTOR (SI)	
	Q503	UNR92ANJ0L	TRANSISTOR (SI)	
	Q504	UNR92ANJ0L	TRANSISTOR (SI)	
	Q505	UNR92ANJ0L	TRANSISTOR (SI)	

Safety	Ref. No.	Part No.	Part Name & Description	Remarks
	Q506	UNR92ANJ0L	TRANSISTOR (SI)	
	Q507	UNR921LJ0L	TRANSISTOR (SI)	S
	Q509	2SB1197KQ	TRANSISTOR (SI)	S
	Q510	B1CHND000004	TRANSISTOR (SI)	
	Q511	UNR92ANJ0L	TRANSISTOR (SI)	
	Q512	B1ABCF000103	TRANSISTOR (SI)	S
	Q514	2SD0874AS	TRANSISTOR (SI)	
	Q516	2SD0874AS	TRANSISTOR (SI)	
	Q517	2SD0874AS	TRANSISTOR (SI)	
	Q518	B1ADGE000004	TRANSISTOR (SI)	
	Q521	2SK3018	TRANSISTOR (SI)	S
	Q522	B1ABCF000103	TRANSISTOR (SI)	S
	Q523	B1ADGE000004	TRANSISTOR (SI)	
	Q524	UNR92ANJ0L	TRANSISTOR (SI)	
	Q525	UNR92ANJ0L	TRANSISTOR (SI)	
	Q526	UNR92ANJ0L	TRANSISTOR (SI)	
	Q527	UNR92A9J0L	TRANSISTOR (SI)	
	Q528	UNR92ANJ0L	TRANSISTOR (SI)	
	Q529	B1ADCF000161	TRANSISTOR (SI)	
	Q530	2SK3018	TRANSISTOR (SI)	S
	Q800	2SC4081R	TRANSISTOR (SI)	S
	Q801	UNR92A5J0L	TRANSISTOR (SI)	
	Q802	B1CHQD000001	TRANSISTOR (SI)	
	Q803	B1CHQD000001	TRANSISTOR (SI)	
	Q804	B1ABKD000001	TRANSISTOR (SI)	
	Q805	B1ABKD000001	TRANSISTOR (SI)	
	Q806	2SB1197KQ	TRANSISTOR (SI)	S
	Q807	2SB1197KQ	TRANSISTOR (SI)	S
			(DIODES)	
	D306	B0ZBZ0000146	DIODE (SI)	
	D308	B0BC5R000009	DIODE (SI)	
	D501	B0ACEL000004	DIODE (SI)	
	D503	B0ACEL000004	DIODE (SI)	
	D504	B0ACEL000004	DIODE (SI)	
	D800	B0JCPD000033	DIODE (SI)	
	D801	B0BC5R900006	DIODE (SI)	
	D803	B0JCPD000033	DIODE (SI)	
	D804	B0BC3R800009	DIODE (SI)	
	D805	B0BC01000014	DIODE (SI)	
	D806	B0BC01000014	DIODE (SI)	
	DA300	MA142WKTXX	DIODE (SI)	S
	DA500	MA142WKTXX	DIODE (SI)	S
	LED750	B3ABB0000331	DIODE (SI)	
			(BATTERY)	
	BAT300	CR-2354/GUFX	BATTERY	
			(CAPACITORS)	
	C300	ECUE1C104ZFQ	0.1	
	C301	ECUE1C104ZFQ	0.1	
	C304	ECJ0EB0J224K	0.22	S
	C305	ECJ0EB0J224K	0.22	S
	C306	ECJ0EB0J224K	0.22	S
	C308	ECJ0EB0J224K	0.22	S
	C310	ECUE1H220JJCQ	22p	
	C311	ECUE1H270JJCQ	27p	
	C312	ECUE1A104KBQ	0.1	
	C315	ECUE1H100DCQ	10p	
	C316	ECUE1H8R0DCQ	8	
	C317	ECUE1H270JJCQ	27p	
	C318	ECUE1H120JJCQ	12p	
	C319	ECUE0J105KBQ	1	
	C321	ECUE1C104ZFQ	0.1	
	C322	ECUE0J105KBQ	1	
	C325	ECUE1C104ZFQ	0.1	
	C326	ECUE1C103KBQ	0.01	
	C327	ECUE1C104ZFQ	0.1	
	C328	ECUE1C104ZFQ	0.1	
	C329	ECUE1C104ZFQ	0.1	
	C330	ECUE1C104ZFQ	0.1	
	C331	ECUE1C104ZFQ	0.1	
	C332	ECUE1C104ZFQ	0.1	
	C333	ECUE1C104ZFQ	0.1	
	C334	ECUE1C104ZFQ	0.1	
	C335	ECUE1C104ZFQ	0.1	

Safety	Ref. No.	Part No.	Part Name & Description	Remarks
	C336	ECUE1C104ZFQ	0.1	
	C337	ECUE1C104ZFQ	0.1	
	C338	ECUE1C104ZFQ	0.1	
	C339	ECUE1C104ZFQ	0.1	
	C351	ECUE1H101JJCQ	100p	
	C352	ECUE1C104ZFQ	0.1	
	C353	ECUE1C104ZFQ	0.1	
	C354	ECUE1C104ZFQ	0.1	
	C355	ECUE1C104ZFQ	0.1	
	C357	ECUE1C104ZFQ	0.1	
	C358	ECUE1C104ZFQ	0.1	
	C359	ECUE1C104ZFQ	0.1	
	C360	ECUE1C104ZFQ	0.1	
	C361	ECUE1C104ZFQ	0.1	
	C362	ECUE1C104ZFQ	0.1	
	C363	ECUE1C104ZFQ	0.1	
	C364	ECUE1C104ZFQ	0.1	
	C400	ECUE1C104ZFQ	0.1	
	C401	ECUE1C103KBQ	0.01	
	C402	ECUE1C104ZFQ	0.1	
	C403	ECUE1C104ZFQ	0.1	
	C404	ECUE1C104ZFQ	0.1	
	C405	ECUE1C103KBQ	0.01	
	C406	ECUE1C104ZFQ	0.1	
	C412	ECUE1C103KBQ	0.01	
	C413	ECUE1C104ZFQ	0.1	
	C414	ECUE1C104ZFQ	0.1	
	C419	ECUE1H101JJCQ	100p	
	C420	ECUE1H101JJCQ	100p	
	C421	ECUE1H101JJCQ	100p	
	C422	ECUE1H101JJCQ	100p	
	C423	ECUE1H101JJCQ	100p	
	C424	ECUE1H101JJCQ	100p	
	C425	ECUE1H101JJCQ	100p	
	C426	ECUE1H101JJCQ	100p	
	C427	ECUE1H101JJCQ	100p	
	C428	ECUE1H101JJCQ	100p	
	C429	ECUE1H101JJCQ	100p	
	C470	ECUE1H270JJCQ	27p	
	C471	ECUE1C104ZFQ	0.1	
	C501	ECUV1H104ZFFV	0.1	
	C502	ECUE0J105KBQ	1	
	C503	ECUV1H104ZFFV	0.1	
	C504	ECUE1C104ZFQ	0.1	
	C505	F2G1V2210014	220	
	C506	ECUE1H100DCQ	10p	
	C507	ECUE1H102KBQ	0.001	
	C508	ECJ0EB1A473K	0.047	S
	C509	ECUE1A104KBQ	0.1	
	C510	ECUE1A104KBQ	0.1	
	C511	ECUE1H102KBQ	0.001	
	C512	F1J0J1060006	10	
	C513	ECUV1A105ZFFV	1	
	C514	ECUE1H101JJCQ	100p	
	C515	F2G1V2210014	220	
	C516	ECUE1H102KBQ	0.001	
	C517	ECUE1H102KBQ	0.001	
	C518	ECUV1H104ZFFV	0.1	
	C520	ECUE1H102KBQ	0.001	
	C522	ECUE1H102KBQ	0.001	
	C524	F2G1V4700028	47	
	C525	ECUV1H104ZFFV	0.1	
	C526	ECUE1H102KBQ	0.001	
	C527	ECUE1H102KBQ	0.001	
	C528	ECUE1H102KBQ	0.001	
	C529	ECUE1H102KBQ	0.001	
	C530	F1J0J1060006	10	
	C531	F1J0J1060006	10	
	C533	ECUE1A104KBQ	0.1	
	C534	ECUE1A104KBQ	0.1	
	C536	ECUE1A104KBQ	0.1	
	C537	ECUE1A104KBQ	0.1	
	C538	F1J0J1060006	10	

Safety	Ref. No.	Part No.	Part Name & Description	Remarks
	C540	ECUE1A104KBQ	0.1	
	C542	ECUE1A104KBQ	0.1	
	C543	ECUE1A104KBQ	0.1	
	C544	ECUE1C103KBQ	0.01	
	C545	ECUE0J105KBQ	1	
	C546	ECUE1C103KBQ	0.01	
	C547	ECUE1H101JCQ	100p	
	C548	ECUE1H102KBQ	0.001	
	C549	F2G0J1010015	100	
	C550	F2G1C2200013	22	
	C551	ECUE1H102KBQ	0.001	
	C552	ECUE1C104ZFQ	0.1	
	C553	ECUE1H102KBQ	0.001	
	C554	ECUE1H102KBQ	0.001	
	C555	ECUE1C104ZFQ	0.1	
	C556	ECUE1H101JCQ	100p	
	C557	ECUE1H181JCQ	180p	
	C559	ECUE1H102KBQ	0.001	
	C563	ECUE1H102KBQ	0.001	
	C565	ECJ0EB1A473K	0.047	S
	C568	ECUE1H102KBQ	0.001	
	C569	ECJ0EB1A473K	0.047	S
	C571	ECUE0J105KBQ	1	
	C572	ECUE1C104ZFQ	0.1	
	C645	ECUE1C104ZFQ	0.1	
	C646	ECUE1C104ZFQ	0.1	
	C647	ECUE1C104ZFQ	0.1	
	C648	ECUE1C104ZFQ	0.1	
	C649	ECUE1C104ZFQ	0.1	
	C650	ECUE1C104ZFQ	0.1	
	C651	ECUE1C104ZFQ	0.1	
	C652	ECUE1C104ZFQ	0.1	
	C653	ECUE1C104ZFQ	0.1	
	C654	ECUE1C104ZFQ	0.1	
	C655	ECUE1C104ZFQ	0.1	
	C656	ECUE1C104ZFQ	0.1	
	C657	ECUE1C104ZFQ	0.1	
	C658	ECUE1C104ZFQ	0.1	
	C659	ECUE1C104ZFQ	0.1	
	C660	ECUE1C104ZFQ	0.1	
	C661	ECUE1C104ZFQ	0.1	
	C662	ECUE1C104ZFQ	0.1	
	C663	ECUE1C104ZFQ	0.1	
	C664	ECUE1C104ZFQ	0.1	
	C665	ECUE1C104ZFQ	0.1	
	C666	ECUE1C104ZFQ	0.1	
	C667	ECUE1C104ZFQ	0.1	
	C668	ECUE1C104ZFQ	0.1	
	C669	ECUE1C104ZFQ	0.1	
	C670	ECUE1C104ZFQ	0.1	
	C671	ECUV1H104ZV	0.1	
	C672	ECUV1H104ZV	0.1	
	C673	ECUV1H104ZV	0.1	
	C674	ECUE1C104ZFQ	0.1	
	C675	ECUE1C104ZFQ	0.1	
	C676	ECUE1C104ZFQ	0.1	
	C677	ECUE1C104ZFQ	0.1	
	C678	ECUE1C104ZFQ	0.1	
	C679	ECUE1C104ZFQ	0.1	
	C680	ECUE1C104ZFQ	0.1	
	C681	ECUE1C104ZFQ	0.1	
	C682	ECUE1C104ZFQ	0.1	
	C683	ECUE1C104ZFQ	0.1	
	C684	ECUE1C104ZFQ	0.1	
	C685	ECUE1C104ZFQ	0.1	
	C687	ECUE1C104ZFQ	0.1	
	C688	ECUE1C104ZFQ	0.1	
	C689	ECUE1C104ZFQ	0.1	
	C690	ECUE1C104ZFQ	0.1	
	C691	ECUE1C104ZFQ	0.1	
	C692	ECUE1C104ZFQ	0.1	
	C693	ECUE1C104ZFQ	0.1	
	C695	ECUE1C104ZFQ	0.1	

Safety	Ref. No.	Part No.	Part Name & Description	Remarks
	C696	ECUE1C104ZFQ	0.1	
	C697	ECUE1C104ZFQ	0.1	
	C698	ECUE1C104ZFQ	0.1	
	C699	ECUE1C104ZFQ	0.1	
	C750	ECUE1H101JCQ	100p	
	C751	ECUE1C104ZFQ	0.1	
	C752	F2G0J4700013	47	
	C753	ECUE1C104ZFQ	0.1	
	C754	ECUE1A104KBQ	0.1	
	C755	ECUE1A104KBQ	0.1	
	C756	ECUE1H100DCQ	10p	
	C757	ECUE1H150JCQ	15p	
	C758	ECUE1C104ZFQ	0.1	
	C759	F1J0J1060006	10	
	C760	ECUE1C103KBQ	0.01	
	C762	F2G0J4700013	47	
	C763	ECUE1H220JCQ	22p	
	C764	ECUE1H220JCQ	22p	
	C765	ECUE1H220JCQ	22p	
	C766	ECUE1H220JCQ	22p	
	C767	ECUE1A104KBQ	0.1	
	C768	ECUE1A104KBQ	0.1	
	C769	F1J0J1060006	10	
	C770	ECUE1H101JCQ	100p	
	C800	F2H0J1010009	100	
	C801	ECUV1H104ZV	0.1	
	C802	PQCUV1A105KB	1	
	C803	ECUV1H104ZV	0.1	
	C804	F1L1V1060002	35	
	C805	F1L1V1060002	35	
	C806	ECUV1H104ZV	0.1	
	C807	ECUV1H104ZV	0.1	
	C808	ECUV1H104ZV	0.1	
	C809	ECJ0EB1A473K	0.047	S
	C810	ECUV1H103KBV	0.01	
	C811	ECUV1A474KBV	0.47	
	C812	ECUV1H103KBV	0.01	
	C813	ECUV1A334KBV	0.33	
	C814	ECUE1A104KBQ	0.1	
	C817	F2H0J1010009	100	
	C818	PQCUV1A105KB	1	
	C819	PQCUV1C105ZF	1	S
	C820	PQCUV1C105ZF	1	S
			(CONNECTORS & JACKS)	
	CN300	K1FY104B0015	CONNECTOR, 8PIN	
	CN500	K1KA07A00257	CONNECTOR, 7PIN	
	CN501	K1KA05A00364	CONNECTOR, 5PIN	
	CN502	K1KA08AA0193	CONNECTOR, 8PIN	
	CN504	K1KA08A00498	CONNECTOR, 8PIN	
	CN505	K1KA08A00440	CONNECTOR, 8PIN	
	CN506	K1KA03AA0193	CONNECTOR, 3PIN	
	CN507	K1KA02AA0193	CONNECTOR, 2PIN	
	CN508	K1KA10A00412	CONNECTOR, 10PIN	
	CN509	K1KA04A00527	CONNECTOR, 4PIN	
	CN510	K1KA13A00130	CONNECTOR, 13PIN	
	CN511	K1KA08A00440	CONNECTOR, 8PIN	
	CN514	K1KA02AA0193	CONNECTOR, 2PIN	
	CN750	K2LCL1YB0012	JACK	
			(FUSE)	
	F800	K5H302Y00003	FUSE	
			(COILS)	
	L300	G1BYYYC00026	COIL	
	L502	PFVF2P221SG	COIL	S
	L800	G1C220MA0291	COIL	
	L801	G1C220MA0291	COIL	
			(IC FILTERS)	
	L344	J0JCC0000286	IC FILTER	
	L345	J0JCC0000286	IC FILTER	
	L346	J0JCC0000286	IC FILTER	
	L347	J0JCC0000286	IC FILTER	
	L364	J0JCC0000274	IC FILTER	
	L500	J0JCC0000277	IC FILTER	
	L501	J0JCC0000276	IC FILTER	

Safety	Ref. No.	Part No.	Part Name & Description	Remarks
	L503	J0JGC0000020	IC FILTER	
	L504	J0JGC0000020	IC FILTER	
	L750	J0JCC0000276	IC FILTER	
	L752	J0MAB0000185	IC FILTER	
	L753	J0MAB0000185	IC FILTER	
	FLT500	JOHAAB000021	IC FILTER	
			(RESISTORS)	
	R302	ERJ2RKF49R9	49.9	
	R303	ERJ2GEJ472X	4.7k	
	R304	ERJ2GEJ101	100	
	R305	ERJ2GEJ103	10k	
	R307	ERJ2GEJ470	47	
	R308	ERJ2GEJ470	47	
	R309	ERJ2GEJ470	47	
	R315	ERJ2GEJ103	10k	
	R316	ERJ2GEJ103	10k	
	R335	ERJ2GEJ472X	4.7k	
	R338	ERJ2GEJ103	10k	
	R339	ERJ2GEJ223	22k	
	R340	ECUE1H220JCQ	22p	
	R348	ECUE1H220JCQ	22p	
	R349	ERJ2GEJ103	10k	
	R350	ERJ2GEJ103	10k	
	R351	ERJ2GEJ103	10k	
	R352	ERJ2GEJ103	10k	
	R353	ERJ2GEJ103	10k	
	R354	ERJ2GEJ103	10k	
	R355	ERJ2GEJ103	10k	
	R361	ERJ2GEJ103	10k	
	R363	ERJ2GEJ103	10k	
	R365	ERJ2GEJ103	10k	
	R367	ERJ2GEJ470	47	
	R368	ERJ2GEJ470	47	
	R369	ERJ2GEJ470	47	
	R372	ERJ2GEJ103	10k	
	R373	ERJ2GEJ103	10k	
	R375	ERJ2GEJ221	220	
	R376	ERJ2RKF6981	6.98k	
	R378	ERJ2GEJ102	1k	
	R380	ERJ2GEJ1R0	1	
	R381	ERJ2GEJ1R0	1	
	R382	ERJ2GEJ1R0	1	
	R384	ERJ2GEJ101	100	
	R385	ERJ2GEJ1R0	1	
	R386	ERJ2GEJ221	220	
	R387	ERJ2GEJ105X	1M	
	R388	ERJ2GEJ184	180k	
	R389	ERJ2GEJ102	1k	
	R391	ERJ2GEJ103	10k	
	R399	ERJ2GEJ103	10k	
	R400	ERJ2GEJ470	47	
	R401	ERJ2GEJ680	68	
	R402	ERJ2GEJ470	47	
	R403	ERJ2GEJ470	47	
	R404	ERJ2GEJ470	47	
	R405	ERJ2GEJ470	47	
	R406	ERJ2GEJ470	47	
	R407	ERJ2GEJ470	47	
	R408	ERJ2GEJ470	47	
	R409	ERJ2GEJ680	68	
	R410	ERJ2GEJ680	68	
	R449	ERJ2GEJ103	10k	
	R501	ERJ2GEJ101	100	
	R502	ERJ2GEJ101	100	
	R503	ERJ2RKF6201	6.2k	
	R504	ERJ2GEJ473	47k	
	R505	ERJ2RKF1503	150k	
	R506	ERJ2GEJ223	22k	
	R507	ERJ2RKF2202	22k	
	R508	ERJ2GEJ102	1k	
	R509	ERJ2GEJ102	1k	
	R510	ERJ2GEJ562X	5.6k	
	R511	ERJ2GEJ181	180	

Safety	Ref. No.	Part No.	Part Name & Description	Remarks
	R512	ERJ2GEJ563	56k	
	R513	ERJ2GEJ103	10k	
	R514	ERJ2RKF1503	150k	
	R515	ERJ2GEJ102	1k	
	R516	ERJ2GEJ823	82k	
	R517	ERJ2GEJ332	3.3k	
	R518	ERJ2GEJ472X	4.7k	
	R519	ERJ2GEJ472X	4.7k	
	R520	ERJ2GEJ102	1k	
	R521	ERJ2GEJ563	56k	
	R522	ERJ2GEJ103	10k	
	R523	ERJ2GEJ563	56k	
	R524	ERJ2GEJ472X	4.7k	
	R525	ERJ12YJ390	39	
	R526	ERJ2GEJ103	10k	
	R527	ERJ2GEJ562X	5.6k	
	R528	PQ4R10XJ332	3.3k	S
	R529	ERJ2GEJ103	10k	
	R530	ERJ2GEJ102	1k	
	R531	ERJ2GEJ562X	5.6k	
	R532	ERJ2GEJ103	10k	
	R533	ERJ2RKF1001	1k	
	R534	ERJ2GEJ473	47k	
	R535	ERJ2GEJ473	47k	
	R536	ERJ8RQFR39	0.39	
	R537	ERJ8RQFR39	0.39	
	R538	ERJ2GEJ102	1k	
	R539	ERJ2GEJ103	10k	
	R540	ERJ2GEJ221	220	
	R541	ERJ2GEJ122	1.2k	
	R542	ERJ2GEJ122	1.2k	
	R543	ERJ3GEYJ180	18	
	R544	ERJ2GEJ122	1.2k	
	R545	ERJ2GEJ123	12k	
	R546	ERJ2GEJ122	1.2k	
	R547	ERJ2GEJ471	470	
	R548	ERJ3GEYJ1R2	1.2	
	R549	ERJ3GEYJ330	33	
	R550	ERJ2GEJ122	1.2k	
	R551	ERJ2GEJ274	270k	
	R552	ERJ2GEJ102	1k	
	R553	ERJ2GEJ820	82	
	R554	ERJ2GEJ122	1.2k	
	R555	ERJ2GEJ472X	4.7k	
	R556	ERJ3GEYJ390	39	
	R557	ERJ2GEJ274	270k	
	R558	ERJ2GEJ470	47	
	R559	ERJ2GEJ101	100	
	R560	ERJ2GEJ181	180	
	R561	ERJ2GEJ102	1k	
	R562	ERJ2GEJ102	1k	
	R563	ERJ2GEJ101	100	
	R564	ERJ2RKF1802	18k	
	R565	ERJ2GEJ103	10k	
	R566	ERJ2GEJ123	12k	
	R567	ERJ2GEJ103	10k	
	R568	ERJ12YJ390	39	
	R569	ERJ2GEJ563	56k	
	R570	ERJ2GEJ562X	5.6k	
	R571	ERJ2GEJ561	560	
	R573	ERJ2GEJ103	10k	
	R574	PQ4R10XJ822	8.2k	S
	R576	ERJ2GEJ472X	4.7k	
	R577	ERJ2GEJ102	1k	
	R578	ERJ2GEJ332	3.3k	
	R579	ERJ2GEJ471	470	
	R580	ERJ2GEJ562X	5.6k	
	R581	ERJ2RKF4700	470	
	R582	ERJ2GEJ223	22k	
	R583	ERJ2GEJ562X	5.6k	
	R584	ERJ2RKF6201	6.2k	
	R585	ERJ2GEJ562X	5.6k	
	R587	ERJ2GEJ223	22k	

Safety	Ref. No.	Part No.	Part Name & Description	Remarks
	R588	ERJ2GEJ563	56k	
	R589	ERJ2GEJ562X	5. 6k	
	R594	ERJ2GEJ154	150k	
	R596	ERJ2GEJ472X	4. 7k	
	R750	ERJ2RKF49R9	49.9	
	R751	ERJ2RKF49R9	49.9	
	R752	ERJ2RKF49R9	49.9	
	R753	ERJ2RKF49R9	49.9	
	R754	ERJ2RKF6491	6. 49k	
	R755	ERJ2GEJ221	220	
	R759	ERJ2GEJ103	10k	
	R760	ERJ2GEJ331	330	
	R764	ERJ2GEJ330	33	
	R765	ERJ2GEJ330	33	
	R800	ERJ2RKF2202	22k	
	R801	ERJ2RKF1001	1k	
	R802	ERJ2RKF1002	10k	
	R803	ERJ2RKF4701	4. 7k	
	R804	ERJ2RKF9091	9. 09k	
	R805	ERJ2GEJ104	100k	
	R807	PQ4R18XJ472	4. 7k	S
	R808	ERJ2GEJ223	22k	
	R809	ERJ2GEJ181	180	
	R812	ERJ2RKF2201X	2. 2k	
	R813	ERJ2RKF1001	1k	
	R815	ERJ2RKF1002	10k	
	R817	ERJ2RKF2001	2k	
	R818	ERJ2RKF4701	4. 7k	
	R819	PQ4R18XJ471	470	S
	R820	PQ4R18XJ471	470	S
	R821	ERJ2GEJ473	47k	
	R822	ERJ2GEJ473	47k	
	R825	PQ4R18XJ102	1k	S
	R826	PQ4R18XJ102	1k	S
	L363	ERJ2GEJ221	220	
	L365	ERJ2GEJ330	33	
	L366	ERJ2GEJ330	33	
	L367	ERJ2GEJ330	33	
	L368	ERJ2GEJ330	33	
	L369	ERJ2GEJ221	220	
	L370	ERJ2GEJ221	220	
	L371	ERJ2GEJ221	220	
	R336	ERJ2GE0R00	0	
	R337	ERJ2GE0R00	0	
	R395	ERJ3GEY0R00	0	
	R396	ERJ3GEY0R00	0	
	R397	ERJ3GEY0R00	0	
	R398	ERJ3GEY0R00	0	
	L361	ERJ2GE0R00	0	
			(COMPONENTS PARTS)	
	RA314	EXB28V470JX	RESISTOR ARRAY	
	RA315	EXB28V470JX	RESISTOR ARRAY	
	RA316	EXB28V470JX	RESISTOR ARRAY	
	RA317	EXB28V470JX	RESISTOR ARRAY	
	RA318	EXB28V470JX	RESISTOR ARRAY	
	RA319	EXB28V470JX	RESISTOR ARRAY	
	RA320	EXB28V470JX	RESISTOR ARRAY	
	RA321	EXB28V473JX	RESISTOR ARRAY	
	RA322	EXB28V473JX	RESISTOR ARRAY	
	RA323	EXB28V473JX	RESISTOR ARRAY	
	RA324	EXB28V473JX	RESISTOR ARRAY	
	RA400	EXB28V560JX	RESISTOR ARRAY	
	RA401	EXB28V560JX	RESISTOR ARRAY	
	RA402	EXB28V560JX	RESISTOR ARRAY	
	RA403	EXB28V560JX	RESISTOR ARRAY	
	RA404	EXB28V470JX	RESISTOR ARRAY	
	RA405	EXB28V470JX	RESISTOR ARRAY	
	RA406	EXB28V470JX	RESISTOR ARRAY	
	RA413	EXB28V473JX	RESISTOR ARRAY	
	RA414	EXB28V473JX	RESISTOR ARRAY	
	RA750	EXB28V330	RESISTOR ARRAY	
	RA751	EXB28V330	RESISTOR ARRAY	
	RA752	EXB28V330	RESISTOR ARRAY	

Safety	Ref. No.	Part No.	Part Name & Description	Remarks
	RA753	EXB28V330	RESISTOR ARRAY	
			(CRYSTAL OSCILLATORS)	
	X300	H0J120500055	CRYSTAL OSCILLATOR	
	X302	H0J238500001	CRYSTAL OSCILLATOR	
	X303	H0A327200147	CRYSTAL OSCILLATOR	
	X750	H0J250500086	CRYSTAL OSCILLATOR	

18.2.3. Main Board (KX-MB2010)

Safety	Ref. No.	Part No.	Part Name & Description	Remarks
	PCB1	PNWP1B2010HX	MAIN BOARD ASS'Y (RTL)	
			(ICs)	
	IC300	C1ZBZ0003801	IC	S
	IC301	C0EBE0000504	IC	
	IC303	C0CBAAA00035	IC	
	IC400	C3ABRY000039	IC	
	IC402	PNWI2010HX	IC (ROM)	
	IC501	C0DBGY00330	IC	
	IC502	C0GBY0000066	IC	
	IC503	C1DB00001173	IC	
	IC504	C0BBBA000044	IC	S
	IC700	C0GBY0000066	IC	
	IC750	C1CB00002566	IC	
	IC800	C0DBAGE00028	IC	
			(TRANSISTORS)	
	Q500	B1ABCF000103	TRANSISTOR (SI)	S
	Q501	UNR92ANJ0L	TRANSISTOR (SI)	
	Q502	UNR92ANJ0L	TRANSISTOR (SI)	
	Q503	UNR92ANJ0L	TRANSISTOR (SI)	
	Q504	UNR92ANJ0L	TRANSISTOR (SI)	
	Q505	UNR92ANJ0L	TRANSISTOR (SI)	
	Q506	UNR92ANJ0L	TRANSISTOR (SI)	
	Q507	UNR921LJ0L	TRANSISTOR (SI)	S
	Q509	2SB1197KQ	TRANSISTOR (SI)	S
	Q510	B1CHND000004	TRANSISTOR (SI)	
	Q511	UNR92ANJ0L	TRANSISTOR (SI)	
	Q512	B1ABCF000103	TRANSISTOR (SI)	S
	Q514	2SD0874AS	TRANSISTOR (SI)	
	Q516	2SD0874AS	TRANSISTOR (SI)	
	Q517	2SD0874AS	TRANSISTOR (SI)	
	Q518	B1ADGE000004	TRANSISTOR (SI)	
	Q521	2SK3018	TRANSISTOR (SI)	S
	Q522	B1ABCF000103	TRANSISTOR (SI)	S
	Q523	B1ADGE000004	TRANSISTOR (SI)	
	Q524	UNR92ANJ0L	TRANSISTOR (SI)	
	Q525	UNR92ANJ0L	TRANSISTOR (SI)	
	Q526	UNR92ANJ0L	TRANSISTOR (SI)	
	Q527	UN9219J	TRANSISTOR (SI)	S
	Q528	UNR92ANJ0L	TRANSISTOR (SI)	
	Q529	B1ADCF000161	TRANSISTOR (SI)	
	Q530	2SK3018	TRANSISTOR (SI)	S
	Q700	B1ABCF000103	TRANSISTOR (SI)	S
	Q800	2SC4081R	TRANSISTOR (SI)	S
	Q801	UNR92A5J0L	TRANSISTOR (SI)	
	Q802	B1CHQD000001	TRANSISTOR (SI)	
	Q803	B1CHQD000001	TRANSISTOR (SI)	
	Q804	B1ABKD000001	TRANSISTOR (SI)	
	Q805	B1ABKD000001	TRANSISTOR (SI)	
	Q806	2SB1197KQ	TRANSISTOR (SI)	S
	Q807	2SB1197KQ	TRANSISTOR (SI)	S
			(DIODES)	
	D306	B0ZBZ0000146	DIODE (SI)	
	D308	B0BC5R000009	DIODE (SI)	
	D501	B0ACEL000004	DIODE (SI)	
	D503	B0ACEL000004	DIODE (SI)	
	D504	B0ACEL000004	DIODE (SI)	
	D800	B0JCPD000033	DIODE (SI)	
	D801	B0BC5R900006	DIODE (SI)	
	D803	B0JCPD000033	DIODE (SI)	
	D804	B0BC3R800009	DIODE (SI)	
	D805	B0BC01000014	DIODE (SI)	
	D806	B0BC01000014	DIODE (SI)	

Safety	Ref. No.	Part No.	Part Name & Description	Remarks
	DA300	PJVDJADAN202	DIODE (SI)	S
	DA500	PJVDJADAN202	DIODE (SI)	S
	LED750	B3ABB0000331	DIODE (SI)	
			(BATTERY)	
	BAT300	CR-2354/GUFK	BATTERY	
			(CAPACITORS)	
	C300	ECUE1C104ZFK	0.1	
	C301	ECUE1C104ZFK	0.1	
	C304	ECJ0EB0J224K	0.22	S
	C305	ECJ0EB0J224K	0.22	S
	C306	ECJ0EB0J224K	0.22	S
	C308	ECJ0EB0J224K	0.22	S
	C310	ECUE1H220JQC	22p	
	C311	ECUE1H270JQC	27p	
	C312	ECUE1A104KBQ	0.1	
	C315	ECUE1H100DCQ	10p	
	C316	ECUE1H8R0DCQ	8	
	C317	ECUE1H270JQC	27p	
	C318	ECUE1H120JQC	12p	
	C319	ECUE0J105KBQ	1	
	C321	ECUE1C104ZFK	0.1	
	C322	ECUE0J105KBQ	1	
	C325	ECUE1C104ZFK	0.1	
	C326	ECUE1C103KBQ	0.01	
	C327	ECUE1C104ZFK	0.1	
	C328	ECUE1C104ZFK	0.1	
	C329	ECUE1C104ZFK	0.1	
	C330	ECUE1C104ZFK	0.1	
	C331	ECUE1C104ZFK	0.1	
	C332	ECUE1C104ZFK	0.1	
	C333	ECUE1C104ZFK	0.1	
	C334	ECUE1C104ZFK	0.1	
	C335	ECUE1C104ZFK	0.1	
	C336	ECUE1C104ZFK	0.1	
	C337	ECUE1C104ZFK	0.1	
	C338	ECUE1C104ZFK	0.1	
	C339	ECUE1C104ZFK	0.1	
	C351	ECUE1H101JQC	100p	
	C352	ECUE1C104ZFK	0.1	
	C353	ECUE1C104ZFK	0.1	
	C354	ECUE1C104ZFK	0.1	
	C355	ECUE1C104ZFK	0.1	
	C357	ECUE1C104ZFK	0.1	
	C358	ECUE1C104ZFK	0.1	
	C359	ECUE1C104ZFK	0.1	
	C360	ECUE1C104ZFK	0.1	
	C361	ECUE1C104ZFK	0.1	
	C362	ECUE1C104ZFK	0.1	
	C363	ECUE1C104ZFK	0.1	
	C364	ECUE1C104ZFK	0.1	
	C400	ECUE1C104ZFK	0.1	
	C401	ECUE1C103KBQ	0.01	
	C402	ECUE1C104ZFK	0.1	
	C403	ECUE1C104ZFK	0.1	
	C404	ECUE1C104ZFK	0.1	
	C405	ECUE1C103KBQ	0.01	
	C406	ECUE1C104ZFK	0.1	
	C412	ECUE1C103KBQ	0.01	
	C413	ECUE1C104ZFK	0.1	
	C414	ECUE1C104ZFK	0.1	
	C419	ECUE1H101JQC	100p	
	C420	ECUE1H101JQC	100p	
	C421	ECUE1H101JQC	100p	
	C422	ECUE1H101JQC	100p	
	C423	ECUE1H101JQC	100p	
	C424	ECUE1H101JQC	100p	
	C425	ECUE1H101JQC	100p	
	C426	ECUE1H101JQC	100p	
	C427	ECUE1H101JQC	100p	
	C428	ECUE1H101JQC	100p	
	C429	ECUE1H101JQC	100p	
	C470	ECUE1H270JQC	27p	
	C471	ECUE1C104ZFK	0.1	

Safety	Ref. No.	Part No.	Part Name & Description	Remarks
	C501	ECUV1H104ZFK	0.1	
	C502	ECUE0J105KBQ	1	
	C503	ECUV1H104ZFK	0.1	
	C504	ECUE1C104ZFK	0.1	
	C505	F2G1V2210014	220	
	C506	ECUE1H100DCQ	10p	
	C507	ECUE1H102KBQ	0.001	
	C508	ECJ0EB1A473K	0.047	S
	C509	ECUE1A104KBQ	0.1	
	C510	ECUE1A104KBQ	0.1	
	C511	ECUE1H102KBQ	0.001	
	C512	FLJ0J1060006	10	
	C513	ECUV1A105ZFK	1	
	C514	ECUE1H101JQC	100p	
	C515	F2G1V2210014	220	
	C516	ECUE1H102KBQ	0.001	
	C517	ECUE1H102KBQ	0.001	
	C518	ECUV1H104ZFK	0.1	
	C520	ECUE1H102KBQ	0.001	
	C522	ECUE1H102KBQ	0.001	
	C524	F2G1V4700028	47	
	C525	ECUV1H104ZFK	0.1	
	C526	ECUE1H102KBQ	0.001	
	C527	ECUE1H102KBQ	0.001	
	C528	ECUE1H102KBQ	0.001	
	C529	ECUE1H102KBQ	0.001	
	C530	FLJ0J1060006	10	
	C531	FLJ0J1060006	10	
	C533	ECUE1A104KBQ	0.1	
	C534	ECUE1A104KBQ	0.1	
	C536	ECUE1A104KBQ	0.1	
	C537	ECUE1A104KBQ	0.1	
	C538	FLJ0J1060006	10	
	C540	ECUE1A104KBQ	0.1	
	C542	ECUE1A104KBQ	0.1	
	C543	ECUE1A104KBQ	0.1	
	C544	ECUE1C103KBQ	0.01	
	C545	ECUE0J105KBQ	1	
	C546	ECUE1C103KBQ	0.01	
	C547	ECUE1H101JQC	100p	
	C548	ECUE1H102KBQ	0.001	
	C549	F2G0J1010015	100	
	C550	F2G1C2200013	22	
	C551	ECUE1H102KBQ	0.001	
	C552	ECUE1C104ZFK	0.1	
	C553	ECUE1H102KBQ	0.001	
	C554	ECUE1H102KBQ	0.001	
	C555	ECUE1C104ZFK	0.1	
	C556	ECUE1H101JQC	100p	
	C557	ECUE1H181JQC	180p	
	C559	ECUE1H102KBQ	0.001	
	C563	ECUE1H102KBQ	0.001	
	C565	ECJ0EB1A473K	0.047	S
	C568	ECUE1H102KBQ	0.001	
	C569	ECJ0EB1A473K	0.047	S
	C571	ECUE0J105KBQ	1	
	C572	ECUE1C104ZFK	0.1	
	C645	ECUE1C104ZFK	0.1	
	C646	ECUE1C104ZFK	0.1	
	C647	ECUE1C104ZFK	0.1	
	C648	ECUE1C104ZFK	0.1	
	C649	ECUE1C104ZFK	0.1	
	C650	ECUE1C104ZFK	0.1	
	C651	ECUE1C104ZFK	0.1	
	C652	ECUE1C104ZFK	0.1	
	C653	ECUE1C104ZFK	0.1	
	C654	ECUE1C104ZFK	0.1	
	C655	ECUE1C104ZFK	0.1	
	C656	ECUE1C104ZFK	0.1	
	C657	ECUE1C104ZFK	0.1	
	C658	ECUE1C104ZFK	0.1	
	C659	ECUE1C104ZFK	0.1	
	C660	ECUE1C104ZFK	0.1	

Safety	Ref. No.	Part No.	Part Name & Description	Remarks
	C661	ECUE1C104ZFQ	0.1	
	C662	ECUE1C104ZFQ	0.1	
	C663	ECUE1C104ZFQ	0.1	
	C664	ECUE1C104ZFQ	0.1	
	C665	ECUE1C104ZFQ	0.1	
	C666	ECUE1C104ZFQ	0.1	
	C667	ECUE1C104ZFQ	0.1	
	C668	ECUE1C104ZFQ	0.1	
	C669	ECUE1C104ZFQ	0.1	
	C670	ECUE1C104ZFQ	0.1	
	C671	ECUV1H104ZV	0.1	
	C672	ECUV1H104ZV	0.1	
	C673	ECUV1H104ZV	0.1	
	C674	ECUE1C104ZFQ	0.1	
	C675	ECUE1C104ZFQ	0.1	
	C676	ECUE1C104ZFQ	0.1	
	C677	ECUE1C104ZFQ	0.1	
	C678	ECUE1C104ZFQ	0.1	
	C679	ECUE1C104ZFQ	0.1	
	C680	ECUE1C104ZFQ	0.1	
	C681	ECUE1C104ZFQ	0.1	
	C682	ECUE1C104ZFQ	0.1	
	C683	ECUE1C104ZFQ	0.1	
	C684	ECUE1C104ZFQ	0.1	
	C685	ECUE1C104ZFQ	0.1	
	C687	ECUE1C104ZFQ	0.1	
	C688	ECUE1C104ZFQ	0.1	
	C689	ECUE1C104ZFQ	0.1	
	C690	ECUE1C104ZFQ	0.1	
	C691	ECUE1C104ZFQ	0.1	
	C692	ECUE1C104ZFQ	0.1	
	C693	ECUE1C104ZFQ	0.1	
	C695	ECUE1C104ZFQ	0.1	
	C696	ECUE1C104ZFQ	0.1	
	C697	ECUE1C104ZFQ	0.1	
	C698	ECUE1C104ZFQ	0.1	
	C699	ECUE1C104ZFQ	0.1	
	C701	ECUE1H102KBQ	0.001	
	C702	ECUE1H102KBQ	0.001	
	C703	ECUE1H102KBQ	0.001	
	C704	ECUE1H102KBQ	0.001	
	C709	ECUE1H102KBQ	0.001	
	C710	ECUE1H102KBQ	0.001	
	C711	ECUE1H102KBQ	0.001	
	C712	ECUE1H102KBQ	0.001	
	C750	ECUE1H101JCQ	100p	
	C751	ECUE1C104ZFQ	0.1	
	C752	F2G0J4700013	47	
	C753	ECUE1C104ZFQ	0.1	
	C754	ECUE1A104KBQ	0.1	
	C755	ECUE1A104KBQ	0.1	
	C756	ECUE1H100DCQ	10p	
	C757	ECUE1H150JCQ	15p	
	C758	ECUE1C104ZFQ	0.1	
	C759	F1J0J1060006	10	
	C760	ECUE1C103KBQ	0.01	
	C762	F2G0J4700013	47	
	C763	ECUE1H220JCQ	22p	
	C764	ECUE1H220JCQ	22p	
	C765	ECUE1H220JCQ	22p	
	C766	ECUE1H220JCQ	22p	
	C767	ECUE1A104KBQ	0.1	
	C768	ECUE1A104KBQ	0.1	
	C769	F1J0J1060006	10	
	C770	ECUE1H101JCQ	100p	
	C800	F2H0J1010009	100	
	C801	ECUV1H104ZV	0.1	
	C802	PQCUV1A105KB	1	
	C803	ECUV1H104ZV	0.1	
	C804	F1L1V1060002	35	
	C805	F1L1V1060002	35	
	C806	ECUV1H104ZV	0.1	
	C807	ECUV1H104ZV	0.1	

Safety	Ref. No.	Part No.	Part Name & Description	Remarks
	C808	ECUV1H104ZV	0.1	
	C809	ECJ0EB1A473K	0.047	S
	C810	ECUV1H103KBV	0.01	
	C811	ECUV1A474KBV	0.47	
	C812	ECUV1H103KBV	0.01	
	C813	ECUV1A334KBV	0.33	
	C814	ECUE1A104KBQ	0.1	
	C817	F2H0J1010009	100	
	C818	PQCUV1A105KB	1	
	C819	PQCUV1C105ZF	1	S
	C820	PQCUV1C105ZF	1	S
			(CONNECTORS & JACKS)	
	CN300	K1FY104B0015	CONNECTOR, 8PIN	
	CN500	K1KA07A00257	CONNECTOR, 7PIN	
	CN501	K1KA05A00364	CONNECTOR, 5PIN	
	CN502	K1KA08AA0193	CONNECTOR, 8PIN	
	CN504	K1KA08A00498	CONNECTOR, 8PIN	
	CN505	K1KA08A00440	CONNECTOR, 8PIN	
	CN506	K1KA03AA0193	CONNECTOR, 3PIN	
	CN507	K1KA02AA0193	CONNECTOR, 2PIN	
	CN508	K1KA10A00412	CONNECTOR, 10PIN	
	CN509	K1KA04A00527	CONNECTOR, 4PIN	
	CN510	K1KA13A00130	CONNECTOR, 13PIN	
	CN511	K1KA08A00440	CONNECTOR, 8PIN	
	CN514	K1KA02AA0193	CONNECTOR, 2PIN	
	CN700	K1KA04A00644	CONNECTOR, 4PIN	
	CN701	K1KA04AA0193	CONNECTOR, 4PIN	
	CN750	K2LC1YYB0012	JACK	
			(FUSE)	
	F800	K5H302Y00003	FUSE	
			(COILS)	
	L300	G1BYYYYC00026	COIL	
	L502	PFVF2P221SG	COIL	S
	L800	G1C220MA0291	COIL	
	L801	G1C220MA0291	COIL	
			(FILTERS)	
	FLT500	J0HAAB000021	IC FILTER	
	L344	J0JCC0000286	IC FILTER	
	L345	J0JCC0000286	IC FILTER	
	L346	J0JCC0000286	IC FILTER	
	L347	J0JCC0000286	IC FILTER	
	L364	J0JCC0000274	IC FILTER	
	L500	J0JCC0000277	IC FILTER	
	L501	J0JCC0000276	IC FILTER	
	L503	J0JGC0000020	IC FILTER	
	L504	J0JGC0000020	IC FILTER	
	L750	J0JCC0000276	IC FILTER	
	L752	J0MAB0000185	IC FILTER	
	L753	J0MAB0000185	IC FILTER	
			(RESISTORS)	
	R302	ERJ2RKF49R9	49.9	
	R303	ERJ2GEJ472X	4.7k	
	R304	ERJ2GEJ101	100	
	R305	ERJ2GEJ103	10k	
	R307	ERJ2GEJ470	47	
	R308	ERJ2GEJ470	47	
	R309	ERJ2GEJ470	47	
	R315	ERJ2GEJ103	10k	
	R316	ERJ2GEJ103	10k	
	R335	ERJ2GEJ472X	4.7k	
	R338	ERJ2GEJ103	10k	
	R339	ERJ2GEJ223	22k	
	R340	ECUE1H220JCQ	22p	
	R348	ECUE1H220JCQ	22p	
	R349	ERJ2GEJ103	10k	
	R350	ERJ2GEJ103	10k	
	R351	ERJ2GEJ103	10k	
	R352	ERJ2GEJ103	10k	
	R353	ERJ2GEJ103	10k	
	R354	ERJ2GEJ103	10k	
	R355	ERJ2GEJ103	10k	
	R360	ERJ2GEJ103	10k	
	R363	ERJ2GEJ103	10k	

Safety	Ref. No.	Part No.	Part Name & Description	Remarks
	R365	ERJ2GEJ103	10k	
	R367	ERJ2GEJ470	47	
	R368	ERJ2GEJ470	47	
	R369	ERJ2GEJ470	47	
	R372	ERJ2GEJ103	10k	
	R373	ERJ2GEJ103	10k	
	R375	ERJ2GEJ221	220	
	R376	ERJ2RKF6981	6.98k	
	R378	ERJ2GEJ102	1k	
	R380	ERJ2GEJ1R0	1	
	R381	ERJ2GEJ1R0	1	
	R382	ERJ2GEJ1R0	1	
	R384	ERJ2GEJ101	100	
	R385	ERJ2GEJ1R0	1	
	R386	ERJ2GEJ221	220	
	R387	ERJ2GEJ105X	1M	
	R388	ERJ2GEJ184	180k	
	R389	ERJ2GEJ102	1k	
	R391	ERJ2GEJ103	10k	
	R399	ERJ2GEJ103	10k	
	R400	ERJ2GEJ470	47	
	R401	ERJ2GEJ680	68	
	R402	ERJ2GEJ470	47	
	R403	ERJ2GEJ470	47	
	R404	ERJ2GEJ470	47	
	R405	ERJ2GEJ470	47	
	R406	ERJ2GEJ470	47	
	R407	ERJ2GEJ470	47	
	R408	ERJ2GEJ470	47	
	R409	ERJ2GEJ680	68	
	R410	ERJ2GEJ680	68	
	R449	ERJ2GEJ103	10k	
	R501	ERJ2GEJ101	100	
	R502	ERJ2GEJ101	100	
	R503	ERJ2RKF6201	6.2k	
	R504	ERJ2GEJ473	47k	
	R505	ERJ2RKF1503	150k	
	R506	ERJ2GEJ223	22k	
	R507	ERJ2RKF2202	22k	
	R508	ERJ2GEJ102	1k	
	R509	ERJ2GEJ102	1k	
	R510	ERJ2GEJ562X	5.6k	
	R511	ERJ2GEJ181	180	
	R512	ERJ2GEJ563	56k	
	R513	ERJ2GEJ103	10k	
	R514	ERJ2RKF1503	150k	
	R515	ERJ2GEJ102	1k	
	R516	ERJ2GEJ823	82k	
	R517	ERJ2GEJ332	3.3k	
	R518	ERJ2GEJ472X	4.7k	
	R519	ERJ2GEJ472X	4.7k	
	R520	ERJ2GEJ102	1k	
	R521	ERJ2GEJ563	56k	
	R522	ERJ2GEJ103	10k	
	R523	ERJ2GEJ563	56k	
	R524	ERJ2GEJ472X	4.7k	
	R525	ERJ12YJ390	39	
	R526	ERJ2GEJ103	10k	
	R527	ERJ2GEJ562X	5.6k	
	R528	PQ4R10XJ332	3.3k	S
	R529	ERJ2GEJ103	10k	
	R530	ERJ2GEJ102	1k	
	R531	ERJ2GEJ562X	5.6k	
	R532	ERJ2GEJ103	10k	
	R533	ERJ2RKF1001	1k	
	R534	ERJ2GEJ473	47k	
	R535	ERJ2GEJ473	47k	
	R536	ERJ8RQFR39	0.39	
	R537	ERJ8RQFR39	0.39	
	R538	ERJ2GEJ102	1k	
	R539	ERJ2GEJ103	10k	
	R540	ERJ2GEJ221	220	
	R541	ERJ2GEJ122	1.2k	

Safety	Ref. No.	Part No.	Part Name & Description	Remarks
	R542	ERJ2GEJ122	1.2k	
	R543	ERJ3GEYJ180	18	
	R544	ERJ2GEJ122	1.2k	
	R545	ERJ2GEJ123	12k	
	R546	ERJ2GEJ122	1.2k	
	R547	ERJ2GEJ471	470	
	R548	ERJ3GEYJ1R2	1.2	
	R549	ERJ3GEYJ330	33	
	R550	ERJ2GEJ122	1.2k	
	R551	ERJ2GEJ274	270k	
	R552	ERJ2GEJ102	1k	
	R553	ERJ2GEJ820	82	
	R554	ERJ2GEJ122	1.2k	
	R555	ERJ2GEJ472X	4.7k	
	R556	ERJ3GEYJ390	39	
	R557	ERJ2GEJ274	270k	
	R558	ERJ2GEJ470	47	
	R559	ERJ2GEJ101	100	
	R560	ERJ2GEJ181	180	
	R561	ERJ2GEJ102	1k	
	R562	ERJ2GEJ102	1k	
	R563	ERJ2GEJ101	100	
	R564	ERJ2RKF1802	18k	
	R565	ERJ2GEJ103	10k	
	R566	ERJ2GEJ123	12k	
	R567	ERJ2GEJ103	10k	
	R568	ERJ12YJ390	39	
	R569	ERJ2GEJ563	56k	
	R570	ERJ2GEJ562X	5.6k	
	R571	ERJ2GEJ561	560	
	R573	ERJ2GEJ103	10k	
	R574	PQ4R10XJ822	8.2k	S
	R576	ERJ2GEJ472X	4.7k	
	R577	ERJ2GEJ102	1k	
	R578	ERJ2GEJ332	3.3k	
	R579	ERJ2GEJ471	470	
	R580	ERJ2GEJ562X	5.6k	
	R581	ERJ2RKF4700	470	
	R582	ERJ2GEJ223	22k	
	R583	ERJ2GEJ562X	5.6k	
	R584	ERJ2RKF6201	6.2k	
	R585	ERJ2GEJ562X	5.6k	
	R587	ERJ2GEJ223	22k	
	R588	ERJ2GEJ563	56k	
	R589	ERJ2GEJ562X	5.6k	
	R594	ERJ2GEJ154	150k	
	R596	ERJ2GEJ472X	4.7k	
	R700	ERJ2GEJ123	12k	
	R701	ERJ2GEJ274	270k	
	R702	ERJ2GEJ274	270k	
	R703	ERJ2GEJ562X	5.6k	
	R704	ERJ2GEJ562X	5.6k	
	R705	ERJ2GEJ563	56k	
	R706	ERJ2GEJ563	56k	
	R707	ERJ8RQFR33	0.33	
	R708	ERJ8RQFR33	0.33	
	R709	D0GA222JA015	2.2k	S
	R710	ERJ2GEJ123	12k	
	R711	ERJ2GEJ103	10k	
	R750	ERJ2RKF49R9	49.9	
	R751	ERJ2RKF49R9	49.9	
	R752	ERJ2RKF49R9	49.9	
	R753	ERJ2RKF49R9	49.9	
	R754	ERJ2RKF6491	6.49k	
	R755	ERJ2GEJ221	220	
	R759	ERJ2GEJ103	10k	
	R760	ERJ2GEJ331	330	
	R764	ERJ2GEJ330	33	
	R765	ERJ2GEJ330	33	
	R800	ERJ2RKF2202	22k	
	R801	ERJ2RKF1001	1k	
	R802	ERJ2RKF1002	10k	
	R803	ERJ2RKF4701	4.7k	

Safety	Ref. No.	Part No.	Part Name & Description	Remarks
	R804	ERJ2RKF9091	9.09k	
	R805	ERJ2GEJ104	100k	
	R807	PQ4R18XJ472	4.7k	S
	R808	ERJ2GEJ223	22k	
	R809	ERJ2GEJ181	180	
	R812	ERJ2RKF2201X	2.2k	
	R813	ERJ2RKF1001	1k	
	R815	ERJ2RKF1002	10k	
	R817	ERJ2RKF2001	2k	
	R818	ERJ2RKF4701	4.7k	
	R819	PQ4R18XJ471	470	S
	R820	PQ4R18XJ471	470	S
	R821	ERJ2GEJ473	47k	
	R822	ERJ2GEJ473	47k	
	R825	PQ4R18XJ102	1k	S
	R826	PQ4R18XJ102	1k	S
	L363	ERJ2GEJ221	220	
	L365	ERJ2GEJ330	33	
	L366	ERJ2GEJ330	33	
	L367	ERJ2GEJ330	33	
	L368	ERJ2GEJ330	33	
	L369	ERJ2GEJ221	220	
	L370	ERJ2GEJ221	220	
	L371	ERJ2GEJ221	220	
	R336	ERJ2GE0R00	0	
	R337	ERJ2GE0R00	0	
	R395	ERJ3GEY0R00	0	
	R396	ERJ3GEY0R00	0	
	R397	ERJ3GEY0R00	0	
	R398	ERJ3GEY0R00	0	
	L361	ERJ2GE0R00	0	
			(COMPONENTS PARTS)	
	RA314	EXB28V470JX	RESISTOR ARRAY	
	RA315	EXB28V470JX	RESISTOR ARRAY	
	RA316	EXB28V470JX	RESISTOR ARRAY	
	RA317	EXB28V470JX	RESISTOR ARRAY	
	RA318	EXB28V470JX	RESISTOR ARRAY	
	RA319	EXB28V470JX	RESISTOR ARRAY	
	RA320	EXB28V470JX	RESISTOR ARRAY	
	RA321	EXB28V473JX	RESISTOR ARRAY	
	RA322	EXB28V473JX	RESISTOR ARRAY	
	RA323	EXB28V473JX	RESISTOR ARRAY	
	RA324	EXB28V473JX	RESISTOR ARRAY	
	RA400	EXB28V560JX	RESISTOR ARRAY	
	RA401	EXB28V560JX	RESISTOR ARRAY	
	RA402	EXB28V560JX	RESISTOR ARRAY	
	RA403	EXB28V560JX	RESISTOR ARRAY	
	RA404	EXB28V470JX	RESISTOR ARRAY	
	RA405	EXB28V470JX	RESISTOR ARRAY	
	RA406	EXB28V470JX	RESISTOR ARRAY	
	RA413	EXB28V473JX	RESISTOR ARRAY	
	RA414	EXB28V473JX	RESISTOR ARRAY	
	RA750	EXB28V330	RESISTOR ARRAY	
	RA751	EXB28V330	RESISTOR ARRAY	
	RA752	EXB28V330	RESISTOR ARRAY	
	RA753	EXB28V330	RESISTOR ARRAY	
			(CRYSTAL OSCILLATORS)	
	X300	H0J120500055	CRYSTAL OSCILLATOR	
	X302	H0J238500001	CRYSTAL OSCILLATOR	
	X303	H0A327200147	CRYSTAL OSCILLATOR	
	X750	H0J250500086	CRYSTAL OSCILLATOR	

18.2.4. Operation Board

Safety	Ref. No.	Part No.	Part Name & Description	Remarks
	PCB2	PNLP2204RUZ	OPERATION BOARD ASS'Y (RTL)	
			(IC)	
	IC1	CLZBZ0004019	IC	
			(TRANSISTOR)	
	Q1	BIABGE000011	TRANSISTOR (SI)	
			(DIODES)	

Safety	Ref. No.	Part No.	Part Name & Description	Remarks
	D1	MA111	DIODE (SI)	S
	D2	MA111	DIODE (SI)	S
	LED2	B3ABA0000633	DIODE (SI)	
	LED3	B3ABA0000633	DIODE (SI)	
			(BUZZER)	
	BZ1	L0DAC000024	BUZZER	
			(CAPACITORS)	
	C1	ECUV1C104ZFV	0.1	
	C2	ECUV1C104ZFV	0.1	
	C3	ECUV1C104ZFV	0.1	
	C7	ECUV1H101JCV	100p	
	C8	ECUV1H102KBV	0.001	
	C10	ECUV1C104ZFV	0.1	
	C11	ECUV1C104ZFV	0.1	
	C12	ECUV1H391JCV	390p	S
	C13	ECUV1H101JCV	100p	
	C14	ECUV1H101JCV	100p	
	C16	ECUV1H100JCV	10p	
	C17	ECEA1CK101	100	S
	C18	ECUV1C104ZFV	0.1	
	C20	ECUV1H272KBV	0.0027	
	C21	ECUV1H152KBV	0.0015	
	C22	ECUV1H152KBV	0.0015	
	C23	ECUV1C224ZFV	0.22	S
			(LIQUID CRYSTAL DISPLAY)	
	CN1	L5DAAYY00017	LIQUID CRYSTAL DISPLAY	
			(CONNECTOR)	
	CN2	K1KA08B00243	CONNECTOR, 8PIN	
			(RESISTORS)	
	R2	ERJ3GEYJ241	240	
	R3	ERJ3GEYJ241	240	
	R5	ERJ3GEYJ123	12k	
	R6	ERJ3GEYJ102	1k	
	R7	ERJ3GEYJ102	1k	
	R8	ERJ3GEYJ47	4.7	
	R10	ERJ3GEYJ470	47	
	R11	ERJ3GEYJ101	100	
	R12	ERJ3GEYJ101	100	
	R13	ERJ3GEYJ101	100	
	R14	ERJ3GEYJ332	3.3k	
	R15	ERJ3GEYJ123	12k	
	R16	ERJ3GEYJ151	150	
	R17	ERJ3GEYJ472	4.7k	
	R18	ERJ3GEYJ102	1k	
	R19	ERJ3GEYJ474	470k	
	R20	ERJ3GEYJ181	180	
	R21	ERJ3GEYJ181	180	
	R22	ERJ3GEYJ181	180	
	R23	ERJ3GEYJ181	180	
	R24	ERJ3GEYJ181	180	
	R25	ERJ3GEYJ181	180	
	R26	ERJ3GEYJ181	180	
	R27	ERJ3GEYJ181	180	
	R28	ERJ8GEY0R00	0	
			(SWITCHES)	
	SW1	K0H1BA000259	SWITCH	
	SW2	K0H1BA000259	SWITCH	
	SW3	K0H1BA000259	SWITCH	
	SW4	K0H1BA000259	SWITCH	
	SW5	K0H1BA000259	SWITCH	
	SW6	K0H1BA000259	SWITCH	
	SW7	K0H1BA000259	SWITCH	
	SW8	K0H1BA000259	SWITCH	
	SW10	K0H1BA000259	SWITCH	
	SW11	K0H1BA000259	SWITCH	
	SW12	K0H1BA000259	SWITCH	
	SW13	K0H1BA000259	SWITCH	
	SW15	K0H1BA000259	SWITCH	
	SW16	K0H1BA000259	SWITCH	
	SW17	K0H1BA000259	SWITCH	
	SW20	K0H1BA000259	SWITCH	
	SW21	K0H1BA000259	SWITCH	

Safety	Ref. No.	Part No.	Part Name & Description	Remarks
	SW24	KOH1BA000259	SWITCH	
	SW27	KOH1BA000259	SWITCH	
	SW29	KOH1BA000259	SWITCH	
	SW30	KOH1BA000259	SWITCH	
	SW31	KOH1BA000259	SWITCH	
	SW32	KOH1BA000259	SWITCH	
	SW34	KOH1BA000259	SWITCH	
	SW35	KOH1BA000259	SWITCH	
	SW36	KOH1BA000259	SWITCH	
	SW37	KOH1BA000259	SWITCH	
			(THERMISTOR)	
	TH1	D4CCY1030002	THERMISTOR	

18.2.5. Sensor Board Parts

18.2.5.1. Toner Sensor Board

Safety	Ref. No.	Part No.	Part Name & Description	Remarks
	PCB3	PNLP2209RU-A	TONER SENSOR BOARD ASS'Y (RTL)	
			(CAPACITOR)	
	C57	ECUV1C104ZFV	0.1	
			(CONNECTORS)	
	CN64	K1KA10A00412	CONNECTOR, 10PIN	
	CN65	K1KA04A00527	CONNECTOR, 4PIN	
	CN66	K1KA04A00527	CONNECTOR, 4PIN	
	CN67	K1KA05A00364	CONNECTOR, 5PIN	
			(PHOTO ELECTRIC TRANSDUCER)	
	IC51	B4ZZ00000021	PHOTO ELECTRIC TRANSDUCER	

18.2.5.2. Fuser Board

Safety	Ref. No.	Part No.	Part Name & Description	Remarks
	PCB4	PNLP2209RU-B	FUSER BOARD ASS'Y (RTL)	
			(CAPACITOR)	
	C61	ECUV1H102KBV	0.001	
			(CONNECTORS)	
	CN52	K1KA03B00201	CONNECTOR, 3PIN	
	CN53	K1KA04B00225	CONNECTOR, 4PIN	
			(PHOTO ELECTRIC TRANSDUCER)	
	PS50	B3NAA0000106	PHOTO ELECTRIC TRANSDUCER	
			(RESISTOR)	
	R54	ERJ3GEYJ181	180	

18.2.5.3. Pickup Sensor Board

Safety	Ref. No.	Part No.	Part Name & Description	Remarks
	PCB5	PNWP2B2030RU	PICKUP SENSOR BOARD ASS'Y (RTL)	
			(CONNECTORS)	
	CN51	K1KA05B00189	CONNECTOR, 5PIN	
	CN63	K1KA03BA0061	CONNECTOR, 3PIN	
			(SWITCHE)	
	SW50	PFSH1A003Z	PUSH SWITCH	

18.2.5.4. Registration Sensor Board

Safety	Ref. No.	Part No.	Part Name & Description	Remarks
	PCB6	PNLP2209RU-D	RESIST SENSOR BOARD ASS'Y (RTL)	
			(CAPACITORS)	
	C50	ECUV1H102KBV	0.001	
	C51	ECUV1H102KBV	0.001	

Safety	Ref. No.	Part No.	Part Name & Description	Remarks
			(CONNECTOR)	
	CN50	K1KA04B00225	CONNECTOR, 4PIN	
			(PHOTO ELECTRIC TRANSDUCERS)	
	PS51	B3NAA0000106	PHOTO ELECTRIC TRANSDUCER	
	PS52	B3NAA0000106	PHOTO ELECTRIC TRANSDUCER	
			(RESISTORS)	
	R50	ERJ3GEYJ181	180	
	R51	ERJ3GEYJ181	180	

18.2.5.5. Varistor Sensor Board

Safety	Ref. No.	Part No.	Part Name & Description	Remarks
	PCB7	PNLP2209RU-E	VARISTOR SENSOR BOARD ASS'Y (RTL)	
			(VARISTOR)	
	ZNR50	PFRV271NS05K	VARISTOR	

18.2.5.6. Flatbed Relay Board

Safety	Ref. No.	Part No.	Part Name & Description	Remarks
	PCB8	PNLP2209RU-F	FLATBED RELAY BOARD ASS'Y (RTL)	
			(CAPACITORS)	
	C64	ECUV1C104ZFV	0.1	
	C65	ECUV1C104ZFV	0.1	
			(CONNECTORS)	
	CN59	K1KA13B00063	CONNECTOR, 13PIN	
	CN60	K1KA04B00225	CONNECTOR, 4PIN	
	CN61	K1MN12BA0222	CONNECTOR, 12PIN	
	CN62	K1KA04BA0061	CONNECTOR, 4PIN	
	CN68	K1KA03B00201	CONNECTOR, 3PIN	
			(COIL)	
	L54	PQLQR2KB113T	COIL	S
			(RESISTORS)	
	R55	ERJ3GEYJ472	4.7k	
	R56	ERJ3GEYJ471	470	

18.2.5.7. ADF Sensor Board (KX-MB2010 ONLY)

Safety	Ref. No.	Part No.	Part Name & Description	Remarks
	PCB9	PNLP2209RU-G	ADF SENSOR BOARD ASS'Y (RTL)	
			(CAPACITORS)	
	C55	ECUV1H102KBV	0.001	
	C56	ECUV1H102KBV	0.001	
			(CONNECTOR)	
	CN56	K1KA04B00225	CONNECTOR, 4PIN	
			(PHOTO ELECTRIC TRANSDUCERS)	
	PS53	B3NAA0000105	PHOTO ELECTRIC TRANSDUCER	
	PS54	B3NAA0000105	PHOTO ELECTRIC TRANSDUCER	
			(RESISTORS)	
	R52	ERJ3GEYJ181	180	
	R53	ERJ3GEYJ181	180	

18.2.5.8. CIS Home Sensor Board

Safety	Ref. No.	Part No.	Part Name & Description	Remarks
	PCB11	PNLP2209RU-J	CIS HOME SENSOR BOARD ASS'Y (RTL)	
			(CAPACITOR)	
	C60	ECUV1H102KBV	0.001	

Safety	Ref. No.	Part No.	Part Name & Description	Remarks
			(CONNECTOR)	
	CN69	K1KA03A00495	CONNECTOR, 3PIN	
			(PHOTO ELECTRIC TRANS-DUCER)	
	PS55	B3NAA0000106	PHOTO ELECTRIC TRANS-DUCER	

18.2.6. High Voltage Power Board

Safety	Ref. No.	Part No.	Part Name & Description	Remarks
△	PCB12	N0GG4E000006	HIGH VOLTAGE POWER BOARD ASS'Y (RTL)	
			(IC)	
	IC1	PH1193AC001	IC	
			(TRANSISTORS)	
	Q3	PT2394DL001	TRANSISTOR(SI)	
	Q62	PT2394DL001	TRANSISTOR(SI)	
			(FUSE)	
	F1	PK7130AA001	FUSE	
			(SWITCHE)	
△	SW1	PFSHSS3FLP3D	PUSH SWITCH	S

18.2.7. Low Voltage Power Board

Safety	Ref. No.	Part No.	Part Name & Description	Remarks
△	PCB13	N0AC2GH00001	LOW VOLTAGE POWER BOARD ASS'Y (RTL)	
			(TRANSISTOR)	
△	Q1	PT3565KL001	TRANSISTOR(SI)	
			(DIODES)	
△	D1	PD1146AC001	DIODE(SI)	
	D104	PD4145AA005	DIODE(SI)	
	D503	PD4068AQ075	DIODE(SI)	
			(CAPACITOR)	
△	C5	PC3126YS560	ELECTROLYTIC CAPACITOR, AL	
			(FUSES)	
△	F1	PK7102AS001	FUSE	
△	F2	PK7102AS004	FUSE	
△	F101	PK7154AR003	FUSE	
			(THYRISTOR)	
△	SCR51	PD5108AL001	THYRISTOR	

K.T
KXMB2000HXB
KXMB2010HXB