

Order No. MOD1107337CE

# Service Manual

Microwave Oven

Model No. NN-GM231W



**20L**  
**White**  
**CIS**

## **⚠ WARNING**

This service information is designed for experienced repair technicians only and is not designed for use by the general public. It does not contain warnings or cautions to advise non-technical individuals of potential dangers in attempting to service a product. Products powered by electricity should be serviced or repaired only by experienced professional technicians. Any attempt to service or repair the product or products dealt with in this service information by anyone else could result in serious injury or death.

## **IMPORTANT SAFETY NOTICE**

There are special components used in this equipment which are important for safety. These parts are marked by **⚠** in the Schematic Diagrams, Circuit Board Diagrams, Exploded Views and Replacement Parts List. It is essential that these critical parts should be replaced with manufacturer's specified parts to prevent shock, fire or other hazards. Do not modify the original design without permission of manufacturer.

## Specifications

Power Requirement	220 Volts AC 50 Hz Microwave 1250W (5.6 A) Grill 1000 W (4.1 A) Single phase, 3 wire grounded
Power Output	800 Watts full microwave power (IEC60705)
Microwave Frequency	2,450 MHz
Magnetron	2M219J
Timer	0 ~ 35 min.
Outside Dimensions	443(W) x 258 (H) x 340(D) mm
Cavity Dimensions	306(W) x 215(H) x 308(D) mm
Net Weight	12.3 kg (approx.)
Shipping weight	13.5 kg (approx.)

Specifications subject to change without notice.

**Panasonic**<sup>®</sup>

© Panasonic Corporation 2011 Unauthorized copying and distribution is a violation of law

### WARNING

This product should be serviced only by trained qualified personnel.

This service manual covers products for following markets.

When troubleshooting or replacing parts, please refer to the country identifications shown below for your applicable product specification.

ZPE.....For CIS countries

### CAUTION

#### About lead free solder (PbF)

**Distinction of PbF PCB:** PCBs (manufactured) using lead free solder will have a PbF stamp on the PCB.

**Caution:** ● Pb free solder has a higher melting point than standard solder; Typically the melting point is 30 - 40°C higher. Please use a high temperature soldering iron. In case of the soldering iron with temperature control, please set it to  $370 \pm 10^{\circ}\text{C}$ .

● Pb free solder will tend to splash when heated too high (about  $600^{\circ}\text{C}$ )

## SAFETY PRECAUTIONS

This device is to be serviced only by properly qualified service personnel.

Consult the service manual for proper service procedures to assure continued safety operation and for precautions to be taken to avoid possible exposure to excessive microwave energy.

### PRECAUTIONS TO BE OBSERVED BEFORE AND DURING SERVICING TO AVOID POSSIBLE EXPOSURE TO EXCESSIVE MICROWAVE ENERGY

- A) Do not operate or allow the oven to be operated with the door open.
- B) Make the following safety checks on all ovens to be serviced before activating the magnetron or other microwave source, and make repairs as necessary; (1) interlock operation, (2) proper door closing, (3) seal and sealing surfaces (arcing, wear, and other damage), (4) damage to or loosening of hinges and latches, (5) evidence of dropping or abuse.
- C) Before turning on microwave power for any service test or inspection within the microwave generating compartments, check the magnetron, wave guide or transmission line, and cavity for proper alignment, integrity, and connections.
- D) Any defective or misadjusted components in the interlock, monitor, door seal, and microwave generation and transmission systems shall be repaired, replaced, or adjusted by procedures described in this manual before the oven is released to the owner.
- E) A microwave leakage check to verify compliance with the Federal Performance Standard should be performed on each oven prior to release to the owner.

### CAUTION MICROWAVE RADIATION

DO NOT BECOME EXPOSED TO RADIATION FROM THE MICROWAVE GENERATOR OR OTHER PARTS CONDUCTING MICROWAVE ENERGY.

# CONTENTS

	(Page)
<b>SAFETY PRECAUTIONS</b> .....	<b>Inside front cover</b>
<b>POWER LEVEL AND ACCESSORIES</b> .....	<b>1-1</b>
<b>CAUTIONS</b> .....	<b>2-1</b>
<b>INSTALLATIONS</b> .....	<b>3-1</b>
<b>OPERATING INSTRUCTIONS</b> .....	<b>4-1</b>
FEATURES .....	4-1
CONTROL PANEL .....	4-1
OPERATING SEQUENCE .....	4-2
SCHEMATIC DIAGRAM .....	4-3
CIRCUIT DESCRIPTION .....	4-4
<b>SERVICE INFORMATION</b> .....	<b>5-1</b>
TOOLS AND MEASURING INSTRUMENTS .....	5-1
MICROWAVE LEAKAGE TEST .....	5-1
MEASUREMENT OF MICROWAVE POWER OUTPUT .....	5-3
DISASSEMBLY AND ADJUSTMENT .....	5-3
INTERLOCK CONTINUITY TEST .....	5-7
COMPONENT TEST PROCEDURE .....	5-8
TROUBLE SHOOTING .....	5-12
<b>EXPLODED VIEW</b> .....	<b>6-1</b>
<b>REPLACEMENT PARTS LIST</b> .....	<b>7-1</b>
<b>SCHEMATIC DIAGRAM OF P.C.B.</b> .....	<b>8-1</b>

# POWER LEVEL & ACCESSORIES

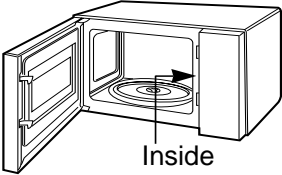
ITEM	DESCRIPTION
Control Complement	Microwave Power for Variable Cooking Power level Max <b>800 Watts</b> Medium <b>700 Watts</b> Low <b>360 Watts</b> Defrost <b>270 Watts</b> Warm <b>200 Watts</b>
Rating Label Location	
Accessories	Instruction manual Glass Tray Roller Ring Wire Rack
This microwave oven is designed for household use only. It is not recommended for commercial purposes.	

# CAUTIONS

Unlike other appliances, the microwave oven is high-voltage and high-current equipment. Though it is free from danger in ordinary use, extreme care should be taken during repair.

- DO NOT operate on a 2-wire extension cord during repair and use.
- NEVER TOUCH any oven components or wiring during operation.
- BEFORE TOUCHING any parts of the oven, always remove the power plug from the outlet.
- For about 30 seconds after the oven stops, an electric charge remains in the high voltage capacitor. When replacing or checking, you must discharge the high voltage capacitor by shorting across the two terminals with an insulated screwdriver.

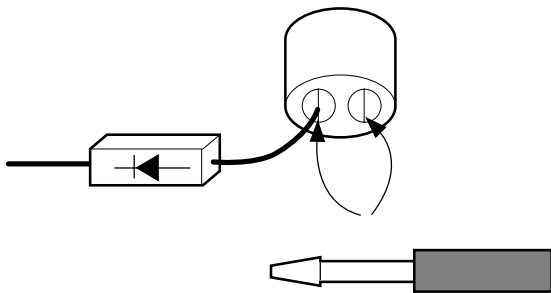

- Remove your watches whenever working close to or replacing the Magnetron.
- NEVER operate the oven with no load.
- NEVER injure the door seal and front plate of the oven cavity.
- NEVER put iron tools on the magnetron.
- NEVER put anything into the latch hole and the interlock switches area.

## MICROWAVE RADIATION

Personnel should not be exposed to the microwave energy which may radiate from the magnetron or other microwave generating device if it is improperly used or connection. All input and output microwave connections, waveguide, flange and gasket must be secure never operate the device without a microwave energy absorbing load attached. Never look into an open waveguide or antenna while the device is energized.

- Proper operation of the microwave oven requires that the magnetron be assembled to the waveguide and cavity. Never operate the magnetron unless it is properly installed.
- **Be sure that the magnetron gasket is properly installed around the dome of the tube whenever installing the magnetron.**

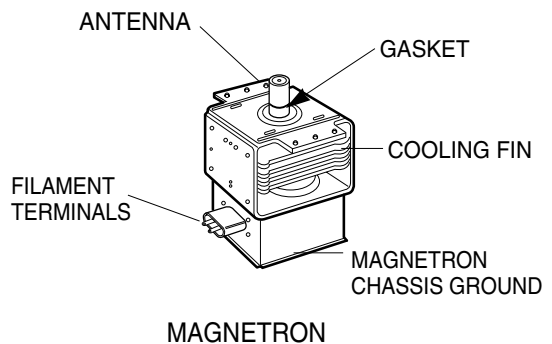

**THE OVEN IS TO BE SERVICED ONLY BY PROPERLY QUALIFIED SERVICE PERSONNEL.**

# INSTALLATIONS

**BEFORE YOU BEGIN, READ THE FOLLOWING INSTRUCTIONS COMPLETELY AND CAREFULLY.**

## INSTALLING

1. Empty the microwave oven and clean inside it with a soft, damp cloth. Check for damage such as misaligned door, damage around the door or dents inside the cavity or on the exterior.
2. Put the oven on a counter, table, or shelf that is strong enough to hold the oven and the food and utensils you put in it. (The control panel side of the oven is the heavy side. Use care when handling.)
3. Do not block the vent and the air intake openings. Blocking vent or air intake openings can cause damage to the oven and poor cooking results. Make sure the microwave oven legs are in place to ensure proper air flow.
4. The oven should not be installed in any area where heat and steam are generated, because they may damage the electronic or mechanical parts of the unit.  
Do not install the oven next to a conventional surface unit or above a conventional wall oven.
5. Use microwave oven in an ambient temperature less than 104°F(40°C).
6. Place the microwave oven on a sturdy and flat surface at least 10 cm(4 inches) from the wall.
7. Place the microwave oven as far away as possible from TV, RADIO, COMPUTER, etc., to prevent interference.

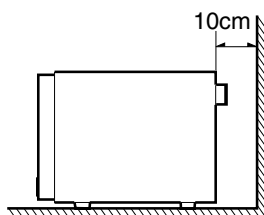

## EARTHING INSTRUCTIONS

This microwave oven is designed to be used in a fully earthed condition. It is imperative, therefore, to make sure it is properly earthed before servicing

### WARNING- THIS APPLIANCE MUST BE EARTHED

#### IMPORTANT

The wires in this mains lead are colored in accordance with the following code:

<b>Green-and-yellow:</b>	<b>Earth</b>
<b>Blue:</b>	<b>Neutral</b>
<b>Brown:</b>	<b>Live</b>

As the colors of the wires in the mains lead of this appliance may not correspond with the colored markings identifying the terminals in your plug, proceed as follows.

The wire which is colored **green-and-yellow** must be connected to the terminal in the plug which is marked with the letter **E** or by the **earth symbol** ( $\perp$ ) or colored **green** or **green-and-yellow**.

The wire which is colored **blue** must be connected to the terminal in the plug which is marked with the letter **N** or colored **black**.

The wire which is colored **brown** must be connected to the terminal in the plug which is marked with the letter **L** or colored **red**.

# OPERATING INSTRUCTIONS

## FEATURES

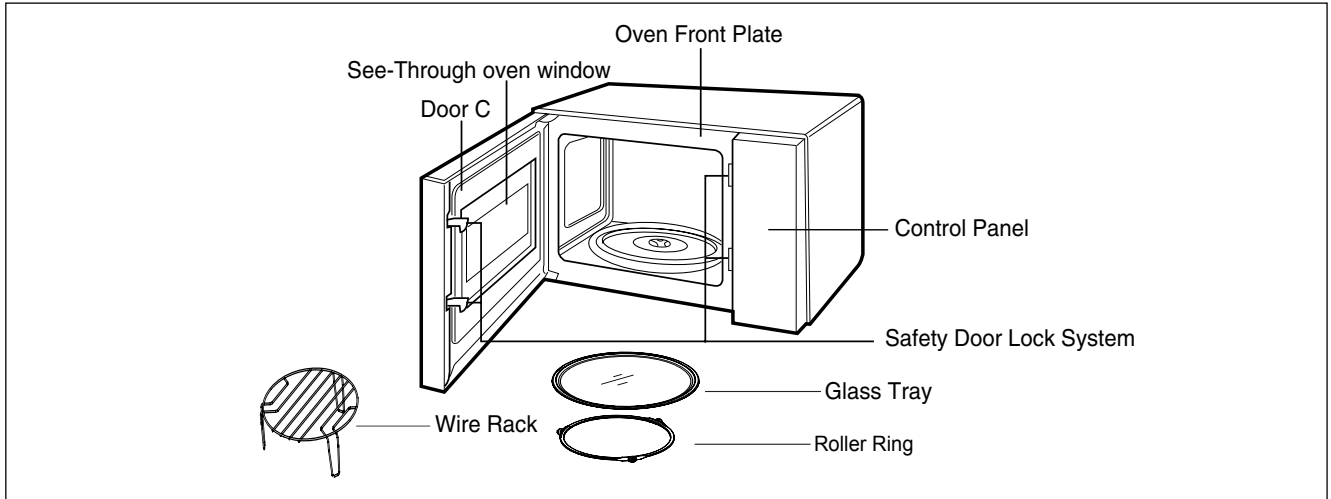

## CONTROL PANEL

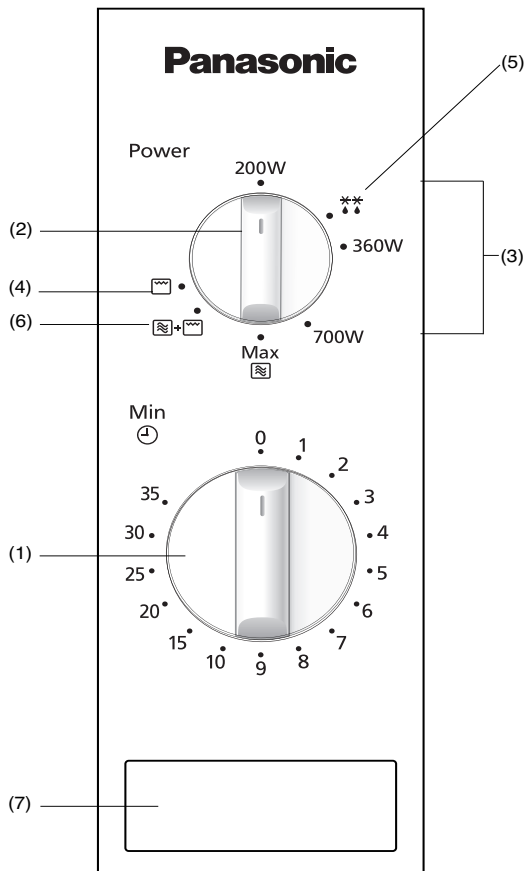

- (1) Timer
- (2) Cooking Mode Selection Dial
- (3) Microwave Power
- (4) Grill Setting
- (5) Defrost Power
- (6) Combination Setting
- (7) Door release button

\*The design of your control panel may vary from the panel displayed (depending on colour), but the words on the pads will be the same.

# OPERATING SEQUENCE

---

## MICROWAVE COOKING

1. Open the oven door, place the food on the turntable in the oven, and close the oven door.
2. Set the microwave power selector to the desired power level. There are five power levels from 200W to MAX. The power selector can be set to any one of these positions.

POSITIONS	
Max	<b>800 Watts</b>
Medium	<b>700 Watts</b>
Low	<b>360 Watts</b>
Defrost	<b>270 Watts</b>
Warm	<b>200 Watts</b>

3. Set the timer to the desired cooking time. The turntable begins to rotate and cooking starts. At the end of cooking time you will hear a single ring sound, and the lamp is turned off.



### NOTE:

- Each number represents minutes. To ensure accurate timing, it is advisable to turn the timer knob slightly passed the desired cooking time and then back to the proposed setting.
- Press the door opener to check the cooking condition during oven operation. Opening the door during oven operation automatically turns off the oven and stops the timer. If cooking is to continue, close the door. Cooking will be resumed until the full cooking time has elapsed.

## GRILL COOKING

1. Open the oven door, place the food on the rack in the oven, and close the oven door.
2. Set the  function.
3. Set the timer to the desired cooking time. The turntable begins to rotate, cooking starts, and the lamp is turned on. At the end of the cooking time you will hear a ring sound and the lamp is turned off.

## COMBI COOKING +

1. Open the oven door, place the food on the rack in the oven, and close the oven door.
  2. Set the  +  function.
  3. Set the timer to the desired cooking time. The turntable begins to rotate, cooking starts, and the lamp is turned on. At the end of the cooking time you will hear a ring sound and the lamp is turned off.
- Refer to the note under MICROWAVE COOKING if you want to check the cooking condition.
  - Don't touch the front screen of the door during grill & combi operation, because the temperature of the glass may rise to up to 100°C. Prevent children from touching the front screen!
  - When the grill & combi is operated for the first time after purchasing the oven, slight smoke and smell may occur. These will soon disappear.



# SCHEMATIC DIAGRAM

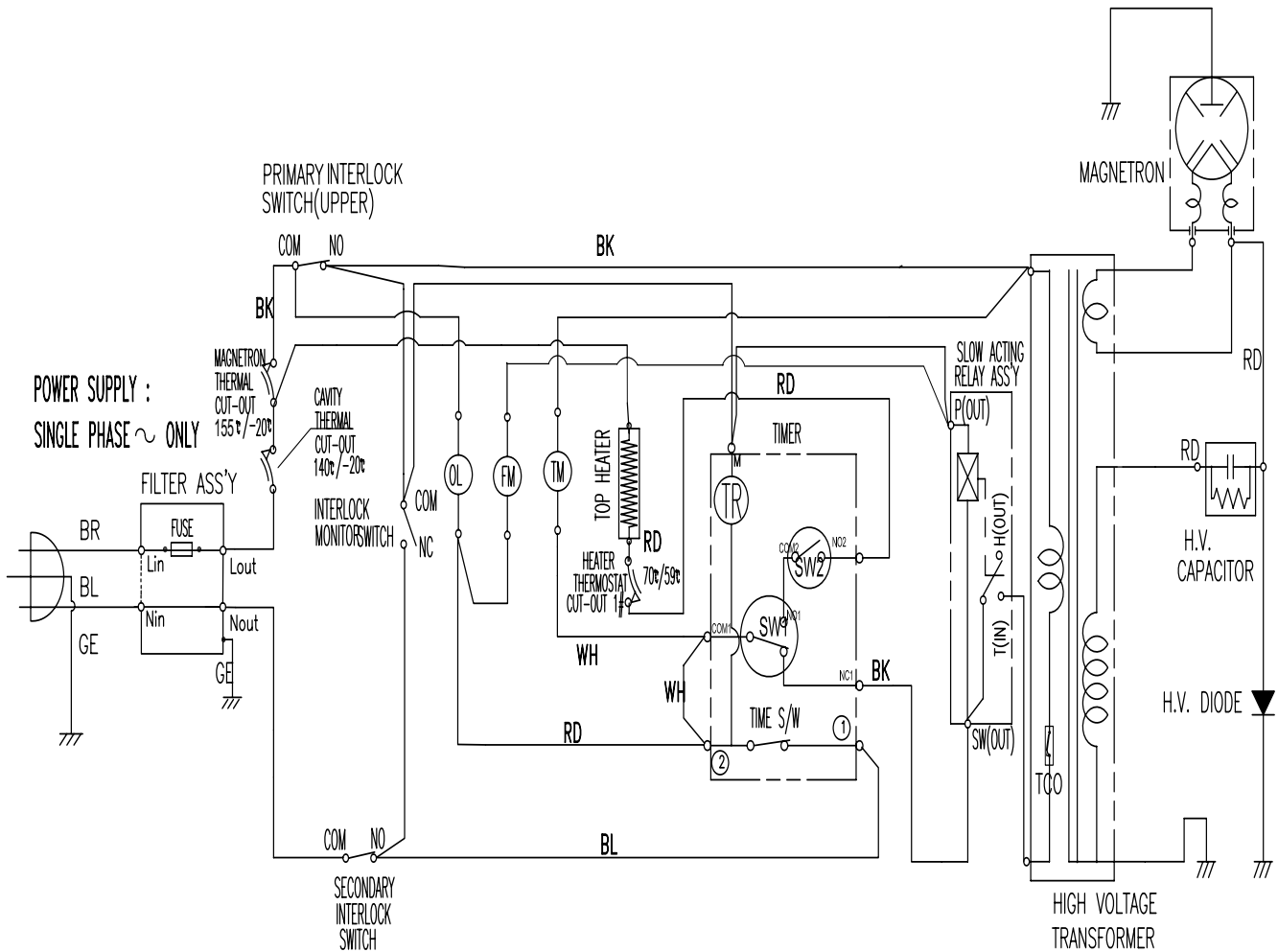

NOTE: OL : OVEN LAMP  
 FM : FAN MOTOR  
 TM : TURNTABLE MOTOR  
 TR : TIMER MOTOR  
 V.P.C.: VARIABLE POWER CONTROLLER

DOOR : CLOSED  
 TIMER : OFF  
 V.P.C. : HIGH

BEFORE SERVICING Discharge the high voltage Capacitor by shorting the negative high voltage Terminal of it to chassis ground.

SYMBOL	COLOR
GE	GREEN-YELLOW
WH	WHITE
BR	BROWN
BL	BLUE
RD	RED
YW	YELLOW
PK	PINK
GN	GREEN
BK	BLACK

# CIRCUIT DESCRIPTION

- As the door is closed, the contact of MONITOR SWITCH opens. This switch creates the short circuit to blow fuse during operation under abnormal condition. (ie, should the contacts of primary and secondary switch fail to open the circuit)
- The latches are secured by Door hook. The oven light turns on while the oven is in operation.

## WHEN MICROWAVE POWER LEVEL AND COOKING TIME SET

- The contacts of the timer switch changes to ON position when the timer knob is rotated.
- Set the power control knob at Max, The contacts of SW1 (COM1 and NC1) connected.
- The contacts of primary and secondary switch close the circuit.
- Input Volts AC. the slow acting relay assy works and connect the circuit. Electricity apply to the high voltage transformer and the microwave oven begin to operate.

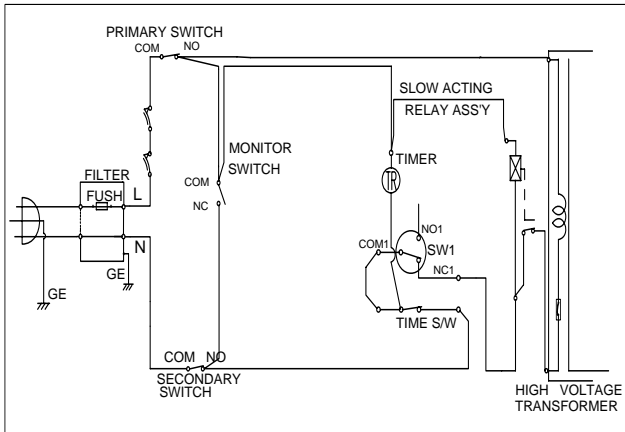

- Turntable rotates.
- The fan motor rotates and cools the magnetron by blowing the air (coming from the intake holes on the backplate) over the magnetron.
- The air is also directed into the oven to exhaust the vapor in the oven through the left side.
- Timer starts rotating.
- 3.2 volts AC is generated from the filament winding of the high voltage transformer. This 3.2 volts is applied to the magnetron to heat the magnetron filament through two noise preventing choke coils. A high voltage of approximately 2100 volts AC is generated in the secondary of the high voltage transformer which is increased by the action of the diode and charging of the high voltage capacitor. The negative DC voltage is then applied to the filament of the magnetron.

## WHEN THE DOOR IS OPENED DURING COOKING

- Both primary switch and secondary switch open to cut off the primary winding voltage to the high voltage transformer to stop microwave oscillation.
- Timer, turntable and fan motor stop.
- As the door is opened, if the contact of primary switch and secondary switch fail to open, the fuse opens due to the large current surge caused by the monitor switch activation which in turn stops magnetron, oscillation.

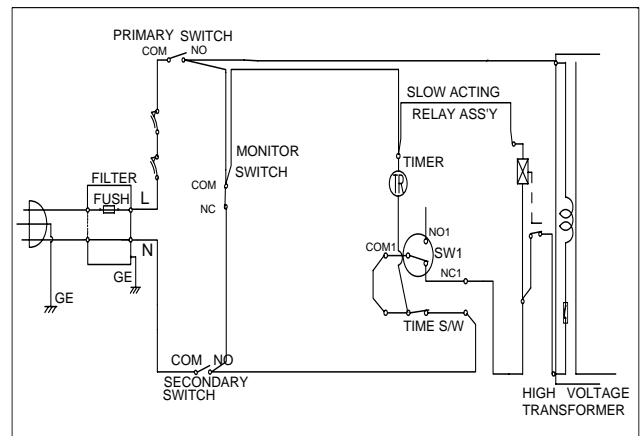

## WHEN THE GRILL COOKING FUNCTION SELECTED

- The contacts of the timer switch change to ON position.
- Set the power control knob at "Grill". The contacts of SW1 (COM1 and NO1) connected.
- Input volts AC is applied to the grill heater through thermostat-grill as shown.
- The fan motor and turntable rotates.

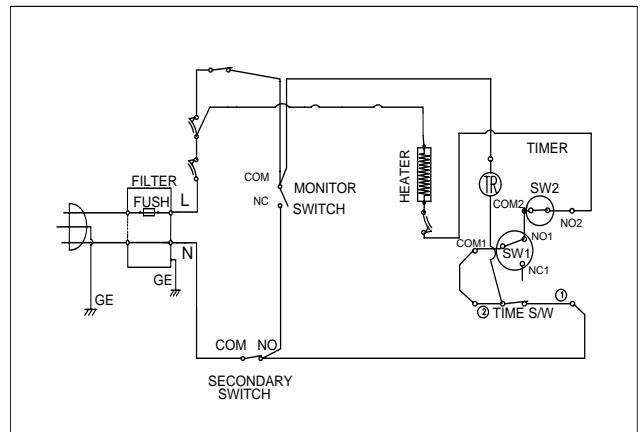

# SERVICE INFORMATION

## TOOLS AND MEASURING INSTRUMENTS

### NECESSARY TOOLS

Tools normally used for TV servicing are sufficient. Standard tools are listed below.

- Diagonal pliers
- Long nose pliers
- Phillips screwdriver
- Flat blade screwdriver
- Wrench (size 5mm)
- Nutdriver (size 5mm)
- Adjustable wrench
- Soldering iron
- Solder
- Vinyl insulation tape
- Polishing cloth

### NECESSARY MEASURING INSTRUMENTS

- TESTER(VOLTS-DC, AC., Ohmmeter)
- Microwave survey meter
  - Holaday HI-1500
  - HI-1501
  - Narda 8100
  - 8200
- Inch scale
- 600 cc non conductive material beaker (glass or plastic), inside diameter: approx. 8.5 cm(3<sup>1</sup>/<sub>2</sub> in.)
- Cylindrical and made of borosilicate glass vessel.
  - max. thickness: 3 mm
  - outside diameter: approx. 190mm
  - height: approx. 90mm
- Glass thermometer: 100°C or 212°F (1 deg scale)

## MICROWAVE LEAKAGE TEST

### CAUTIONS

- Be sure to check microwave leakage prior to servicing the oven if the oven is operative prior to servicing.
- The service personnel should inform the manufacture importer, or assembler of any certified oven unit found to have a microwave emission level in excess of 5 mW/cm<sup>2</sup> and should repair any unit found to have excessive emission levels at no cost to the owner and should ascertain the cause of the excessive leakage. The service personnel should instruct the owner not to use the unit until the oven has been brought into compliance.
- If the oven operates with the door open, the service personnel should:
  - Tell the user not to operate the oven.
  - Contact the manufacturer.
- The service personnel should check all surface and vent openings for microwave leakage.
- Check for microwave leakage after every servicing. The power density of the microwave radiation leakage emitted by the microwave oven should not exceed 4 mW/cm<sup>2</sup>. Always start measuring of an unknown field to assure safety for operating personnel from radiation leakage.

### MEASURING MICROWAVE ENERGY LEAKAGE

- Pour 275±15cc of 20±5°C(68±9°F) water in a beaker which is graduated to 600 cc, and place the beaker on the center of the turntable.
- Set the energy leakage monitor to 2450 MHz and use it following the manufacturer's recommended test procedure to assure correct result.
- When measuring the leakage, always use the 2-inch (5cm) spacer supplied with the probe.
- Operate the oven at its maximum output.
- Measure the microwave radiation using and electromagnetic radiation monitor by holding the probe perpendicular to the surface being measured

Move probe along shaded area

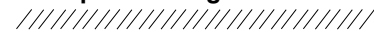

Probe scanning speed

Less than 2.5 cm/sec

( 1in/sec)

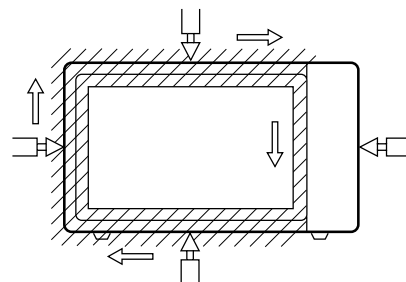

## **MEASUREMENT WITH OUTER CASE REMOVED**

- When you replace the magnetron, measure for microwave energy leakage before the outer case is installed and after all necessary components are replaced or adjusted.  
Special care should be taken in measuring the following parts. (Circled area of below Fig.)
  - Around the magnetron
  - The waveguide

**WARNING : AVOID CONTACTING ANY HIGH VOLTAGE PARTS**

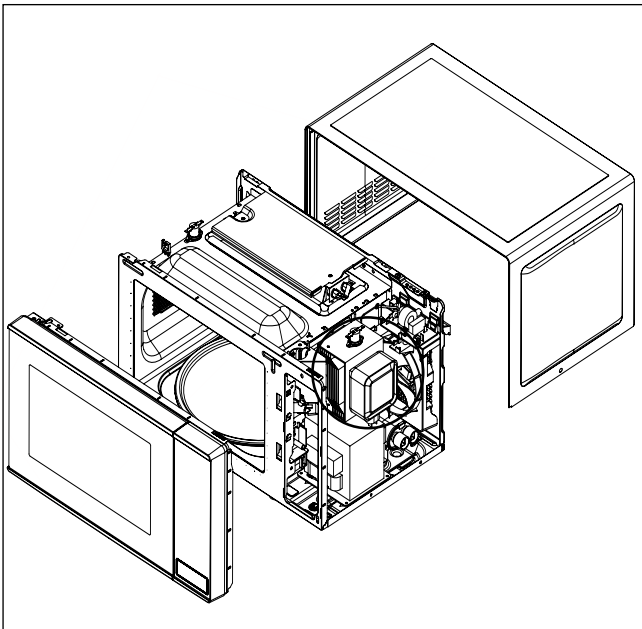

## **MEASUREMENT WITH A FULLY ASSEMBLED OVEN**

- After all components, including the outer case, are fully assembled, measure for microwave energy leakage around the door viewing window, the exhaust opening, and air inlet openings.
- Microwave energy leakage must not exceed the values prescribed below.

**NOTE:** Leakage with the outer case removed less than 5 mW/cm<sup>2</sup>.sq. Leakage for a fully assembled oven (Before the latch switch (primary) is interrupted) with the door in a slightly opened position less than 2 mW/cm<sup>2</sup>.sq.

## **NOTES WHEN MEASURING**

- Do not exceed meter full scale deflection.
- The test probe must be removed no faster than 1 inch/sec (2.5 cm/sec) along the shaded area, otherwise a false reading may result.
- The test probe must be held with the grip portion of the handle.  
A false reading may result if the operator's hand is between the handle and the probe.
- When testing near a corner of the door, keep the probe perpendicular to the surface making sure the probe horizontally along the oven surface, this may possibly cause probe damage.

## **RECORD KEEPING AND NOTIFICATION AFTER MEASUREMENT**

- After adjustment and repair of any microwave energy interruption or microwave energy blocking device, record the measured values for future reference. Also enter the information on the service invoice.
- The microwave energy leakage should not be more than 4 mW/cm<sup>2</sup>.sq. after determining that all parts are in good condition, functioning properly and genuine replacement parts which are listed in this manual have been used.
- At least once a year, have the electromagnetic energy leakage monitor checked for calibration by its manufacturer.

# MEASUREMENT OF MICROWAVE POWER OUTPUT

- Microwave power output measurement is made with the microwave oven supplied at its rated voltage and operated at its maximum microwave power setting with a load of (1000±5) g of potable water.
- The water is contained in a cylindrical borosilicate glass vessel having a maximum material thickness of 3 mm and an outside diameter of approximately 190mm.
- The oven and the empty vessel are at ambient temperature prior to the start of the test.
- The initial temperature (T1) of the water is (10±2)°C. It is measured immediately before the water is added to the vessel. After addition of the water to the vessel, the load is immediately placed on the center of the turntable which is in the lowest position and the microwave power switched on.
- The time T for the temperature of the water to rise by a value ΔT of (10±2)°K is measured, where T is the time in seconds and ΔT is the temperature rise. The initial and final water temperatures are selected so that the maximum difference between the final water temperature and the ambient temperature is 5°K.
- The microwave power output P in watts is calculated from the following formula :

$$P = \frac{4187 \times (\Delta T) + 0.55 \times (T_2 - T_0) \times M}{T}$$

- T<sub>2</sub>: Temperature after heating
- T<sub>0</sub>: Temperature of bowl
- M: Weight of bowl

is measured while the microwave generator is operating at full power. Magnetron filament heat-up time is not included. (about 3 sec)

- The water is stirred to equalize temperature throughout the vessel, prior to measuring the final water temperature.
- Stirring devices and measuring instruments are selected in order to minimize addition or removal of heat.

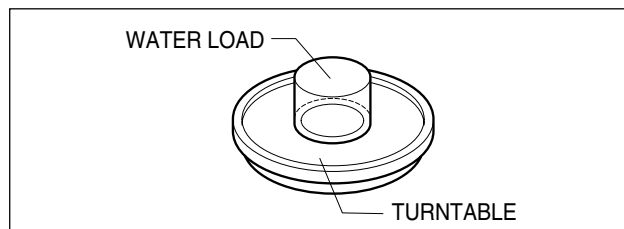

## NOTES:

For simple tests of microwave power output, conduct it by heating one litre water for one minute, minimum temperature rise should be 6 °C

## DISASSEMBLY AND ADJUSTMENT

### A. OUTER CASE REMOVAL

- 1) Disconnect the power supply cord from the outlet.
- 2) Remove the screws from the rear and along side edges of the case.  
The outer case must be moved backward to be lifted off.

### B. POWER SUPPLY CORD

- 1) Remove the outer case.
- 2) Disconnect two terminals, and remove one screw of the earth terminal.

**CAUTION: DISCHARGE THE HIGH VOLTAGE CAPACITOR BEFORE SERVICING**

(refer to page 2-1)

### C. CONTROL PANEL ASSEMBLY

- 1) Disconnect the leadwire from the PCB SUB ASS'Y.
- 2) Remove the screws for the earth and securing the control panel.
- 3) Lift control panel ASS'Y from the oven by the tab unhooked.

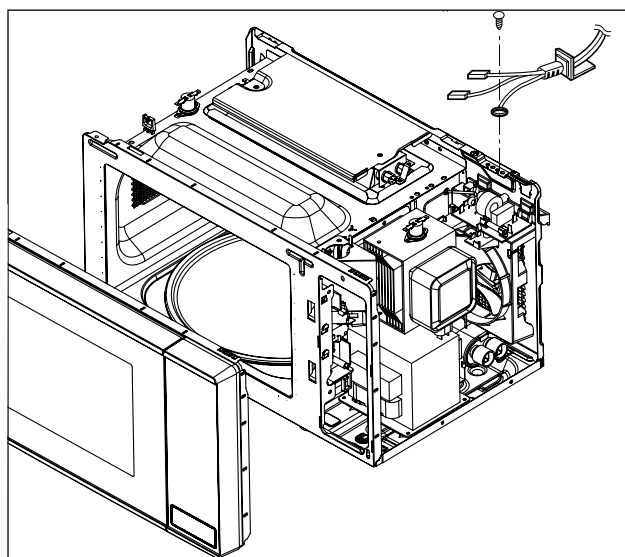

## D. DOOR ASSEMBLY REMOVAL

- 1) Open the door.
- 2) Remove two screws holding the Hinge to the Cavity Ass'y.

**CAUTION : Be careful not to damage Door C by screwdriver.**

- 3) Lift up and pull the door.

### NOTE:

1. After replacing the door, be sure to check that the primary switch, monitor switch, and secondary switch operate normally.
2. After replacing the door, check for microwave energy leakage with a survey meter. Microwave energy must be below the limit of 5 mW/cm<sup>2</sup>. (with a 275 ml water load)
3. When mounting the door assembly to the oven assembly, be sure to adjust the door assembly parallel to the chassis. Also adjust so the door has no play between the inner door surface and oven frame assembly. If the door assembly is not mounted properly, microwaves may leak from the clearance between the door and the oven.

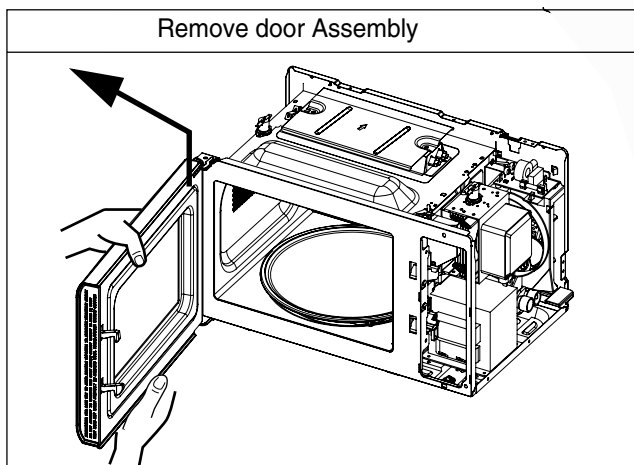
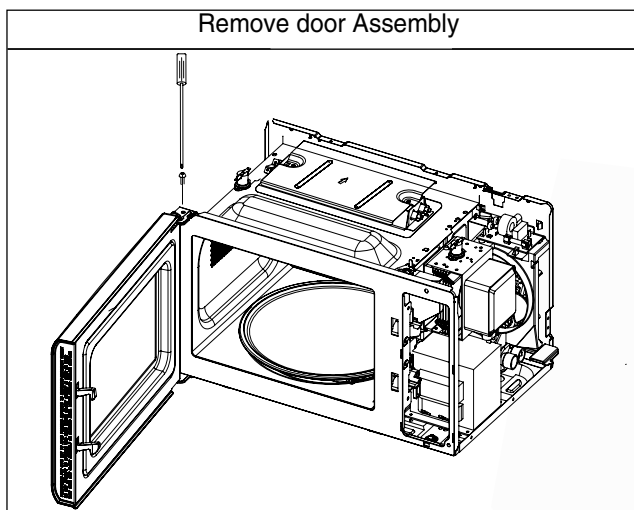

## E. HIGH VOLTAGE TRANSFORMER REMOVAL

- 1) Discharge the high voltage capacitor.
- 2) Disconnect the leadwire from magnetron, high voltage transformer, and capacitor.
- 3) Remove the screw holding the high voltage transformer to the baseplate.

## F. ORIFICE ASSEMBLY REMOVAL

- 1) Discharge the high voltage capacitor.
- 2) Disconnect the leadwire from fan motor, noise filter and high voltage capacitor.
- 3) Remove the two screws holding the orifice ASS'Y to the oven cavity and remove the high voltage diode earth screw.
- 4) Remove the screw of the capacitor bracket.
- 5) Remove the two screws holding the fan motor ASS'Y to the Orifice ASS'Y.

## G. HIGH VOLTAGE CAPACITOR AND DIODE REMOVAL

- 1) Discharge the high voltage capacitor.
- 2) Disconnect the leadwire from fan motor, noise filter and high voltage capacitor.
- 3) Remove the screw holding the Orifice ASS'Y to the oven cavity and remove the high voltage diode earth screw.
- 4) Remove the screw holding the high voltage capacitor bracket.

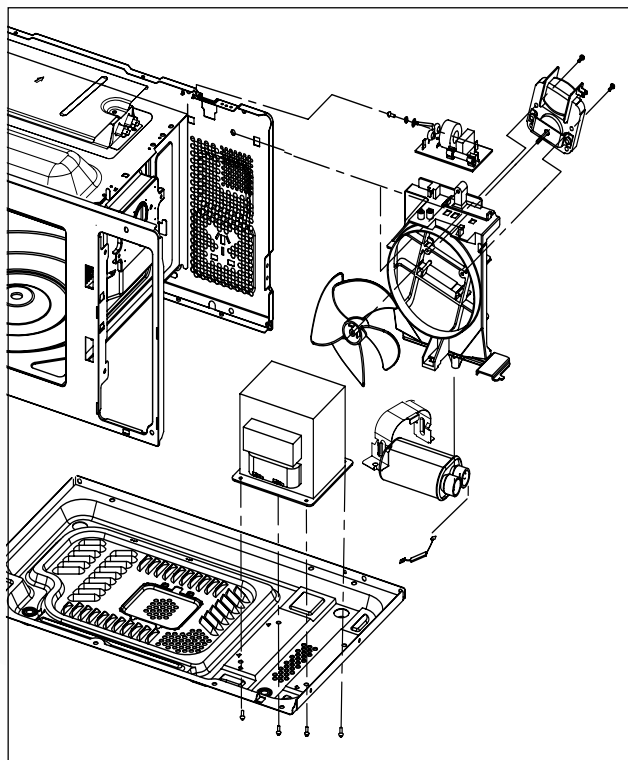

## H. AIR GUIDE ASSEMBLY REMOVAL

- 1) Disconnect the leadwire from lamp, A.C Relay and monitor resistor and magnetron.
- 2) Remove the screw to the cavity.

## I. MAGNETRON REMOVAL

- 1) Disconnect the leadwire from the high voltage transformer and high voltage capacitor.
- 2) Remove the air guide.
- 3) Carefully remove the mounting screws holding the magnetron and the waveguide.
- 4) Remove the magnetron until the tube is clear from the waveguide.

### NOTE:

1. When removing the magnetron, make sure its dome does not hit any adjacent parts, or it may be damaged.
2. When replacing the magnetron, be sure to install the magnetron gasket in the correct position and **be sure that the gasket is in good condition.**
3. After replacing the magnetron, check for microwave leakage with a survey meter around the magnetron. Microwave energy must be below the limit of 5 mW/cm<sup>2</sup>. (With a 275 ml. water load).  
**Make sure that gasket is rigidly attached to the magnetron.** To prevent microwave leakage, tighten the mounting screws properly, making sure there is no gap between the waveguide and the magnetron.

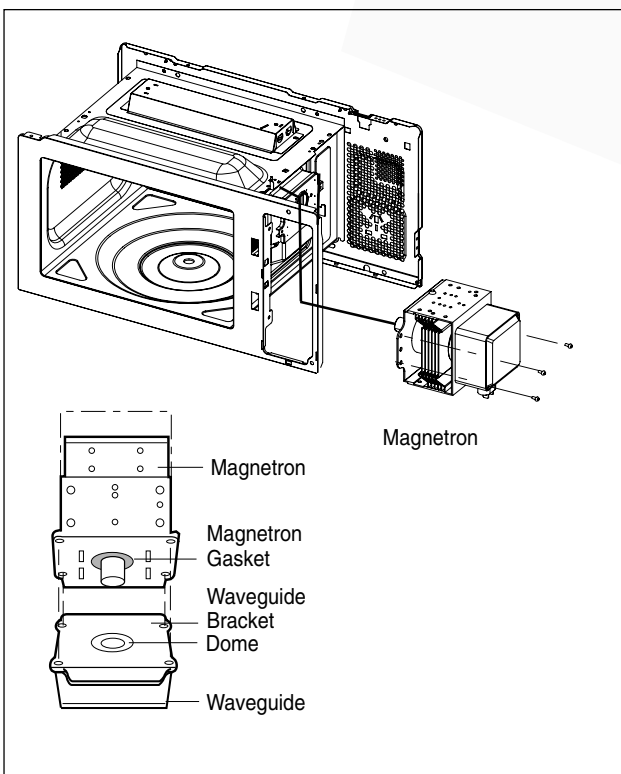

## J. REMOVING THE TURNTABLE MOTOR

- 1) Remove the glass tray.
- 2) Remove the pulley shaft **VERY CAREFULLY**
- 3) Lay the unit down on its back.
- 4) Remove the turntable motor cover.  
The turntable base cover is easily removed by pinching the six parts with a wire cutting.
- 5) Disconnect the leadwire from the turntable motor terminals.
- 6) Remove the screw securing the turntable motor to the oven cavity ASS'Y
- 7) After replacing the motor, rotate the removed turntable motor cover.
- 8) Fit the turntable motor cover's projecting part to the base plate slit.

### NOTE:

1. Remove the wire lead from the turntable motor **VERY CAREFULLY.**
2. Be sure to grasp the connector, not the wires, when removing

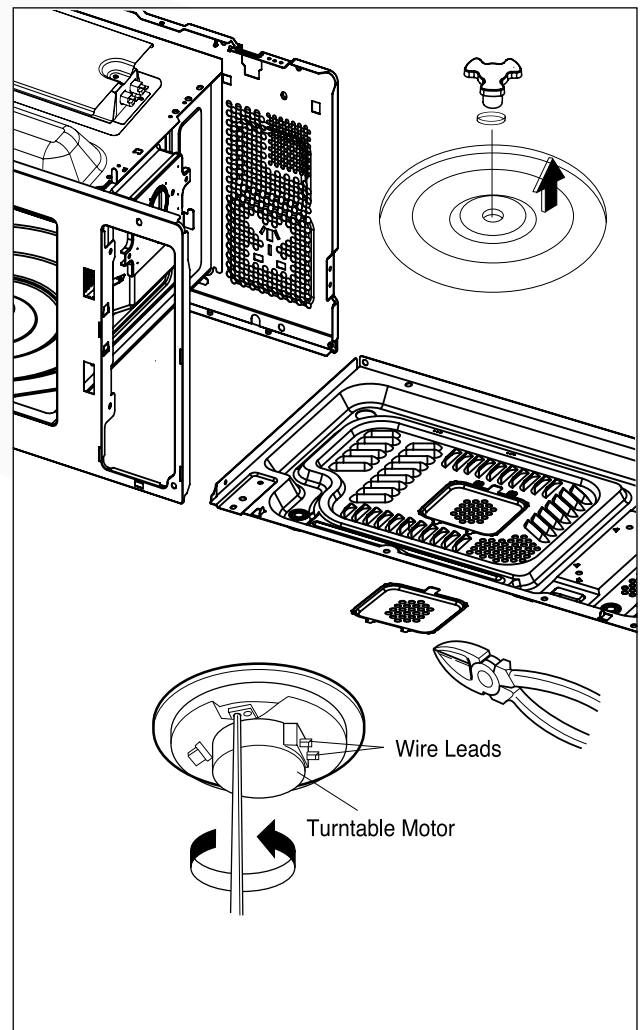

## K. TIMER MOTOR REMOVAL

- 1) Remove the control panel assembly from the cavity.
- 2) Remove screws which hold the timer motor to the control panel.
- 3) Remove the timer motor from the control panel.
- 4) Remove the power control knob and the timer knob.

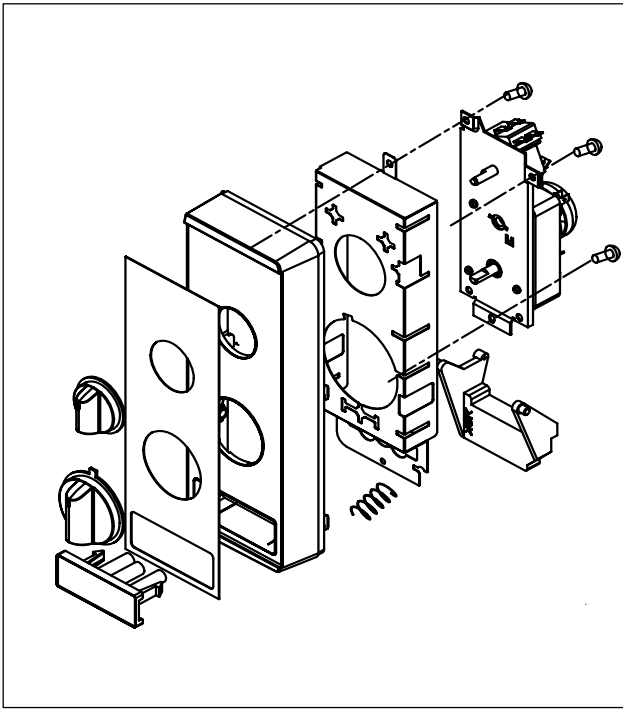

## L. INTERLOCK SYSTEM

### 1) INTERLOCK MECHANISM

The door lock mechanism is a device which has been specially designed to eliminate completely microwave activity when the door is opened during cooking and thus to prevent the danger resulting from the microwave leakage.

### 2) MOUNTING OF THE PRIMARY/MONITOR/SECONDARY SWITCHES TO THE LATCH BOARD

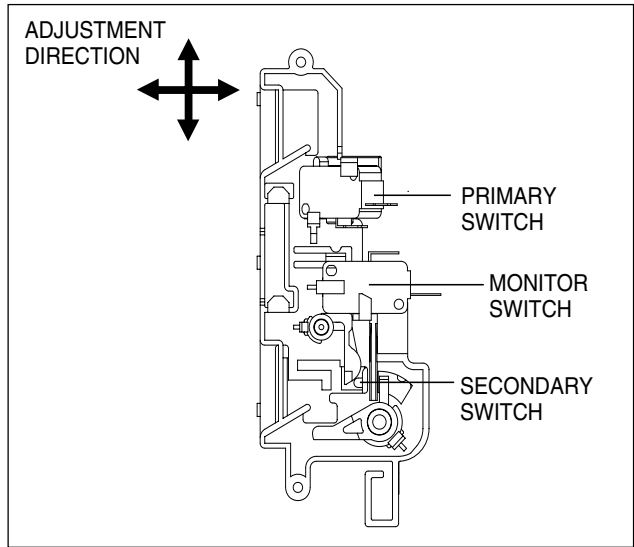

### 3) INSTALLATION AND ADJUSTMENT OF THE LATCH BOARD TO THE OVEN ASSEMBLY

- Mount the latch board to the oven assembly.
- Adjust the latch board in the arrow direction so that oven door will not have any play in it when the door is closed.
- Tighten the mounting screw.
- **Check for play in the door by pushing the door release button. Door movement should be less than 0.5 mm. (1/64 inch)**

Don't push the door release button while making adjustment. Make sure that the latch moves smoothly after adjustment are completed and that the screws are tight. Make sure the primary, monitor, and secondary switches operate properly by following the continuity test procedure.

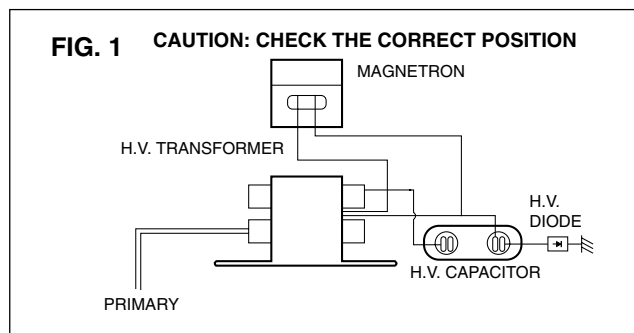



# INTERLOCK CONTINUITY TEST

**WARNING : FOR CONTINUED PROTECTION AGAINST EXCESSIVE RADIATION EMISSION, REPLACE ONLY WITH IDENTICAL REPLACEMENT PARTS.**

TYPE NO. KW3A FOR SWITCHS

## A. PRIMARY INTERLOCK SWITCH TEST

When the door release button is depressed slowly with the door closed, an audible **click** should be heard at the same time or successively at intervals. When the button is released slowly, the latches should activate the switches with an audible **click**.

If the latches do not activate the switches when the door is closed, the switches should be adjusted in accordance with the adjustment procedure. Disconnect the wire lead from the primary switch. Connect the ohmmeter leads to the common (COM) and normally open (NO) terminal of the switch. The meter should indicate an open circuit in the door open condition. When the door is closed, the meter should indicate a closed circuit.

When the primary switch operation is abnormal, make the necessary adjustment or replace the switch only with the same type of switch.

## B. SECONDARY INTERLOCK SWITCH TEST

Disconnect the wire lead from the secondary switch.

Connect the ohmmeter leads to the common (COM) and normally open (NO) terminals of the switch. The meter should indicate a open circuit in the door open condition. When the door is closed, meter should indicate an closed circuit. When the secondary switch operation is abnormal, make the necessary adjustment or replace the switch only with the same type of switch.

## C. MONITOR SWITCH TEST

Disconnect the wire lead from the monitor switch. Connect the ohmmeter leads to the common (COM) and normally closed (NC) terminals of the switch. The meter should indicate closed circuit in the door open condition. When the door is closed, meter should indicate an open circuit. When the monitor switch operation is abnormal, replace with the same type of switch.

**NOTE: After repairing the door or the interlock system, it is necessary to do this continuity test before operating the oven.**

COMPONENTS	TEST PROCEDURE		RESULTS	
			Door open	Door closed
SWITCHES (Wire leads removed)	Check for continuity of the switch with an Ohm-meter			
	Primary Switch Type No.KW3A			
	Monitor Switch Type No.KW3A			
	Secondary Switch Type No.KW3A			
<b>NOTE :</b> After checking for the continuity of switches, make sure that are correctly connected.				



# COMPONENT TEST PROCEDURE

## CAUTIONS

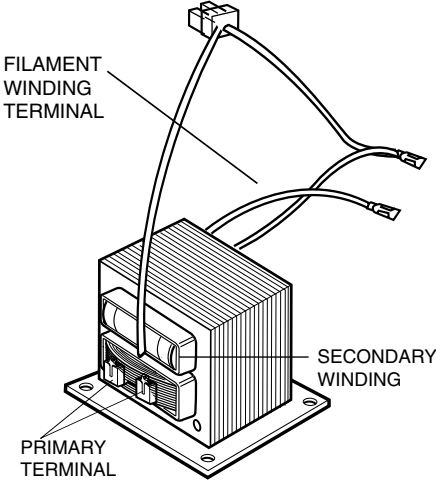
1. DISCONNECT THE POWER SUPPLY CORD FROM THE OUTLET WHENEVER REMOVING THE OUTER CASE FROM THE UNIT. PROCEED WITH THE TEST ONLY AFTER DISCHARGING THE HIGH VOLTAGE CAPACITOR AND REMOVING THE WIRE LEADS FROM THE PRIMARY WINDING OF THE HIGH VOLTAGE TRANSFORMER. (SEE PAGE 2-1)
2. ALL OPERATIONAL CHECKS WITH MICROWAVE ENERGY MUST BE DONE WITH A LOAD (1 LITER OF WATER IN CONTAINER) IN THE OVEN.

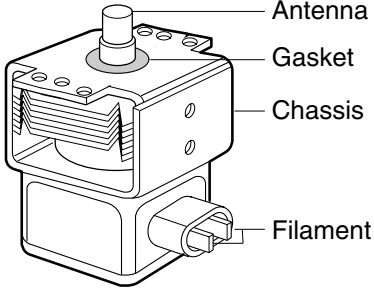
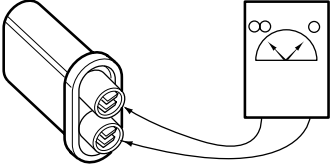
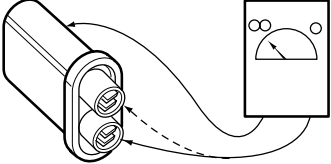
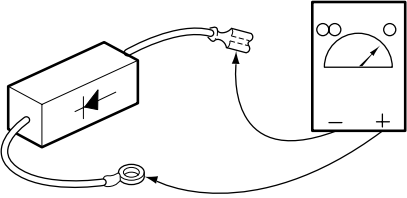
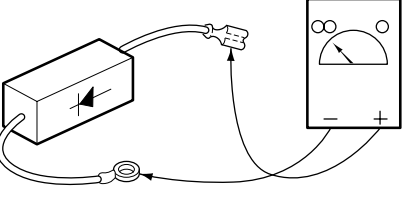
COMPONENTS	TEST PROCEDURE	RESULTS
<p>HIGH VOLTAGE TRANSFORMER (Wire leads removed)</p>	 <p>1. Measure the resistance. (Ohm-meter scale: Rx1)</p> <ul style="list-style-type: none"> <li>• Primary winding</li> <li>• Secondary winding</li> <li>• Filament winding</li> </ul> <p>2. Measure the resistance. (Ohm-meter scale: Rx1000)</p> <ul style="list-style-type: none"> <li>• Primary winding to ground</li> <li>• Filament winding to ground</li> </ul>	<p>Approx.: 1.4 ohm Approx.: 90 ohm Less than: 1 ohm</p> <p>Normal: Infinite Normal: Infinite</p>
<p>MAGNETRON (Wire leads removed)</p>	<p>1. Measure the resistance. (Ohm-meter scale: Rx1)</p> <ul style="list-style-type: none"> <li>• Filament terminal</li> </ul> <p>2. Measure the resistance. (Ohm-meter scale: Rx1000)</p> <ul style="list-style-type: none"> <li>• Filament to chassis</li> </ul>	<p>Normal: Less than 1 ohm</p> <p>Normal: Infinite</p>

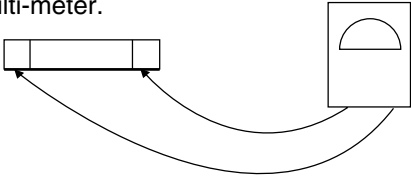
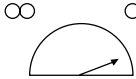
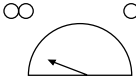
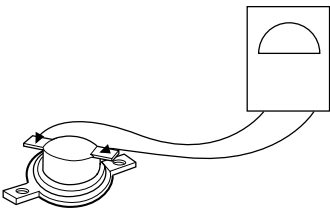
COMPONENTS	TEST PROCEDURE	RESULTS
	 <p>NOTE: When testing the magnetron, be sure to install the magnetron gasket in the correct position and be sure that the gasket is in good condition.</p>	
HIGH VOLTAGE CAPACITOR	<p>Measure the resistance. (Ohm-meter scale: Rx1000)</p> <ul style="list-style-type: none"> <li>Terminal to terminal.</li> </ul> 	Normal: Momentarily indicates several ohms, and then gradually returns to 10M ohms.
	<p>Measure the resistance. (Ohm-meter scale: Rx1000)</p> <ul style="list-style-type: none"> <li>Terminal to case.</li> </ul> 	Normal: ∞
HIGH VOLTAGE DIODE	<p>Measure the continuity (Forward). (Ohm-meter scale: Rx10000)</p> 	Normal: Continuity. Abnormal: ∞ *
*NOTE : Some inexpensive meters may indicate infinite resistance in both direction.	<p>Measure the continuity (Reverse). (Ohm-meter scale: Rx10000)</p> 	Normal: ∞ Abnormal: Continuity.

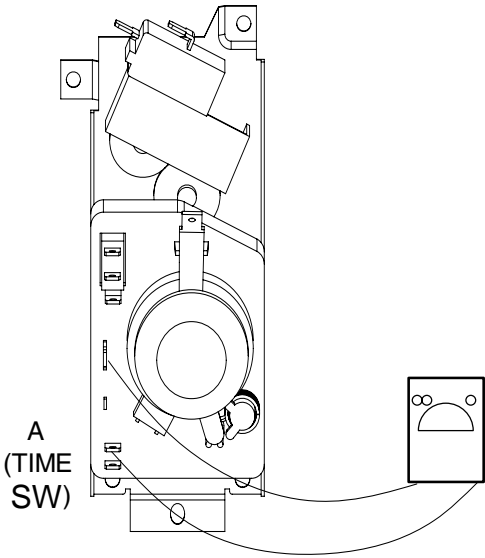
COMPONENTS	TEST PROCEDURE	RESULTS	
FUSE	<p>Check for continuity of the fuse with an multi-meter.</p> 	Normal	Abnormal
<p>NOTE: If the fuse is blown, check the primary, the secondary, and the monitor switches, H.V.D. and H.V.C. before replacing the fuse. If the fuse is blown by improper switch operation replace the defective switch and the fuse at the same time. Replace just the fuse if the switches operate normally.</p>			
THERMAL CUT-OUT		Below specified temperature	Above specified temperature
 		<p>Normal: Approx. 10~30K <math>\Omega</math> Abnormal: <math>\infty</math> or several <math>\Omega</math></p> <p>Note: A is TIME S/W and microwave ON/OFF</p>	
TIMER MOTOR (Wire leads removed)	<p>Measure the resistance. (Ohm-meter scale: R x 1000)</p>  <p>A (TIME SW)</p>	<p>Normal: Approx. 10~30K <math>\Omega</math> Abnormal: <math>\infty</math> or several <math>\Omega</math></p> <p>Note: A is TIME S/W and microwave ON/OFF</p>	

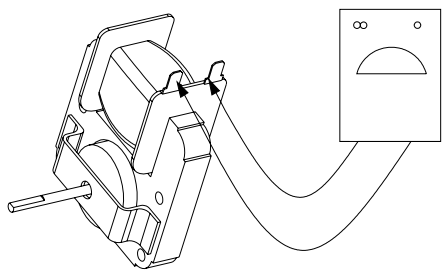
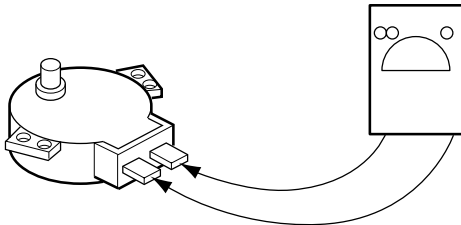
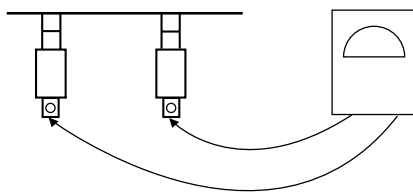
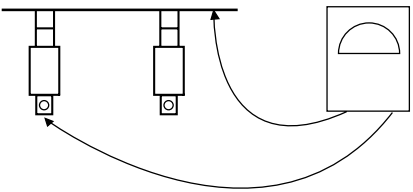
COMPONENTS	TEST PROCEDURE	RESULTS
<p>FAN MOTOR (Wire leads removed)</p>	<p>Measure the resistance. (Ohm-meter scale: R x 100)</p> 	<p>Normal: 100~500 Ω Abnormal: ∞ or several Ω</p>
<p>TURNTABLE MOTOR (Wire leads removed)</p>	<p>Measure the resistance. (Ohm-meter scale: R x 1000)</p> 	<p>Normal: Approx. 100~200 K Ω Abnormal: ∞</p>
<p>HEATER ELEMENT (Wire leads removed.)</p>	<p>Measure the resistance. (Multi-meter scale: Rx1)</p> 	<p>Normal: *Grill heater Approx. 54 Ω (at 20 ~ 30°C)</p>
	<p>Measure the resistance with 500V-100M ohm insulation resistance meter.</p> 	<p>Normal: more than 0.5 Meg Ω</p>
<p>NOTE: Make sure heater is fully cooled when tested.</p>		

NOTE : • A MICROWAVE LEAKAGE TEST MUST ALWAYS BE PERFORMED WHEN THE UNIT IS SERVICED FOR ANY REASON.

- MAKE SURE THE WIRE LEADS ARE IN THE CORRECT POSITION.
- WHEN REMOVING THE WIRE LEADS FROM THE PARTS, BE SURE TO GRASP THE CONNECTOR, NOT THE WIRES.

# TROUBLE SHOOTING

WHEN YOU GET A COMPLAINT FROM YOUR CUSTOMER, EVALUATE THE COMPLAINT CAREFULLY. IF THE FOLLOWING SYMPTOMS APPLY, PLEASE INSTRUCT THE CUSTOMER IN THE PROPER USE OF THE MICROWAVE OVEN. THIS CAN ELIMINATE AN UNNECESSARY SERVICE CALL.

## CAUTIONS

1. Check grounding before checking for trouble.
  2. Be careful of the high voltage circuit.
  3. Discharge the high voltage capacitor. (See page 2-1)
  4. When checking the continuity of the switches or of the high voltage transformer, disconnect one lead wire from these parts and then check continuity with the AC plug removed. To do otherwise may result in a false reading or damage to your meter.
  5. Do not touch any part of the circuitry on the digital programmer circuit since static electric discharge may damage this control panel.
- Always touch yourself ground while working on this panel to discharge any static charge built up in your body.

CONDITION	CAUSE	REMEDY
Microwave oven does not work.	Inserting many plug into one plug outlet and using them at the same time (causes overloading).	Avoid using other electrical appliances when you use the microwave oven.
	Microwave oven plug is not inserted tightly.	Insert microwave oven plug securely.
Output power is too low.	Low AC input voltage.	Use the microwave oven at adequate line voltage.
	Food temperature is too low.	This may not be a defect. It is possible that the food should be cooked for a longer time period.
Sparks occurring.	Using metallic ware and allowing it to touch the oven wall.	Do not use metallic ware for cooking except where noted in the cooking guide.
	Ceramic ware trimmed in gold or silver powder is used.	Do not use any type of cookware with metallic trimming.
Uneven cooking.	Inconsistent intensity of microwave by their characteristics.	<ol style="list-style-type: none"> <li>1. Wrap the thinner part with aluminum foil.</li> <li>2. Use plastic wrap or lid.</li> <li>3. Stir once or twice while cooking soup, cocoa or milk, etc.</li> </ol>
Turntable drags or makes noise.	Excessive weight on tray or improperly balanced.	Distribute food evenly. Cook smaller portions and, or use lighter weight cookware.

**(TROUBLE 1) Oven lamp does not turn on when the timer is set with door closed.**

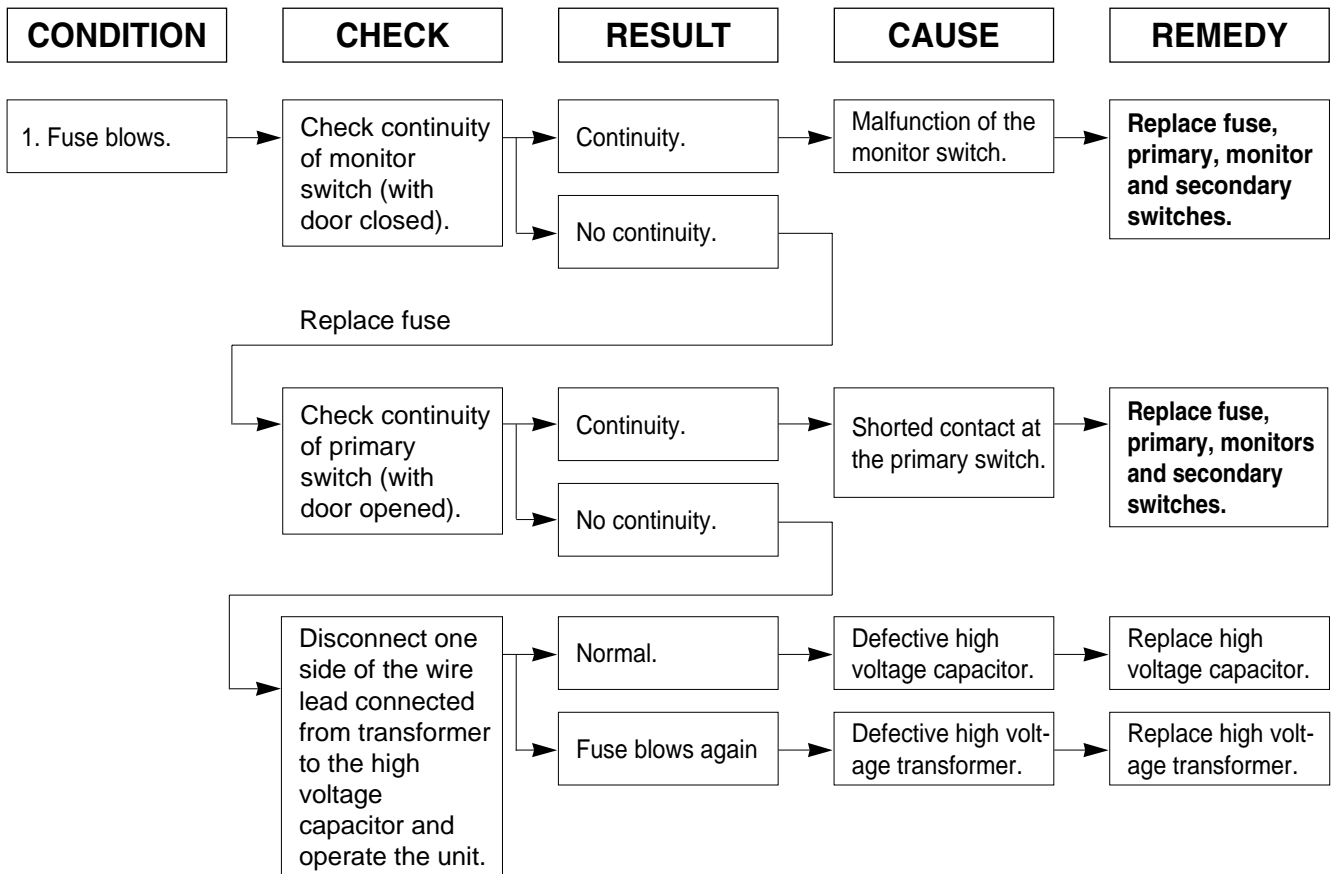

**NOTE : All these switches must be replaced at the same time.**

**(TROUBLE 2) Oven does not start even though the timer is set.**

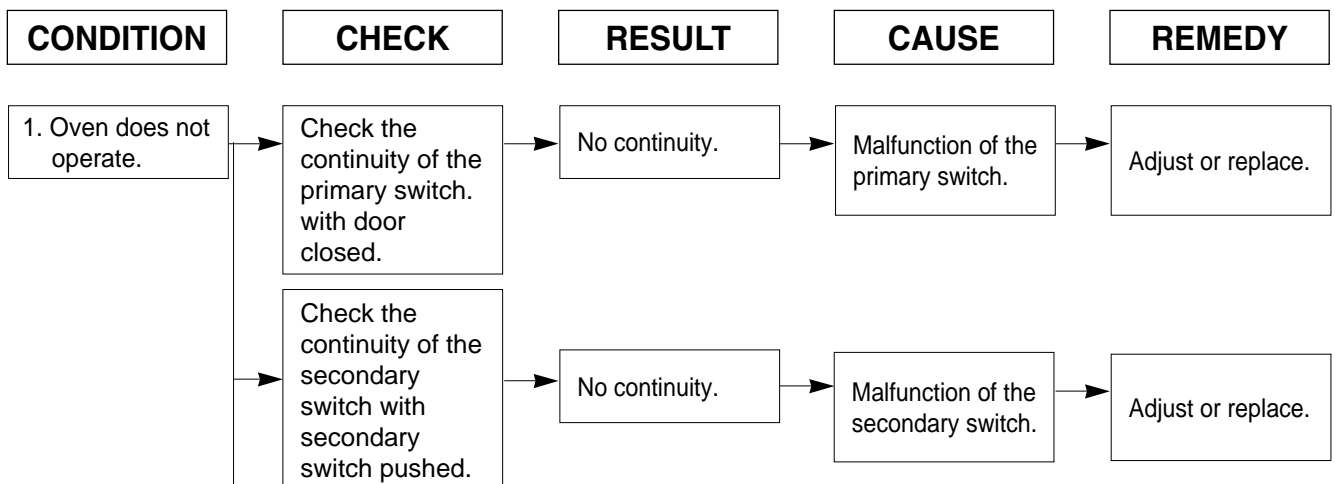

CONDITION	CHECK	RESULT	CAUSE	REMEDY
	Check the continuity of the timer switch contacts.	No continuity.	Malfunction of the timer switch.	replace.
	Check the continuity of the thermostat.	No continuity.	Faulty thermostat.	replace.

**(TROUBLE 3) Output power is low.**

CONDITION	CHECK	RESULT	CAUSE	REMEDY
Output is low	Check the power source voltage oscillating.	Lower than 198V.	Decrease in power source voltage with load.	Suggest customer contact local electric power utility co. or qualified electrician.
		Normal		
	Measure the magnetron's output(See test procedure).	Less than 6° C.	Faulty magnetron.	

**(TROUBLE 4) Grill.**

CONDITION	CHECK	RESULT	CAUSE	REMEDY
1. Heater is not operating.	Heater.	Abnormal.	Malfunction the heater.	Replace.
		Normal.		
	Thermostat (Grill)	Abnormal.	Malfunction the thermostat.	Replace.
		Normal.		
	Wire connection.	No continuity.	Open or loosen.	Replace.



**(TROUBLE 5) Oven does not cook at all even though turntable rotates.**

CONDITION	CHECK	RESULT	CAUSE	REMEDY
No microwave oscillation.	Check the power control switch(cooking state).	No continuity.	Malfunction of the power control switch.	Replace the power control switch.
		Continuity.		
	Check the monitor resistor.	Abnormal or burn out.	Defective monitor resistor.	Replace.
	Check the AC relay.	Abnormal	Defective AC relay.	Replace.
		Normal		
	Check H.V. transformer.	Abnormal	Open the secondary winding of the high voltage transformer of faulty insulation of filament winding.	Replace.
	Check H.V. diode.	Abnormal	Shorted H.V diode.	Replace.
	Check H.V. capacitor.	Abnormal	Faulty capacitor.	Replace.
	Magnetron.	Abnormal	Faulty magnetron.	Replace.

# EXPLODED VIEW

## INTRODUCTION

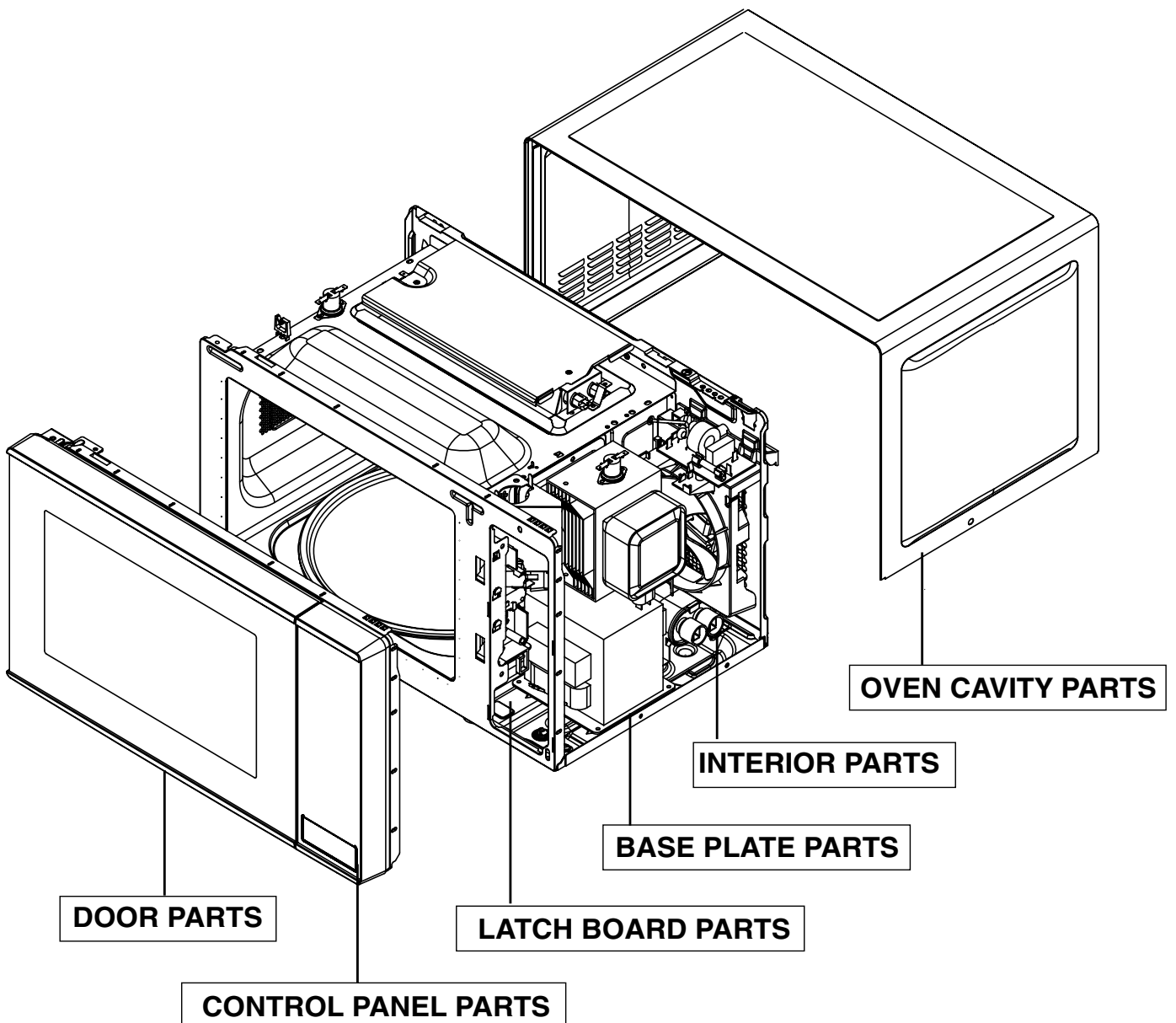

# DOOR PARTS

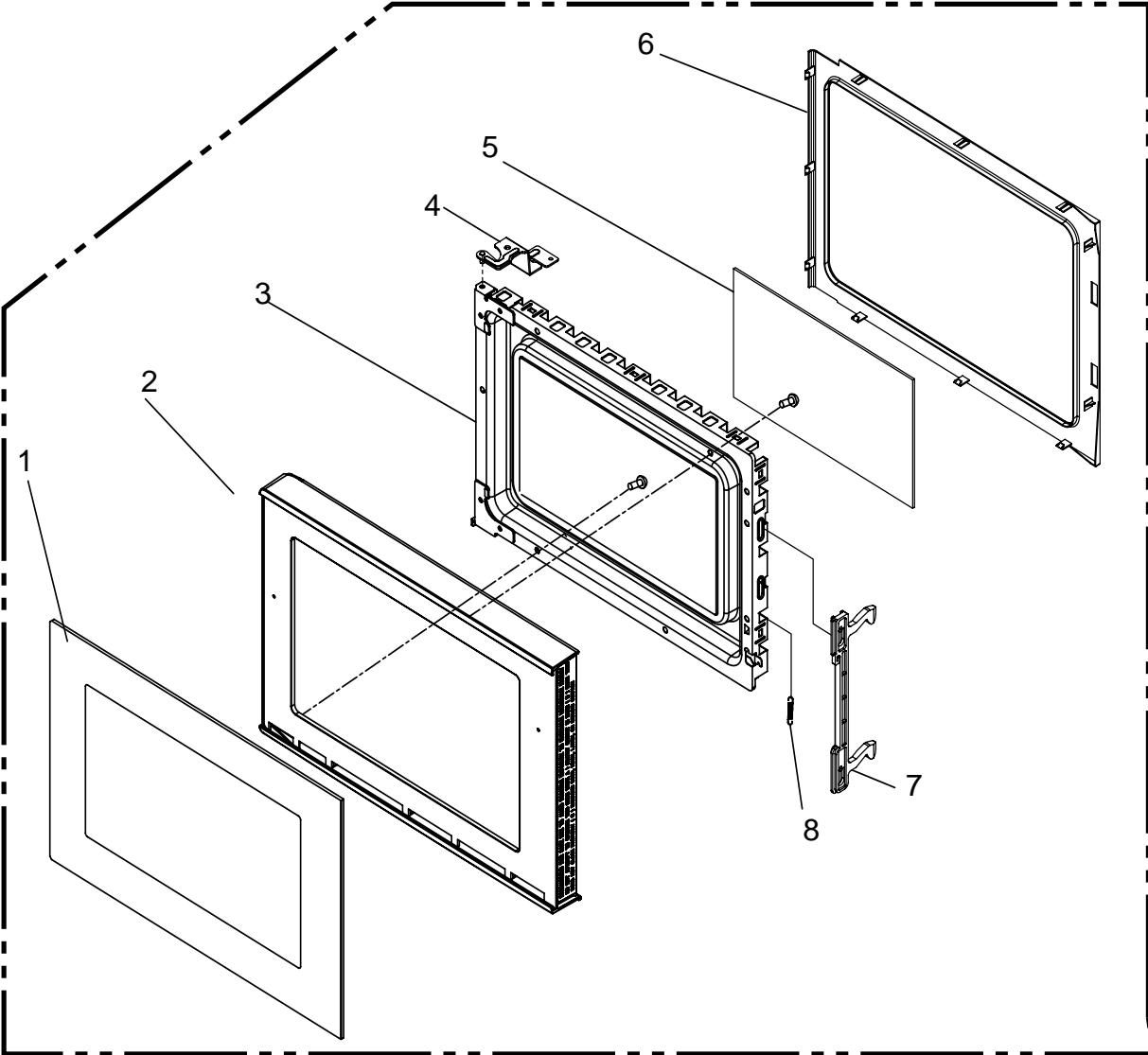

# CONTROL PANEL PARTS

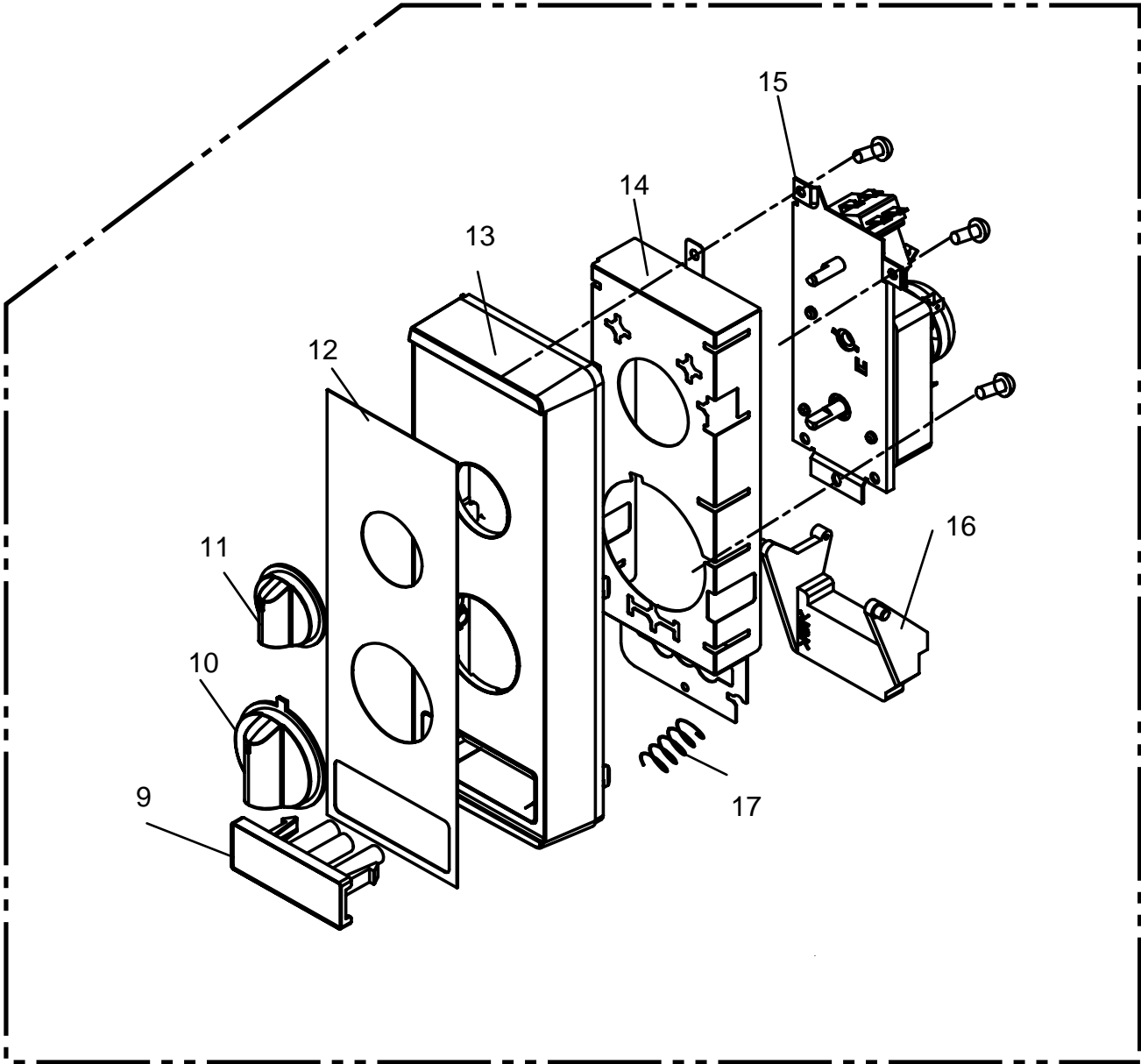



# LATCH BOARD PARTS

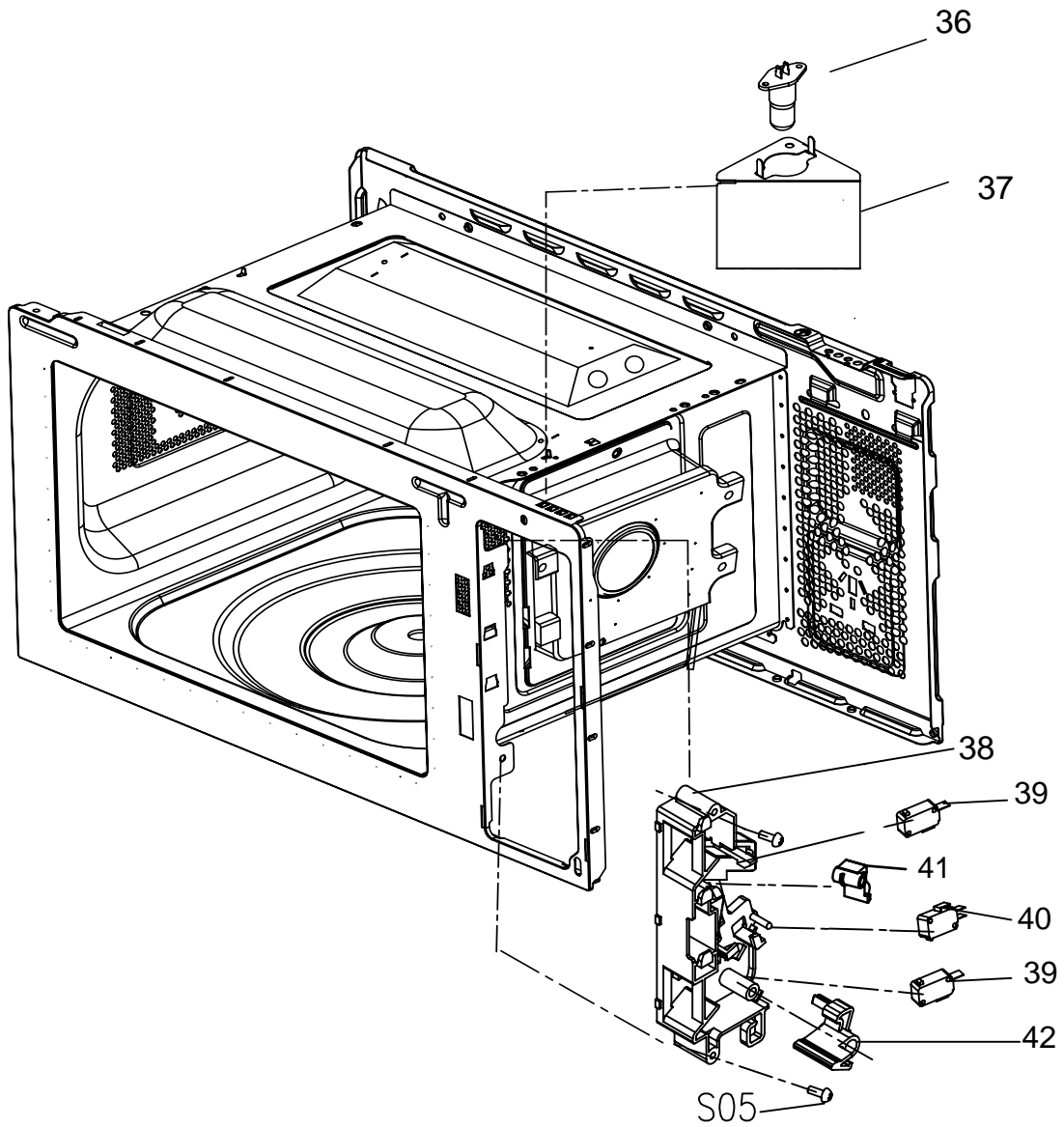

# INTERIOR PARTS

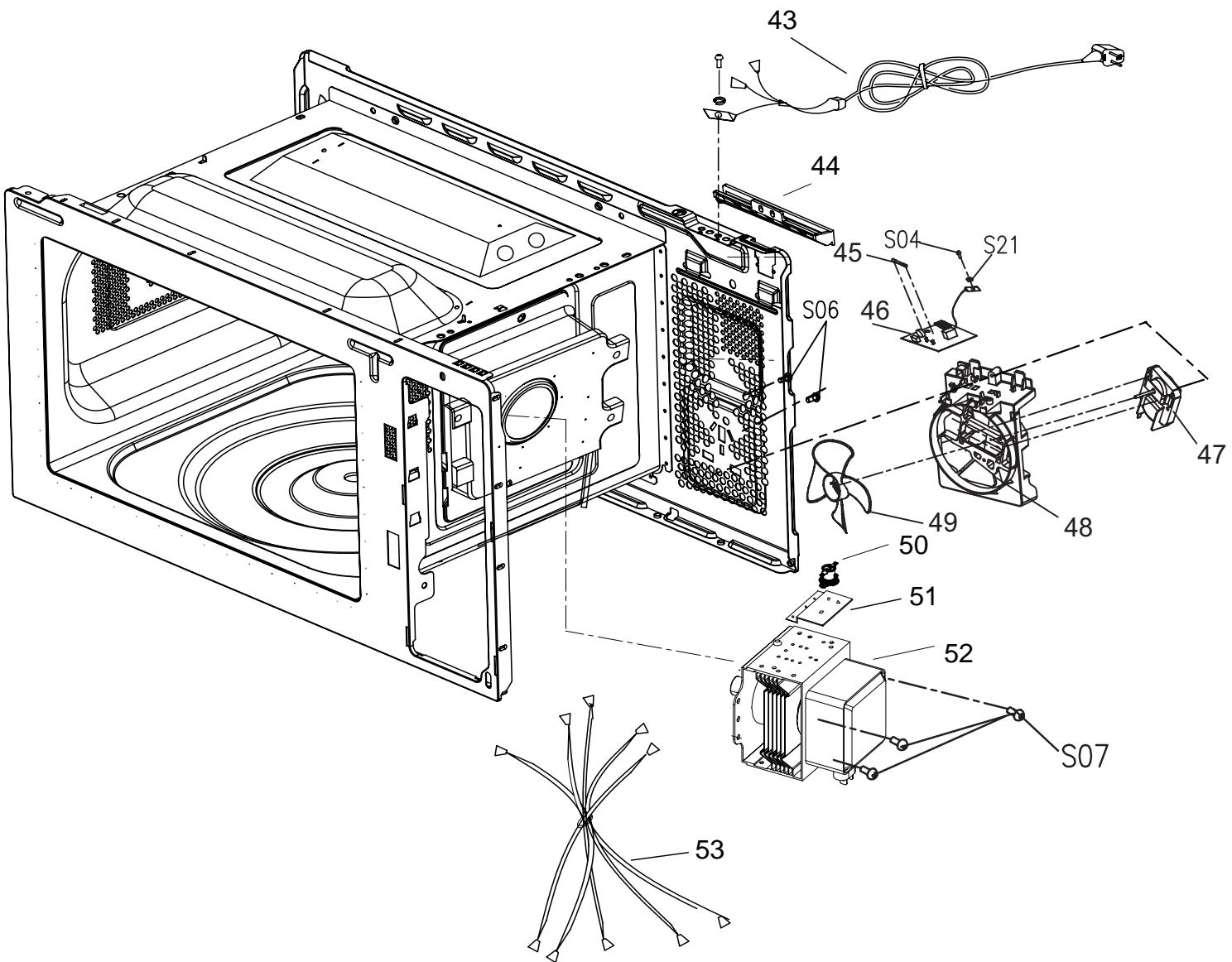

# BASE PLATE PARTS

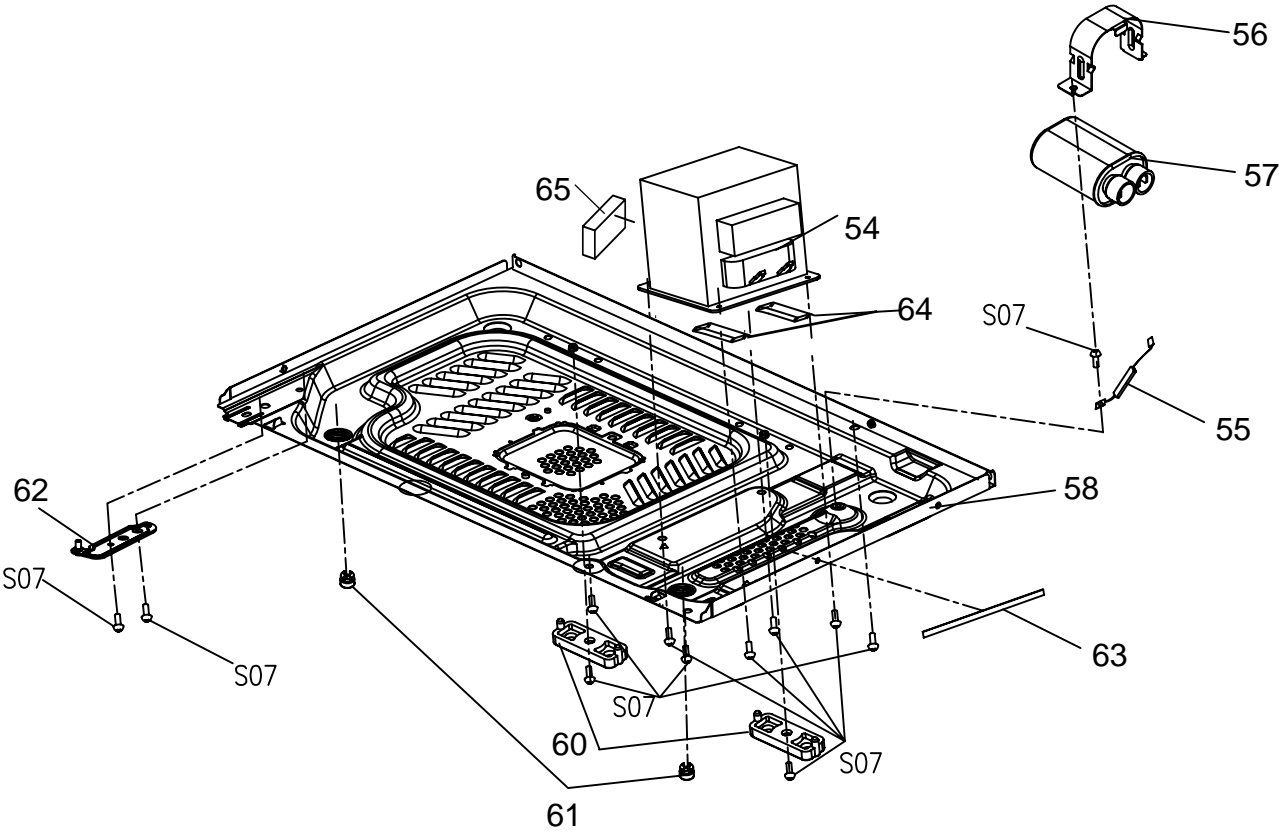



## REPLACEMENT PARTS LIST

**NOTE:**

1. When ordering replacement part(s), please use part number(s) shown in this part list.

Do not use description of the part.

2. Important safety notice:

Components identified by  mark have special characteristics important for safety.

When replacing any of these components, use only manufacture's specified parts.

**For Model:NN-GM231W(ZPE)**

Ref.No.	Safty	Part No.	Part Name&Description	Pcs/Set	Remarks
1		A314640L0HZP	DOOR SCREEN B	1	White
2		A300140N0HBP	DOOR A	1	White
3+5		A302K7W50BP	DOOR E (U)	1	
4		A31767W50BP	TOP DOOR HINGE	1	
5		A31457W50BP	DOOR SCREEN A	1	
6		A30857W50BP	DOOR C	1	
7		A30187W50BP	DOOR KEY A	1	
8		A32307W50BP	DOOR KEY SPRING	1	
9		A807240L0HZP	DOOR OPENING BUTTON (U)	1	
10		A802040L0HZP	TIMER KNOB	1	Power
11		A803940L0HZP	TIMER KNOB A	1	Timer
12		A833740M0HZP	DECO. MEMBRANE	1	White
13		A803440M0HZP	ESCUTCHEON BASE	1	White
14		A812740M0BP	BACK PLATE	1	
15		A60017W50BP	TIMER SWITCH	1	
16		A82567W50BP	DOOR OPENING LEVER	1	
17		A80377W50BP	SPRING	1	For DOOR OPEN BUTTON
18		A91697W50BP	WIRE HOLDER	1	
19		A61457W50BP	THERMAL CUTOUT	1	155°C
20		A290D40L0TU	ROLLER RING (U)	1	D16
21		A060140L0TU	COOKING TRAY	1	D255
22		A06027W50BP	WIRE RACK	1	
23		A64607W50BP	BRACKET , HEATER	1	
24		A64177W50BP	HEATER SUPPORT A	1	
25		A66797W50BP	HEATER COVER A	1	
27		A631E40M0ZP	HEATER	2	220V
28		A66267W50BP	BRACKET. TERMAL CUTOUT	1	
29		A65677W60BP	THERMAL CUTOUT	1	70°C , HEATER
30		A110D40N0HBP	CABINET BODY (U)	1	
32		A205540M0BP	CEILING COVER	1	

## REPLACEMENT PARTS LIST

33		A213140N0BP	PULLEY SHAFT	1	
35		A63267W50BP	TURNTABLE MOTOR	1	
36		A612E7W50BP	LAMP (U)	1	
37		A402540N0BP	AIR GUIDE A	1	
38	⚠	A302040N0BP	DOOR HOOK A	1	
39	⚠	A61417W50BP	MICROSWITCH	2	MAINARY / SECONDARY
40	⚠	A61427W50BP	MICROSWITCH	1	MONITOR
41		A313640N0BP	HOOK SPACER A	1	
42		A313740N0BP	HOOK SPACER B	1	
43	⚠	A900C7W50EP	AC CORD W/PLUG	1	
44		A488540N0BP	BRACKET WATER SEALING	1	
45	⚠	A623040N0BP	FUSE	1	8A
46	⚠	A692Y40M0ZP	NOISE FILTER	1	
47		A400A7W50BP	FAN MOTOR	1	
48		A41447W50BP	ORIFICE	1	
49		A40087W50BP	FAN BLADE	1	
50	⚠	A64487W50BP	THERMAL CUTOUT	1	MAGNETRON
51		A61647W50BP	BRACKET TERMAL CUTOUT	1	
52	⚠	2M219J	MAGNETRON	1	
53		A030A40M0ZP	HARNESS , MAIN	1	
54	⚠	A600B7W50ZP	H.V.TRANSFORMER	1	For 220V
55	⚠	A62027W50BP	DIODE,SI	1	
56		A618840N0BP	BRACKET , CAPACITOR	1	
57	⚠	A60907W50BP	H.V. CAPACITOR	1	For 220/230V
58		A100140MOBP	BASE	1	
60		A10947W50BP	RUBBER FOOT B	2	
61		A10087W50BP	RUBBER FOOT	2	
62		A30077W50BP	LOWER HINGE	1	
63		A09047W50BP	CUSHION RUBBER	1	For BASE
64		J09087W50BP	CUSHION RUBBER	2	Under H.V.TRANSFORMER
65		A09097W50BP	CUSHION RUBBER	1	Side of H.V.TRANSFORMER
66		J09067W50BP	CUSHION RUBBER	1	
67		A217340NOTU	SPACER , TURNTABLE MOTOR	1	
		J09027W50BP	CUSHION RUBBER	1	65*120*3mm, CABINET BODY
		A000340M0ZP	OPERATING INSTRUCTION	1	

**Panasonic<sup>®</sup>**

P/NO :

Jul, 2011  
Printed in China