

# Service Manual



## Mono Laser MFP

SCX-3200/3205

SCX-3205W

The keynote of Product

1. Print / Copy Speed
  - 17 ppm in letter
2. Processor
  - Jupiter5 375 Mhz
3. Printer Language Emulations
  - SPL, PCL5e
4. Memory
  - 32 MB (SCX-3200/3205)
  - 128 MB (SCX-3205W)
5. Interfaces
  - One USB port
  - One 10/100 Base TX network connector (SCX-3205W)
  - One 802.11b/g/n wireless module (SCX-3205W)
6. Toner cartridge
  - Initial : 700 pages
  - Sales : 1,500 pages
7. Machine life
  - 30,000 sheets or 3 years (whichever comes first)



**ELECTRONICS**

*Service Manual*

*Service Manual*

GSPN (Global Service Partner Network)

North America : [service.samsungportal.com](http://service.samsungportal.com)

Latin America : [latin.samsungportal.com](http://latin.samsungportal.com)

CIS : [cis.samsungportal.com](http://cis.samsungportal.com)

Europe : [europe.samsungportal.com](http://europe.samsungportal.com)

China : [china.samsungportal.com](http://china.samsungportal.com)

Asia : [asia.samsungportal.com](http://asia.samsungportal.com)

Mideast & Africa : [mea.samsungportal.com](http://mea.samsungportal.com)

© Samsung Electronics Co.,Ltd. February. 2010  
Printed in Korea.

**VERSION NO. : 1.00    CODE : 3200-00000E**

## *chapter 1 Precautions*

1.1 Safety Warning .....	1-1
1.2 Caution for safety .....	1-2
1.2.1 Toxic material.....	1-2
1.2.2 Electric Shock and Fire Safety Precautions .....	1-2
1.2.3 Handling Precautions .....	1-3
1.2.4 Assembly / Disassembly Precautions .....	1-3
1.2.5 Disregarding this warning may cause bodily injury .....	1-4
1.3 ESD Precautions .....	1-5

## *chapter 2 Product Overview*

2.1 Product Specifications .....	2-1
2.1.1 Product Overview .....	2-1
2.1.2 Specifications.....	2-2
2.1.3 Model Comparison Table.....	2-11
2.2 System Overview .....	2-12
2.2.1 Front View .....	2-12
2.2.2 Rear View .....	2-13
2.2.3 System Layout .....	2-14
2.2.4 Engine H/W Specifications .....	2-21
2.2.5 Engine F/W Control Algorithm .....	2-27
2.2.6 S/W Descriptions .....	2-29

## *chapter 3 Maintenance and Disassembly*

3.1 Precautions when replacing parts .....	3-1
3.1.1 Precautions when assembling and disassembling .....	3-1
3.1.2 Precautions when handling PBA .....	3-1
3.1.3 Releasing Plastic Latches .....	3-1

---

3.2 Screws used in the printer .....	3-2
3.3 Left / Right cover .....	3-3
3.4 Scanner unit .....	3-4
3.4.1 OPE unit .....	3-5
3.4.2 CIS unit .....	3-6
3.4.3 Scan motor .....	3-7
3.5 Middle cover and COVER-OPEN .....	3-9
3.6 Front and Rear cover .....	3-10
3.7 Main PBA .....	3-10
3.8 SMPS / HVPS board .....	3-11
3.9 Fuser unit .....	3-12
3.10 LSU .....	3-13
3.11 Drive unit .....	3-14
3.12 Step motor .....	3-15
3.13 Pick up roller .....	3-16
3.14 Transfer roller .....	3-17

## *chapter 4* Alignment and Troubleshooting

4.1 Alignment and Adjustments.....	4-1
4.1.1 Control Panel.....	4-1
4.1.2 Understanding the status LED .....	4-2
4.1.3 JAM Removal .....	4-3
4.1.4 EDC mode .....	4-6
4.1.5 Tech mode .....	4-9
4.1.6 Upgrade Firmware .....	4-17
4.1.7 Periodic Defective Image.....	4-21
4.2 Troubleshooting.....	4-22
4.2.1 Procedure of Checking the Symptoms .....	4-22
4.2.2 Error code and troubleshooting .....	4-23
4.2.3 Printing quality problems .....	4-44
4.2.4 Copy Problems .....	4-58
4.2.5 Scan problems .....	4-62
4.2.6 Other errors .....	4-64

---

## *chapter 5* *System Diagram*

5.1 Block Diagram .....	5-1
5.2 Connection Diagram.....	5-2

## *chapter 6* *Reference Information*

6.1 Tool for Troubleshooting .....	6-1
6.2 Acronyms and Abbreviations .....	6-2
6.2.1 Acronyms .....	6-2
6.2.2 Service Parts .....	6-4
6.3 A4 ISO 19798 Standard Pattern.....	6-8
6.3.1 A4 ISO 19752 Standard Pattern .....	6-8
6.4 Selecting a location .....	6-9

## *attached* *Exploded Views & Parts List*

# 1. Precautions

In order to prevent accidents and damages to the equipment please read the precautions listed below carefully before servicing the product and follow them closely.

## 1.1 Safety warning

(1) Only to be serviced by a factory trained service technician.

High voltages and lasers inside this product are dangerous. This product should only be serviced by a factory trained service technician.

(2) Use only Samsung replacement parts.

There are no user serviceable parts inside the product. Do not make any unauthorized changes or additions to the product as these could cause the product to malfunctions and create an electric shocks or fire hazards.

(3) Laser Safety Statement

The product is certified in the U.S. to conform to the requirements of DHHS 21 CFR, chapter 1 Subchapter J for Class 1(1) laser products, and elsewhere, it is certified as a Class I laser product conforming to the requirements of IEC 825. Class I laser products are not considered to be hazardous. The laser system and product are designed so there is never any human access to laser radiation above a Class I level during normal operation, user maintenance, or prescribed service condition.

**Warning >> Never operate or service the product with the protective cover removed from Laser/Scanner assembly. The reflected beam, although invisible, can damage your eyes. When using this product, these basic safety pre-cautions should always be followed to reduce risk of fire, electric shock, and personal injury.**



CAUTION - INVISIBLE LASER RADIATION  
WHEN THIS COVER OPEN.  
DO NOT OPEN THIS COVER.

VORSICHT - UNSICHTBARE LASERSTRAHLUNG,  
WENN ABDECKUNG GE...FFNET.  
NICHT DEM STRAHL AUSSETZEN.

ATTENTION - RAYONNEMENT LASER INVISIBLE EN CAS  
D'OUVERTURE. EXPOSITION DANGEREUSE  
AU FAISCEAU.

ATTENZIONE - RADIAZIONE LASER INVISIBLE IN CASO DI  
APERTURA. EVITARE L'ESPOSIZIONE AL  
FASCIO.

PRECAUCION - RADIACION LASER IVISIBLE CUANDO SE ABRE.  
EVITAR EXPONERSE AL RAYO.

ADVARSEL - USYNLIG LASERSTRLNING VED BNING, NR  
SIKKERHEDSBRYDERE ER UDE AF FUNKTION.  
UNNG UDSAETTEELSE FOR STRLNING.

ADVARSEL - USYNLIG LASERSTRLNING NR DEKSEL  
PNES. STIRR IKKE INN I STRLEN.  
UNNG EKSPONERING FOR STRLEN.

VARNING - OSYNLIG LASERSTRLNING NR DENNA DEL  
R...PPNAD OCH SPRREN R URKOPPLAD.  
BETRAKTA EJ STRLEN. STRLEN R FARLIG.

VARO! - AVATTAESSA JA SUOJALUKITUS OHITETTAESSA  
OLET ALTIINA NKYMTT...MLLE LASER-  
STEILYLLE L KATSO STEESEEN.

注 意 - 严禁揭开此盖, 以免激光泄露灼伤

주 의 - 이 덮개를 열면 레이저광에 노출될 수 있으므로  
주의하십시오.

## 1.2 Caution for safety

---

### 1.2.1 Toxic material

---

This product contains toxic materials that could cause illness if ingested.

- (1) If the LCD control panel is damaged, it is possible for the liquid inside to leak. This liquid is toxic. Contact with the skin should be avoided. Wash any splashes from eyes or skin immediately and contact your doctor. If the liquid gets into the mouth or is swallowed, see a doctor immediately.
- (2) Please keep imaging unit and toner cartridge away from children. The toner powder contained in the imaging unit and toner cartridge may be harmful, and if swallowed, you should contact a doctor.

### 1.2.2 Electric shock and fire safety precautions

---

Failure to follow the following instructions could cause electric shock or potentially cause a fire.

- (1) Use only the correct voltage, failure to do so could damage the product and potentially cause a fire or electric shock.
- (2) Use only the power cable supplied with the product. Use of an incorrectly specified cable could cause the cable to overheat and potentially cause a fire.
- (3) Do not overload the power socket, this could lead to overheating of the cables inside the wall and could lead to a fire, and/or cause your ceiling or lamp lights to flicker.
- (4) Do not allow water or other liquids to spill into the product, this can cause electric shock. Do not allow paper clips, pins or other foreign objects to fall into the product, these could cause a short circuit leading to an electric shock or fire hazard.
- (5) Never touch the plugs on either end of the power cable with wet hands, this can cause electric shock. When servicing the product, remove the power plug from the wall socket.
- (6) Use caution when inserting or removing the power connector. When removing the power connector, grip it firmly and pull. The power connector must be inserted completely, otherwise a poor contact could cause overheating possibly leading to a fire.
- (7) Take care of the power cable. Do not allow it to become twisted, bent sharply around corners or wise damaged. Do not place objects on top of the power cable. If the power cable is damaged it could overheat and cause a fire. Exposed cables could cause an electric shock. Replace the damaged power cable immediately, do not reuse or repair the damaged cable. Some chemicals can attack the coating on the power cable, weakening the cover or exposing cables causing fire and shock risks.
- (8) Ensure that the power sockets and plugs are not cracked or broken in any way. Any such defects should be repaired immediately. Take care not to cut or damage the power cable or plugs when moving the machine.
- (9) Use caution during thunder or lightning storms. Samsung recommends that this machine be disconnected from the power source when such weather conditions are expected. Do not touch the machine or the power cord if it is still connected to the wall socket in these weather conditions.
- (10) Avoid damp or dusty areas, install the product in a clean well ventilated location. Do not position the machine near a humidifier or in front of an air conditioner. Moisture and dust built up inside the machine can lead to overheating and cause a fire or cause parts to rust.
- (11) Do not position the product in direct sunlight. This will cause the temperature inside the product to rise possibly leading to the product failing to work properly and in extreme conditions could lead to a fire.
- (12) Do not insert any metal objects into the machine through the ventilator fan or other part of the casing, it could make contact with a high voltage conductor inside the machine and cause an electric shock.

### 1.2.3 Handling precautions

---

The following instructions are for your own personal safety to avoid injury and so as not to damage the product.

- (1) Ensure the product is installed on a level surface, capable of supporting its weight. Failure to do so could cause copy quality problems, and/or the product to tip or fall.
- (2) The product contains many rollers, gears and fans. Take great care to ensure that you do not catch your fingers, hair or clothing in any of these rotating devices.
- (3) Do not place any small metal objects, containers of water, chemicals or other liquids close to the product which if spilled could get into the machine and cause damage or a shock or fire hazard.
- (4) Do not install the machine in areas with high dust or moisture levels, beside an open window or close to a humidifier or heater. Damage could be caused to the product in such areas.
- (5) Do not place candles, burning cigarettes, etc on the product, These could cause a fire.

### 1.2.4 Assembly / Disassembly precautions

---

Replace parts carefully and always use Samsung parts. Take care to note the exact location of parts and also cable routing before dismantling any part of the machine. Ensure all parts and cables are replaced correctly. Please carry out the following procedures before dismantling the product or replacing any parts.

- (1) Check the contents of the machine memory and make a note of any user settings. These will be erased if the main board or network card is replaced.
- (2) Ensure that power is disconnected before servicing or replacing any electrical parts.
- (3) Disconnect interface cables and power cables.
- (4) Only use approved spare parts. Ensure that part number, product name, any voltage, current or temperature rating are correct.
- (5) When removing or re-fitting any parts do not use excessive force, especially when fitting screws into plastic.
- (6) Take care not to drop any small parts into the machine.
- (7) Handling of the OPC Drum
  - The OPC Drum can be irreparably damaged if it exposed to light. Take care not to expose the OPC Drum either to direct sunlight or to fluorescent or incandescent room lighting. Exposure for as little as 5 minutes can damage the surface of the photoconductive properties and will result in print quality degradation. Take extra care when servicing the product. Remove the OPC Drum and store it in a black bag or other lightproof container. Take care when working with the Covers (especially the top cover) open as light is admitted to the OPC area and can damage the OPC Drum.
  - Take care not to scratch the green surface of OPC Drum Unit. If the green surface of the Drum Cartridge is scratched or touched the print quality will be compromised.



### **1.2.5 Disregarding this warning may cause bodily injury**

---

- (1) Be careful with the high temperature part.  
The fuser unit works at a high temperature. Use caution when working on the printer. Wait for the fuser to cool down before disassembly.
- (2) Do not put finger or hair into the rotating parts.  
When operating a printer, do not put hand or hair into the rotating parts (Paper feeding entrance, motor, fan, etc.). If done, you can get harmed.
- (3) When you move the printer.  
This printer weighs 4.72kg (10.41 lbs) including toner cartridge and cassette. Use safe lifting and handling techniques. Use the lifting handles located on each side of the machine. Back injury could be caused if you do not lift carefully.
- (4) Ensure the printer is installed safely.  
The printer weighs 4.72kg (10.41 lbs), ensure the printer is installed on a level surface, capable of supporting its weight. Failure to do so could cause the printer to tip or fall possibly causing personal injury or damaging the printer.
- (5) Do not install the printer on a sloping or unstable surface. After installation, double check that the printer is stable.

## 1.3 ESD precautions

Certain semiconductor devices can be easily damaged by static electricity. Such components are commonly called “Electrostatically Sensitive (ES) Devices” or ESDs. Examples of typical ESDs are: integrated circuits, some field effect transistors, and semiconductor “chip” components.

The techniques outlined below should be followed to help reduce the incidence of component damage caused by static electricity.

*Caution >>Be sure no power is applied to the chassis or circuit, and observe all other safety precautions.*

1. Immediately before handling a semiconductor component or semiconductor-equipped assembly, drain off any electrostatic charge on your body by touching a known earth ground. Alternatively, employ a commercially available wrist strap device, which should be removed for your personal safety reasons prior to applying power to the unit under test.
2. After removing an electrical assembly equipped with ESDs, place the assembly on a conductive surface, such as aluminum or copper foil, or conductive foam, to prevent electrostatic charge buildup in the vicinity of the assembly.
3. Use only a grounded tip soldering iron to solder or desolder ESDs.
4. Use only an “anti-static” solder removal device. Some solder removal devices not classified as “anti-static” can generate electrical charges sufficient to damage ESDs.
5. Do not use Freon-propelled chemicals. When sprayed, these can generate electrical charges sufficient to damage ESDs.
6. Do not remove a replacement ESD from its protective packaging until immediately before installing it. Most replacement ESDs are packaged with all leads shorted together by conductive foam, aluminum foil, or a comparable conductive material.
7. Immediately before removing the protective shorting material from the leads of a replacement ESD, touch the protective material to the chassis or circuit assembly into which the device will be installed.
8. Maintain continuous electrical contact between the ESD and the assembly into which it will be installed, until completely plugged or soldered into the circuit.
9. Minimize bodily motions when handling unpackaged replacement ESDs. Normal motions, such as the brushing together of clothing fabric and lifting one’s foot from a carpeted floor, can generate static electricity sufficient to damage an ESD.

## 2. Product spec and feature

### 2.1 Product Specifications

#### 2.1.1 Product Overview



**SCX-3200/3205  
SCX-3205W**

1. Print / Copy Speed
  - 17 ppm in letter
2. Processor
  - Jupiter5 375 Mhz
3. Printer Language Emulations
  - SPL, PCL5e
4. Memory
  - 32 MB (SCX-3200/3205)
  - 128 MB (SCX-3205W)
5. Interfaces
  - One USB port
  - One 10/100 Base TX network connector (SCX-3205W)
  - One 802.11b/g/n wireless module (SCX-3205W)
6. Toner cartridge
  - Initial : 700 pages
  - Sales : 1,500 pages
7. Machine life
  - 30,000 sheets or 3 years (whichever comes first)

## 2.1.2 Specifications

- Product Specifications are subject to change without notice. See below for product specifications.

### 2.1.2.1 General Specification

Items		SCX-3200/3205	SCX-3205W
Major Functions	Standard	- Copy - Print - Scan	- Copy - Print & N/W Print - Scan - Wireless LAN - DLNA
	Option	-	-
Dimension (WxDxH)		15.28 x 11.77 x 9.21 inches (388 x 299 x 234 mm)	15.28 x 11.77 x 9.21 inches (388 x 299 x 234 mm)
Weight	with Package	7.5 Kg (16.63 lbs)	7.5 Kg (16.63 lbs)
LCD		7-Segment(2-Digit)	7-Segment(2-Digit)
I/O Interface	Standard	Hi-Speed USB 2.0	Hi-Speed USB 2.0, Ethernet 10/100 Base TX (Embedded type) Wireless LAN 802.11 b/g/n
	Option	-	-
Power Consumption	Avg operation	Less than 270 W	Less than 270 W
	Sleep Mode	Less than 3.8 W	Less than 5.6 W
	Standby Mode	Less than 36 W	Less than 36 W
Noise (Sound Pressure)	Operating	Printing : 49dBA Copying : 49dBA	Printing : 49dBA Copying : 49dBA
	Standby	Less than 26 dBA	Less than 26 dBA
Warm Up Time	from Sleep Start	Less than 15 sec	Less than 15 sec
Machine Life	Monthly Duty Cycle	5,000 pages	5,000 pages
	Average Monthly Print Volume	101 pages	101 pages
	Average Monthly Scan Volume	-	-
	Machine Life	Engine :30,000 sheets or 3 years (whichever comes first)	Engine :30,000 sheets or 3 years (whichever comes first)
	ADF Feed Roller	-	-
	ADF Rubber Pad	-	-
	Pick-up Roller	30,000 pages	30,000 pages
	Transfer Roller	30,000 pages	30,000 pages
Fuser Unit	30,000 pages	30,000 pages	
CPU		375 MHz	375 MHz

## 2.1.2.2 Print Specification

Items		SCX-3200/3205	SCX-3205W
Print Speed		Up to 16 ppm in A4 (17 ppm in Letter)	Up to 16 ppm in A4 (17 ppm in Letter)
Print Language (Emulation)		SPL, PCL5e	SPL, PCL5e
Power Save		Yes (1, 5, 10, 15, 20, 30, 45, 60, 120 minutes)	Yes (1, 5, 10, 15, 20, 30, 45, 60, 120 minutes)
Power rating		110 ~ 127 VAC(-10%-6%), 50/60Hz, 4.0A 220 ~ 240 VAC(-10%-6%), 50/60Hz, 2.0A	110 ~ 127 VAC(-10%-6%), 50/60Hz, 4.0A 220 ~ 240 VAC(-10%-6%), 50/60Hz, 2.0A
Resolution		Up to 1200 dpi Effective Output (Addressable 1200 x 1200 dpi)	Up to 1200 dpi Effective Output (Addressable 1200 x 1200 dpi)
Memory		32 MB	128 MB
FPOT		Less than 10 sec (from Ready mode) Less than 30 sec (from Sleep mode)	Less than 10 sec (from Ready mode) Less than 30sec (from Sleep mode)
Duplex Print			
Halftone(Gray Scale)		256 Levels	256 Levels
N/W Print	Compatibility	-	Windows 2000/ XP(32/64bit)/2003(32/64bit)/ Vista(32/64bit)/2008(32/64bit)/ in7(32/64bit)/ 2008R2(64bit) Various Linux OS: - RedHat Enterprise Linux WS 4, 5 (32/64bit) - Fedora Core 2~9 (32/64bit) - Mandriva 2005, 2006, 2007, 2008(32/64bit) - openSuSE 9.1, 9.2, 9.3, 10.0, 10.1, 10.2, 10.3, 11.0 (32bit) - SuSE Linux Enterprise Desktop 9, 10 (32/64bit) - Ubuntu 6.04, 6.10, 7.04, 7.10, 8.04 (32/64bit) - Debian 3.1, 4.0 (32/64bit) Mac OS 10.3~10.6 Unix AT&T system V(Rel 4.2), BSD4.3, HP-UX (Rel 9.x & Rel 10.x), SCO 5.x, SUNOS 5.5, Sparc or Solaris 2.5
	Printing Protocols	-	TCP/IPv4/IPv6, HTTP, SNMPv1/v2c/v3, LDAP, SMTP, Ethertalk
	Novell N/W Print Service	-	Netware 5.x, 6.x (TCP/IP Only)
	Device Discovery	-	Rendezvous(Bonjour), SLP, UPnP

### 2.1.2.3 Scan Specification

Items		SCX-3200/3205	SCX-3205W
Scan Method		Color CIS	Color CIS
Scan Speed	Linearity, Halftone	15 sec (at Pc scan : P4-2.4GHz, 512MB, USB2.0, 300dpi, Letter)	15 sec (at Pc scan : P4-2.4GHz, 512MB, USB2.0, 300dpi, Letter)
	Gray	25 sec (at Pc scan : P4-2.4GHz, 512MB, USB2.0, 300dpi, Letter)	25 sec (at Pc scan : P4-2.4GHz, 512MB, USB2.0, 300dpi, Letter)
	Color	40 sec (at Pc scan : P4-2.4GHz, 512MB, USB2.0, 300dpi, Letter)	40 sec (at Pc scan : P4-2.4GHz, 512MB, USB2.0, 300dpi, Letter)
Resolution	Optical	1200 x 1200 dpi (Color@Platen), 600 x 600 dpi (B/W@Platen)	1200 x 1200 dpi (Color@Platen), 600 x 600 dpi (B/W@Platen)
	Enhanced	4800 x 4800 dpi	4800 x 4800 dpi
Halftone		256 levels	256 levels
Scan Size	Max. Document Width	Max. 216 mm (8.5")	Max. 216 mm (8.5")
	Effective Scan Width	Max. 208 mm (8.2")	Max. 208 mm (8.2")
Scan Depth	Color	Internal: 30 bit, External : 24 bit	Internal: 30 bit, External : 24 bit
	Mono	- 1bit for Lineart & Halftone - 8bits for Gray scale	- 1bit for Lineart & Halftone - 8bits for Gray scale
Scan to	Application	Yes	Yes
	USB	No	No
	Email	No	No
	SMB	No	No
	FTP	No	No
	HTTP(S)	No	No
Scan Manager		Yes	Yes
Network Scan		No	Yes

Items		SCX-3200/3205	SCX-3205W
Compatibility	PC Scan	Windows 2000/ XP(32/64bit)/2003(32/64bit)/ Vista(32/64bit)/2008(32/64bit)/ Win7(32/64bit)/2008R2(64bit) Various Linux OS: - RedHat Enterprise Linux WS 4, 5 (32/64bit) - Fedora Core 2~9 (32/64bit) - Mandriva 2005, 2006, 2007, 2008(32/64bit) - openSuSE 9.1, 9.2, 9.3, 10.0, 10.1, 10.2, 10.3, 11.0 (32bit) - SuSE Linux Enterprise Desktop 9, 10 (32/64bit) - Ubuntu 6.04, 6.10, 7.04, 7.10, 8.04 (32/64bit) - Debian 3.1, 4.0 (32/64bit) Mac OS 10.3~10.6	Windows 2000/ XP(32/64bit)/2003(32/64bit)/ Vista(32/64bit)/2008(32/64bit)/ Win7(32/64bit)/2008R2(64bit) Various Linux OS: - RedHat Enterprise Linux WS 4, 5 (32/64bit) - Fedora Core 2~9 (32/64bit) - Mandriva 2005, 2006, 2007, 2008(32/64bit) - openSuSE 9.1, 9.2, 9.3, 10.0, 10.1, 10.2, 10.3, 11.0 (32bit) - SuSE Linux Enterprise Desktop 9, 10 (32/64bit) - Ubuntu 6.04, 6.10, 7.04, 7.10, 8.04 (32/64bit) - Debian 3.1, 4.0 (32/64bit) Mac OS 10.3~10.6
	Network Scan	None	None

### 2.1.2.4 Copy Specification

Items		SCX-3200/3205	SCX-3205W
Copy Speed	Simplex Copy Speed	@SDMP, Text: Up to 16 cpm (A4) / 17ppm (Ltr) Up to 12 cpm (A4) (For Austria, Belgium, Germany, Spain)	@SDMP, Text: Up to 16 cpm (A4) / 17ppm (Ltr) Up to 12 cpm (A4) (For Austria, Belgium, Germany, Spain)
FCOT		Less than 15 seconds	Less than 15 seconds
Multi Copy		1~99	1~99
Duplex		N/A	N/A
Original Type	Text	Scan: 600x600dpi(Optical 600x300dpi), Printing : 600x600dpi	Scan: 600x600dpi(Optical 600x300dpi), Printing : 600x600dpi
	Text/Photo	Scan: 600x600dpi(Optical 600x300dpi), Printing : 600x600dpi	Scan: 600x600dpi(Optical 600x300dpi), Printing : 600x600dpi
	Photo	Scan: 1200x1200dpi(Optical 600x600dpi), Printing : 1200x1200dpi	Scan: 1200x1200dpi(Optical 600x600dpi), Printing : 1200x1200dpi
Automatic Background Suppression		Off, Auto	Off, Auto
Darkness Control		5 Level	5 Level
Collation Copy		No	No
Special Copy	ID Card Copy	Yes	Yes
	Margin Shift	No	No
	Book Copy	No	No
	Covers	No	No
	Transparencies	No	No
	Create Booklet	No	No
	N-up copy	No	No
	Clone	No	No
	Poster	No	No



### 2.1.2.5 Paper Handling

Items		SCX-3200/3205	SCX-3205W
Input Capacity	Main Tray	150-sheet Cassette @ 80g/m <sup>2</sup>	150-sheet Cassette @ 80g/m <sup>2</sup>
	Manual Tray	1 sheet @ 80g/m <sup>2</sup>	1 sheet @ 80g/m <sup>2</sup>
	Optional Cassette	No	No
Output Capacity		50 sheets @ 80g/m <sup>2</sup> face down	50 sheets @ 80g/m <sup>2</sup> face down
Media Size	Main Tray	A4, A5, Letter, Legal, Executive, Folio, ISO B5, JIS B5, Custom	A4, A5, Letter, Legal, Executive, Folio, ISO B5, JIS B5, Custom
	Manual Tray	A4, A5, Letter, Legal, Executive, Officio, Folio, ISO B5, JIS B5 Envelope Monarch, No.9, No.10, DL, C5 Minimum Size (Custom) : 76x183mm (3x7.2inch) Maximum Size (Custom): 216x356mm (8.5x14inch)	A4, A5, Letter, Legal, Executive, Officio, Folio, ISO B5, JIS B5 Envelope Monarch, No.9, No.10, DL, C5 Minimum Size (Custom) : 76x183mm (3x7.2inch) Maximum Size (Custom): 216x356mm (8.5x14inch)
	Duplex	NA	NA
Media Type	Main Tray	Plain ,Thick, Thin, Recycled, Archive	Plain ,Thick, Thin, Recycled, Archive
	Manual Tray	Plain Paper, Transparency, Envelope, Labels, Card stock	Plain Paper, Transparency, Envelope, Labels, Card stock
	Duplex	NA	NA
Media Weight	Main Tray	16~32lb (60 to 120g/m <sup>2</sup> )	16~32lb (60 to 120g/m <sup>2</sup> )
	Manual Tray	16~43 lb (60 to 163g/m <sup>2</sup> )	16~43 lb (60 to 163g/m <sup>2</sup> )
	Duplex	NA	NA
ADF Capacity		-	-
ADF Document Size		-	-

## 2.1.2.6 Software

Items		SCX-3200/3205	SCX-3205W
OS		Windows 2000/XP(32/64bit)/ 2003(32/64bit)/ Vista(32/64bit)/2008(32/64bit)/ Win7(32/64bit)/2008R2(64bit) Various Linux OS: - RedHat Enterprise Linux WS 4, 5 (32/64bit) - Fedora 4, 5, 6, 7, 8, 9, 10, 11, 12 (32/64bit) - SuSE Linux 10.0, 10.1 (32bit) - OpenSuSE 10.2, 10.3, 11.0, 11.1, 11.2 (32/64bit) - Mandriva 2005, 2006, 2007, 2008, 2009, 2009.1 (32/64bit) - Ubuntu 5.04, 5.10, 6.06, 6.10, 7.04, 7.10, 8.04, 8.10, 9.04, 9.10 (32/64bit) - SuSE Linux Enterprise Desktop 10, 11 (32/64bit) - Debian 4.0, 5.0 (32/64bit)	Windows 2000/XP(32/64bit)/ 2003(32/64bit)/ Vista(32/64bit)/2008(32/64bit)/ Win7(32/64bit)/2008R2(64bit) Various Linux OS: - RedHat Enterprise Linux WS 4, 5 (32/64bit) - Fedora 4, 5, 6, 7, 8, 9, 10, 11, 12 (32/64bit) - SuSE Linux 10.0, 10.1 (32bit) - OpenSuSE 10.2, 10.3, 11.0, 11.1, 11.2 (32/64bit) - Mandriva 2005, 2006, 2007, 2008, 2009, 2009.1 (32/64bit) - Ubuntu 5.04, 5.10, 6.06, 6.10, 7.04, 7.10, 8.04, 8.10, 9.04, 9.10 (32/64bit) - SuSE Linux Enterprise Desktop 10, 11 (32/64bit) - Debian 4.0, 5.0 (32/64bit)
Driver	Printer	SPL, PCL5e	SPL, PCL5e
	TWAIN	Yes	Yes
	WIA	Yes	Yes
	ICDM	Yes	Yes
WHQL		Windows XP, 2003, Vista, 2008, Win7, 2008R2	Windows XP, 2003, Vista, 2008, Win7, 2008R2
Application S/W	SmarThru	SmarThru 4	SmarThru 4
	Smart Panel	Yes (Windows, Mac, Linux)	Yes (Windows, Mac, Linux)
	Printer Settings Utility	Yes (Windows, Mac, Linux)	Yes (Windows, Mac, Linux)
	Network Scan	No	Yes
	Scan Manager	Yes (Windows, Mac)	Yes (Windows, Mac)
	PC-FAX	-	-
	Direct Printing Utility	No	No
Network Application	SWAS	No	SyncThru Web Admin Service 5.0 (Windows)
	SetIP	No	Yes

Items		SCX-3200/3205	SCX-3205W
Accessory	Quick Install Guide	Yes	Yes
	S/W CD ROM	1 CD for all driver & application	1 CD for all driver & application
	Toner Cartridge	1 EA	1 EA
	Power Cable	1 EA	1 EA
	Telephone Jack	No	No
	Wireless Install Guide	No	Yes
	Printer Cable[USB]	Only XBH/ETS/XIP/STS/XEV/XSS model	Only XBH/ETS/XIP/STS/XEV/XSS model

### 2.1.2.7 Options

Items	SCX-3200/3205	SCX-3205W
Options	No	No
Memory	No	No
Paper Cassette	No	No
PS	No	No
Mechanical Counter	No	No
FDI	No	No
Downloadable Font ROM	No	No
2nd Fax Modem	No	No
Desk	No	No



### 2.1.2.8 Consumables

Items		SCX-3200/3205	SCX-3205W
Type		1 piece	1 piece
Model Code	Toner	MLT-D104S, MLT-D104L	MLT-D104S, MLT-D104L
Toner	Life	Standard : Average Cartridge Yield 1,500 standard pages (Ships with 700 pages Starter Toner Cartridge) Declared cartridge yield in accordance with ISO/IEC 19752	Standard : Average Cartridge Yield 1,500 standard pages (Ships with 700 pages Starter Toner Cartridge) Declared cartridge yield in accordance with ISO/IEC 19752
	Level Sensor	No	No
Toner Count		Yes (CRUM)	Yes (CRUM)

### 2.1.2.9 Options

Items	Specification
Memory	N/A
Second Cassette	N/A
Wired Network	N/A
Wireless Network	N/A
Hard Disk	N/A
Duplex Unit	N/A

## 2.1.3 Model Comparison Table

		Samsung SCX-3200/3205 SCX-3205W	Samsung SCX-4300	HP M1120
Image				
Print speed (A4/Ltr.)		16/17ppm	18/19ppm	18/19ppm
FPOT (From ready)		10 sec	40 sec	7 sec
Resolution (Print)		Up to 1,200 x 1,200 dpi	Up to 600 x 600 dpi	Up to 600 x 600 dpi
Resolution (Scan)	Optical	Up to 1,200 x 1,200 dpi	Up to 600 x 2,400 dpi	Up to 1200 dpi
	Enhanced	4,800 x 4,800 dpi	4,800 x 4,800 dpi	Up to 19,200 dpi
Emulation		PCL5e, SPL	SPL-C	GDI
Paper Handling	Input	150 sh. Bin	250 sh. Cassette 1 MP	250 sh. Bin 10 sh. MP
	Output	50 sh.	50 sh.	100 sh.
General	Memory	32 MB (SCX-3200/3205) 128 MB (SCX-3205W)	8 MB	32 MB
	Interface	Hi-Speed USB 2.0 Wireless (SCX-3205W)	Hi-Speed USB 2.0	High speed USB 2.0
	Noise level	49 dBA	48 dBA	52 dBA
	Dimension (WxDxH)	15.9" x 11.7" x 9.2"	16.1" x 16.8" x 9.1"	18.00" x 14.5" x 12.7"
	Consumables	1.5K	2K(1K)	2.0K

## 2.2 System Overview

This chapter describes the functions and operating principal of the main component.

### 2.2.1 Front View

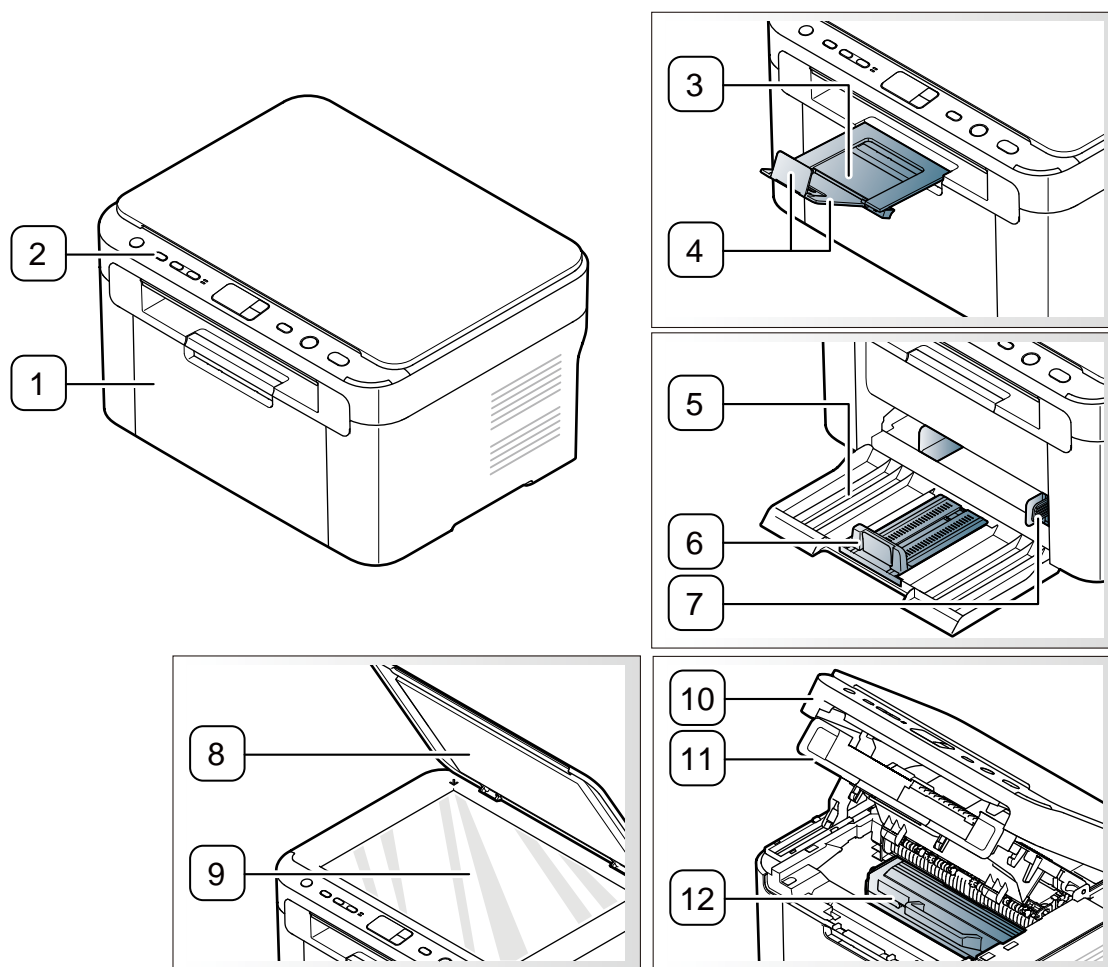

This illustration may differ from your machine depending on its model.

1	Front door	7	Paper width guides
2	Control panel	8	Scanner lid
3	Output tray (face down)	9	Scanner glass
4	Output support	10	Scan unit
5	Tray	11	Inner cover
6	Paper length guide	12	Toner cartridge

## 2.2.2 Rear View

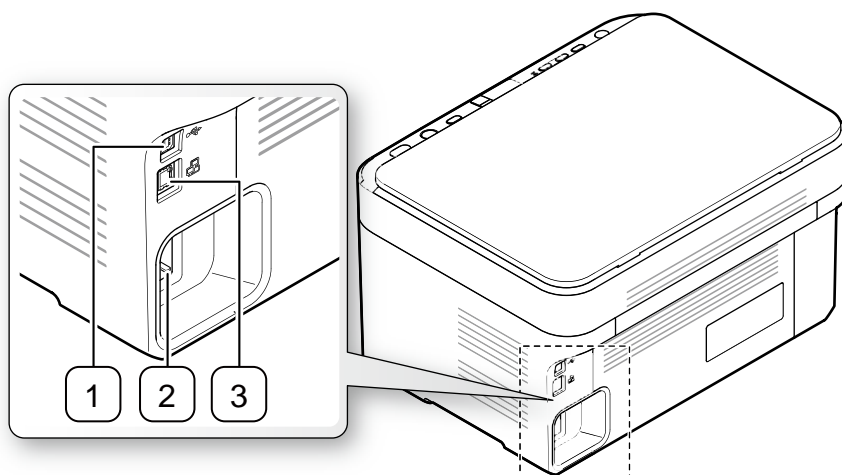

This illustration may differ from your machine depending on its model.

1	USB port	3	Network port <sup>a</sup>
2	Power cord receptacle		

a. SCX-3205W(K) only

## 2.2.3 System Layout

This model consists of the Engine parts and F/W, and said engine parts consists of the mechanical parts comprising the Frame, Feeding, Developing, Driving, Transferring, Fusing, Cabinet and H/W. The electrical systems are comprised of the main control board, power board, operation panel, PC Interface.

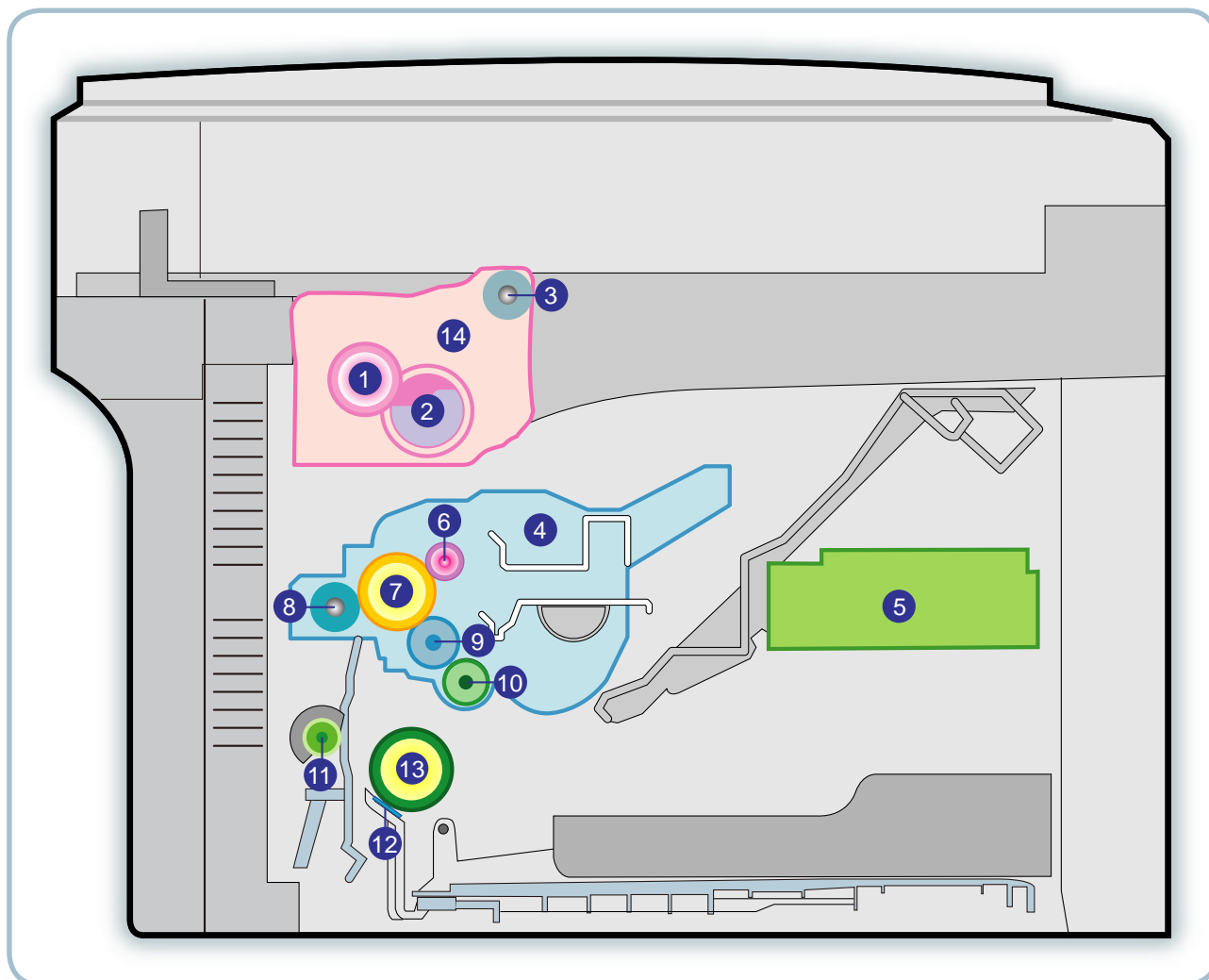

NO.	NAME
1	Pressure roller
2	Heat roller
3	Exit roller
4	Toner Cartridge
5	LSU
6	Charge roller
7	OPC

NO.	NAME
8	Transfer roller
9	Deve roller
10	Supply roller
11	Feed roller
12	Friction pad
13	Pickup roller



### 2.2.3.1 Feeding Part

It consists of a basic cassette, an MP tray for printing on special media (envelope, label, special paper).

#### 1) Separation method

Paper is separated by the friction pad mounted to the center of the cassette.

#### 2) Input tray

This model uses a bin-type tray to hold the paper. It takes a center loading method and applies 'friction pad separating method'. Both the side guide and the rear guide can be adjusted for various types of papers from A6 to legal size paper. The input tray uses a Paper Empty Sensor for paper detection. (Capacity: 150 sheets (80g/m<sup>2</sup> paper standard), paper arranging function, various size papers accepting function. In the front side, there is a paper level indicator.



#### 3) Pick-up roller

The paper feed system is comprised of a paper pickup, driving, control function, paper feeding, and static removal function. The Pick up roller is driven by a solenoid.

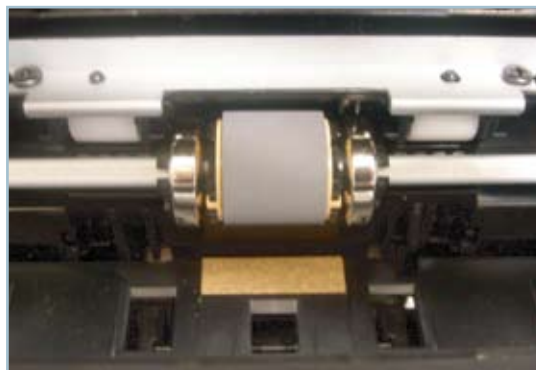

### 2.2.3.2 Transfer Roller

- The transfer roller delivers the toner from the OPC drum to the paper.
- There is no PTL Ass'y.
- Life Span : Print over 30,000 sheets (in15~30℃)



### 2.2.3.3 Driver Assy

- The SCX-3200/3205 Series drive system is comprised of an OPC, Pick- up, Feed, Fuser, Gear- Train all fixed to as mounting bracket. A step motor is used for driving the assembly; it mounted to the left frame.
  - Driving Frequency: Step Motor 840 PPS (1050rpm)
  - Drive system is comprised of: Stepping Motor → Pick-up/Feeder/Transfer/Fuser/Exit



### 2.2.3.4 Fuser

The Fuser Unit consisted of a halogen lamp, heat roller, pressure roller, thermistor and thermostat. It fuses the toner on a paper by a combination of heat and pressure to complete the printing job.



#### 1) Thermostat

When a heat lamp is overheated, a Thermostat cuts off the main power to prevent over- heating.

- Thermostat Type : Non- Contact type dual THERMOSTAT
- Control Temperature :  $195^{\circ}\text{C} \pm 5^{\circ}\text{C}$

#### 2) Thermistor

It is a temperature detecting sensor.

- Temperature Resistance :  $7\text{ k}\Omega$  ( $180^{\circ}\text{C}$ )

Provide spec cold at room temp

Example: 375K ohms

#### 3) Heat roller

The heat roller transfers the heat from the lamp to apply a heat on the paper.

The surface of a heat roller is coated with Teflon, so toner does not stick to the surface.

#### 4) Pressure roller

A pressure roller mounted under a heat roller is made of a silicon resin, and the surface also is coated with Teflon. When a paper passes between a heat roller and a pressure roller, toner adheres to the surface of a paper permanently.

#### 5) Halogen Lamp

- Voltage 120 V :  $115 \pm 5\%$
- 220 V :  $230 \pm 5\%$
- Capacity : 600 Watt  $\pm 25\text{ W}$

## 6) Items for safety

### Protecting device for overheating

- 1st protection device: Hardware cuts off when overheated
- 2nd protection device: Software cuts off when overheated
- 3rd protection device: Thermostat cuts off main power.

### Safety device

- The fuser power is cut off when a front cover is opened
- A caution label has been added to the Fuser Unit to warn the customer of the "Hot Area", so they can use care when in that area. It can be easily seen when customer opens the rear cover.

### 2.2.3.5 LSU (Laser Scanner Unit)

It is the core part of the LBP which switches from the video data received to the controller to the electrostatic latent image on the OPC drum by controlling laser beam, exposing OPC drum, by use of a polygon mirror. The OPC drum is synchronized with the paper feeding speed. The /HSYNC signal is created when the laser beam from LSU reaches the end of the polygon mirror, and the signal is sent to the controller. The controller detects the /HSYNC signal to adjust the vertical line of the image on paper. The /HSYNC signal is used to synchronize the image data with the left margin of the paper.

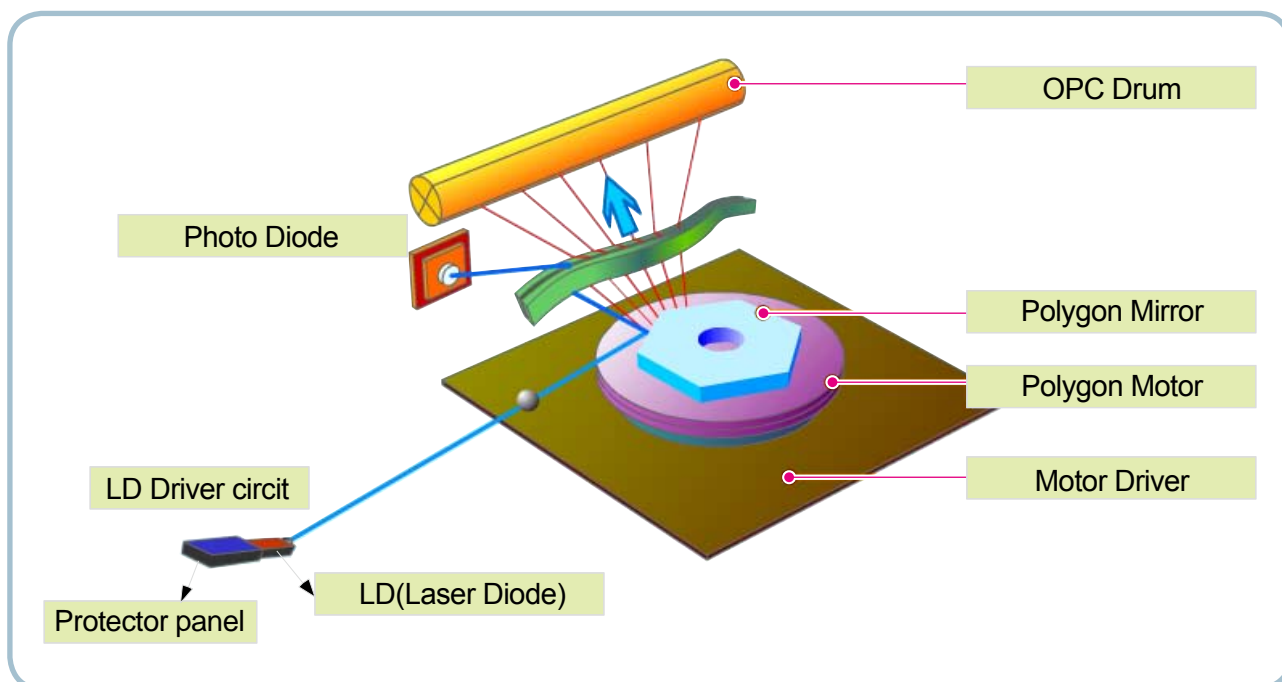

### 2.2.3.6 Toner Cartridge

By using the electronic photo process, it creates a visual image. In the toner cartridge, the OPC unit and the developing unit are contained in one assembly. The OPC unit houses the OPC drum and charging roller, the toner cartridge unit houses the toner, supply roller, developing roller, and blade (Doctor blade)

- Developing Method : Non magnetic 1 element contacting method
- Toner : Non magnetic 1 element shatter type toner
- Charging capacity :  $- 39.1 \pm 3 \mu\text{C/g}$
- Average OD :  $8.0 \pm 0.5 \mu\text{m}$  (Toner)
- The life span of toner (ISO 19752 pattern / Letter standard)
  - Initial toner : 0.7K
  - Sales toner : 1.5K
- Toner Residual Sensor : Dot count with CRUM(CRU Monitor)
- OPC Cleaning : Collect the toner by using cleaning blade
- Handling of wasted toner : Waste [residual] toner is cleaned off the drum by means of a cleaning blade.
- OPC Drum Protecting Shutter : None
- Classifying device for toner cartridge : ID is classified by CRUM.

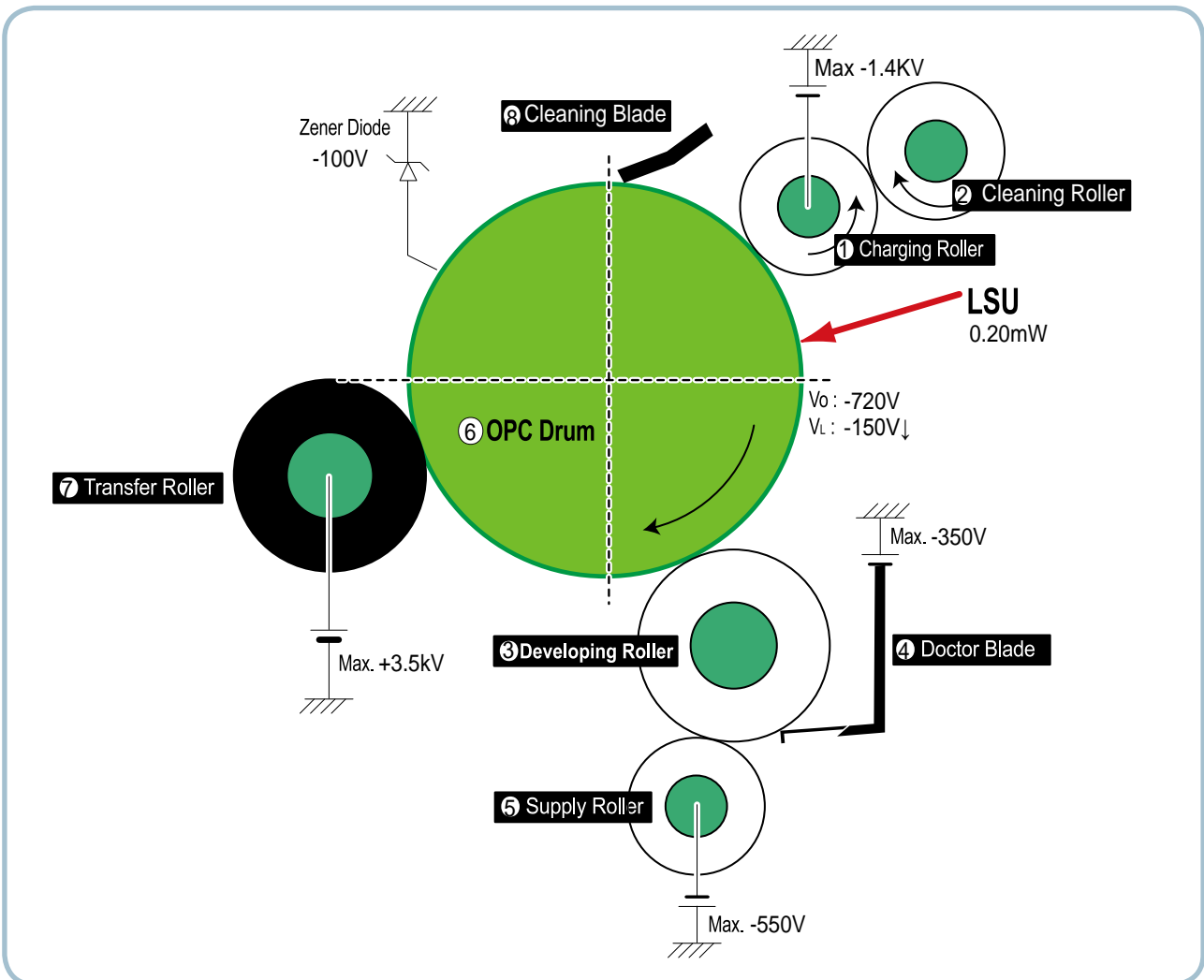

## 2.2.4 Engine H/W Specifications

### 2.2.4.1 Main PBA

The Engine and the Printer Controller function are housed into one Main Board called Main PBA. The CPU is functioned as the bus control, I/O handling, drivers, and PC interface. The main board sends the Current Image of Video data to the LSU and manages the conduct of manages the electrophotography for printing. The CPU on Main PBA manages the circuits for the motors: paper feed, paper path, clutches, pre-transfer lamp, current control to driver components, and fan driving.

The signals from the paper feed jam sensor and paper empty sensor are directly inputted to the main board.

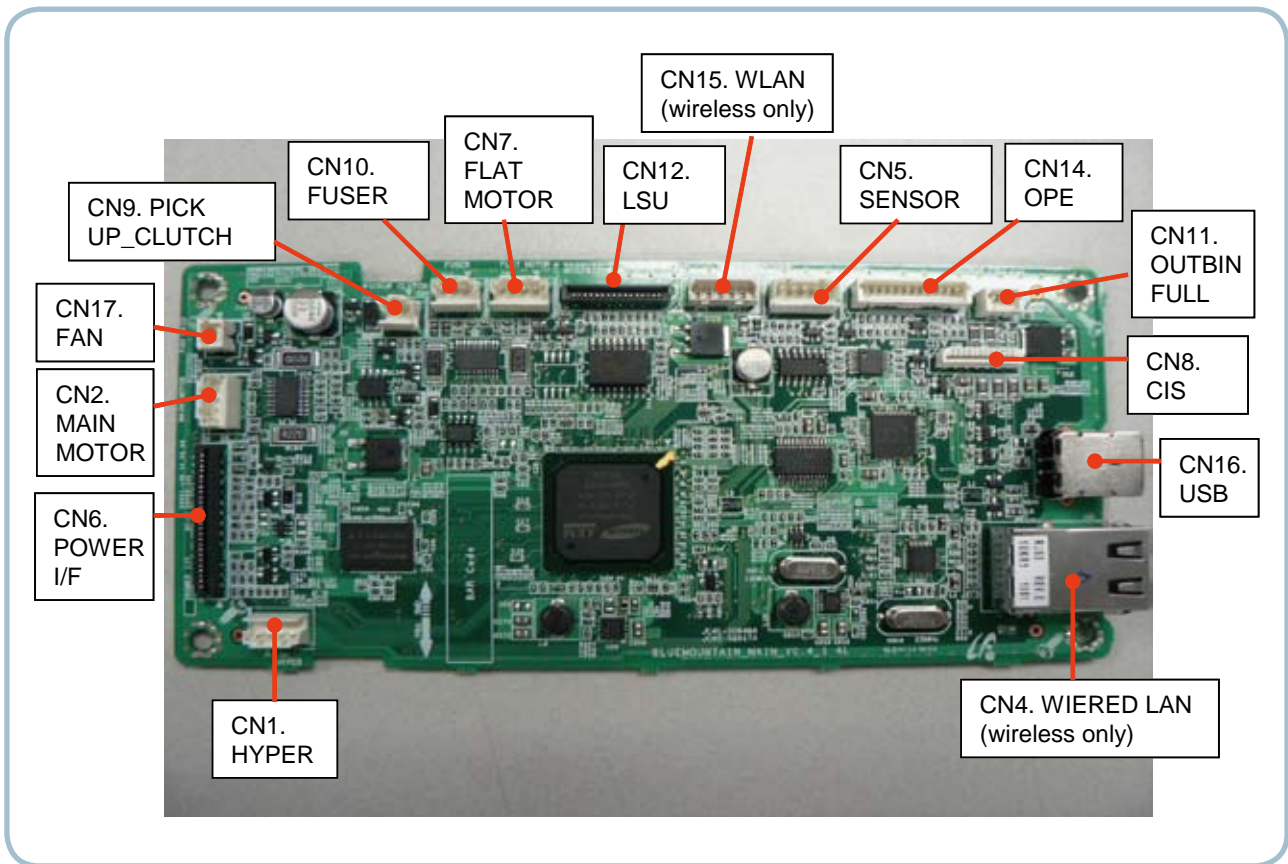

### (a) ASIC (Jupiter5)

- CPU Core : Use 32 Bit RISC Processor of Jupiter5 which uses ARM 926EJS core.
- the main function of ASIC has the following features;
  - > Multi-layered bus architecture for bus traffic distribution
  - > Multi-Port DDR SDRAM Controller
  - > external NOR flash controller and SPI interface, which Supports Auto Boot operation using external Serial Flash.
  - > Speed
- Up to 133MHz Bus Interface and DRAM interface
- GDI Mono MFP: up to 30 ppm at 2400 dpi mode
- Supports A4 paper size

### (b) Memory

- 1) Serial-type nor flash memory
  - Store System Program and can be download System Program through PC Interface
- Capacity : 4MByte(SCX-3200/3205), 8MByte(SCX-3205W)
- 2) DDR2 SDRAM
  - When Printing, use Band Buffer, System Working Memory Area.
- Capacity : 32M Byte (SCX-3200/3205)  
128M Byte (SCX-3205W)  
for printing System Working Memory Area



### (c) Sensor Input Circuit

#### ■ Paper Empty Sensing

The Paper empty sensor on the tray detects the state of paper empty and the state of paper width i.e. narrow paper width or not.

#### ■ Regi Sensing

N/A

#### ■ Paper Feeding

When paper passes the actuator (feed sensor part), it detects the signal by use of a Photo interrupter, informs the CPU, and synchronizes the image data after a predetermined time.

If it doesn't detect the feed sensor within 1sec. after paper is fed, paper Jam0 is occurred (LED will be display Orange color).

#### ■ Paper Exit Sensing

N/A

#### ■ Cover Open Sensing

The Cover open sensor is located on the HVPS. After the top cover is opened, +24VS (Solenoid, Main Motor, Polygon motor part of LSU and HVPS), which is supplied to the each unit, is cut off.

In case, the red light will be ON to inform the end-user.

#### ■ SOLENOID Driving

The clutches are driven by turning on the TRs, which is controlled by the CPU. The diode in the Clutch driving circuits protects TR driven from the noise, which may occur when the solenoid is de-energized.

#### ■ Motor Driving

The main motor driving circuits is on the main board

There is motor driver IC on the main board, to control the step motor.

## 2.2.4.2 HVPS and SMPS Board

The HVPS Board and SMPS Board housed in one board.

The HVPS board creates the high voltage of THV/MHV/Supply/Dev and supplies it to the developer portion, so as to develop the optimum image quality. The HVPS portion takes the 24V and outputs the high voltage for THV/MHV/BIAS, and supplied to the high voltage, OPC cartridge, and transfer roller for optimum latent image and toner transfer quality.

It is the power source of entire system. It is assembled by an independent module, so it is possible to use for common use. It is mounted on the side of the machine.

It is consisted of the SMPS portion, which supplies the DC power for driving the system, and AC to power the Fuser Unit. SMPS has two output channels, which are +3.3V and +24V.

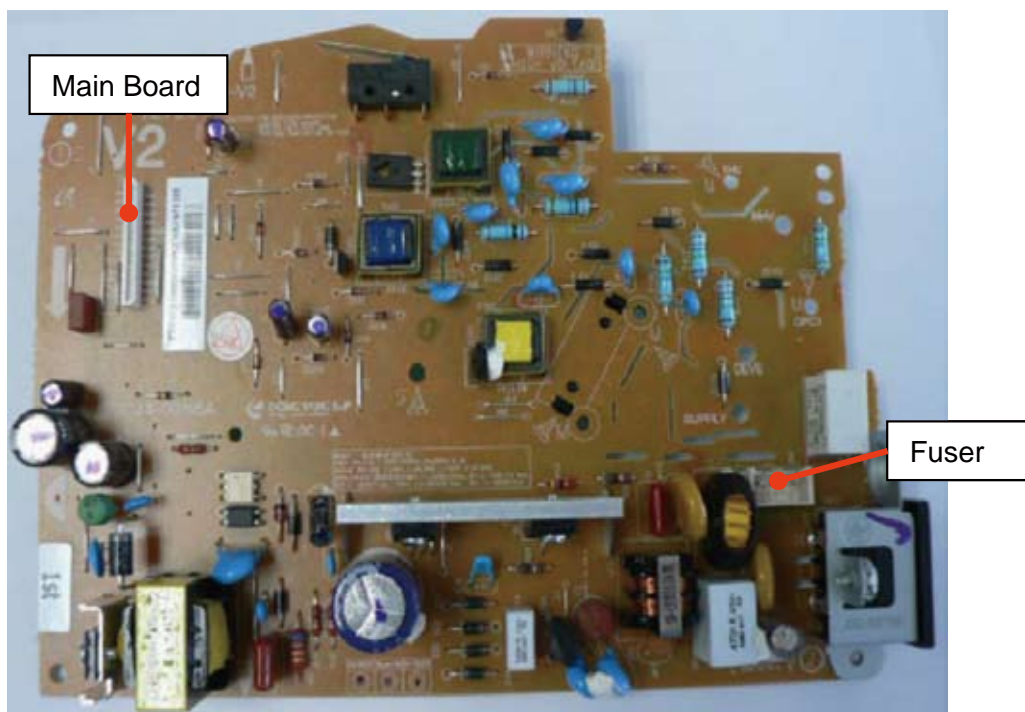

## ■ HVPS Board

### • Transfer High Voltage (THV+)

- Input Voltage : 24 V DC  $\pm$  15%
- Output Voltage : THV+: max +3.5kV  $\pm$  10 %,(Duty Variable, no loading )  
THV-: -1kV $\pm$ 20% (when cleaning,200 M $\Omega$ )
- Input contrast of the Voltage stability degree : under  $\pm$  3 % (fluctuating input 21.6V~26.4V)  
Loading contrast :  $\pm$  3 % or less
- Output Voltage Rising Time : 50 ms Max
- Output Voltage Falling Time : 100 ms Max
- Fluctuating transfer voltage with environmental various : 0~3.5kV
- Environment Recognition Control Method : The THV-PWM ACTIVE is transfer active signal. It detects the resistance by recognizing the voltage value, F/B, while permits the environmental recognition voltage.
- Output Voltage Control Method : Transfer Output Voltage is outputted and controlled by changing Duty of THVPWM Signal.

### • Charge Voltage (MHV)

- Input Voltage : 24 V DC  $\pm$  15%
- Output Voltage : -1.0KV ~ -1.8KV DC  $\pm$  3%
- Output Voltage Rising Time : 50 ms Max
- Output Voltage Falling Time : 50 ms Max
- Output Loading range : 30 M $\Omega$  ~ 1000 M $\Omega$
- Output Control Signal(MHV-PWM) : CPU is HV output when PWM is Low

### • Cleaning Voltage (THV- )

- The (+) Transfer Voltage is not outputted because the THV PWM is controlled with low.
- The (-) Transfer Voltage is outputted because the THV-Enable Signal is controlled with low
- The output fluctuation range is big because there is no Feedback control.

### • Developing Voltage (DEV)

- Input Voltage : 24 V DC  $\pm$  15%
- Output Voltage: -200V ~ -500V DC  $\pm$ 3%
- Output Voltage Fluctuation range: PWM Control
- Input contrast of the output stability degree :  $\pm$  3 % or less  
Loading contrast :  $\pm$  3 % or less
- Output Voltage Rising Time : 50 ms Max
- Output Voltage Falling Time : 50 ms Max
- Output Loading range : 10M $\Omega$  ~ 1000 M $\Omega$
- Output Control Signal (BIAS-PWM) : the CPU output is HV output when PWM is low.

### • Supply

- Output Voltage : -350 V ~ -650V DC  $\pm$ 50 V(ZENER using, DEV )
- Input contrast of the output stability degree : under  $\pm$  5 %  
Loading contrast :  $\pm$  5 % or less
- Output Voltage Rising Time : 50 ms Max
- Output Voltage Falling Time : 50 ms Max
- Output Loading range : 10 M $\Omega$  ~ 1000 M $\Omega$
- Output Control Signal (BIAS-PWM) : the CPU is HV output when PWM is low.

## ■ SMPS Board

### • AC Input

- Input Rated Voltage : AC 220V ~ 240V AC 110V ~ 127V
- Input Voltage fluctuating range : AC 180V ~ 270V AC 90V ~ 135V
- Rated Frequency : 50/60 Hz
- Frequency Fluctuating range : 47 ~ 63 Hz
- Input Current : Under 4.0Amps / 2.0Amps (But, the status when Fuser is off or rated voltage is inputted/ outputted)

### • Rated Output Power

NO	ITEM	CH1	CH2	Remark
1	CHANNEL NAME	+3.3V	+24.0V	
2	CONNECTOR PIN	CON 3 3.3V PIN: 5,7 GND PIN: 8,9	CON 3 24V PIN:1,2,3 GND PIN:8,9,25,26	
3	Rated Output	+3.3V±5% (3.135~3.465V)	+24V±10% -> -10%, +15%, (21.6~26.4V) -> 27.6V	
4	Max. Output Current	0.8A	1.35A	
5	Peak Loading Current	1.0A	1.8A	100ms
6	RIPPLE NOISE Voltage	100mVp-p	Under 500mVp-p	
7	Maximum output	2.64W	32.4W	
8	Peak output	3.3W	43.2W	100ms
9	Protection for loading shortage and overflowing current	Shut down or Fuse Protection	Shut down or Output Voltage Drop	

## 2.2.5 Engine F/W Contol Algorithm

### 2.2.5.1 Feeding

If feeding from a cassette, drive of the pickup roller is controlled by a solenoid. The on/off of the solenoid is controlled by controlling the general output port or the external output port. Provided below are the units jam conditions:

Item	Description
JAM 0	<ul style="list-style-type: none"> <li>- After picking up, paper is not fed.</li> <li>- After picking up, paper entered but it cannot reach to the feed sensor in a predetermined time due to slippage, etc.</li> <li>- After picking up, if the feed sensor is not on, re-pick up. After re-picking up, if the feed sensor is still not on after a predetermined time, JAM 0 is displayed.</li> <li>* <i>It is a status that the leading edge of the paper doesn't pass the feed sensor.</i></li> <li>- Even though the paper reaches to the feed sensor, the feed sensor doesn't be ON.</li> <li>* <i>It is a status that the leading edge of the paper already passes the feed sensor.</i></li> </ul>
JAM 1	<ul style="list-style-type: none"> <li>- After the leading edge of the paper passes the feed sensor, the trailing edge of the paper must clear the sensor within a predetermined time. (The feed sensor cannot be OFF)</li> </ul>

### 2.2.5.2 Transfer

The charging, developing and the transfer voltages. are controlled by PWM (Pulse Width Modulation). Each output voltage is changeable due to the PWM duty. The transfer voltage admitted when the paper passes the transfer roller is decided by environment conditions. The resistance value of the transfer roller is changed due to the surrounding environment ; the voltage values change to compensate for the environmental conditions. It is managed through an AD converter. The voltage value for the transfer roller is decided by the changed value.

### 2.2.5.3 Fusing

---

The temperature change of the heat roller's surface is changed to the resistance value through the thermistor. The Heat Roller temperature (warmup) is measured by converting the resistance of the thermistor to a measurable DC voltage value. The AD converter changes it to a digital value so it knows when it has reached its proper fusing temperature. The AC power to the fuser lamp is controlled by comparing the target temperature to the value from the thermistor. If the value from the thermistor is out of the controlling range, an error will occur and power is disabled. Each heading below lists the types of Fuser Errors that can occur:

- **Open Heat Error**

During warmup, if the Fuser Unit does not reach its proper operating temperature within a predetermined time, an "Open Heat Error" will occur. An error message will be displayed on the Control Panel alerting the customer. The engine stops all functions and keeps it at the error state until the issue is resolved by a qualified technician.

- **Low Heat Error**

After initial warmup has been achieved, if the Fuser Unit at any time does not reach its proper operating temperature within a predetermined time, a "Low Heat Error" will occur. An error message will be displayed on the Control Panel alerting the customer. The engine stops all functions and keeps it at the error state until the issue is resolved by a qualified technician.

- **Over Heat Error**

If the Fuser Unit at any time exceeds the specified range [too hot] for proper operating temperature, an "Over Heat Error" will occur. An error message will be displayed on the Control Panel alerting the customer. The engine stops all functions and keeps it at the error state until the issue is resolved by a qualified technician.

### 2.2.5.4 LSU

---

LSU receives the image data from PVC or HPVC and makes the latent image on the OPC surface. It uses the single beam, LD.

The errors related to LSU are as follows:

- **By LReady** : When the printing is started, the engine drives the polygon motor of LSU. After the specified time is elapsed, if the motor is not in a ready status, the engine detects the error that the polygon motor is not in a ready status. If this error happens, the engine stops all functions and keeps it at the error state. Also, the engine informs the error status of the main system and the error message is displayed at the LCD window to inform the error status to the customer.
- **By Hsync** : When the polygon motor is ready, the LSU sends out the signal called Hsync and it is used to synchronize with each image line. So, if the engine does not detect consecutively the signal for a fixed time, it defines the Hsync Error. If this error happens, the engine stops all functions and keeps it at the error state. Also, the engine informs the error status of the main system and then the error message is displayed at the LCD window to inform the error status to the customer.  
LSU Error Recovery: If the LReady or Hsync error happens, the paper is ejected with no image on it. The engine mode is changed to recovery mode and the engine informs the main system of the engine mode. And the engine checks the LSU error. If the error doesn't happen, the printing job will be proceeding.

## 2.2.6 S/W Descriptions

### 2.2.6.1 Overview

The software of SCX-3200/3205 Series system is constructed as follows:

- 1) The Host Software is an application software that can operate in a Windows and/or Web Environment.
- 2) The Firmware portion is an Embedded software controlling the print job.

### 2.2.6.2 Architecture

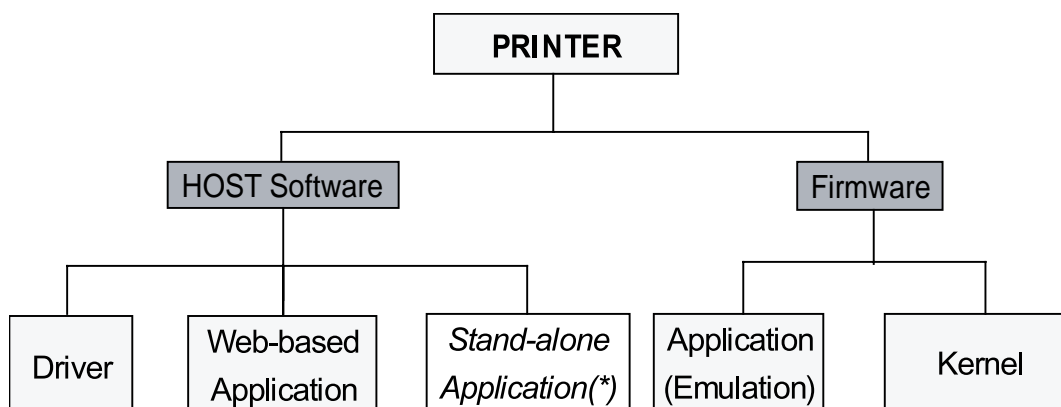

☞ (\*) is job for common S/W team

#### Host Software is made up of:

1. Graphic User Interface that offers the various editing functions to user.
2. Driver that translates the received document to a Printing Command Language which printer can understand and transfers data to spooler.
3. Stand-alone Application that offers the various printing application, PSU(Printer Settings Utility), Printer Status Monitor, Network Management in Window system.
4. Web-based-Application that offers the same functions as Stand-alone Application and RDC(Remote Diagnosis Control) in Web environment.

#### Firmware is made up of:

1. Application (Emulation) that is a interpreter translate data received from Host to a printing language (PCL, PS, GDI, etc.) to be able to allow the user to take same output as original composed in Host.
2. Kernel that control and management the whole procedure include of Control flow and Printing Job before transfer to Engine system.

### 2.2.6.3 Data and Control Flow

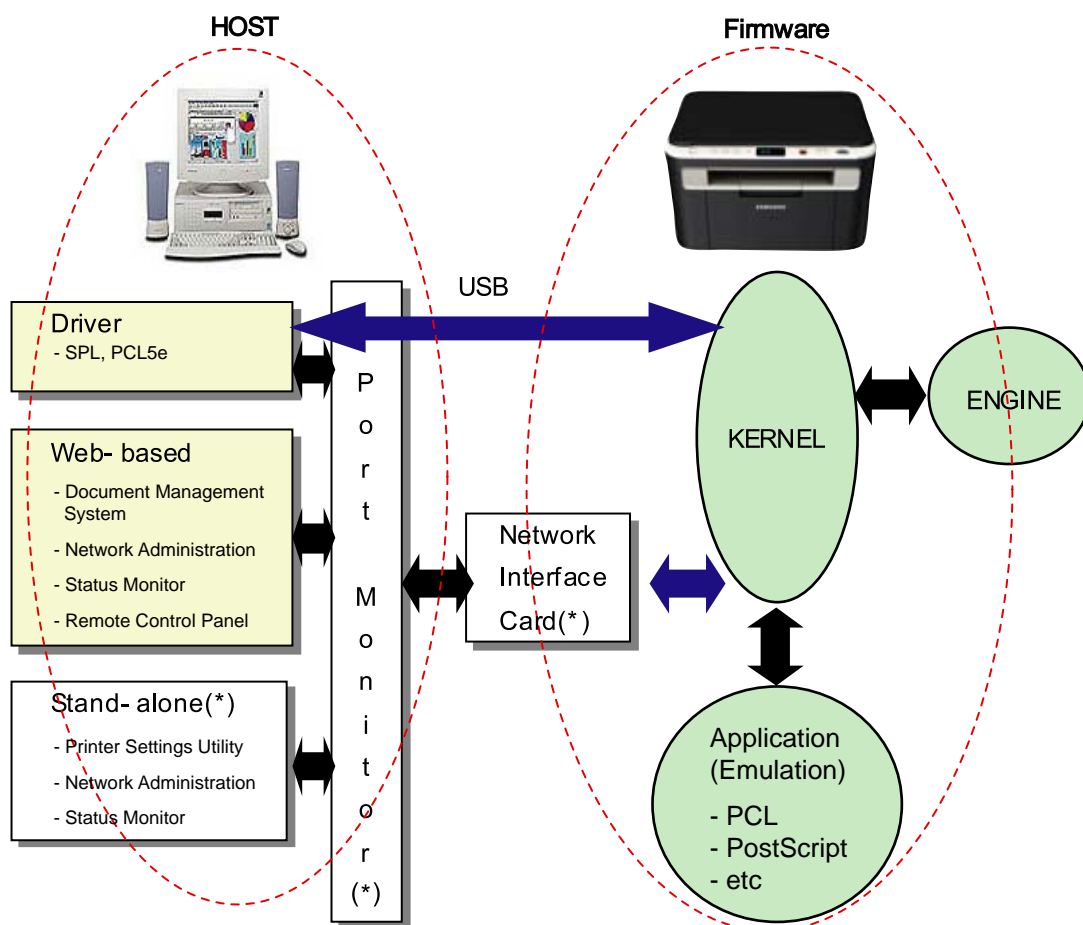

Note: (\*) is role of N/W I/F

Provided below is a detail explanation of the Block Diagram above.

Host Side is made up of:

1. The Print Driver that is Windows application software translates printed data to one of printer languages and creates spooler file.
2. Web-based Application offer a variety of additional functions for the printer; management of printing job, printer administration, Status monitor to monitoring the printer status by real time in Web, independent environment on OS.
3. Stand-alone Application that is a similar Window software as same as above 2,
4. Port Monitor that manages the network communication between spooler and Network Interface Card, or various additional application and Network Interface Card,(this is, at first, make communication logical port, manage the data, transfer them from spooler to network port, and offer the result of printing).



**Firmware Side is made up of:**

1. Network Interface Card is that relay the communication between Host and kernel using various network protocols.
2. Kernel manages the flow control of emulation procedure, receiving data from the Host or Network card and printing with engine & rendering job.
3. Emulation interprets the various output data from selected emulation.
4. Engine prints rendered bit-map data to paper with required size and type by Kernel.

The Job Spooling function for Multi-User, Multi-Printing that is occurred in Network printing and various additional printing functions, this Kernel use max. 10 Queuing systems in a memory.

**In Printing, the two procedures are:****(1) Case of using USB Port**

- After user start to print their document to PCL string or compressed GDI bit-map data; the driver translates the all graphic data and send the data to host spooler. And then the spooler sends the data stream to the printer via USB port.
- Kernel receives this data from the Host, and then selects the emulation fit to data and start selected one. After emulation job ends Kernel sends the output bit-map data to Engine using Printer Video Controller (by clock type for LSU).
- Engine print the received data to required paper with the sequential developing process.

**(2) Network Interface Card**

- After the user starts to print their document to PCL string or compressed GDI bit-map data, Driver translate the all graphic data of it and send data to host spooler.
- If so, Port monitor managing network port receives data from spooler and sends a data stream to the Network Interface Card.
- Network interface card receives it and send to Kernel part.
- Kernel receives this data from Host, and selects emulation fit to data and start selected one. After emulation job ends Kernel sends the output bit-map data to the Engine using Printer Video Controller (by clock type for LSU).
- Engine print the received data to required paper with the sequential developing process.

**The additional printing function are realized in:**

- (1) Web environment.
- (2) Window environment.

On addition, Kernel informs the printing and printer status to end-user made printing job with the Status Monitor.

## 3. Disassembly and Reassembly

### 3.1 Precautions when replacing parts

#### 3.1.1 Precautions when assembling and disassembling

- \* Use only approved Samsung spare parts. Ensure that part number, product name, any voltage, current or temperature rating are correct. Failure to do so could result in damage to the machine, circuit overload, fire or electric shock.
- \* Do not make any unauthorized changes or additions to the printer, these could cause the printer to malfunction and create electric shock or fire hazards.
- \* Take care when dismantling the unit to note where each screw goes. There are 19 different screws. Use of the wrong screw could lead to system failure, short circuit or electric shock.
- \* Do not disassemble the LSU unit. Once it is disassembled dust is admitted to the mirror chamber and will seriously degrade print quality. There are no serviceable parts inside.
- \* Regularly check the condition of the power cord, plug and socket. Bad contacts could lead to overheating and fire. Damaged cables could lead to electric shock or unit malfunction.

#### 3.1.2 Precautions when handling PBA

Static electricity can damage a PBA, always use approved anti-static precautions when handling or storing a PBA.

##### >> Precautions when moving and storing PBA

1. Please keep PBA in a conductive case, anti-static bag, or wrapped in aluminum foil.
2. Do not store a PBA where it is exposed to direct sunlight.

##### >> Precautions when replacing PBA

1. Disconnect power connectors first, before disconnecting other cables
2. Do not touch any soldered connections, connector terminals or other electronic parts when handling insulated parts.

##### >> Precautions when checking PBA

1. Before touching a PBA, please touch other grounded areas of the chassis to discharge any static electrical charge on the body.
2. Take care not to touch the PBA with your bare hands or metal objects as you could create a short circuit or get an electric shock. Take extra care when handling PBAs with moving parts fitted such as sensors, motors or lamps as they may get hot.
3. Take care when fitting, or removing, screws. Look out for hidden screws. Always ensure that the correct screw is used and always ensure that when toothed washers are removed they are refitted in their original positions.

#### 3.1.3 Releasing Plastic Latches

Many of the parts are held in place with plastic latches. The latches break easily; release them carefully.

To remove such parts, press the hook end of the latch away from the part to which it is latched.

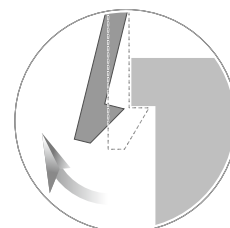

## 3.2 Screws used in the printer

The screws listed in the table below are used in this printer. Please ensure that, when you disassemble the printer, you keep a note of which screw is used for which part and that, when reassembling the printer, the correct screws are used in the appropriate places.

Part Code	Location	Description	Qty
6003-000196	FRAME	SCREW-TAPTYPE;PWH,+ ,B,M3,L10,NI PLT,SWRCH18A	8
6003-000269		SCREW-TAPTYPE;BH,+ ,-,S,M3,L6,ZPC(WHT),SWRCH18A,-	20
6003-000282		SCREW-TAPTYPE;BH,+ ,-,B,M3,L8,ZPC(BLK),SWRCH18A,-	5
6003-000282	FUSER	SCREW-TAPTYPE;BH,+ ,-,B,M3,L8,ZPC(BLK),SWRCH18A,-	3
6006-001078		SCREW-TAPTYPE;PH,+ ,WSP,B,M3,L10,ZPC(WHT),SWRCH18A	1
6003-000196	FUSER-UPPER	SCREW-TAPTYPE;PWH,+ ,B,M3,L10,NI PLT,SWRCH18A	1
6003-000282		SCREW-TAPTYPE;BH,+ ,-,B,M3,L8,ZPC(BLK),SWRCH18A,-	4
6003-000269	FUSER -LOWER	SCREW-TAPTYPE;BH,+ ,-,S,M3,L6,ZPC(WHT),SWRCH18A,-	3
6003-000196	FRAME-PAPER PATH	SCREW-TAPTYPE;PWH,+ ,B,M3,L10,NI PLT,SWRCH18A	7
6003-000282	FRAME-FEED IDLE	SCREW-TAPTYPE;BH,+ ,-,B,M3,L8,ZPC(BLK),SWRCH18A,-	2
6003-000269	FRMAE MAIN-LEFT	SCREW-TAPTYPE;BH,+ ,-,S,M3,L6,ZPC(WHT),SWRCH18A,-	6
6003-000282		SCREW-TAPTYPE;BH,+ ,-,B,M3,L8,ZPC(BLK),SWRCH18A,-	2
6003-000269	FRMAE MAIN-RIGHT	SCREW-TAPTYPE;BH,+ ,-,S,M3,L6,ZPC(WHT),SWRCH18A,-	2
6003-000269	FRAME MAIN-MIDDLE	SCREW-TAPTYPE;BH,+ ,-,S,M3,L6,ZPC(WHT),SWRCH18A,-	5
6003-000282	LSU	SCREW-TAPTYPE;BH,+ ,-,B,M3,L8,ZPC(BLK),SWRCH18A,-	5
6003-000282	COVER-TOP	SCREW-TAPTYPE;BH,+ ,-,B,M3,L8,ZPC(BLK),SWRCH18A,-	1
6003-000282	CARTRIDGE-TONER	SCREW-TAPTYPE;BH,+ ,-,B,M3,L8,ZPC(BLK),SWRCH18A,-	4
6003-000269	MAIN LINE	SCREW-TAPTYPE;BH,+ ,-,S,M3,L6,ZPC(WHT),SWRCH18A,-	8
6003-000282		SCREW-TAPTYPE;BH,+ ,-,B,M3,L8,ZPC(BLK),SWRCH18A,-	2

### 3.3 Left / Right cover

1. Remove 2 screws.



2. Open the scanner unit.



3. Take off the right cover by removing hooks from its edge.

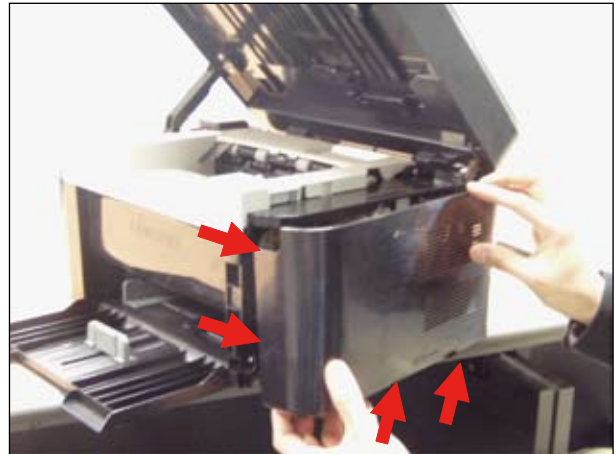

4. Take off the left cover by removing hooks from its edge.



### 3.4 Scanner unit

1. Remove the right cover.



4. Remove the holder link.



2. Unplug 4 connectors on the main PBA.

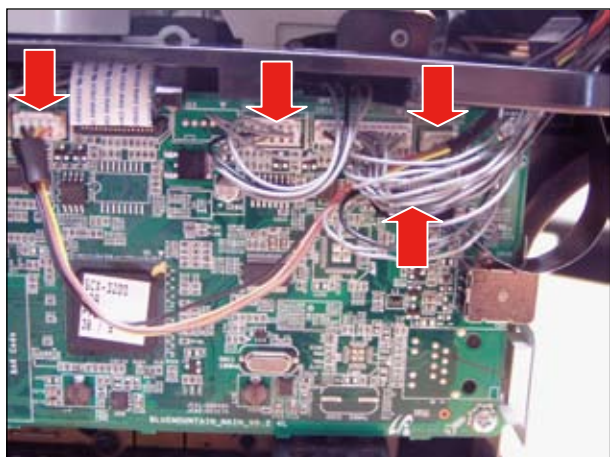

5. Release the linker from the rail while pushing it to the direction of arrow.



3. Release the connectors from the 2 holes.

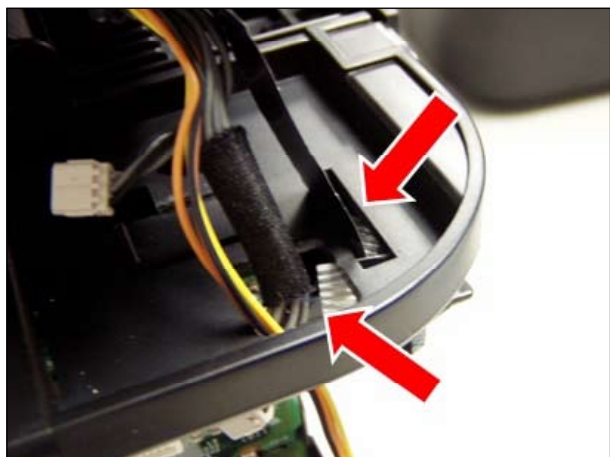

6. Push the scanner unit to the front. Lift up and release it.

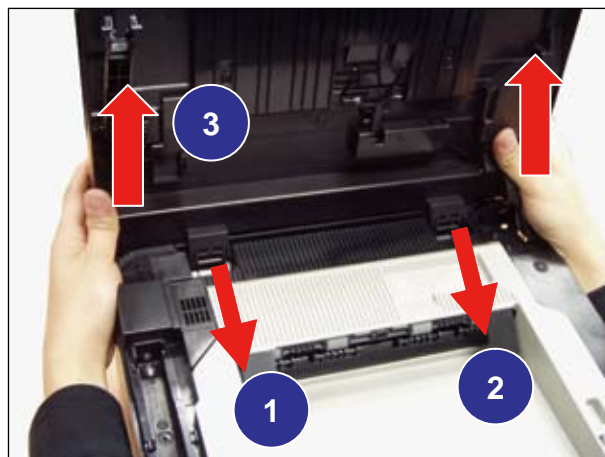

### 3.4.1 OPE unit

1. Open the scanner unit. Remove 2 screws.



3. Release the OPE unit after unplugging 2 connectors.

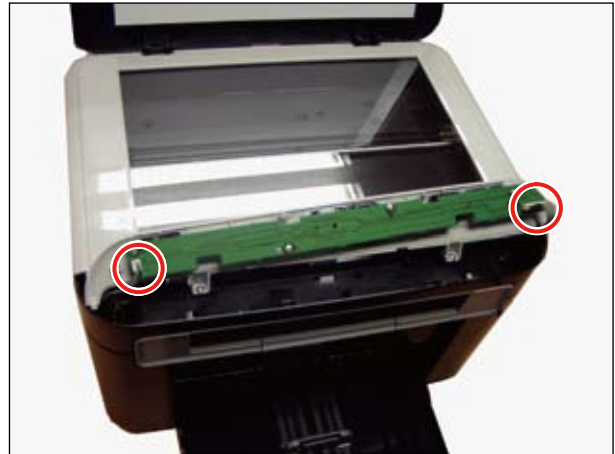

2. Pull up the OPE unit.



### 3.4.2 CIS unit

1. Remove the OPE unit. (Refer to 3.4.1)

2. Remove 2 screws.



3. Lift up and release the scan glass.



4. Unplug the flat cable from the left.

5. Release the hook from the right.

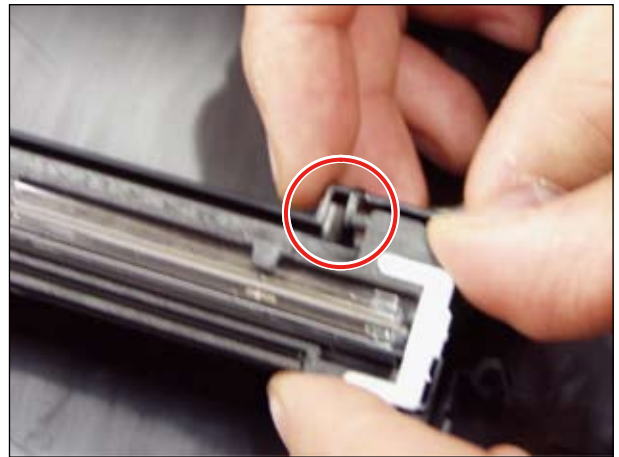

6. Release the CIS unit.

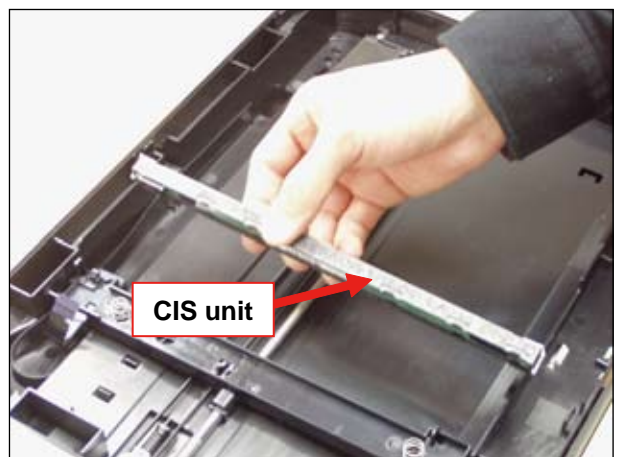

### 3.4.3 Scan motor

1. Remove the scan unit. (Refer to 3.4)
2. Turn the scan unit over. Remove the CAP-SENSOR after removing 1 screw.

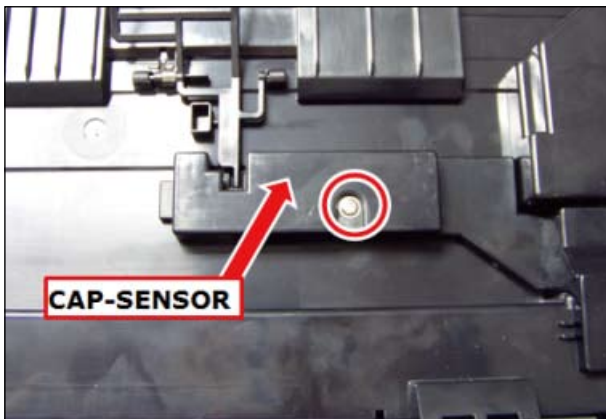

3. Remove the OPE unit and scan glass. (Refer to 3.4.1~3.4.2)
4. Release the belt.

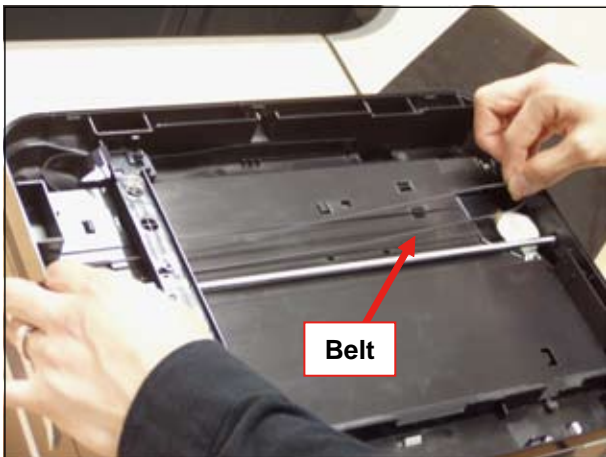

5. Release the shaft.

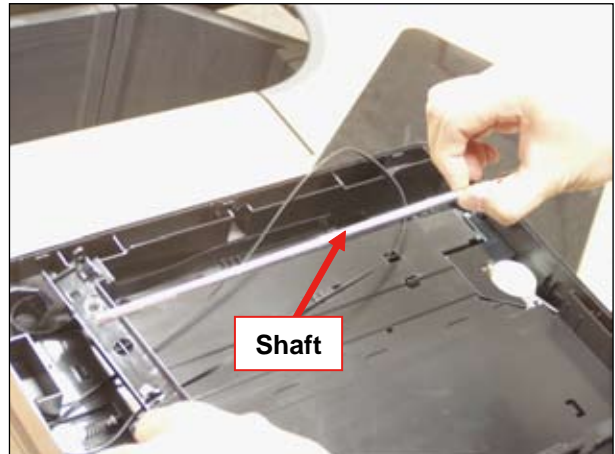

6. Release the CAP-SCAN Motor after removing 1 screw.

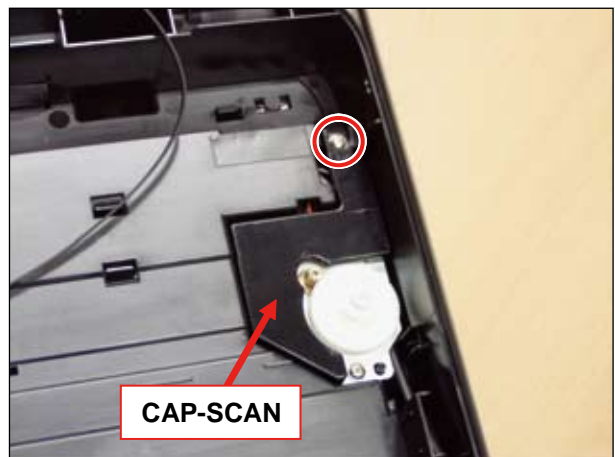



7. Remove 3 screws.

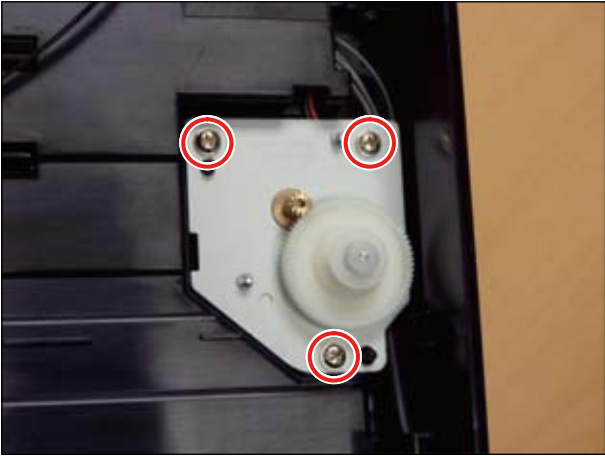

8. Release the scan motor.



### 3.5 Middle cover and COVER-OPEN

1. Remove the scanner unit. (Refer to 3.4)
2. Release the link from both sides of the COVER-OPEN.

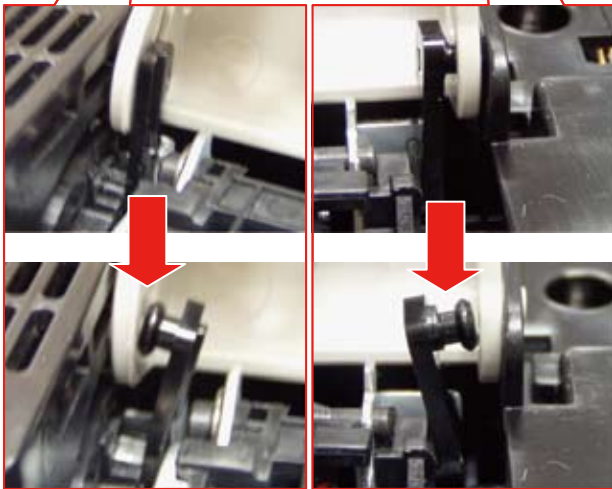
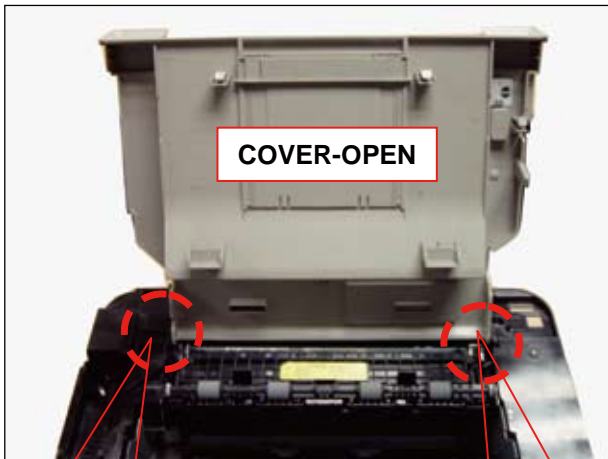

3. Unplug the connector on the main PBA.

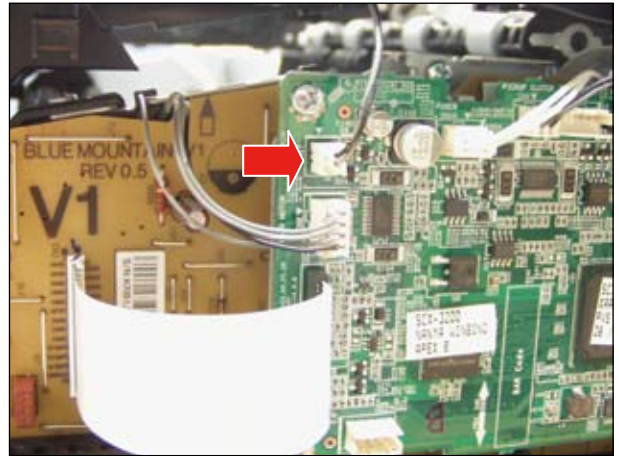

4. Lift up and release the middle cover and COVER-OPEN after removing 4 screws.

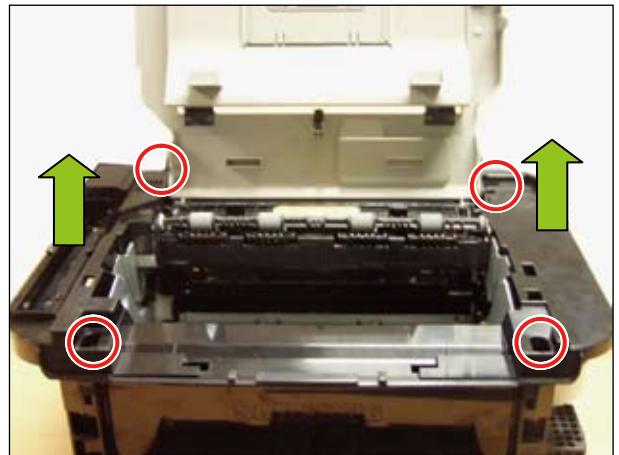

### 3.6 Front and Rear cover

1. Remove the left and right cover.  
(Refer to 3.3)
2. Remove the scanner unit. (Refer to 3.4)
3. Remove the middle cover. (Refer to 3.5)
4. Release the rear cover after removing 4 screws.

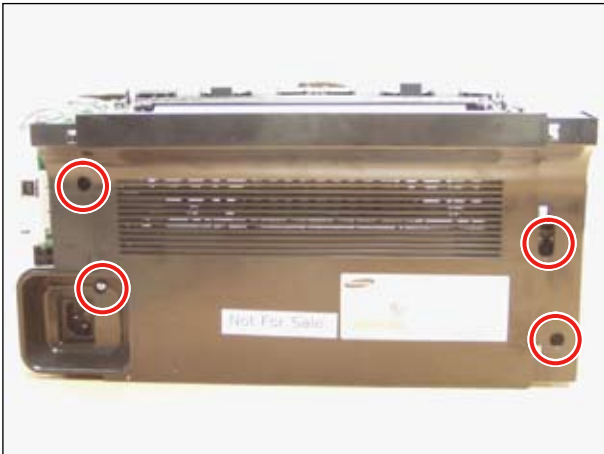

5. Release the front cover after removing 2 screws.

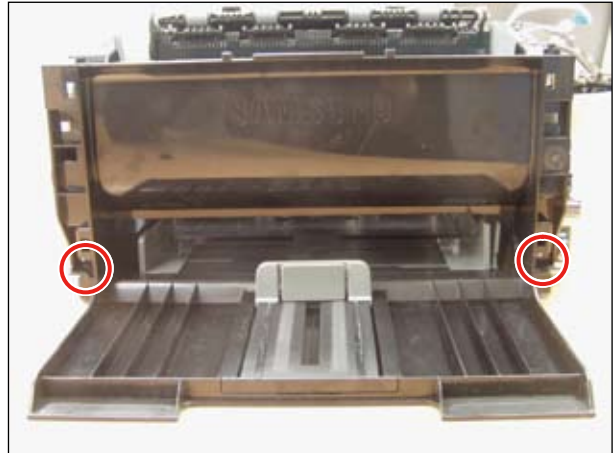

### 3.7 Main PBA

1. Remove the right cover.



2. Release the main PBA after removing 4 screws and all connectors.

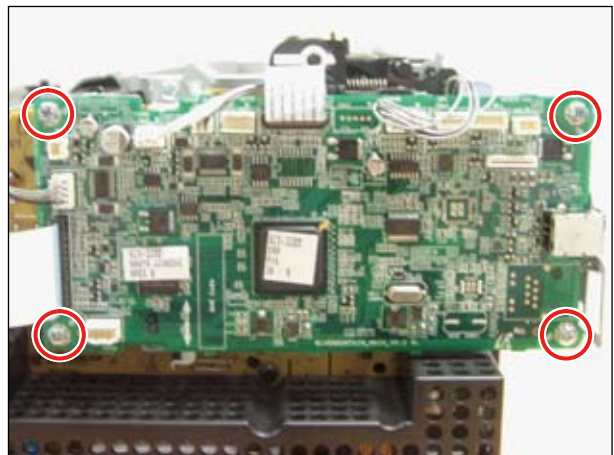

### 3.8 SMPS / HVPS board

1. To remove the SMPS/HVPS board, first remove the right/middle/rear cover. (Refer to 3.3~3.6)
2. Remove 4 screws. Unplug all connectors. And release the main-PBA bracket.

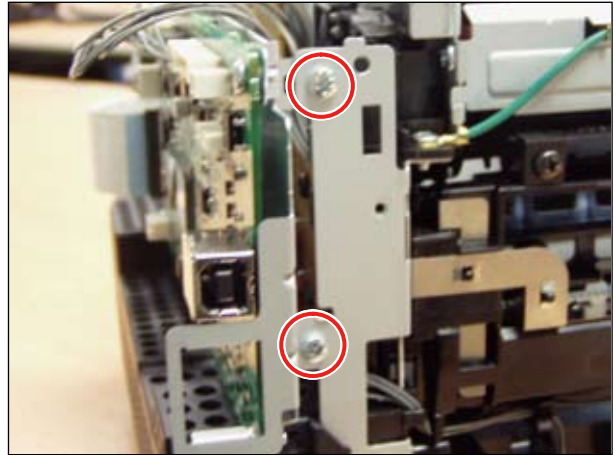
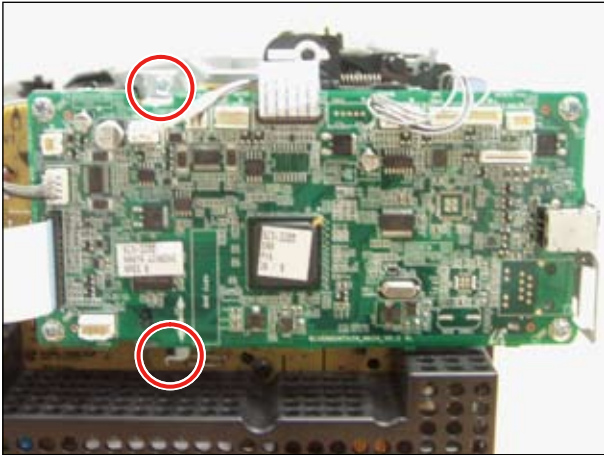

3. Remove the SMPS-cover after removing 1 screw.

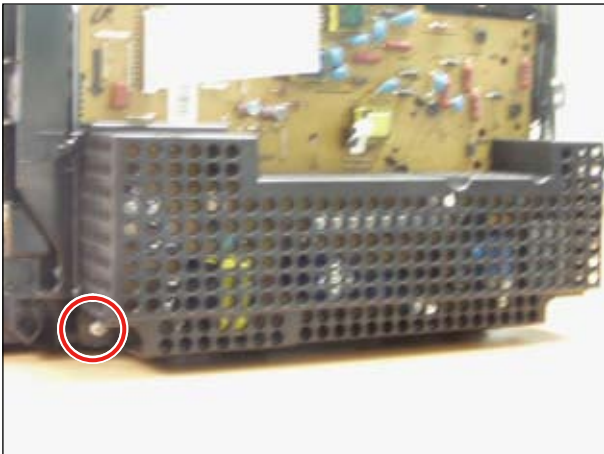

4. Unplug the fuser connector.

5. Release the SMPS/HVPS board after removing 11 screws.

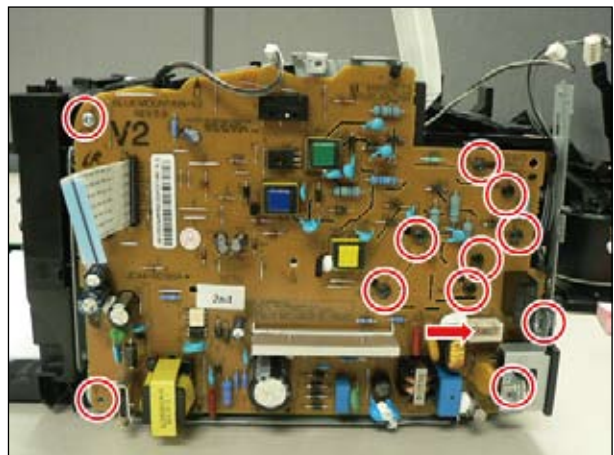

### 3.9 Fuser unit

1. Remove the right / scanner unit / middle / rear cover. (Refer to 3.3~3.6)
2. Unplug the connector on SMPS/HVPS board.

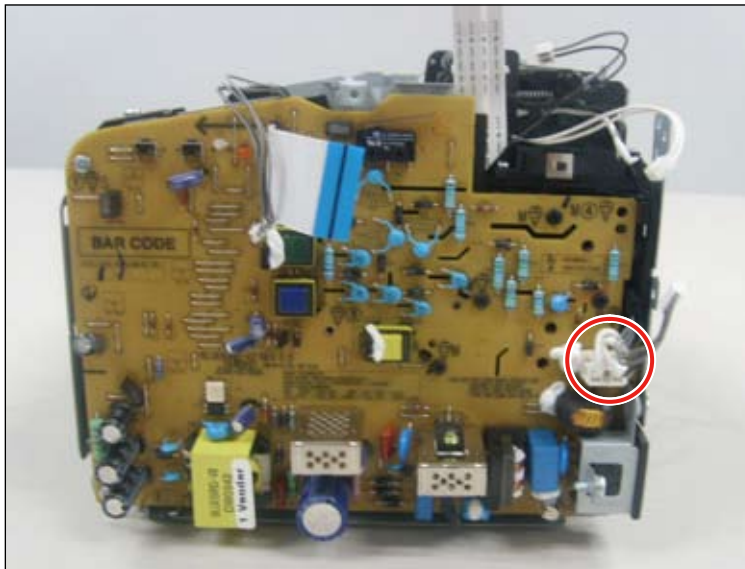

3. Remove 4 screws.
4. Pull the fuser unit to the direction of arrow slightly and release it.

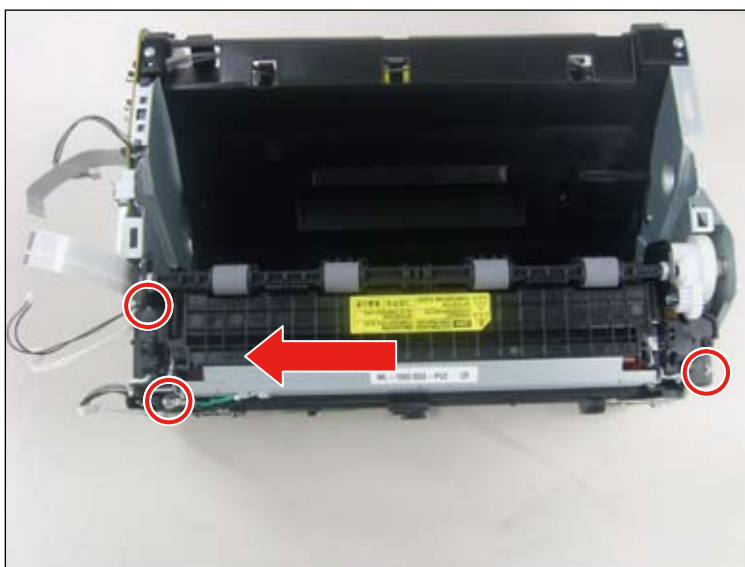

## 3.10 LSU

1. Remove the all covers. (Refer to 3.3~6)
2. Remove 4 screw securing the COVER-LSU and release the main motor harness.
3. Release the COVER-LSU.

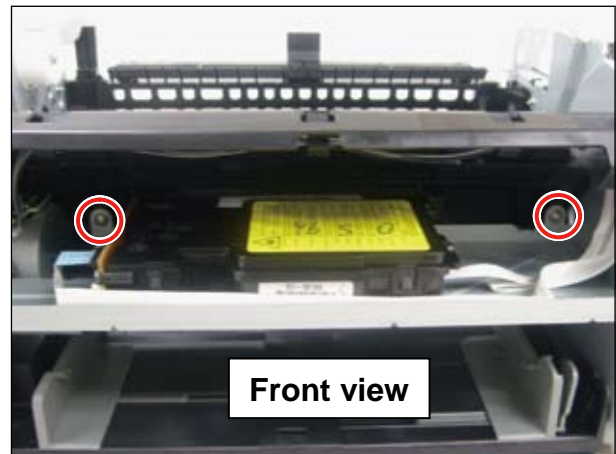
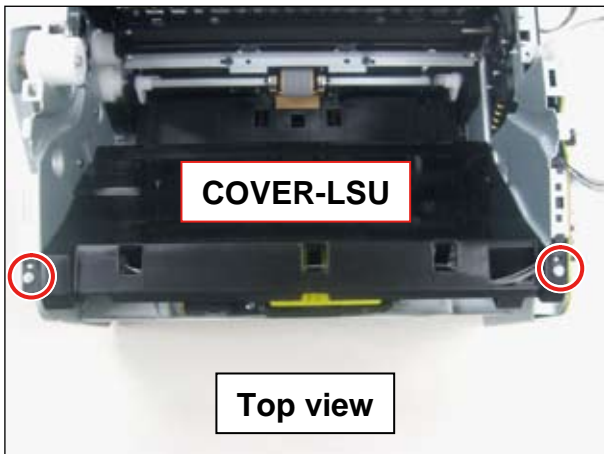

4. Remove 3 screws and 2 flat cables. Release the LSU.



## 3.11 Drive unit

1. Remove the left cover.
2. Remove 3 screws. Release the drive unit.

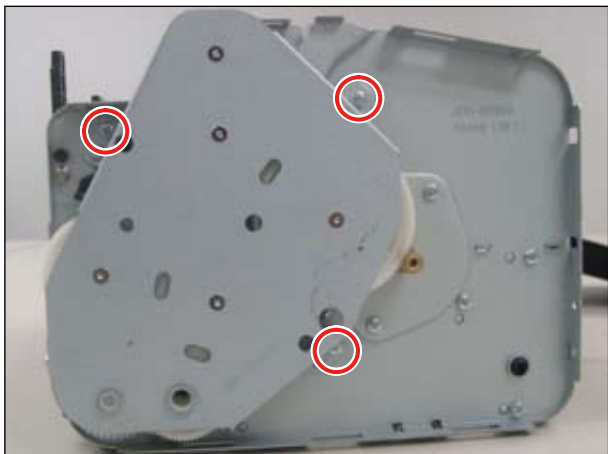

## 3.12 Step motor

1. Remove the drive unit. (Refer to 3.11)
2. Remove 6 screws. Release the left-frame bracket.



### Caution

When reassembling the drive unit, put down the drive unit and assemble the left-frame bracket.

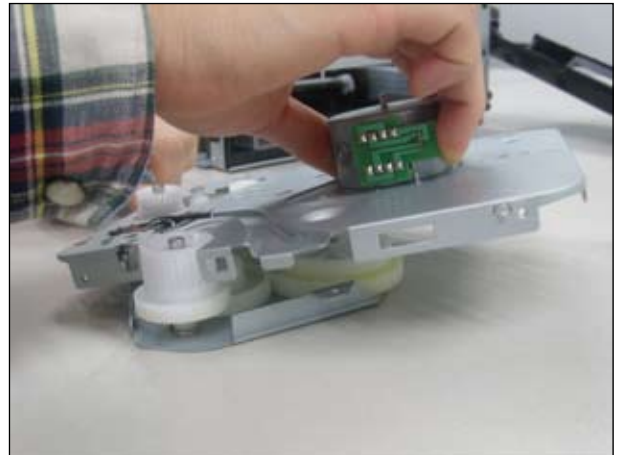

3. Remove 2 screws. Release the step motor.





### 3.13 Pick up roller

1. Open the top cover.
2. Take out the toner cartridge.
3. Push the hinge to the direction of arrow.

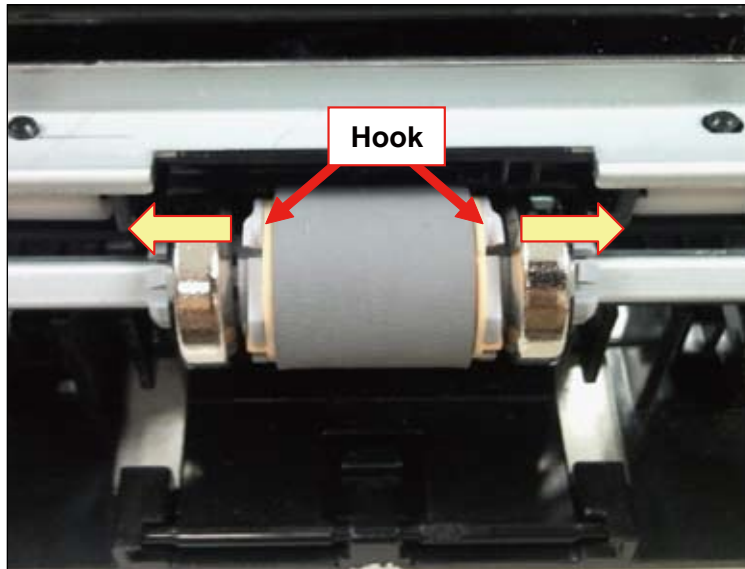

### 3.14 Transfer roller

1. Open the top cover.
2. Take out the toner cartridge.
3. Pull the shaft to the direction of arrow by driver and release the transfer roller.

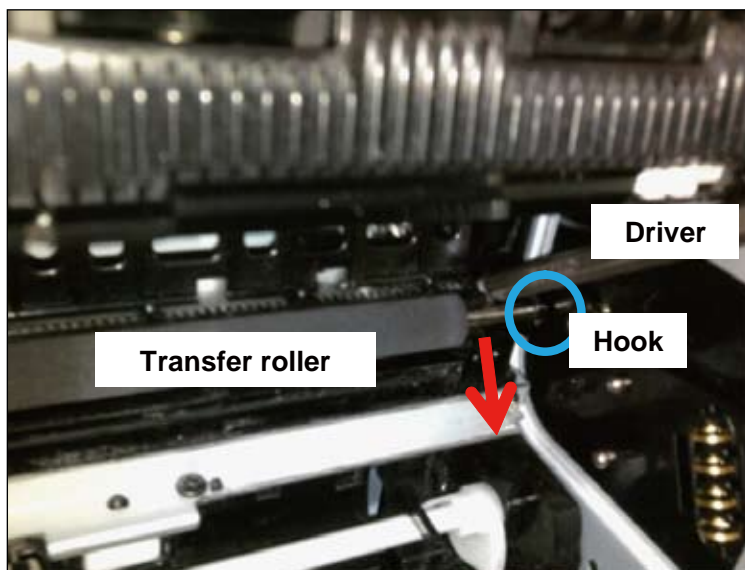

Caution - Don't touch the surface of transfer roller.

## 4. Alignment and Troubleshooting

### 4.1 Alignment and Adjustments

This chapter describes the main functions for servicing the equipment, such as the product maintenance method, image quality proper repair procedures, jam removal procedures, and so on.

#### 4.1.1 Control Panel

This control panel may differ from your machine depending on its model.

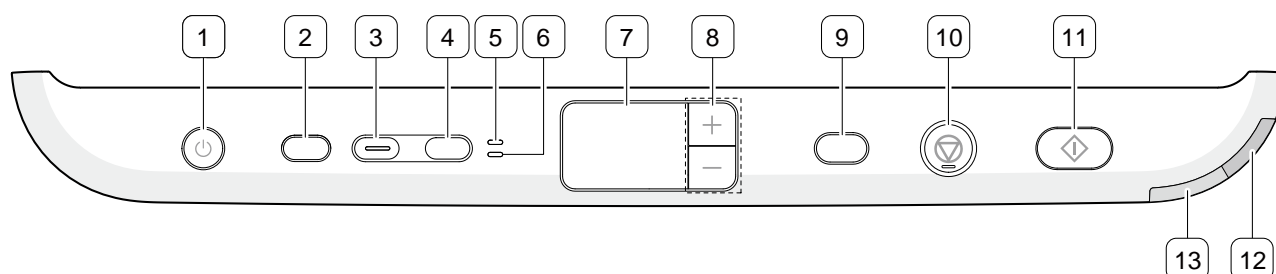

1	<b>Power ( ⏻ )</b>	Allows you to turn the power on or off.
2	<b>Eco Print</b>	Turn the Eco mode on or off.
3	<b>Scan to</b>	Sends scanned data.
4	<b>ID Copy</b>	Allows you to copy both sides the ID card like a driver's license to a single side of paper.
5	<b>Front LED</b>	When the LED lights on, place the front side of an ID card facing down on the scanner glass.
6	<b>Back LED</b>	When the LED lights on, place the back side of an ID card facing down on the scanner glass.
7	<b>Display</b>	Shows the number of pages you want to copy.
8	<b>+/- Buttons</b>	Allows you to increase/decrease the number of page you want to copy.
9	<b>Print Screen (SCX-3200/3205 only)</b>	Prints the displayed screen of your monitor.
	<b>WPS (SCX-3205W(K) only)</b>	Allows you to turn on or off the wireless network connection.
10	<b>Stop/Clear ( ⏹ )</b>	Stops an operation at any time and there are more functions.
11	<b>Start ( ⏻ )</b>	Begins a printing, copying or scanning job depending on which function you are using.
12	<b>Wireless LED (SCX-3205W(K) only)</b>	Shows the current status of the wireless network connection.
13	<b>Status LED</b>	Shows the status of your machine.

## 4.1.2 Understanding the status LED





### ■ Status LED

The color of the LED indicates the machine's current status.

STATUS LED		DESCRIPTION
Off		<ul style="list-style-type: none"> <li>The machine is off-line.</li> <li>The machine is in sleep mode.</li> </ul>
Green	On	<ul style="list-style-type: none"> <li>The machine is in ready mode or warming up.</li> </ul>
	Blinking	<ul style="list-style-type: none"> <li>When the LED blinks slowly, the machine is receiving data from the computer or printing documents.</li> <li>When the LED blinks rapidly, the machine is operating special functions.</li> </ul>
Red	On	<ul style="list-style-type: none"> <li>The inner cover is opened. Close the inner cover completely.</li> <li>There is no paper in the tray. Load paper in the tray.</li> <li>The machine has stopped due to a major error.</li> <li>Your system has some problems. If this problem occurs, contact a service representative.</li> <li>A toner cartridge has almost reached its estimated cartridge life<sup>a</sup>. It is recommended to replace the toner cartridge.</li> </ul>
	Blinking	<ul style="list-style-type: none"> <li>A small amount of toner is left in the cartridge. The estimated cartridge life of toner is close. Prepare a new cartridge for replacement. You may temporarily increase the printing quality by redistributing the toner.</li> <li>The machine is printing in manual feed mode or in manual duplex mode.</li> </ul>
Orange	On	A paper jam has occurred.

a. Estimated cartridge life means the expected or estimated toner cartridge life, which indicates the average capacity of print-outs and is designed pursuant to ISO/IEC 19752. The number of pages produced will be affected by the percent of imaged area of your original. The operating environment, printing interval, media type, and media size, may also affect the number of pages produced by your cartridge. Some amount of toner may remain in the cartridge even when red LED is on and the printer stops printing.

### ■ Wireless LED

WIRELESS LED STATUS		DESCRIPTION
Blue	Off (  )	Wireless network is disconnected.
	On (  )	Wireless network is connected.
	Slowly blinks (  )	The machine starts connecting to a wireless network.
	Quickly blinks (  )	<ul style="list-style-type: none"> <li>The machine is connecting to access point (or wireless router).</li> <li>Wireless network connection is being disconnected.</li> </ul>

## 4.1.3 JAM Removal

### 4.1.3.1 Clearing Paper Jams

If a paper jam occurs, the Status LED on the control panel lights orange. Find and remove the jammed paper.

**!** To avoid tearing the paper, pull the jammed paper out slowly and carefully. Follow the instructions in the following sections to clear the jam.

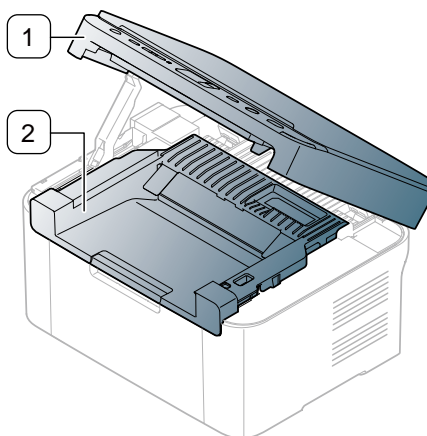

- 1 Scan unit
- 2 Inner cover

#### In tray

1. Open the scan unit first, and then the inner cover.

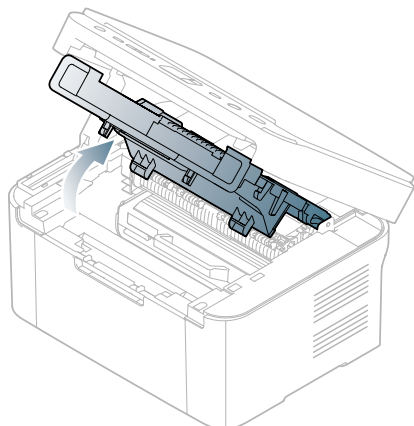
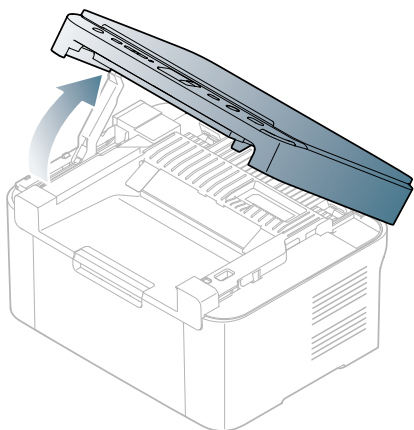

2. Close the inner cover and the scan unit in order. The jammed paper is automatically ejected from the machine. If the paper does not eject, go to the next step.
3. Remove the jammed paper by gently pulling it straight out.

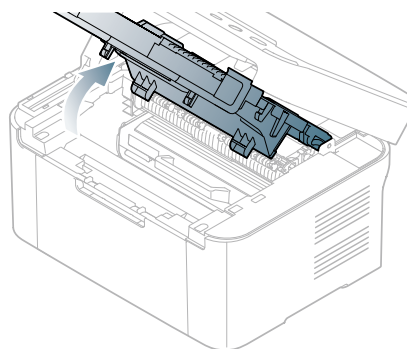

If the paper does not move when you pull, or if you do not see the paper in this area, check inside the machine.

**Inside the machine**

1. Open the scan unit first, and then the inner cover.

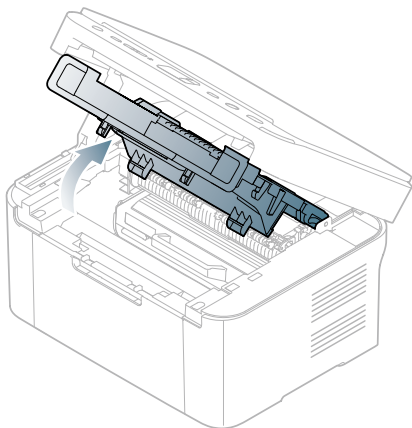
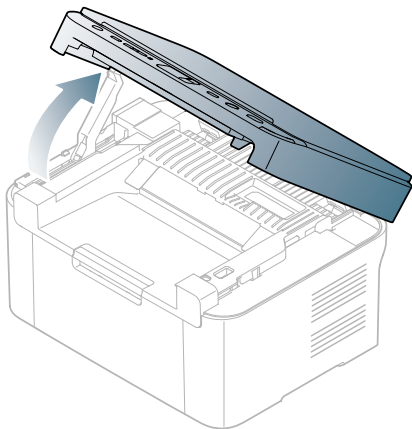

2. Close the inner cover and the scan unit in order. The jammed paper is automatically ejected from the machine. If the paper does not eject, go to the next step.

3. Open the scan unit.

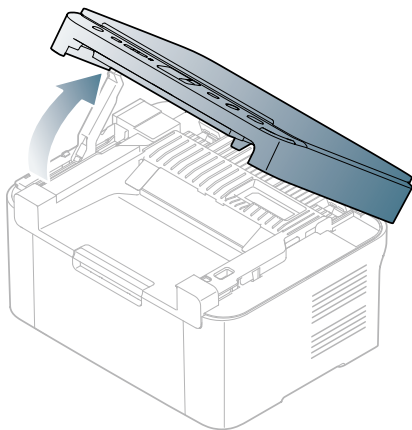

4. Remove the jammed paper by gently pulling it straight out.

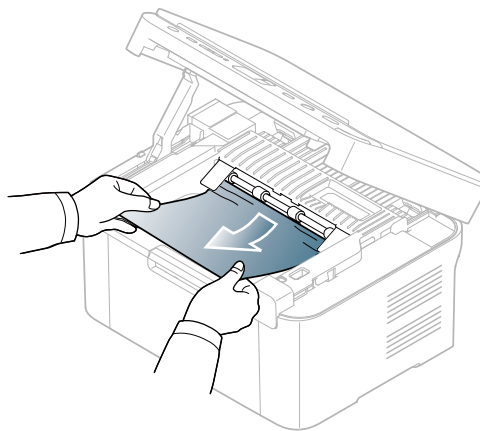

If you do not see the paper in this area, go to the next step.

5. Open the inner cover.

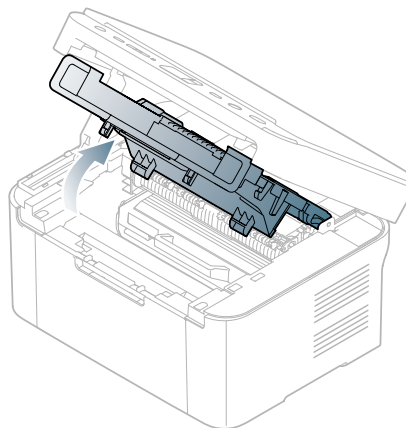

6. Open the fuser unit cover.

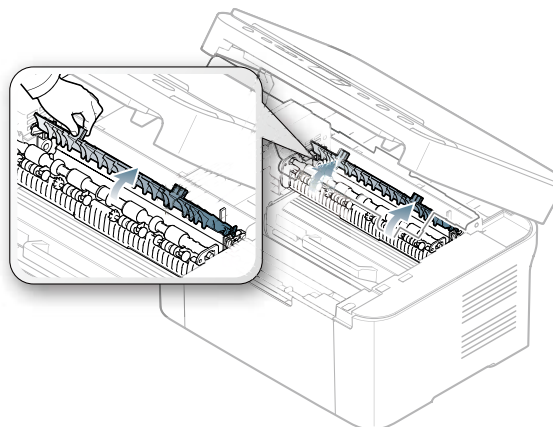

7. Remove the jammed paper by gently pulling it straight out.

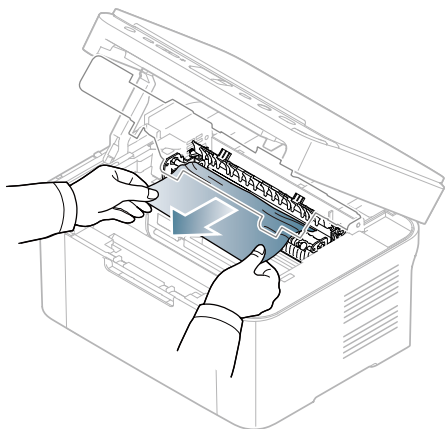

If you do not see the jammed paper, go to the next step.

8. Pull the toner cartridge out.

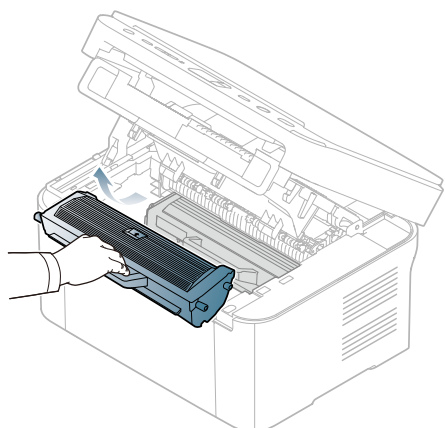

9. Remove the jammed paper by gently pulling it straight out.

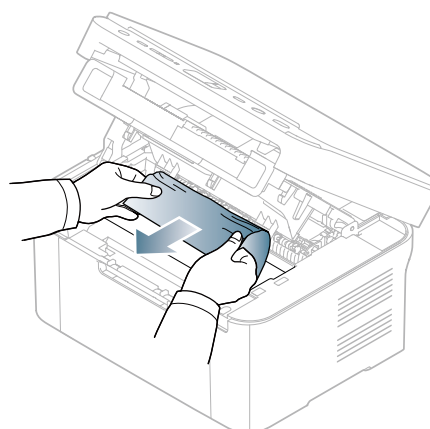

10. Insert the toner cartridge back into the machine.

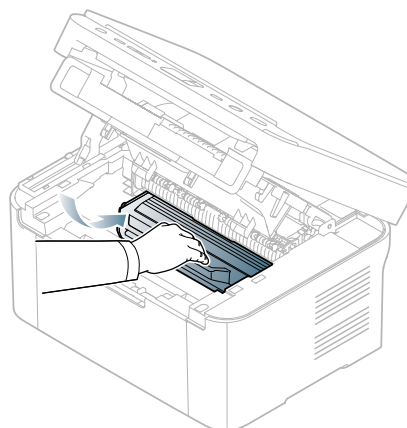

11. Close the inner cover and the scan unit in order. Printing automatically resumes.

## 4.1.4 EDC mode

### 4.1.4.1 Entering the EDC mode

In EDC mode, the technician can check the particular component of the printer are properly functioning

#### ■ Method to enter

1. Connect only one printer to the computer using USB cable.
2. Power up the printer and wait for the printer to finish initializing.
3. Start EDC utility, see page 66.
4. To get out of the EDC Mode, Press the “Exit” button.

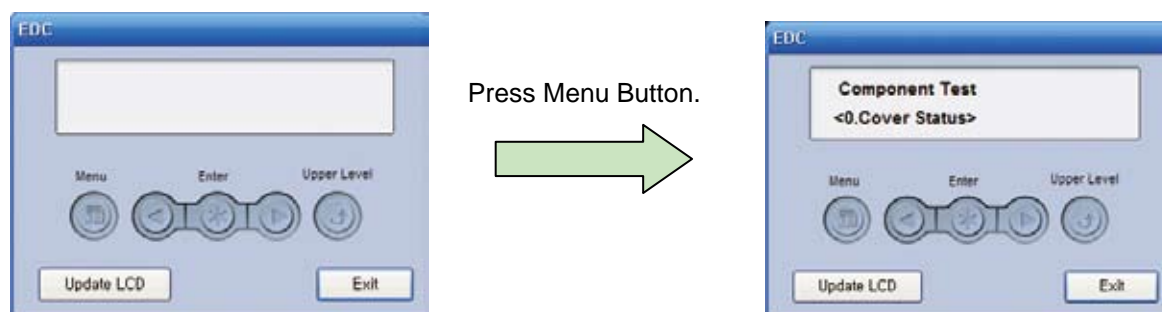

\* Allow 1 second for the printer to process the command from EDC before pressing then next button.

#### ■ Menu Map

0. Check Cover Status
1. Check Sensor Status
2. Test Motor
3. Test Fan
4. Test Clutch & Solenoid
5. Fuser Control
6. LSU Control
7. DEV Control



#### 4.1.4.2 EDC mode menu configuration

##### 0. Cover Status

Item	Description
Front Cover	When the front cover opened, "Open" message display LCD. If the front cover closed, "Closed" message display LCD.

##### 1. Sensor Status

Item	Description
Regi / Feed / Exit Sensor	If actuator is checked by sensor, "With Paper" message will be displayed. if not, "Without Paper" will be displayed.
Empty	If paper exists in the tray, "Present" will be displayed. If not, "Empty" will be.

##### 2. Motor Test

Item	Description
Main Mtr Nor.	If "Enter" button is pushed after "ON" displayed, motor will be run. Main motor will auto - stop after 60 seconds and "OFF" message will be displayed.

##### 3. Fan Test

Item	Description
Fuser Fan	If "Enter" button is pushed after "ON" displayed, fan will be run. Fuser fan will auto - stop after 10 seconds and "OFF" message will be displayed.

##### 4. Clutch Test

Item	Description
Pick up Clutch	When "OK" key is pushed after "ON" message displayed, clutch turn on. pick up clutch will be turn off after 3 seconds and "OFF" message will be displayed.

##### 5. Fuser Ctrl

Item	Description
Temp Control	Fuser on and off. "ON" is selected, fuser will be active and display the fuser temperature [XXX] but "OFF" is selected, fuser will be stop.
Fuser Temp.	Fuser temperature displayed on LCD (example: [170] )

## 6. LSU Control

Item	Description
LD Power	When "Enter" button is pushed after "ON" message displayed, "OFF" message will be displayed after 10 seconds
LSU Motor	If "Enter" button is pushed after "ON" displayed, motor will be run. LSU motor will auto - stop after 10 seconds and "OFF" message will be displayed.
LSU Ready	If "Enter" button is pushed after "ON" displayed, motor will be run. "1" message will be displayed.
Hsync	If "Enter" button is pushed after "ON" displayed, motor will be run. "1" message will be displayed.

## 4.1.5 Tech mode

### 4.1.5.1 Entering the Tech mode

#### ■ Enter Tech mode



Press key continuously in idle mode

Up → Up → Stop → Down → Down → Stop → Stop



After machine entered tech mode, 7 segment is displayed as following figures

#### ■ Exit Tech mode

- Press "Stop / Clear" Key in tech mode
- Power Off/On
- Automatically machine will exit tech mode if user does not press any key in 30 seconds

#### ■ Exceptional case

- We can't enter tech mode while machine is working such as printing/scanning/copying

### 4.1.5.2 Tech mode menu configuration

#### ■ Tech mode menu configuration

Order	LCD	Description
1		Print Usage Counter Report (UC)
2		Print Shading Report (SD) – Shading & Printing
3		Print Supplies Info Report (SI)
4		Print Event Log Report (EL)
5		Print Customer Assistance Report (CA)
6		Print All Report (AR) - In case of shading, machine does not work shading, just print data only
7		Scanner Aging Start (SA) - when you press “stop / clear” key, then it will be stop
8		Factory Memory Clear (FC)
9		Toner Low Level Control

#### ■ Usage Counter Report

We can know customer mostly uses machine for what kind of job and estimates particular unit life status.

Usage Counter Report					Page 1
Model Name		: Samsung SCX-3200 Series			
Machine Serial Number		: 0000-000000000000			
Printer Usage		Print	Copy	Report	Total
Simplex	Mono	0	0	2	2
Total impressions		0	0	2	2
Paper Size (Impressions)			Paper Type (Impressions)		
Letter		: 2	Plain		: 2
Legal		: 0	Thick		: 0
Oficio		: 0	Thin		: 0
Folio		: 0	Bond		: 0
A4		: 0	Transparency		: 0
ISO B5		: 0	Envelope		: 0
JIS B5		: 0	Labels		: 0
Executive		: 0	Cardstock		: 0
A5		: 0	Preprinted		: 0
Envelope Monarch		: 0	Color		: 0
Envelope DL		: 0	Cotton		: 0
Envelope C5		: 0	Recycled		: 0
Envelope No.10		: 0	Archive		: 0
Custom		: 0			

## ■ Shading Report

We can know there is error in scanner device.  
 (For more detail contents, refer to S3-3122 error codes page)

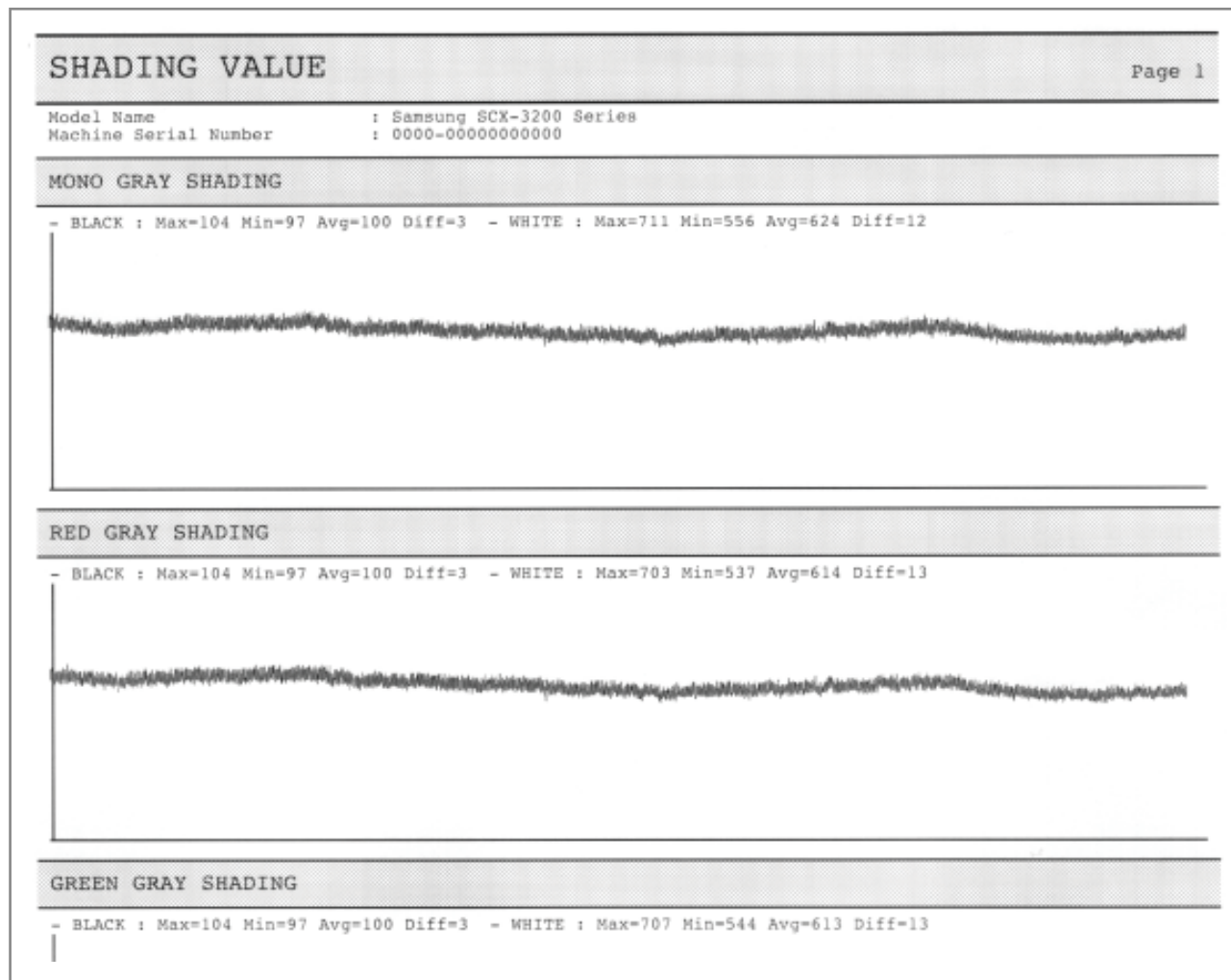

■ Supplies Info Report

We can know consumable unit life status and toner using status.

Supplies Information Report		Page 1
Model Name	: Samsung SCX-3200 Series	
Machine Serial Number	: 0000-00000000000	
General Information		
Total Page Count	: 2	
Platen Scan Page Count	: 1	
Toner Information		Black
Toner Remaining	: 98 %	
Page Count	: 23	
Serial No.	: CRUM-10021750676	
Supplier	: PT166DOM	
Product Date	: 2010.02.17	
Last Used Date	: 2010.02.19	
First Installed Date	: 2010.02.19	
Equivalent Pages Printed	: 39	
(Based on ISO/IEC Standard Page)		
Estimated Pages Remaining	: 2200	
Average Area Coverage	: 8.6%	
Ref. Deve Motor on Time	: 85000	
Deve Motor on Time	: 176	
Ref. Dot Count	: 4915680000	
Dot Count(Remaining)	: 58989600(98%)	
Real Used Dot Count	: 47250300	
Page Count After Worn	: 0	
Replaced Toner Count	: 0	
Company ID	: SAMSUNG	
Supplier ID	: PT166DOM	
Capacity	: 1.5K	
Consumables Information		
Fuser Life	: 2/30000	(Page(s)/Life)
Transfer Roller Life	: 2/30000	(Page(s)/Life)
Pick-up Roller Life	: 2/30000	(Page(s)/Life)
Cassette Holder Pad Life	: 2/30000	(Page(s)/Life)

## ■ Event Log Report

We can know which kinds of errors has occurred and its history.

Event Log Information				Page 1
Model Name		: Samsung SCX-3200 Series		
Machine Serial Number		: 0000-000000000000		
Error Count				
PAPER EMPTY		:	0	
PAPER JAM0 IN TRAY1		:	0	
PAPER JAM1		:	0	
OUT-BIN FULL		:	0	
FUSER OPEN ERROR		:	0	
FUSER HIGH ERROR		:	0	
FUSER LOW ERROR		:	0	
LSU HSYNC ERROR		:	0	
LSU MOTOR ERROR		:	0	
TONER KIT NOT INSTALLED K		:	0	
INVALID TONER KIT K		:	0	
TONER EXHAUSTED REPLACE TONER		:	0	
TONER EMPTY REPLACE TONER		:	0	
TONER LOW		:	0	
COVER OPEN		:	4	
SCANNER LOCKED ERROR		:	3	
SCANNER SHADING ERROR		:	1	
WIRELESS NETWORK IS NOT INSTALLED		:	0	
NETWORK IP ADDRESS CONFLICT		:	0	
a5a5a5a5a5a5a5a5a5a5a5a5a5a5a5a5a596969694				
No	Page	Name	Code	
001	1	COVER OPEN	S2-4110	
002	1	COVER OPEN	S2-4110	
003	1	SCANNER LOCKED ERROR	S3-3121	
004	1	SCANNER SHADING ERROR	S3-3122	
005	1	COVER OPEN	S2-4110	
006	1	SCANNER LOCKED ERROR	S3-3121	
007	1	COVER OPEN	S2-4110	
008	1	SCANNER LOCKED ERROR	S3-3121	

## ■ Customer Assistance Report

It give brief information to know how to memory clear and FW upgrade.

Customer Assistance Report	
Model Name : Samsung SCX-3200 Series	
Machine Serial Number : 0000-000000000000	
Country Setting Procedure	
<ol style="list-style-type: none"> <li>1. Enter Tech Mode</li> <li>2. Select [FC] Menu and Press [START]</li> <li>3. Select a country number and Press [START]</li> </ol>	
F/W Upgrade Procedure	
<ol style="list-style-type: none"> <li>1. Connect a USB Cable from PC to Machine</li> <li>2. Prepare a rom file like 'rom.hd' and 'usblist2.exe' in the same directory                     <ul style="list-style-type: none"> <li>* Type 'usblist2 rom.hd' in DOS mode and Enter</li> <li>C:&gt; usblist2 rom.hd</li> <li>- Start to download a rom file</li> </ul> </li> </ol>	

## ■ Configuration Report

We can check various SW version and current machine setting status.  
In order to print, press more than 2 seconds in idle status and release button when status green LED is blinking slowly.

Configuration Report		Page 1
Model Name	: Samsung SCX-3200 Series	
Machine Serial Number	: 0000-000000000000	
<b>Product Information</b>		
Installed Date	: 2010-05-07	
Memory Size	: 128 MB	
<b>Firmware Versions</b>		
Firmware Version	: V3.00.00.13	Feb-19-2009
Engine Version	: 0.00.12	
PCL5E Version	: PCL5e 6.10 12-30-2009	
SPL Version	: SPL 5.38 12-15-2009	
XHTML-Print Version	: XHTML-Print 0.94.00 02-12-2010	
<b>Quality Control Version</b>		
COPY Version	: COPY_CMS_VERSION_0.3_CCI	
IEM Version	: IEM_CMS_VERSION_0.000.00.000_CCI	
SCAN Version	: SCAN_CMS_VERSION_1.000.00.000_CCI	
<b>Product Setting</b>		
Language	: English	
Sleep Mode	: 5 Min	
<b>Paper Setting</b>		
Media Name	: Tray 1	Paper Type : Plain Paper Paper Size : Letter
<b>Print Setting</b>		
Altitude Adjustment	: Normal	



## ■ Network Configuration Report

We can check wired/wireless network information and setting values.

In order to print, press more than 4 seconds in idle status and release button when status green LED is blinking fast. It just supports wireless machine model.

Network Configuration Report	
Model Name	: Samsung SCX-3200 Series
Machine Serial Number	: 0000-000000000000
Network Information	
<b>General Information</b>	
Host Name	: SEC001599483DD8
Contact	: Administrator
Location	:
MAC Address	: 00:15:99:48:3D:D8
NIC Firmware Version	: V0.05.00(SCX-3200)
Network Connection Status	: Unplugged
<b>TCP/IPv4 Information</b>	
IP Assignment	: STATIC
IP Address	: 10.88.196.47
SubNet Mask	: 255.255.255.0
Default Gateway	: 10.88.196.1
<b>TCP/IPv6 Information</b>	
IPv6 Protocol	: Enabled
Link-Local Address	: FE80::215:99FF:FE48:3DD8/64
Stateless Address	:
Stateful Address	:
Manual Address	:
DHCPv6 Config	: Use DHCP as directed by a router
<b>Raw TCP/IP Printing Information</b>	
Raw TCP/IP Printing	: Enabled
Port Number	: 9100
<b>LPR/LPD Information</b>	
LPR/LPD Protocol	: Enabled
Port Number	: 9100
<b>IPP Information</b>	
IPP Protocol	: Enabled
Printer URI	: http://10.88.196.47:631
Authentication Scheme	: None
<b>SLP Information</b>	
SLP Protocol	: Enabled
Port Number	: 427
<b>mDNS Information</b>	
mDNS Protocol	: Enabled
Port Number	: 5353
<b>SNMP Information</b>	
SNMPv1/v2 Protocol	: Enabled
SNMPv3 Protocol	: Disabled
<b>HTTP Information</b>	
HTTP Protocol	: Enabled
Port Number	: 80
<b>SetIP Information</b>	
SetIP Protocol	: Enabled
Port Number	: 6000
<b>IP Filtering Information</b>	
IPv4 Filtering	: Disabled
IPv6 Filtering	: Disabled
<b>MAC Filtering Information</b>	
MAC Filtering	: Disabled
Wireless Network Information	
<b>General Information</b>	
SSID	: obeng_ap
Operation Mode	: Infrastructure
<b>Status Information</b>	
Link Status	: Not Connected
Link Quality	: No Signal
Current Channel	: 10
<b>WPS Information</b>	
PIN Number	: 43883561

### ■ All Report

Machine automatically print out all kind of report including Configuration and network configuration report.

### ■ Toner Low Level Control

Machine check dot counts every printing cases and store status to non-volatile memory. If remaining dot count reaches below 10%, machine will blinking red status LED.  
The rate of toner low level can be changed using this feature.

1. Select "LC" menu in tech mode
2. Select number using Up/Dn key
  - Available range 1%~30%
3. Select Start Key

## 4.1.6 Upgrade Firmware

### 4.1.6.1 Upgrade firmware using USB port

#### [upgrading preparations]

- USBLIST.exe : Tool which sends firmware data to printer.
- Firmware file to upgrade

#### [Upgrade Procedure]

1. Connect USB cable to printer
2. Open DOS prompt and change path
3. Check preparation exist or not using “dir” command
4. Input command “usblast2.exe <firmware filename>”
5. firmware will be downloaded and machine starts upgrading

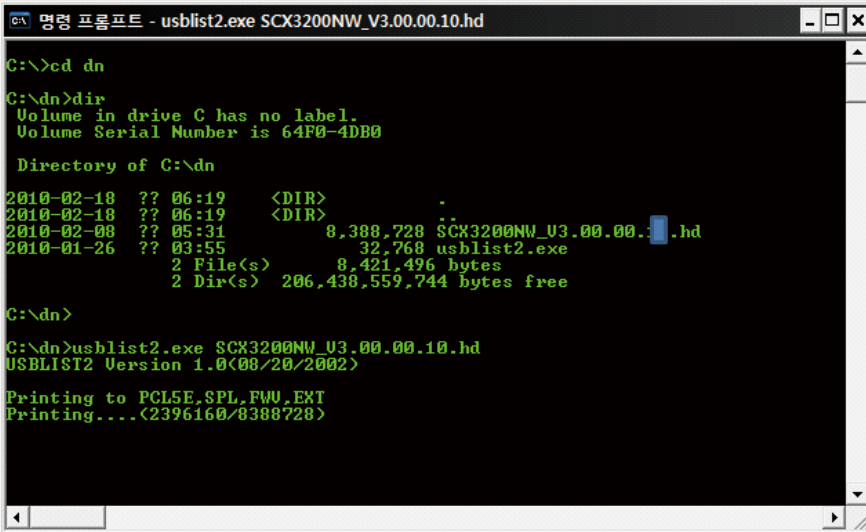

```

C:\>cd dn
C:\dn>dir
Volume in drive C has no label.
Volume Serial Number is 64F0-4DB0

Directory of C:\dn

2010-02-18 ?? 06:19 <DIR>          -
2010-02-18 ?? 06:19 <DIR>          -
2010-02-08 ?? 05:31             8,388,728 SCX3200NW_V3.00.00.10.hd
2010-01-26 ?? 03:55             32,768 usblast2.exe
                2 File(s)      8,421,496 bytes
                2 Dir(s)   206,438,559,744 bytes free

C:\dn>
C:\dn>usblast2.exe SCX3200NW_V3.00.00.10.hd
USBLIST2 Version 1.0(08/20/2002)
Printing to PCL5E,SPL,FWU,EXT
Printing....(2396160/8388728)
  
```

6. At this time, LED of machine is looping until upgrading is completed

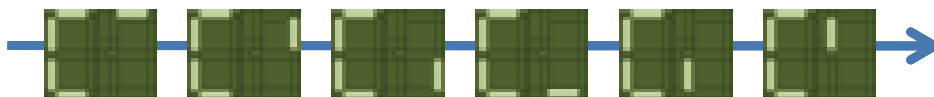

7. When upgrading is completed, machine is automatically re-booting.

### 4.1.6.2 Upgrade firmware using Network

#### [upgrading preparations]

- Wired or Wireless Network connection is established
- Firmware file to upgrade

#### [Upgrade Procedure]

1. Open Web-browser and input IP address of machine

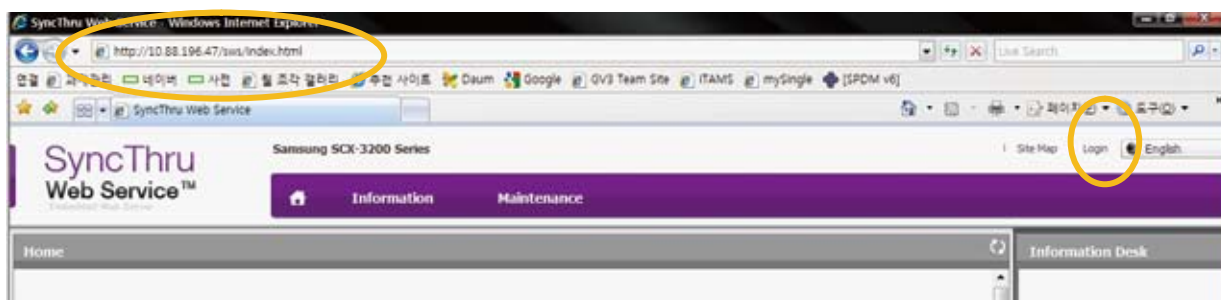

2. Log-in Admin Mode

ID: Admin, PW: sec00000

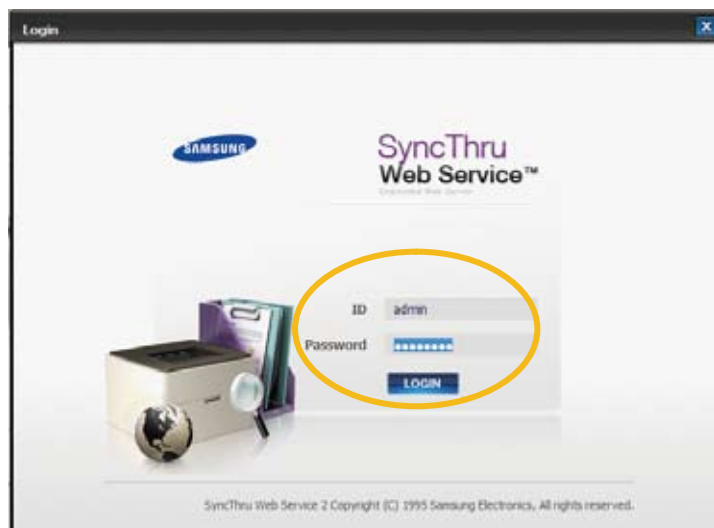

3. Select Maintenance menu and click “upgrade wizard”



4. Select firmware file using “browser” button and press next button.

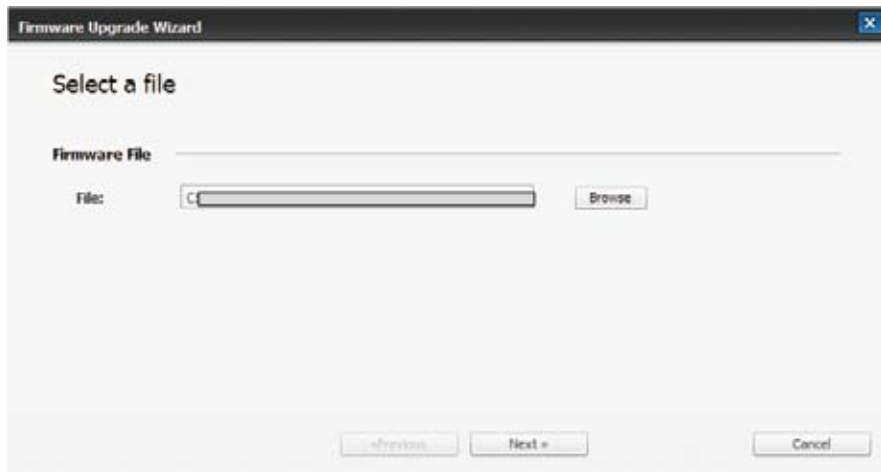

5. SyncThru will check verify firmware file and compare version and press next button.



6. Machine starts upgrading. SyncThru will return home page after upgrading is completed.

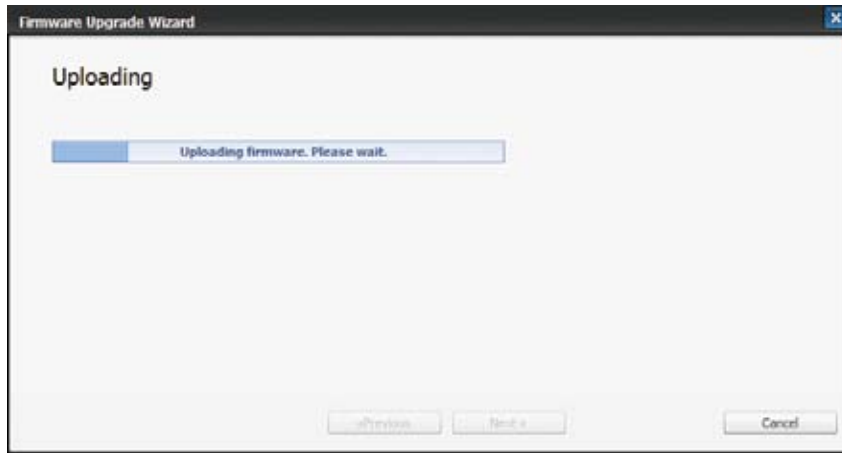

### 4.1.6.3 Using SyncThru Web Service (SWS)

SWS is an embedded web server in the machine. This web server informs you of machine configuration, version, status and allows you to customize the machine's settings. You can connect this server via wired and wireless network using your web browser in the remote place.

#### Connecting preparations

- Wired or Wireless Network connection is established.
- Web Browser (Ex> Internet Explorer) Program on your PC network connected

#### SWS overview

SyncThru Web Service (SWS)

- accepts HTTP request via port 80 as normal web servers.
- provides interface to users information of networked printers and allow to configure the setting of printers
- is able to provide more complicated options than Local UI for printer configuration

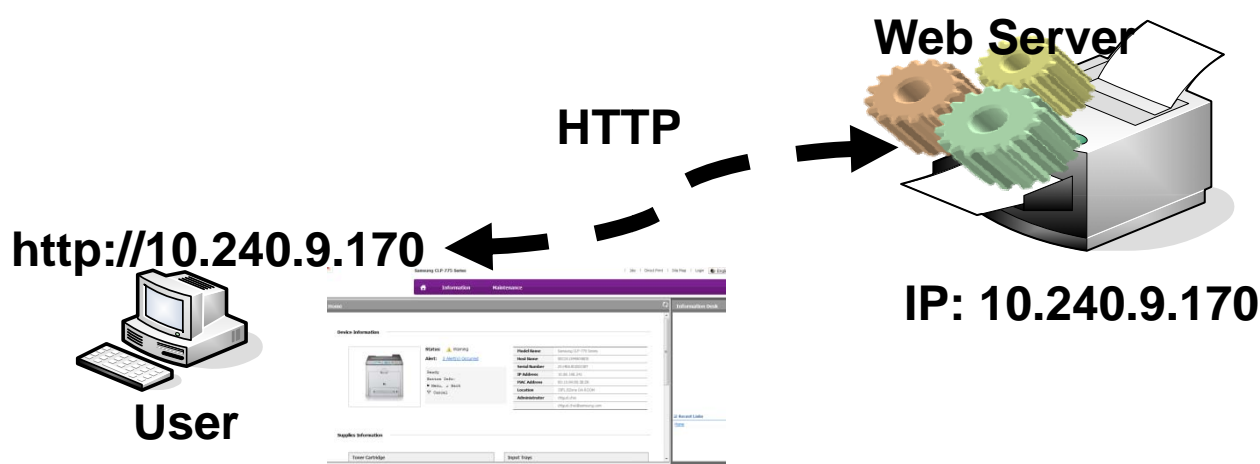

#### Connection Procedure

- 1) Open the Web-browser and input IP address of machine. Click "Login".
- 2) Log-in Admin Mode. (ID: admin, PW: sec00000)
- 3) Select pages to check the configuration and customize the settings

#### Caution

Please, change SWS Default ID and Password for system security in case of your first connection.

#### Note:

If the machine supports 'Direct Print', you can enable this function using the SWS menu. The default configuration is 'Disabled' for your security.

Firstly, you have to login to SWS.

- 1) Click 'Direct Print Configuration' in the pop up windows when clicking 'Direct Print'
- 2) In the 'Services' Menu, check 'Direct Print'.

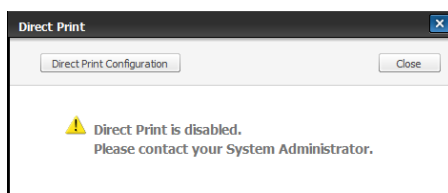

Or,

- 1) Click 'System Security' in the 'Security' menu.
- 2) Select 'Feature Management' in the left frame.
- 3) In the 'Services' Menu, check 'Direct Print'.



### 4.1.7 Periodic Defective Image

If an image defects appears at regular intervals on the printed-paper, it is due to a faulty or damaged roller. Refer to the table below and check the condition of the appropriate roller.

Roller	Period (mm)	Phenomenon	Defective part
OPC Drum	62.9mm	White and Black Spots	Toner Cartridge
Developing Roller	35.1mm	White spot, Horizontal black band	
Charging Roller	26.7mm	Black Spot and line and periodic band	
Supply Roller	47mm	Periodic Band by little difference of density	
Transfer Roller	39.2mm	Ghost, Damaged image by abnormal transfer	Transfer roller
Pressure Roller	75.4mm	Background	Fuser
Fusing Roller	77.5mm	Black spot and image ghost	

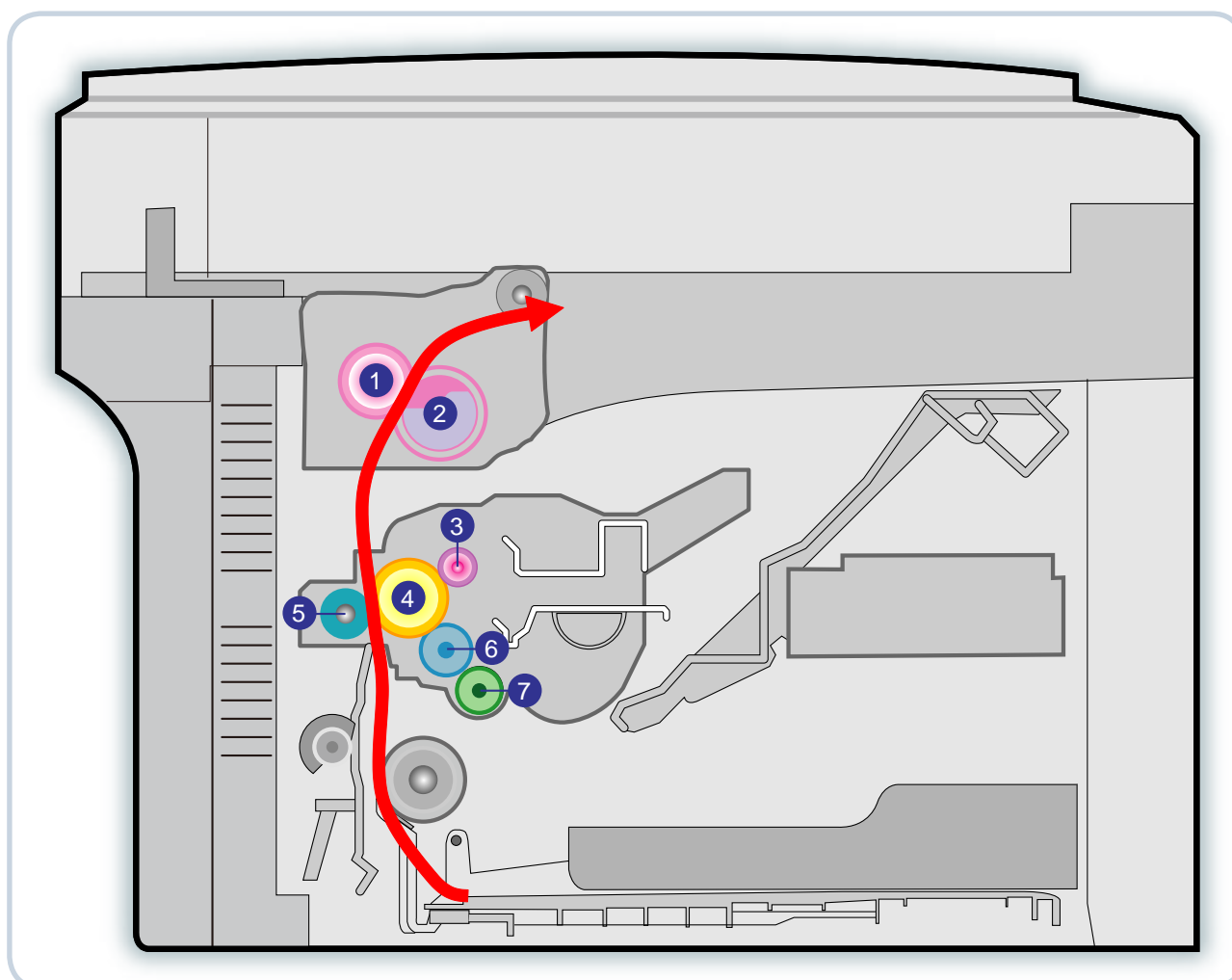

1	Pressure roller	5	Transfer roller
2	Heat roller	6	Deve roller
3	Charge roller	7	Supply roller
4	OPC		

## 4.2 Troubleshooting

### 4.2.1 Procedure of Checking the Symptoms

Before attempting to repair the printer first obtain a detailed description of the problem from the customer.

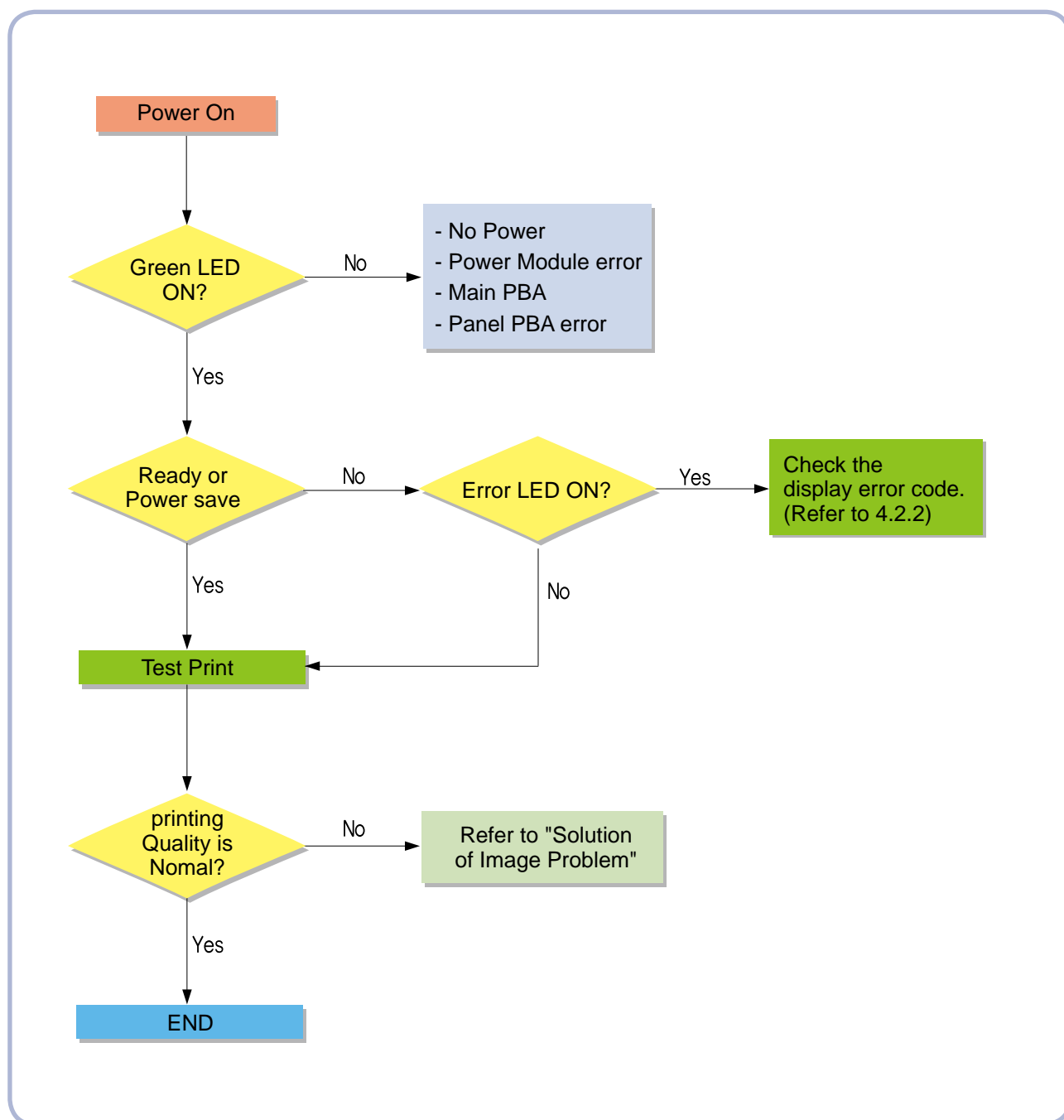

## 4.2.2 Error code and troubleshooting

### 4.2.2.1 Display Error Code using key combination

#### ■ Enter Error Code Display Mode

In idle mode, press key as following sequence:  
Power → Up → Down → Power → Power

#### ■ Exit Error Code Display Mode

There are two kinds of mode to exit error code display mode.

1. Press cancel key in error code display mode
2. Automatically return to idle mode after display all error codes

#### ■ Error Code Display Procedure

When you enter error code display mode, machine will display error code as follows:

First Code 2 Bytes (XH XL) → Second Code 2 Bytes (Y0 Y1) → Third Code 2 Bytes(Y2 Y3 )

- Each data interval time is 2 seconds.
- Error code repeats 3 times for one error code
- If machine has no error, machine just blink "00" LED one time.
- If machine has multiple error codes, it will display each by each

#### ■ Error Code Character

Because machine has restriction to display characters of error codes, following information will be help to understand error codes.

Class 1	Char.	Example
Actuators		A1 → 12 → 10 (Fuser Motor Unexpected Operation) (Blue MT is not used)
Consumables		C1 → 11 → 10 (Toner Low)
Media Handling System Option		H1 → 11 → 11 (HCF Paper Jam) (Blue MT is not used)
Medial Handling System		M1 → 51 → 12 (Tray 1 Paper Empty)
Peripheral System		Not defined yet.
System		S2 → 41 → 10 (Cover Open)
Marker Units		U1 → 21 → 13 (Fuser Low Error)

#### 4.2.2.2 Error code list



Error Code	Error Message	Troubleshooting Page
C1-1110	Prepare new toner cartridge.	4-25 page
C1-1120	Replace with new toner cartridge.	4-26 page
C1-1130	End of life, Replace with new toner cartridge.	4-27 page
C1-1411	Toner cartridge is not installed. Install the cartridge.	4-28 page
C1-1512	Toner cartridge is not compatible. Check user's guide.	4-29 page
M1-1713	Paper jam in tray.	4-30 page
M1-5712	Paper is empty in tray. Load paper.	4-31 page
M2-1114	Paper jam inside of machine.	4-32 page
M3-2130	Out-Bin Full	4-33 page
S2-4110	Door is open. Close the door.	4-34 page
S3-3121	Scanner Locked Error	4-35 page
S3-3122	Scanner Shading Error	4-36 page
S6-3121	Wireless Network not installed	4-37 page
S6-3123	IP Address conflict	4-38 page
U1-2113	Fuser Unit Failure #U1-2113. Please turn off then on.	4-39 page
U1-2131	Fuser Unit Failure #U1-2131. Please turn off then on.	4-40 page
U1-2141	Fuser Unit Failure #U1-2141. Please turn off then on.	4-41 page
U2-5111	Black LSU Unit Failure: #U2-5111. Please turn off then on.	4-42 page
U2-5113	Black LSU Unit Failure: #U2-5113. Please turn off then on.	4-43 page

### 4.2.2.3 Troubleshooting for error code

<ul style="list-style-type: none"><li>● <b>Code :</b> C1-1110</li></ul>	<ul style="list-style-type: none"><li>● <b>Error message :</b> Prepare new toner cartridge.</li></ul>
<ul style="list-style-type: none"><li>● <b>Symptom / Cause :</b>  A small amount of toner is left in the cartridge. Status LED : Red blinking.</li></ul>	
<ul style="list-style-type: none"><li>● <b>Troubleshooting method :</b>  1. Turn the machine off and turn it on again.  2. Print the supply information report.  Check the life remaining of the toner cartridge. (under 10% remaining) If its life is at the end, turn the machine off and replace the toner cartridge with new one.  ** Supply information report can be available in tech mode. In order to enter tech mode, please refer to 4.1.5</li></ul>	
<ul style="list-style-type: none"><li>● <b>Replacement part</b></li></ul>	

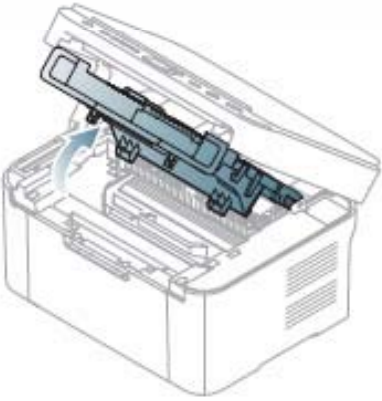

<ul style="list-style-type: none"> <li>● <b>Code :</b> C1-1120</li> </ul>	<ul style="list-style-type: none"> <li>● <b>Error message :</b> Replace with new toner cartridge.</li> </ul>
<ul style="list-style-type: none"> <li>● <b>Symptom / Cause :</b>  A toner cartridge has almost reached its estimated cartridge life. Status LED – Red is on.</li> </ul>	
<ul style="list-style-type: none"> <li>● <b>Troubleshooting method :</b>  1. Turn the machine off and turn it on again.  2. Print the supply information report.  Check the life remaining of the toner cartridge. If its life is at the end, turn the machine off and replace the toner cartridge with new one.  ** Supply information report can be available in tech mode. In order to enter tech mode, please refer to 4.1.5</li> </ul>	
<ul style="list-style-type: none"> <li>● <b>Replacement part</b></li> </ul>	

<ul style="list-style-type: none"> <li>● <b>Code :</b> C1-1130</li> </ul>	<ul style="list-style-type: none"> <li>● <b>Error message :</b> End of life, Replace with new toner cartridge.</li> </ul>
<ul style="list-style-type: none"> <li>● <b>Symptom / Cause :</b>  The toner cartridge is at the end of its life. Status LED – Red is on.</li> </ul>	
<ul style="list-style-type: none"> <li>● <b>Troubleshooting method :</b>  1. Turn the machine off and turn it on again.  2. Print the supply information report.  Check the life remaining of the toner cartridge. If its life is at the end, turn the machine off and replace the toner cartridge with new one.  ** Supply information report can be available in tech mode. In order to enter tech mode, please refer to 4.1.5</li> </ul>	
<ul style="list-style-type: none"> <li>● <b>Replacement part</b></li> </ul>	



<ul style="list-style-type: none"> <li>● <b>Code :</b> C1-1411</li> </ul>	<ul style="list-style-type: none"> <li>● <b>Error message :</b> Toner cartridge is not installed. Install the cartridge.</li> </ul>
<ul style="list-style-type: none"> <li>● <b>Symptom / Cause :</b></li> </ul> <p>The data of CRUM is not detected.</p> <ol style="list-style-type: none"> <li>1. Toner cartridge is not placed in the set.</li> <li>2. Physical obstacle is jamming the electronic signal through the modular jack.</li> <li>3. The signal from set is not proper.</li> </ol>	
<ul style="list-style-type: none"> <li>● <b>Troubleshooting method :</b></li> </ul> <ol style="list-style-type: none"> <li>1. Open the scan unit.</li> </ol>  <ol style="list-style-type: none"> <li>2. Open the inner cover.</li> </ol>  <ol style="list-style-type: none"> <li>3. Insert the toner cartridge into the machine.</li> </ol> 	
<ul style="list-style-type: none"> <li>● <b>Replacement part</b></li> </ul>	

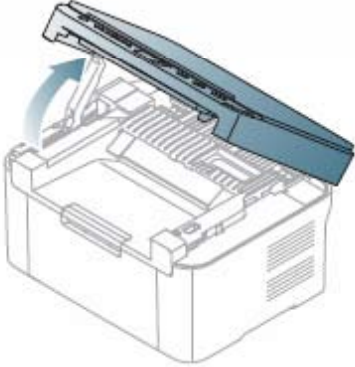
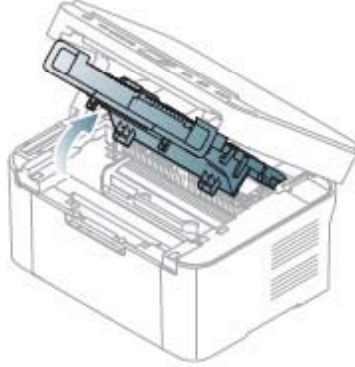

<ul style="list-style-type: none"> <li>● <b>Code :</b> C1-1512</li> </ul>	<ul style="list-style-type: none"> <li>● <b>Error message :</b> Toner cartridge is not compatible. Check user's guide</li> </ul>
<ul style="list-style-type: none"> <li>● <b>Symptom / Cause :</b>  Toner cartridge is not compatible. Machine doesn't print.</li> </ul>	
<ul style="list-style-type: none"> <li>● <b>Troubleshooting method :</b>   <ol style="list-style-type: none"> <li>1. Print the supply information report. Check information of the toner cartridge.</li> <li>2. If the toner cartridge is not a Samsung genuine toner cartridge, replace with new one.</li> </ol> <p>** Supply information report can be available in tech mode. In order to enter tech mode, please refer to 4.1.5.</p> </li> </ul>	
<ul style="list-style-type: none"> <li>● <b>Replacement part</b></li> </ul>	

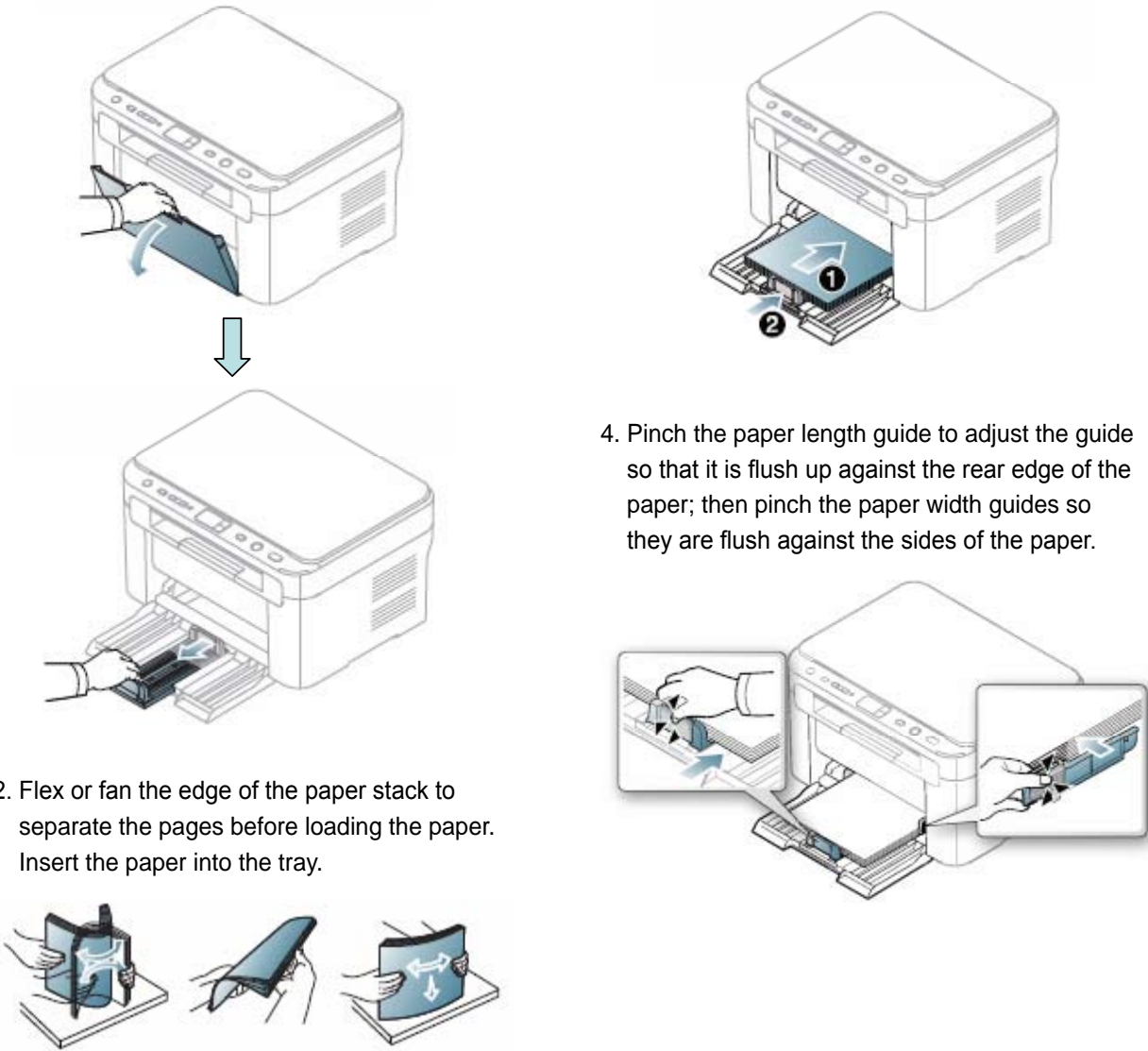
<ul style="list-style-type: none"> <li>● <b>Code :</b> M1-1713</li> </ul>	<ul style="list-style-type: none"> <li>● <b>Error message :</b> Paper jam in tray 1.</li> </ul>
<ul style="list-style-type: none"> <li>● <b>Symptom / Cause :</b></li> </ul> <p>Paper transport jam. (paper Input section)</p> <ul style="list-style-type: none"> <li>- The paper has not reached the tray1 feed sensor within predetermined time after pick up.</li> <li>- Status LED : Orange color is on.</li> </ul>	
<ul style="list-style-type: none"> <li>● <b>Troubleshooting method :</b></li> </ul> <p>JAM in the tray</p> <ol style="list-style-type: none"> <li>1. Open the scan unit first and then the inner cover.</li> </ol>  <ol style="list-style-type: none"> <li>2. Close the inner cover and the scan unit in order. The jammed paper is automatically ejected from the machine.</li> </ol>  <ol style="list-style-type: none"> <li>3. If the paper does not eject, remove the jammed paper by gently pulling it straight out.</li> </ol> 	
<ul style="list-style-type: none"> <li>● <b>Replacement part</b></li> </ul>	

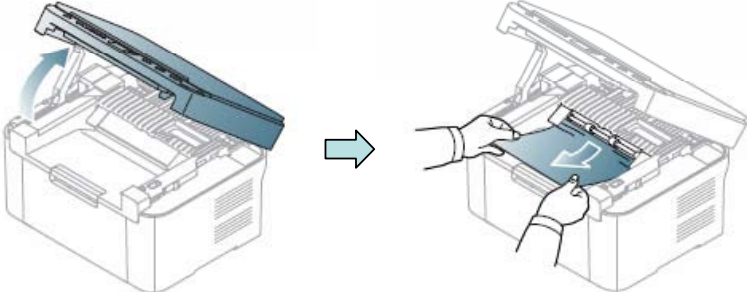
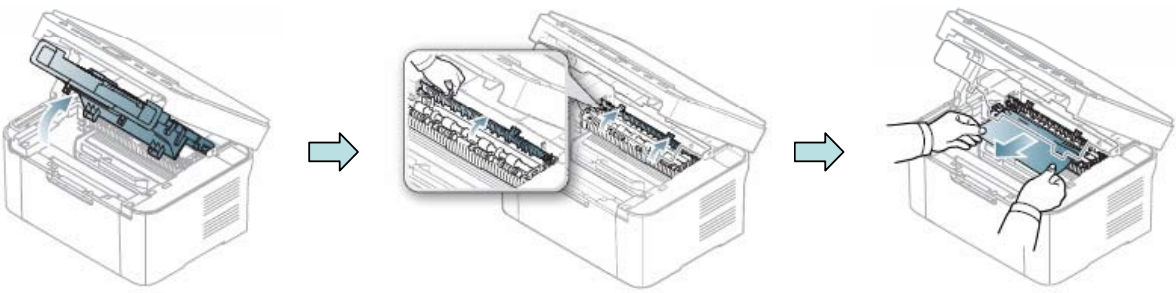
<p>● <b>Code :</b> M1-5712</p>	<p>● <b>Error message :</b> Paper is empty in tray 1 Load paper.</p>
<p>● <b>Symptom / Cause :</b></p> <p>There is no paper in the tray. Status LED –Red color is on.</p>	
<p>● <b>Troubleshooting method :</b></p> <ol style="list-style-type: none"> <li>1. Open front door and pinch the paper length guide and pull it out to extend the tray.</li> <li>2. Flex or fan the edge of the paper stack to separate the pages before loading the paper. Insert the paper into the tray.</li> <li>3. Load paper with the print side facing up. Make sure that all four corners are flat in the tray.</li> <li>4. Pinch the paper length guide to adjust the guide so that it is flush up against the rear edge of the paper; then pinch the paper width guides so they are flush against the sides of the paper.</li> </ol> 	
<p>● <b>Replacement part</b></p>	

<p>● <b>Code :</b> M2-1114</p>	<p>● <b>Error message :</b> Paper jam in tray 1.</p>
<p>● <b>Symptom / Cause :</b></p> <p>Paper transport jam. (paper Input section)</p> <ul style="list-style-type: none"> <li>- The paper has not reached the tray1 feed sensor within predetermined time after pick up.</li> <li>- Status LED : Orange color is on.</li> </ul>	
<p>● <b>Troubleshooting method :</b></p> <ol style="list-style-type: none"> <li>1. Open the scan unit.</li> <li>2. Remove the jammed paper by gently pulling it straight out.</li> </ol>  <p>If you do not see the paper in this area, go to the next step.</p> <ol style="list-style-type: none"> <li>1. Open the inner cover.</li> <li>2. Open the fuser unit cover.</li> <li>3. Remove the jammed paper by gently pulling it straight out.</li> </ol>  <p>If you do not see the jammed paper, go to the next step.</p> <ol style="list-style-type: none"> <li>1. Pull the toner cartridge out and remove the jammed paper by gently pulling it straight out.</li> <li>2. Insert the toner cartridge back into the machine.</li> <li>3. Close the inner cover and the scan unit in order. Printing automatically resumes.</li> </ol> 	
<p>● <b>Replacement part</b></p>	

<ul style="list-style-type: none"> <li>● <b>Code :</b> M3-2130</li> </ul>	<ul style="list-style-type: none"> <li>● <b>Error message :</b> Out-Bin Full.</li> </ul>
<ul style="list-style-type: none"> <li>● <b>Symptom / Cause :</b></li> </ul> <p>Too much paper in output bin tray or the bin full sensor actuator or sensor is defective. Status LED – Red is on. Printer does not print</p>	
<ul style="list-style-type: none"> <li>● <b>Troubleshooting method :</b></li> </ul> <p>1. Remove paper from the output tray. The machine resumes printing.</p> <p>Machine can hold up to 50 sheets (80 g/m<sup>2</sup>) of plain paper. In order to prevent Out-bin full error again, use output tray guide such as following picture.</p> <div data-bbox="513 884 1093 1612" data-label="Image"> <p>The image contains two parts. The top part is a perspective view of a printer with a sheet of paper emerging from its output tray. The bottom part is a close-up diagram of the output tray area. It shows a blue output tray guide being inserted into a slot on the side of the printer. The diagram is numbered 1 and 2, indicating the steps for inserting the guide. Step 1 shows the guide being pushed into the slot, and step 2 shows it fully seated.</p> </div>	
<ul style="list-style-type: none"> <li>● <b>Replacement part</b></li> </ul>	

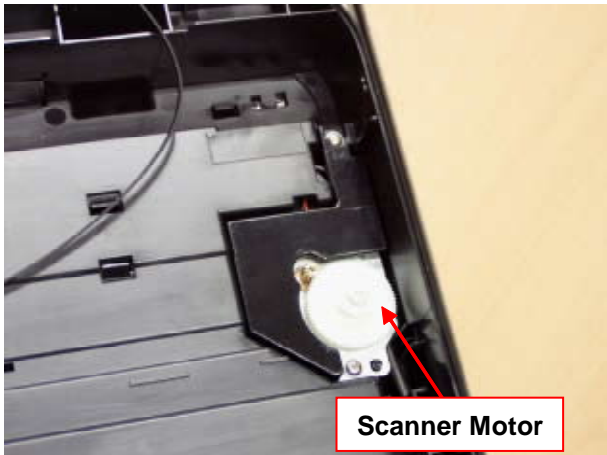

<ul style="list-style-type: none"> <li>● <b>Code :</b> S2-4110</li> </ul>	<ul style="list-style-type: none"> <li>● <b>Error message :</b> Door is open. Close the door.</li> </ul>
<ul style="list-style-type: none"> <li>● <b>Symptom / Cause :</b>  door is open or door sensor is defective Status LED – Red is on</li> </ul>	
<ul style="list-style-type: none"> <li>● <b>Troubleshooting method :</b>  1. Check whether the door is closed perfectly.  2. Check the cover open switch on the HVPS is operated properly. If it is defective, replace the HVPS board.</li> </ul> <div data-bbox="185 857 825 1337" data-label="Image"> <p>The image shows a top-down view of a brown HVPS (High Voltage Power Supply) board. It is populated with numerous components including capacitors, resistors, integrated circuits, and a transformer. A red arrow points from a white text box labeled 'Cover Open Switch' to a small black component on the board.</p> </div>	
<ul style="list-style-type: none"> <li>● <b>Replacement part</b></li> </ul>	

<ul style="list-style-type: none"><li>● <b>Code :</b> S3-3121</li></ul>	<ul style="list-style-type: none"><li>● <b>Error message :</b> Scanner locked error.</li></ul>
<ul style="list-style-type: none"><li>● <b>Symptom / Cause :</b>  The scanner can't work properly. When moving the scanner, an abnormal home position checking of the sensor is occurred. Home position could not be checked because of abnormal symptoms or stop of scan motor stall.</li></ul>	
<ul style="list-style-type: none"><li>● <b>Troubleshooting method :</b>  1. Power Off/On  2. Check situation is same or not. usually scanner locked error would be cleared.  3. If scanner locked error is still not cleared, check if the home sensor or scanner motor is operated properly.</li></ul> <div data-bbox="185 916 794 1368"></div>	
<ul style="list-style-type: none"><li>● <b>Replacement part</b></li></ul>	

<ul style="list-style-type: none"> <li>● <b>Code :</b> S3-3122</li> </ul>	<ul style="list-style-type: none"> <li>● <b>Error message :</b> Scanner Shading Error.</li> </ul>
<ul style="list-style-type: none"> <li>● <b>Symptom / Cause :</b></li> </ul> <p>Machine does not copy properly. (it can be print white paper) /Scanner can't make shading data because of following reason:</p> <ul style="list-style-type: none"> <li>- AFE detection is failed</li> <li>- Shading check sum is failed</li> <li>- Scanner CIS is defective</li> <li>- Scanner Motor not working</li> </ul>	
<ul style="list-style-type: none"> <li>● <b>Troubleshooting method :</b></li> </ul> <ol style="list-style-type: none"> <li>1. Enter tech mode. (refer to 4.1.5)</li> <li>2. Select "SD" menu using Up/Dn key.</li> <li>3. Press Start Key. Shading report will be printed such as below images after machine starting scan shading.</li> <li>4. Check shading report if result of waveform for each color is irregular or very low level, try again 2~3. if result is still produced even though try again, change CIS or main board.</li> </ol> <p>※ Shading normal result</p> <div style="display: flex; align-items: flex-start;"> <div style="flex: 1;">  </div> <div style="flex: 1; padding-left: 20px;"> <p><b>Caution</b></p> <p>Actually, there are two kinds of method to print shading report. One is using "SD" menu, the other is using "AA" menu (All Report). As soon as machine is booting up, if you choice second one menu(AA), report is printed without shading. At this time, result is shown only black shading.</p> </div> </div>	
<ul style="list-style-type: none"> <li>● <b>Replacement part</b></li> </ul>	

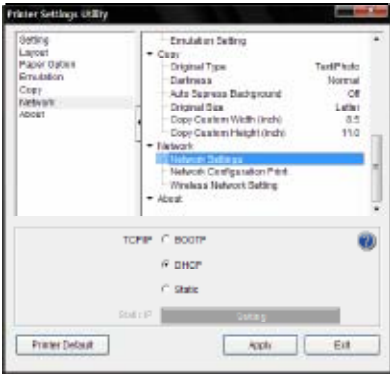

<ul style="list-style-type: none"> <li>● <b>Code :</b> S6-3121</li> </ul>	<ul style="list-style-type: none"> <li>● <b>Error message :</b> Wireless Network not installed.</li> </ul>
<ul style="list-style-type: none"> <li>● <b>Symptom / Cause :</b>  Machine does not detect wireless network card even though card is connected physically. This error is occurred when machine booting up.</li> </ul>	
<ul style="list-style-type: none"> <li>● <b>Troubleshooting method :</b>   <ol style="list-style-type: none"> <li>1. Check Network configuration Report.</li> <li>2. Check wireless card connector is inserted to socket well.</li> <li>3. Replace wireless card module to new one.</li> </ol>   <ul style="list-style-type: none"> <li>※ Reference If wired network cable is connected, wireless does not work even though all of setting is completed and it has no H/W errors. Please check it without wired network cable.</li> </ul> </li> </ul>	
<ul style="list-style-type: none"> <li>● <b>Replacement part</b></li> </ul>	

<ul style="list-style-type: none"> <li>● <b>Code :</b> S6-3123</li> </ul>	<ul style="list-style-type: none"> <li>● <b>Error message :</b> IP address conflict.</li> </ul>
<ul style="list-style-type: none"> <li>● <b>Symptom / Cause :</b>  Machine IP address is conflict to other machine. Machine can't print data from Host PC. (Copy/Report can work)</li> </ul>	
<ul style="list-style-type: none"> <li>● <b>Troubleshooting method :</b>  Change IP address.  ** IP Change Method  1. Connect USB 2. Execute PSU 3. Select Network Configuration Menu 4. Change IP 5. Press "adapt" button</li> </ul> <div style="display: flex; justify-content: space-around; align-items: center;">  <span style="font-size: 2em;">→</span>  <span style="font-size: 2em;">→</span>  </div>	
<ul style="list-style-type: none"> <li>● <b>Replacement part</b></li> </ul>	

<b>• Code :</b> U1-2113	<b>• Error message :</b> Fuser Unit Failure #U1-2113 : Turn off then on.
<b>• Symptom / Cause :</b>  Fuser Unit is transferred Power.	
<b>• Troubleshooting method :</b>  1. Turn the machine off and turn it on again.  2. Check the following :  A. Check the power voltage of the fuser unit. (110V, 220V) B. Check if the Heat lamp is broken. C. Check if the AC connection of Heat lamp is disconnected or contaminated. D. Check if the thermostat is blown. E. Check if there is any jammed paper in fuser unit. F. Check if the power voltage is normal. (Is the voltage during the operation $\pm 10\%$ of the rated voltage?)  3. If the problem persists, replace the fuser unit.  4. If the problem persists after replacing the fuser unit, replace the engine board or SMPS.	
<b>• Replacement part</b>	

<b>• Code :</b> U1-2131	<b>• Error message :</b> Fuser Unit Failure #U1-2131 : Turn off then on.
<b>• Symptom / Cause :</b>  The Fuser is being diagnosed for Low Heat Error.	
<b>• Troubleshooting method :</b>  1. Turn the machine off and turn it on again.  2. Check the following : A. Check the power voltage of the fuser unit. (110V, 220V) B. Check if the Heat lamp is broken. C. Check if the AC connection of Heat lamp is disconnected or contaminated. D. Check if the thermostat is blown. E. Check if there is any jammed paper in fuser unit. F. Check if the power voltage is normal. (Is the voltage during the operation $\pm 10\%$ of the rated voltage?)  3. If the problem persists, replace the fuser unit.  4. If the problem persists after replacing the fuser unit, replace the engine board or SMPS.	
<b>• Replacement part</b>	

<b>• Code :</b> U1-2141	<b>• Error message :</b> Fuser Unit Failure #U1-2141 : Turn off then on.
<b>• Symptom / Cause :</b>  The Fuser is being diagnosed for Over Heat Error.	
<b>• Troubleshooting method :</b>  1. Turn the machine off and turn it on again.  2. Check the following : A. Check the power voltage of the fuser unit. (110V, 220V) B. Check if there is any jammed paper in fuser unit. C. Check if the power voltage is normal. (Is the voltage during the operation $\pm 10\%$ of the rated voltage?)  3. If the problem persists, replace the fuser unit.  4. If the problem persists after replacing the fuser unit, replace the engine board or SMPS.	
<b>• Replacement part</b>	

<ul style="list-style-type: none"> <li>● <b>Code :</b> U2-5111</li> </ul>	<ul style="list-style-type: none"> <li>● <b>Error message :</b> Black LSU Unit Failure #U2-5111 : Turn off then on.</li> </ul>
<ul style="list-style-type: none"> <li>● <b>Symptom / Cause :</b>  Black LSU occurs Lready Error.</li> </ul>	
<ul style="list-style-type: none"> <li>● <b>Troubleshooting method :</b>   <ol style="list-style-type: none"> <li>1. Turn the machine on and turn it off again. Has the error message disappeared?</li> <li>2. If the problem persists, replace the LSU unit.</li> </ol> <p><b>Caution</b> Never remove the LD PBA with Power on.</p> </li> </ul>	
<ul style="list-style-type: none"> <li>● <b>Replacement part</b></li> </ul>	

<ul style="list-style-type: none"><li>● <b>Code :</b> U2-5113</li></ul>	<ul style="list-style-type: none"><li>● <b>Error message :</b> Black LSU Unit Failure #U2-5113 : Turn off then on.</li></ul>
<ul style="list-style-type: none"><li>● <b>Symptom / Cause :</b>  - Black LSU occurs Hsync Error. 1. LD is broken. 2. LD harness is not connected correctly.</li></ul>	
<ul style="list-style-type: none"><li>● <b>Troubleshooting method :</b>  1. Turn the machine on and turn it off again. Has the error message disappeared?  2. If the problem persists, replace the LSU unit.  <b>Caution</b> Never remove the LSU cover.</li></ul>	
<ul style="list-style-type: none"><li>● <b>Replacement part</b></li></ul>	

## 4.2.3 Printing quality problems

### 1) Vertical Black Line and Band

Description : 1. Straight thin black vertical line occurs in the printing.  
2. Dark black vertical band occur in the printing.

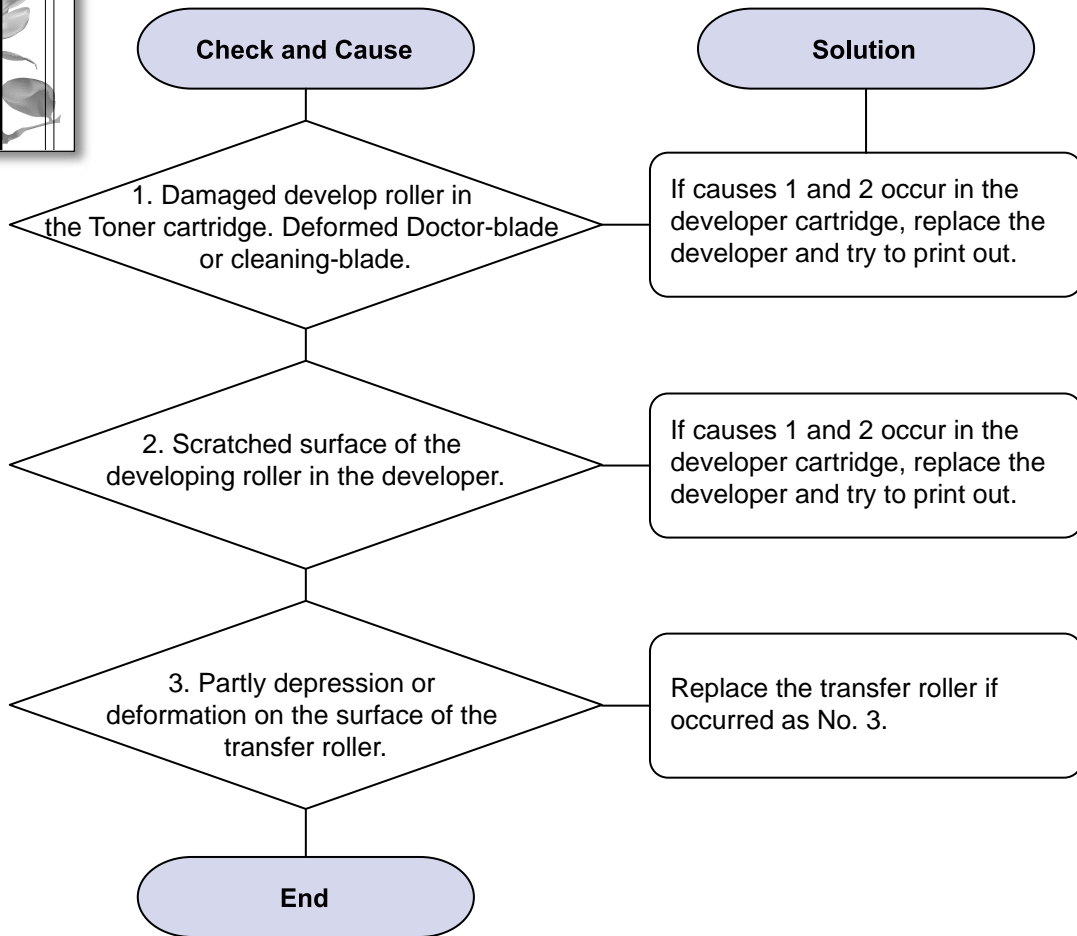
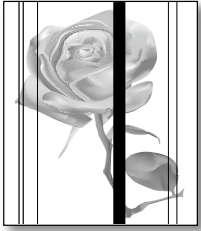



## 2) Vertical White Line

Description : White vertical voids in the image.

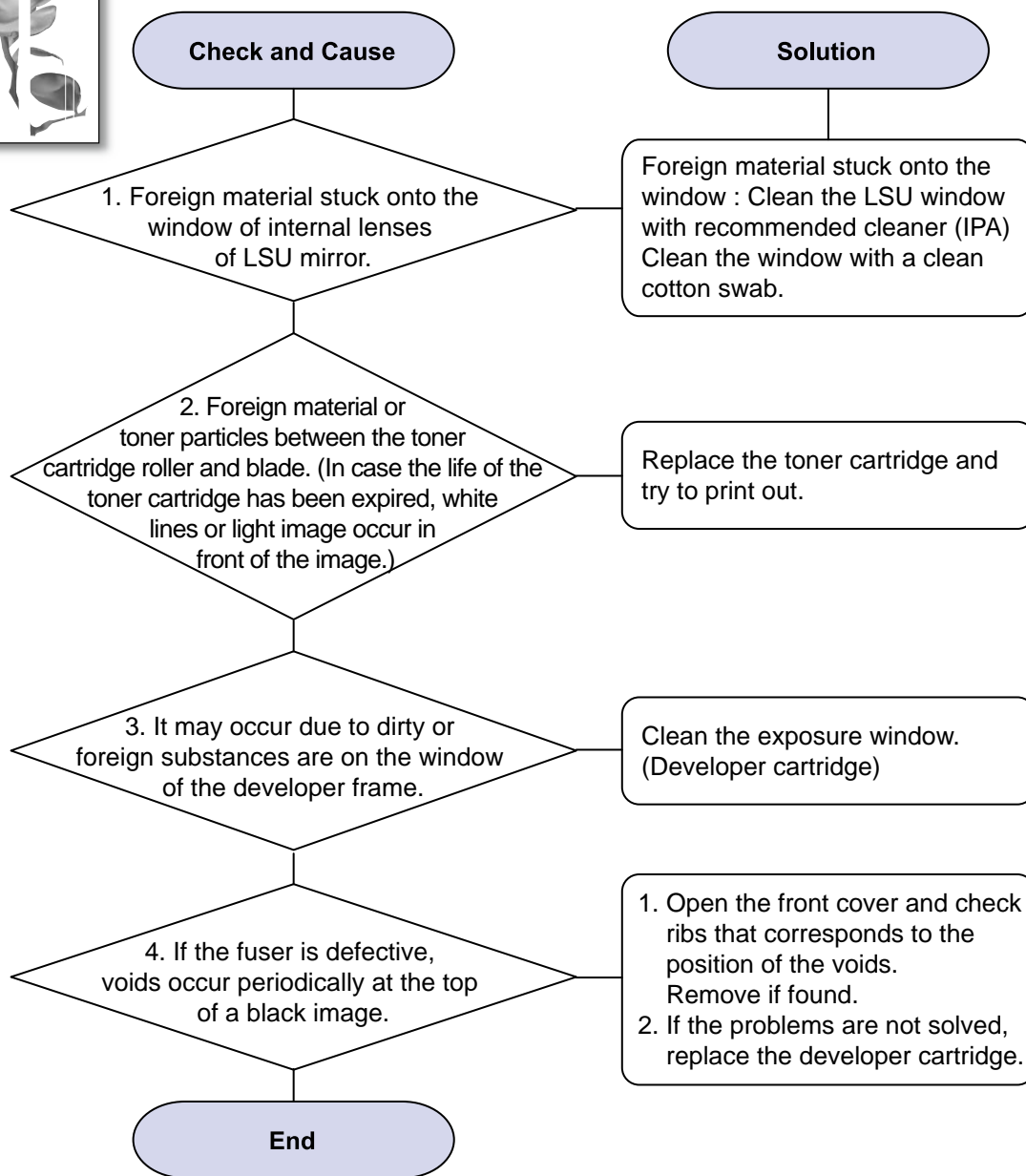
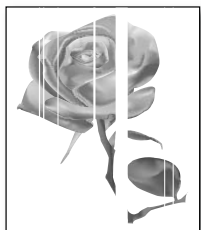

### 3) Horizontal Black Band

Description : Dark or blurry horizontal stripes occur in the printing periodically.  
(They may not occur periodically.)

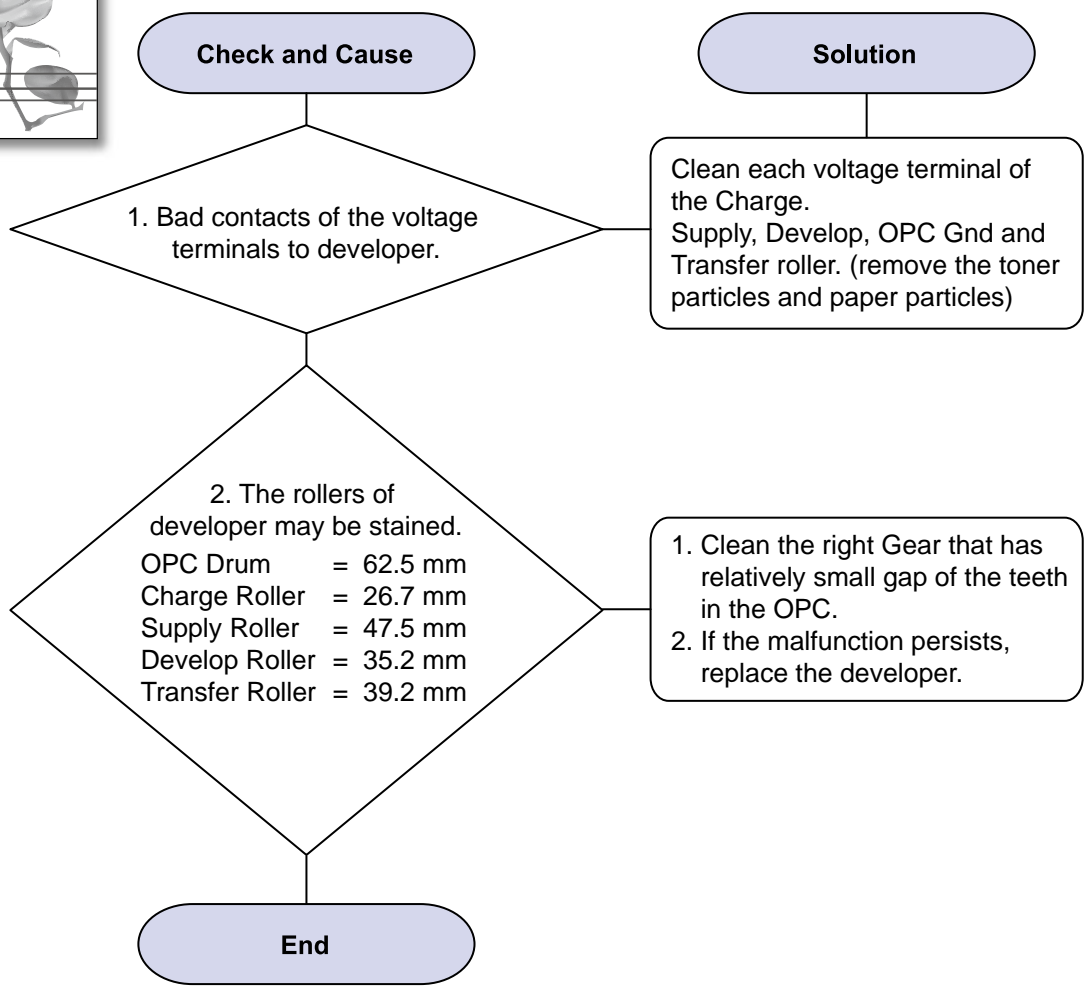
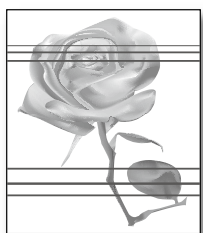

#### 4) Black and White Spot

Description : 1. Dark or blurry black spots occur periodically in the printing.  
2. White spots occur periodically in the printing.

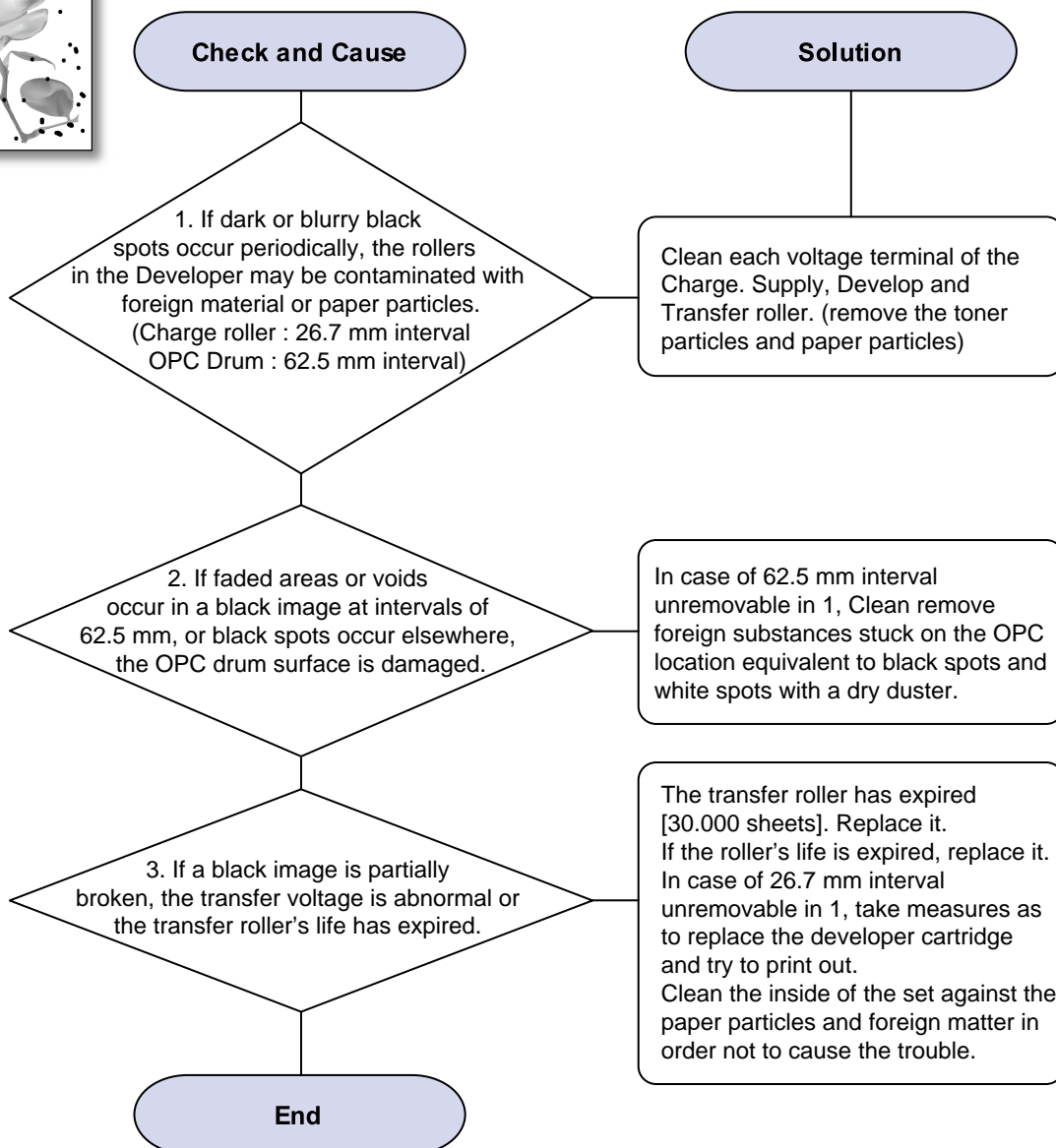
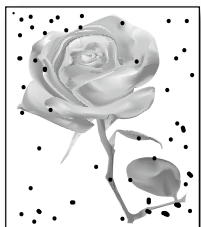

### 5) Light Image

Description : The printed image is light, with no ghost.

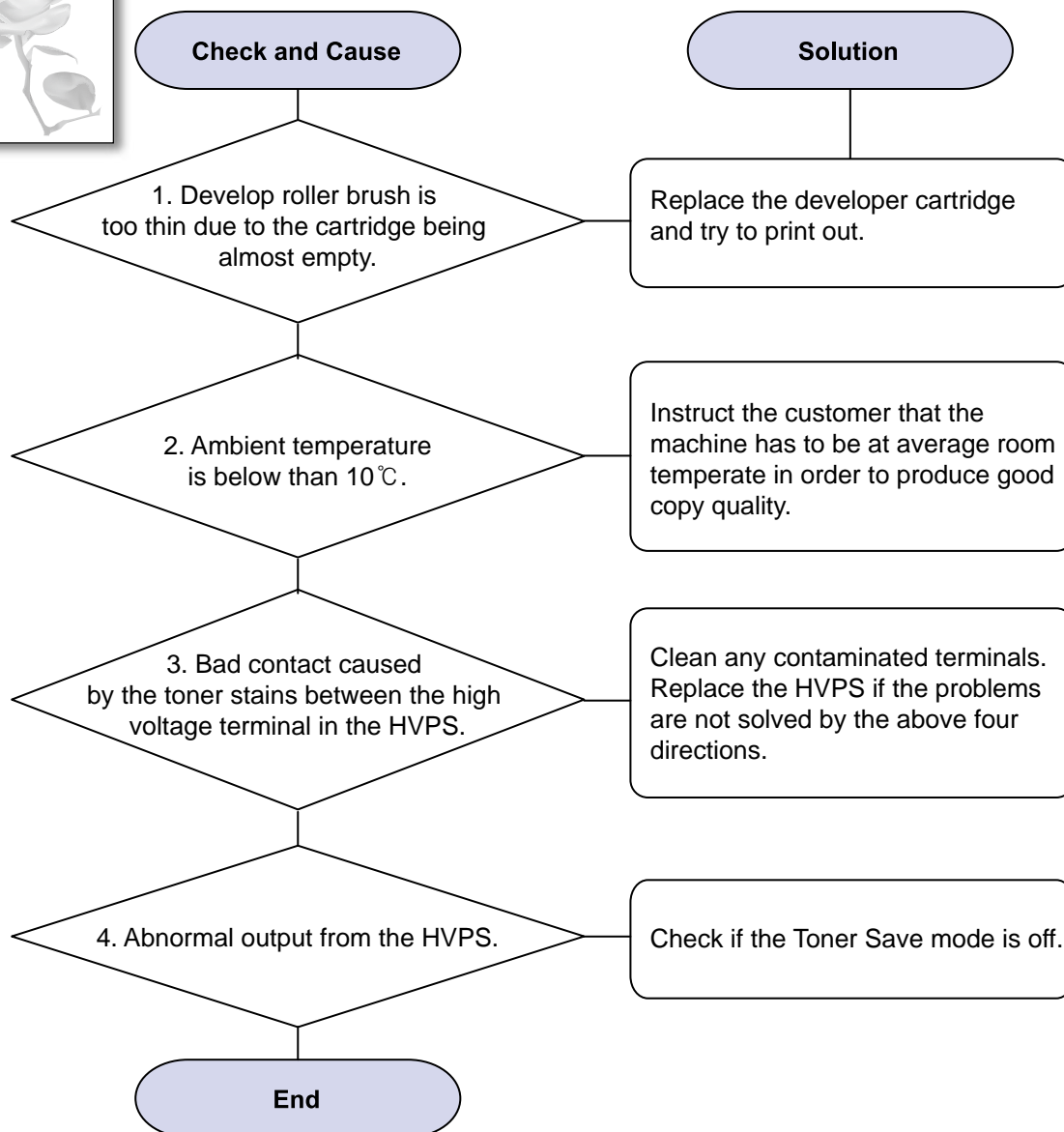
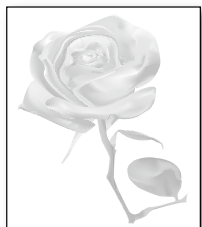

### 6) Dark Image or a Black Page

Description : The printed image is dark.

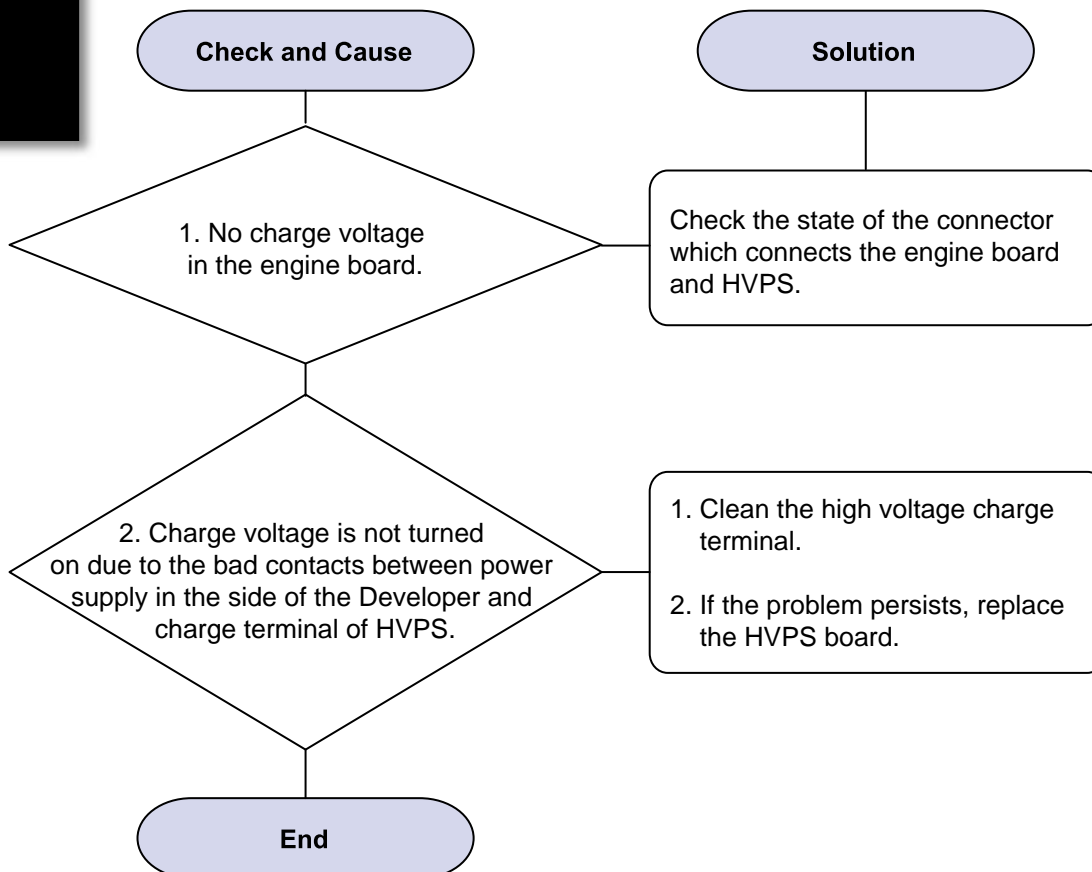

## 7) Uneven Density

Description : Print Density is uneven between left and right.

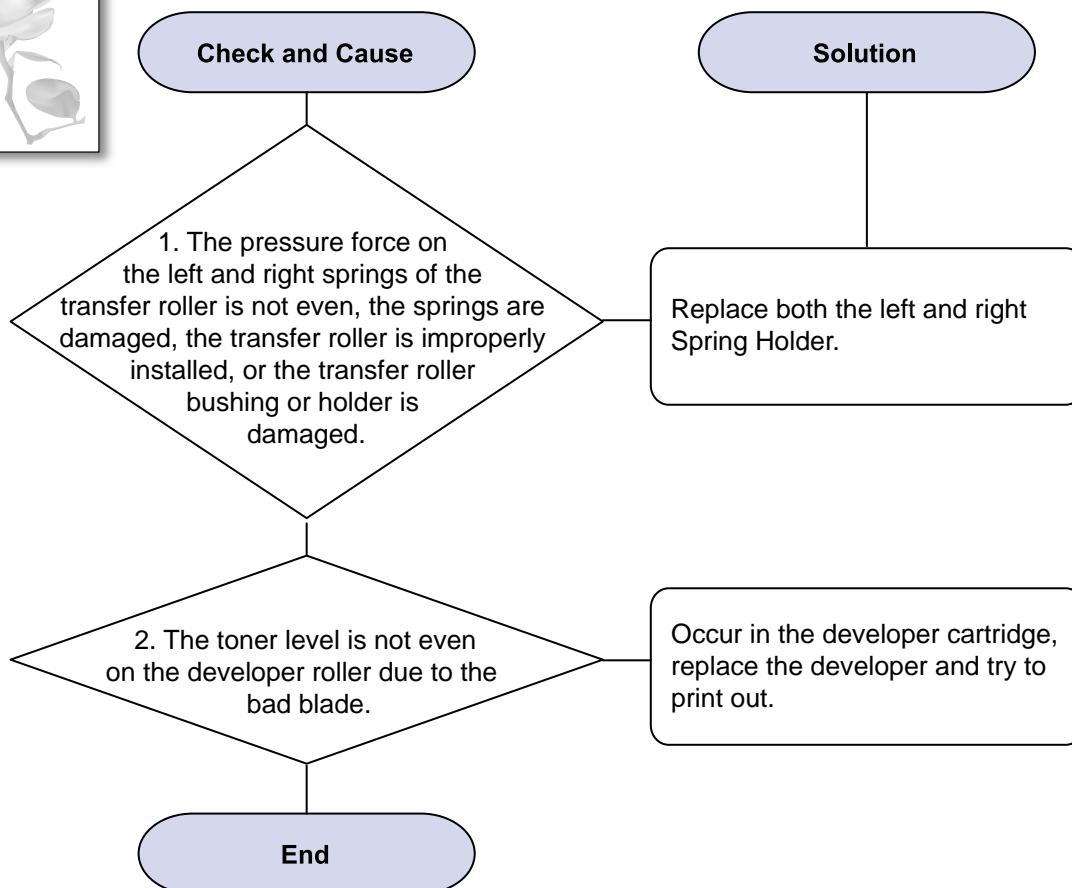

### 8) Background

Description : Light dark background appears in whole area of the printing.

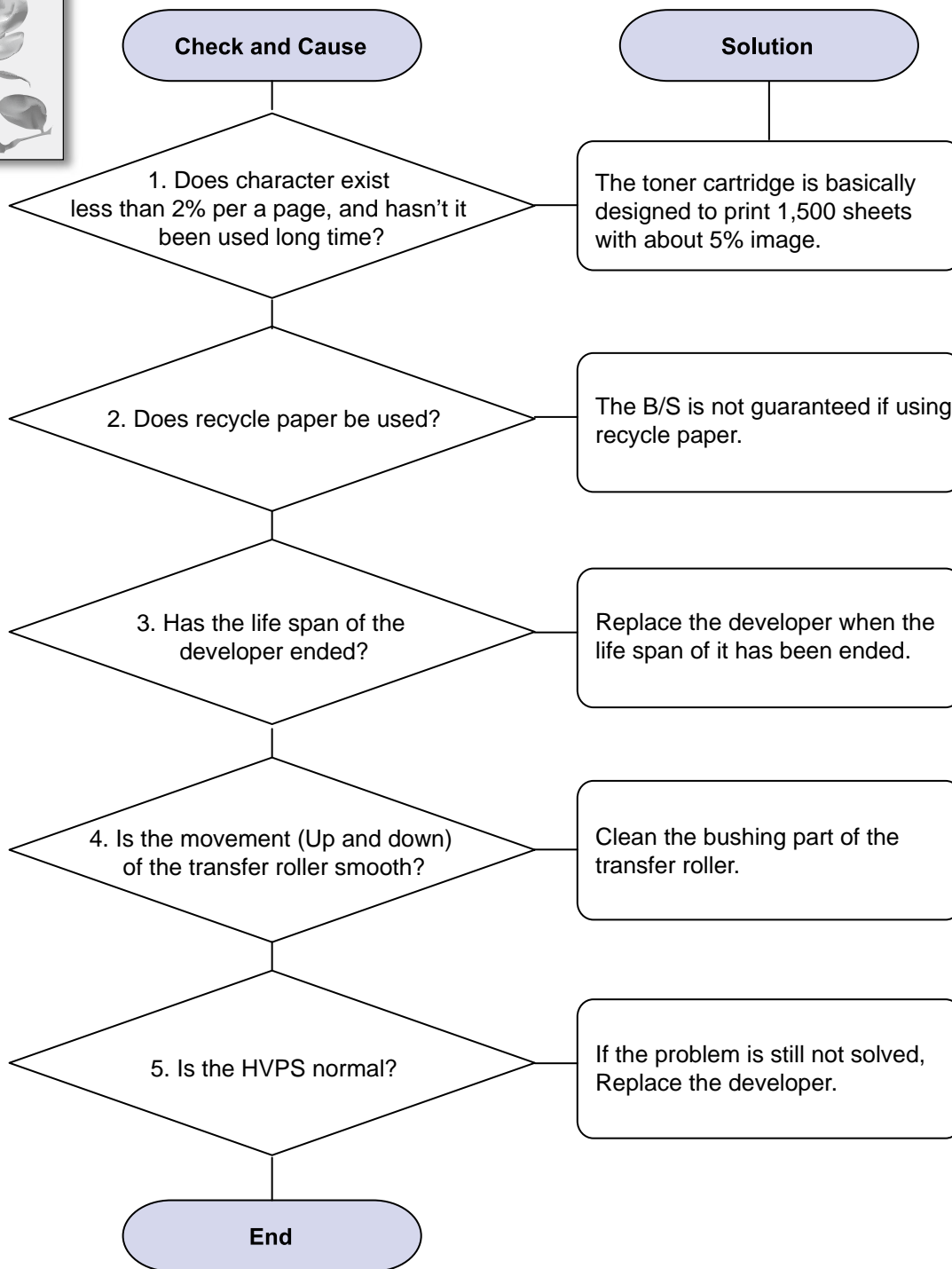

9) Ghost (1)

Description : Ghost occurs at 62.5 mm intervals of the OPC drum in the whole printing.

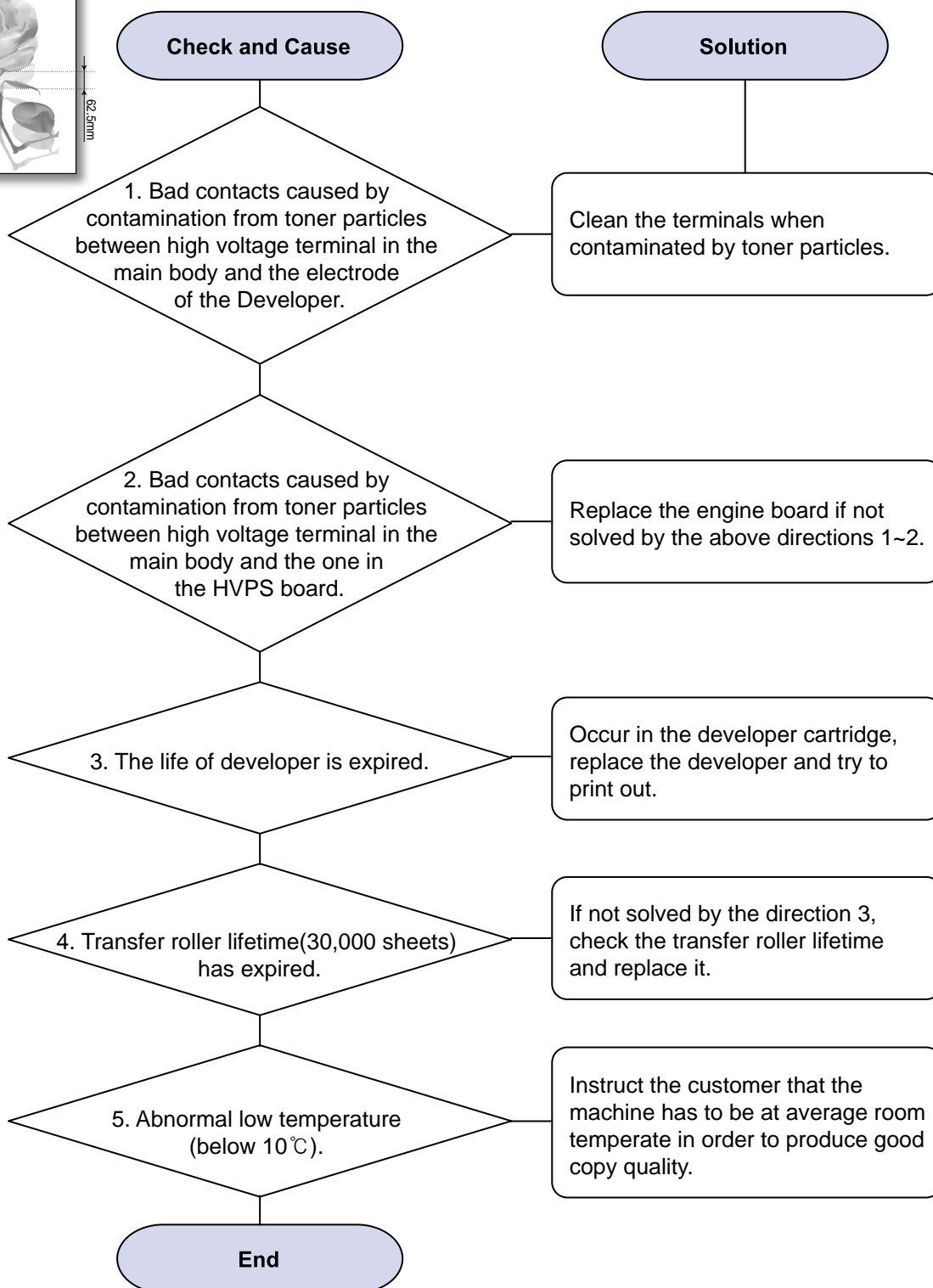
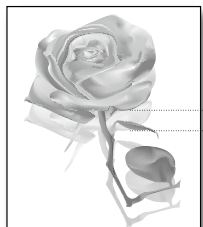



### 10) Ghost (2)

Description : Ghost occurs at 62.5 mm intervals of the OPC drum in the whole printing.  
(When Printing on card stock or transparencies using manual feeder)

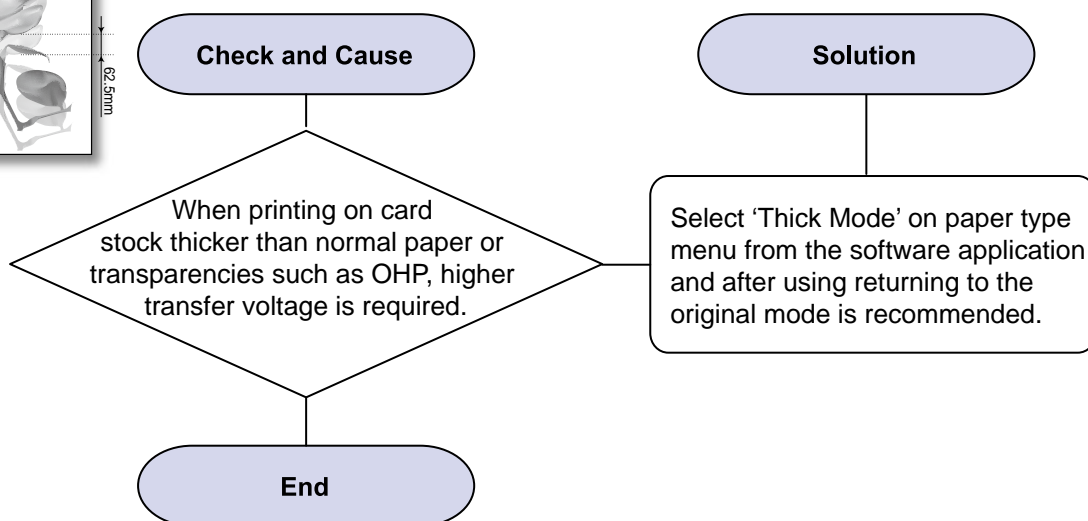
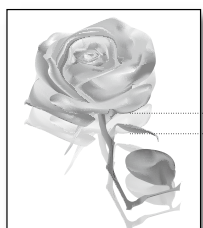

## 11) Stains on the Face of Page

Description : The background on the face of the printed page is stained.

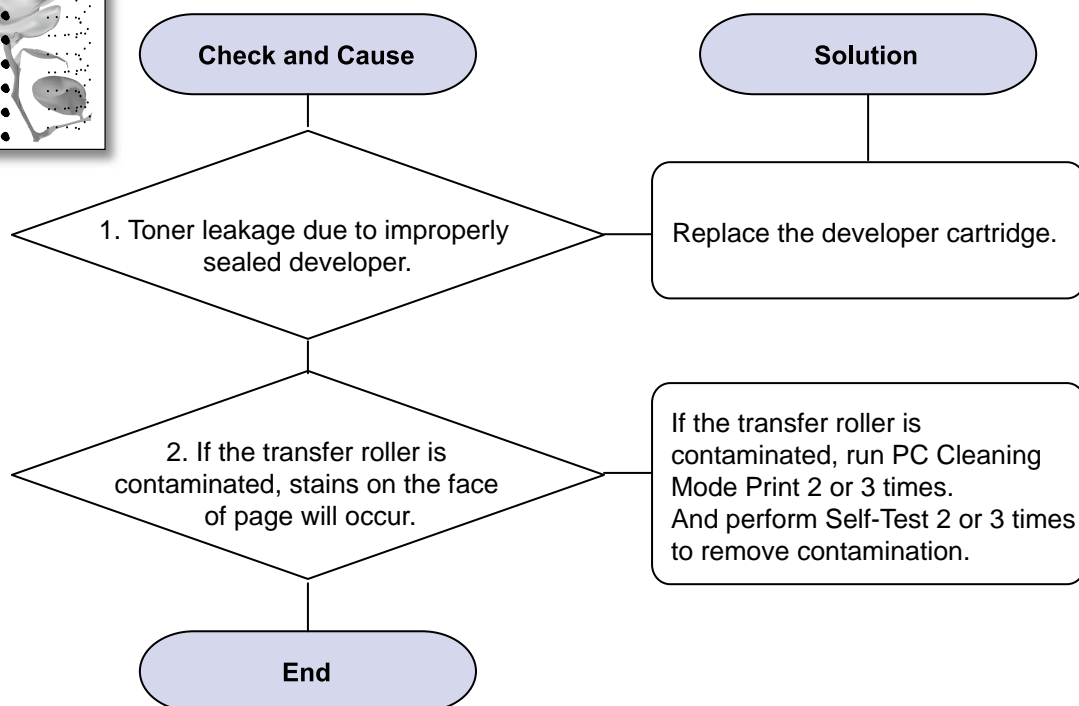
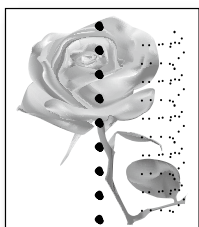

## 12) Stains on Back of Page

Description : The back of the page is stained at 39.5 mm intervals.

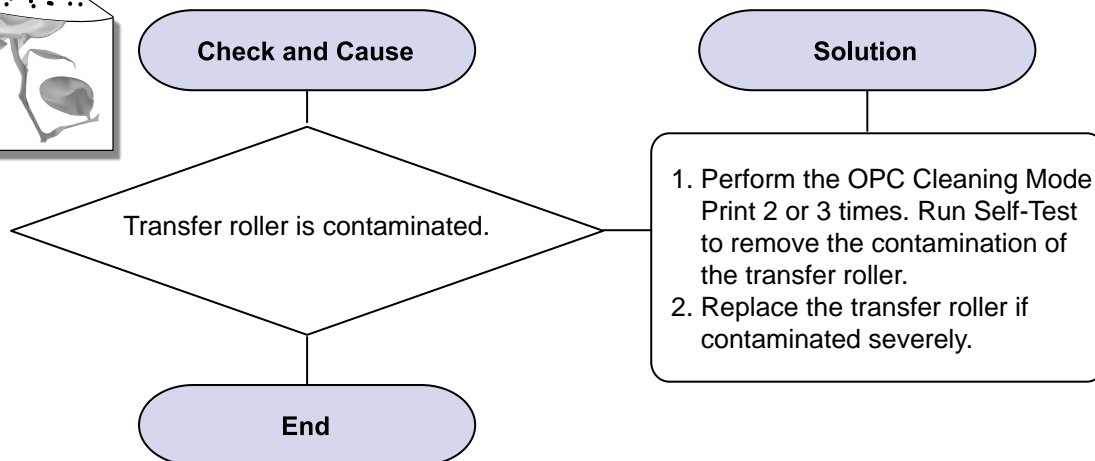
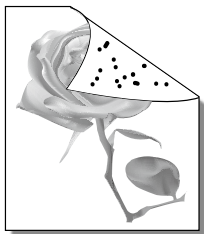

### 13) Blank Page Print out (1)

Description : Blank page is printed.

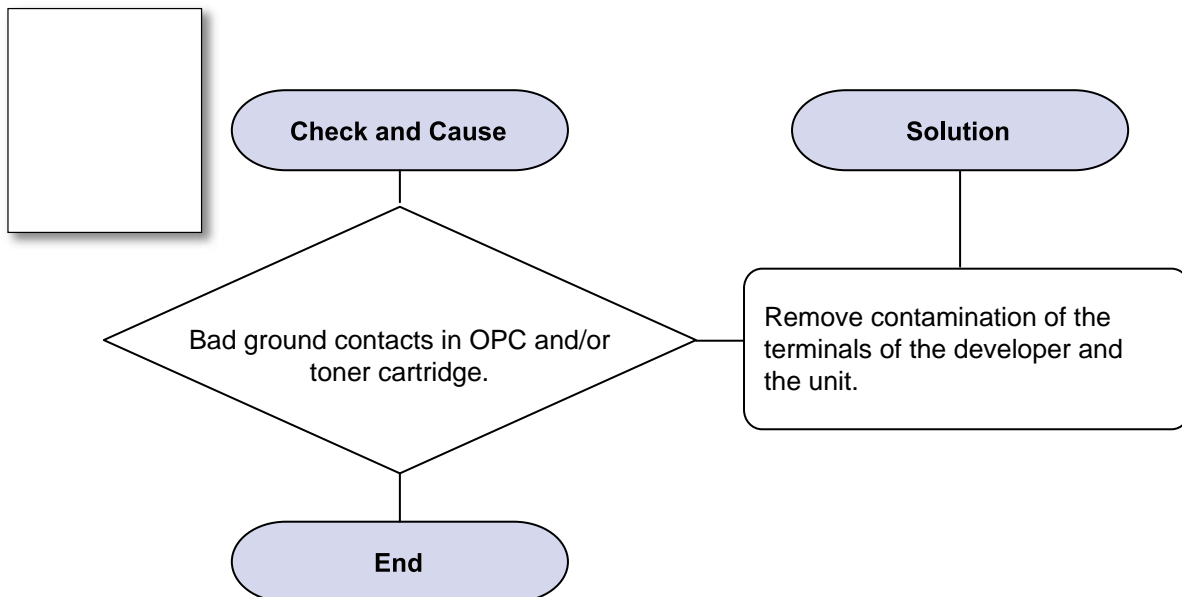

### 14) Blank Page Print out (2)

Description : 1. Blank page is printed.  
 2. One or several blank pages are printed.  
 3. When the printer turns on, several blank pages print.

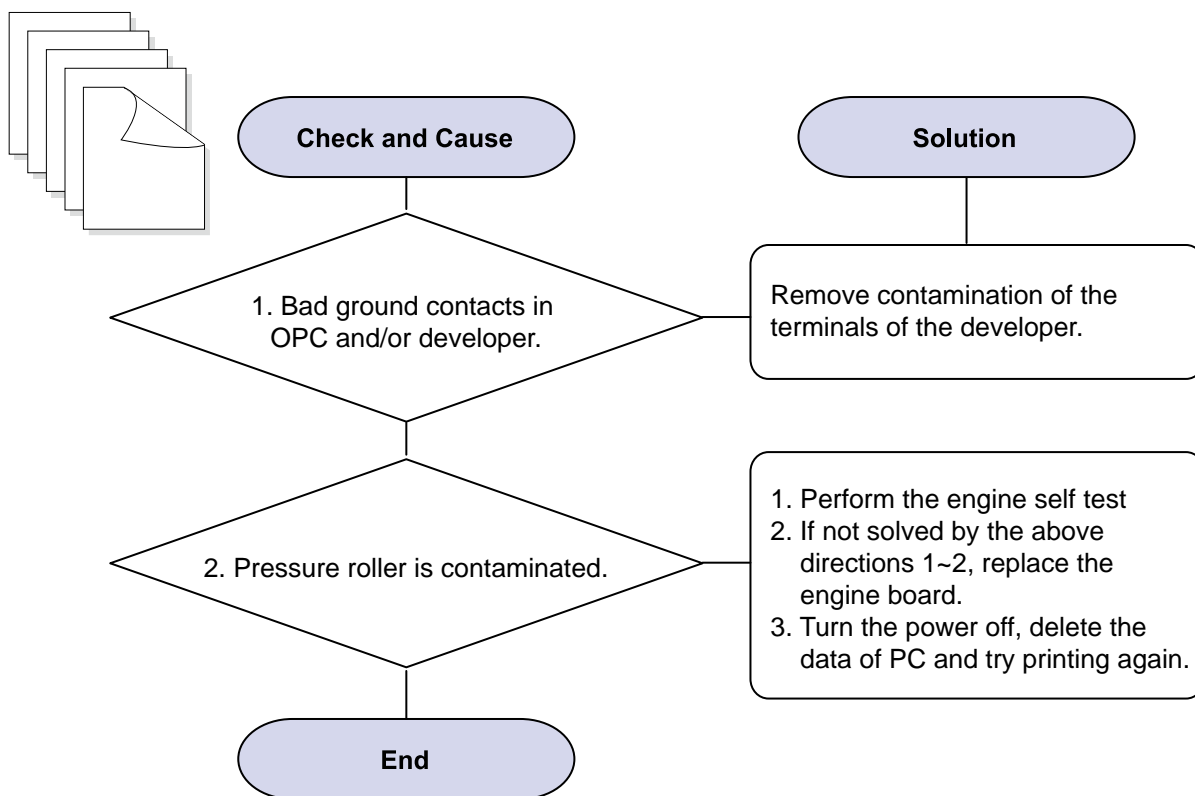

## 4.2.4 Copy Problems

### 1) Black Copy

Description : Black page is printed out when copy.

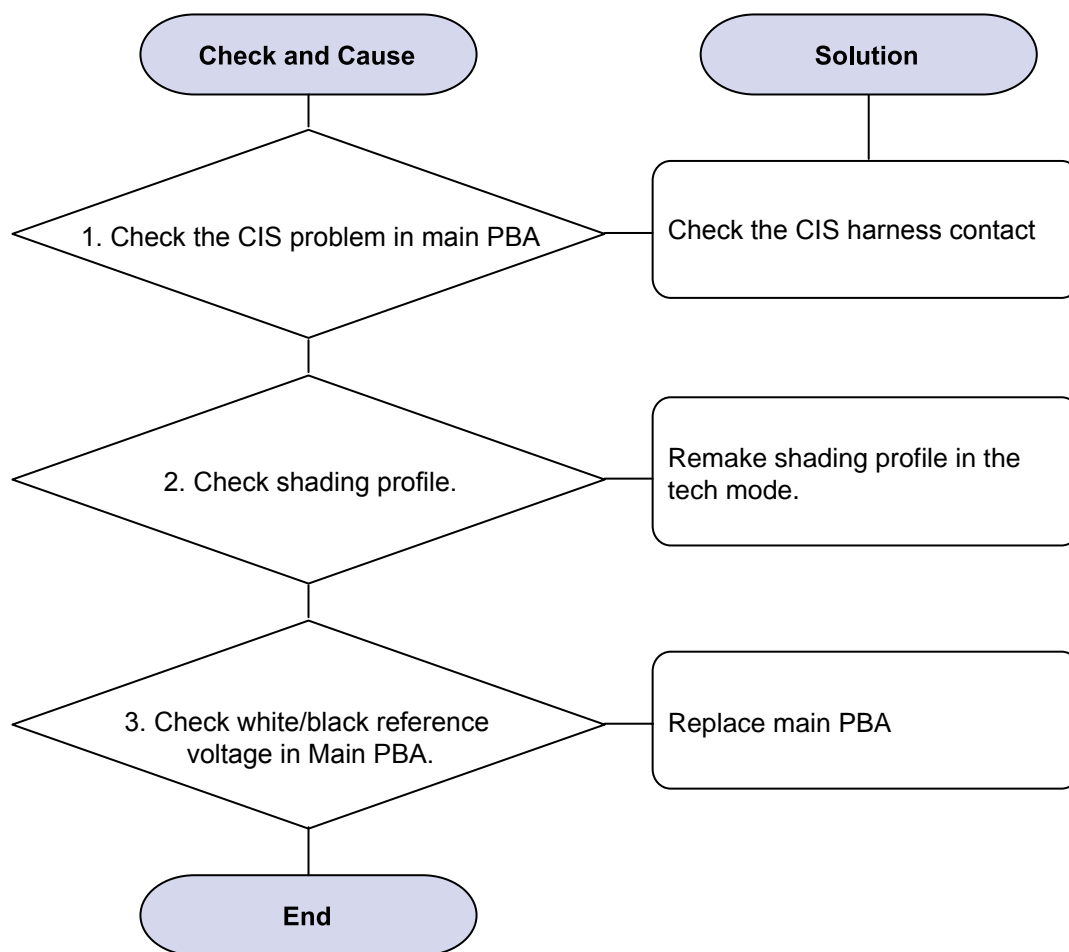

## 2) White Copy

Description : White page is printed out when Copy.

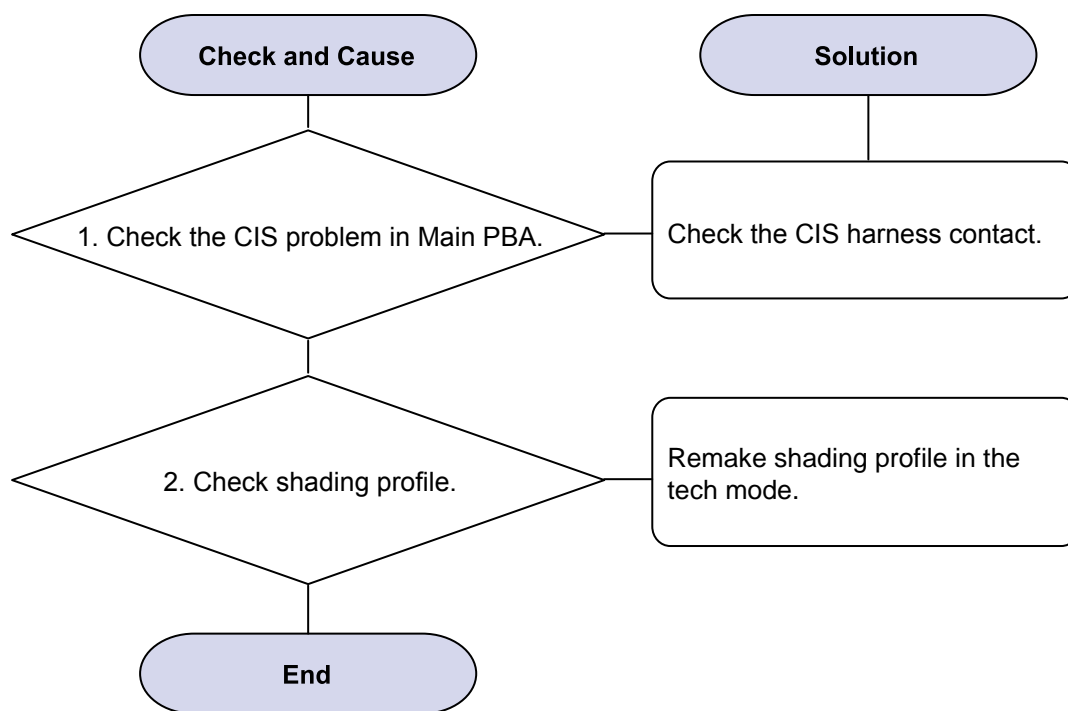

### 3) Abnormal noise

Description : There is noise when copy.

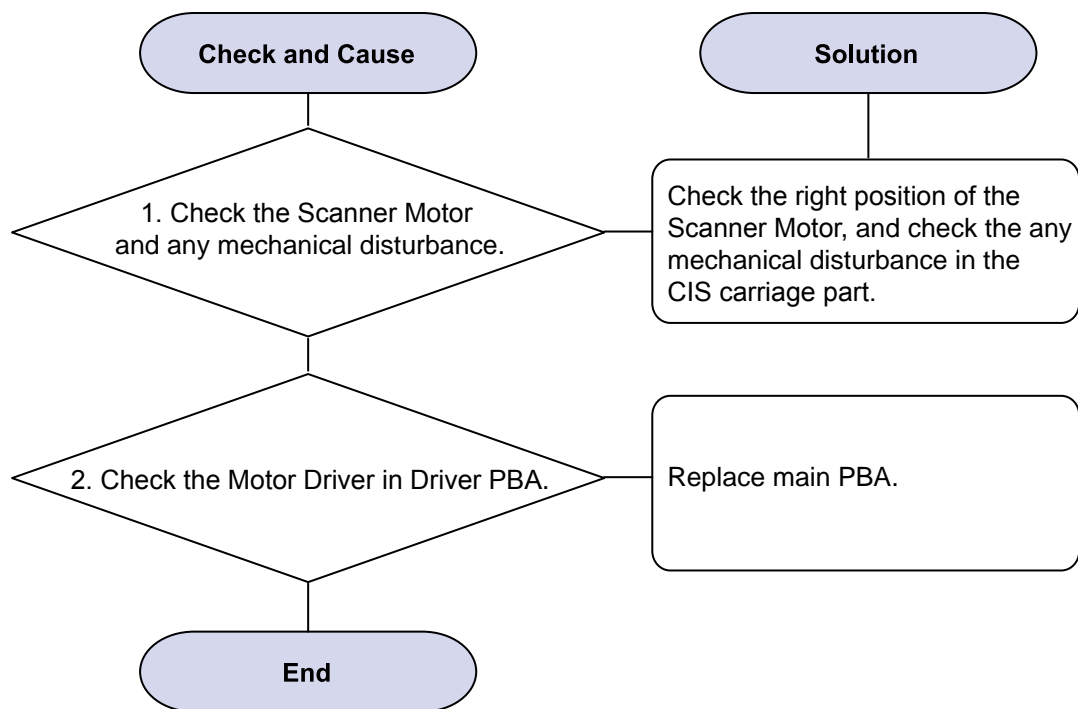



#### 4) Defective Image Quality

Description : The copied image is light or bad.

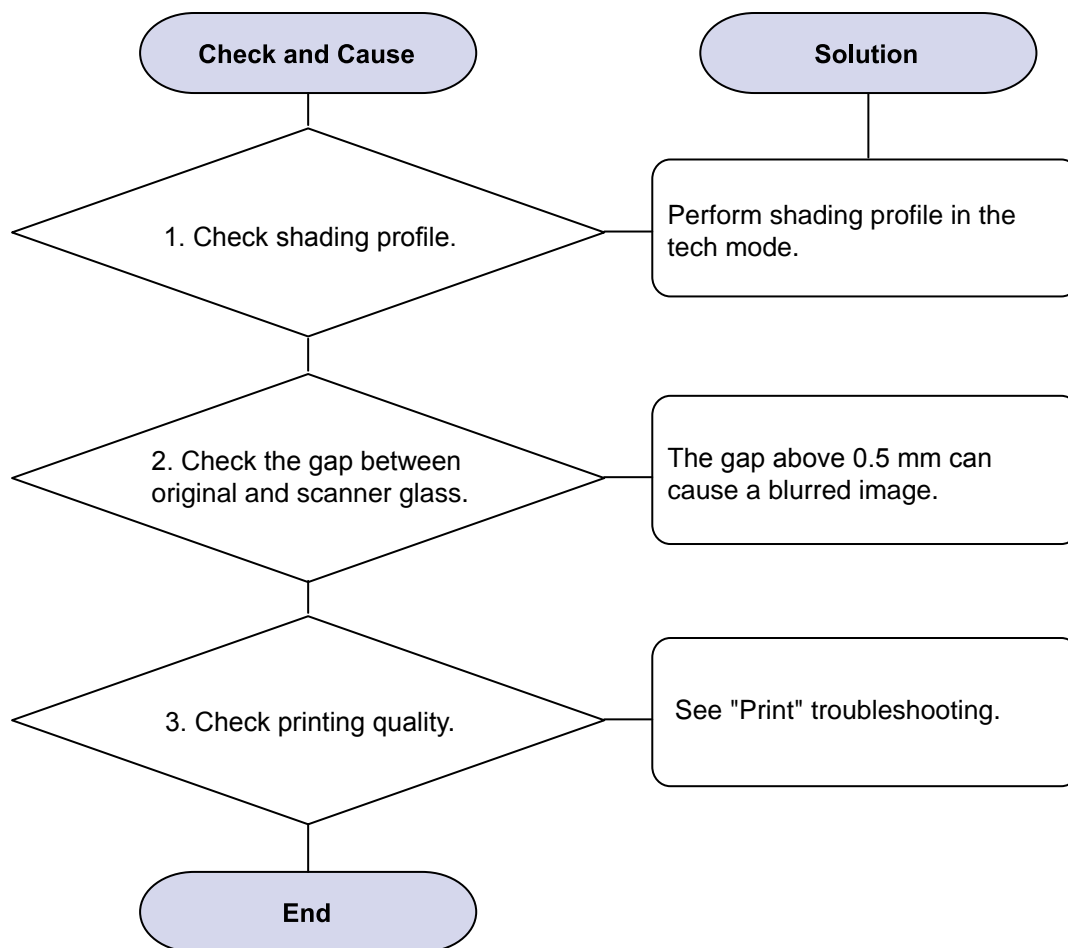

## 4.2.5 Scan problems

### 1) Defective PC Scan

Description : The PC Scan is not functioning at all.

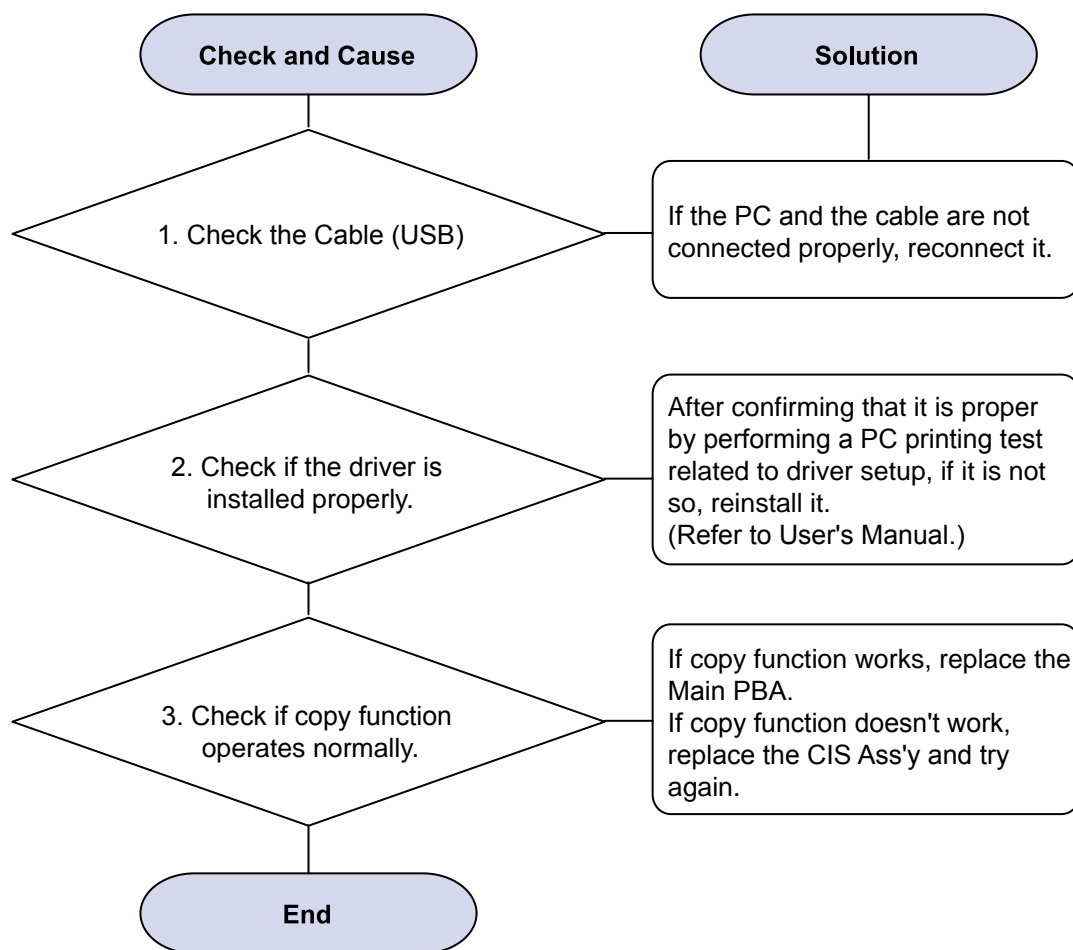

## 2) Defective Image Quality of PC Scan

Description : The image PC scanned is not clear or bad.

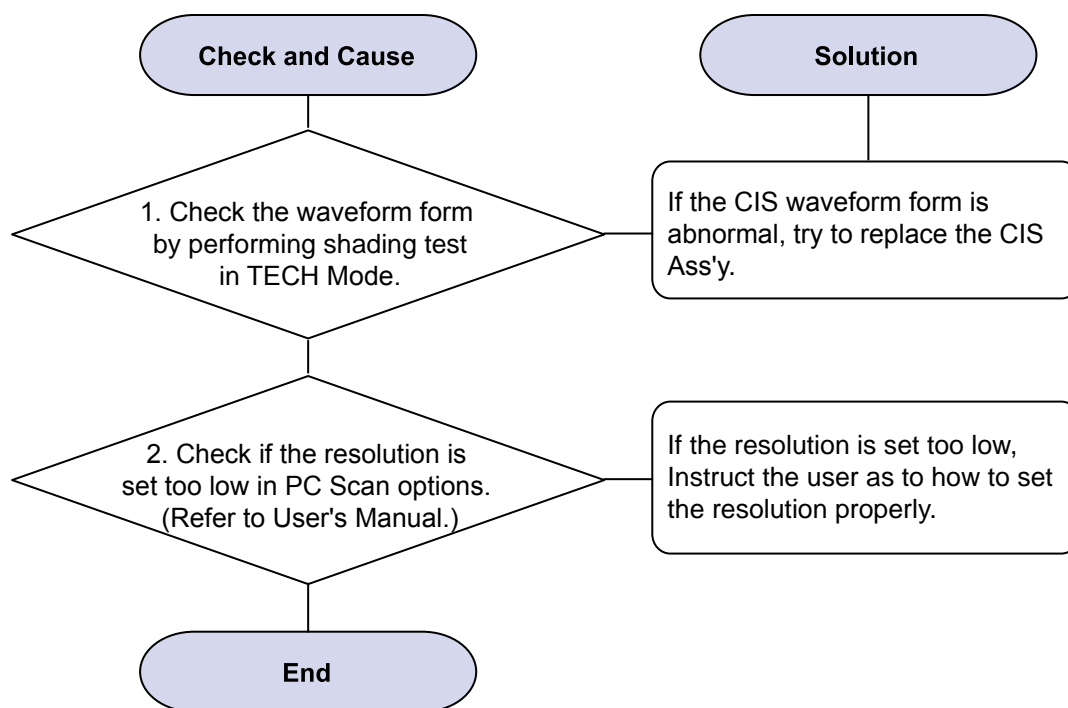

## 4.2.6 Other errors

### 1) Multi-Feeding

Description : Multiple sheets of paper are fed at once.

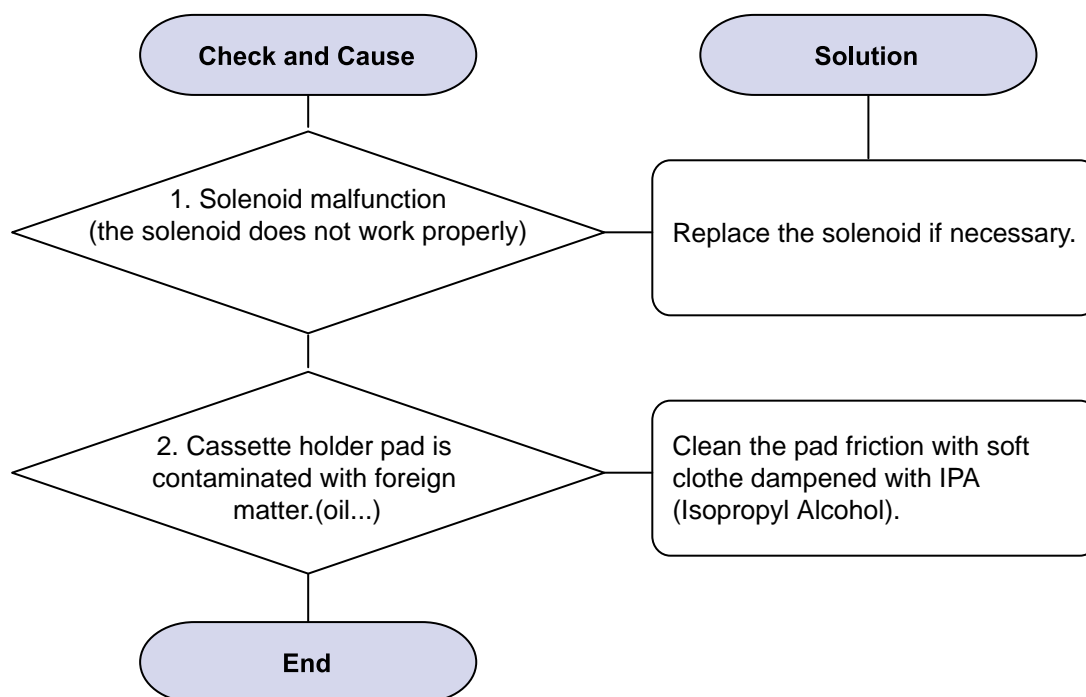

## 2) Paper Empty

Description : The paper lamp on the operator panel is on even when paper is loaded in the cassette.

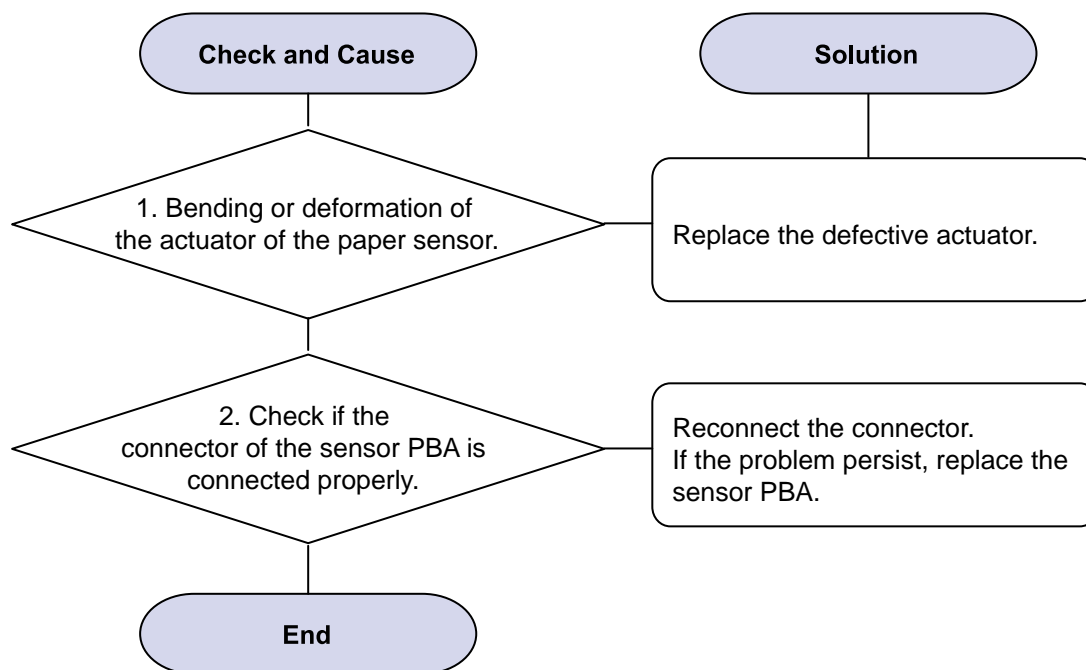

### 3) No Power

Description : When system power is turned on, all lamps on the operator panel do not come on.

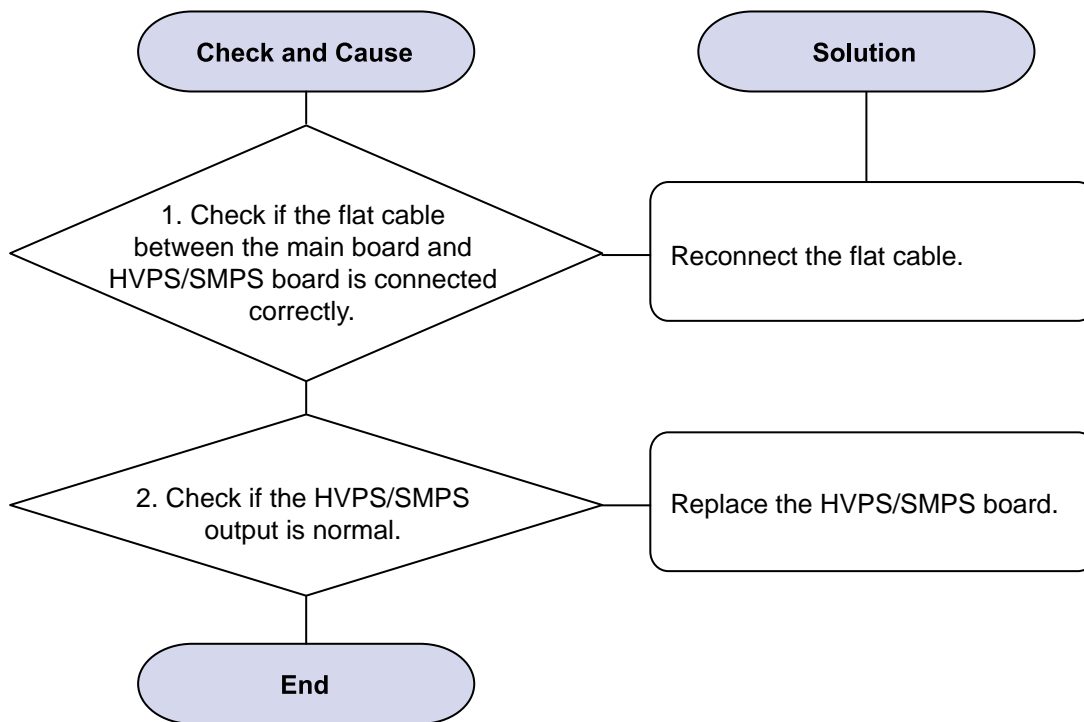

# 5. System Diagram

## 5.1 Block Diagram

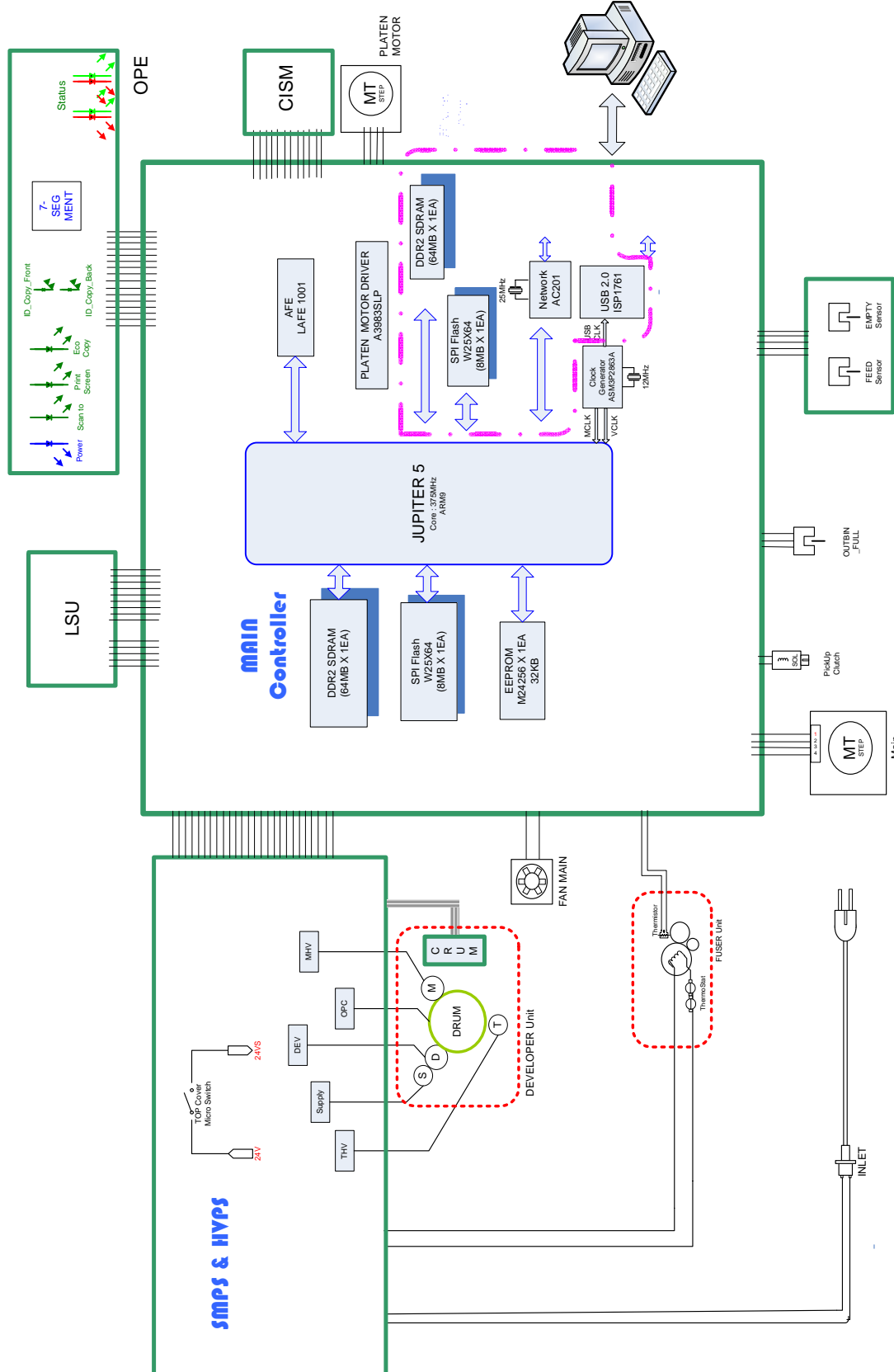

## 5.2 Connection Diagram

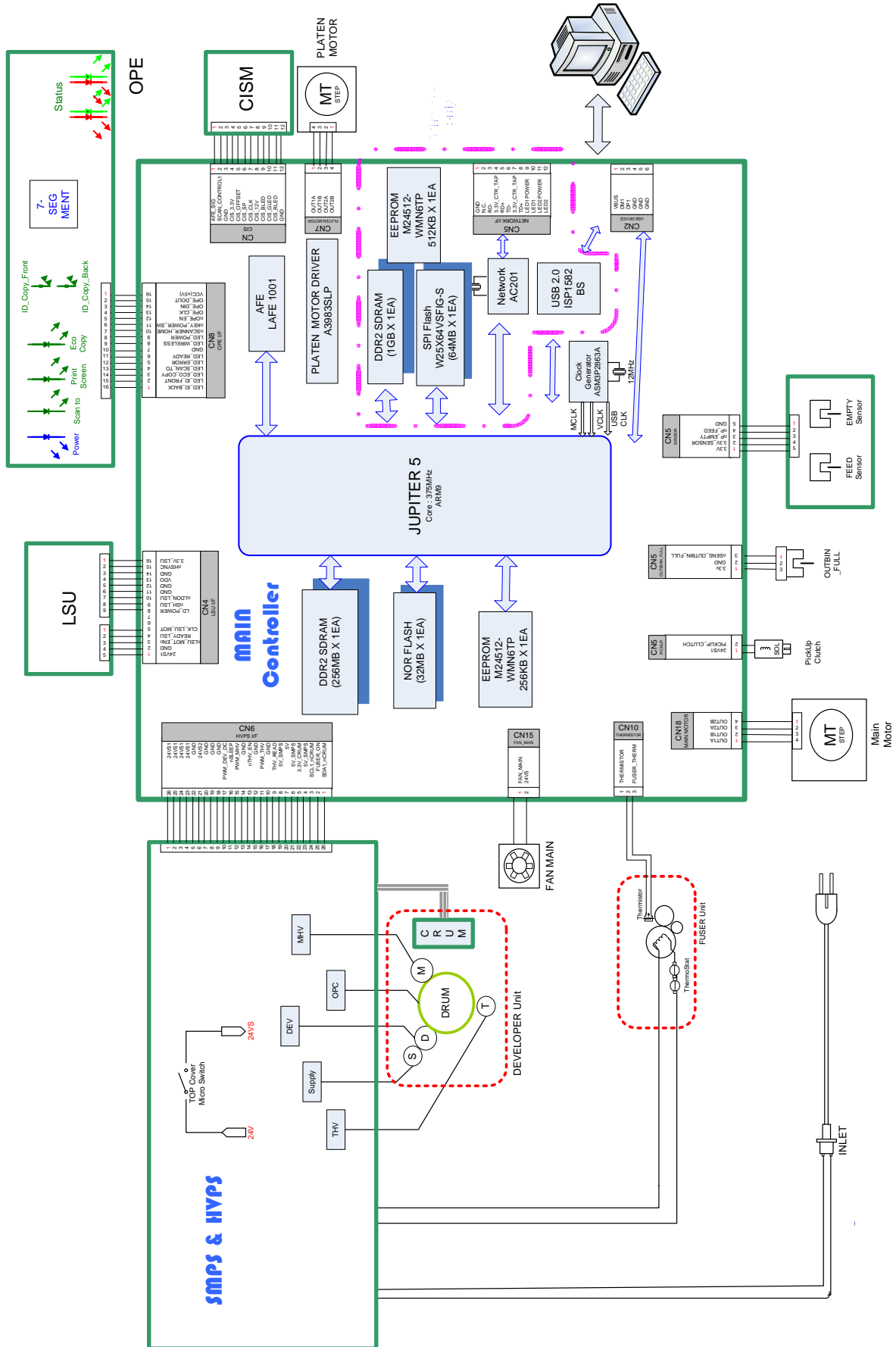



## 6. Reference Information

This chapter contains the tools list, list of abbreviations used in this manual, and a guide to the location space required when installing the printer. A definition of test pages and Wireless Network information definition is also included.

### 6.1 Tool for Troubleshooting

The following tools are recommended safe and easy troubleshooting as described in this service manual.

- **DVM (Digital Volt Meter)**

Standard : Indicates more than 3 digits.

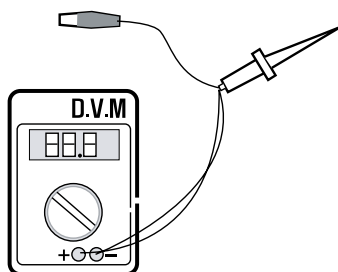

- **Driver**

Standard : “-” type, “+” type (M3 long, M3 short, M2 long, M2 short).

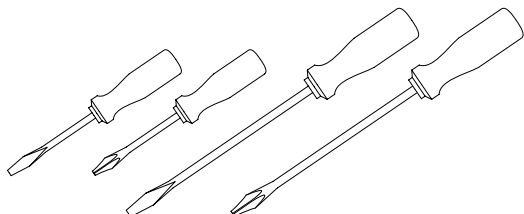

- **Tweezers**

Standard : For general home use, small type.



- **Cotton Swab**

Standard : For general home use, for medical service.



- **Cleaning Equipments**

Standard : An IPA (Isopropyl Alcohol) dry wipe tissue or a gentle neutral detergent and lint-free cloth.

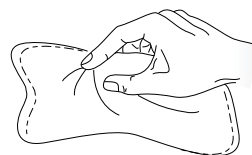

- **Vacuum Cleaner**

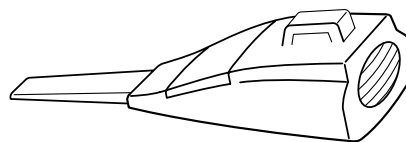

- **Spring Hook**

Standard : For general use



- **Software (Driver) installation CD ROM**

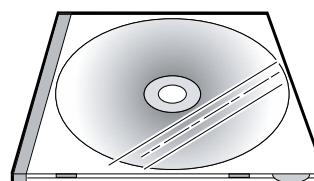

## 6.2 Acronyms and Abbreviations

The table below explains abbreviations used in this service manual.  
The contents of this service manual are declared with abbreviations in many parts. Please refer to the table.

### 6.2.1 Acronyms

ABS	Automatic Background Suppression(a kind of copy feature)	FDI	Foreign Device Interface
APF	Automatic Paper Feeder(Tray)	FIA	Foreign Interface Attachment
BOOTP	BOOTSTRAP PROTOCOL	FRU	Field Replaceable Unit
CCD	Charged Coupled Device	FPOT	First Print Out Time
CIS	Contact Image Sensor	GW	GateWay
CPM	Copies Per Minute	HH	High Temperature, High Humidity (Testing Chamber conditions)
CP	Control Panel(= OPE)	HPVC	Halftone Printing Video Controller in the SPGPm (Graphic Processor for Copy)
CQ	Copy Quality	IDC	International Data Corp.
CRU	Customer Replaceable Unit	IMAP	Internet Message Access Protocol
CRUM	CRU Memory	IPP	Internet Printing Protocols
CW	Center Ware	IPM	Images Per Minutes
CWDP	Center Ware Device Discovery Software(Samsung equivalent of Samsung's SyncThru)	IPX	Internetwork Packet Exchange
CWIS	Center Ware Internet Services	IQ	Image Quality
DADF	Duplex Auto Document Feeder (= DADH)	ITU	International Telecommunication Union
DC	Direct Connect	JBIG	Joint Binary Image Group (a kind of image data coding method)
DDNS	Dynamic Domain Name System	JPEG	Joint Photographic Expert Group (a kind of image data coding method)
DHCP	Dynamic Host Configuration Protocol	LCD	Liquid Crystal Display
DLC	Data Link Control	LEF	Long Edge Feeding
DNS	Domain Name System	LL	Low Temperature, Low Humidity (Testing Chamber conditions)
ECM	Error Correction Mode	LPR/LPD	Line Printer Daemon Protocols (LPR is a TCP-based protocol)
ECP	Enhanced Capability Port	LSU	Laser Scanning Unit
e-Coil	Extended Coil technology for Rapid(Fast) Fusing.	LUI	Local User Interface
EH&S	Samsung Environment, Health, & Safty	MCBF	Mean Copy Between Failure
ESMTP	Extended Simple Mail Transfer Protocol	MDSP	Multiple Document Single Printout
EP	Electro Photography	MFP	Multi-Functional Product
EPC	Electric Pre-Collation	MH	Modified Huffman (a kind of image data coding method)
FCOT	First Copy Out Time		

MIB	Management Information Base	RT-OS	Real Time Operating System
MIME	Multipurpose Internet Mail Extensions	RX	Receive
MR	Modified Read (a kind of image data coding method)	S2E	Scan-To-Email
MMR	Modified and Modified Read (a kind of image data coding method)	SAD	Solid Area Density
MN std	Multi-National Standard	SC	Service Call
MSOK	Master SOK(System Operation Key)	SCF	Second Cassette Feeder
MSO	Mixed Size Original	SDSP	Single Document Single Printout
MP	Multi Purpose	SDMP	Single Document Multiple Printout
MPBF	Mean Print Between Failure	SDR	Shut Down Rate
MSI	Multi Sheet Input	SEF	Short Edge Feeding
MTBF	Mean Time Between Failure	SIR	Sacrificed(or Standard) Image Reference
MTTR	Mean Time To Repair	SOK	System Operation Key
NCP	Network Control Protocol	sRGB	Standard RGB (Color Coordinate System)
NIC	Network Interface Card	SNMP	Simple Network Management Protocol
NOS	Network Operating System	TCP/IP	Transmission Control Protocol/Internet Protocol
NN	Normal Temperature, Normal Humidity (Testing Chamber conditions)	TBC(or tbc)	To Be Confirmed
NSDR	Non-Shut Down Rate(=USDR)	TBD(or tbd)	To Be Determined
NW	Network	TIFF	(Adobe & Aldus) Tagged Image File Format
OD	Optical Density	TRIM	Technical Retrofit Interim Maintenance
OHD	On Hook Dial	TTM	Time to Market
OSOK	Optional SOK(System Operation Key)	TX	Transmit
OP	Operational Procedure	UI	User Interface
PCL	Printer Control Language	UMC	Unit Manufacturing Cost
PDF	(Adobe) Portable Document Format	UMR	Unscheduled Maintenance Ratio
PPM	Pages Per Minutes	UPnP	Universal Plug and Play
PQ	Print Quality	USB	Universal Serial Bus
PS/3	PostScript Level-3	USDR	Un-Shut Down Rate(=NSDR)
PVC	Printing Video Controller in the SPGPm(Graphic Processor for Printer)	XCMI	Samsung's Management Information Base
QCD	Quality, Cost, and Delivery	WA	Warranty Action
RCP	Remote Control Panel	W x D x H	Width x Depth x Height

## 6.2.2 Service Parts

ACRONYM	EXPLANATION
ELA HOU-SCANNER ASS'Y	ELA=Electrical Assembly, HOU =Housing
MEA UNIT-COVER PA EXIT ASS'Y	MEA= Mechanical Assembly, PA=Paper
PMO-TRAY EXTENTION MP NE	PMO= Processing Mold MP=Multi-Purpose(Bypass) tray NE=for NEC (common as Samsung Halk printer)
MEC-CASSETTE ASS'Y(LETTER)	MEC = Mechanic Combined unit
COVER-M-FRONT	M=Mold
MPR-NAME/PLATE	MPR= Machinery Press,
UNIT-LSU	LSU =Laser Scanning Unit
SMPS-SMPS(V1)+HVPS	SMPS =Switching Mode Power Supply HVPS =High Voltage Power Supply
ELA-OPC UNIT SET	OPC=Organic Photo-Conductive
ELA HOU-MP ASS'Y	MP =Multi-Purpose (Bypass) tray
PBA MAIN-MAIN	PBA =Printed circuit Board Assembly
PMO-CONNECT PAPER MFP	MFP =Multi-Functional Peripheral
FAN-DC	DC =Direct Current
CBF POWER STITCH GRAY	CBF= Cable Form
MEA UNIT GUIDE CST PA ASS'Y	CST=Cassette(Paper tray), PA=Paper
PBA LIU	PBA =Printed circuit Board Assembly LIU =Line Interface Unit for FAX
SHIELD-P_MAIN LOWER	P=Press
CBF HARNESS-LIU GND	LIU =Line Interface Unit for FAX GND= Ground
PMO-COVER FEED AY	AY=Assembly
PMO-COVER BRKT MOTER	BRKT=Bracket
CBF HARNESS-LSU	LSU =Laser Scanning Unit
IPR-SHIELD SMPS UPPERI	IPR=Iron Press
PMO-BUSHING P/U.MP	P/U=Pickup MP=Multi-Purpose (Bypass) Tray
PMO-HOLDER GEAR TRr	TR= Transfer Roller
SPRING ETC-TR_L	TR_L=Transfer Roller - Left
PMO-CAM JAM REMOVE	PMO-CAM= Processing Mold-CAM
PMO-LOCKER DEVE	DEVE=Developer

ACRONYM	EXPLANATION
SPECIAL SCREW(PANNEL MFP)	MFP =Multi-Functional Peripheral
A/S MATERAL-DUMMY UPPER ASS'Y	A/S=After-Service
MCT-GLASS ADF	MCT= Machinery Cutting ADF=Automatic Document Feeder
PPR-REGISTRATION EDGE(F)	PPR= Processing Press
IPR-HOLDER GLASSI	PR=Iron Press
MCT-GLASS SCANNER(LLEGAL)	MCT= Machinery Cutting
CBF HARNESS-OPE	OPE=Operation Panel(Control Panel)
PBA SUB-D_SUB	PBA SUB-D_SUB =>Sub Printed circuit Board Assembly for the D-SUB type electrical connector (D-Sub) a kind of the connector type(shape 'D')
COVER-M-CCD CABLE	M=Mold CCD=Charge Coupled Device
COVER-SCAN LOWER(UMAX)	UMAX=> Supplier's name for CCD module
ICT-INSERT SHAFTI	ICT= Iron Cutting
IPR-BRK SCAN BD	IPR=Iron Press BRK=Bracket BD= Board
CBF SIGNAL-CCD FFC	CCD = Charge Coupled Device FFC =Flexible Flat Cable
COVER-M-OPE	M=Mold OPE=Operation Panel(Control Panel)
KEY-M-COPY	M=Mold
PLATE-M-ALPHA KEY	M=Molde ALPHA=Alphabet
PMO-GUIDE DP SIDE	DP=Duplex
RING-CS	CS= Compress
GEAR-MP/DUP DRV	MP =Multi-Purpose (Bypass) tray DUP DRV = Duplex Driver
IPR-BRKT G DUPI	PR=Iron Press BRKT=BRACKET G= Ground UP=Duplex
PMO-BUSHING TX(B4)	TX=Transmit
PMO-TRAY CASE, MP	MP=Multi-Purpose tray(Bypass tray)

ACRONYM	EXPLANATION
SPRING CS RE	CS=Compress RE=Rear
SPRING CS FR	CS=Compress FR=Front
PMO-BUSHING FINGER, F	F=Front
ICT-SHAFT-EXIT LOWER ID	ID=Idler
SPRING-EXIT ROLL FD	FD=Face Down
PMO-BUSHING_P/U,MP	P/U=Pickup MP =Multi-Purpose (Bypass) tray
PMO-HOLDER CAM MPF	MPF=Multi-Purpose Feeder(=MP)
PMO-GEAR P/U MPF	P/U=Pickup
MFP =Multi-Functional Peripheral	
RPR-RUBBER PICK UP,MP	RPR=Rubber Press
PBA SUB-MP SEN	PBA SUB-MP-SEN =>Sub Printed circuit Board Assembly for the MP-SEN(= Multi-Purpose (Bypass) tray-Sensor)
A/S MATERIAL-PICKUP,MP	
FOOT-ML80	
HOLDER CATCH CST MC2	MC2=>McKinley2 (Samsung Project code name)
IPR-GROUND PLATE A(OPC)	OPC=Organic Photo-Conductive
ELA M/M-AUD SPEAKER	ELA M/M => Electrical Assembly M/M AUD=Audio
CBF HARNESS-OPC GND	OPC GNG=Organic Photo-Conductive-Ground
IPR-GROUND PLATE SCF	SCF=Second Cassette Feeder(Tray2)
PBA SUB-PTL	PBA SUB-PTL=>Sub Printed circuit Board Assembly for the PTL(= Pre Transfer Lamp)
PBA SUB-FEED+P.EMP SEN.	PBA SUB-FEED=>Sub Printed Circuit Board Assembly for the feeder EMP SEN=Empty Sensor
MOTOR STEP-MCK2(MAIN)	
GEAR-EXIT/U	EXIT/U=EXIT/Upper
GEAR-RDCN FEED INNER	RDCN=Reduction
CBF-HARNESS-MAIN-THV WIRE	THV =Transfer High Voltage
CBF-HARNESS-MAIN-MHV WIRE	MHV= High Voltage(Charge Voltage)

ACRONYM	EXPLANATION
GEAR-EXIT/U, ID	U=Upper ID=Idler
IPR-TERMINAL FU	FU=Fuser
PMO-BEARING H/R-F	H/R-F=Heat Roller - Front
BEARING-H/R L	H/R-L=Heat Roller -Left
PEX-ROLLER EXIT F_UP	PEX= Processing Extrude F_UP=Face Up
SPRING ETC-P/R	P/R=Pressure Roller
SPRING(R)-CAU-HOT-FU	CAU-HOT-FU = Caution Hot -Fuser
PMO-ARM ACTUATOR	PMO-ARM= Processing Mold Arm
LABEL(R)-HV FUSER	HV=High Voltage (220V)
LABEL(R)-LV FUSER	LV=Low Voltage (110V)
PPR-SPONG SHEET	PPR=Plastic Press
IPR-P_PINCH(SCAN)I	PR-P = Iron Press
ROLLER-REGI	REGI=Registration
PBA SUB-REGI	PBA SUB-REGI => Sub Printed circuit Board Assembly for the Registration
GROUND-P_SCAN ROLLER	GROUND-P =Ground-Press
IPR-GUARD C/O S/W	C/O = Cover Open S/W= Switch
MEA UNIT-TX STACKER	TX =Transmit
IPR-WASHER SPRING CU	CU=Curve

## 6.3 The Sample Pattern for the Test

The sample pattern shown in below is the standard pattern used in the factory.  
 The life of the toner cartridge and the printing speed are measured using the pattern shown below.  
 (The image is 70% of the actual A4 size).

### 6.3.1 A4 ISO 19752 Standard Pattern

This test page is reproduced at 70% of the normal A4 size

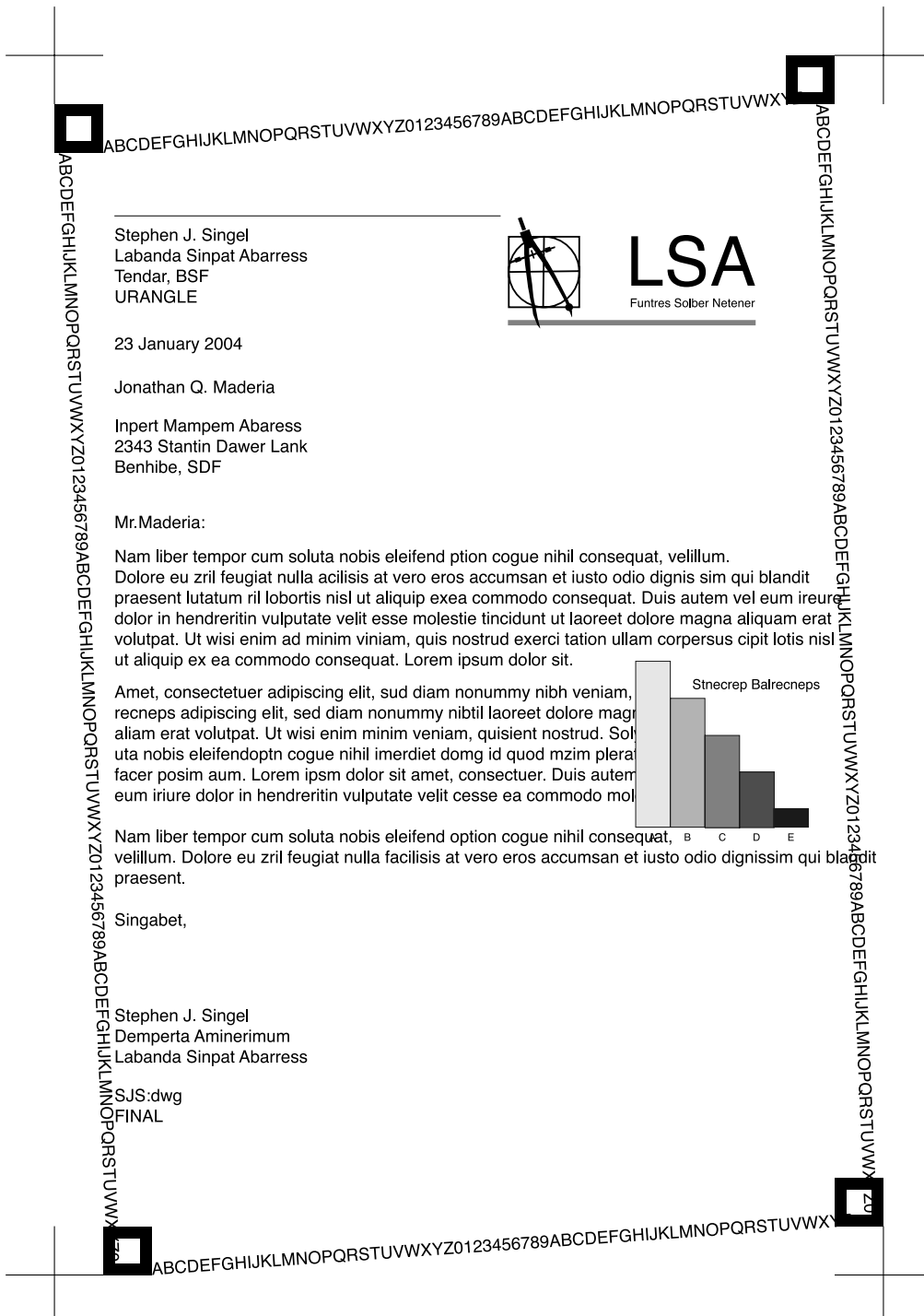



## 6.4 Selecting a location

Select a level, stable place with adequate space for air circulation. Allow extra space for opening covers and trays.

The area should be well-ventilated and away from direct sunlight or sources of heat, cold, and humidity. Do not set the machine close to the edge of your desk or table.

### Clearance space

- Front: 19 inches (enough space so that the paper tray can be removed)
- Back: 4 inches (enough space for ventilation)
- Right: 4 inches (enough space for ventilation)
- Left: 4 inches (enough space for ventilation)

