

**SAMSUNG**

Service Manual

# Service Manual

Service Manual

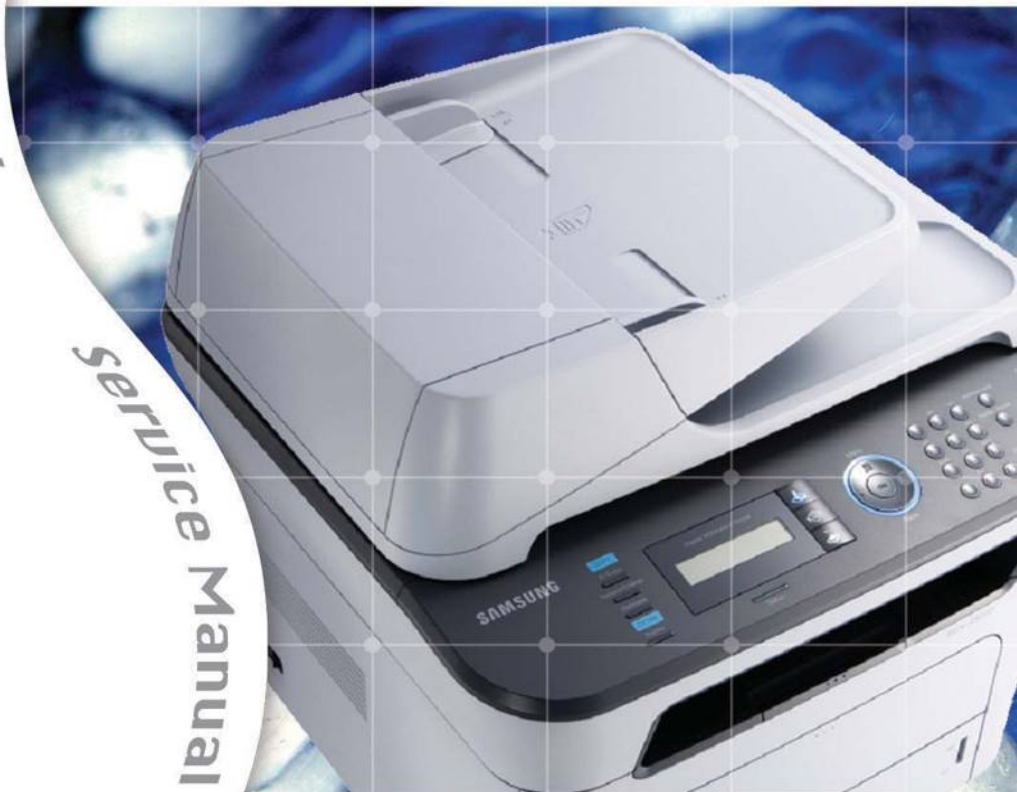

## DIGITAL LASER MFP

Model : SCX-4824FN/XBH

Basic : SCX-4824FN/SCX-4828FN

The keynote of Product

- Print/Copy Speed  
SCX-4824FN : 24 ppm (A4) / 24 cpm (A4)  
SCX-4828FN : 28 ppm (A4) / 28 cpm (A4)
- Print resolution  
: 1200 dpi effective output
- CPU : 360 Mhz
- PCL5e, PCL6, IBM ProPrinter, EPSON PS(4828FN)

- Memory  
SCX-4824FN : 64MB(Max. 320MB)  
SCX-4828FN : 128MB(Max. 384MB)
- ADF : 30(4824FN) / 50(4828FN) Sheet
- MP : 1 Sheet
- Toner : 2K(Initial)/ 5K(Sales)



**ELECTRONICS**

*Service Manual*

GSPN (Global Service Partner Network)

North America : [service.samsungportal.com](http://service.samsungportal.com)

Latin America : [latin.samsungportal.com](http://latin.samsungportal.com)

CIS : [cis.samsungportal.com](http://cis.samsungportal.com)

Europe : [europe.samsungportal.com](http://europe.samsungportal.com)

China : [china.samsungportal.com](http://china.samsungportal.com)

Asia : [asia.samsungportal.com](http://asia.samsungportal.com)

Mideast & Africa : [mea.samsungportal.com](http://mea.samsungportal.com)

© Samsung Electronics Co.,Ltd. September. 2008  
Printed in Korea.

**VERSION NO. : 1.00**

**CODE : 4824-FN0XBH**

## *chapter 1* *Precautions*

1.1 Safety Warning .....	1-1
1.2 Caution for safety .....	1-2
1.3 ESD Precautions .....	1-5
1.4 Super Capacitor or Lithium Battery Precautions .....	1-5

## *chapter 2* *Product spec and feature*

2.1 Product Specifications .....	2-1
2.1.1 Product Overview .....	2-1
2.1.2 Specifications .....	2-2
2.1.3 Model Comparison .....	2-9
2.2 Summary of Product .....	2-10
2.2.1 Printer Components .....	2-10
2.2.2 System Layout .....	2-12
2.2.3 Engine H/W Specifications .....	2-16
2.2.4 S/W Descriptions .....	2-27

## *chapter 3* *Disassembly and Reassembly*

3.1 Disassembly and Reassembly on Disassembly .....	3-1
3.1.1 Screws used in the printer .....	3-2
3.2 General Disassembly .....	3-3
3.2.1 Front Cover .....	3-3
3.2.2 Rear Cover .....	3-3
3.2.3 Right/Left Cover .....	3-4
3.2.4 Scan and ADF Assy .....	3-5
3.2.5 Middle Cover .....	3-9
3.2.6 Fuser .....	3-9
3.2.7 LSU .....	3-10
3.2.8 Main Drive Assy .....	3-10
3.2.9 HVPS/SMPS/Main board .....	3-11

---

3.2.10 Transfer roller .....	3-12
3.2.11 Holder Pad unit.....	3-13

## **chapter 4** *Alignment & Troubleshooting*

4.1 Alignment and Adjustments.....	4-1
4.1.1 Control Panel overview .....	4-1
4.1.2 Understanding The Status LED .....	4-2
4.1.3 Paper path .....	4-3
4.1.4 Menu Map .....	4-10
4.1.5 Tech Mode .....	4-12
4.1.6 EDC Mode .....	4-17
4.1.7 Abnormal Image Printing and Defective Roller .....	4-23
4.1.8 Error Message .....	4-24
4.2 Troubleshooting.....	4-28
4.2.1 Procedure of Checking the Symptoms .....	4-28
4.2.2 The cause and solution of Bad image.....	4-29
4.2.3 The cause and solution of the bad discharge .....	4-45
4.2.4 The cause and solution of the malfunction.....	4-53
4.2.5 The cause and solutions of bad environment of the software .....	4-62
4.2.6 Fax & Phone Problems .....	4-66
4.2.7 Copy Problems .....	4-75
4.2.8 Scanning Problems .....	4-79

## **chapter 5** *Exploded Views & Parts List*

Thumbnail .....	5-2
5.1 Main .....	5-3
5.2 Cover Ass'y .....	5-5
5.3 Cover Middle .....	5-7
5.4 Frame .....	5-9
5.5 Main Drive .....	5-15
5.6 Scan Ass'y .....	5-17

---

5.7 ADF Ass'y .....	5-19
5.8 Platen Ass'y .....	5-21
5.9 OPE Unit .....	5-23
5.10 Duplex Unit .....	5-25
5.11 Fuser.....	5-27
5.12 Cassette .....	5-30
5.13 SCF .....	5-32

## **chapter 6** *System Diagram*

6.1 Block Diagram .....	6-1
6.2 Connection Diagram.....	6-2

## **chapter 7** *Reference Information*

7.1 Tool for Troubleshooting .....	7-1
7.2 Acronyms and Abbreviations .....	7-2
7.2.1 Acronyms .....	7-2
7.2.2 Service Parts .....	7-4
7.3 The Sample Pattern for the Test.....	7-8
7.4 Selecting a location .....	7-9

---

# 1. Precautions

In order to prevent accidents and to prevent damage to the equipment please read the precautions listed below carefully before servicing the printer and follow them closely.

## 1.1 Safety Warning

- (1) Only to be serviced by appropriately qualified service engineers.

High voltages and lasers inside this product are dangerous. This printer should only be serviced by a suitably trained and qualified service engineer.

- (2) Use only Samsung replacement parts

There are no user serviceable parts inside the printer. Do not make any unauthorized changes or additions to the printer, these could cause the printer to malfunction and create electric shock or fire hazards.

- (3) Laser Safety Statement

The Printer is certified in the U.S. to conform to the requirements of DHHS 21 CFR, chapter 1 Subchapter J for Class 1(1) laser products, and elsewhere, it is certified as a Class I laser product conforming to the requirements of IEC 825. Class I laser products are not considered to be hazardous. The laser system and printer are designed so there is never any human access to laser radiation above a Class I level during normal operation, user maintenance, or prescribed service condition.

*Warning >> Never operate or service the printer with the protective cover removed from Laser/Scanner assembly. The reflected beam, although invisible, can damage your eyes. When using this product, these basic safety pre-cautions should always be followed to reduce risk of fire, electric shock, and injury to persons.*



CAUTION - INVISIBLE LASER RADIATION  
WHEN THIS COVER OPEN.  
DO NOT OPEN THIS COVER.

VORSICHT - UNSICHTBARE LASERSTRAHLUNG,  
WENN ABDECKUNG GE...FFNET.  
NICHT DEM STRAHL AUSSETZEN.

ATTENTION - RAYONNEMENT LASER INVISIBLE EN CAS  
D'OUVERTURE. EXPOSITION DANGEREUSE  
AU FAISCEAU.

ATTENZIONE - RADIAZIONE LASER INVISIBLE IN CASO DI  
APERTURA. EVITARE L'ESPOSIZIONE AL  
FASCIO.

PRECAUCION - RADIACION LASER IVISIBLE CUANDO SE ABRE.  
EVITAR EXPONERSE AL RAYO.

ADVARSEL - USYNLIG LASERSTRALNING VED BNING, NR  
SIKKERHEDSBRYDERE ER UDE AF FUNKTION.  
UNNG UDSAETTELSE FOR STRALNING.

ADVARSEL - USYNLIG LASERSTRALNING NR DEKSEL  
PNES. STIRR IKKE INN I STRLEN.  
UNNG EKSPONERING FOR STRLEN.

VARNING - OSYNLIG LASERSTRALNING NR DENNA DEL  
R...PPNAD OCH SPRREN R URKOPPLAD.  
BETRAKTA EJ STRLEN. STRLEN R FARLIG.

VARO! - AVATTAESSA JA SUOJALUKITUS OHITETTAESSA  
OLET ALTIINA NKYMTT...MLLE LASER-  
STEILYLLE L KATSO STEESEEN.

**注 意** - 严禁揭开此盖, 以免激光泄露灼伤

주 의 - 이 덮개를 열면 레이저광에 노출될 수 있으므로  
주의하십시오.

## 1.2 Caution for safety

### 1.2.1 Toxic material

This product contains toxic materials that could cause illness if ingested.

- (1) If the LCD control panel is damaged it is possible for the liquid inside to leak. This liquid is toxic. Contact with the skin should be avoided, wash any splashes from eyes or skin immediately and contact your doctor. If the liquid gets into the mouth or is swallowed see a doctor immediately.
- (2) Please keep Drum cartridge and Toner Cartridge away from children. The toner powder contained in the Drum cartridge and Toner Cartridge may be harmful and if swallowed you should contact a doctor.

### 1.2.2 Electric Shock and Fire Safety Precautions

Failure to follow the following instructions could cause electric shock or potentially cause a fire.

- (1) Use only the correct voltage, failure to do so could damage the printer and potentially cause a fire or electric shock.
- (2) Use only the power cable supplied with the printer. Use of an incorrectly specified cable could cause the cable to overheat and potentially cause a fire.
- (3) Do not overload the power socket, this could lead to overheating of the cables inside the wall and could lead to a fire.
- (4) Do not allow water or other liquids to spill into the printer, this can cause electric shock. Do not allow paper clips, pins or other foreign objects to fall into the printer these could cause a short circuit leading to an electric shock or fire hazard.
- (5) Never touch the plugs on either end of the power cable with wet hands, this can cause electric shock. When servicing the printer remove the power plug from the wall socket.
- (6) Use caution when inserting or removing the power connector. The power connector must be inserted completely otherwise a poor contact could cause overheating possibly leading to a fire. When removing the power connector grip it firmly and pull.
- (7) Take care of the power cable. Do not allow it to become twisted, bent sharply round corners or otherwise damaged. Do not place objects on top of the power cable. If the power cable is damaged it could overheat and cause a fire or exposed cables could cause an electric shock. Replace a damaged power cable immediately, do not reuse or repair the damaged cable. Some chemicals can attack the coating on the power cable, weakening the cover or exposing cables causing fire and shock risks.
- (8) Ensure that the power sockets and plugs are not cracked or broken in any way. Any such defects should be repaired immediately. Take care not to cut or damage the power cable or plugs when moving the machine.
- (9) Use caution during thunder or lightening storms. Samsung recommend that this machine be disconnected from the power source when such weather conditions are expected. Do not touch the machine or the power cord if it is still connected to the wall socket in these weather conditions.
- (10) Avoid damp or dusty areas, install the printer in a clean well ventilated location. Do not position the machine near a humidifier. Damp and dust build up inside the machine can lead to overheating and cause a fire.
- (11) Do not position the printer in direct sunlight. This will cause the temperature inside the printer to rise possibly leading to the printer failing to work properly and in extreme conditions could lead to a fire.
- (12) Do not insert any metal objects into the machine through the ventilator fan or other part of the casing, it could make contact with a high voltage conductor inside the machine and cause an electric shock.

## 1.2.3 Handling Precautions

---

The following instructions are for your own personal safety, to avoid injury and so as not to damage the printer

- (1) Ensure the printer is installed on a level surface, capable of supporting its weight. Failure to do so could cause the printer to tip or fall.
- (2) The printer contains many rollers, gears and fans. Take great care to ensure that you do not catch your fingers, hair or clothing in any of these rotating devices.
- (3) Do not place any small metal objects, containers of water, chemicals or other liquids close to the printer which if spilled could get into the machine and cause damage or a shock or fire hazard.
- (4) Do not install the machine in areas with high dust or moisture levels, beside an open window or close to a humidifier or heater. Damage could be caused to the printer in such areas.
- (5) Do not place candles, burning cigarettes, etc on the printer, These could cause a fire.

## 1.2.4 Assembly / Disassembly Precautions

---

Replace parts carefully, always use Samsung parts. Take care to note the exact location of parts and also cable routing before dismantling any part of the machine. Ensure all parts and cables are replaced correctly. Please carry out the following procedures before dismantling the printer or replacing any parts.

- (1) Check the contents of the machine memory and make a note of any user settings. These will be erased if the mainboard or network card is replaced.
- (2) Ensure that power is disconnected before servicing or replacing any electrical parts.
- (3) Disconnect printer interface cables and power cables.
- (4) Only use approved spare parts. Ensure that part number, product name, any voltage, current or temperature rating are correct.
- (5) When removing or re-fitting any parts do not use excessive force, especially when fitting screws into plastic.
- (6) Take care not to drop any small parts into the machine.
- (7) Handling of the OPC Drum
  - The OPC Drum can be irreparably damaged if it is exposed to light. Take care not to expose the OPC Drum either to direct sunlight or to fluorescent or incandescent room lighting. Exposure for as little as 5 mins can damage the surface's photoconductive properties and will result in print quality degradation. Take extra care when servicing the printer. Remove the OPC Drum and store it in a black bag or other lightproof container. Take care when working with the covers (especially the top cover) open as light is admitted to the OPC area and can damage the OPC Drum.
  - Take care not to scratch the green surface of the OPC Drum Unit. If the green surface of the Drum Cartridge is scratched or touched the print quality will be compromised.



### **1.2.5 Disregarding this warning may cause bodily injury**

- (1) Be careful with the high temperature part.  
The fuser unit works at a high temperature. Use caution when working on the printer. Wait for the fuser to cool down before disassembly.
- (2) Do not put finger or hair into the rotating parts.  
When operating a printer, do not put hand or hair into the rotating parts (Paper feeding entrance, motor, fan, etc.). If do, you can get harm.
- (3) When you move the printer
  - When transporting/installing the equipment be sure to hold the positions as shown in the reference chapter.  
The equipment is quite heavy and weighs approximately 13.6 Kg (including consumables), therefore pay full attention when handling it.
  - Be sure not to hold the movable parts or units (e.g. the control panel, DADF) when transporting the equipment.
  - Be sure to use a dedicated outlet with 110V/220V power input.
  - The equipment must be grounded for safety.
  - Select a suitable place for installation. Avoid excessive heat, high humidity, dust, vibration and direct sunlight.
  - Provide proper ventilation since the equipment emits a slight amount of ozone.
  - To insure adequate working space for the copying operation, keep a minimum clearance of 10cm (3.9" on the left, 10 cm (3.9") on the right and 18 cm (7.1") on the rear.
  - The equipment shall be installed near the socket outlet and shall be accessible.
  - Be sure to fix and plug in the power cable securely after the installation so that no one trips over it.

## 1.3 ESD Precautions

---

Certain semiconductor devices can be easily damaged by static electricity. Such components are commonly called “Electrostatically Sensitive (ES) Devices” or ESDs. Examples of typical ESDs are: integrated circuits, some field effect transistors, and semiconductor “chip” components.

The techniques outlined below should be followed to help reduce the incidence of component damage caused by static electricity.

*Caution >>Be sure no power is applied to the chassis or circuit, and observe all other safety precautions.*

1. Immediately before handling a semiconductor component or semiconductor-equipped assembly, drain off any electrostatic charge on your body by touching a known earth ground. Alternatively, employ a commercially available wrist strap device, which should be removed for your personal safety reasons prior to applying power to the unit under test.
2. After removing an electrical assembly equipped with ESDs, place the assembly on a conductive surface, such as aluminum or copper foil, or conductive foam, to prevent electrostatic charge buildup in the vicinity of the assembly.
3. Use only a grounded tip soldering iron to solder or desolder ESDs.
4. Use only an “anti-static” solder removal device. Some solder removal devices not classified as “anti-static” can generate electrical charges sufficient to damage ESDs.
5. Do not use Freon-propelled chemicals. When sprayed, these can generate electrical charges sufficient to damage ESDs.
6. Do not remove a replacement ESD from its protective packaging until immediately before installing it. Most replacement ESDs are packaged with all leads shorted together by conductive foam, aluminum foil, or a comparable conductive material.
7. Immediately before removing the protective shorting material from the leads of a replacement ESD, touch the protective material to the chassis or circuit assembly into which the device will be installed.
8. Maintain continuous electrical contact between the ESD and the assembly into which it will be installed, until completely plugged or soldered into the circuit.
9. Minimize bodily motions when handling unpackaged replacement ESDs. Normal motions, such as the brushing together of clothing fabric and lifting one’s foot from a carpeted floor, can generate static electricity sufficient to damage an ESD.

## 1.4 Super Capacitor or Lithium Battery Precautions

---

1. Exercise caution when replacing a super capacitor or Lithium battery. There could be a danger of explosion and subsequent operator injury and/or equipment damage if incorrectly installed.
2. Be sure to replace the battery with the same or equivalent type recommended by the manufacturer.
3. Super capacitor or Lithium batteries contain toxic substances and should not be opened, crushed, or burned for disposal.
4. Dispose of used batteries according to the manufacture? instructions.

## 2. Product spec and feature

### 2.1 Product Specifications

#### 2.1.1 Product Overview

**Concept**

Optimized Desktop MFP for Small Workgroup

**Target**

Entry SMB

**SCX-4824FN**

- 24 ppm (A4)
- Print Resolution  
: Addressable 1200 x 1,200 dpi
- USB 2.0, N/W
- 250 Cassette, 1 Manual Tray
- ID Copy, Clone/Poster Copy
- Initial : 2K, Sales : 5K
- Optional 250 Cassette

**SCX-4828FN**

- 28ppm (A4), 30ppm(Ltr.)
- Duplex : 14 ppm ( A4)
- Print Resolution  
: Addressable 1200 x 1,200 dpi
- USB 2.0, N/W
- 250 Cassette, 1 Manual Tray
- Direct USB
- ID Copy, Clone/Poster Copy
- Initial : 2K, Sales : 5K
- Standard Duplex: Print
- Optional 250 Cassette

## 2.1.2 Specifications

- Product Specifications are subject to change without notice. See below for product specifications.

### 2.1.2.1 General Print Engine

Items	SCX-4824FN	SCX-4828FN
Net Dimension (W x D x H)	445.2 x 410.5 x 395.3mm (17.53 x 16.16 x 15.56 in)	445.2 x 410.5 x 395.3mm (17.53 x 16.16 x 15.56 in)
Packing Dimension (W x D x H)		
Weight with Consumables	13.6Kg(w/o Consumable 12.7Kg)	13.6Kg(w/o Consumable 12.7Kg)
Packing Weight		
LCD	2 line x 16 characters	2 line x 16 characters
System Memory	64 MB	128 MB
Interface	Hi-Speed USB 2.0, Ethernet 10/100 Base TX	Hi-Speed USB 2.0, Ethernet 10/100 Base TX
OS Compatibility *****	Windows 2000(32bit)/XP(32/64bit)/2003 Server(32/64bit)/Vista(32/64bit) Various Linux OS including Red Hat 8~9, Fedora Core 1~4, Mandrake 9.2~10.1, and SuSE 8.2~9.2 Mac 10.3, 10.4, 10.5	Windows 2000(32bit)/XP(32/64bit)/2003 Server(32/64bit)/Vista(32/64bit) Various Linux OS including Red Hat 8~9, Fedora Core 1~4, Mandrake 9.2~10.1, and SuSE 8.2~9.2 Mac 10.3, 10.4, 10.5
WHQL	Windows 2000, XP, 2003 Server, Vista(32/64bits)	Windows 2000, XP, 2003 Server, Vista(32/64bits)
Wired network Protocol	TCP/IP, Ethertalk, SNMP, HTTP 1.1	TCP/IP, Ethertalk, SNMP, HTTP 1.1
Wired network Supporting OS	Windows 2000/XP(32/64bits)/2003 Server/Vista(32/64bits) NetWare 5.x, 6.x Mac OS 8.6~9.2, 10.1~10.4 Various Linux OS including Red Hat 8~9, Fedora Core 1~4, Mandrake 9.2~10.1, SuSE 8.2~9.2 Unix AT&T system V(Rel 4.2), BSD4.3, HP-UX (Rel 9.x & Rel 10.x), SCO 5.x, SUNOS 5.5, Sparc or Solaris 2.5.	Windows 2000/XP(32/64bits)/2003 Server/Vista(32/64bits) NetWare 5.x, 6.x Mac OS 8.6~9.2, 10.1~10.4 Various Linux OS including Red Hat 8~9, Fedora Core 1~4, Mandrake 9.2~10.1, SuSE 8.2~9.2 Unix AT&T system V(Rel 4.2), BSD4.3, HP-UX (Rel 9.x & Rel 10.x), SCO 5.x, SUNOS 5.5, Sparc or Solaris 2.5.
Noise *****	Warm up : Less than 45dBA Stand by : Less than 26 dBA Printing : Less than 49 dBA Coping : Less than 53 dBA	Warm up : Less than 45dBA Stand by : Less than 26 dBA Printing : Less than 50 dBA Coping : Less than 53 dBA
Power Requirement	110 ~ 127 VAC, 50/60 Hz, 9.0A 220 ~ 240 VAC, 50/60 Hz, 4.5A	110 ~ 127 VAC, 50/60 Hz, 9.0A 220 ~ 240 VAC, 50/60 Hz, 4.5A
Operating Conditions	Temperature : 10°C ~ 32°C (50°C ~ 89°C) Humidity : 20% ~ 80% RH	Temperature : 10°C ~ 32°C (50°C ~ 89°C) Humidity : 20% ~ 80% RH

Items	SCX-4824FN	SCX-4828FN
Power Consumption	Ready : Less than 70W Average : Less than 400W Max/Peak : 700W Sleep/power off : Less than 8.5W	Ready : Less than 70W Average : Less than 400W Max/Peak : 700W Sleep/power off : Less than 8.5W
AMPV	592 sheets	592 sheets
Duty Cycle, monthly	Up to 30,000 pages	Up to 50,000 pages
MTBF	Up to 50,000 pages	Up to 50,000 pages
MTTR	30 min.	30 min.
SCANLife Cycle	20,000 sheets or 5 years (whichever comes first)	20,000 sheets or 5 years (whichever comes first)
ADF Life Cycle	20,000 sheets or 5 years (whichever comes first)	20,000 sheets or 5 years (whichever comes first)
SET Life Cycle	100,000 sheets or 5 years (whichever comes first)	100,000 sheets or 5 years (whichever comes first)

### 2.1.2.2 Print Specifications

Items	SCX-4824FN	SCX-4828FN
Method	Laser Beam Printing	Laser Beam Printing
Speed (Simplex)	Up to 24 ppm (A4)	Up to 28 ppm (A4)
Speed (Duplex)	-	Up to 14 ppm (A4)
F POT	Less than 17s (from sleep mode) Less than 9.5s (from stanby mode)	Less than 16s (from sleep mode) Less than 8.5s (from stanby mode)
Warm-up(from sleep)	Less than 15s	Less than 15s
Resolution	Up to 1200dpi Effective Output (Addressable 1200x1200dpi)	Up to 1200dpi Effective Output (Addressable 1200x1200dpi)
Processor	Chorus3 360MHz	Chorus3 360MHz
Memory	64MB(Max. 320MB)	128MB(Max. 384MB)
Emulation	PCL5e, PCL6, IBM ProPrinter, EPSON	PCL5e, PCL6, IBM ProPrinter, EPSON, PS3
Font	45 scalable, 1 bitmap, 136 PostScript3 fonts	45 scalable, 1 bitmap, 136 PostScript3 fonts
Duplex Print	N/A	Default

### 2.1.2.3 Copy Specifications

Items	SCX-4824FN	SCX-4828FN
Speed **	SDMC: up to 24 cpm in A4 (25 cpm in Letter) MDSC: up to 12 cpm in A4 (13 cpm in Letter)	SDMC: up to 28 cpm in A4 (30 cpm in Letter) MDSC: up to 12 cpm in A4 (13 cpm in Letter)
Resolution (Optical)	600 x 600dpi Text, Text/Photo : 600 x 600dpi Photo mode : 1200 x 1200dpi	1200 x 1200dpi Text, Text/Photo : 600 x 600dpi Photo mode : 1200 x 1200dpi
Resolution (Enhanced)	4800 x 4800 dpi	4800 x 4800 dpi
FCOT(from Standby mode)	Approx. 15 seconds :Platen Approx. 14 seconds :ADF	Approx. 15 seconds :Platen Approx. 14 seconds :ADF
Zoom Rate	25~400% (platen), 25~100% (ADF)	25~400% (platen), 25~100% (ADF)
Multy Copy	1~99 pages	1~99 pages
Special Copy	N-up copy : 2-up / 4-up Collation Copy : Yes AutoFit Copy : Yes(Platen only) 2-side Copy : Yes(Platen only) Clone : Yes(Platen only) Poster : Yes(Platen only)	N-up copy : 2-up / 4-up Collation Copy : Yes AutoFit Copy : Yes(Platen only) 2-side Copy : Yes(Platen only) Clone : Yes(Platen only) Poster : Yes(Platen only)
Duplex Copy	N/A	N/A

### 2.1.2.4 Scan Specifications

Items	SCX-4824FN	SCX-4828FN
Compatibility	Twain Standard, WIA Standard	Twain Standard, WIA Standard
Method	Color CIS	Color CIS
Scan Speed through ADF	Linearity : Approx. 20sec Gray : Approx. 20sec Color : Approx. 64sec	Linearity : Approx. 20sec Gray : Approx. 20sec Color : Approx. 64sec
Scan Speed through Platen	Linearity : Approx. 25sec Gray : Approx. 25sec Color : Approx. 65sec	Linearity : Approx. 25sec Gray : Approx. 25sec Color : Approx. 65sec
Resolution(Optical)	600 x 600 dpi	1200 x 1200 dpi(Platen PC SCAN)
Resolution(Enhanced)	4800 x 4800 dpi	4800 x 4800 dpi
Effective Scan Length	297 mm (11.7")	297 mm (11.7")
Effective Scan Width	208mm (8.2")	208mm (8.2")
Color Bit depth	Internal : 24 bit, External : 24 bit	Internal : 24 bit, External : 24 bit
B/W Bit depth	1 bit for Text mode, 8 bit for Gray mode	1 bit for Text mode, 8 bit for Gray mode
Gray Scale	256 Levels	256 Levels

## 2.1.2.5 Fax Specifications

Items	SCX-4824FN	SCX-4828FN
Compatibility	ITU-T Group 3, ECM	ITU-T Group 3, ECM
Applicable line	Public Switched Telephone Network (PSTN) or behind PABX	Public Switched Telephone Network (PSTN) or behind PABX
Modem Speed	33.6 Kbps	33.6 Kbps
Transmission Speed ***	Approx. 3 seconds per page	Approx. 3 seconds per page
Compression Mode	MH/ MR/ MMR/ JBIG/ JPEG	MH/ MR/ MMR/ JBIG/ JPEG
Scan Speed ****	Std : Approx. 2.5 seconds per page (LTR) Fine/S.Fine : Approx. 5 seconds per page (LTR)	Std : Approx. 2.5 seconds per page (LTR) Fine/S.Fine : Approx. 5 seconds per page (LTR)
Resolution	Max. 300 x 300 dpi Standard : 203 x 98 dpi Fine : 203 x 196 dpi Super Fine : 300 x 300 dpi Photo : 203 x 196 dpi Color : 200 x 200 dpi	Max. 300 x 300 dpi Standard : 203 x 98 dpi Fine : 203 x 196 dpi Super Fine : 300 x 300 dpi Photo : 203 x 196 dpi Color : 200 x 200 dpi
Memory	3.2 MB (Approx. 260 pages at ITU-T #1 Chart) Max locations to store to 1 Group Dial : 199 locations Fax Forward : Yes(On/Off) Broadcasting : up to 209 locations Cover page : Yes Delayed fax : Yes Memory RX : Yes	3.2 MB (Approx. 260 pages at ITU-T #1 Chart) Max locations to store to 1 Group Dial : 199 locations Fax Forward : Yes(On/Off) Broadcasting : up to 209 locations Cover page : Yes Delayed fax : Yes Memory RX : Yes
Functions	Voice Request : No TTI : Yes RTI : Yes Polling :No Earth/Recall :No Auto Reduction : Yes F/W Remote upgrade :Yes	Voice Request : No TTI : Yes RTI : Yes Polling :No Earth/Recall :No Auto Reduction : Yes F/W Remote upgrade :Yes
Junk Fax barrier	Yes	Yes
Secure Receive	Yes	Yes
Memory Back-up	Yes, Max. 72hours	Yes, Max. 72hours
Auto Dial	Up to 200 Locaions	Up to 200 Locaions

## 2.1.2.6 Paper Handling

Items	SCX-4824FN	SCX-4828FN
Standard Capacity	250-sheet Cassette Tray, 1-sheet Multi Purpose Tray @80g/m <sup>2</sup>	250-sheet Cassette Tray, 1-sheet Multi Purpose Tray @80g/m <sup>2</sup>
Maximum Capacity	501 sheets @ 80g/m <sup>2</sup>	501 sheets @ 80g/m <sup>2</sup>
Printing Max. Size	216 x 356 mm (8.5" x 14")	216 x 356 mm (8.5" x 14")
Min. Size	76 x 127 mm (3.0" x 5.0")	76 x 127 mm (3.0" x 5.0")
1st Tray Capacity	250 sheets @ 80g/m <sup>2</sup>	250 sheets @ 80g/m <sup>2</sup>
Media Sizes	A4, A5, Letter, Legal, Executive, Folio, Oficio, ISO B5, JIS B5	A4, A5, Letter, Legal, Executive, Folio, Oficio, ISO B5, JIS B5
Media types	Plain paper, Thick Paper, Thin Paper, Recycled Paper, Archive Paper	Plain paper, Thick Paper, Thin Paper, Recycled Paper, Archive Paper
Media weight	16~28lb (60 to 105g/m <sup>2</sup> )	16~28lb (60 to 105g/m <sup>2</sup> )
Sensing	Paper empty sensor	Paper empty sensor
2nd Tray Capacity	250 sheets @ 80g/m <sup>2</sup>	250 sheets @ 80g/m <sup>2</sup>
Media Sizes	A4, Letter, Legal, Folio, Oficio	A4, Letter, Legal, Folio, Oficio
Media types	Plain paper, Thick Paper, Thin Paper, Recycled Paper, Archive Paper	Plain paper, Thick Paper, Thin Paper, Recycled Paper, Archive Paper
Media weight	16~28lb (60 to 105g/m <sup>2</sup> )	16~28lb (60 to 105g/m <sup>2</sup> )
Sensing	Paper empty sensor	Paper empty sensor
Manual Tray Capacity	1 sheets @ 80g/m <sup>2</sup>	1 sheets @ 80g/m <sup>2</sup>
Media Sizes	A4, A5, A6, Letter, Legal, Folio, Oficio, Executive, ISO B5, JIS B5, 3"x5", Monarch, No.10, DL, C5, C6	A4, A5, A6, Letter, Legal, Folio, Oficio, Executive, ISO B5, JIS B5, 3"x5", Monarch, No.10, DL, C5, C6
Media types	Plain paper, Thick Paper, Thin Paper, Recycled Paper, Archive Paper, Transparency, Envelope, Labels, Post Card, Card stock	Plain paper, Thick Paper, Thin Paper, Recycled Paper, Archive Paper, Transparency, Envelope, Labels, Post Card, Card stock
Media weight	16~43lb (60 to 163g/m <sup>2</sup> )	16~43lb (60 to 163g/m <sup>2</sup> )
Sensing	NA	NA
Output Stacking	100 sheets @ 75g/m <sup>2</sup> (Base Line Paper : Samsung Premium/Xerox4200) NN Condition	150 sheets @ 75g/m <sup>2</sup> (Base Line Paper : Samsung Premium/Xerox4200) NN Condition
Duplex Media sizes	-	A4, Letter, Legal, Folio, Oficio
Media Types	-	Plain paper, Thick Paper, Thin Paper, Recycled Paper, Archive Paper
Media weight	-	20~24lb (75 to 90g/m <sup>2</sup> )
Printable Area	Envelop : 10mm(0.4") from edge(Top, Bottom, Left, Right)	Envelop : 10mm(0.4") from edge(Top, Bottom, Left, Right)
Non-Printable Area	Other Media : 4mm(0.16") from edge(Top, Bottom, Left, Right)	Other Media : 4mm(0.16") from edge(Top, Bottom, Left, Right)
ADF Capacity	30 sheets (Letter / A4, 20 lb / 75 g/m <sup>2</sup> )	50 sheets (Letter / A4, 20 lb / 75 g/m <sup>2</sup> )



Items	SCX-4824FN	SCX-4828FN
ADF Document Size	Width: 142 ~ 216mm (5.6"~8.5") Length : 148 ~ 356mm (5.8" ~ 14.0")	Width: 142 ~ 216mm (5.6"~8.5") Length : 148 ~ 356mm (5.8" ~ 14.0")
Media Size (for Fax and Copy)	Letter, A4, Legal	Letter, A4, Legal

### 2.1.2.7 Consumables (CRU)

Items	SCX-4824FN	SCX-4828FN
Type	Single Cartridge	Single Cartridge
Yield	Standard: Average Cartridge Yield 2K standard pages. High Yield: Average cartridge Yield 5K standard pages. Declared cartridge yield in accordance with ISO/IEC 19752.	Standard: Average Cartridge Yield 2K standard pages. High Yield: Average cartridge Yield 5K standard pages. Declared cartridge yield in accordance with ISO/IEC 19752.
Life Detect	Toner gauge sensor by dot count	Toner gauge sensor by dot count
Key	Electronic key(CRUM) Only	Electronic key(CRUM) Only
Code	MLT-D209S/MLT-D209L	MLT-D209S/MLT-D209L

### 2.1.2.8 Consumables (FRU)

Image	Items	Life	Part code
	Transfer roller	50K	JC66-01218A
	Fuser	50K	JC96-05132A(220V) JC96-05133A(110V)
	Pick up rubber	50K	JC97-03062A
	Friction Pad (Cassette)	50K	JC96-04743A
	Friction Pad (ADF)	20K	JC97-01940A
	Pick up Assy(ADF)	20K	JC97-01962A

### 2.1.2.9 Options

Items	SCX-4824FN	SCX-4828FN
Network	N/A	N/A
Memory	128MB / 256MB (CLP-MEM101/ CLP-MEM102)	128MB / 256MB (CLP-MEM101/ CLP-MEM102)
SCF	Option (SCX-S4824A)	Option (SCX-S4824A)
PS	N/A	Standard

\* Print speed will be affected by Operating system used, computing performance, application software, connecting method, media type, media size and job complexity.

\*\* Copy Speed is based on Single Document Multiple Copy

\*\*\* Condition: Standard resolution, MMR(JBIG), Maximum modem speed, Phase "C" by ITU-T No.1 Chart, Memory Tx, ECM



\*\*\*\* Condition: ITU-T No.1 Chart, Standard Resolution

\*\*\*\*\* Please visit [www.samsungprinter.com](http://www.samsungprinter.com) to download the latest software version.

\*\*\*\*\* Sound Pressure Level, ISO7779

\*\*\*\*\* May be affected by operating environment, printing interval, media type and media size

## 2.1.3 Model Comparison

		Samsung SCX-4824FN	Samsung SCX-4728FN	HP M2727nf
Image				
Printer	Speed	24 ppm (A4)	28 ppm (A4)	26 ppm (A4)
	FPOT	17 sec	16 sec	10 sec
	Cassette	250 sheets	250 sheets	300 sheets
	Duplex Module	N/A	Default	N/A
	Cartridge	2K/5K	2K/5K	Sales : 3K/7K
	Processor	360MHz	360MHz	450MHz
	Memory	64MB(Max.320MB)	128MB(Max.384MB)	64MB(Max. 320MB)
	Interface	USB 2.0 / 10/100 TX	USB 2.0 / 10/100 TX	USB 2.0 / 10/100 TX
	Emulation	PCL6,PCL5e	PCL6,PCL5e,PS	PCL6,PCL5e,PS
FAX	Modem Speed	33.6 kbps	33.6 kbps	33.6 kbps
Scan	Resolution (Scan)	600*600 dpi	1200*1200 dpi	1200 dpi
	Input capacity (ADF)	30 sheets	50 sheets	50 sheets
Copy	Copy Speed	SDMC: up to 24cpm MDSC: up to 12cpm	SDMC: up to 24cpm MDSC: up to 12cpm	26 cpm
USB HOST		NA	Direct USB support	
Dimension		445.2 x 410.5 x 395.3mm	445.2 x 410.5 x 395.3mm	500x406x457mm
Weight		13.6Kg	13.6Kg	17.2Kg

## 2.2 Summary of Product

This chapter describes the functions and operating principal of the main component.

### 2.2.1 Printer Components

#### 2.2.1.1 Front View

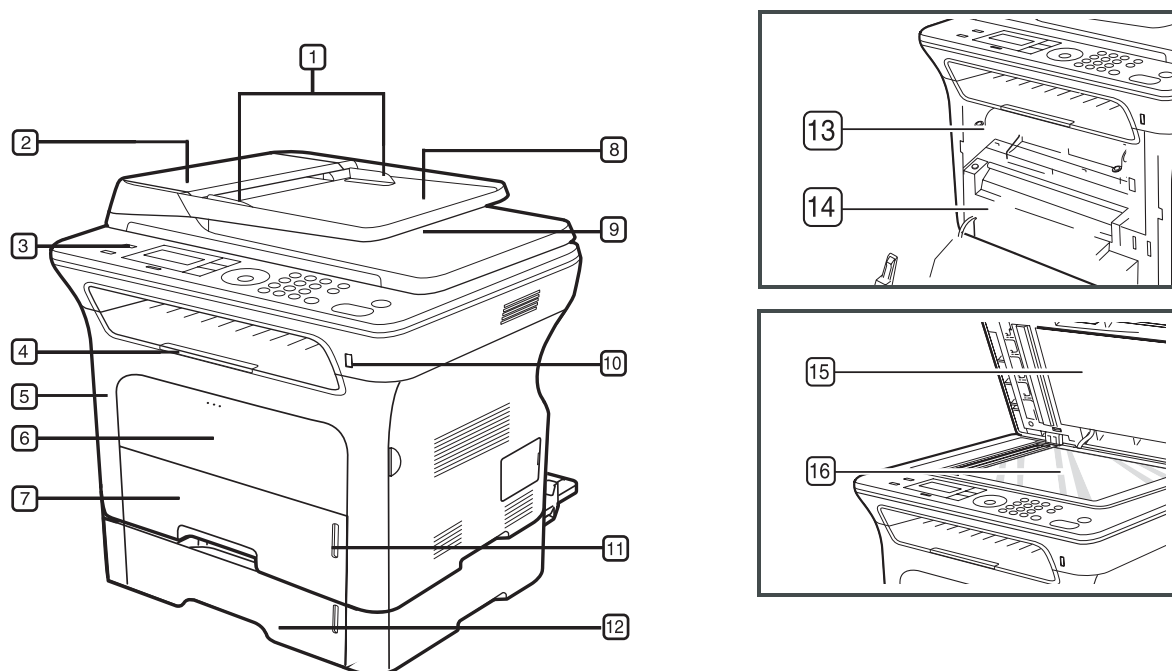

1	Document width guides	9	Document output tray
2	ADF cover	10	USB memory port
3	Control panel	11	Paper level indicator
4	Output support	12	Optional tray 2
5	Front cover	13	Toner cartridge
6	Manual tray	14	Manual tray paper width guides
7	Tray 1	15	Scanner lid
8	Document input tray	16	Scanner glass

### 2.2.1.2 Rear View

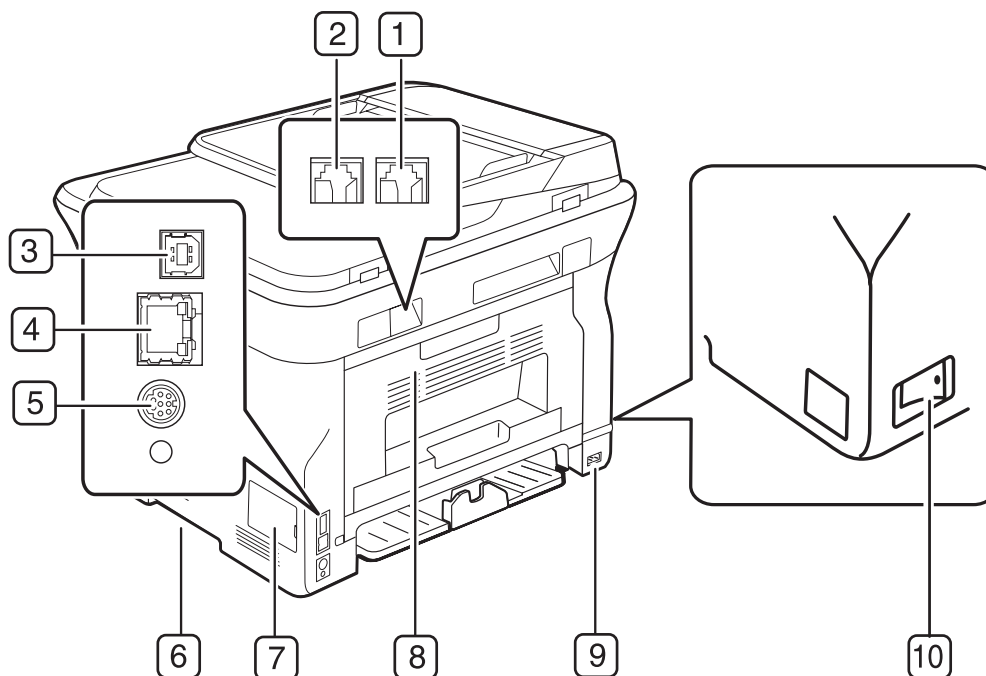

<b>1</b>	<b>Extension telephone socket (EXT)</b>	<b>6</b>	<b>Handle</b>
<b>2</b>	<b>Telephone line socket</b>	<b>7</b>	<b>Control board cover</b>
<b>3</b>	<b>USB port</b>	<b>8</b>	<b>Rear cover</b>
<b>4</b>	<b>Network port</b>	<b>9</b>	<b>Power receptacle</b>
<b>5</b>	<b>15-pin optional tray connection</b>	<b>10</b>	<b>Power switch</b>

## 2.2.2 System Layout

### - Engine Layout

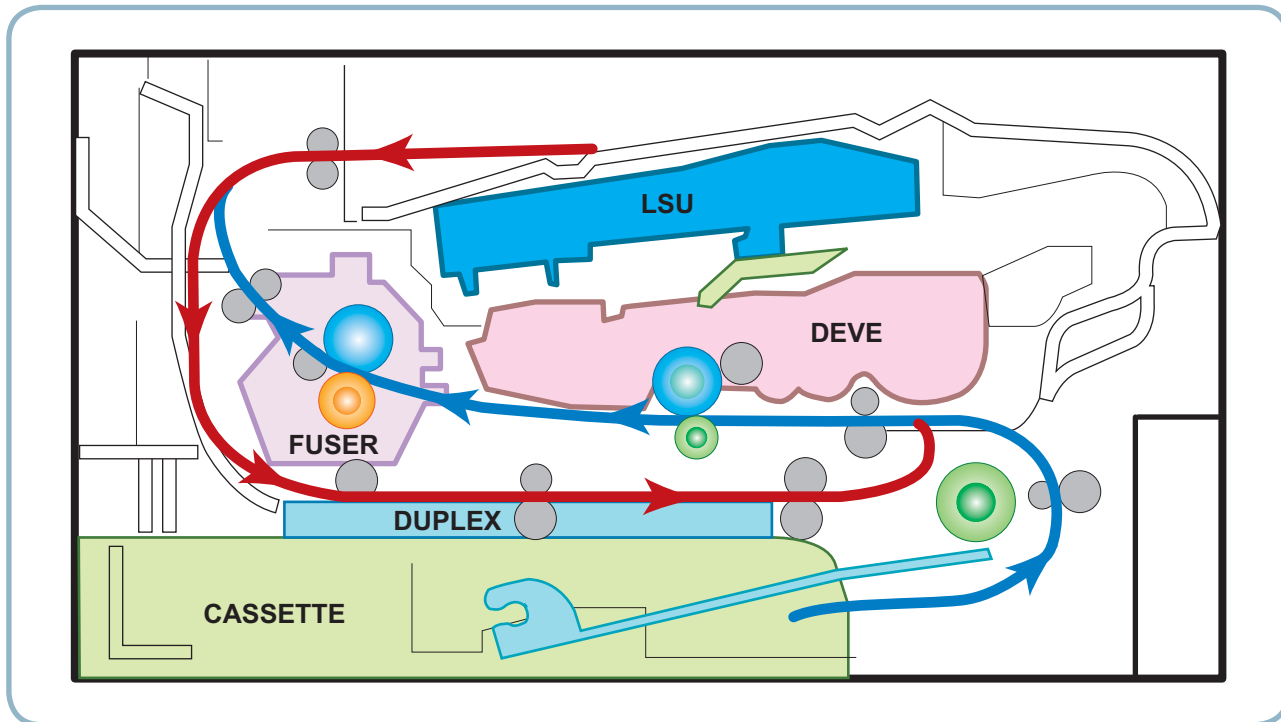

### - Scanner (ADF) Layout

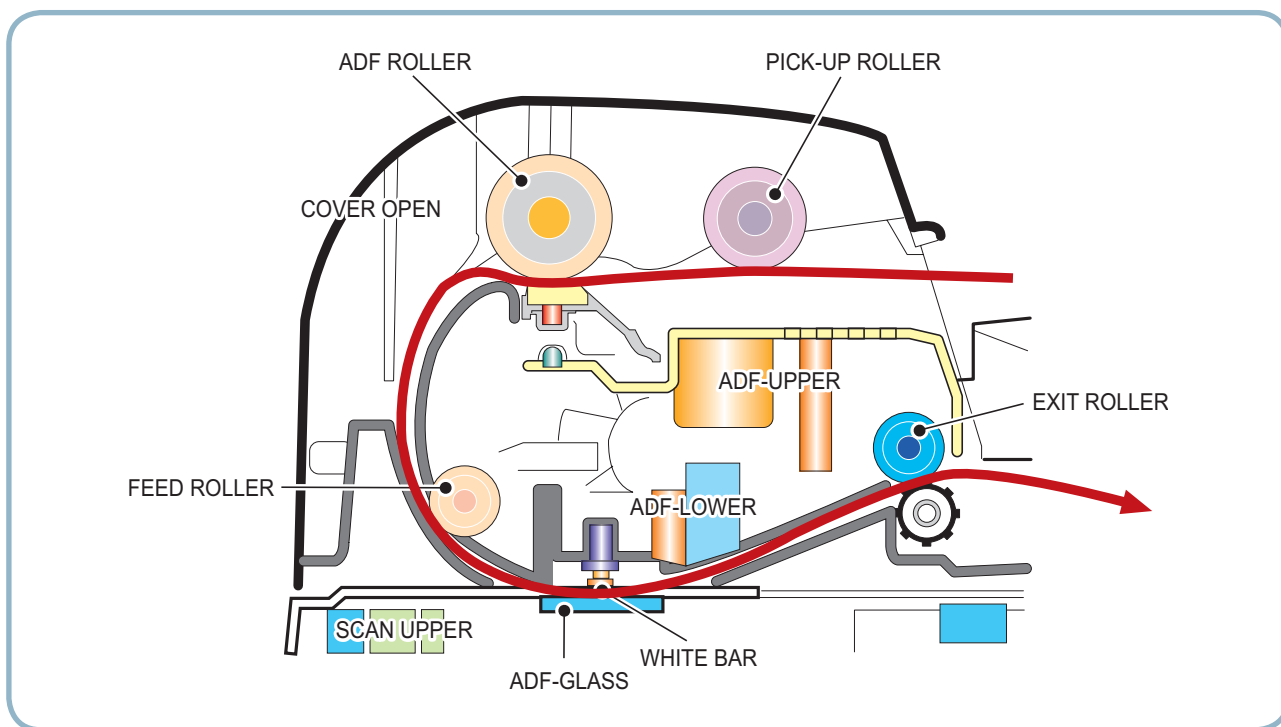

### 2.2.2.1 Feeding

---

It consists of a basic cassette, an MP tray for supplying different types of media (envelope, label, special paper) duplex unit, and parts related to paper transferring.

#### 1) Separation method

Separate it from the friction pad mounted to the center of the cassette.

#### 2) Basic cassette

It takes a center loading method and applies 'friction pad separating method.'

Both the side guide and the rear guide can be adjusted for various types of papers from A5 to legal size paper.

It has a paper existence sensing function (Capacity: 250 sheets of general paper), paper arranging function, various size papers accepting function, SCF paper path function, and displaying function of paper remaining amount.

In the front side, there is a paper level indicator.

#### 3) Pick-up roller

It has functions such as a paper pickup function, driving control function, paper feeding function, and removing electronic static function.

#### 4) Registration roller

It has a paper arranging function, paper transferring function, paper detecting function, jam removing function, and so on.

#### 5) MP tray

It has a paper arranging function, paper transferring function, jam removing function, and so on.

It uses rubbing pad method to feed 1 sheets of general papers and 1 envelopes.

#### 6) Duplex unit

It has paper transferring function, paper guide function, jam removing function, paper sensing function, and main board supporting function.

It is designed for basic attachment, and the duplex feeding takes a side feeding method. Usable papers are A4, letter, and legal size paper.

For removing a jam occurred in a front part, it is designed to open a cassette and a guide.

It is designed to open a rear cover to remove a jam in a rear part.

#### 7) SCF (Second Cassette Feeder)

It is the same method with the main cassette, and the capacity is 250 sheets.

It has a separate driving mechanism. It is designed for a common use with a main cassette.

### 2.2.2.2 Transfer

---

A transfer roller transfers toner on an OPC drum to the paper.

Life span: Print over 50,000 sheets (In 16~27°C)

### 2.2.2.3 Driver Ass'y

---

By driving the motor, the system takes power. It consists of a main motor for feeding fuser and duplex reverse turn.

- Main Motor : DC 24V, Rated RPM : 2170rpm

### 2.2.2.4 Fuser

---

It is consisted of a heat lamp, heat roller, pressure roller, thermistor and thermostat. It sticks the toner on a paper by heat and pressure to complete the printing job.

- Halogen lamp : 750 Watt  $\pm$ 5%

#### 1) Thermostat

When a heat lamp is overheated, a Thermostat cuts off the main power to prevent over-heating.

- Non-Contact type Thermostat

#### 2) Heat roller

The heat roller transfers the heat from the lamp to apply a heat on the paper. The surface of a heat roller is coated with Teflon, so toner does not stick to the surface.

#### 3) Pressure roller

A pressure roller mounted under a heat roller is made of a silicon resin, and the surface also is coated with Teflon. When a paper passes between a heat roller and a pressure roller, toner adheres to the surface of a paper permanently.

#### 4) Items for safety

Protecting device for overheating

- 1st protection device: Hardware cuts off when overheated
- 2nd protection device: Software cuts off when overheated
- 3rd protection device: Thermostat cuts off main power.

Safety device

- A fuser power is cut off when a front cover is opened
- Maintain a temperature of fuser cover's surface under 80°C for user, and attach a caution label at where customer can see easily when customer open a rear cover.

### 2.2.2.5 LSU (Laser Scanner Unit)

---

It is the core part of the LBP which switches from the video data received to the controller to the electrostatic latent image on the OPC drum by controlling laser beam, exposing OPC drum, and turning principle of polygon mirror. The OPC drum is turned with the paper feeding speed. The /HSYNC signal is created when the laser beam from LSU reaches the end of the polygon mirror, and the signal is sent to the controller. The controller detects the /HSYNC signal to adjust the vertical line of the image on paper. In other words, after the /HSYNC signal is detected, the image data is sent to the LSU to adjust the left margin on paper. The one side of the polygon mirror is one line for scanning.



### 2.2.2.6 Print Cartridge

By using the electronic photo process, it creates a visual image. In the print cartridge, the OPC unit and the toner cartridge unit are in a body. The OPC unit has OPC drum and charging roller, and the toner cartridge unit has toner, supply roller, developing roller, and blade (Doctor blade)

- Developing Method : Non-contacting method
- Toner : Non magnetic 1 component pulverized type toner
- The life span of toner : 2,000 or 5,000 pages (LSA Pattern/A4 standard)
- Toner remaining amount detecting sensor : Yes
- OPC Cleaning : Cleaning blade type
- Management of disusable toner : Collect the toner by using Cleaning Blade
- OPC Drum protecting Shutter : No
- Classifying device for toner cartridge : ID is classified by CRUM. except for initial cartridge.

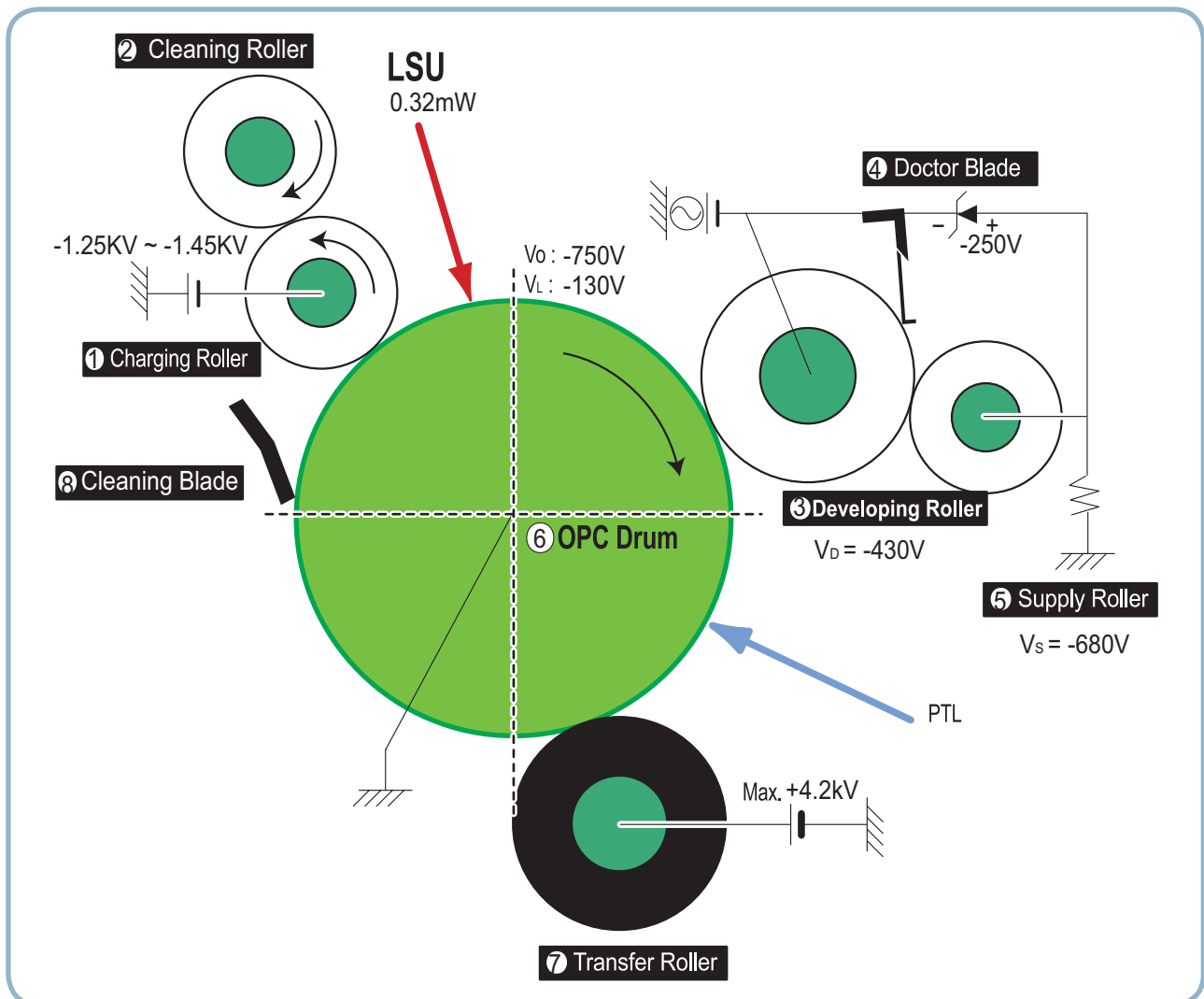

## 2.2.3 Engine H/W Specifications

### 2.2.3.1 Main Board

Main Board is composed of controller part and engine part. It operates following functions by CPU.

- Controller Part
  - Perform the electro-photography
  - Memory control (DDR2 SDRAM, NOR FLASH, Serial FLASH, EEPROM)
  - Handling of signal between each driver and PC Interface
  - Clock generation
- Engine Part
  - Motor control (BLDC, Stepping)
  - ADF Motor Interface(DADF reserved)
  - LSU(2 beam LVDS Type) control
  - Fuser control (On /Off)
  - I/O signal handling (Sensor / Clutch signal)
  - OPE / CIS / MODEM / SCF control
  - CRUM Control
  - FAN Control

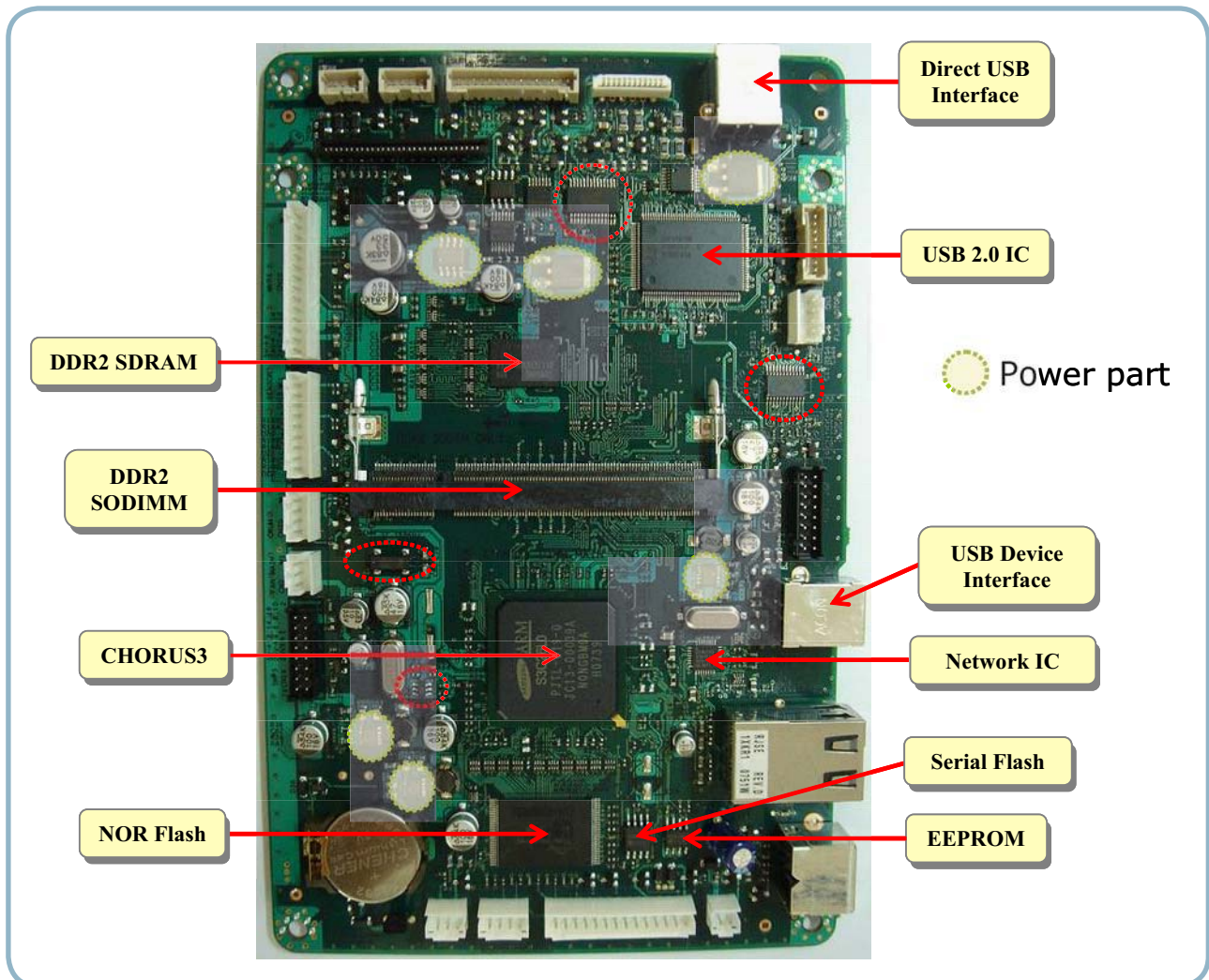

## 2.2.3.1(a) Asic(CHRUS3)

Package	• 412 PBGA (Total pad number : 412[ea])
Voltage	• Core Voltage : 1.0[V] • I/O Pad Voltage: 3.3[V]
CPU Core	• ARM926EJS(16KB I-cache, 16KB D-cache)
Operating Freq.	• 400MHz
DDRC	• DDR 1, 2 Combo • 32 Bits Data Width(Internal), 16 Bits Data Width(External) • 133[MHz] DRAM Interface • 16 to 128[MB] Arrays (Up to 512[MB] totally) • Support 4 AHB Slave Ports for Individual Memory Access • Support 4 Bank DDR1 SDRAM and 4 & 8 Bank DDR2 SDRAM • Support Up to 4 DRAM Ranks(Chip Select Output)
ROMC	• 2 Channel NOR Flash Controller
IOC	• Support 4 Channel External I/O Device, 2 Channel DMA I/O
DMAC	• Contained 3 Channels
HPVC	• Support 32 Bits AHB Master I/F • A4 2400[DPI], A3 1200[DPI] Addressable • 200, 300, 400, 600[DPI] Support, 120[DPI](Vertically 600[DPI]) • Support 4 Channels Single/Dual Beam
UART	• 4 Channels
INTERRUPT	• Support Up to 4 Dedicated External Interrupts • Support 64 Internal Interrupts
TIMER	• 6 System Timers for General Purpose • 1 Watchdog timer • Support RTC
MAC	• 10[Mbps]/100[Mbps] • Full IEEE 802.3, 802,3u compatibility
PPI	• IEEE1284 Compliant Parallel Port Interface
SPI	• 1 Slave Select
USB	• USB 2.0, 1 Channel (Host & Device Selectable) • Support 1,5/12/480[Mbps]
GEU	• Graphic Execution Unit
RSH	• Fully Hardware Rotator / Scaler / Halftoner support
SCAN I/F	• 1200[DPI] CCD Sensor I/F • 1/2 Channels AFE Input(1 Dedicated, 1 Muxed) • Sensor MCLK Half Clock Control
LSU	• 2 Channels for Dual Beam • Test Pattern Generation • FSYNC Generation
JPEG	• Encoder 1 Channel, Decoder 1 Channel

JBIG	• 2 JBIG Compressor & 4 JBIG De-compressor
Codec	• 5 Halftone Compression/Decompression Unit • Support 32 Bits AHB Master I/F • MH/MR/MMR Encoder 1 Channel • MH/MR/MMR Decoder 1 Channel
HCT	• 1 Channel Encoder, 1 Channel Decoder
Engine Controller	• PWM: 12 Channels(Dedicated 8 Channels, Muxed 4 Channels) • Step Motor Controller
I2C Controller	• 2 Channels • I2C bus(SM bus) Slave Device Support (I2C Version 2.1)
PLL	• 3 PLLs (for MAIN / PVC / DDR)
DAC	• 1 Channel, 10 Bits, 2[MSPS]
ADC	• 8 Channel, 10 Bits, 500[KSPS]

### 2.2.3.1(b) Memory

- Program Memory : This model uses NOR Flash as a Program memory which stores System Program and can be updated via USB Interface.
  - Capacity : 16 MB
  - Max. Access Time : 90ns
- Working Memory : This model uses DDR2 SDRAM which is used as Swath Buffer in Printing, Scan Buffer in Scanning, ECM Buffer in FAX receiving, and System Working Memory Area.
  - Capacity: 128MB or 256MB optional Memories are available.
  - Type : DDR2 SDRAM 667MHz , 16bit

### 2.2.3.1(C) Interface

The system supports the following standard interfaces:

- High Speed USB 2.0
  - Device
  - Direct USB(SCX-4828FN only)
- Ethernet 10/100 Base TX wired LAN

SCX-4824FN & SCX-4828FN supports an internal Network Interface that can be installed pre-configured on the video controller board at the factory. This supports all of the major Network Operating Systems such as the TCP/IP, etc. Details of the network specification will be provided separately.

### 2.2.3.2 SMPS & HVPS board

The SMPS supplies DC Power to the System.

It takes 110V/220V and outputs the +5V, +24V to supply the power to the main board and all other boards. The HVPS board creates the high voltage of THV/MHV/Supply/Dev and supplies it to the developer part for making best condition to display the image. The HVPS part takes the 24V and outputs the high voltage for THV/MHV/BIAS, and the outputted high voltage is supplied to the toner, OPC cartridge, and transfer roller

#### 2.2.3.2(a) HVPS (High Voltage Power Supply)

- Transfer High Voltage (THV+)
  - Input Voltage: 24 V DC  $\pm$  15%
  - Output Voltage: MAX +5.0KV(Duty Variable)
  - Line Regulation : under $\pm$ 3% (fluctuation input 21.6V ~ 27.6V)
  - Output Voltage Rising Time 50ms Max
  - Output Voltage Falling Time : 100 ms Max
  - Fluctuating transfer voltage with environmental various : 0 V~ 5 KV
  - Environment Recognition Control Method : The THV-PWM ACTIVE is transfer active signal. It detects the resistance by recognizing the voltage value, F/B, while permits the environmental recognition voltage.
  - Output Voltage Control Method : Transfer Output Voltage is outputted and controlled by changing Duty of THVPWM Signal.
- Charge Voltage (MHV)
  - Input Voltage : 24 V DC  $\pm$  15%
  - Output Voltage : -1.2KV ~ -1.8KV DC  $\pm$  3%
  - Output Voltage Rising Time : 50 ms Max
  - Output Voltage Falling Time : 50 ms Max
  - Output Control Signal(MHV-PWM) : CPU is HV output when PWM is Low
- Cleaning Voltage (THV-)
  - -1.2KV  $\pm$  15%
  - The (+) Transfer Voltage is not outputted because the THV PWM is controlled with high.
  - The (-) Transfer Voltage is outputted because the THV-Enable Signal is controlled with low
  - The output fluctuation range is big because there is no Feedback control & connection Resistor.
- Developing Voltage (DEV)
  - Input Voltage : 24 V DC  $\pm$  15%
  - Output Voltage: -200V ~ -600V DC  $\pm$  3%
  - Output Voltage Fluctuation Method : PWM Control
  - Line Regulation : under $\pm$ 3% (fluctuation input 21.6V ~ 27.6V)
  - Load Regulation : Under  $\pm$ 3%
  - Output Voltage Rising Time : 50 ms Max
  - Output Voltage Falling Time : 50 ms Max
  - Output Control Signal (BIAS-PWM) : the CPU output is HV output when PWM is low.
- Supply
  - Output Voltage : -300V ~ -800V DC  $\pm$  5% (ZENER using, DEV )
  - Line Regulation : under $\pm$ 3% (fluctuation input 21.6V ~ 27.6V)
  - Load Regulation : Under  $\pm$ 3%
  - Output Voltage Rising Time : 50 ms Max
  - Output Voltage Falling Time : 50 ms Max
  - Output Control Signal (BIAS-PWM) : the CPU is HV output when PWM is low

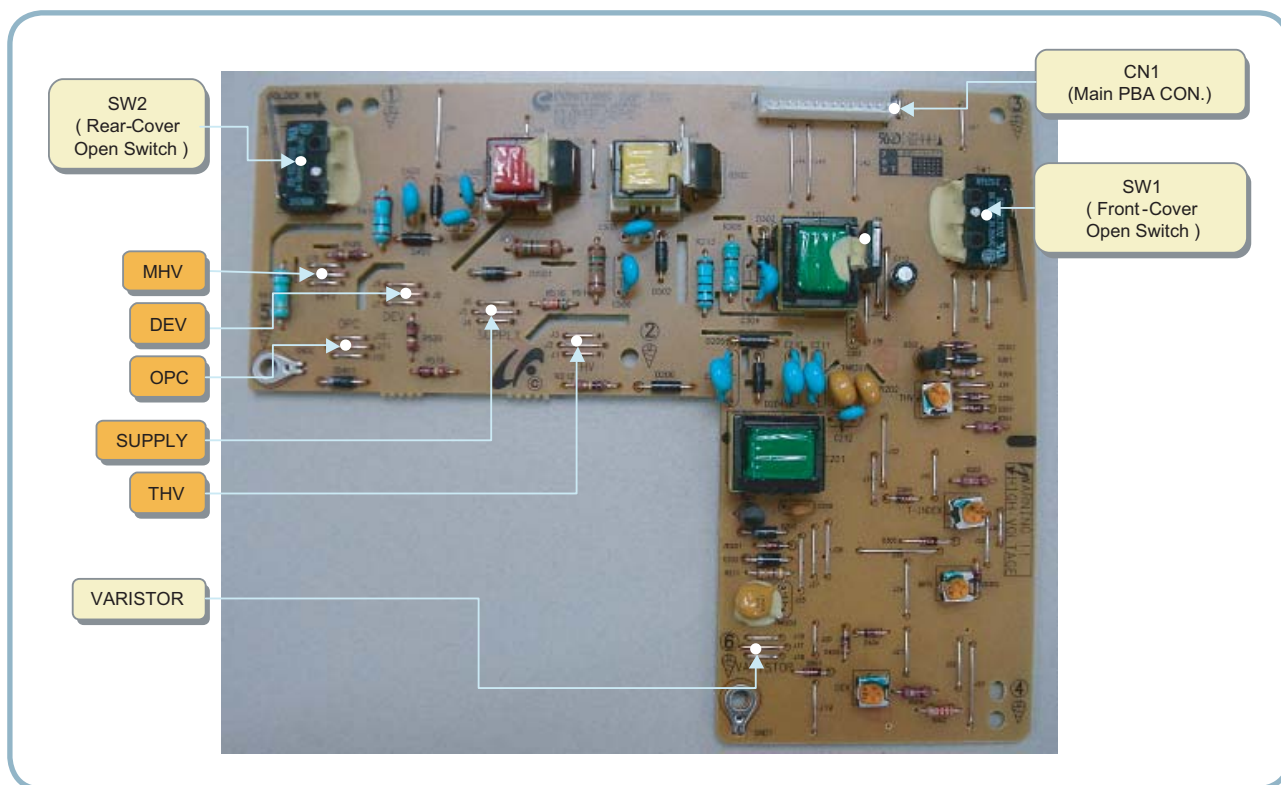

### 2.2.3.2(b) SMPS (Switching Mode Power Supply)

It is the power source of entire system. It is assembled by an independent module, so it is possible to use for common use. It is mounted at the side of the set. It is consisted of the SMPS part, which supplies the DC power for driving the system, and the AC heater control part, which supplies the power to fuser. SMPS has two output channels. Which are +5V and +24V.

- AC Input

- Input Rated Voltage: AC 110V ~ 127V / AC 220V ~ 240V
- Input Voltage fluctuating range : AC 90V ~ 135V / AC 180V ~ 270V
- Rated Frequency : 50/60 Hz
- Frequency Fluctuating range : 47 ~ 63 Hz
- Input Current : Under 4.0Arms / 2.0Arms (But, the status when lamp is off or rated voltage is inputted/ outputted )

• Rated Output Power

NO	ITEM	CH1	CH2	Remark
1	CHANNEL NAME	+5V	+24.0V	
2	CONNECTOR PIN	CON 4 5V PIN: 11,13,15 GND PIN: 12,14,16	CON 4 24V PIN:3,5,7,9, GND PIN:4,6,8,10	CON 4 24VS PIN: 2
3	Rated Output	+5.1V±2% (5.0~5.2V)	+24V -10%/+10% (21.6~26.4V)	
4	Nor. Output Current	1.6A	1.8 A	
5	Max. Output Current	2.0 A	2.5 A	
6	RIPPLE & NOISE Voltage	Under100mVp-p	Under 500mVp-p	
7	Normal output	8.16W	43.2W	
8	Maximum output	10.2W	60.0W	
9	Protection for loading shortage and overflowing current	Shut down(2.5~5.0A) or Fuse Protection (Under LPS spec)	Shut down(2.8A~5.5A)or Voltage Drop(trip-10%)	

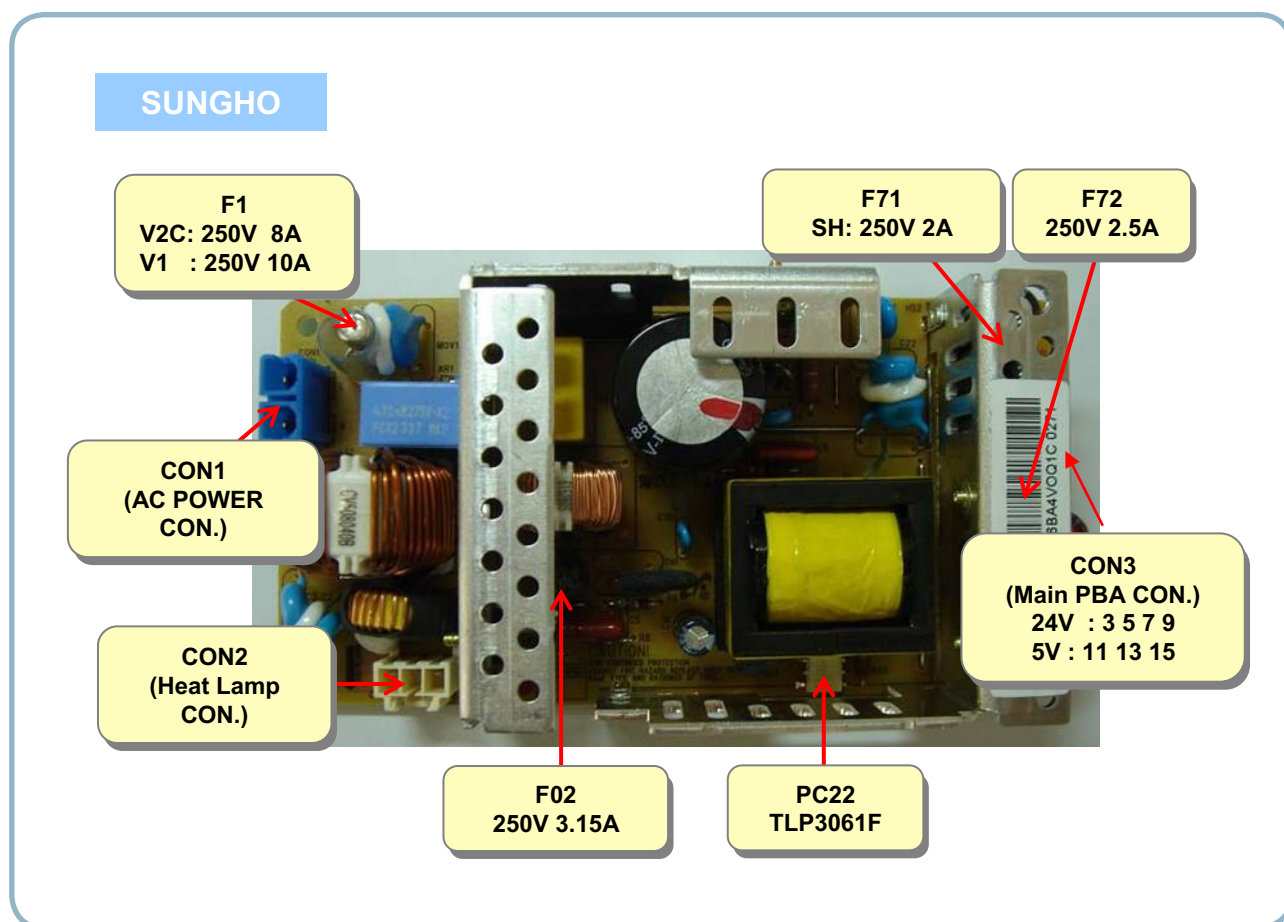

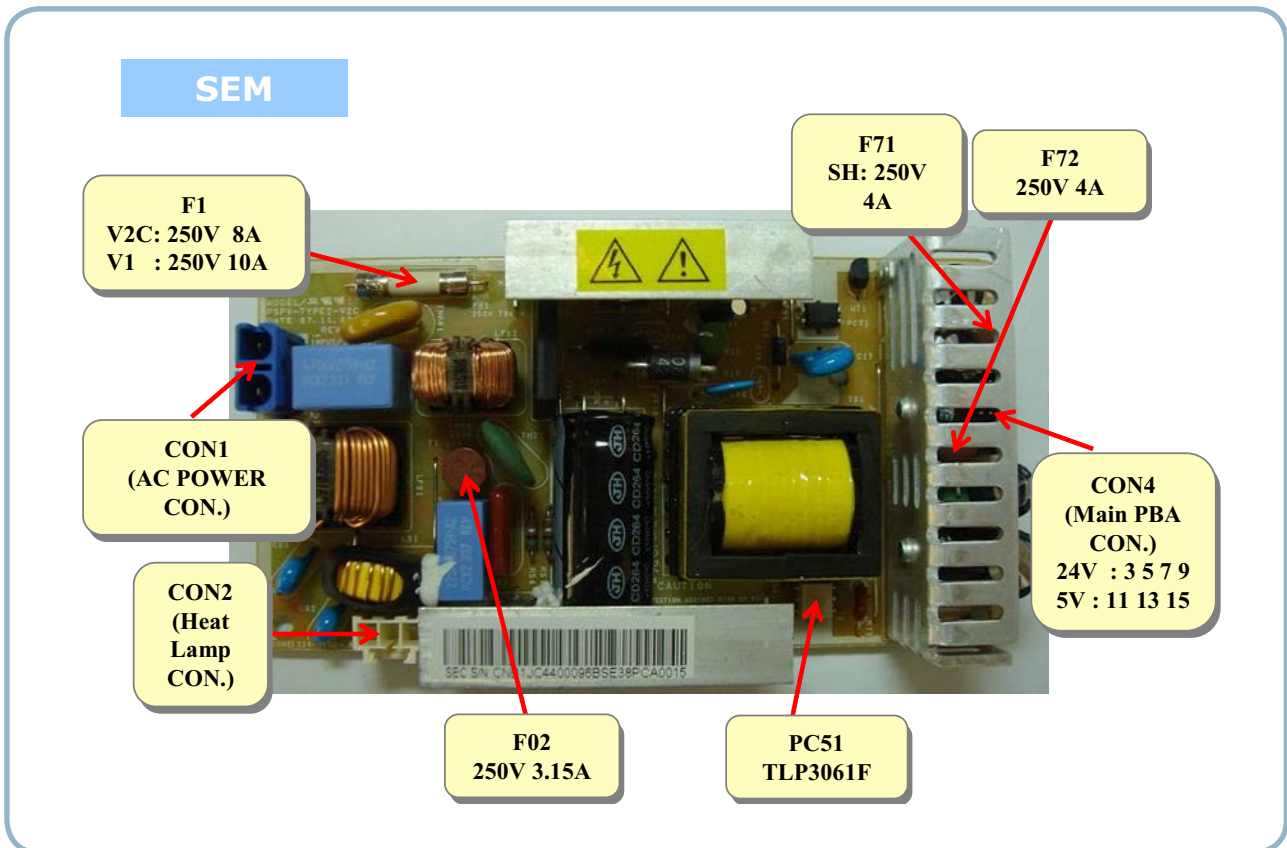

### 2.2.3.2(c) FUSER AC POWER CONTROL

Fuser(HEAT LAMP) gets heat from AC power. The VA power controls the switch with the Triac, a semiconductor switch. The 'ON/OFF control' is operated when the gate of the Triac is turned on/off by Phototriac (insulating part). In other words, the AC control part is passive circuit, so it turns the heater on/off with taking signal from engine control part.

When the 'HEATER ON' signal is turned on at engine, the LED of PC51 (Photo Triac) takes the voltage and flashes. From the flashing light, the Triac part (light receiving part) takes the voltage, and the voltage is supplied to the gate of Triac and flows into the Triac. As a result, the AC current flows in the heat lamp, and heat is occurred. On the other hand, when the signal is off, the PC51 is off, the voltage is cut off at the gate of Triac, the Triac becomes off, and then the heat lamp is turned off.

- Triac (Q51) feature : 16A-LV model / 12A-HV model, 600V SWITCHING
- Phototriac Coupler (PC51)
  - Turn On If Current : 15mA~50mA(Design: 16mA)
  - High Repetive Peak Off State Voltage : Min 600V



### 2.2.3.3 Fax

Implemented by based on Conexant DAA (Data Access Arrangement) Solution, and is roughly composed of two kinds Chip Solution

- CX86710 (SFX336): Existing Modem Chip which adds SSD (System Side Device) for interfacing between LSD and DIB of FM336Plus Core
- CX20493 (LSD) : LIU (Line Interface Unit) Chip which is controlled by SSD and satisfies each PSTN Requirements by modulating internal Configuration with connecting Tel Line

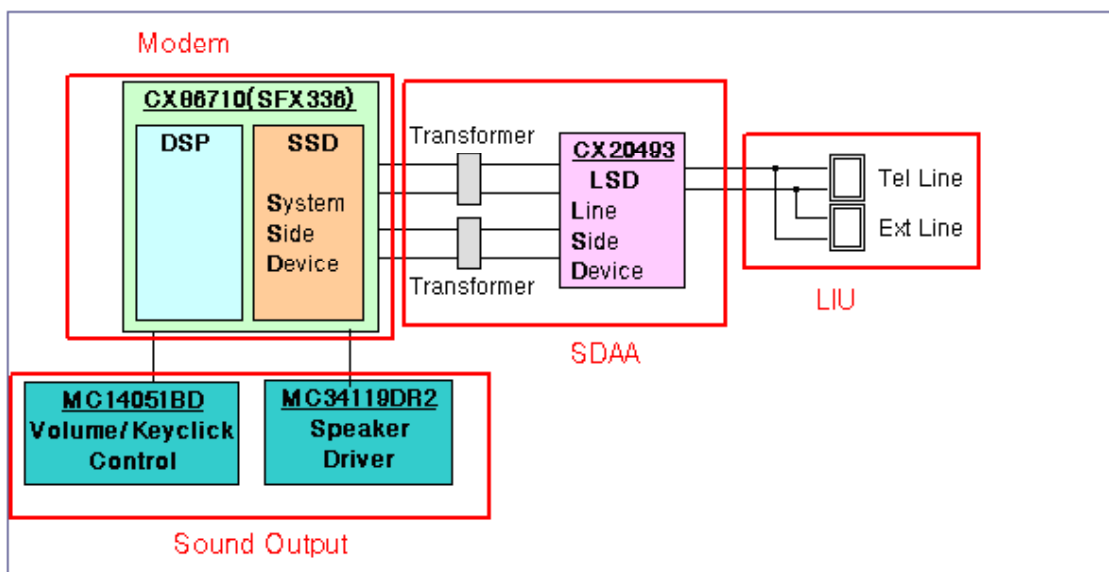

### 2.2.3.4 Scan

1) Pictorial signal input part: output signal of CIS passes through MP Cap change to ADC at HT82V26, and defined signal between HT82V26 and CHORUS3 processes the Image signal. When AFE accept each pixel, SHA (Sample and Hold Amplifier) technique which samples arm-level once is used on each pixel by CIS signal.

2) Pictorial image processing part: read CIS Pixel data in terms of 1200dpi Line and process Error Diffusion Algorithm(text,Mixed mode), 1200 dither(photo mode), and then store Data at Scan Buffer on PC Scan mode without algorithm.

On every mode Shading Correction and Gamma Correction are executed ahead, then processing is executed later.

\* Scan Image Control Specification

- ① Scan Line Time : 1.5msec/ch
- ② Scan Resolution : Max. 1200DPI
- ③ Scan Width : 216mm
- ④ main function
  - Internal 12bit ADC
  - White Shading Correction
  - Gamma Correction
  - CIS Interface

3) CIS Operating Part : CIS Image sensor use +5V

- CIS Maximum Operating Frequency : 5MHz
- CIS Line time : 1.5 msec/ch
- White Data output Voltage :  $0.7V \pm 0.5V$  (Mono Copy, 1.50ms/line)

## 2.2.3.5 Engine F/W

### 2.2.3.5(a) Control Algorithm

#### • Feeding

If feeding from a cassette, the drive of the pickup roller is controlled by controlling the solenoid. The on/off of the solenoid is controlled by controlling the general output port or the external output port. If feeding from a manual feeder, decide to insert the paper according to the operation of the Regi sensor, and by driving the main motor, insert the paper in front of the feed sensor. While paper moves, occurrence of Jam is judged as below.

Item	Description
JAM 0	<ul style="list-style-type: none"> <li>- After picking up, paper cannot be entered due to paper is not fed.</li> <li>- After picking up, paper entered but it cannot reach to the feed sensor in certain time due to slip, etc.</li> <li>- After picking up, if the feed sensor is not on, re-pick up. After re-picking up, if the feed sensor is not on after certain time, it is JAM 0.</li> <li>* It is a status that the leading edge of the paper doesn't pass the feed sensor.</li> <li>- Even though the paper reaches to the feed sensor, the feed sensor doesn't be ON.</li> <li>* It is a status that the leading edge of the paper already passes the feed sensor.</li> </ul>
JAM 1	<ul style="list-style-type: none"> <li>- After the leading edge of the paper passes the feed sensor, the trailing edge of the paper cannot pass the feed sensor after a certain time. (The feed sensor cannot be OFF)</li> <li>- After the leading edge of the paper passes the feed sensor, the paper cannot reach the exit sensor after certain time. (The exit sensor cannot be ON)</li> <li>* The paper exists between the feed sensor and the exit sensor.</li> </ul>
JAM 2	<ul style="list-style-type: none"> <li>- After the trailing edge of the paper passes the feed sensor, the paper cannot pass the exit sensor after certain time.</li> </ul>
DUPLEX JAM 1	<ul style="list-style-type: none"> <li>- After the trailing edge of the paper passes the exit sensor, the leading edge of the paper cannot reach the Duplex Jam Sensor after certain time.</li> </ul>
DUPLEX JAM 0	<ul style="list-style-type: none"> <li>- After the leading edge of the paper passes the Regi sensor, the leading edge of the paper cannot reach the feed sensor after certain time.</li> </ul>

### 2.2.3.5(b) Driver

By gearing, the main motor drives the rollers such as feeding roller, developing roller, fuser roller, and exiting roller. The BLDC motor is controlled for the such acceleration section and steady section. The BLDC main motor is operated by the BLDC clock and the enable signal.

### 2.2.3.5(c) Transfer

The charging voltage, developing voltage and the transfer voltage are controlled by PWM (Pulse Width Modulation). The each output voltage is changeable due to the PWM duty. The transfer voltage admitted when the paper passes the transfer roller is decided by environment recognition. The resistance value of the transfer roller is changed due to the surrounding environment or the environment of the set, and the voltage value, which changes due to the environments, is changed through AD converter. The voltage value for impressing to the transfer roller is decided by the changed value. Each voltage value is controlled according to 3.3.4.2 Timing Chart.

### 2.2.3.5(d) Fusing

The temperature change of the heat roller's surface is changed to the resistance value through the thermistor.

By converting the voltage value, which impressed to the resistance, to the digital value through the AD converter, the temperature is decided. The AC power is controller by comparing the target temperature to the value from the thermistor. If the value from the thermistor is out of controlling range while controlling the fusing, the error stated in the below table occurs.

#### • Lamp Method

Error	Description
OPEN HEAT ERROR	- When warming up, it has been lower than 90 over 20 seconds
LOW HEAT ERROR	- Standby has been lower than the Standby Reference Temperature -20 over 10 seconds. - Printing has been lower than the Printing Reference Temperature -20 over 10 seconds. - When WarmUp End Process, it have been lower than the WarmUp Reference Temperature -10 over 10 seconds.
OVER HEAT ERROR	- It has been higher than 220 over 20 seconds - It has been higher than 230 over 3 seconds - It has been higher than the Standby Reference Temperature +10 over 180 seconds.

=>This can be changed in the future.

### 2.2.3.5(e) LSU

The LSU is consisted of the LD (Laser Diode) and the polygon motor control. When the printing signal occurs, it turns on the LD and drives the polygon motor. When the detector detects the beam, Hsync occurs. When the polygon motor speed becomes strady, Lready occurs. If two conditions are satisfied, the status are not satisfied, the error shown in below occurs.

Error	Description
Polygon Motor Error	Whenthe polygon motor speed doesn t become steady
Hsync Error	The polygon motor speed is steady but the Hsync is not generated

## 2.2.4 S/W Descriptions

### 2.2.4.1 Overview

The software of SCX-482x series system is constructed with

- 1) Host Software part that the application software operated in Window and Web Environment, and
- 2) Firmware parts that is a Embedded software controls printing job.

### 2.2.4.2 Architecture

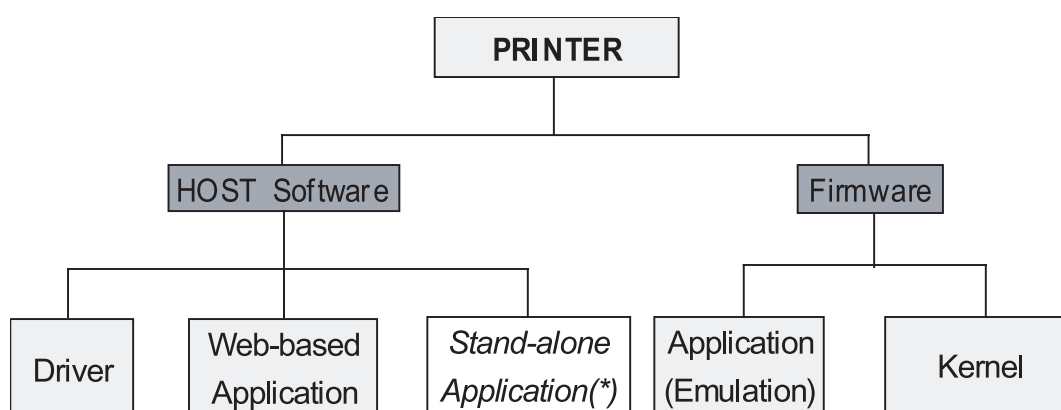

☞ (\*) is job for common S/W team

#### Host Software is made up of

1. Graphic User Interface that offers the various editing functions to user in Host,
2. Driver that translates the received document to a Printing Command language which printer can understand and transfers data to spooler,
3. Stand-alone Application that offers the various printing application, PSU(Printer Settings Utility), Printer Status Monitor, Network Management in Window system,
4. Web-based-Application that offers the same functions as Stand-alone Application and RDC(Remote Diagnosis Control) in Web environment.

#### Firmware is made up of

1. Application (Emulation) that is a interpreter translate data received from Host to a printing language (PCL, PS, GDI(only SCX-4824FN), etc.) to be able to make the user to take same output as originally one what composed in Host.
2. Kernel that control and management the whole procedure include of Control flow and Printing Job before transfer to Engine system.

### 2.2.4.3 Data and Control Flow

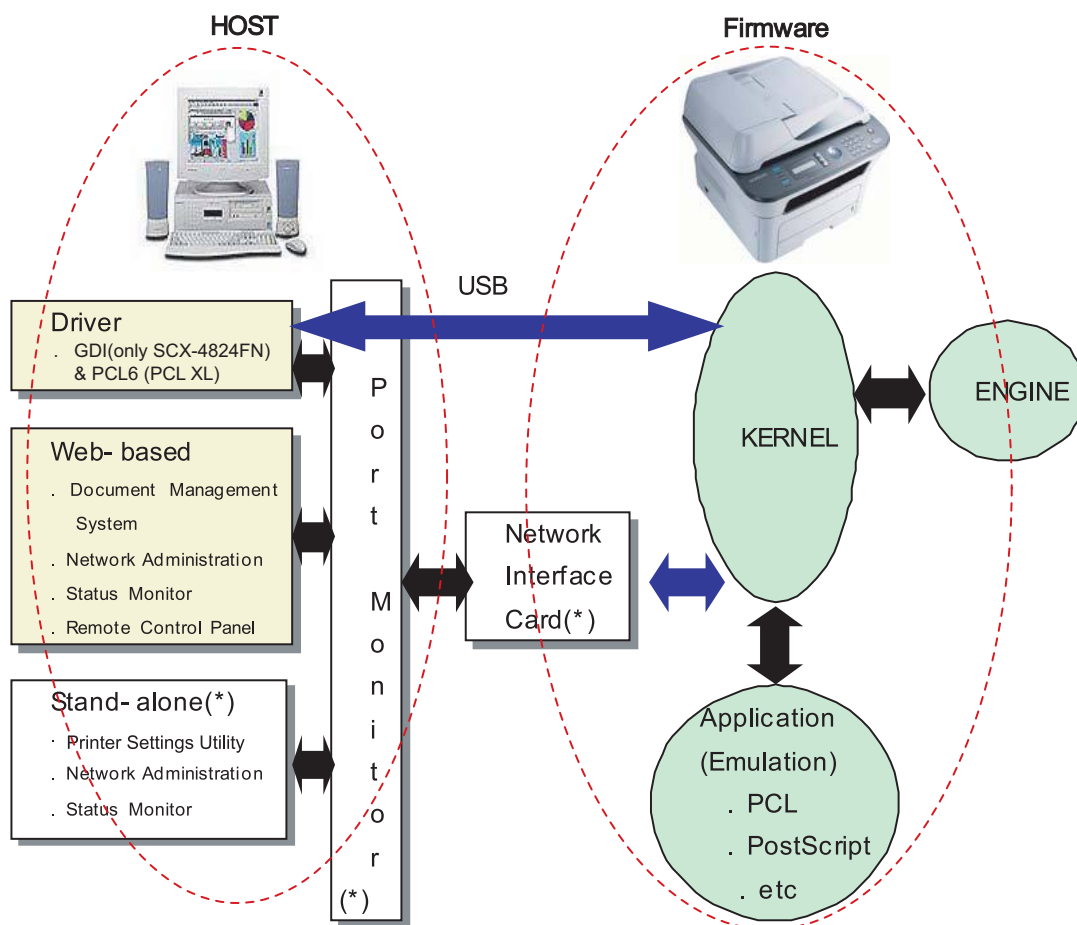

Note: (\*) is role of N/W I/F

The above Block Diagram is explained that:

Host Side is made up of

1. Driver that is Windows application software translate printed data to one of printer language and create spooler file.
2. Web-based Application that offer a various printer additional functions, management of printing job, printer administration, Status monitor to monitoring the printer status by real time in Web, independent environment on OS.
3. Stand-alone Application that is a similar Window software as same as above 2,
4. Port Monitor that manages the network communication between spooler and Network Interface Card, or various additional application and Network Interface Card,(this is, at first, make communication logical port, manage the data, transfer them from spooler to network port, and offer the result of printing).

**Firmware Side is made up of**

1. Network Interface Card is that relay the communication between Host and kernel using various network protocol.
2. Kernel is that manages the flow control of emulation procedure, receiving data from Host or Network card and printing with engine & rendering job,
3. Emulation is that interprets the various output data from selected emulation,
4. Engine is that prints rendered bit-map data to paper with required size and type by Kernel.

And then, for Job Spooling function for Multi-User, Multi-Printing that is occurred in Network printing and various additional printing functions, this Kernel use max. 10 Queuing systems in a memory.

**In Printing, the two procedures are****(1) Case of using USB Port**

- After user start to print the wanted document to PCL string or compressed GDI bit-map data, Driver translate the all graphic data of it and send data to host spooler. And then the spooler sends the data stream to the printer via USB port.
- Kernel receives this data from Host, and then select emulation fit to data and start selected one. After emulation job end, Kernel sends the output bit-map data to Engine using Printer Video Controller (by clock type for LSU).
- Engine print the received data to required paper with the sequential developing process.

**(2) Case of using Network Interface Card**

- After user start to print the wanted document to PCL string or compressed GDI bit-map data, Driver translate the all graphic data of it and send data to host spooler.
- If so, Port monitor managing network port receives data from spooler and sends a data stream to the Network Interface Card.
- Network interface card receives it and send to Kernel part.
- Kernel receives this data from Host, and then select emulation fit to data and start selected one. After emulation job end, Kernel sends the output bit-map data to Engine using Printer Video Controller (by clock type for LSU).
- Engine print the received data to required paper with the sequential developing process.

**The additional printing function are realized in**

- (1) Web environment
- (2) Window environment.

On addition, Kernel informs a status of printing status and printer status to user made printing job with the Status Monitor.

## 3. Disassembly and Reassembly

### 3.1 General Precautions on Disassembly

When you disassemble and reassemble components, you must use extreme caution. The close proximity of cables to moving parts makes proper routing a must.

If components are removed, any cables disturbed by the procedure must be restored as close as possible to their original positions. Before removing any component from the machine, note the cable routing that will be affected.

**Whenever servicing the machine, you must perform as follows:**

1. Check to verify that documents are not stored in memory.
2. Be sure to remove the toner cartridge before you disassemble parts.
3. Unplug the power cord.
4. Use a flat and clean surface.
5. Replace only with authorized components.
6. Do not force plastic-material components.
7. Make sure all components are in their proper position.

#### Releasing Plastic Latches

Many of the parts are held in place with plastic latches. The latches break easily; release them carefully.

To remove such parts, press the hook end of the latch away from the part to which it is latched.

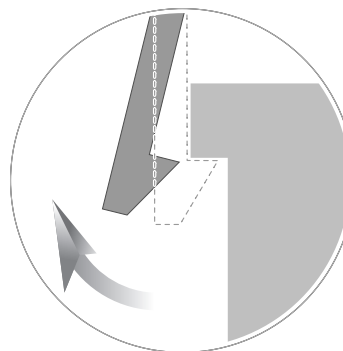



### 3.1.1 Screws used in the printer

SEC_CODE	Location	Description	Qty
6002-000440	Duplex Unit	SCREW-TAPPING;PWH,+,-,2,M3,L8,ZPC(BLK),SWRCH18A,-	1
6003-000196		SCREW-TAPTITE;PWH,+ ,B,M3,L10,NI PLT,SWRCH18A	3
6003-000282	CARTRIDGE-TONER	SCREW-TAPTITE;BH,+,-,B,M3,L8,ZPC(BLK),SWRCH18A,-	10
6003-000196	ELA HOU-SCAN_HIGH	SCREW-TAPTITE;PWH,+ ,B,M3,L10,NI PLT,SWRCH18A	10
6003-000269	ELA HOU-ADF MOTOR	SCREW-TAPTITE;BH,+,-,S,M3,L6,ZPC(WHT),SWRCH18A,-	3
6003-000196	ELA HOU-ADF LOWER	SCREW-TAPTITE;PWH,+ ,B,M3,L10,NI PLT,SWRCH18A	6
6003-000196	MEA-COVER PLATEN	SCREW-TAPTITE;PWH,+ ,B,M3,L10,NI PLT,SWRCH18A	6
6003-000196	ELA HOU-OPE	SCREW-TAPTITE;PWH,+ ,B,M3,L10,NI PLT,SWRCH18A	4
6003-000196	ELA HOU-PLATEN_HIGH	SCREW-TAPTITE;PWH,+ ,B,M3,L10,NI PLT,SWRCH18A	4
6003-000196	ELA HOU-SCAN LOWER_H	SCREW-TAPTITE;PWH,+ ,B,M3,L10,NI PLT,SWRCH18A	9
6003-000196	ELA UNIT-STANDARD SCAN	SCREW-TAPTITE;PWH,+ ,B,M3,L10,NI PLT,SWRCH18A	3
6003-000269	ELA UNIT-SCAN DRIVE	SCREW-TAPTITE;BH,+,-,S,M3,L6,ZPC(WHT),SWRCH18A,-	2
6002-000440	ELA HOU-FRAME	SCREW-TAPPING;PWH,+,-,2,M3,L8,ZPC(BLK),SWRCH18A,-	13
6003-000196		SCREW-TAPTITE;PWH,+ ,B,M3,L10,NI PLT,SWRCH18A	64
6003-000301		SCREW-TAPTITE;BH,+,-,S,M4,L6,ZPC(WHT),SWRCH18A,-	1
6006-001078		SCREW-TAPTITE;PH,+ ,WSP,B,M3,L10,ZPC(WHT), SWRCH18A,-	1
6003-000269	ELA UNIT-DRIVE	SCREW-TAPTITE;BH,+,-,S,M3,L6,ZPC(WHT),SWRCH18A,-	11
6003-000196	ELA UNIT-FUSER	SCREW-TAPTITE;PWH,+ ,B,M3,L10,NI PLT,SWRCH18A	3
6003-000282		SCREW-TAPTITE;BH,+,-,B,M3,L8,ZPC(BLK),SWRCH18A,-	4
6003-000282	MEA-COVER FRONT	SCREW-TAPTITE;BH,+,-,B,M3,L8,ZPC(BLK),SWRCH18A,-	1
6003-000196	ELA HOU-MAIN LINE	SCREW-TAPTITE;PWH,+ ,B,M3,L10,NI PLT,SWRCH18A	14
6003-001256		SCREW-TAPTITE;BH,+ ,B,M4,L10,NI PLT,SWRCH18A	4
6003-000282	ELA UNIT-LSU	SCREW-TAPTITE;BH,+,-,B,M3,L8,ZPC(BLK),SWRCH18A,-	10
6003-000282	ELA UNIT-LSU LD	SCREW-TAPTITE;BH,+,-,B,M3,L8,ZPC(BLK),SWRCH18A,-	2
6003-000196	MEA UNIT-CASSETTE	SCREW-TAPTITE;PWH,+ ,B,M3,L10,NI PLT,SWRCH18A	2
6003-000261		SCREW-TAPTITE;BH,+,-,B,M3,L6,ZPC(WHT),SWRCH18A,-	1
6003-000264		SCREW-TAPTITE;PWH,+,-,B,M3,L6,ZPC(WHT),SWRCH18A,-	1

## 3.2 General Disassembly

### 3.2.1 Front Cover

1. Open the front cover after take out the cassette.



2. Separate the front cover from the lock the frame by pulling the front cover to the direction of arrow.

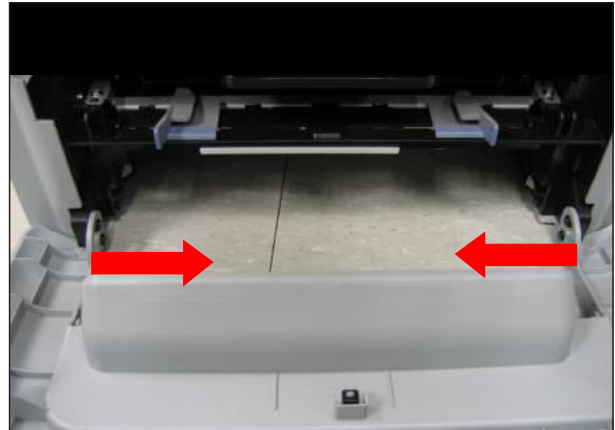

### 3.2.2 Rear Cover

1. Remove the Duplex unit.

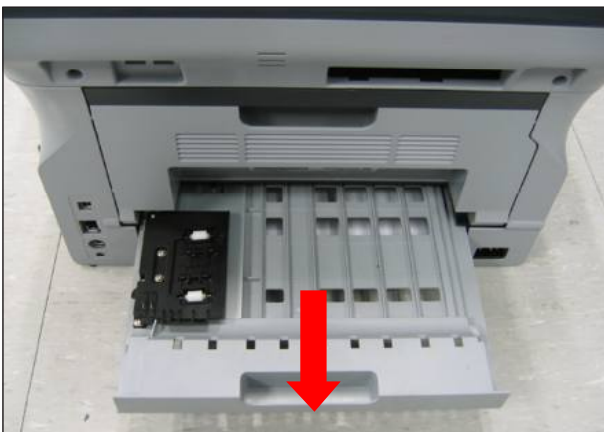

2. Open the rear cover. And separate the rear cover from the locking by pulling the rear cover to the direction of arrow.

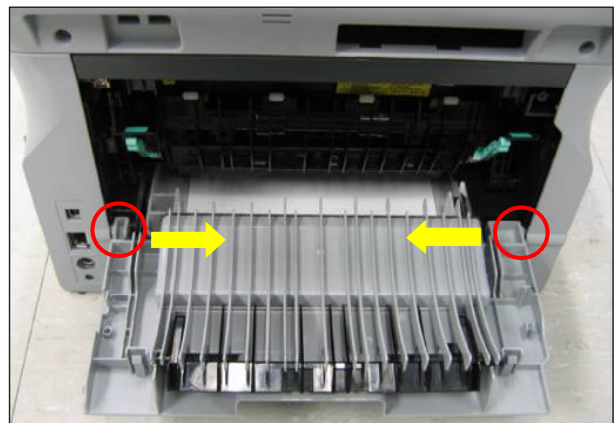

### 3.2.3 Right/Left Cover

1. Remove the one screw. And pull and release the right cover somewhat.

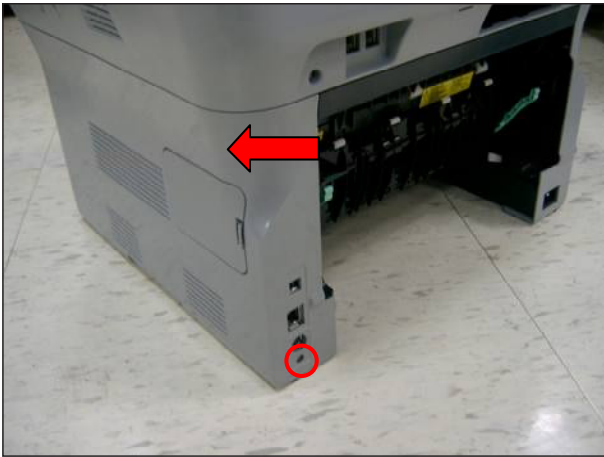

3. Pull the left cover to the direction of arrow and release it.

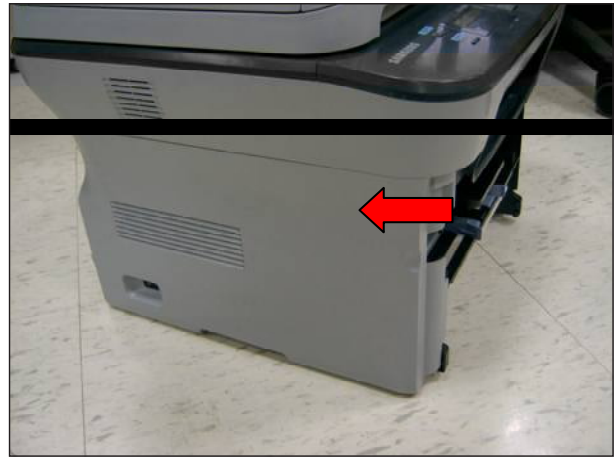

2. Release the right cover after unplug the 1 connector from Main PBA.

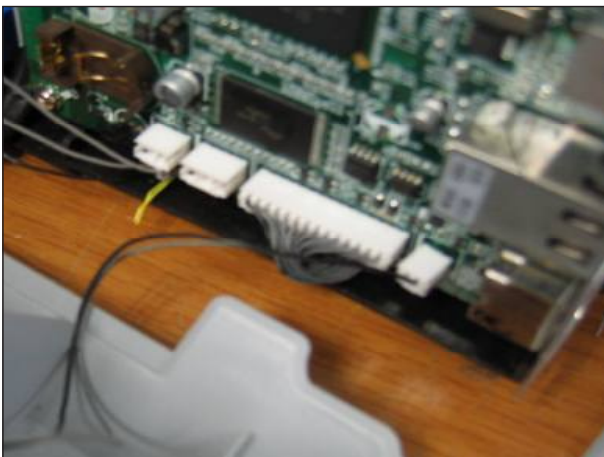

### 3.2.4 Scan and ADF Assy

1. Remove the 2 screws after remove the right cover.



2. Remove the one screw and connected harness from Main board. And lift the Scan Assy to the direction of arrow.



#### 3.2.4.1 ADF Unit

1. Unplug the harness after remove the cap harness as shown below.



2. Lift up and release the ADF Assy.

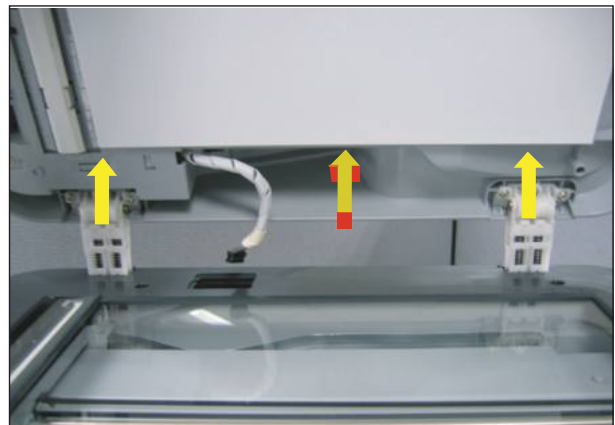

### 3.2.4.2 Stacker TX

1. Remove the 2 screws from the bottom of ADF Assy.

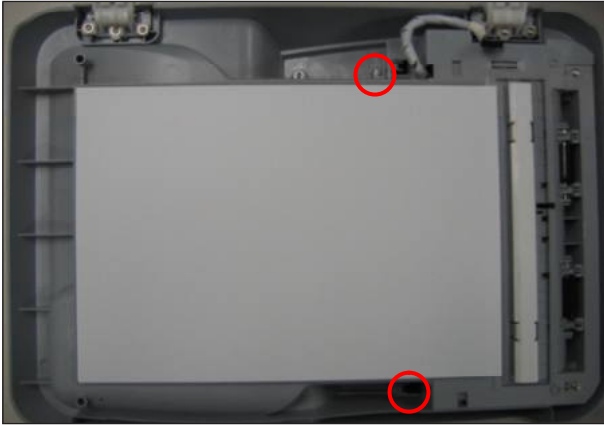

2. Lift up and release the Stacker TX

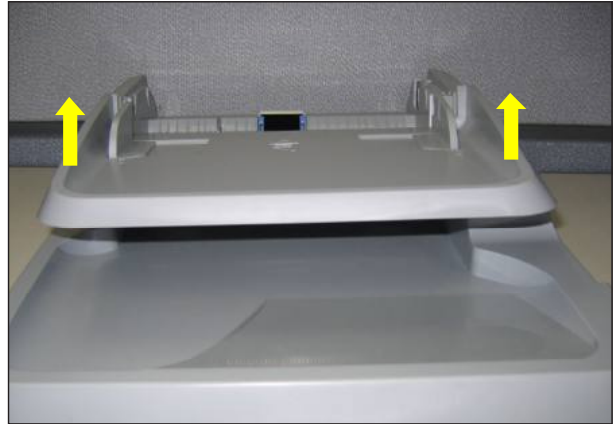

### 3.2.4.3 ADF Engine unit

1. Open the ADF cover and remove it. And remove the pick-up roller by following below sequence.

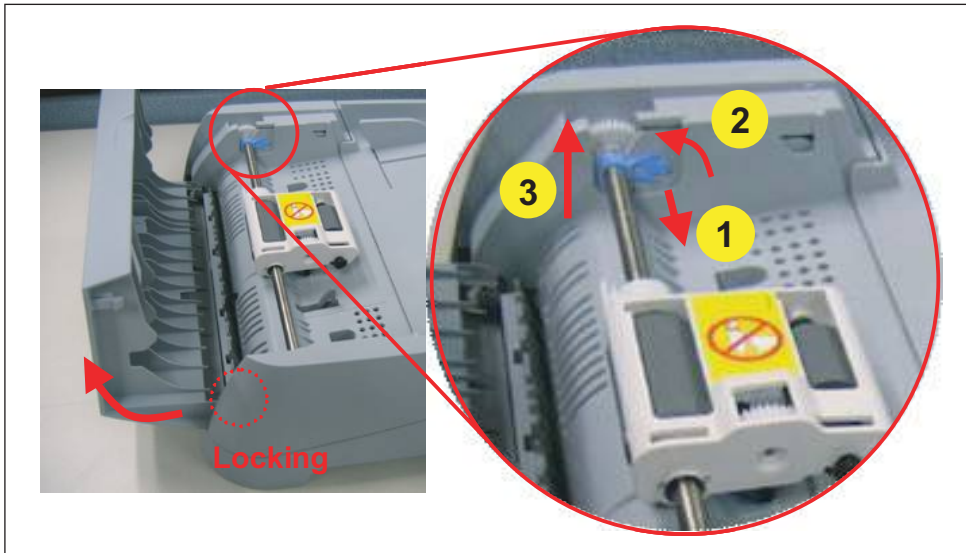

2. Remove the ADF engine unit after remove the 2 screws from the bottom of SET.



3. Remove the 2 screws of the ADF cover upper. And then lift it up.

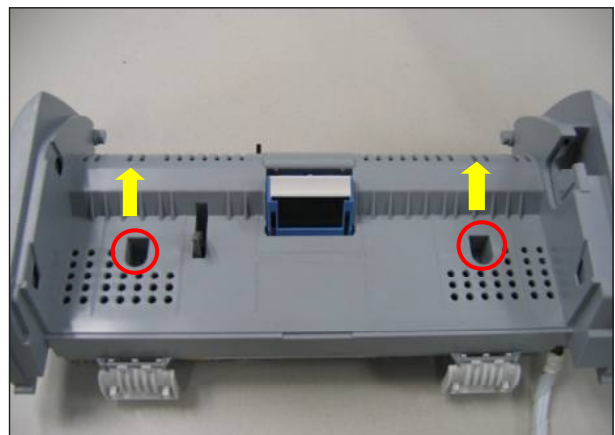

### 3.2.4.4 OPE Unit

1. Pull up the OPE unit.

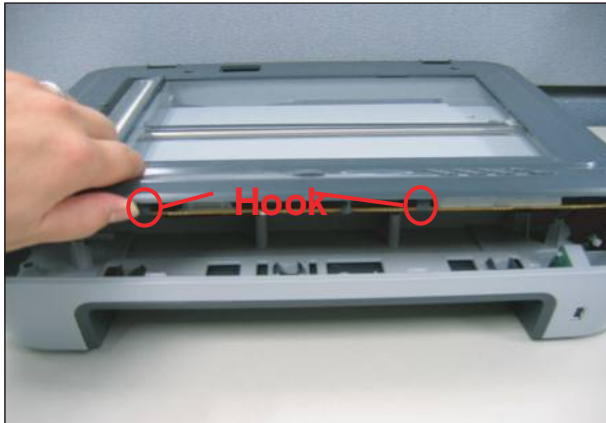

2. Remove the 2 connector and release the OPE unit.



### 3.2.4.5 CIS Unit

1. Remove the 4 screws of the Scan upper.

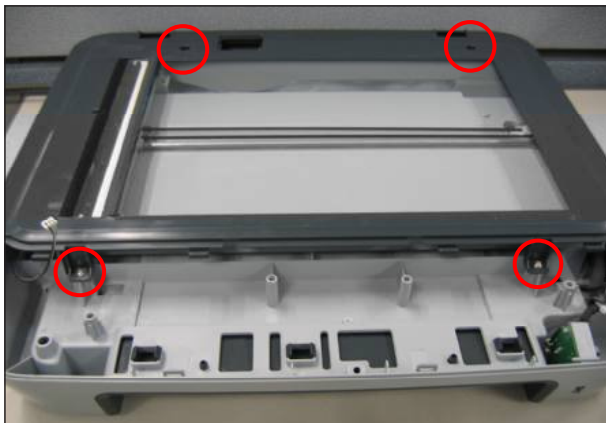

2. Remove the 4 screw and 1 CIS cable. And release the CIS unit.

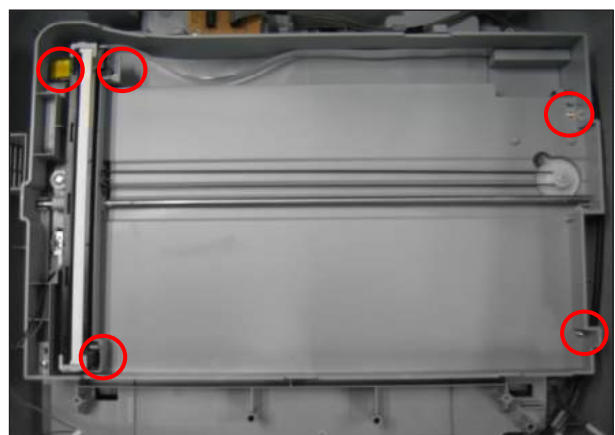

### 3.2.5 Middle Cover

1. Remove the 2 screws as shown below.

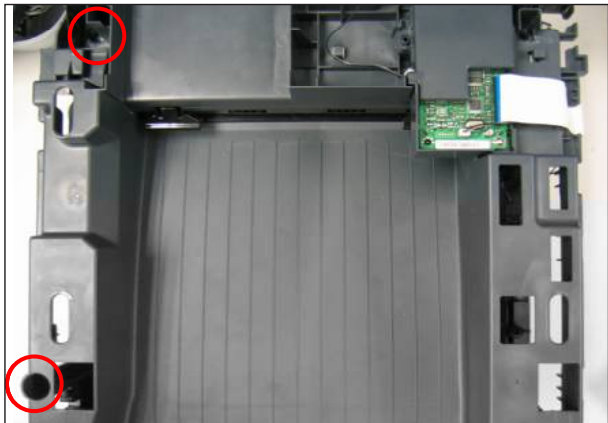

2. Remove the 2 screws from the front and rear of the SET. Unplug the harness connected to the main board. And lift the middle cover up.

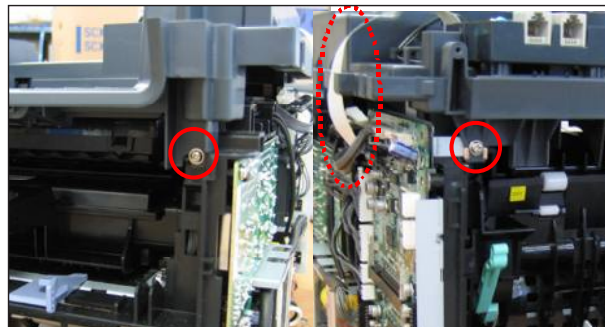

### 3.2.6 Fuser

1. Remove the rear cover. Remove the Guide rear by pushing both side and removing the hinge.

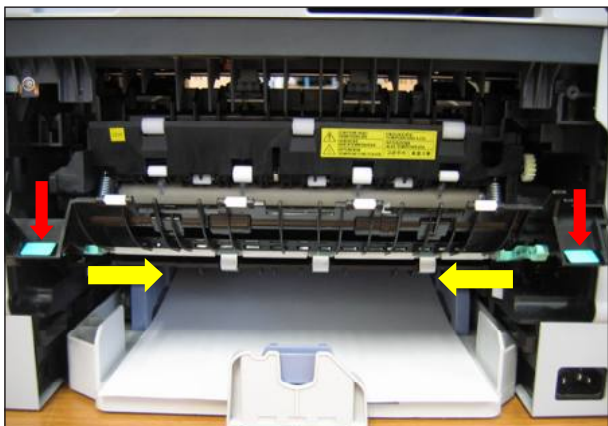

**CAUTION**

The fuser is very hot. So turn the printer off and wait until the printer to cool before replacing it.

2. Remove the 4 screw. And remove the fuser after remove the connector.

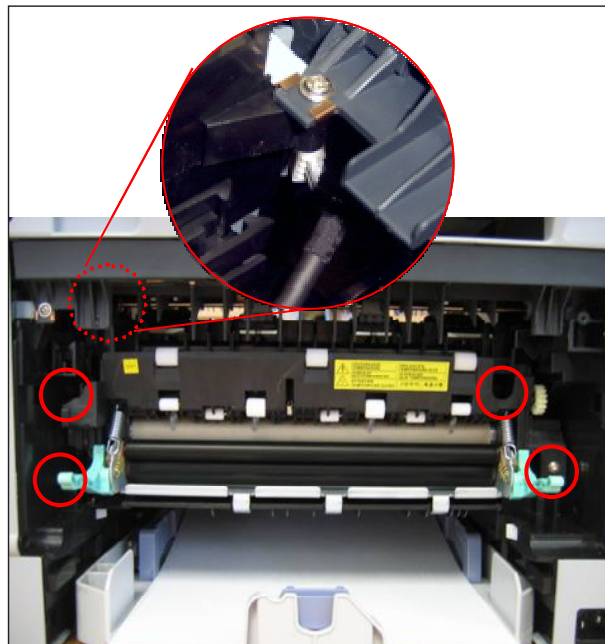



### 3.2.7 LSU

1. Release the LSU after remove the 4 screws and one connector.

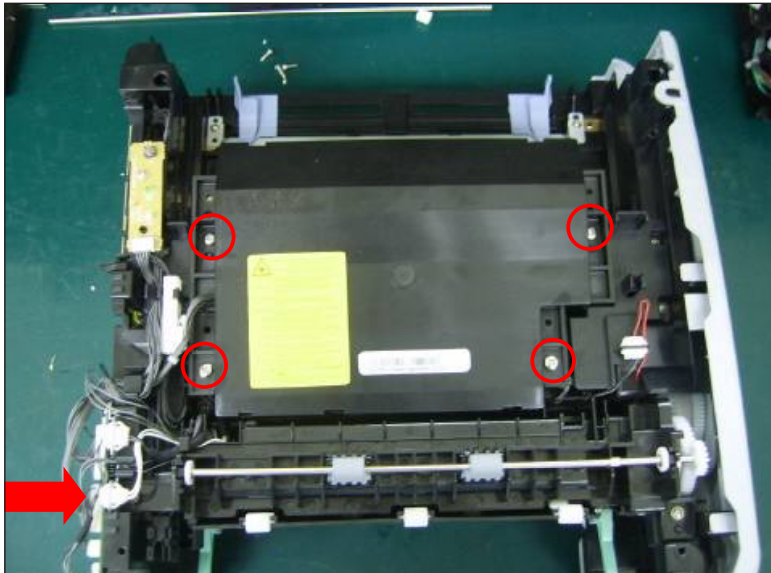

### 3.2.8 Main Drive Assy

- Before disassembly, remove the cassette, Cover front, Cover left, Cover rear.

1. Remove the rear cover. Remove the Guide rear by pushing both side and removing the hinge.
2. Remove the 4 screw. And remove the fuser after remove the connector.

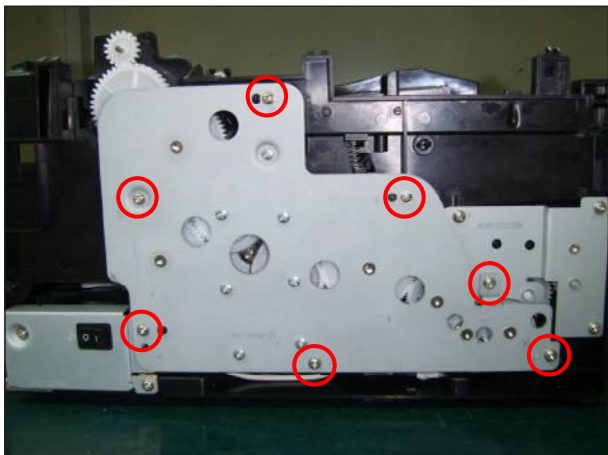

### 3.2.9 HVPS/SMPS/Main board

- Before disassembly, remove the cover front, cover rear, cover right.

1. Release the HVPS board after remove the 6 screws and 1 connector.

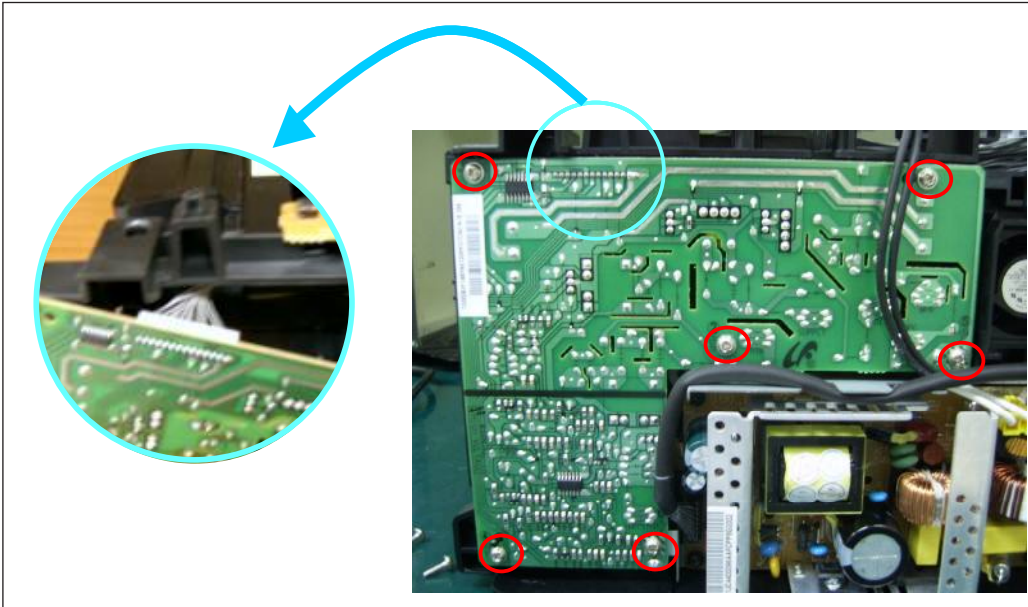

2. Release the SMPS board after remove the 4 screws and 2 connector.

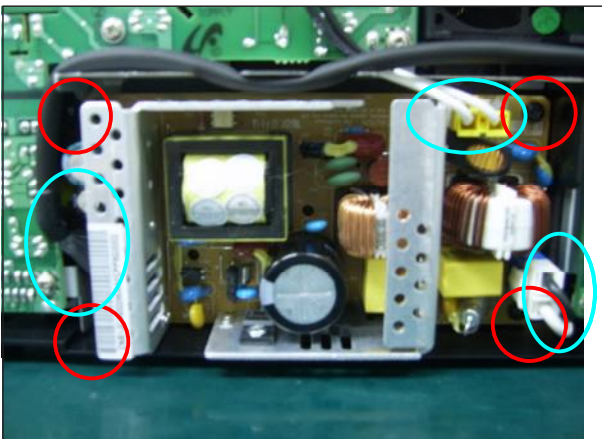

3. Release the Main board after remove the 4 screws and all harness.

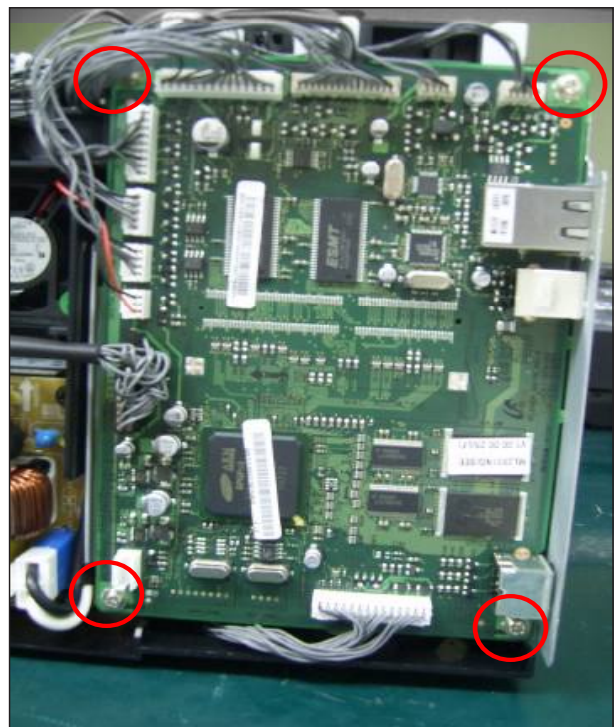

### 3.2.10 Transfer roller

1. Push HOLDER-TRANSFER, which holds the transfer roller and remove the roller from set.

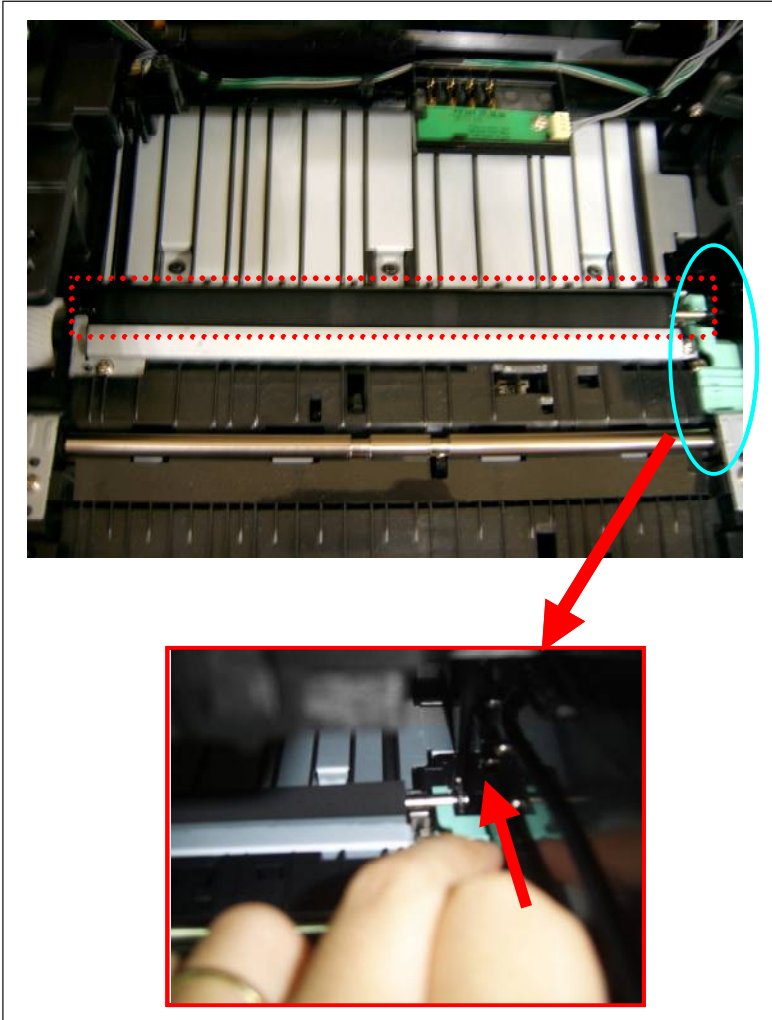

**Caution** - Be carefull not to touch the sponge of Transfer Roller.

### 3.2.11 Holder Pad unit

1. Remove the CASSETTE from SET.

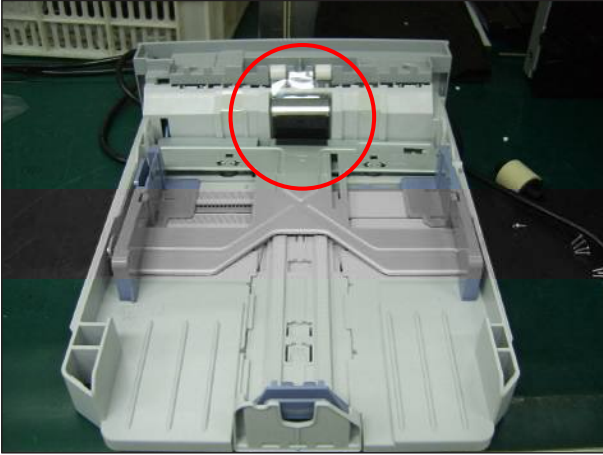

2. Disassemble HOLER-PAD after putting out three HOOKS

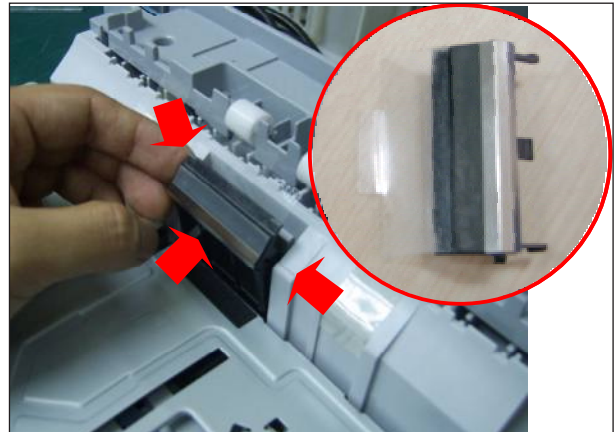

## 4. Alignment & Troubleshooting

This chapter describes the main functions for service, such as the product maintenance method, the test output related to maintenance and repair, DCU using method, Jam removing method, and so on. It includes the contents of manual.

### 4.1 Alignment and Adjustments

#### 4.1.1 Control Panel overview

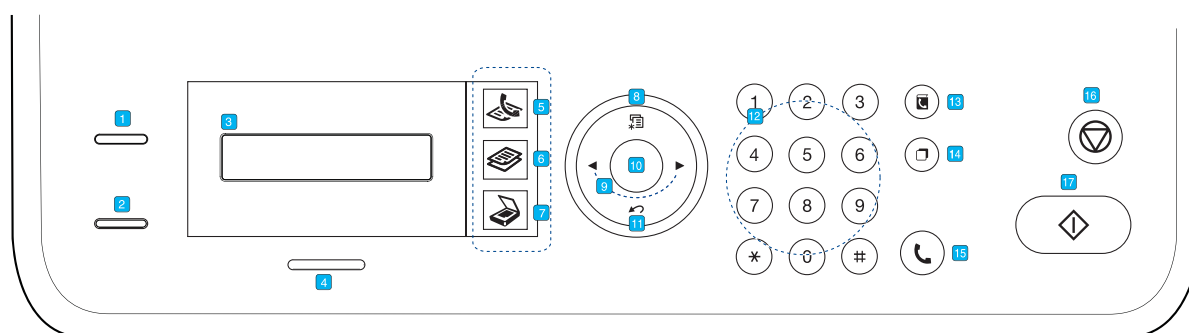

1	<b>ID Copy</b>	You can copy both sides of the ID Card like a driver's license to a single side of paper.
2	<b>Direct USB</b>	Allows you to directly print files stored on a USB Memory device when it is inserted into the USB memory port on the front of your machine. (SCX-4x28 Series only)
	<b>Reduce/Enlarge</b>	Makes a copy smaller or larger than the original. (SCX-4x24 Series only)
3	<b>Display</b>	Shows the current status and prompts during an operation.
4	<b>Status</b>	Shows the status of your machine.
5	<b>Fax</b>	Activates Fax mode.
6	<b>Copy</b>	Activates Copy mode.
7	<b>Scan/Email</b>	Activates Scan mode.
8	<b>Menu</b>	Enters Menu mode and scrolls through the available menus.
9	<b>Left/right arrow</b>	Scroll through the options available in the selected menu, and increase or decrease values.
10	<b>OK</b>	Confirms the selection on the screen.
11	<b>Back</b>	Sends you back to the upper menu level.
12	<b>Number keypad</b>	Dials a number or enters alphanumeric characters.
13	<b>Address Book</b>	Allows you to store frequently used fax numbers in memory or search for stored fax numbers or email addresses.
14	<b>Redial/Pause</b>	In ready mode, redials the last number, or in Edit mode, inserts a pause into a fax number.
15	<b>On Hook Dial</b>	Engages the telephone line.
16	<b>Stop/Clear</b>	Stops an operation at any time. In ready mode, clears/cancels the copy options, such as the darkness, the document type setting, the copy size, and the number of copies.
17	<b>Start</b>	Starts a job.

## 4.1.2 Understanding The Status LED

The color of the Status LED indicates the machine's current status.

Status		Description
Off		<ul style="list-style-type: none"> <li>The machine is powered off-line.</li> <li>The machine is in power save mode. When data is received, or any button is pressed, it switches to on-line automatically.</li> </ul>
Green	On	<ul style="list-style-type: none"> <li>The machine is powered on and can be used.</li> </ul>
	Blinking	<ul style="list-style-type: none"> <li>When the green LED slowly blinks, the machine is receiving data from the computer.</li> <li>When the green LED rapidly blinks, the machine is printing data.</li> </ul>
Red	On	<ul style="list-style-type: none"> <li>A problem has occurred such as a paper jam, cover open or no paper in the tray, so that the machine cannot continue the job.</li> <li>The toner cartridge is empty, or needs to be changed.</li> </ul>
	Blinking	<ul style="list-style-type: none"> <li>A minor error has occurred and the machine is waiting for the error to be cleared.</li> <li>The toner cartridge is low. Order a new toner cartridge.</li> </ul>

### 4.1.3 Paper path

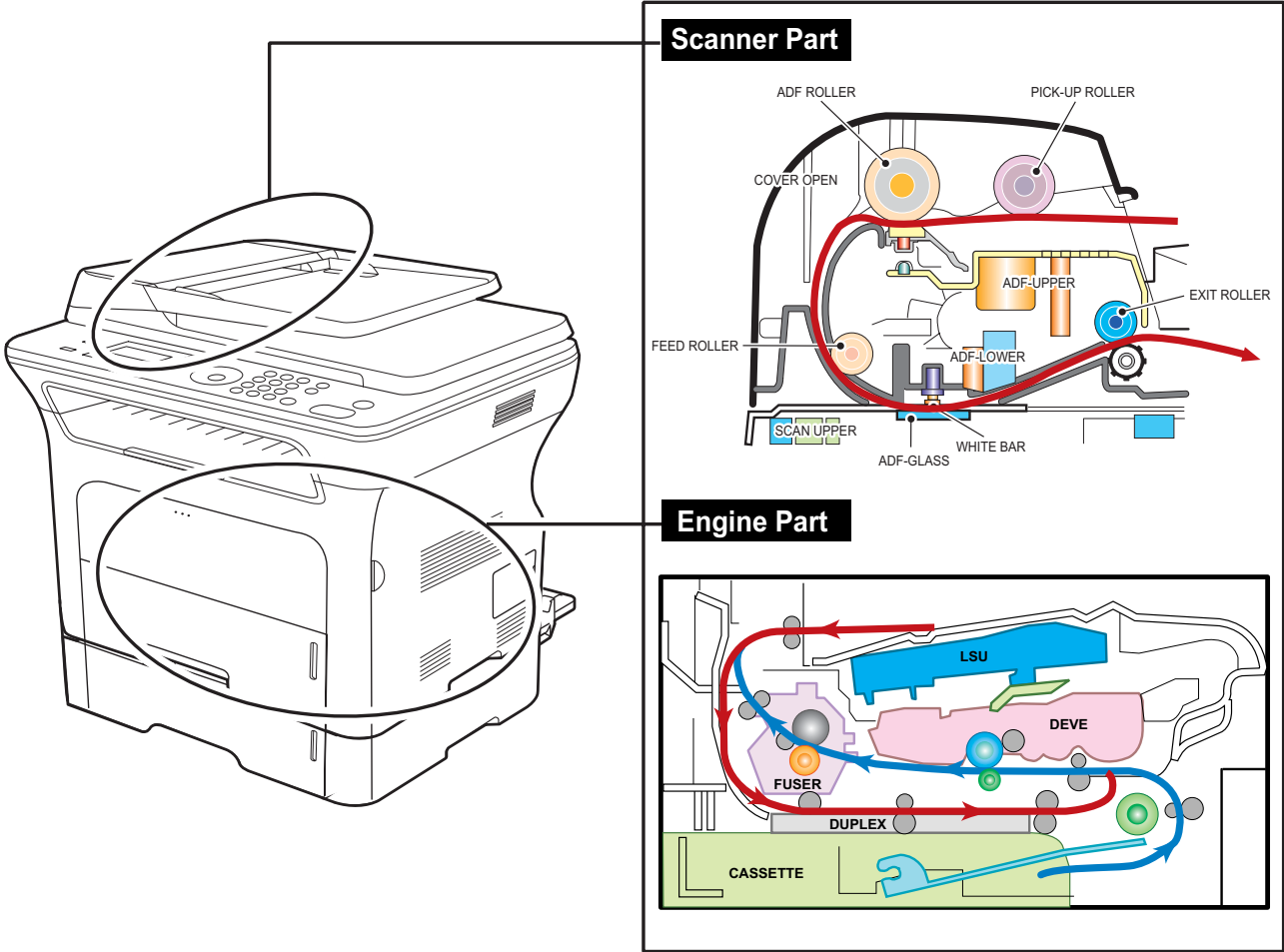

### 4.1.3.1 Clearing Document Jams

When an original jams while passing through the ADF, Document Jam appears on the display.

#### Input Misfeed

1. Remove any remaining pages from the ADF.
2. Open the ADF cover.

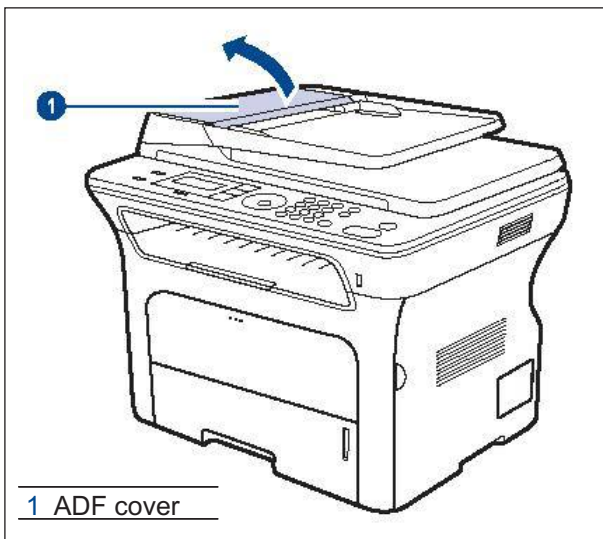

3. Rotate the bushing on the right end of the ADF roller toward the ADF (1) and remove the roller from the slot (2). Pull the document gently to the left and out of the ADF.

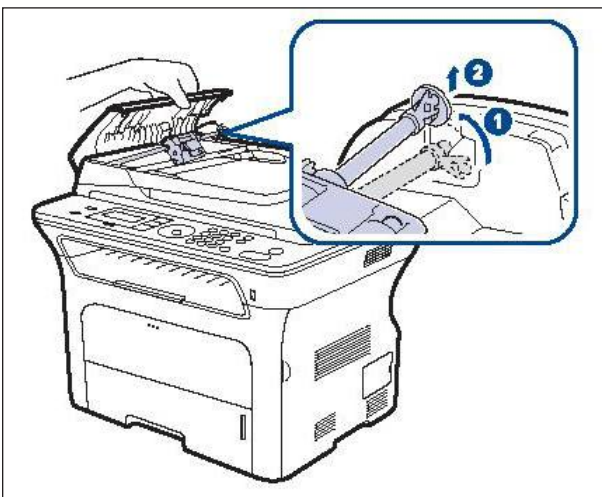

4. Align the left end of the ADF roller with the slot and push the right end of the ADF roller into the right slot (1). Rotate the bushing on the right end of the roller toward the document input tray (2).

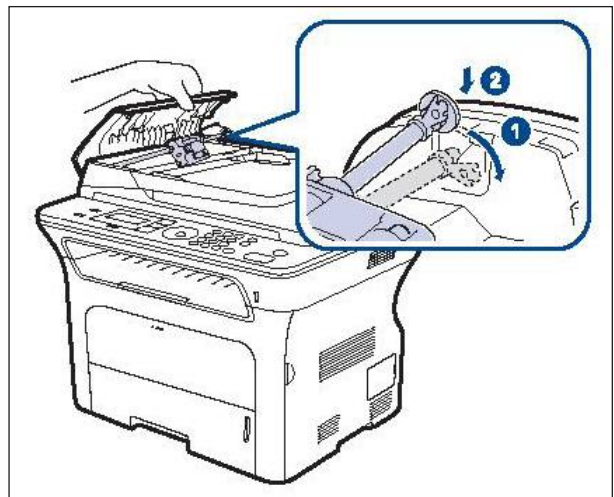

5. Close the ADF cover. Then load the removed page(s), if any, back into the ADF.



### Exit misfeed

1. Remove any remaining pages from the ADF.
2. Seize the misfeed paper, and remove the paper from the document output tray by carefully pulling it to the right using both hands.

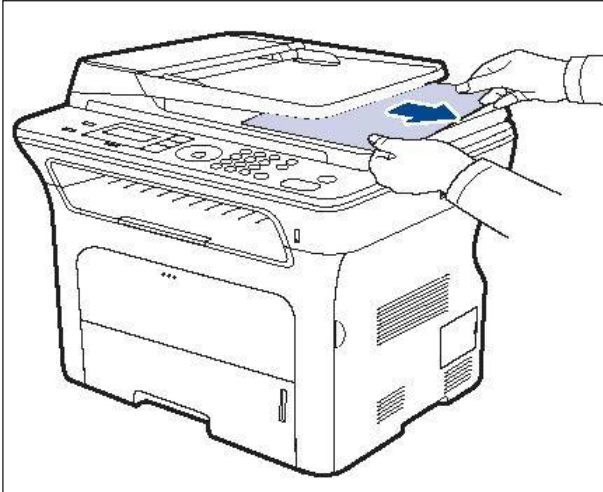

3. Load the removed pages back into the ADF.

### Roller misfeed

1. Open the scanner lid.
2. Seize the misfeed paper, and remove the paper from the feed area by carefully pulling it to the right using both hands.

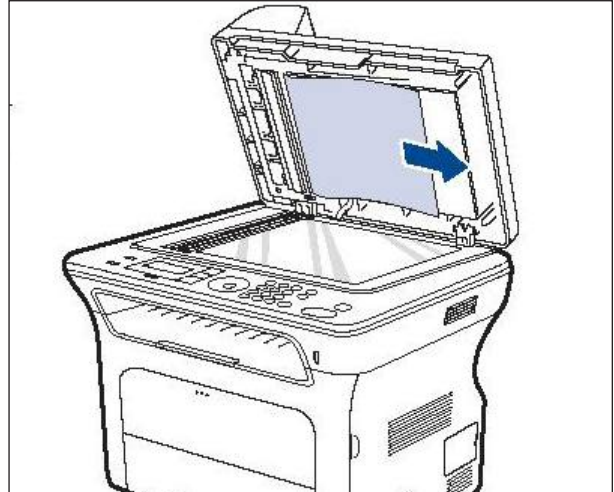

3. Close the scanner lid. Then load the removed pages back into the ADF.

### 4.1.3.2 Clearing paper jams

When a paper jam occurs, the warning message appears on the display screen. Refer to the table below to locate and clear the paper jam.

Message	Location of jam
Paper Jam 0 Open/Close Door	In the paper feed area or inside the machine
Paper Jam 1 Open/Close Door	Inside the machine
Paper Jam 2 Check Inside	Inside the machine or in the fuser area
Duplex Jam 0 Check Inside	Inside the machine
Duplex Jam 1 Open/Close Door	In the paper feed area or inside the machine

#### In the paper feed area

If paper is jammed in the paper feed area, follow the next steps to release the jammed paper.

1. Pull the tray open.

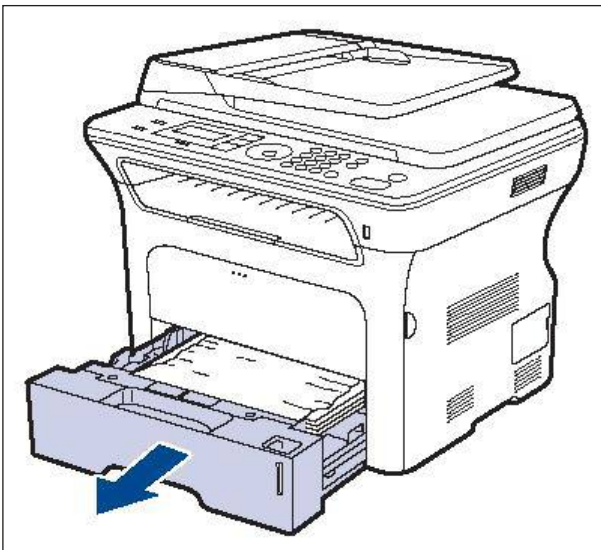

2. Remove the jammed paper by gently pulling it straight out as shown below.

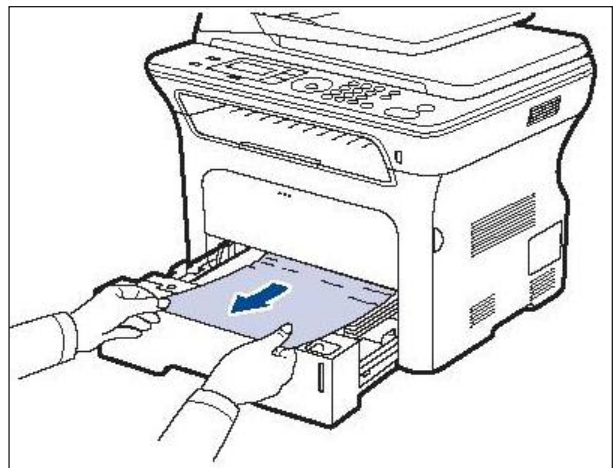

If the paper does not move when you pull, or if you do not see the paper in this area, check In the toner cartridge area.

3. Insert the tray back into the machine. Printing automatically resumes.

### In the manual tray

When you print using the manual tray and the machine detects that there is either no paper or that the paper has been improperly loaded, follow the next steps to release the jammed paper.

1. Check if the paper is stuck in the feeding area, and if so, pull it out gently and slowly.

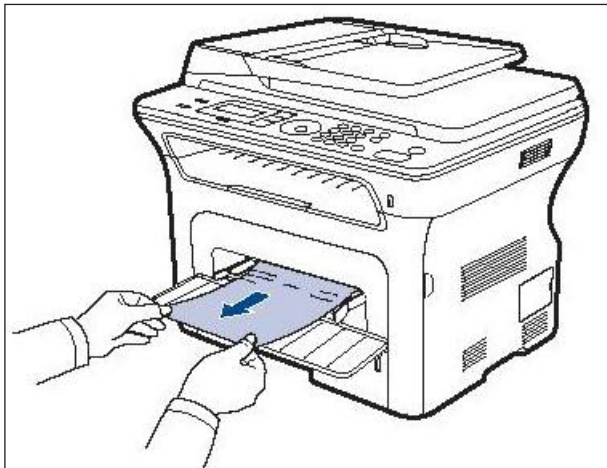

2. Load a paper into the manual tray.
3. Open the front cover and close it. The machine will resume printing.

### In the toner cartridge area

If paper is jammed in the toner cartridge area, follow the next steps to release the jammed paper.

1. Open the front cover and pull the toner cartridge out

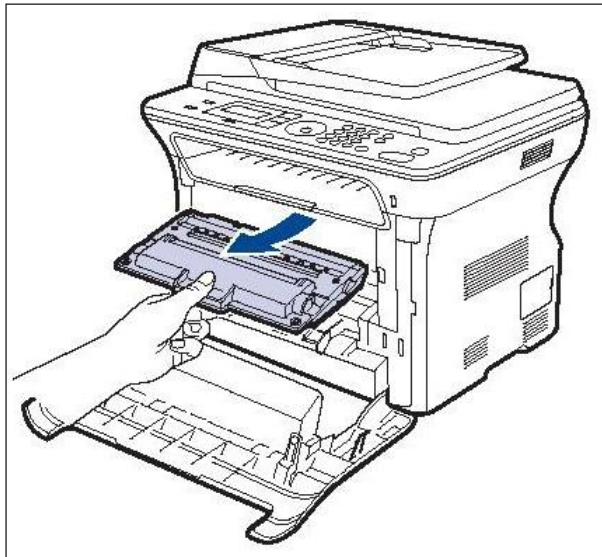

2. Remove the jammed paper by gently pulling it straight out as shown below.

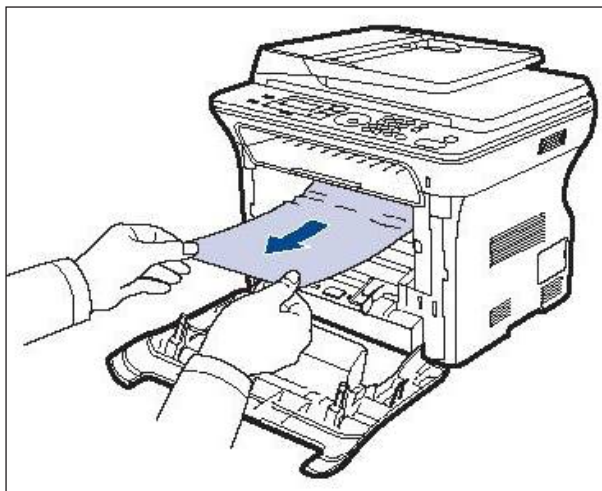

3. Replace the toner cartridge and close the front cover. Printing automatically resumes.

### In the paper exit area

If paper is jammed in the paper exit area, follow the next steps to release the jammed paper.

1. If a long portion of the paper is visible, pull it straight out. Open and close the front cover firmly. The machine will resume printing.

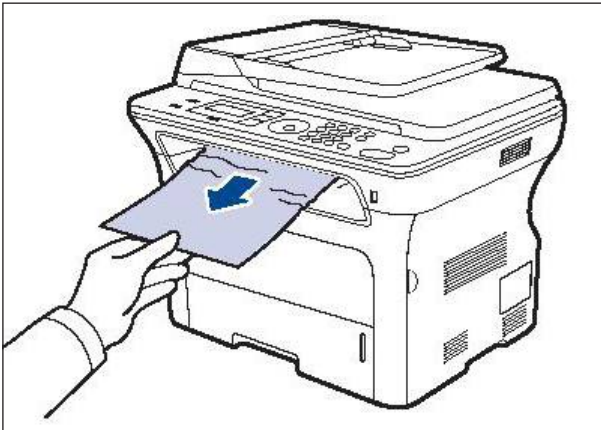

If you cannot find the jammed paper, or if there is any resistance removing the paper, stop pulling and go to step 2.

2. Open the rear cover.
3. Pull the guide rear on each side down and carefully take the jammed paper out of the machine. Return the guide rear to its original position.

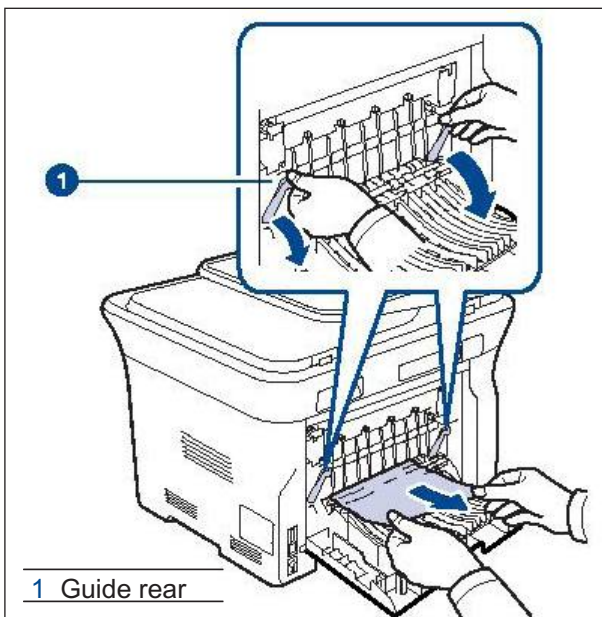

1 Guide rear

4. Close the rear cover. Printing automatically resumes.

### In the duplex unit area

If the duplex unit is not inserted correctly, paper jam may occur. Make sure that the duplex unit is inserted correctly.

1. Pull the duplex unit out of the machine.

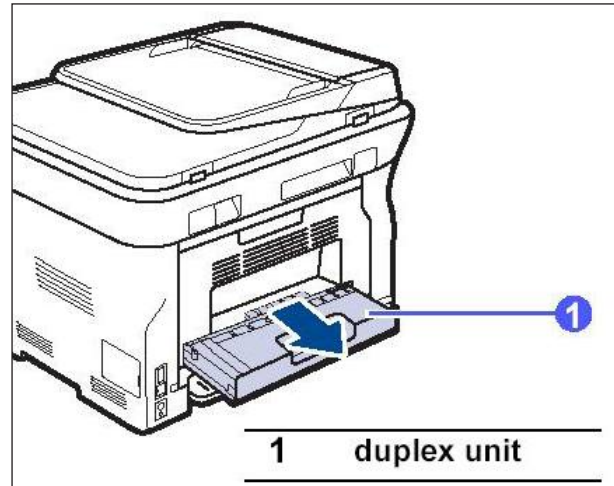

1 duplex unit

2. Remove the jammed paper from the duplex unit.

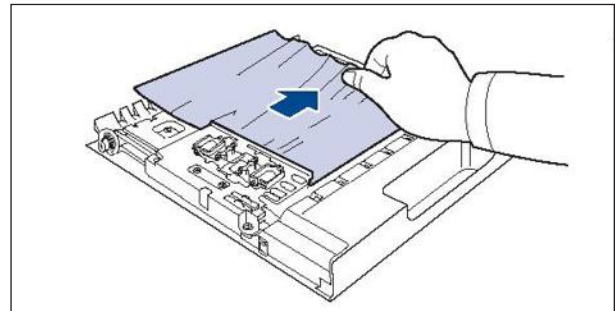

If the paper does not come out with the duplex unit, remove the paper from the bottom of the machine.

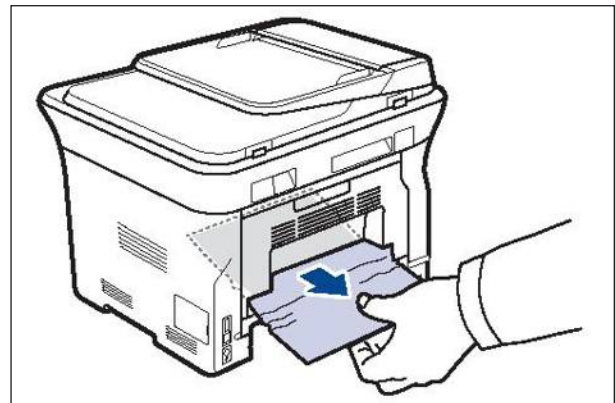

If you cannot find the jammed paper, or if there is any resistance removing the paper, stop pulling and go to step 3.

3. Open the rear cover.
4. Pull the guide rear on each side down and remove the paper. Return the guide rear to its original position.

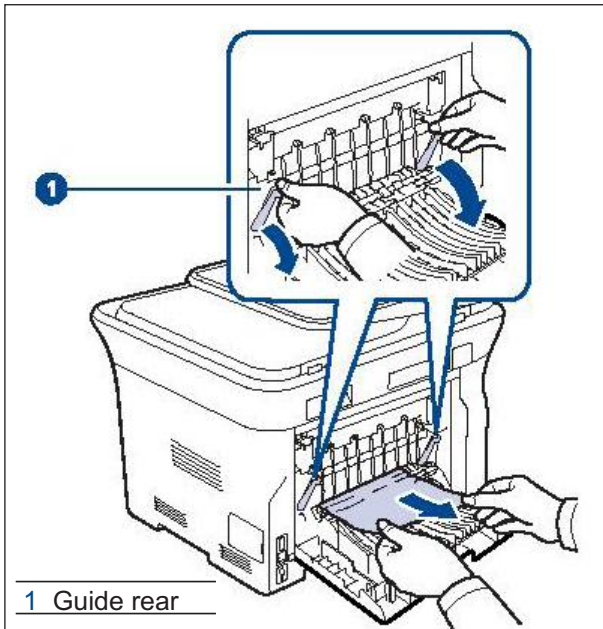

5. Close the rear cover. Printing automatically resumes.

### In the optional tray

If paper is jammed in the optional Tray, follow the next steps to release the jammed paper.

1. Pull the optional tray open.

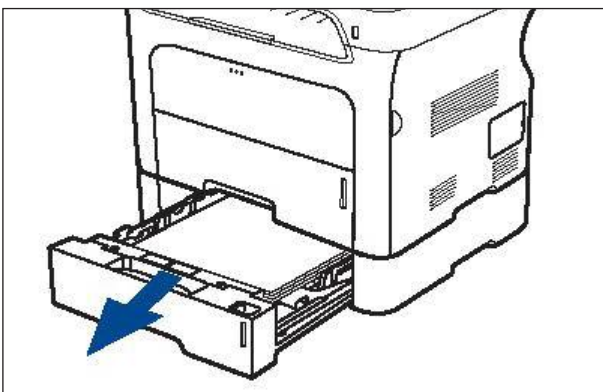

2. If you see the jammed paper, remove the paper from the machine by gently pulling it straight out as shown below.

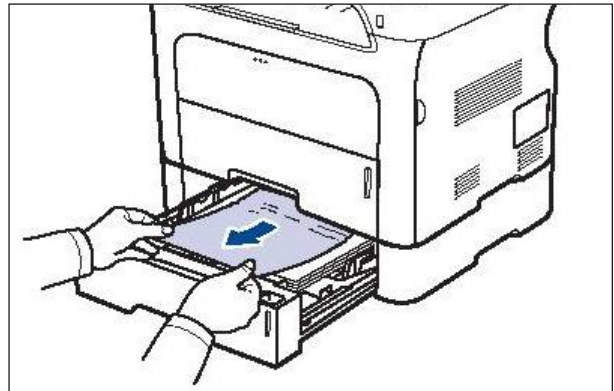

If you cannot find the jammed paper, or if there is any resistance removing the paper, stop pulling and go to step 3.

3. Pull the tray half.

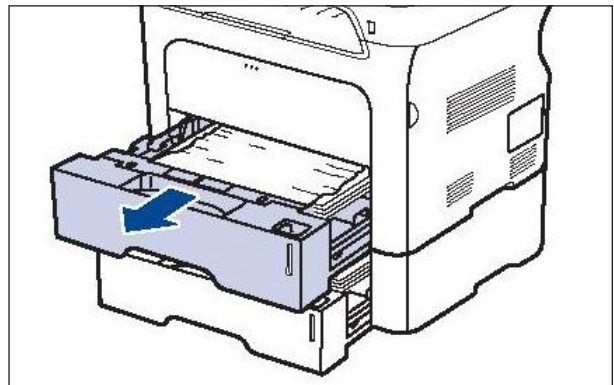

4. Remove the jammed paper by gently pulling the paper straight up and out.

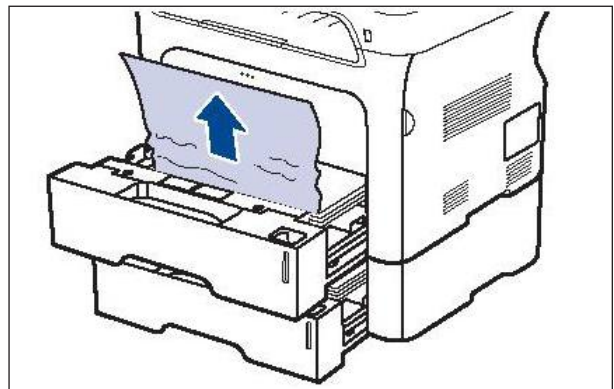

5. Insert the trays back into the machine. Printing automatically resumes.

## 4.1.4 Menu Map

The control panel provides access to various menus to set up the machine or use the machine's functions. These menus can be accessed by pressing Menu. Refer to the following diagram. Menus available in Fax, Copy, or Scan mode vary.

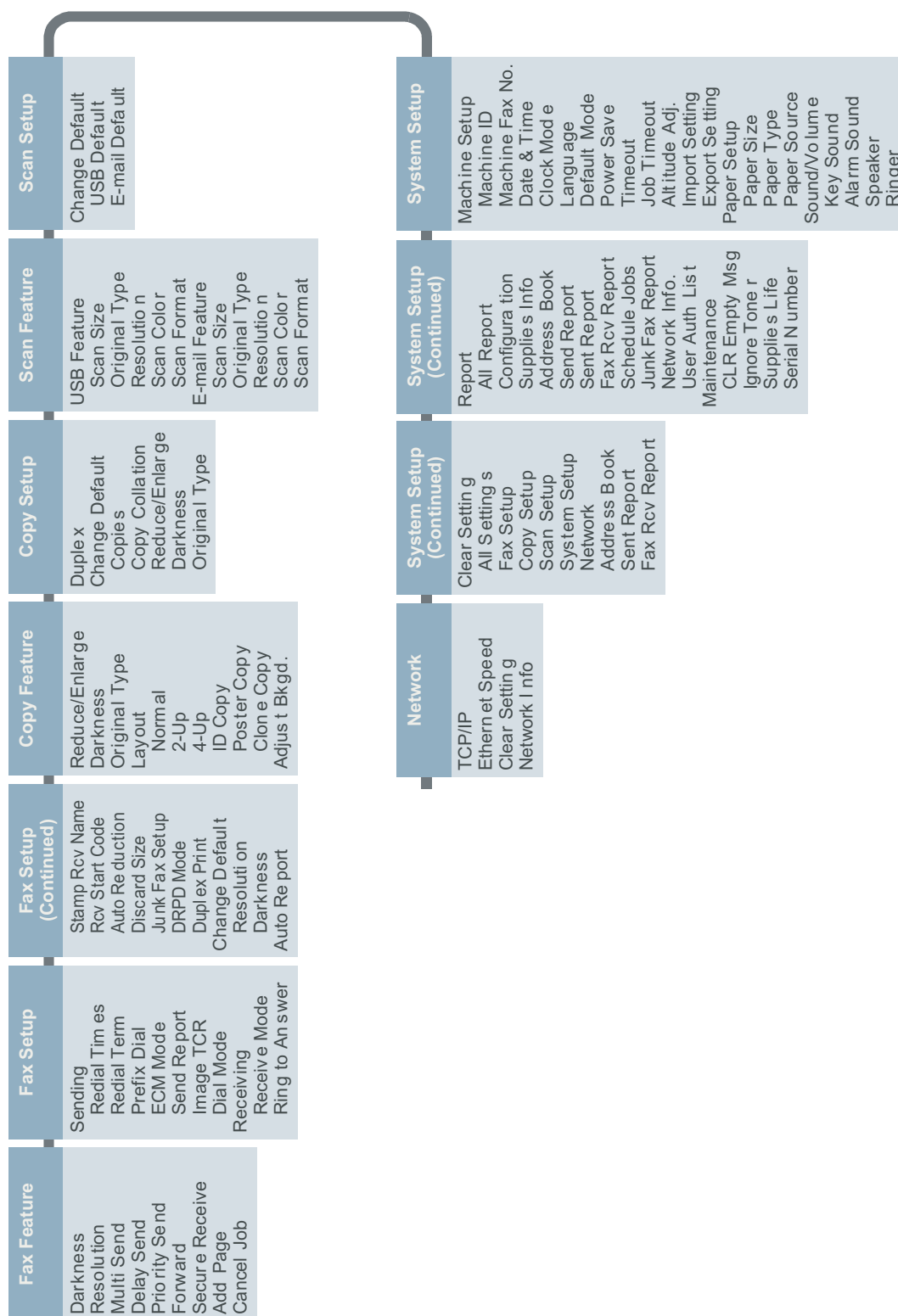

#### 4.1.4.1 Accessing to menus

---

The next steps are the example to print the menu map of this machine, and they are the general way to select menu and configure your machine.

1. Make sure your machine is properly connected all the necessary cables, and turn on the machine.
2. Press the Menu button until you see the menu (ex. Information) you want on the bottom line of the display.
3. Press the OK button to access the menu.
4. Press the Left/right arrow buttons until the menu item (ex. Menu Map) you want displays on the bottom line.
5. Press the OK button to confirm the selected item.
6. Press the Left/right arrow buttons until the menu item (ex. Print?) you want displays on the bottom line.
7. Press the OK button to process your selection, save your input or selection.  
An asterisk (\*) appears next to the selection on the display, indicating that it is now the default.
8. To exit the menu, press the Back button repeatedly, or the Stop button.

Note - If you want to set the basic menu items, please consult the user guide.







## 4.1.5 Tech Mode

### 4.1.5.1 How to Enter Tech Mode

In service (tech) mode, the technician can check the machine and perform various test to isolate the cause of a malfunction.

While in Tech mode, the machine still performs all normal operations.

#### To enter the Tech mode

To enter the Tech mode, press  →  →  →  →  →  →  in sequence, and the LCD briefly displays 'TECH', the machine has entered service (tech) mode.

### 4.1.5.2 Setting-up System in Tech Mode

In service (tech) mode, the technician can check the machine and perform various test to isolate the cause of a malfunction.

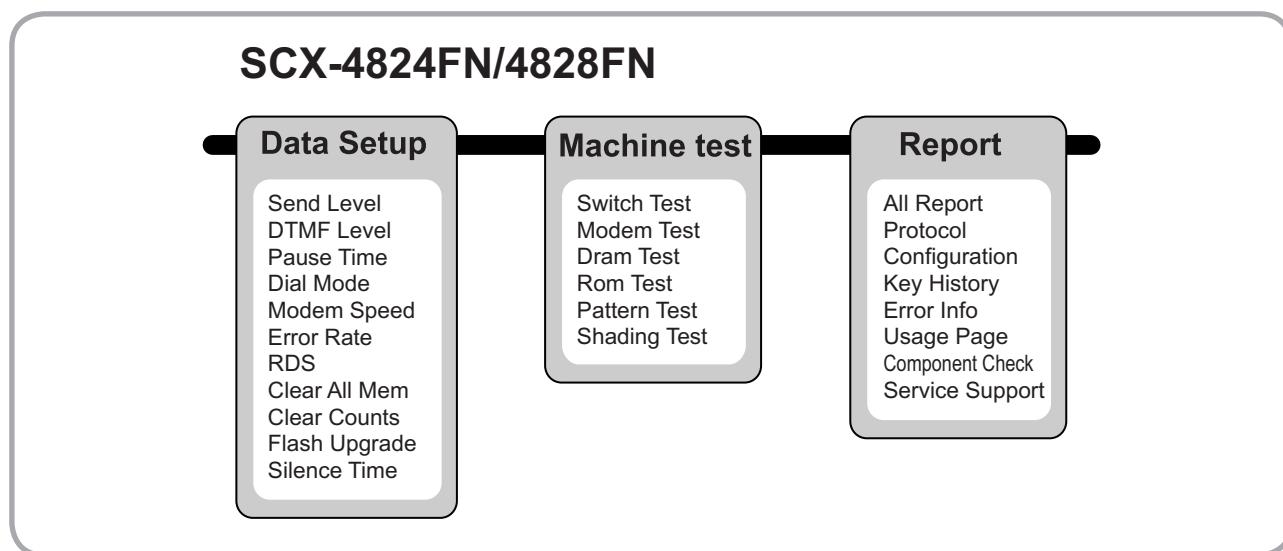



### 4.1.5.3 Data Setup

#### SEND LEVEL

You can set the level of the transmission signal. Typically, the Tx level should be under -12 dBm.

Caution : The Send Fax Level is set at the best condition in the shipment from factory. Never change settings arbitrarily.

#### DIAL MODE

This function can choose dial method.

\*Default : Dial(Dial/Pulse)

#### MODEM SPEED

You can set the maximum modem speed.

Communication is done with modem speed automatically set at lower speed when communicating with a slower speed modem since communication is done on the standard of the side where modem speed is low for transmission/reception. It is best set 33.6Kbps as default setting.

#### ERROR RATE

When the error rate is about exceed the set value, the Baud rate automatically adjusts to 2400 bps.

This ensures that the error rate remains below the set value.

You can select the rate between 5% and 10%.

#### CLEAR ALL MEMORY

The function resets the system to factory default settings.

This function is used to reset the system to the initial value when the product is functioning abnormally. All the values are returned to the default values, and all the information, which was set by the user, will be erased.

#### < Method >

1. Select the [MEMORY CLEAR] at the TECH MODE.
2. Push the OK button.
3. Select you country. (There are four country groups. Refer to the table below.)
4. Push the OK button then it will clear all memory.

*NOTICE : Always perform a memory clear after replacing the main board. Otherwise, the system may not operate properly.*

Country Group	USA/Canada	UK	Russia	Southafrica
Country	USA/Canada Mexico Brazil	UK Germany France Italy Spain Austria Netherlands Belgium Portugal Sweden Norway Denmark Finland Switzerland Greece Ireland Turkey	Russia India Oman Poland Bangladesh Kuwait Moroco Algeria Pakistan UAE Bahrain Srilanka Saudi Arabia Chile Peru Argentina Hungary Romania Bulgaria Czech	South Africa

## Flash Upgrade

The Firmware Upgrade function and has two methods, Local and Remote.

### 1) Local Machine Upgrade

- RCP(Remote Control Panel) mode

This method is for USB Port Connect to PC and activate RCP(Remote Control Panel) to upgrade the Firmware.

#### < Method >

How to Update Firmware using RCP

1. Connect PC and Printer with USB Cable.
2. Execute RCP and select Firmware Update.
3. Search Firmware file to update with Browse Icon.
4. Click Update icon, firmware file is transmitted to Printer automatically and printer is initialized when it finished.
5. Click Refresh icon and check what is updated.

- DOS Command mode

This method is just for USB Port. Connect to PC with USB cable and enter DOS Command to upgrade the Firmware

#### < Method >

1. The first of all, need the files : down.bat, down\_com.bin, fprt.exe, and Rom File: file name for upgrade. Save the files in the same folder.
2. In the DOS, input as below and push the enter key. Then, it will be automatically upgraded.
3. There are two commands for the conditions of product.
  - \* When the product is in idle condition down "rom file"
  - \* When the product is in Ready condition (TECH MODE DATA SETUP FLASH UPGRADE LOCAL) copy/b "rom file" lpt1
4. Do not turn off the power while upgrading process.

### 2) Remote Upgrade

This is a function that a fax with the latest firmware sends files to a fax in long distance through telephone line.

#### < Method >

1. Before remote upgrade, the latest firmware should be loaded into the machine. (TECH MODE DATA SETUP FLASH UPGRADE REMOTE)
2. Input the fax number, which needs to be upgraded. (Several faxes can be upgraded at the same time. In this case, enter the each fax number.)
3. After push the enter button, send the firmware file by calling to the appointed number. (Around 10~15 minutes needs to send the file.)

#### < Caution >

1. sending and receiving fax must be the same model.
2. A sending fax must be set up as ECM mode, and a receiving memory must be set up as 100%. If not, the function operates abnormally

## S/W of Maintenance

### 1. Clearing the Memory

- You can selectively clear information stored in your machine's memory.
  - 1) Press Menu on the control panel until Maintenance appears on the top line of the display.
  - 2) Press the scroll button (left-key or right-key) until you see Clear Memory on the bottom line and press OK
    - The first available menu item, Clear All Mem. displays on the bottom line.
    - See next page - There are some item to display on the LCD.
  - 3) Press the scroll button (left-key or right-key) until you see the item you want to clear.
  - 4) Press Enter. The selected memory is cleared and the display asks you to continue clearing the next item.
  - 5) To clear another item, press Enter and repeat steps 3 and 4
    - To return to Standby mode, press Stop/Clear.
    - As below item you can selectively clear information stored in your machine's memory.
- Clear All Mem.:
  - Clears all of the data stored in the memory and resets all of your settings to the factory default.
- Paper Setting:
  - Restores all of the Paper Setting options to the factory default.
- Copy Setup:
  - Restores all of the Copy Setup options to the factory default.
- Fax Setup:
  - Restores all of the Fax Setup options to the factory default.
- Fax Feature:
  - Cancels all of the scheduled fax jobs in the machine's memory.
  - As below item you can selectively clear information stored in your machine's memory.
- Advanced Fax:
  - Restores all of the Advanced Fax setting options to the factory default.
- Sound/Volume:
  - Resets the sound and volume settings to the factory default.
- Machine Setup:
  - Resets all of the system settings, such as the machine ID, date and time, display language and save modes, to the factory default.
- Sent Report:
  - Clears all of records of your faxes sent.
- RCV Report:
  - Clears all of records of your faxes received.
- Phone Book:
  - Clears the one-touch, speed and group dial numbers stored in the memory.

### 2. Adjust shading

- When the scan unit becomes dirty, it can alter the shading value.
- If your copy has black lines or is blurred, adjust the shading setting.
  - 1) Load a sheet of white paper into the ADF.
  - 2) Make machine Tech mode.
  - 3) Press Menu on the control panel and scroll until Machine Test displays.
  - 4) Scroll to Shading Test and Press OK.
  - 5) Select Shading&Print appears on the bottom line and press OK.
  - 6) Your machine picks up the paper and adjusts the shading value.
  - 7) After adjusting, shading value will be printed with graphic image.

### 3. Remote Diagnostic System(RDS)

- RDS and FT-EGT Automatic Ordering System, will enhance the quality and the speed of after sales service and monitor the performance of the MFP at the customer site.
- MFP Should be connected by MFP Server.

#### 3.1 Required components of RDS

RDS for MFP system consists of the following three components that communicate with each other

1. Main RDS Server connected to FAX-MODEM.
2. RDS Client Application.
3. RDS on MFP.

#### 3.2 Enable of RDS on MFP

This value is in Tech Mode.

The factory default for Consumables Status Update / Error Proactive value is Disabled.

#### < Method >

1. MFP Should be connected by RDS Server.
2. Service numbers should have the proper values.  
: TECH MODE -> DATA SETUP -> NOTIFY TONER -> 2.RDS -> Service Number.
3. Machine Serial No. should have the proper values.  
: TECH MODE -> DATA SETUP -> NOTIFY TONER -> 1.Toner -> Serial No.
4. Criter value input is optional, default is set to 1000-page.  
: TECH MODE -> DATA SETUP -> NOTIFY TONER -> 2.RDS -> Criter.Value.
5. Remote Test should be On  
: Maintenance -> Remote -> Test On
6. Change the password : if you forgot the Notify Toner password, enter the new password.  
: TECH MODE -> DATA SETUP -> NOTIFY TONER -> RDS -> RDS Password.
7. If you are to enable the RDS system, Notify Toner option should be [Off].

#### 3.3 Call setup & Release

In order to perform any RDS activity on a Customer MFP, the SVC will have to setup a call to it.

- On successful completion of call setup, one or more RDS functions can be executed before call release is manually initiated.
- When connecting to a device, RDS will query the MFP for serial no. If Serial No. is a zero-length string / invalid string, user will be prompted to enter a valid serial no. for the device. If the user chooses not to enter the serial number at that point, he can enter/edit it later also; Serial number will be configurable just like any other MFP parameter
- Following successful connection, following details of the MFP will be displayed :  
Tel. No, Model, Server Port (that is connected to), Status, Serial Number, Firmware Version, Engine Version, Emulation Version
- In case the established call is dropped due to an error condition, RDS Client Application will notify the user. It will then be necessary to manually request for another call setup to the desired MFP before any RDS function can be reattempted.
- If no activity is detected on a connected call for a maximum duration of 5 minutes (300 seconds), the call will be released / disconnected from the MFP-side.

#### 4.1.5.4 Machine Test

##### SWITCH TEST

Use this feature to test all keys on the operation control panel. The result is displayed on the LCD window each time you press a key.

##### MODEM TEST

Use this feature to hear various transmission signals to the telephone line from the modem and to check the modem. If no transmission signal sound is heard, it means the modem part of the main board malfunctioned.

##### DRAM TEST

Use this feature to test the machine's DRAM. The result appears in the LCD display. If all memory is working normally, the LCD shows << O K >>

##### ROM TEST

Use this feature to test the machine'S ROM. The result and the software version appear in the LCD display.

- FLASH VER : 1.00 V
- ENGINE VER :1.00V

##### PATTERN TEST

Using this pattern printout, you can check if the printer mechanism is functioning properly. It is needed in the production progress. Service person doesn't need to use it.

##### SHADING TEST

The function is to get the optimum scan quality by the specific character of the CCD(Charge Coupled Device). If the copy image quality is poor, perform this function to check the condition CCD unit.

##### < Method >

1. Select the [ADJUST SHADING] at the TECH MODE.
2. Push the SET UP button then an image will be scanned.
3. After the scan, CCD SHADING PROFILE will be print out.
4. If the printed image is different to the image, the CCD is defect.

**NOTICE :** When you test CCD, make sure that the cover is closed.

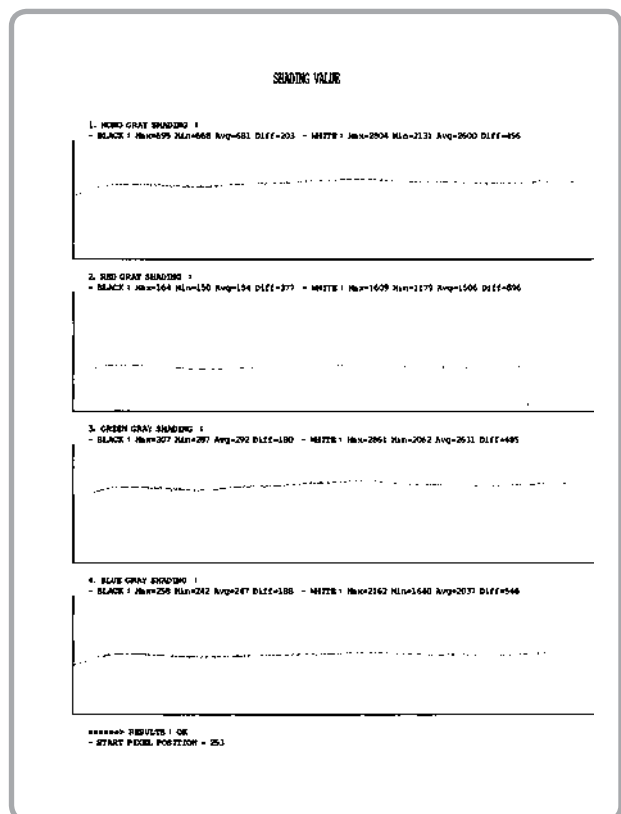

### 4.1.5.5 Report

#### PROTOCOL LIST

This list shows the sequence of the CCITT group 3 T.30 protocol during the most recent sending or receiving operation. Use this list to check for send and receive errors. If a communication error occurs while the machine is in TECH mode, the protocol list will print automatically.

#### OTHER ITEM

This list provides a list of the user system data settings and tech mode settings.

#### Configuration report

#### Configuration Report

Date & Time : 24-DEC-2007 22:51 MON  
Model Name : SCX-4x28 Series

Options	Item	Status
Default Copies	[1-99]	1
Default Reduce/Enlarge	[Org.(100%)/LGL->LTR(78%)...]	Org.(100%)
Default Darkness	[Light/Normal...]	Normal
Default Original Type	[Text/ Text/Photo...]	Text
Paper Size(Tray 1)	[Letter/A4...]	A4
Paper Size(Manual Feeder)	[Letter/A4...]	A4
Copy Tray	[Tray 1/Tray 2...]	Auto
Paper Type(Tray 1)	[Plain Paper/Bond...]	Plain Paper
Paper Type(Manual Feeder)	[Plain Paper/Bond...]	Plain Paper
Speaker	[On/Off...]	Comm
Ringer	[Off/Low...]	Mid
Key Sound	[On/Off]	Off
Alarm Sound	[On/Off]	On
Clock Mode	[12 Hours/24 Hours]	24 Hours
Language	[English/FRANCAIS...]	English
Power Save	[5/10/15...]	15 Min
Timeout	[15/30/60...]	30 Sec
Scan PWR Save	[0.5/1/2]	0.5 Hour(s)
Altitude Adjustment	[Plain/High...]	Plain
Firmware/Engine Version	: 1.00.00.18	0.01.21
Emulation Version	: PCL5e 5.69 12-24-2007 PS3 1.72.166 11-20-2007 TIFF 0.86.00 01-02-2008	PCL6 5.57 11-28-2007 PDF VL.00.50 12-21-2007
Installed Date	: 2007. 11. 19	
Total Page Count	: 193	
CRU Prints	: 193	(85%)
ADF/Platen Scan Page Counts	: 0	16
IP Address/Memory Size	: 192.0.0.192	128 Mbyte

## supplies information report

## Supplies Information Report

Date & Time : 24-DEC-2007 22:52 MON  
Model Name : SCX-4x28 Series

---

## Cartridge Information

Toner Remaining : 85%  
Equivalent page printed : 314  
  
Dot Count : 425021900  
Total Page Counts : 195  
Motor on time : 1519  
Clear Toner : 0  
Replaced Toner Counts : 0  
Supplier ID : PT285EUR

## Scan Information

ADF Scan Page Counts : 0  
Platen Scan Page Counts : 16

## Cartridge Information

Capacity : 2 K  
Supplier :  
Product Date :  
Serial : CRUM-INIT\_\_TONER

## 4.1.6 EDC Mode

EDC Mode is independently controled system f/w and diagnose printer's each function.

### ■ Method to enter

1. After turn on the system power, check the "Ready" message on the LCD.
2. To enter the EDC Mode, Push the button like next time.  
"Menu → Stop → Left arrow → Back → OK → Right arrow"
3. The message "COMPONENT TEST Press Menu Key" display on the LCD.
4. To get out of the EDC Mode, Press the "Stop" key

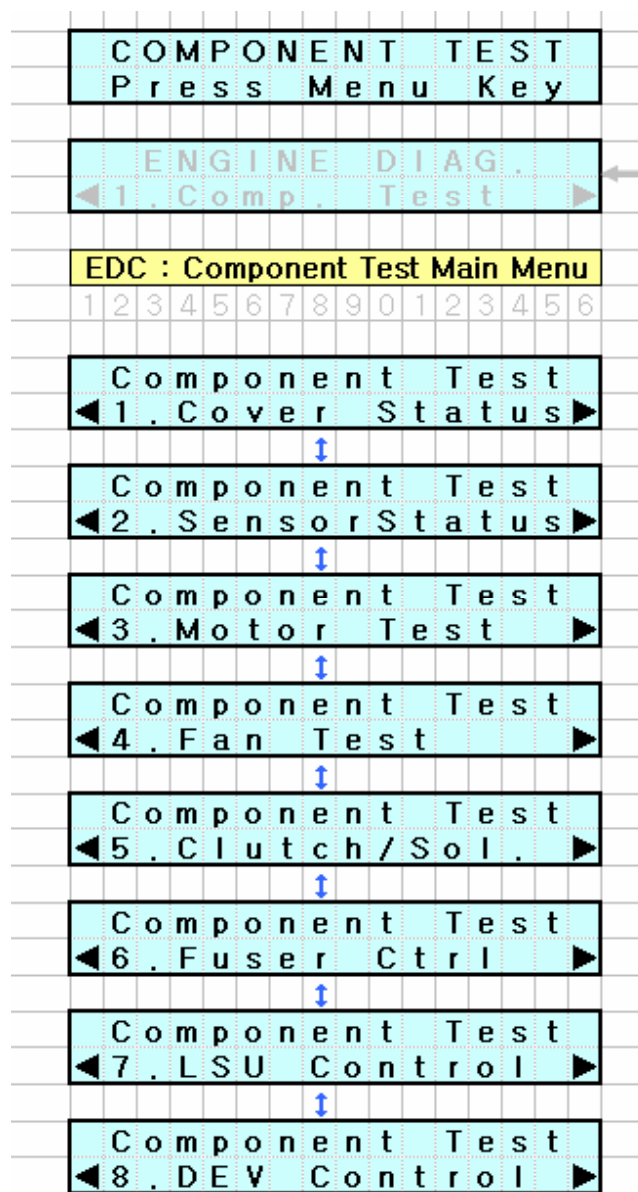



## ■ EDC Mode Menu

### 0. Cover Status

Item	Description
Front Cover	When the front cover opened, "Open" message display LCD. If the front cover closed, "Closed" message display LCD.

### 1. Sensor Status

Item	Description
Regi/Feed/Exit Sensor	If actuator is checked by sensor, "Without Paper" message will be displayed. if not, "With Paper" will be.
Empty	If paper exists in the tray, "Present" will be displayed. If not, "Empty" will be.

### 2. Motor Test

Item	Description
Main Mtr Nor.	If "OK" key is pushed after "ON" displayed, motor will be run. Main motor will auto - stop after 60 seconds and "OFF" message will be displayed.
Slow	If "OK" key is pushed after "ON" displayed, motor will be slowly run. Main motor will auto - stop after 60 seconds and "OFF" message will be displayed.

### 3. Fan Test

Item	Description
Fuser Fan	If "OK" key is pushed after "ON" displayed, fan will be run. Fuser fan will auto - stop after 10 seconds and "OFF" message will be displayed.
SMPS Fan	If "OK" key is pushed after "ON" displayed, fan will be run. SMPS fan will auto - stop after 10 seconds and "OFF" message will be displayed.
LSU Fan	If "OK" key is pushed after "ON" displayed, fan will be run. LSU fan will auto - stop after 10 seconds and "OFF" message will be displayed.

### 4. Clutch Test

Item	Description
Pick up Clutch	When "OK" key is pushed after "ON" message displayed, clutch turn on. pick up clutch will be turn off after 3 seconds and "OFF" message will be displayed.
Regi Clutch	When "OK" key is pushed after "ON" message displayed, clutch turn on. pick up clutch will be turn off after 3 seconds and "OFF" message will be displayed.

### 5. Fuser Ctrl

Item	Description
Temp Control	Fuser on and off. "ON" is selected, fuser will be active and display the fuser temperature [XXX] but "OFF" is selected, fuser will be stop and [0] display
Fuser Temp.	Fuser temperature displayed on LCD (example: [170] )

### 6. LSU Control

Item	Description
LD Power	When "OK" key is pushed after "ON" message displayed, "OFF" message will be displayed after 10 seconds
LSU Motor	If "OK" key is pushed after "ON" displayed, motor will be run. LSU motor will auto - stop after 10 seconds and "OFF" message will be displayed.
LSU Ready	If "OK" key is pushed after "ON" displayed, motor will be run. "1" message will be displayed.
Hsync	If "OK" key is pushed after "ON" displayed, motor will be run. "1" message will be displayed.

### 7. DEV Control

Item	Description
THV (+)	If "OK" key is pushed after "ON" displayed, THV (+) will be turned on.
THV (-)	If "OK" key is pushed after "ON" displayed, THV (-) will be turned on.
Dev Bias	If "OK" key is pushed after "ON" displayed, Dev Bias will be turned on.
MHV Bias	If "OK" key is pushed after "ON" displayed, MHV Bias will be turned on.

## ■ ACRONYMS AND ABBREVIATIONS

- DEV - Developing High Voltage
- EDC - Embedded Diagnostic Control
- F/W – Firmware
- HVPS – High Voltage Power Supply
- H/W - Hardware
- LD – Laser Diode
- LSU – Laser Scanning Unit
- MHV - Main High Voltage (Charge Voltage)
- OPC - Optical Photo Conductor
- SCF - Second Cassette Feeder
- THV - Transfer High Voltage

### 4.1.7 Abnormal Image Printing and Defective Roller

If abnormal image prints periodically, check the parts shown below.

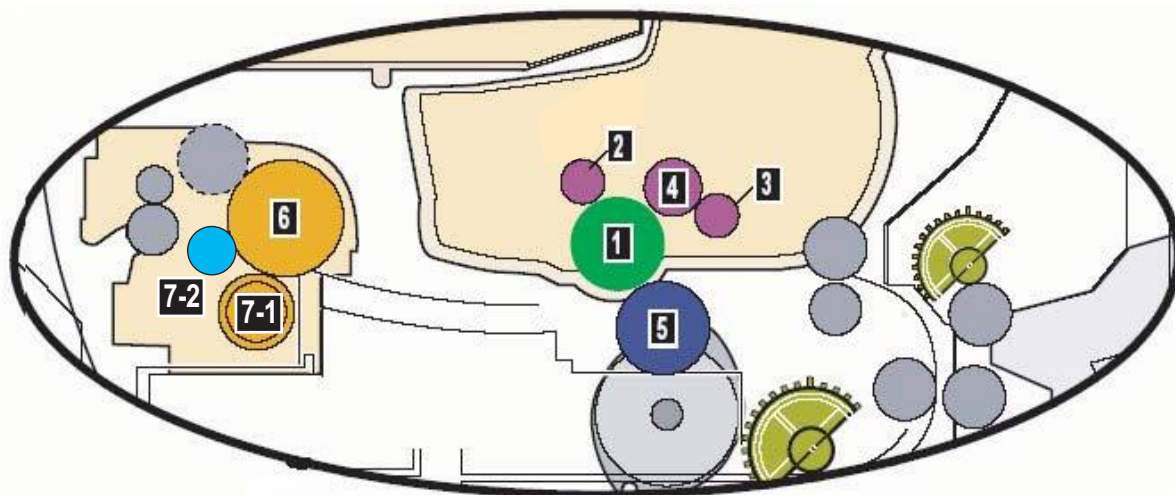

No	Roller	Abnormal image period	Kind of abnormal image
1	OPC Drum	75.5mm	White spot, Block Spots
2	Charge Roller	26.7mm	Block Spot and Periodic Band
3	Supply Roller	47.1mm	Periodic Band by little difference of density
4	Developing Roller	35.2mm	White Spot, Horizontal black band
5	Transfer Roller	47mm	Ghost, Damaged Image by abnormal transfer
6	Heat Roller	77.8mm	Black Spots or Vertical Black Band
7-1	Pressure Roller _1st	62.8mm	Blackground
7-2	Pressure Roller _2st	37.7mm	Blackground

## 4.1.8 Error Message

Messages appear on the control panel display to indicate the machine's status or errors. Refer to the tables below to understand the messages' meaning and correct the problem if necessary. Messages and their meanings are listed in alphabetical order.

- xxx indicates the media type.
- yyy indicates the tray.

Message	Meaning	Suggested solutions
<b>[COMM. Error]</b>	The machine has a communication problem.	Ask the sender to try again.
<b>[Incompatible]</b>	The machine has received a fax from which is registered as a junk fax.	The received fax data will be deleted. Reconfirm junk fax setup.
<b>[Line Error]</b>	Your machine cannot connect with the receiving fax machine or has lost contact because of a problem with the phone line.	Try again. If the problem persists, wait an hour or so for the line to clear and try again. Or, turn the ECM mode on.
<b>[No Answer]</b>	The receiving fax machine has not answered after several redial attempts.	Try again. Make sure that the receiving machine is operational.
<b>[Stop Pressed]</b>	Stop/Clear has been pressed during an operation.	Try again.
<b>[yyy] Paper Empty</b>	There is no paper in the tray.	Load paper in the tray.
<b>[yyy] Paper Mismatch</b>	The paper size specified in the printer properties does not match the paper you are loading.	Load the correct paper in the tray.
<b>Authentication Failure</b>	The ID or password you entered is incorrect.	Enter the correct ID or password.
<b>Cancel? ◀ Yes ▶</b>	Your machine's memory has become full while trying to store an original into memory.	To cancel the fax job, press the OK button to accept Yes. If you want to send those pages that have been successfully stored, press the OK button to accept No. You should send the remaining pages later, when memory is available.
<b>Connection Error</b>	Connection with the SMTP server failed.	Check the server settings and the network cable.
<b>Data Read Fail Check USB Mem.</b>	Time expired while reading data.	Try again.
<b>Data Write Fail Check USB Mem.</b>	Storing to the USB memory failed.	Check the available USB memory space.

Message	Meaning	Suggested solutions
<b>Document Jam</b>	The loaded original has jammed in the ADF.	Clear the jam.
<b>Door Open</b>	The front cover is not securely latched.	Close the cover until it locks into place.
<b>Duplex Jam 0 Check Inside</b>	Paper has jammed during duplex printing. This is applicable only to machines with this feature.	Clear the jam.
<b>Duplex Jam 1 Open/Close Door</b>	Paper has jammed during duplex printing. This is applicable only to machines with this feature.	Clear the jam.
<b>Enter Again</b>	You entered an unavailable item.	Enter the correct item again.
<b>File Format Not Supported</b>	The selected file format is not supported.	Use the correct file format.
<b>Fuser Fan Locked</b>	There is a problem in the cooling fan of the machine.	Open and then close the front cover.
<b>Group Not Available</b>	You have tried to select a group location number where only a single location number can be used, such as when adding locations for a Multiple Send operation.	Use a speed dial number or dial a number manually using the number keypad.
<b>Install Toner</b>	The toner cartridge is not installed.	Install the toner cartridge.
<b>Invalid Toner</b>	The toner cartridge you have installed is not for your machine.	Install the a Samsunggenuine toner cartridge designed for your machine.
<b>IP Conflict</b>	The network IP address you have set is being used by someone else.	Check the IP address and reset it if necessary.
<b>Line Busy</b>	The receiving fax machine did not answer or the line is already engaged.	Try again after a few minutes.
<b>Low Power</b>	The machine is in the previous stage of the power save mode.	When data is received, it switches to on-line automatically.
<b>Mail Exceeds Server Support</b>	The mail size is larger than the supported size by SMTP server.	Divide your mail or reduce the resolution.
<b>Main Motor Locked</b>	There is a problem in the main motor.	Open and then close the front cover.
<b>Memory Full</b>	The memory is full.	Delete unnecessary fax jobs and retransmit after more memory becomes available. Alternatively, split the transmission into more than one operation.
<b>Not Assigned</b>	The speed button or speed dial number you tried to use has no number assigned to it.	Enter the number manually using the number keypad or store the number or address.

Message	Meaning	Suggested solutions
<b>Not Available Try Again Later</b>	Can not perform the task immediately because too many tasks are running at once.	Try again when current task is completed.
<b>One Page is Too Large</b>	Single page data exceeds the configured mail size.	Reduce the resolution and try again.
<b>Operation Not Assigned</b>	You are in the Add Page/Cancel Job operation, but there are no jobs stored.	Check the display to see if there are any scheduled jobs.
<b>Out-Bin Full</b>	The output tray of the machine is full of paper.	Remove paper.
<b>Paper Jam 0 Open/Close Door</b>	Paper has jammed in the feeding area of the tray.	Clear the jam.
<b>Paper Jam 1 Open/Close Door</b>	Paper has jammed inside the machine.	Clear the jam.
<b>Paper Jam 2 Check Inside</b>	Special print media has jammed in the paper exit area.	Clear the jam.
<b>Replace Toner</b>	This message appears between Toner Empty and Toner Low status.	Replace the toner cartridge with a new one.
<b>Retry Redial?</b>	The machine is waiting for a specified time interval to redial a previously busy station.	You can press OK to immediately redial, or Stop/Clear to cancel the redial operation.
<b>Scanner locked</b>	The scanner module is locked	Unlock the scanner and press Stop/Clear.
<b>Self Diagnostics Temperature</b>	The engine in your machine is checking problems detected.	Wait a few minutes.
<b>Self Diagnostics LSU</b>	The LSU (Laser Scanning Unit) in your machine is checking problems detected.	Wait a few minutes.
<b>Send Error (AUTH)</b>	There is a problem in SMTP authentication.	Configure the authentication setting.
<b>Send Error (DNS)</b>	There is a problem in DNS.	Configure the DNS setting.
<b>Send Error (POP3)</b>	There is a problem in POP3.	Configure the POP3 setting.
<b>Send Error (SMTP)</b>	There is a problem in SMTP.	Change to the available server.
<b>Send Error (Wrong Config)</b>	There is a problem on the network interface card.	Configure your network interface card correctly.

Message	Meaning	Suggested solutions
<b>Toner Empty</b>	The toner cartridge has run out. The machine stops printing. Press OK to toggle the message to Stop or Continue. ◀ Stop ▶	You can select the option among Stop or Continue with the left/right arrow. If you select Stop by pressing OK on the control panel, the machine stops printing. If you select Continue, the machine keeps printing, but the quality cannot be guaranteed. If you do not select any, the machine will work as Stop is selected. Replace the toner cartridge with a new one.
<b>Toner Exhausted</b>	The lifespan of the toner cartridge which the arrow indicates is reached.	This message appears when the toner is completely empty, and your machine stops printing. Replace the corresponding toner cartridge with a Samsunggenuine cartridge.
<b>Toner Low</b>	The corresponding toner cartridge is almost empty.	Take out the toner cartridge and thoroughly shake it. By doing this, you can temporarily reestablish printing operations.
<b>Updating Data Please Wait...</b>	This message appears when there is a change in the system setting or when you back up a data.	Do not turn the power off when this message is showing. Changes may not be saved and datas can be lost.

## 4.2 Troubleshooting

### 4.2.1 Procedure of Checking the Symptoms

Before attempting to repair the printer first obtain a detailed description of the problem from the customer.

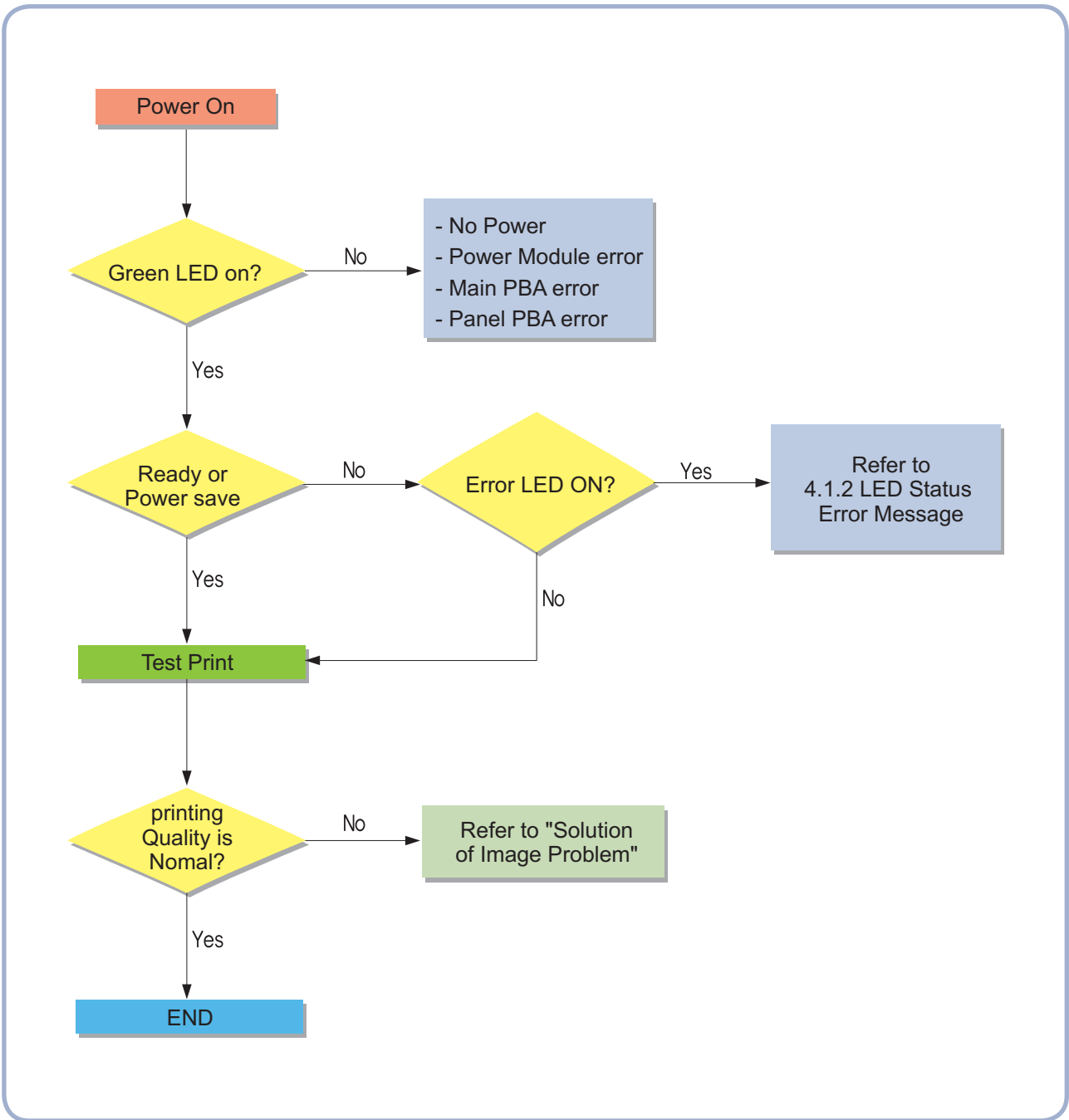



## 4.2.2 The cause and solution of Bad image

### 1) Vertical Black Line and Band

Description : 1. Straight thin black vertical line occurs in the printing.  
2. Dark black vertical band occur in the printing.

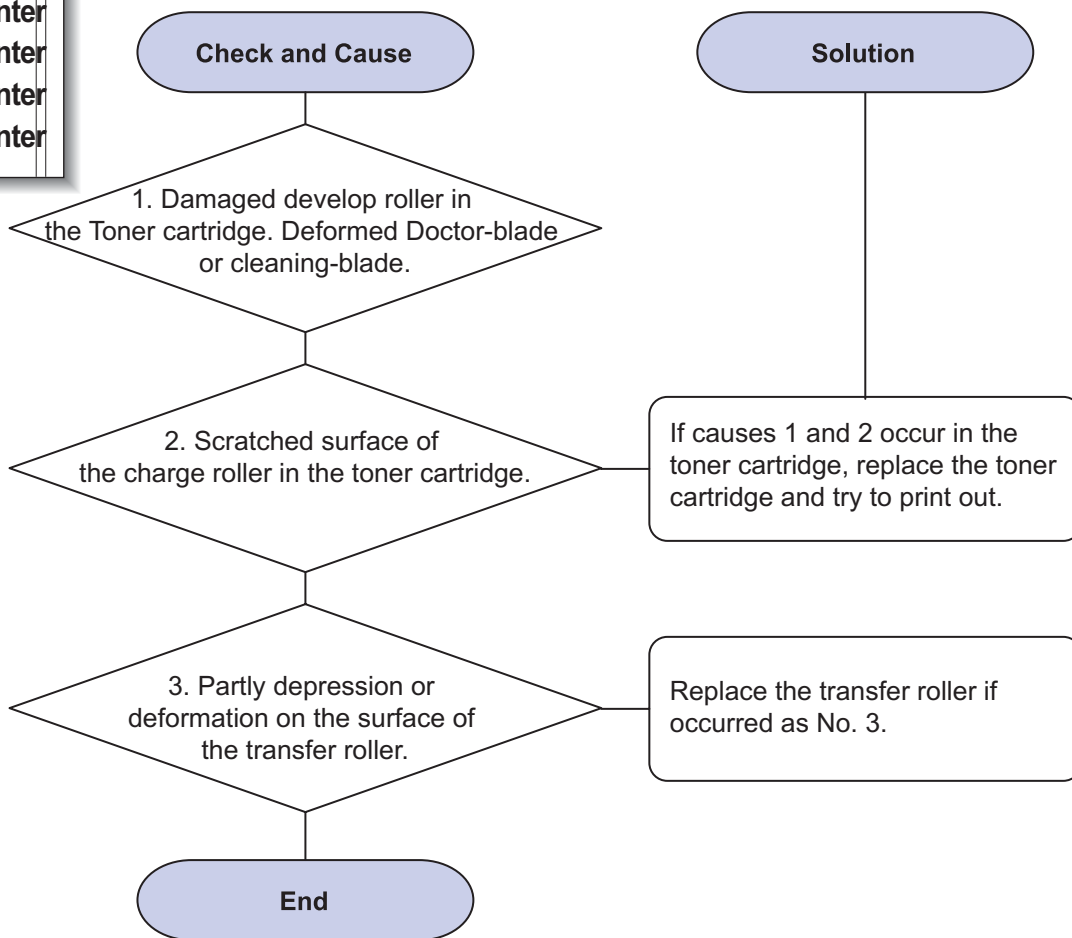
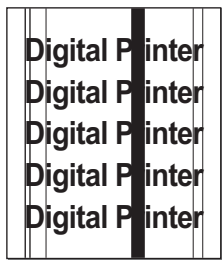

2) Vertical White Line

Description : White vertical voids in the image.

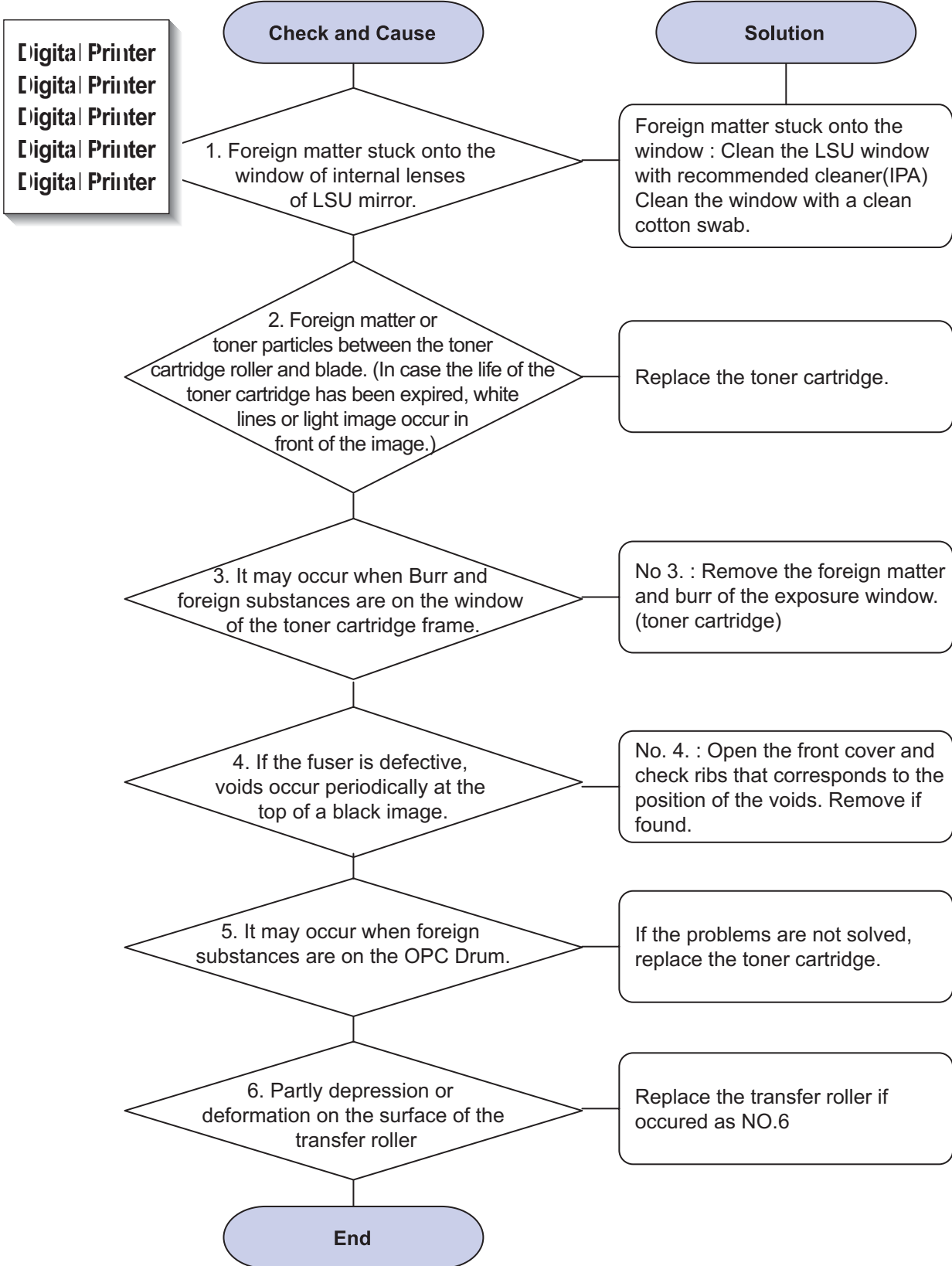

### 3) Horizontal Black Band

Description : Dark or blurry horizontal stripes occur in the printing periodically.  
(They may not occur periodically.)

~~Digital Printer~~  
Digital Printer  
~~Digital Printer~~  
Digital Printer  
~~Digital Printer~~

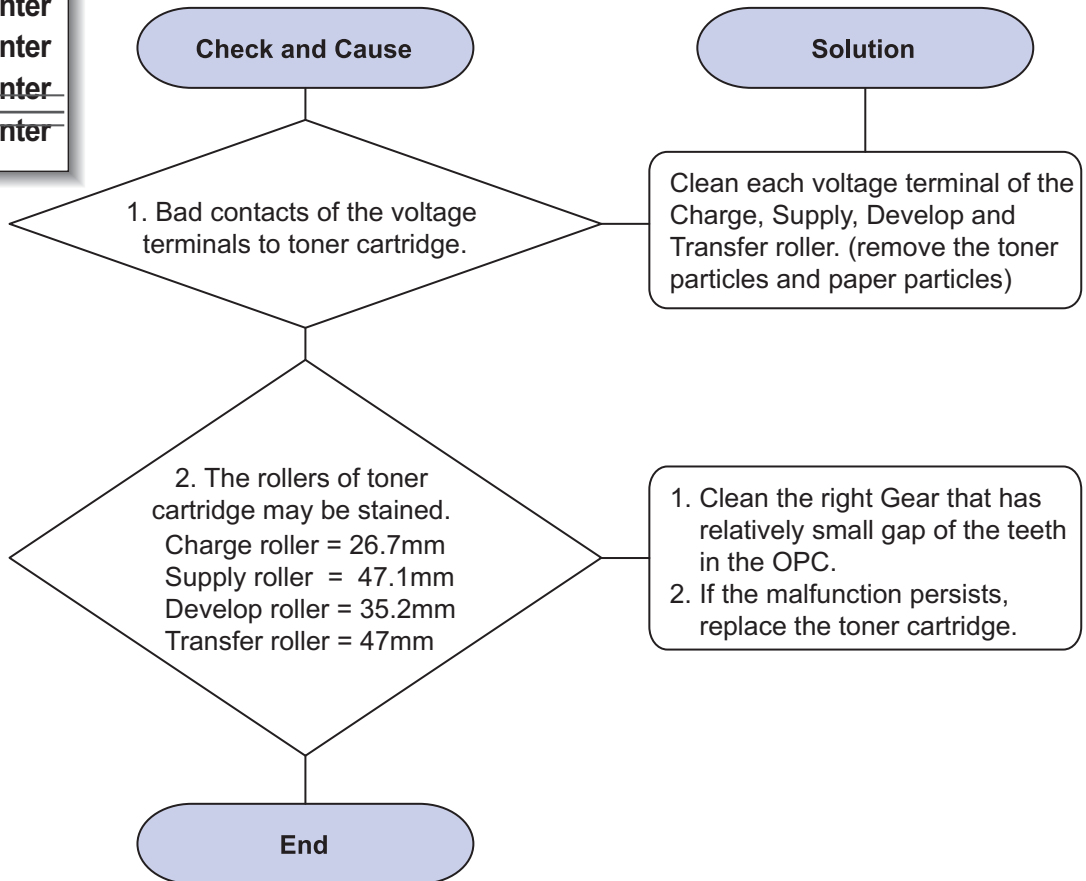

### 4) Black/White Spot

Description : 1. Dark or blurry spots occur periodically in the printing  
 2. White spots occur periodically in the printing

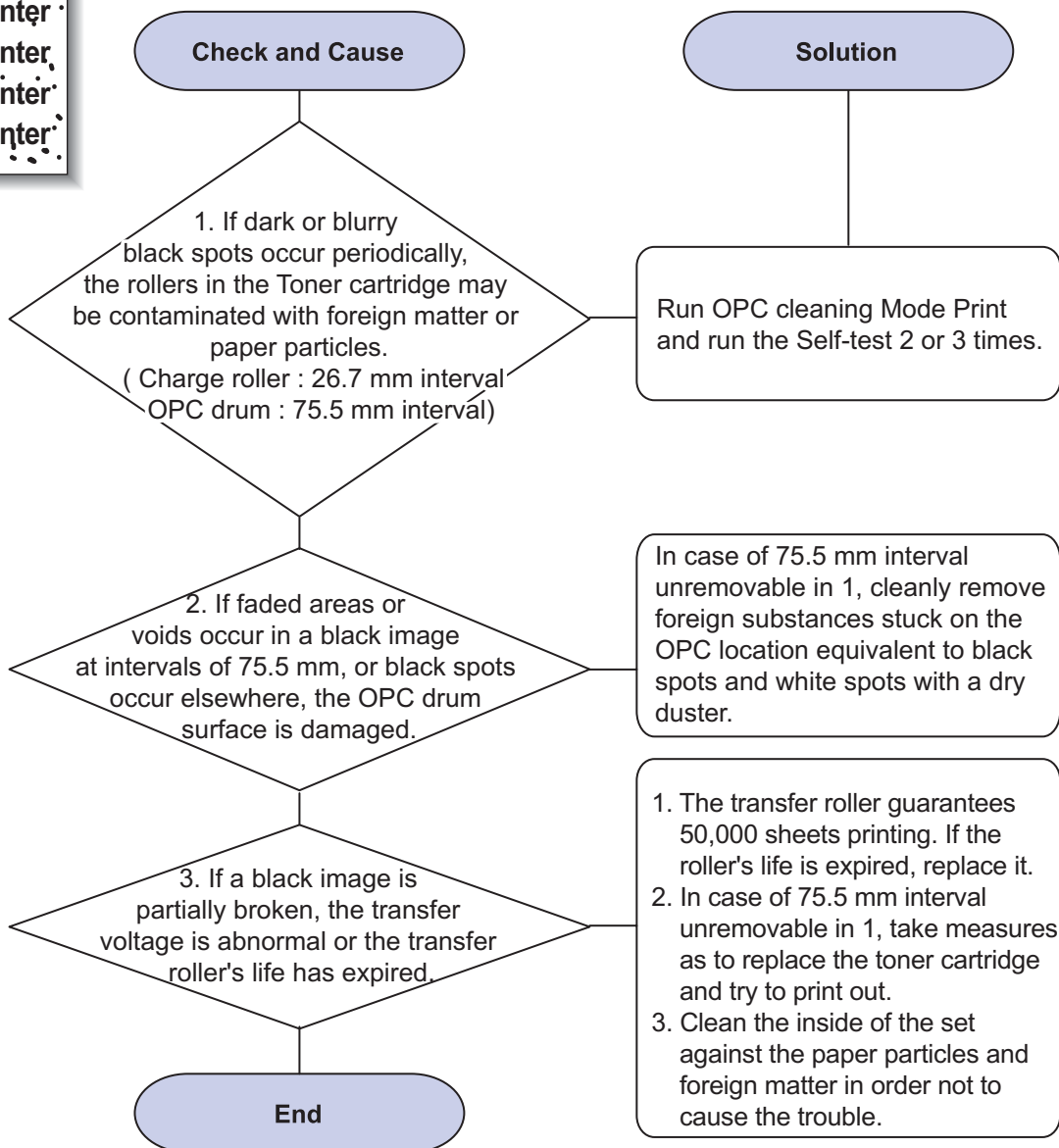

### 5) Light Image

Description : The printed image is light, with no ghost.

Digital Printer  
Digital Printer  
Digital Printer  
Digital Printer  
Digital Printer

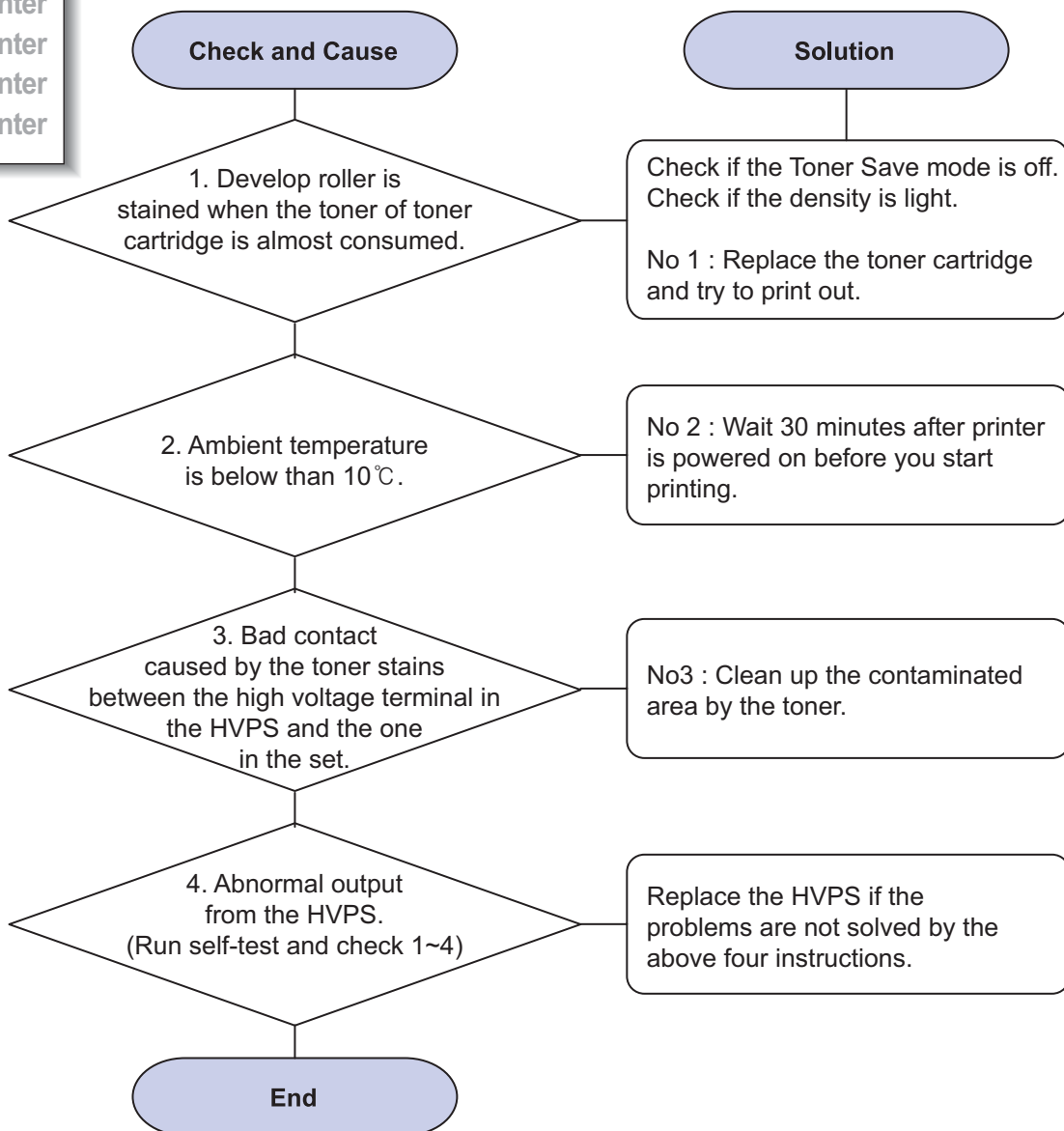

### 6) Dark Image or a Black Page

Description : The printed image is dark.

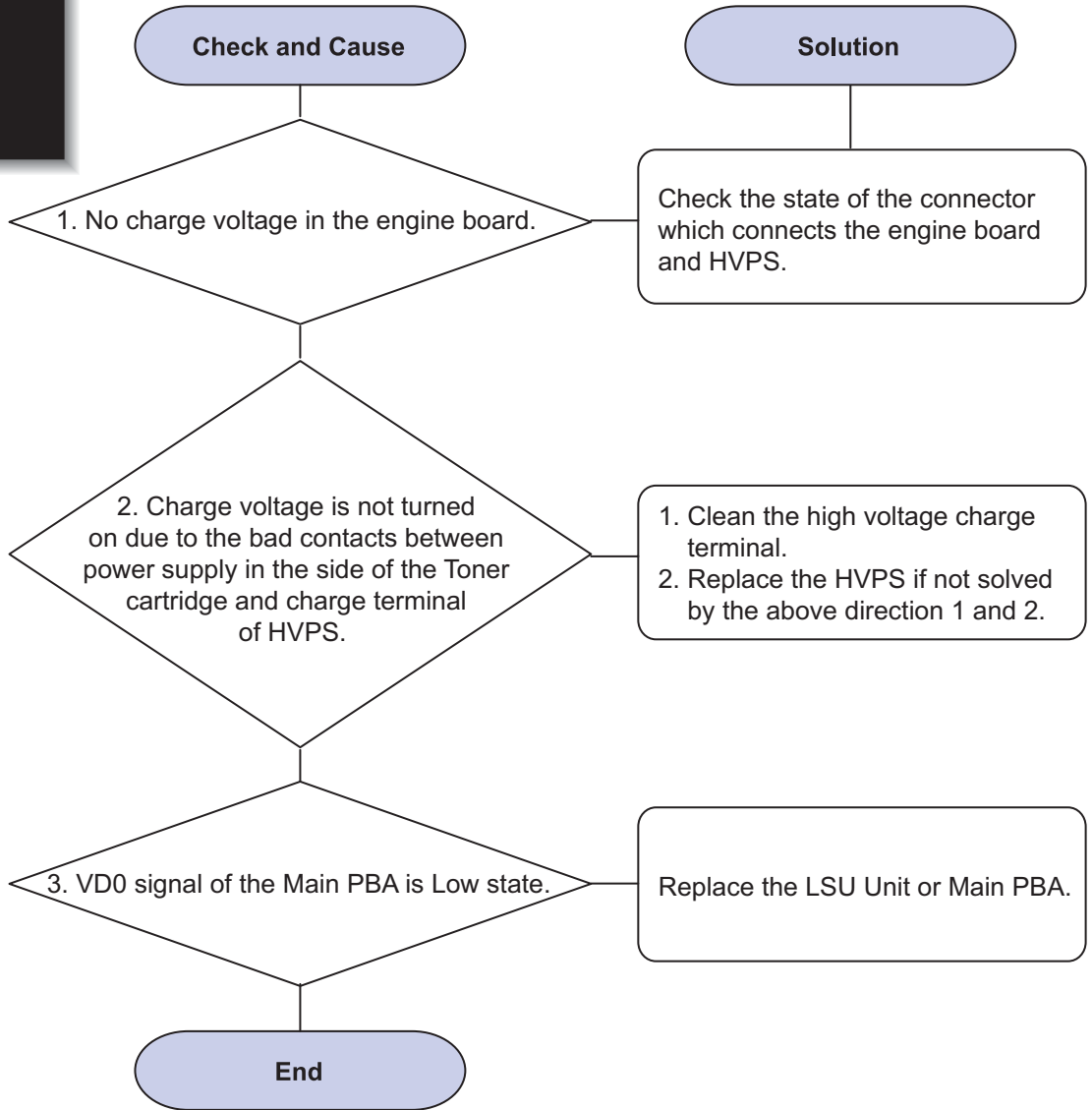
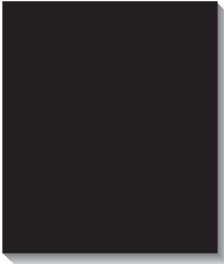

### 7) Uneven Density

Description : Print Density is uneven between left and right.

Digital Printer  
Digital Printer  
Digital Printer  
Digital Printer  
Digital Printer

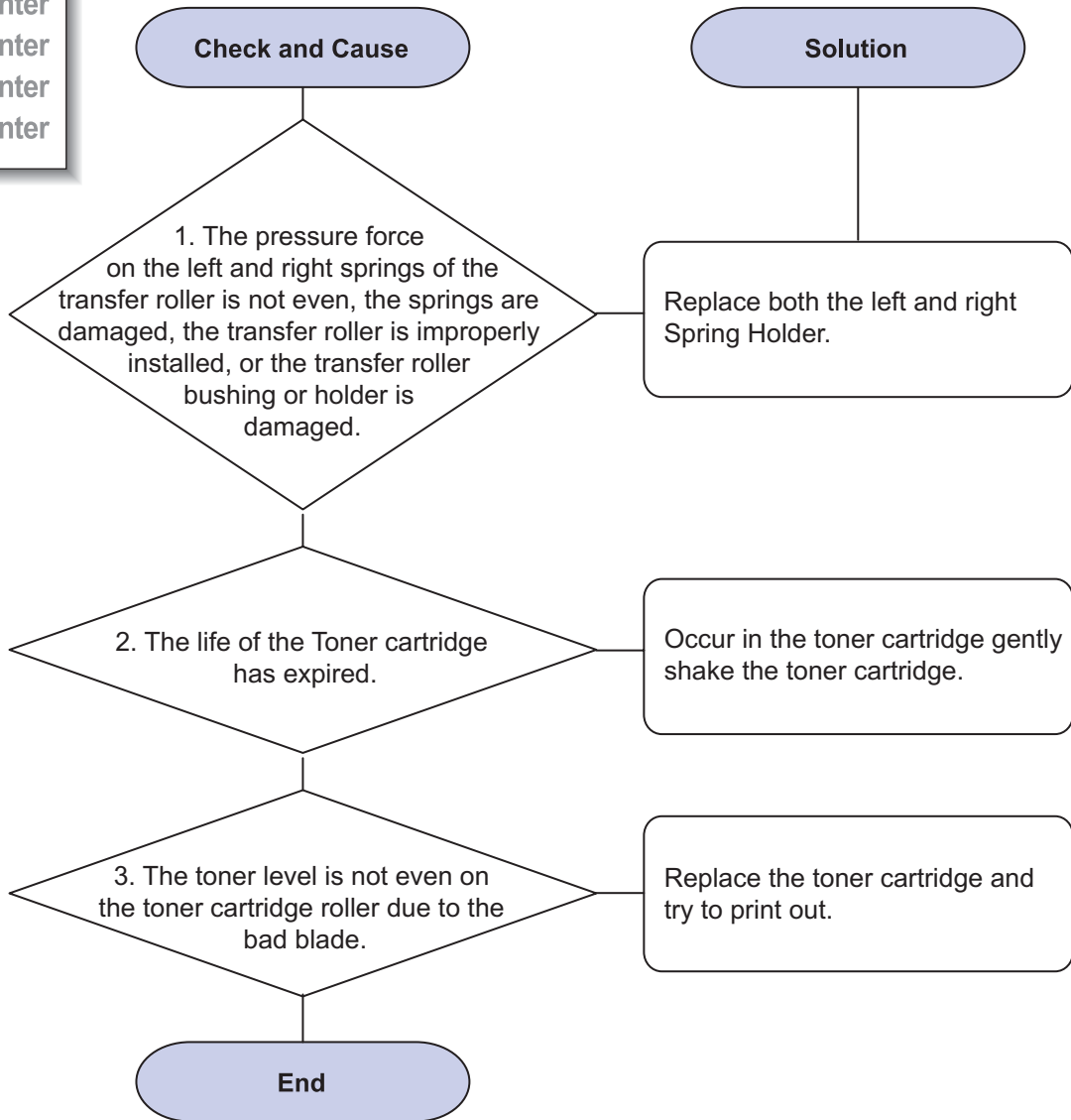

### 8) Background

Description : Light dark background appears in whole area of the printing.

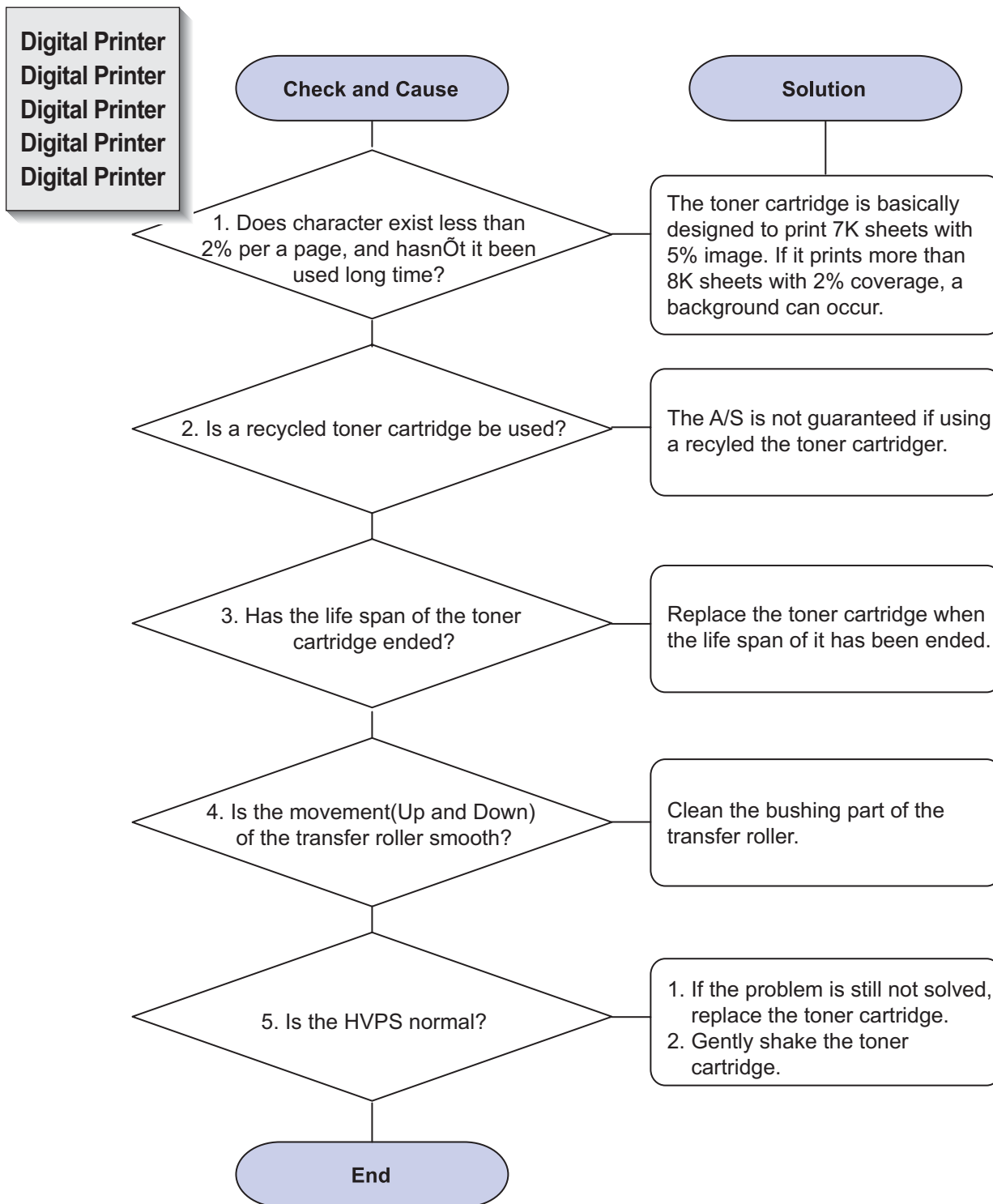



9) Ghost (1)

Description : Ghost occurs at 75.5 mm intervals of the OPC drum in the whole printing.

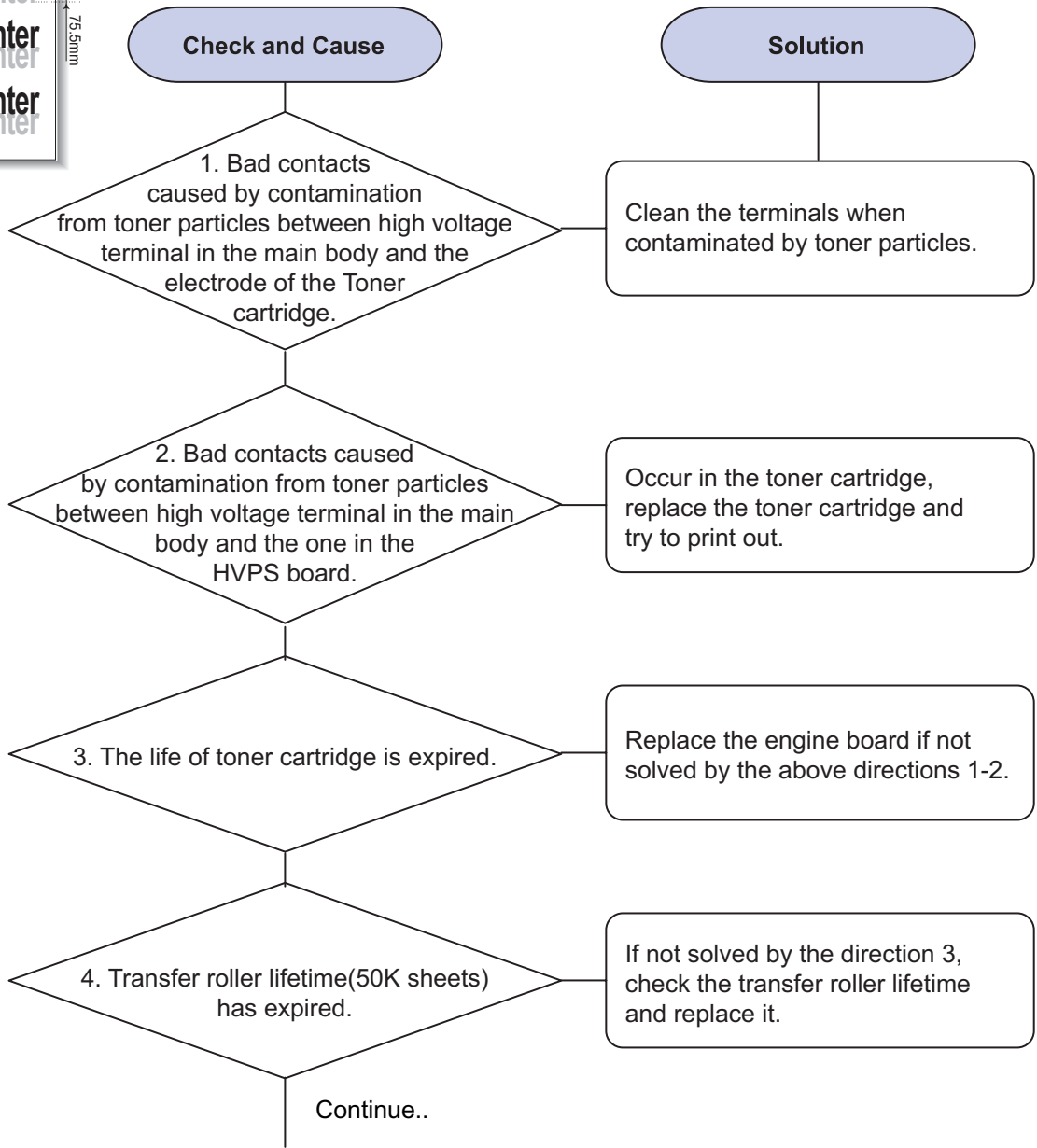

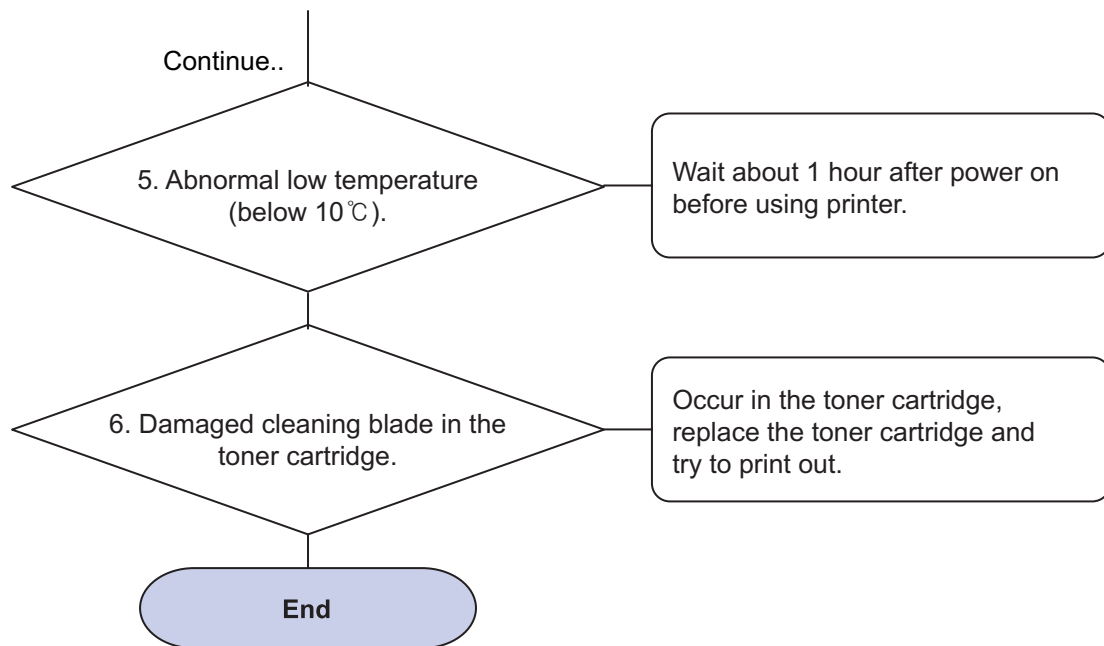

### 10) Ghost (2)

Description : Ghost occurs at 75.5 mm intervals of the OPC drum in the whole printing.  
(When printing on card stock or transparencies using manual feeder)

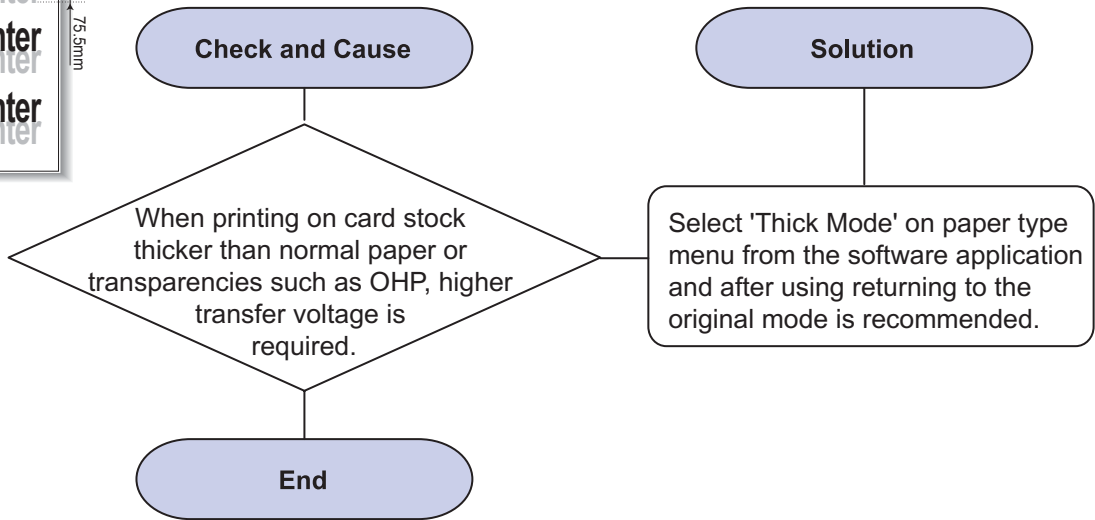

### 11) Ghost (3) : Fuser

Description : Ghost occurs at 62.8 mm or 77.6mm intervals.

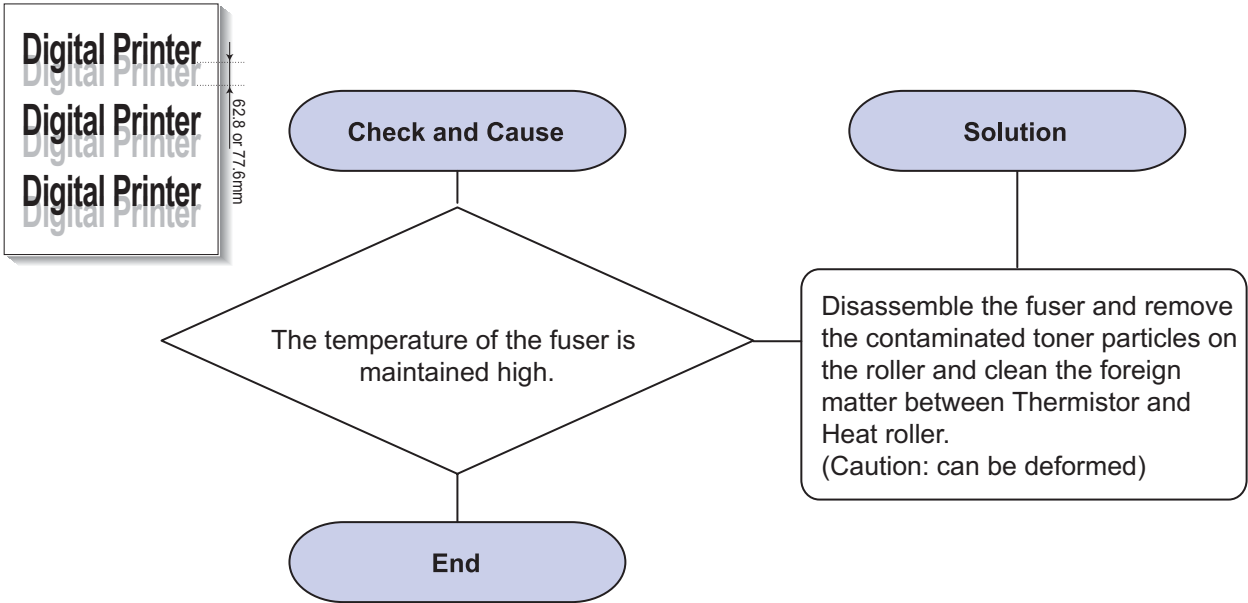

## 12) Stains on the Face of Page

Description : The background on the face of the printed page is stained.

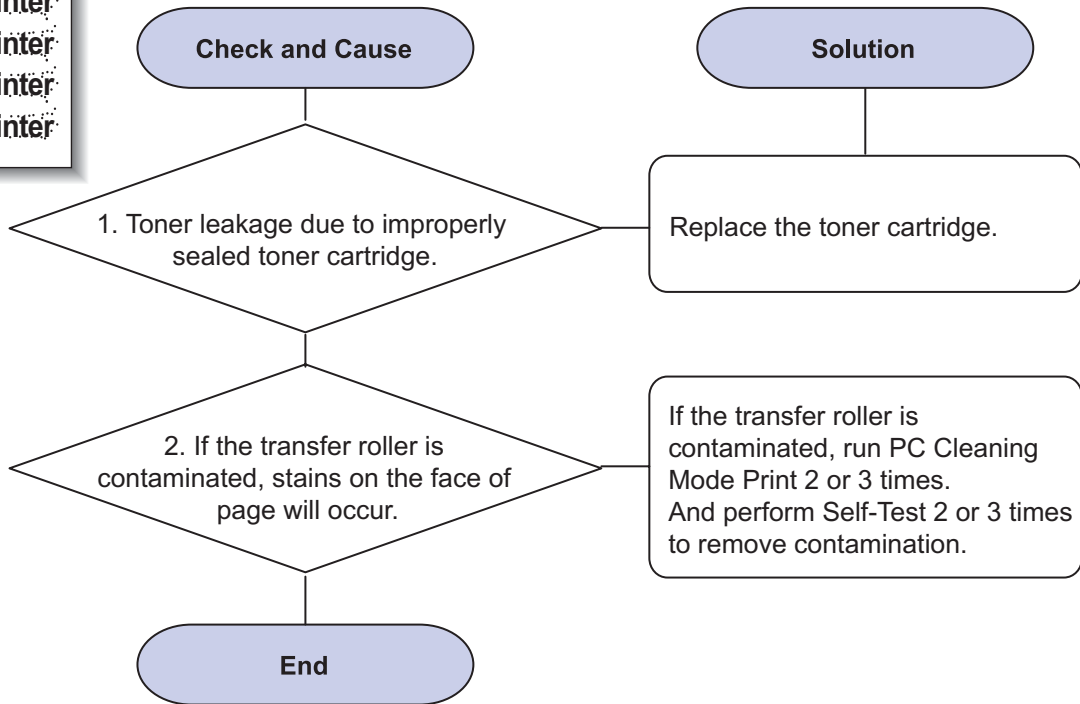

### 13) Stains on Back of Page

Description : The back of the page is stained at 47 mm or 62.8mm intervals.

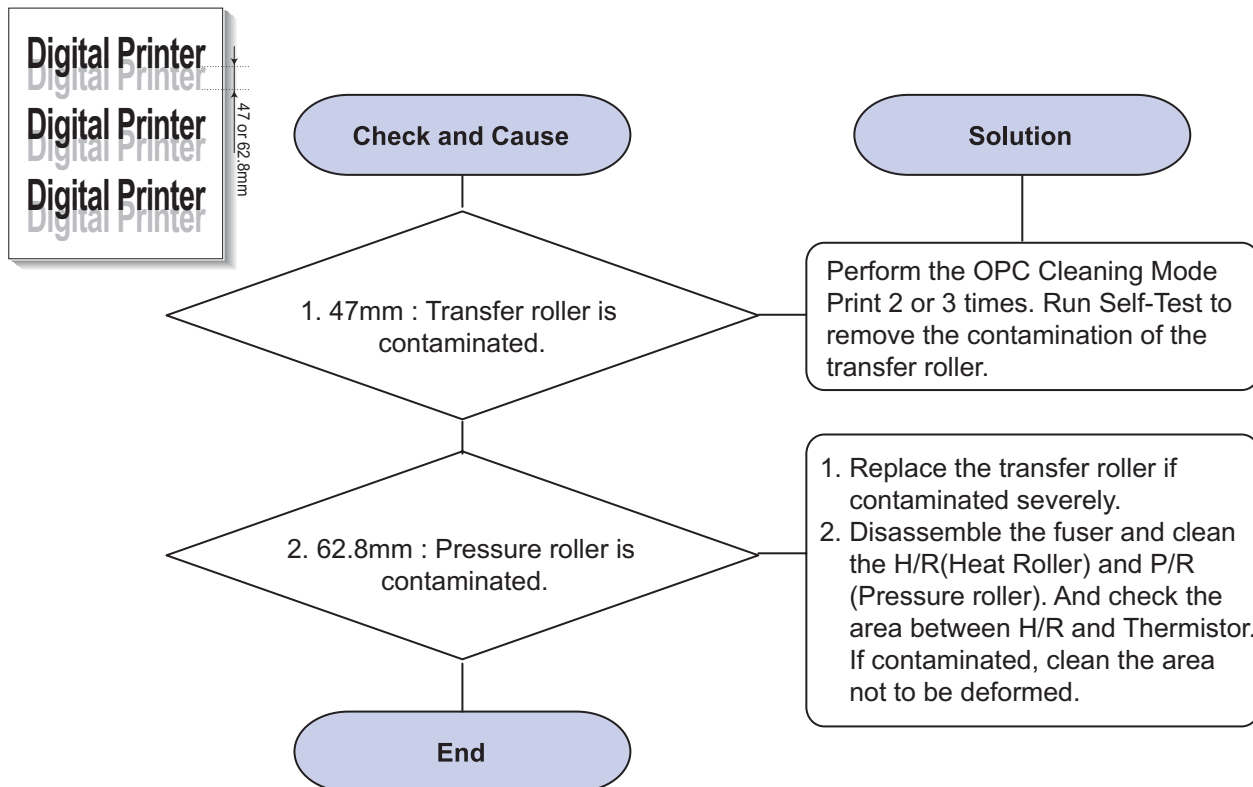

### 14) Blank Page Print out (1)

Description : Blank page is printed.

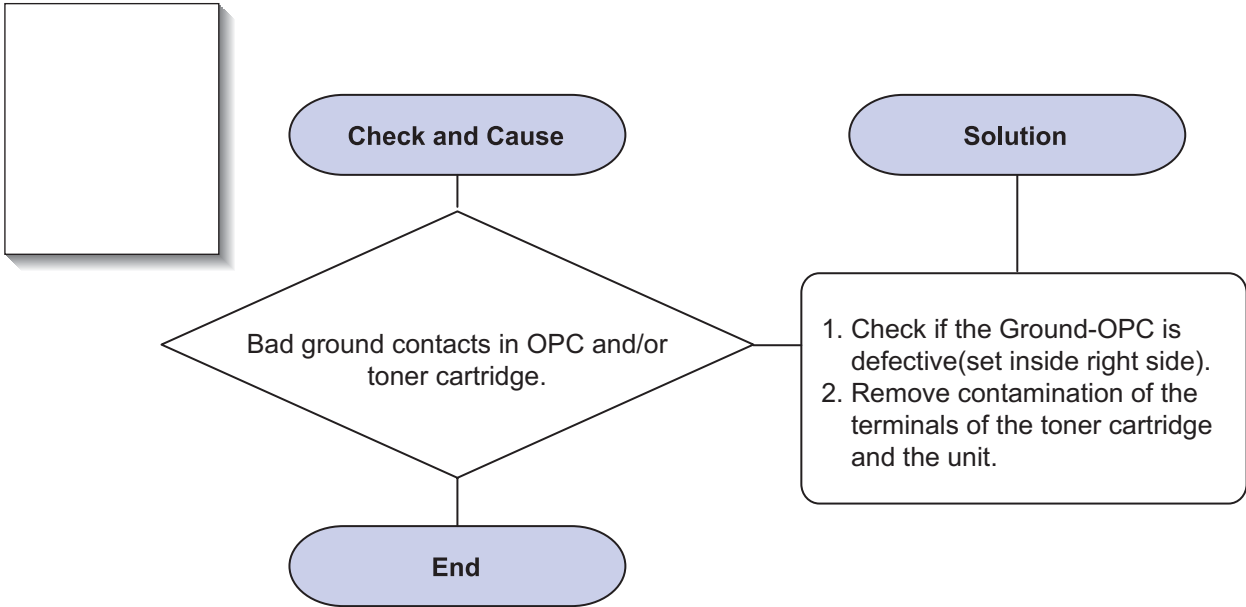

### 15) Blank Page Print out (2)

Description : 1. Blank page is printed.  
 2. One or several blank pages are printed.  
 3. When the printer turns on, several blank pages print.

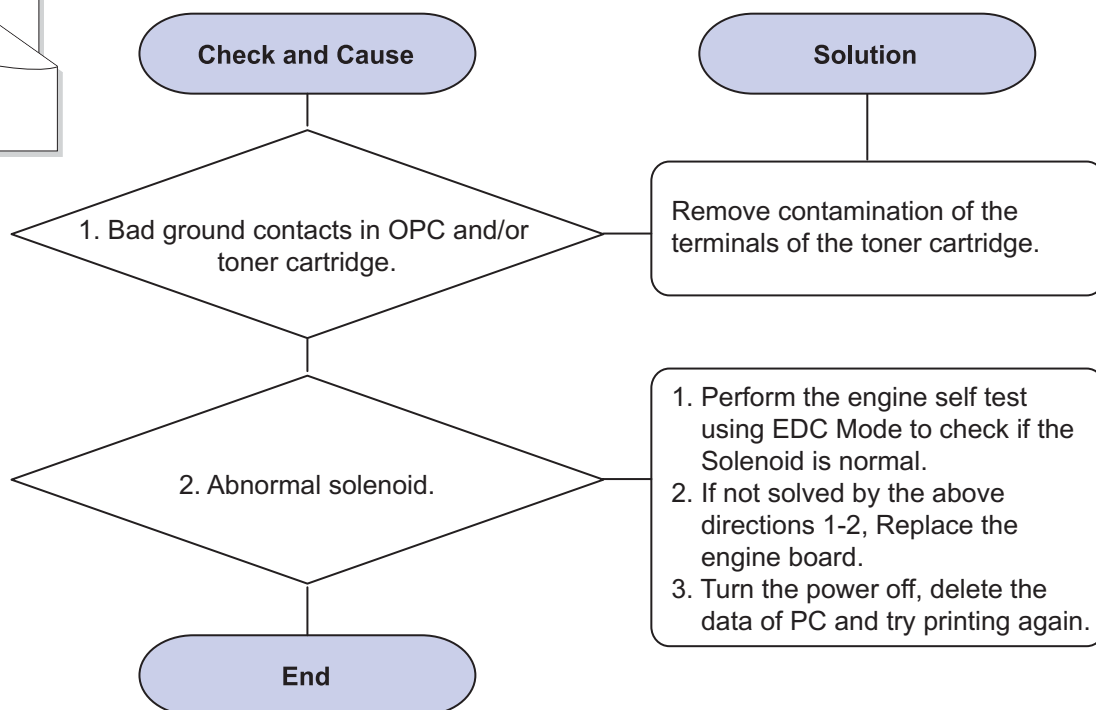
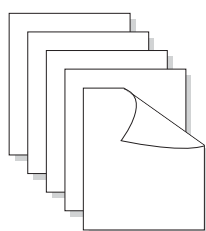



## 4.2.3 The cause and solution of the bad discharge

### 1) Wrong Print Position

Description : Printing begins at wrong position on the paper.

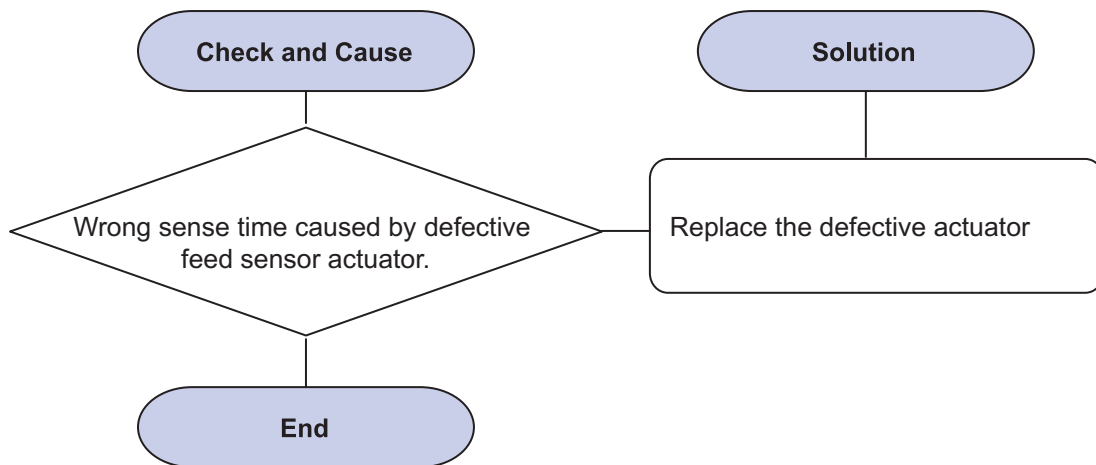

## 2) JAM 0

Description : 1. Paper is not exited from the cassette.  
2. Jam-0 occurs when the paper feeds into the printer

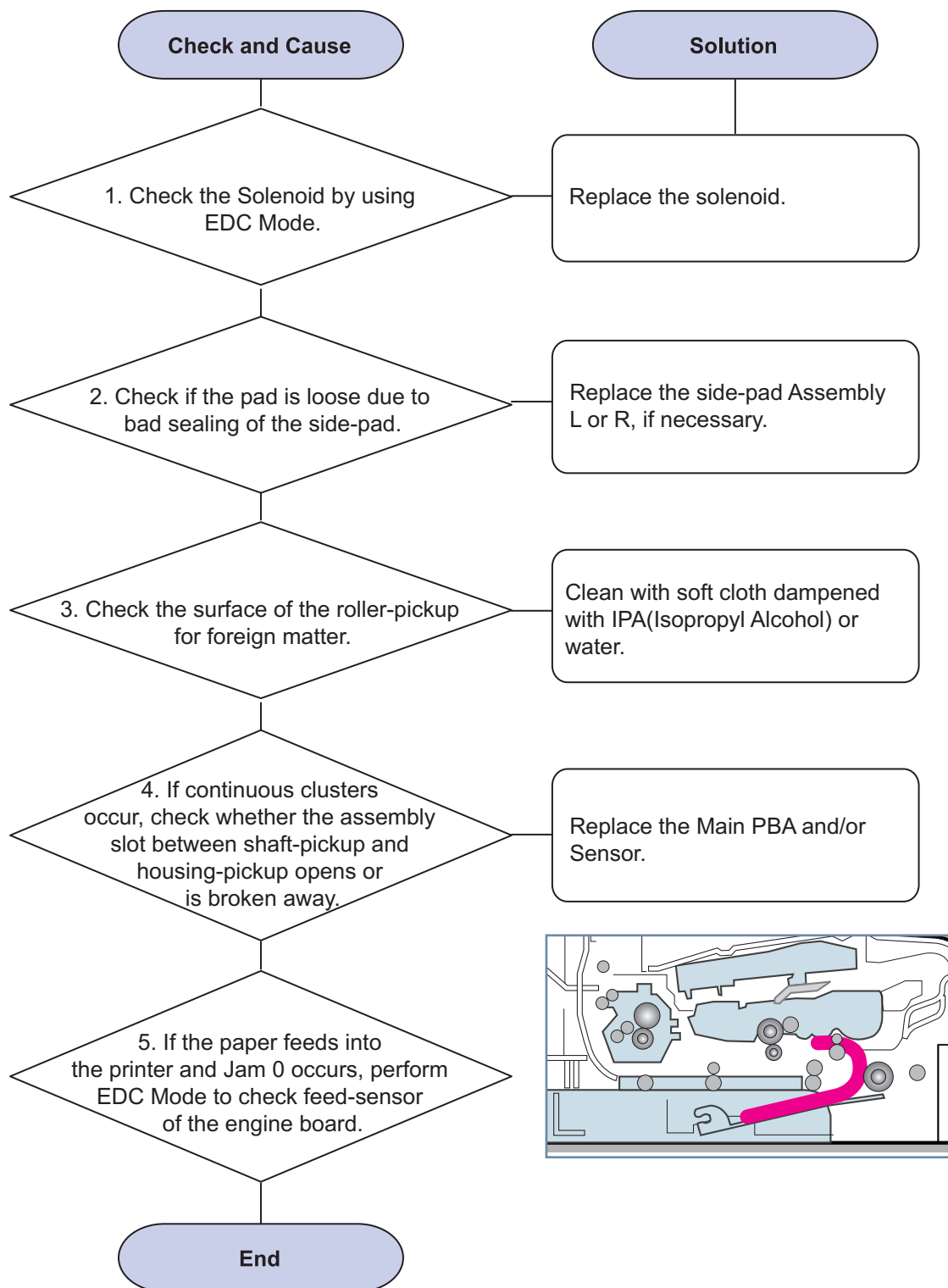

### 3) JAM 1

Description : 1. Recording paper is jammed in front of or inside the fuser.  
 2. Recording paper is stuck in the discharge roller and in the fuser just after passing through the Actuator-Feed.

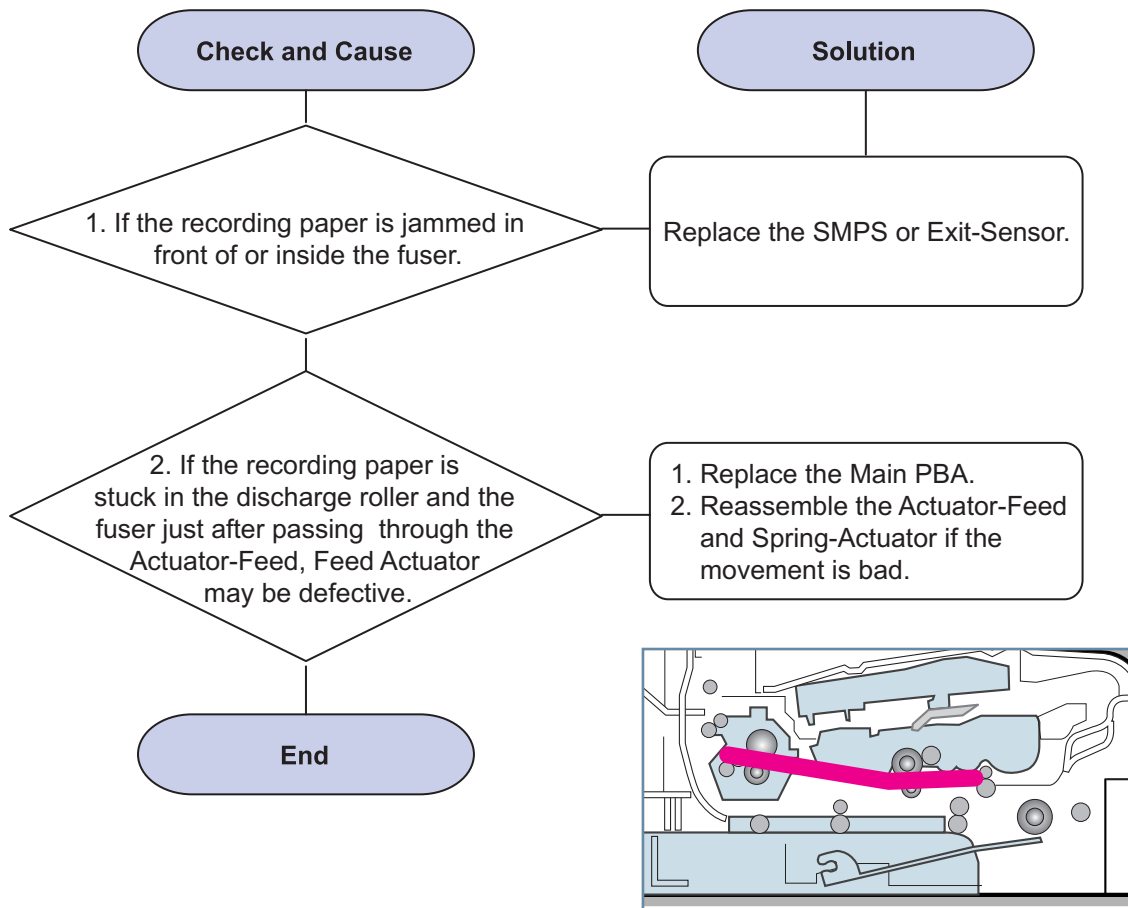

### 4) JAM 2

**Description :** 1. Recording paper is jammed in front of or inside the fuser.  
 2. Recording paper is stuck in the discharge roller and in the fuser just after passing through the Actuator-Feed.

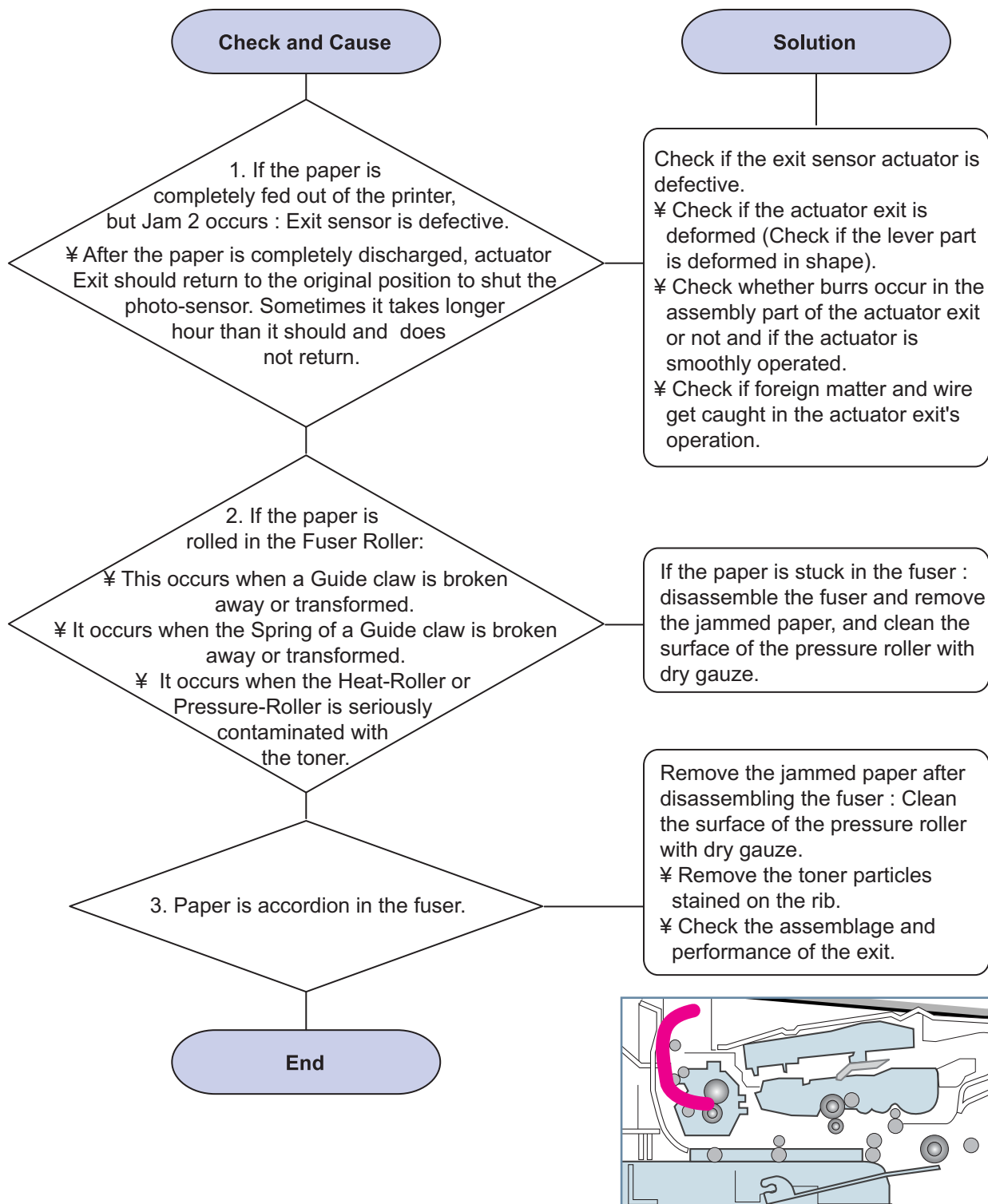

### 5) JAM Duplex

Description : Recording paper is Jammed in front or inside a duplex module.

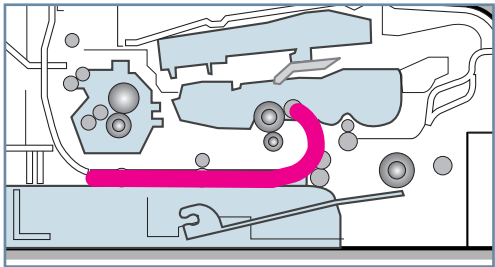
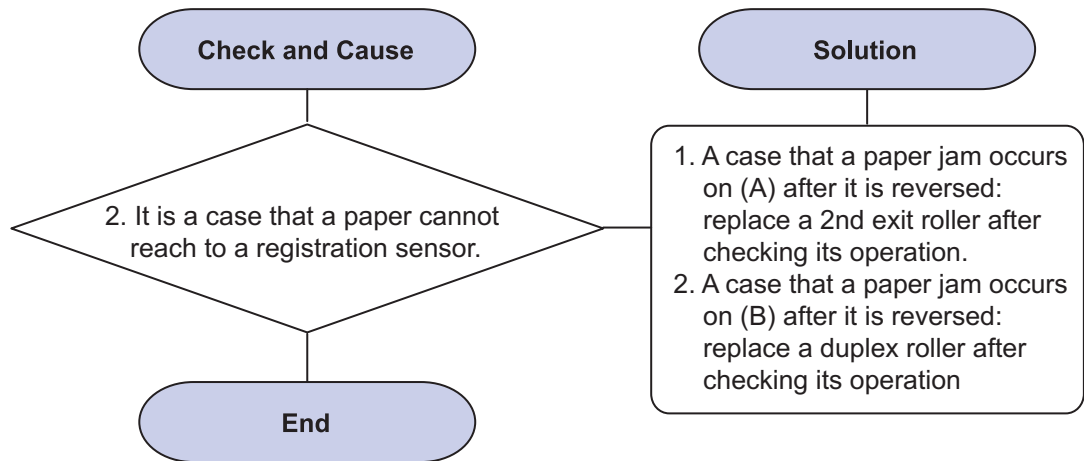

## 6) Multi-Feeding

Description : Multiple sheets of paper are fed at once.

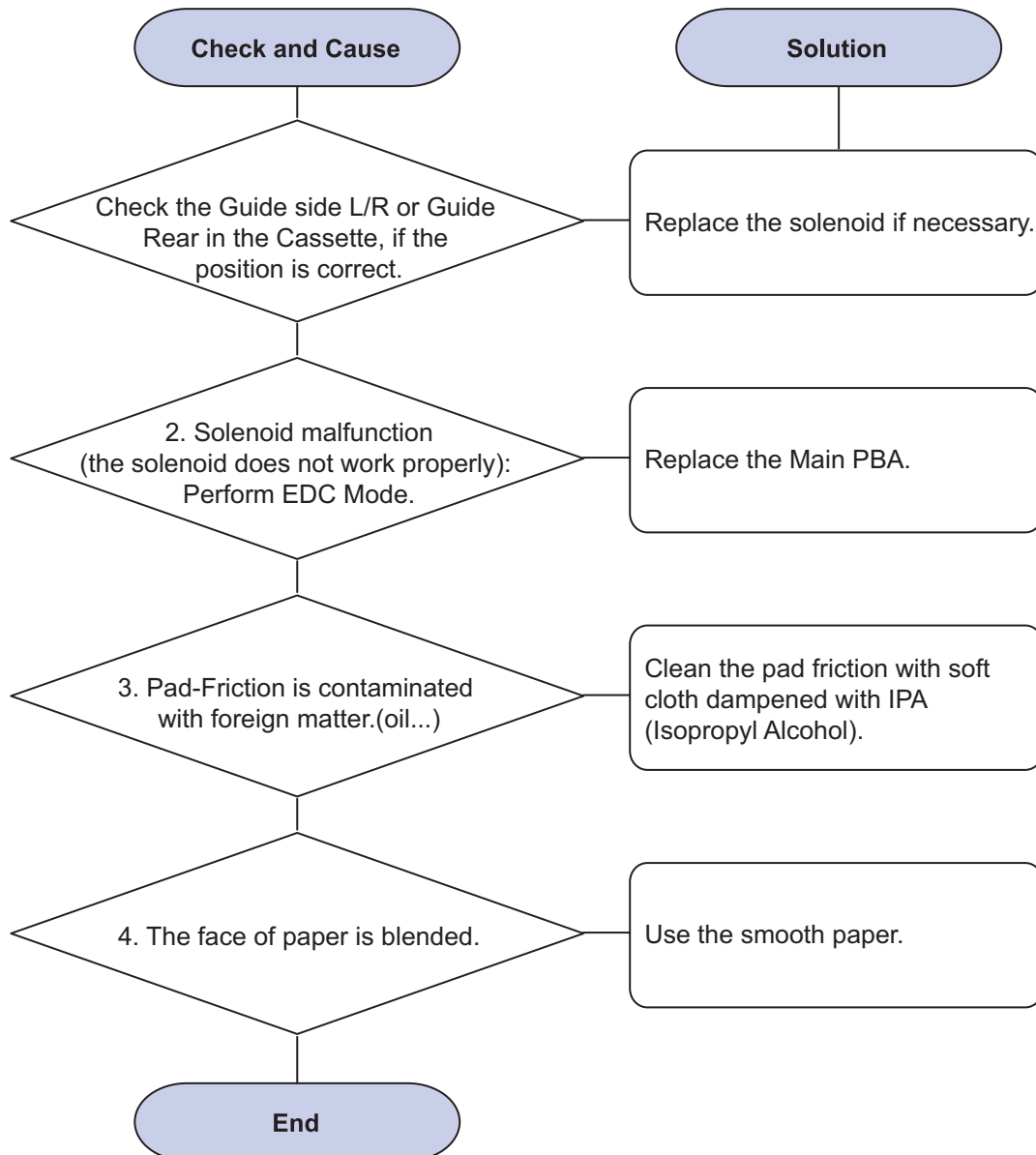

### 7) Paper rolled in the fuser

Description : If contaminated at intervals of 77.6mm on the back of a paper.

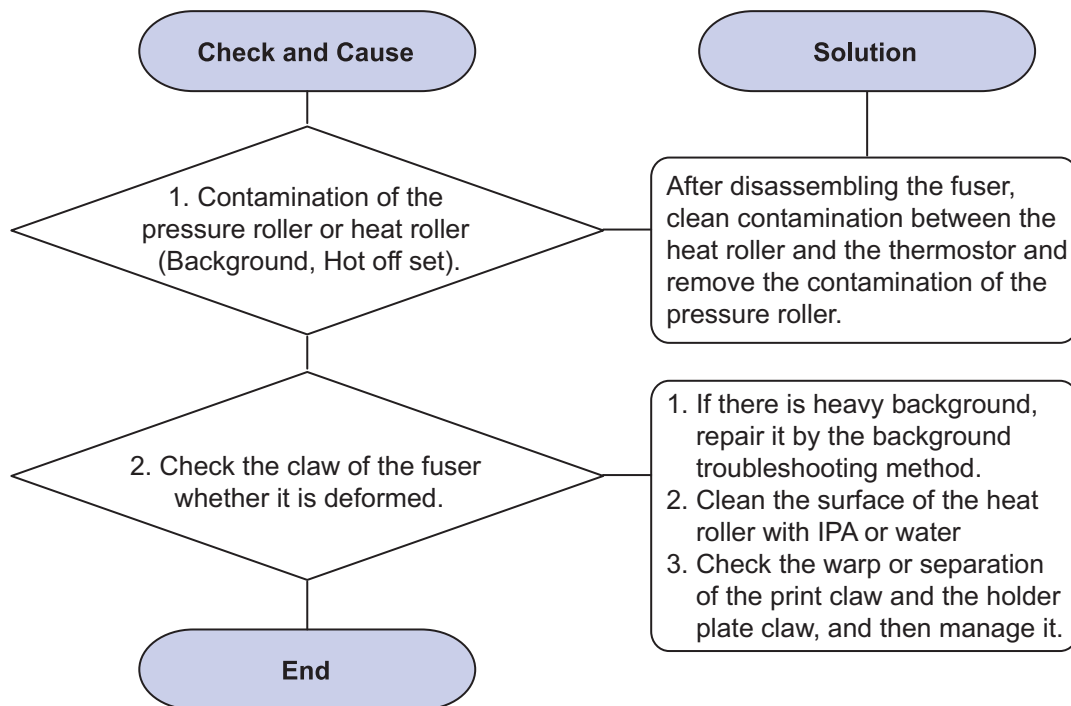

### 8) Paper rolled on the OPC Drum

Description : Paper is rolled up in the OPC.

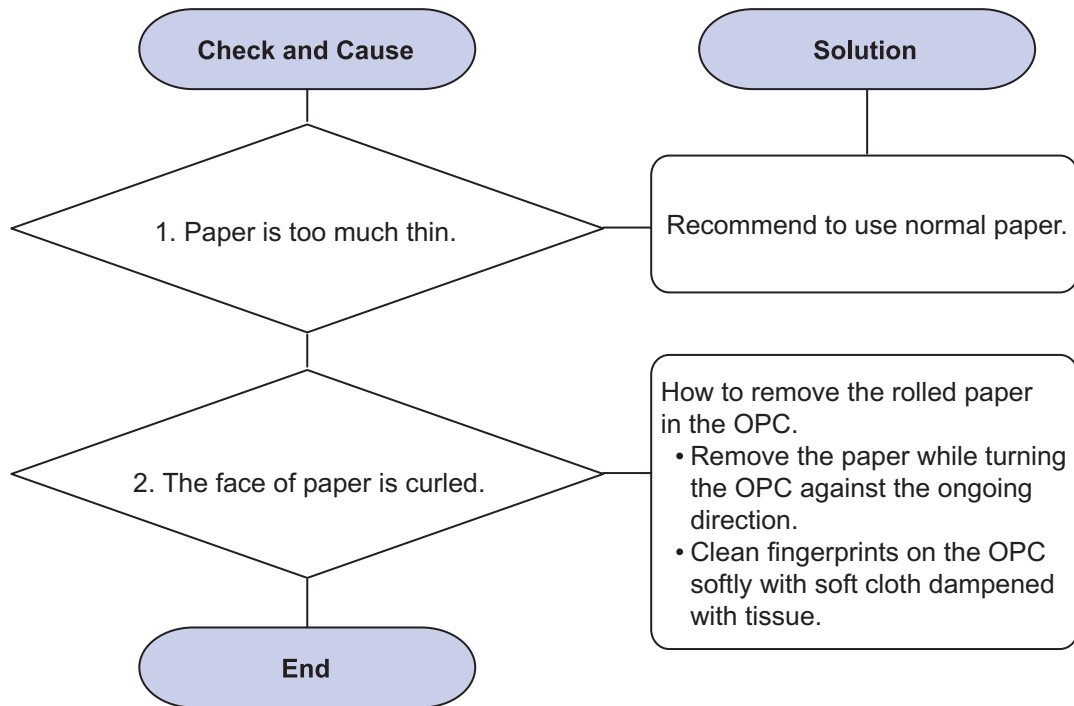



## 4.2.4 The cause and solution of the malfunction

### 1) Fuser Error

Description : Fuser error is displayed on LCD

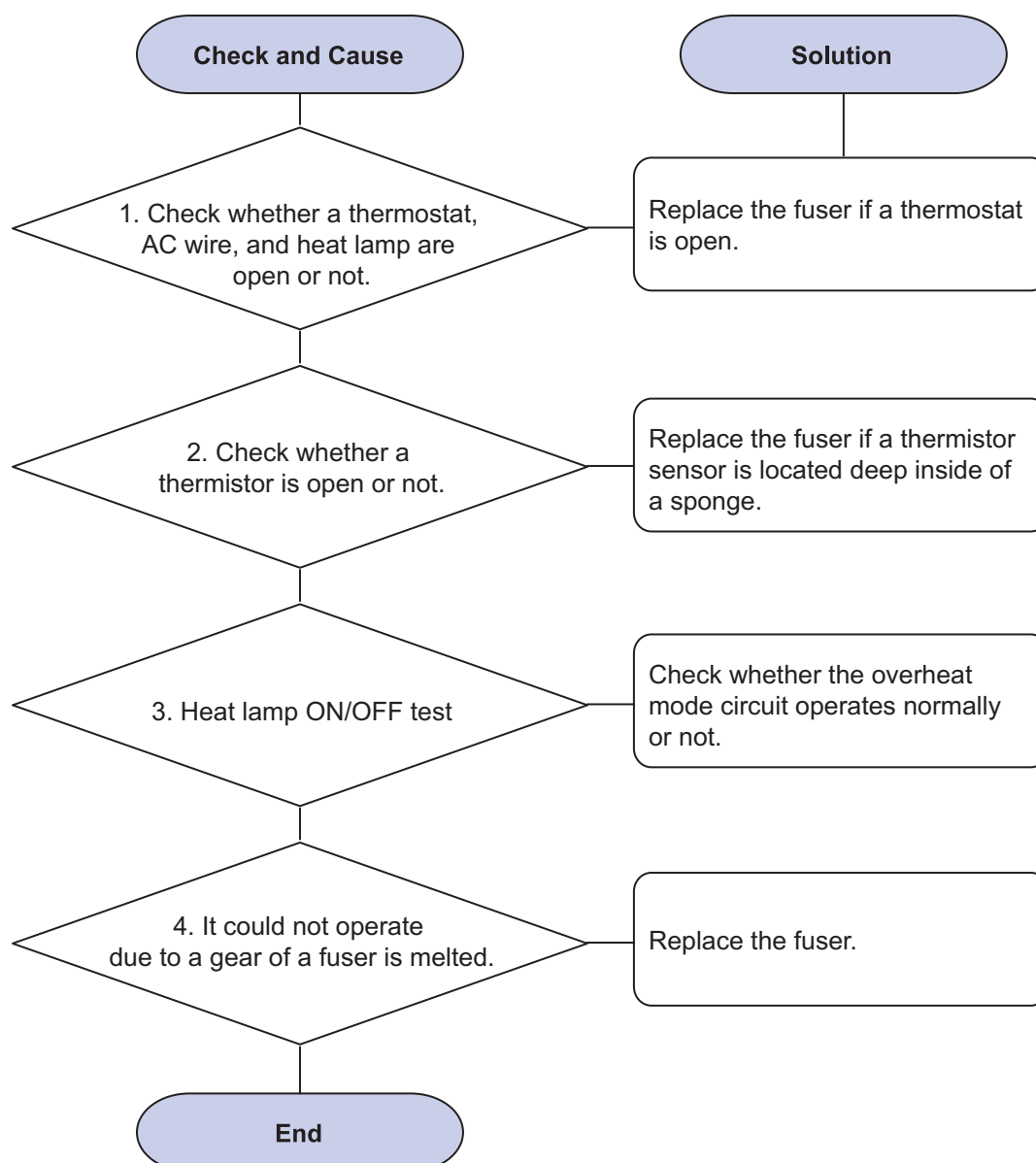

## 2) LSU Error

Description : "PMOTOR ERROR/HSYNC ERROR"

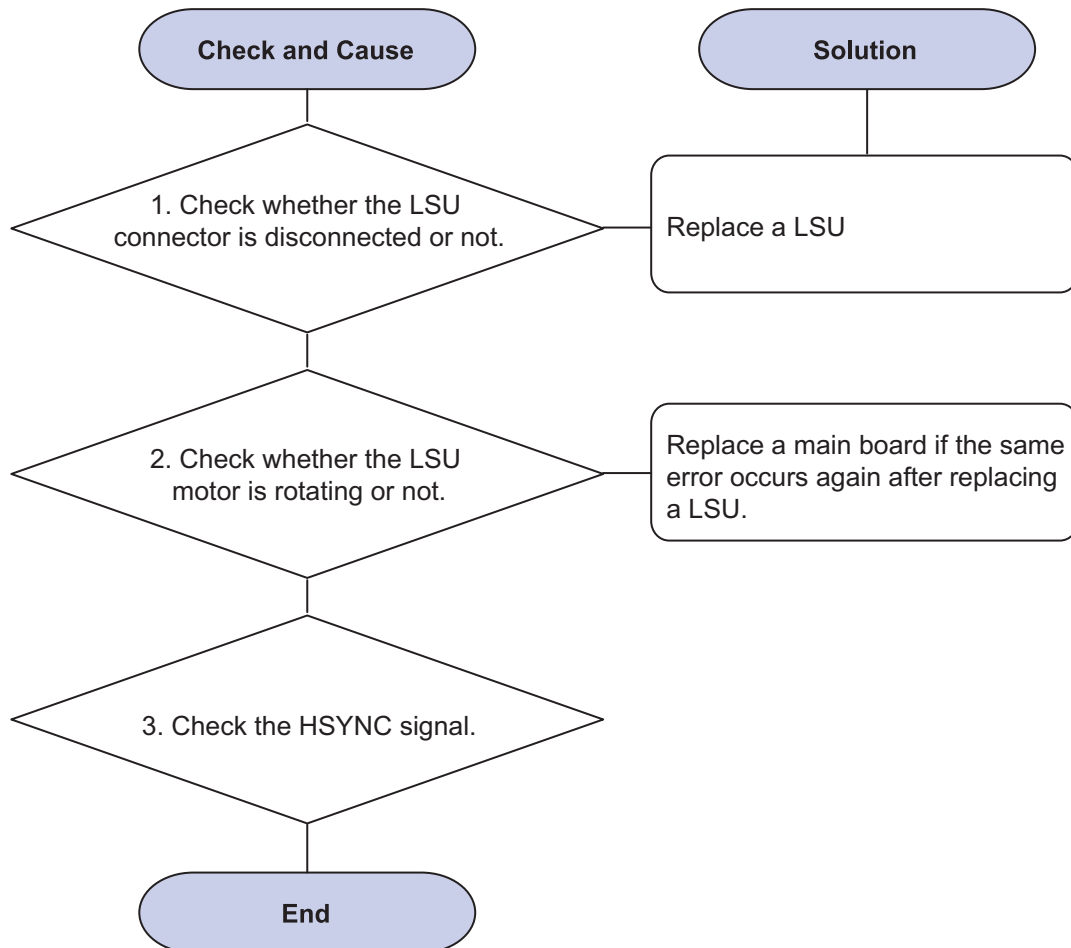

### 3) Not function of the gear of the fuser due to melting away

Description : The motor breaks away from its place due to gear melting away.

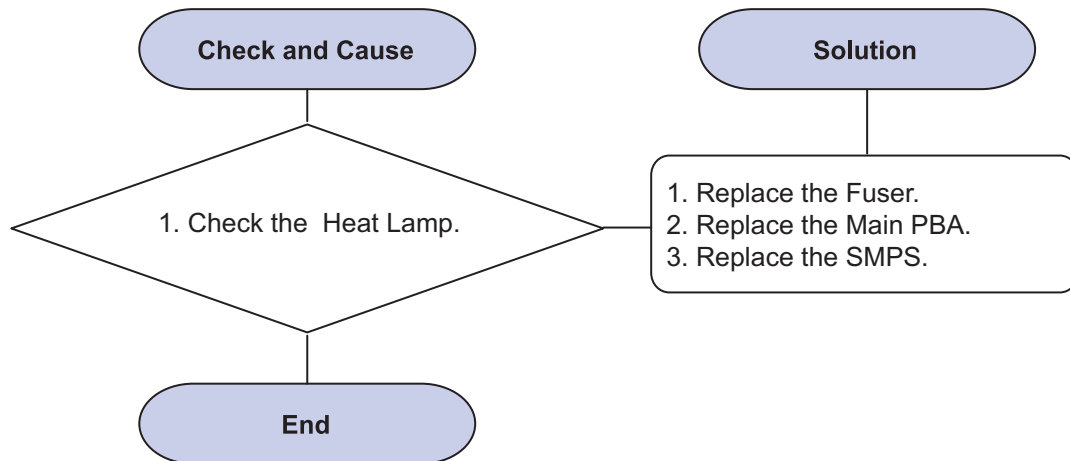

#### 4) Paper Empty

Description : Paper empty error message is displayed on LCD when paper is loaded in the cassette.

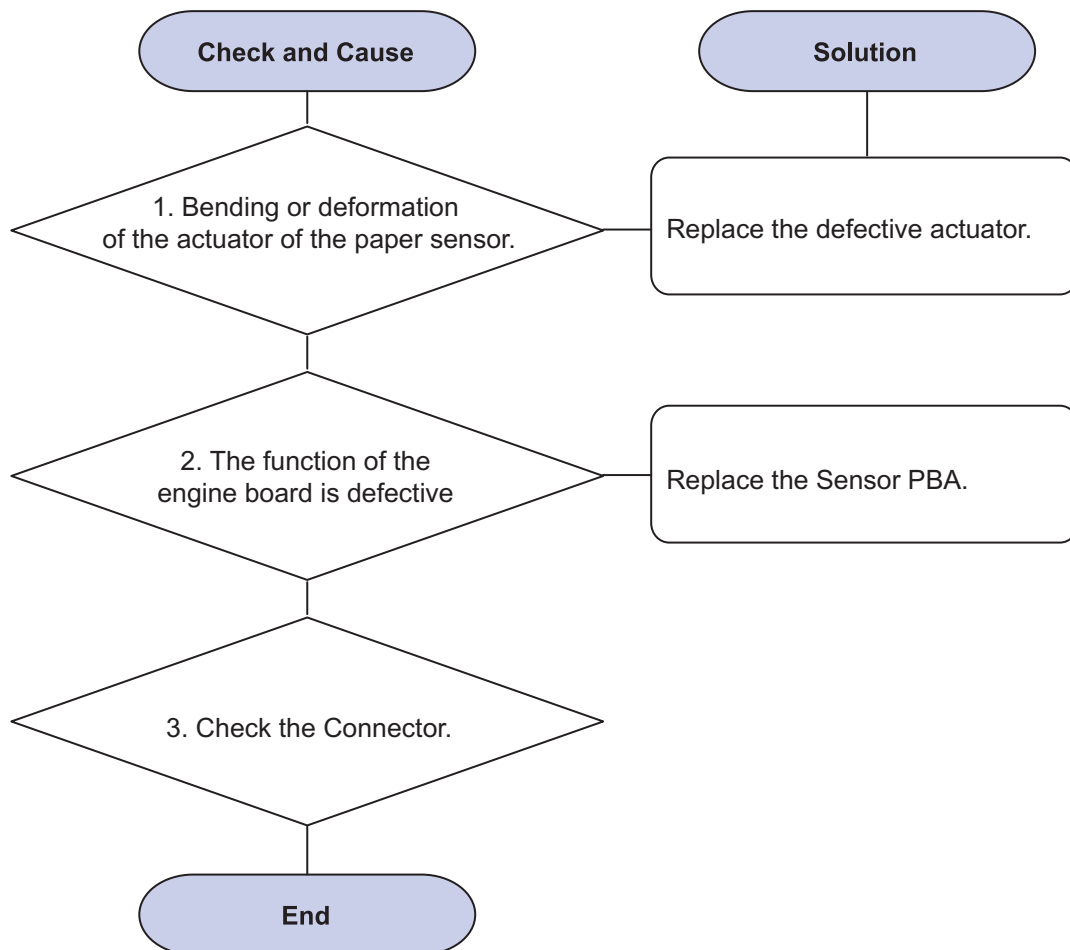

### 5) Paper Empty without indication

Description : Paper empty error message does not display when the paper cassette is empty.

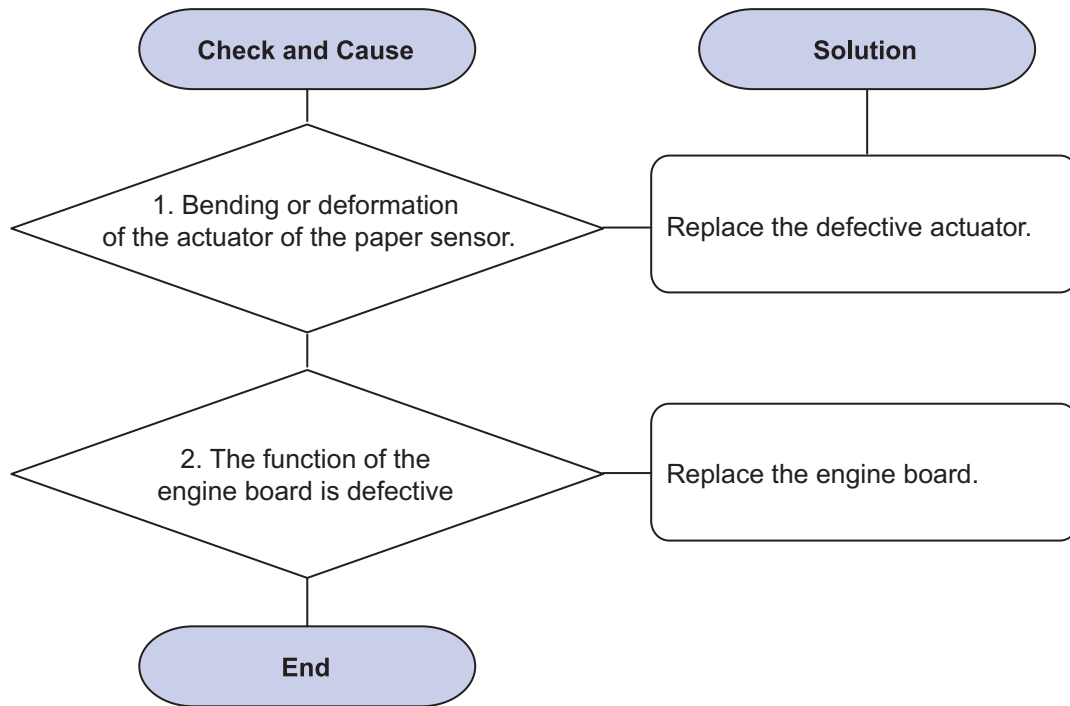

## 6) Cover Open

Description : The ERROR lamp is on even when the print cover is closed.

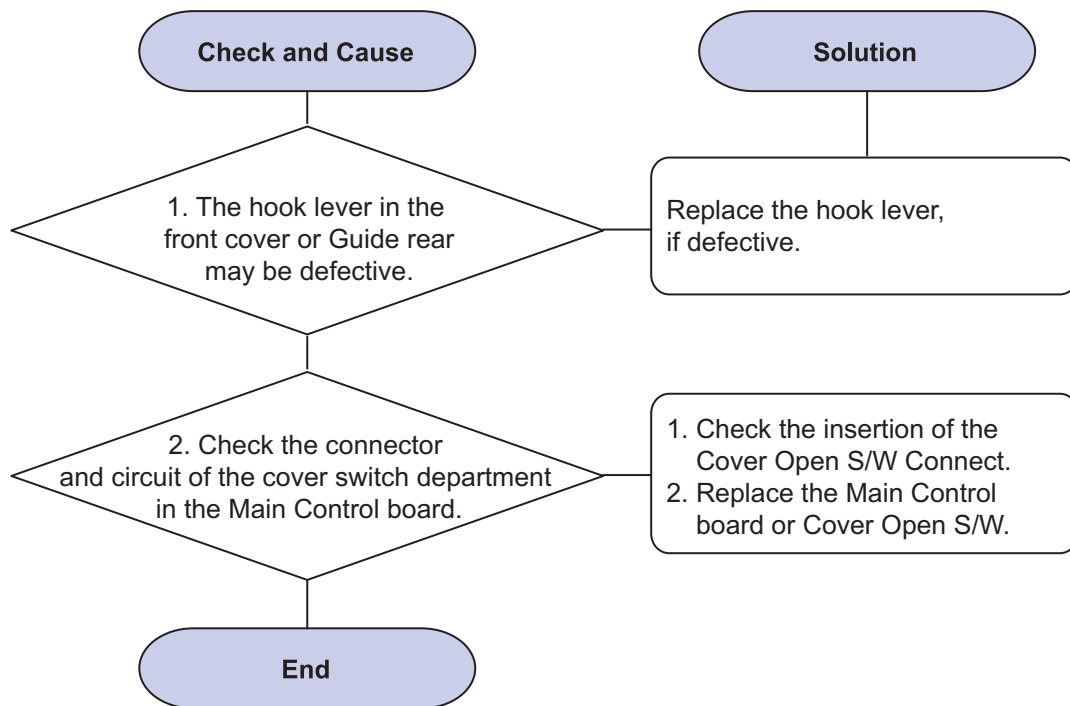

### 7) No error LED when the cover is open

Description : The Error LED does not come on even when the printer cover is open

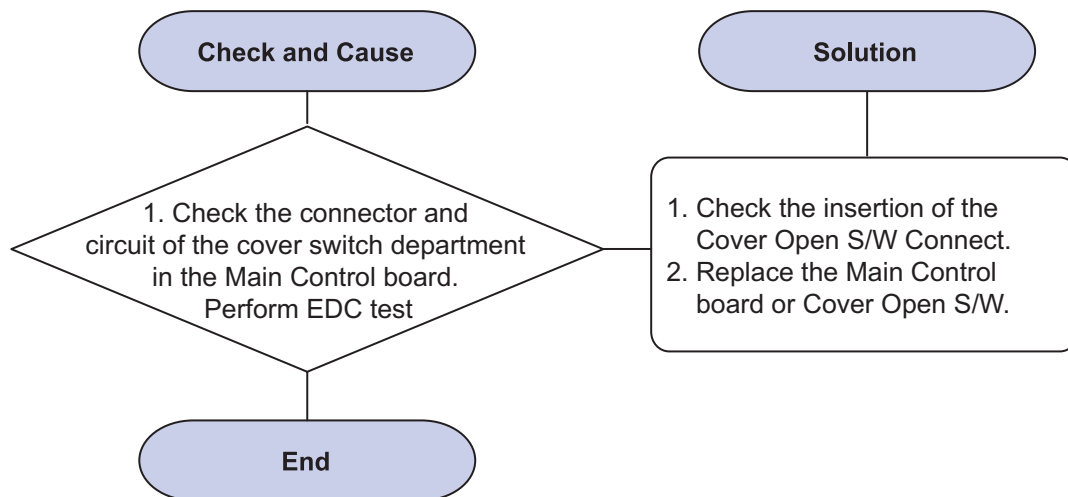

### 8) No Power

Description : When system power is turned on, all lamps on the operator panel do not come on.

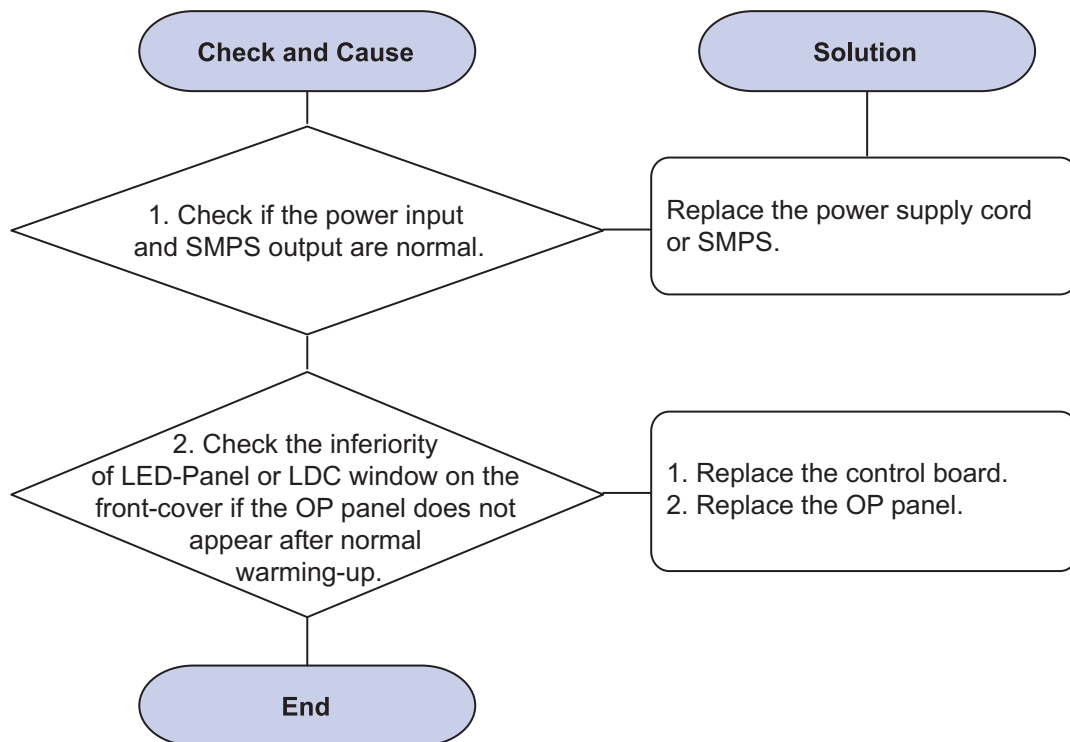



### 9) Vertical Line Getting Curved

Description : When printing, vertical line gets curved.

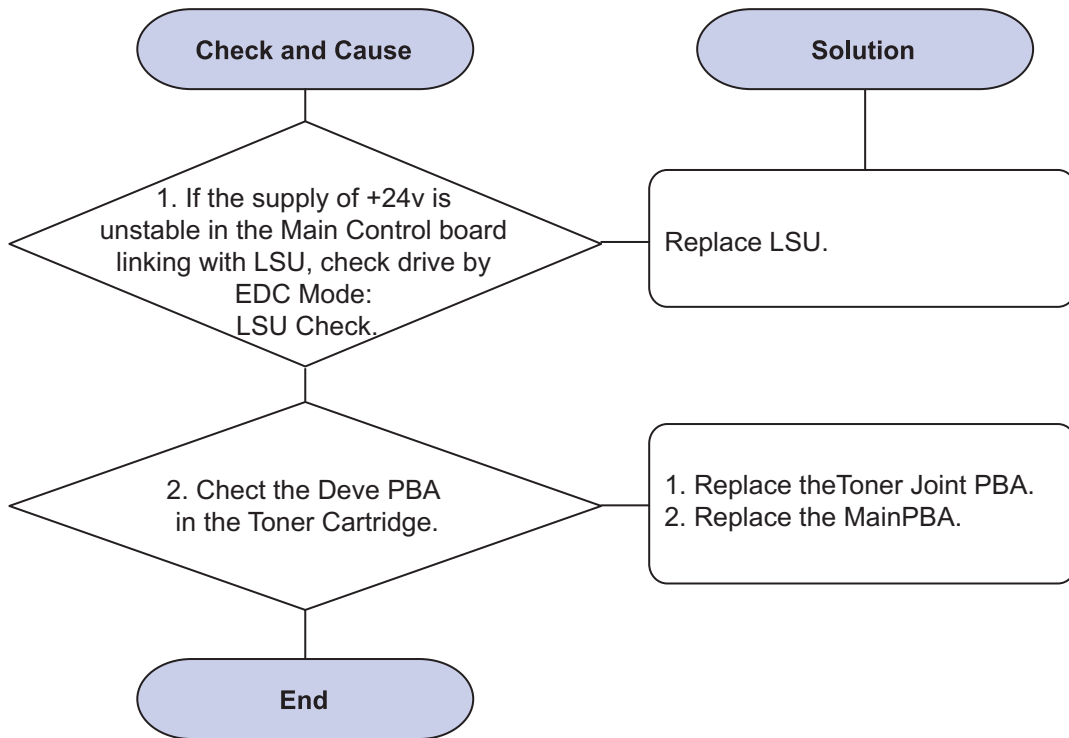

## 4.2.5 The cause and solutions of bad environment of the software

### 1) The printer is not working (1)

Description : While Power turned on, the printer is not working in the printing mode.

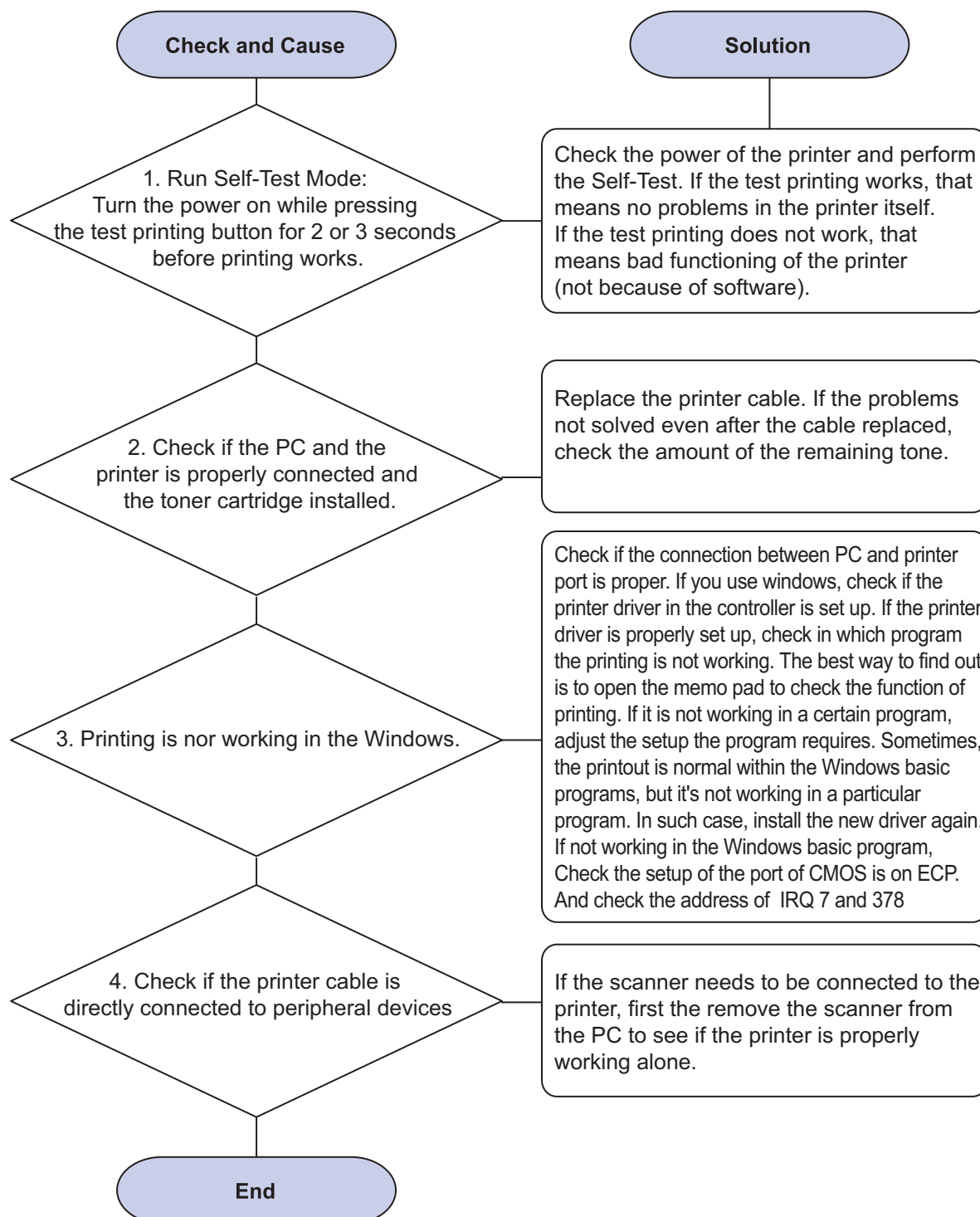

## 2) The printer is not working (2)

Description : After receiving the printing order, no response at all or the low speed of printing occurs due to wrong setup of the environment rather than malfunction of the printer itself.

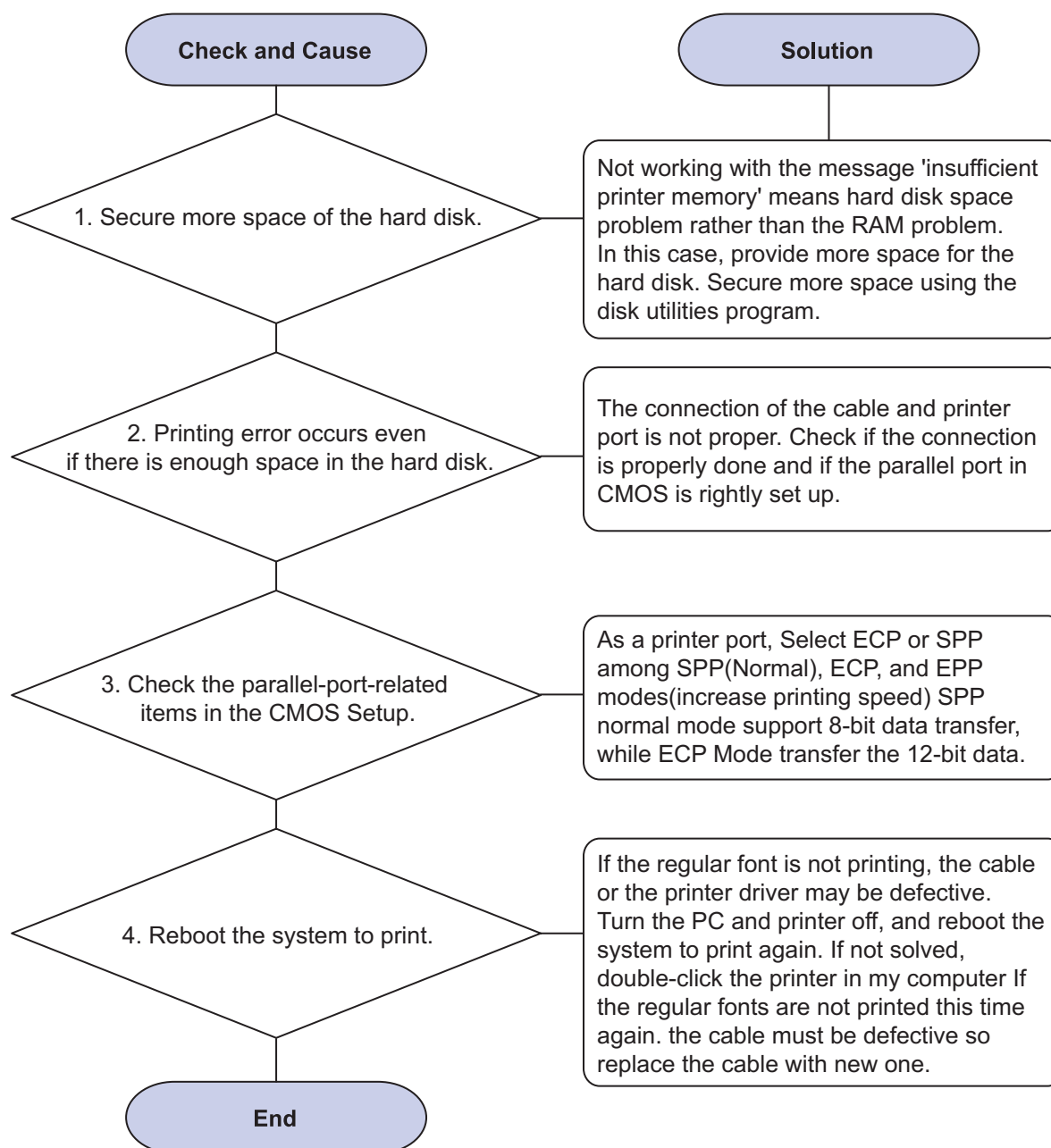

### 3) Abnormal Printing

**Description :** The printing is not working properly even when the cable has no problem. (even after the cable is replaced) If the printer won't work at all or the strange fonts are repeated, the printer driver may be defective or wrong setup in the CMOS Setup.

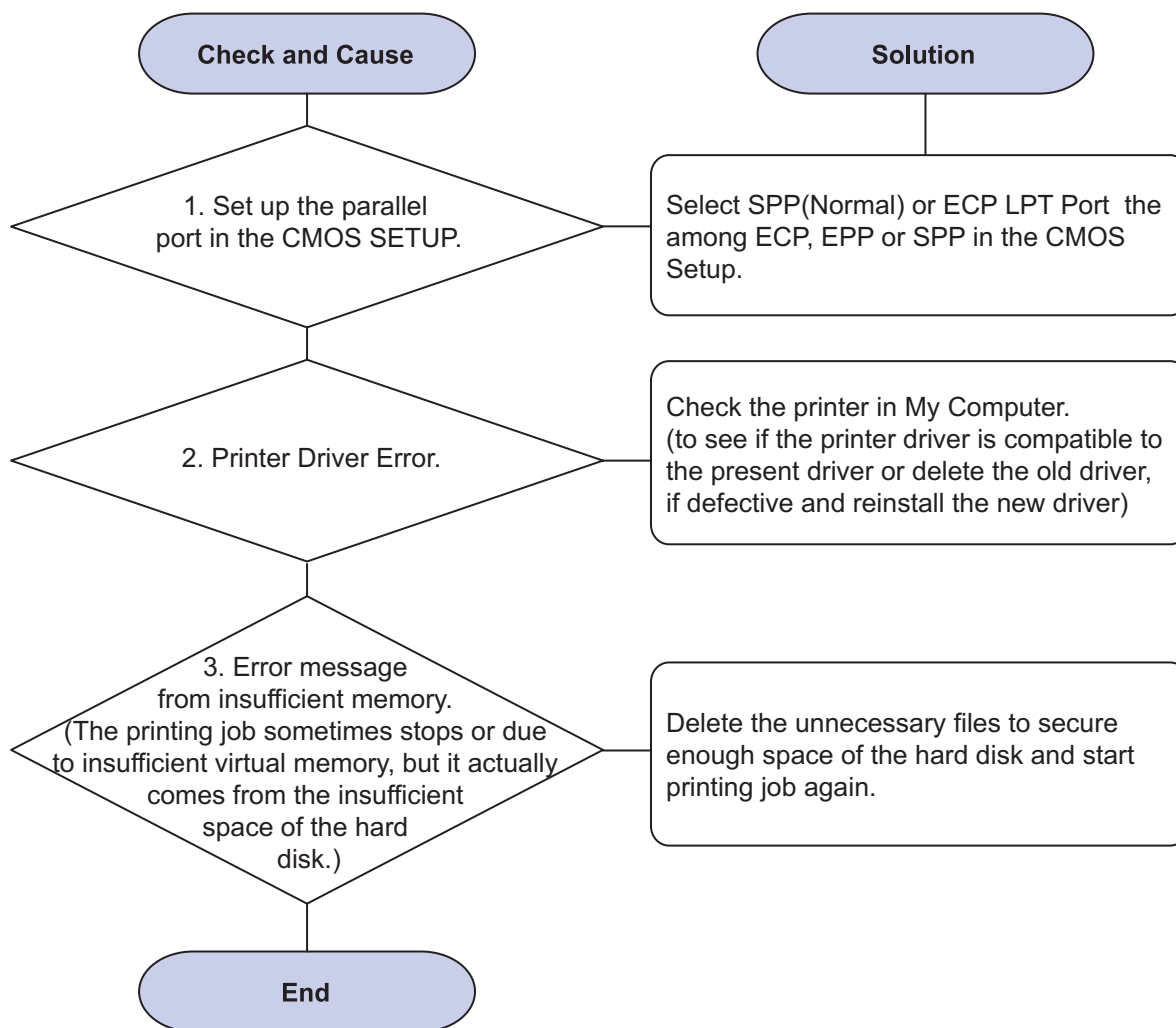

#### 4) SPOOL Error

**Description :** To spool which stands for “simultaneous peripheral operations online” a computer document or task list (or “job”) is to read it in and store it, usually on a hard disk or larger storage medium so that it can be printed or otherwise processed at a more convenient time (for example, when a printer is finished printing its current document).

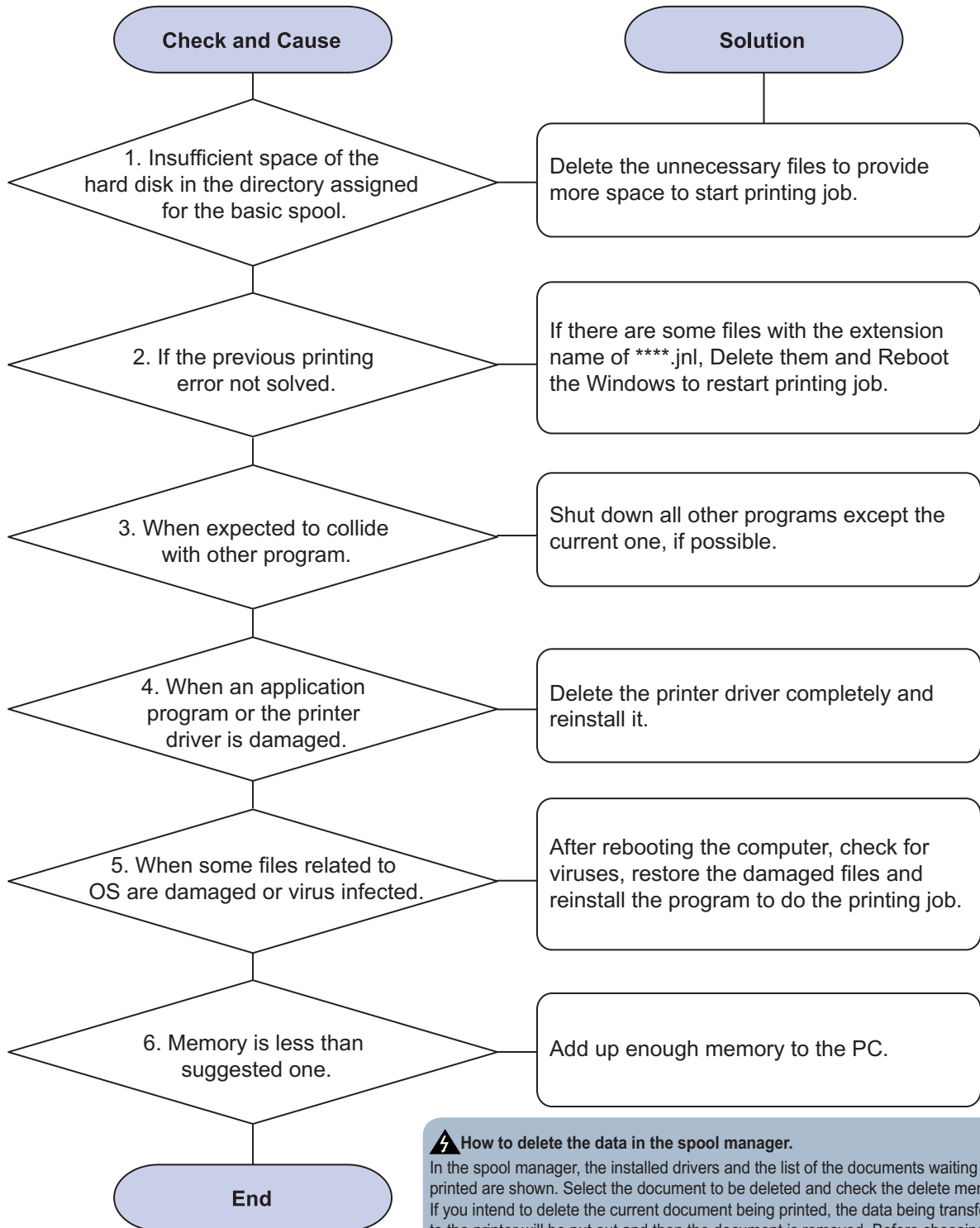

**⚠ How to delete the data in the spool manager.**

In the spool manager, the installed drivers and the list of the documents waiting to be printed are shown. Select the document to be deleted and check the delete menu. If you intend to delete the current document being printed, the data being transferred to the printer will be put out and then the document is removed. Before choosing the document, the menu is still inactive. Or put the document out of the list and repeat the routine as in the above or finish the spool manager.

## 4.2.6 Fax & Phone Problems

### 1) No Dial Tone

Description : While on-hook button is pressed, there is no dial tone.

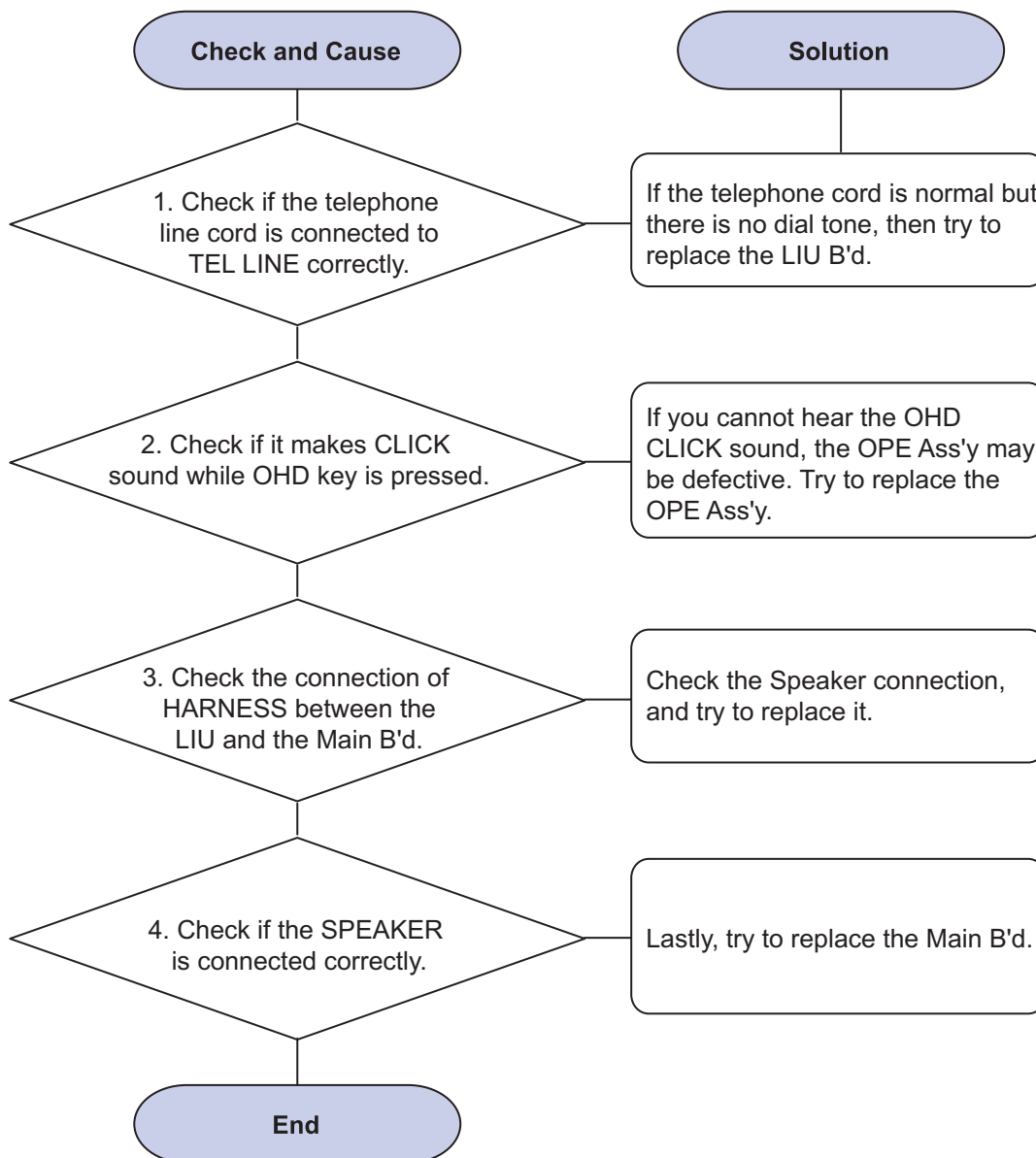

## 2) Defective MF DIAL

Description : The MF DIAL is not functioning.

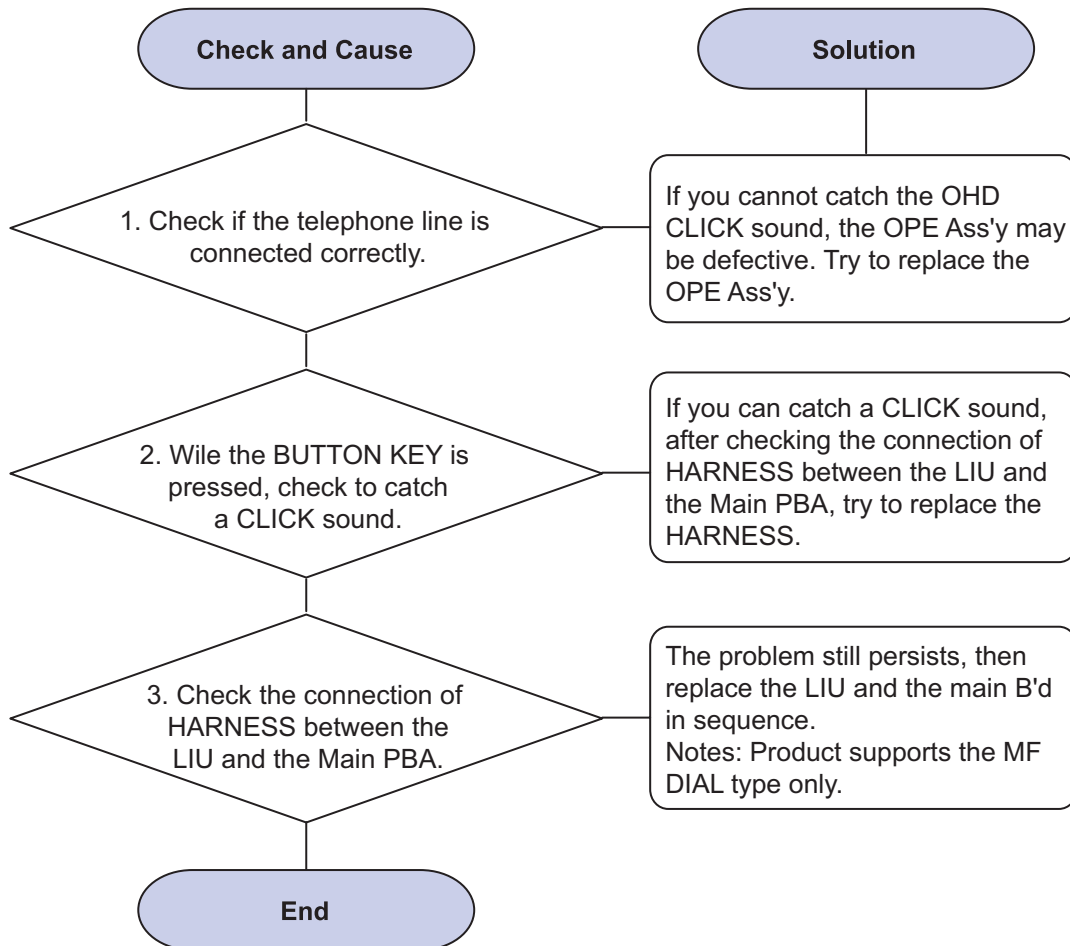

### 3) Defective FAX FORWARD/RECEIVE

Description : The FAX FORWARD/RECEIVE is not functioning.

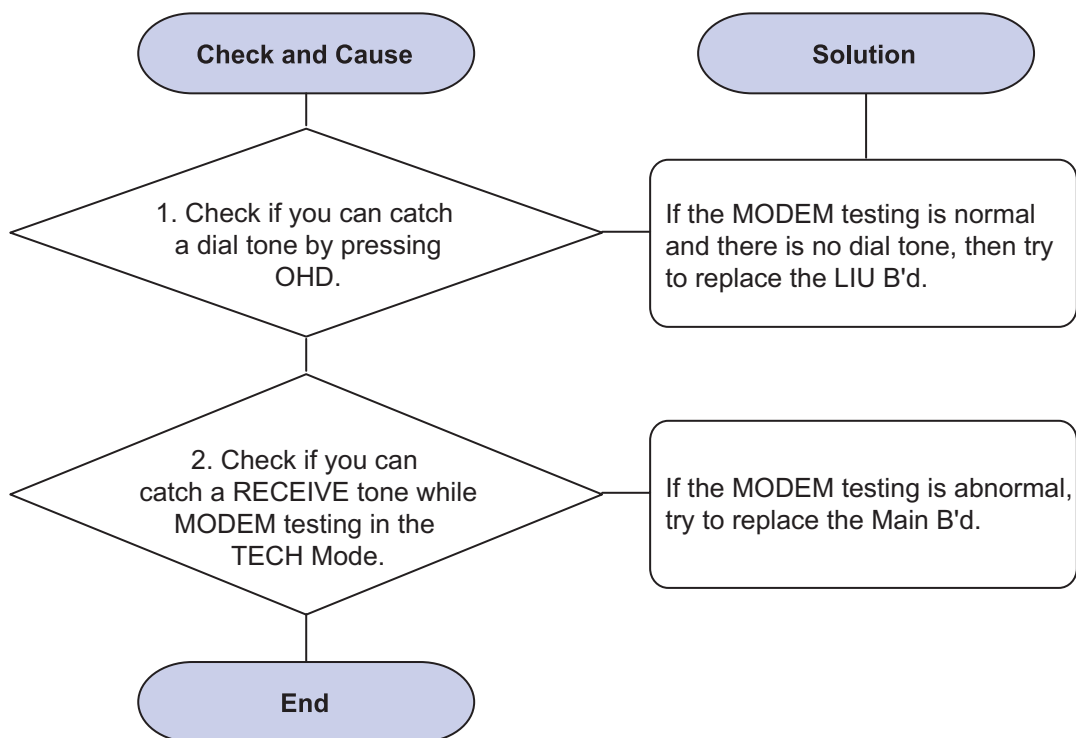



#### 4) Defective FAX FORWARD

Description : RECEIVE is functioning, but FORWARD is not functioning or the received data are broken.

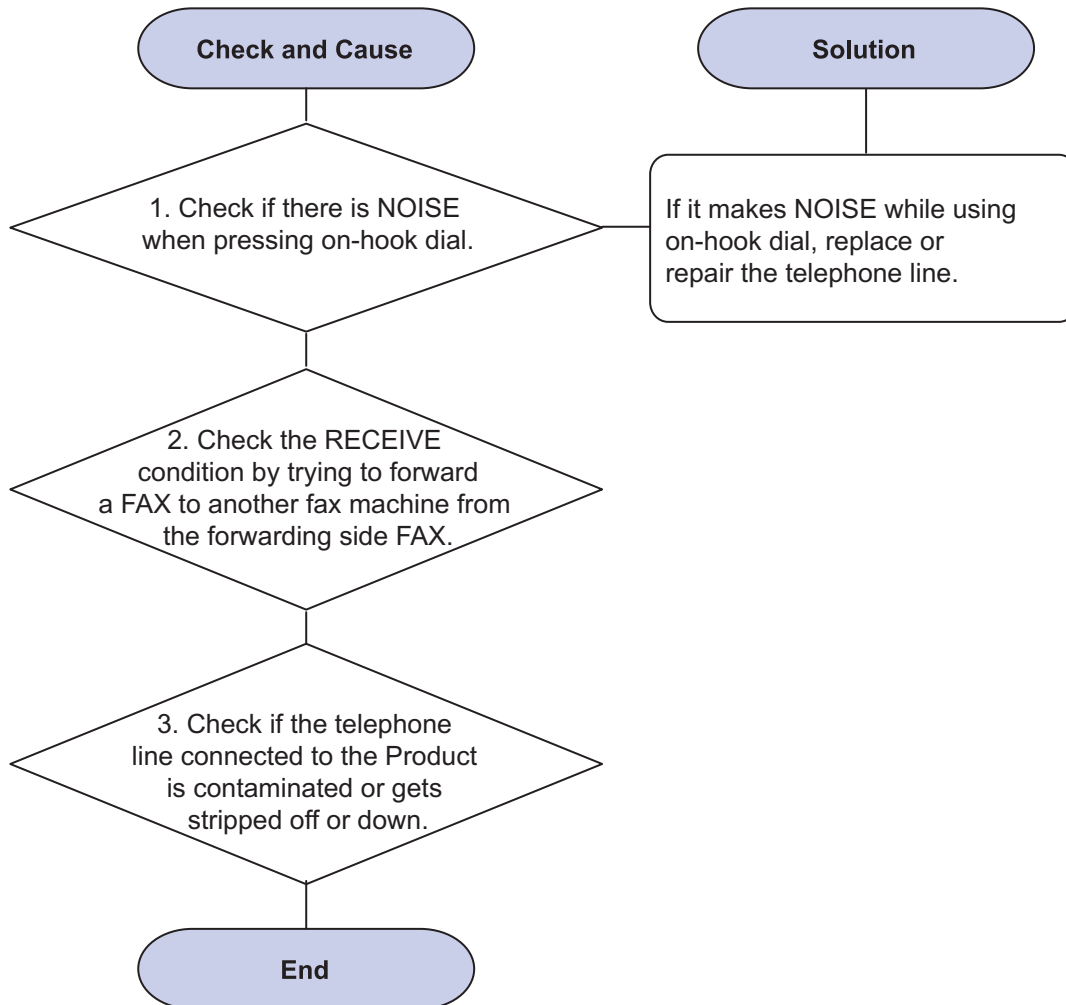

5) Defective FAX RECEIVE (1)

Description : FORWARD is functioning, but RECEIVE is not functioning or the received data are broken.

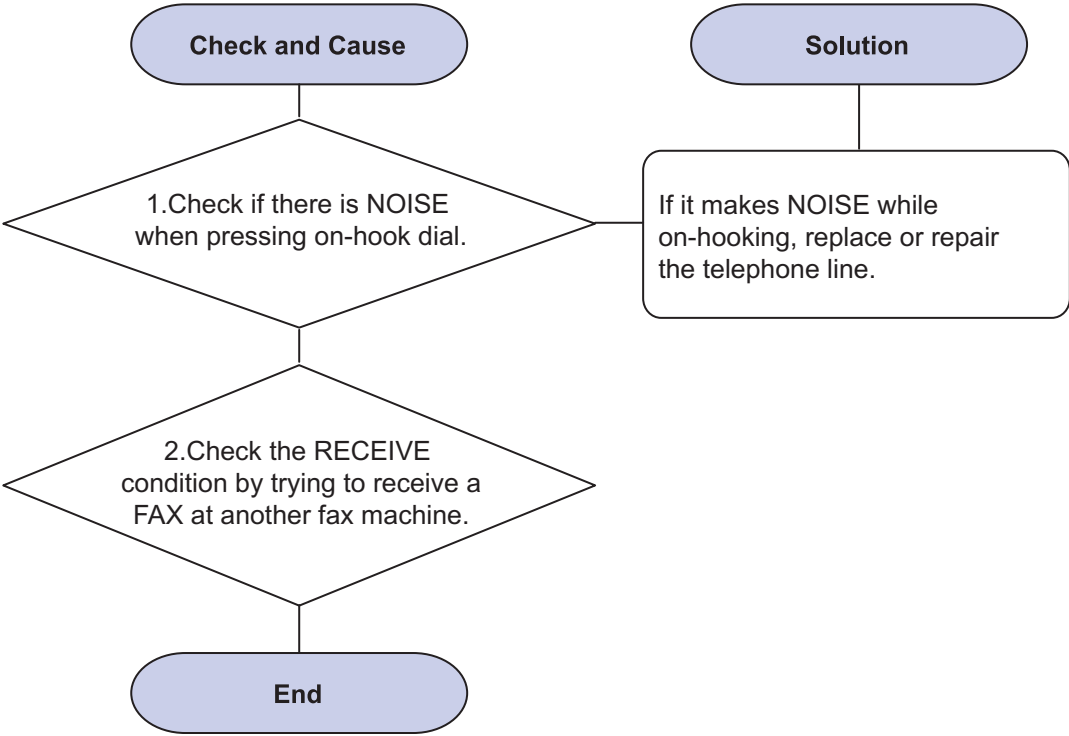

## 6) Defective FAX RECEIVE (2)

Description : The received data are lengthened or cut in the printing.

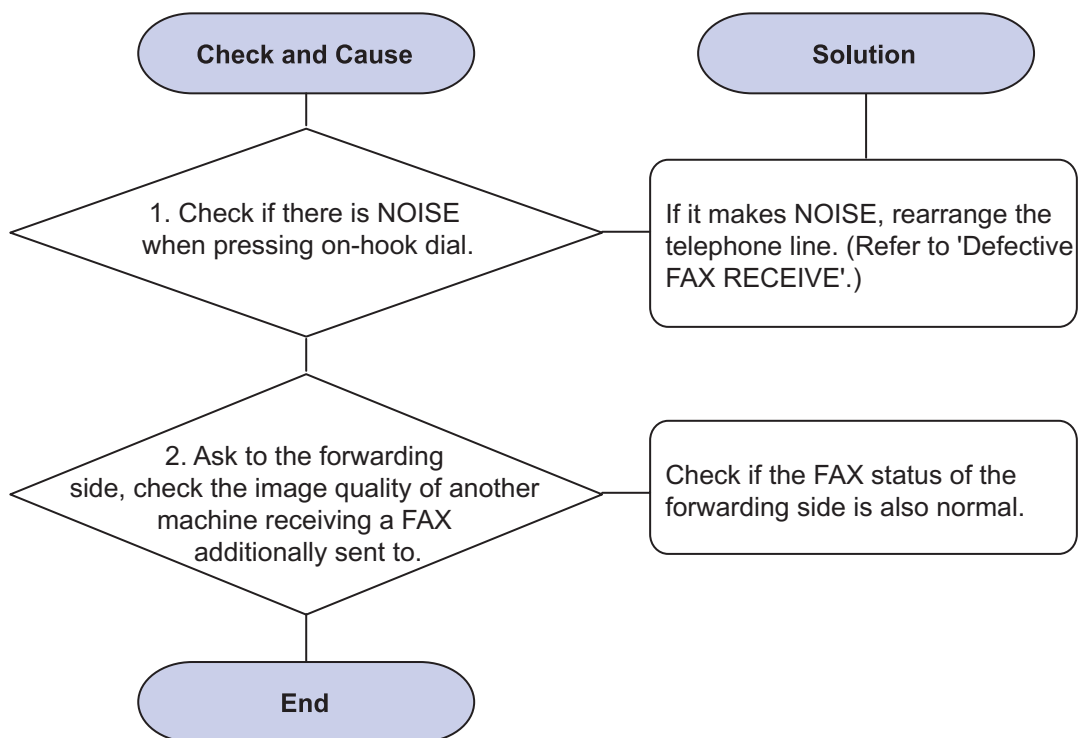

### 7) Defective FAX RECEIVE (3)

Description : The phone is ringing continuously, but it cannot receive.

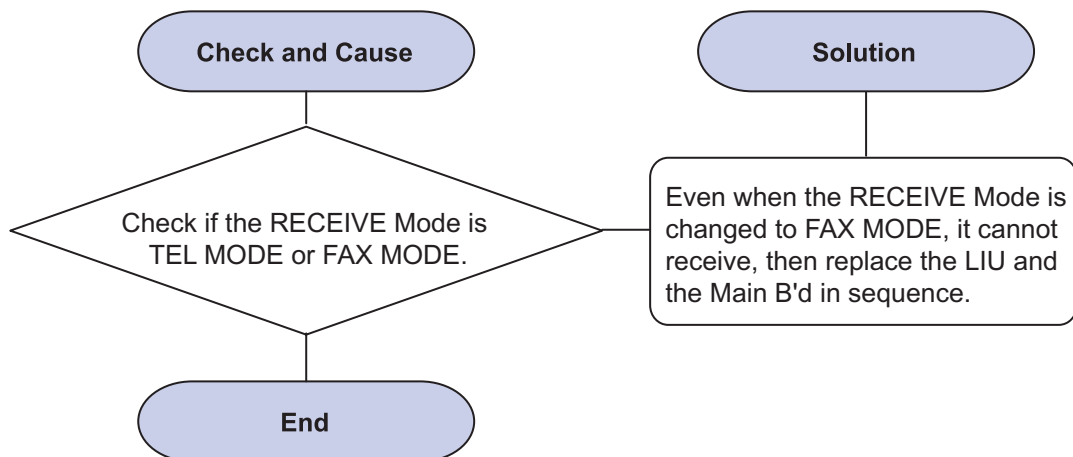

### 8) Defective FAX RECEIVE (4)

Description : The received data is reduced by more than 50% in the printing.

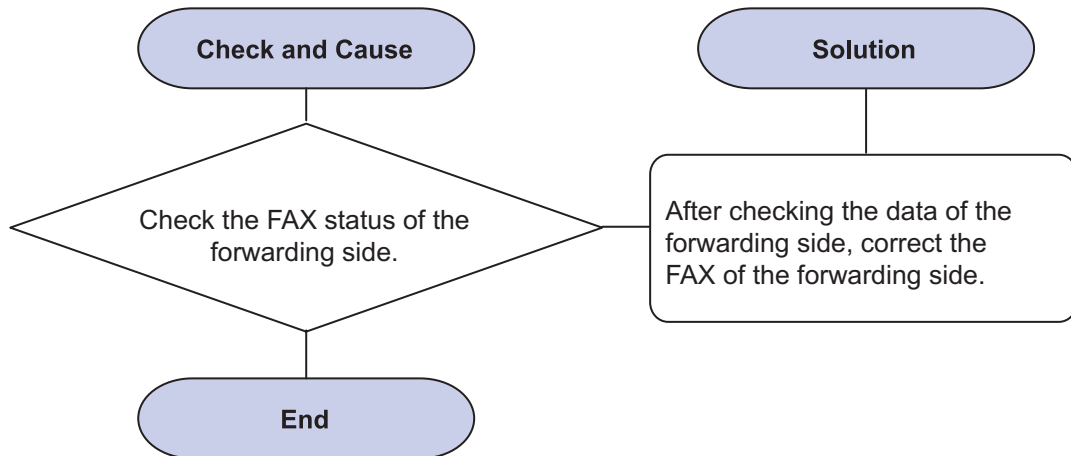

## 9) Defective Automatic Receiving

Description : The automatic receiving function is not working.

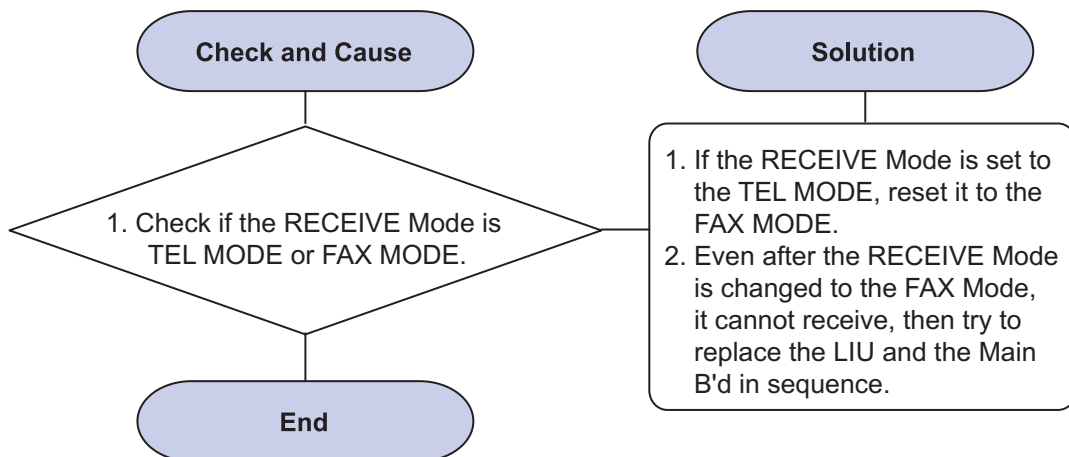

## 4.2.7 Copy Problems

### 1) Black Copy

Description : Black page is printed out when copy.

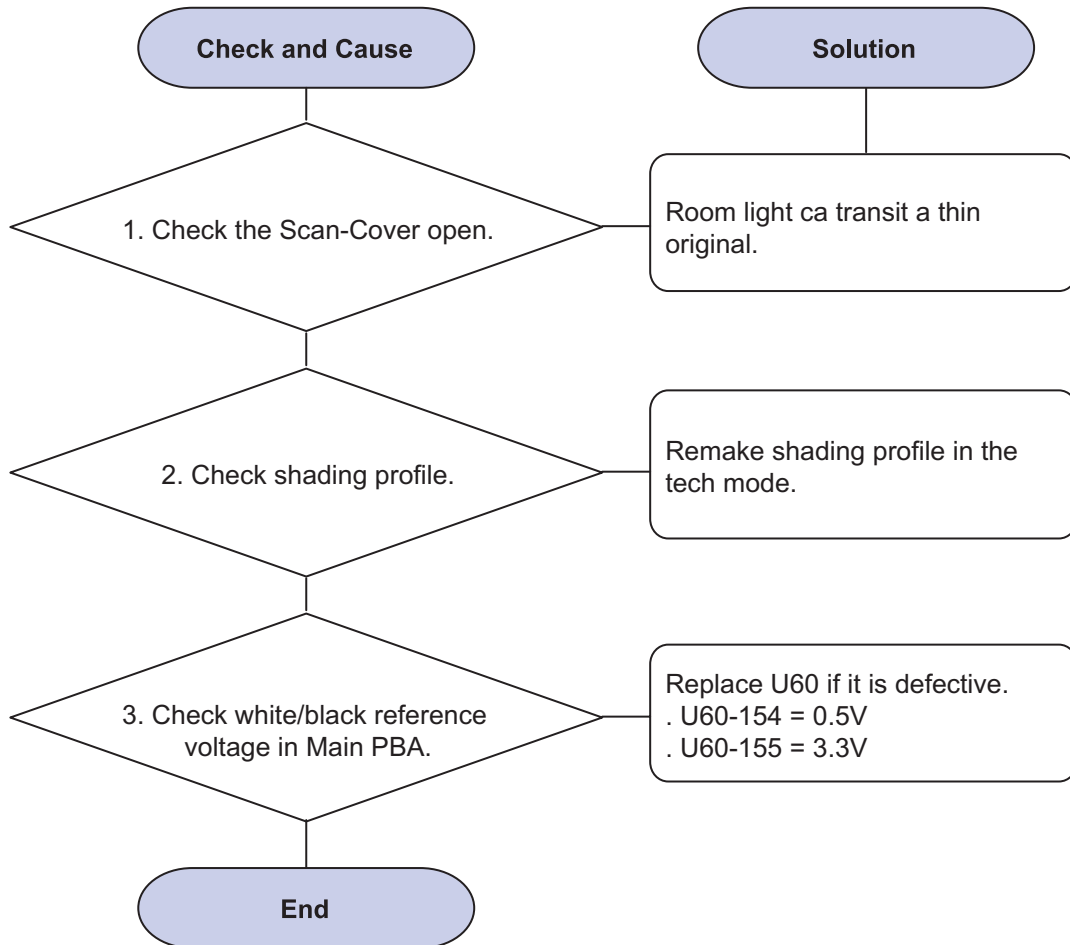

## 2) White Copy

Description : White page is printed out when Copy.

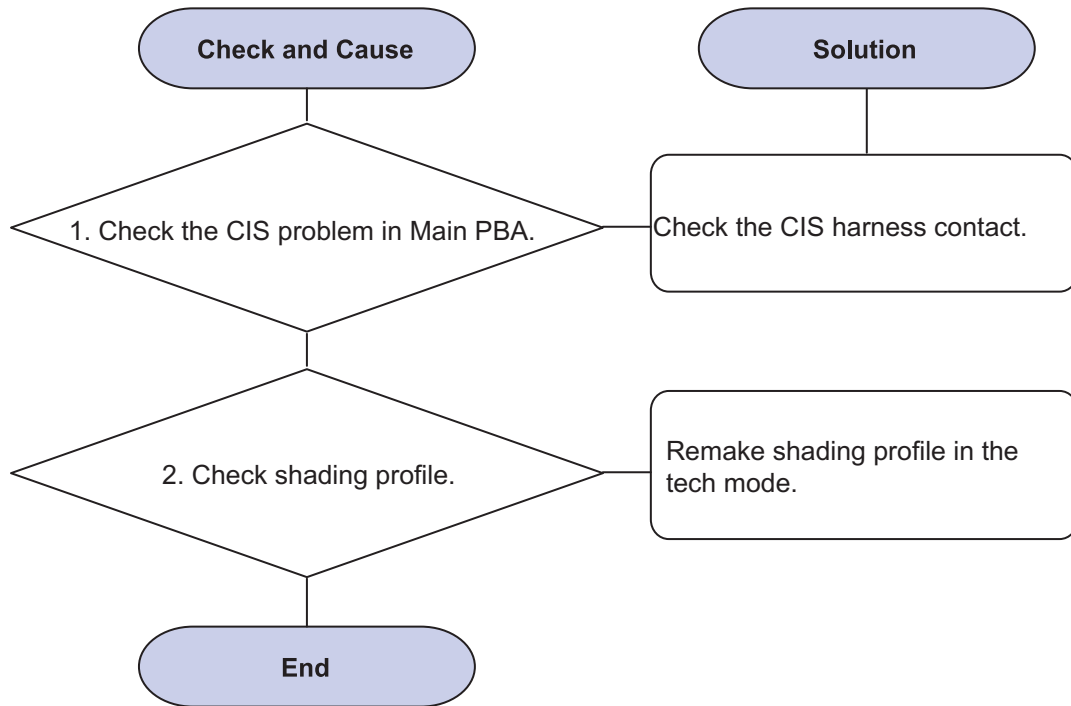



### 3) Abnormal noise

Description : There is noise when copy.

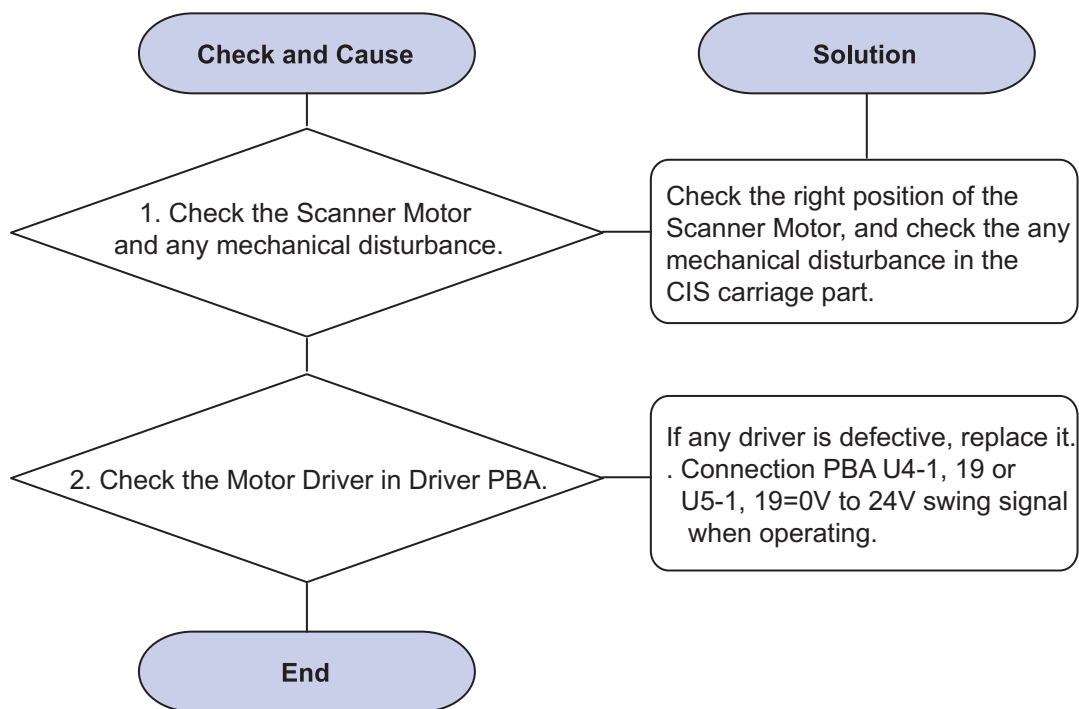

#### 4) Defective Image Quality

Description : The copied image is light or bad.

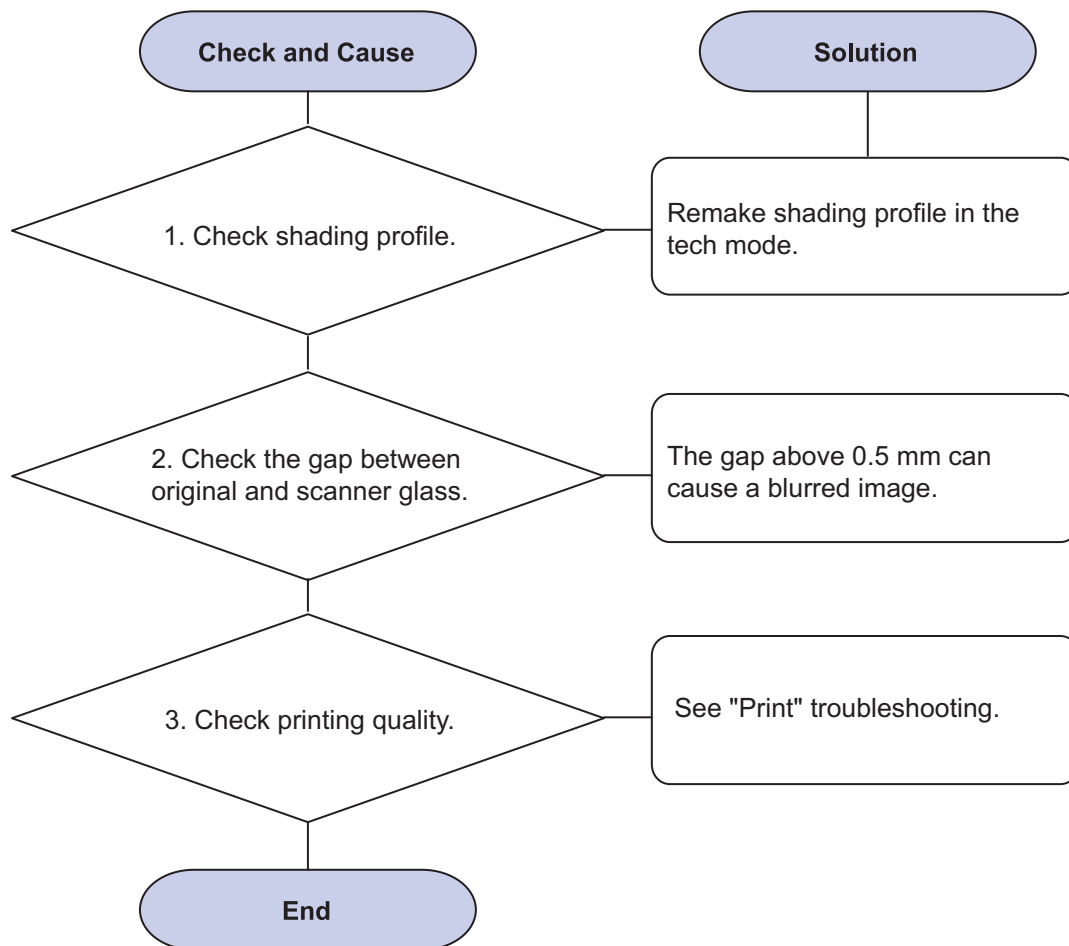

## 4.2.8 Scanning Problems

### 1) Defective PC Scan

Description : The PC Scan is not functioning at all.

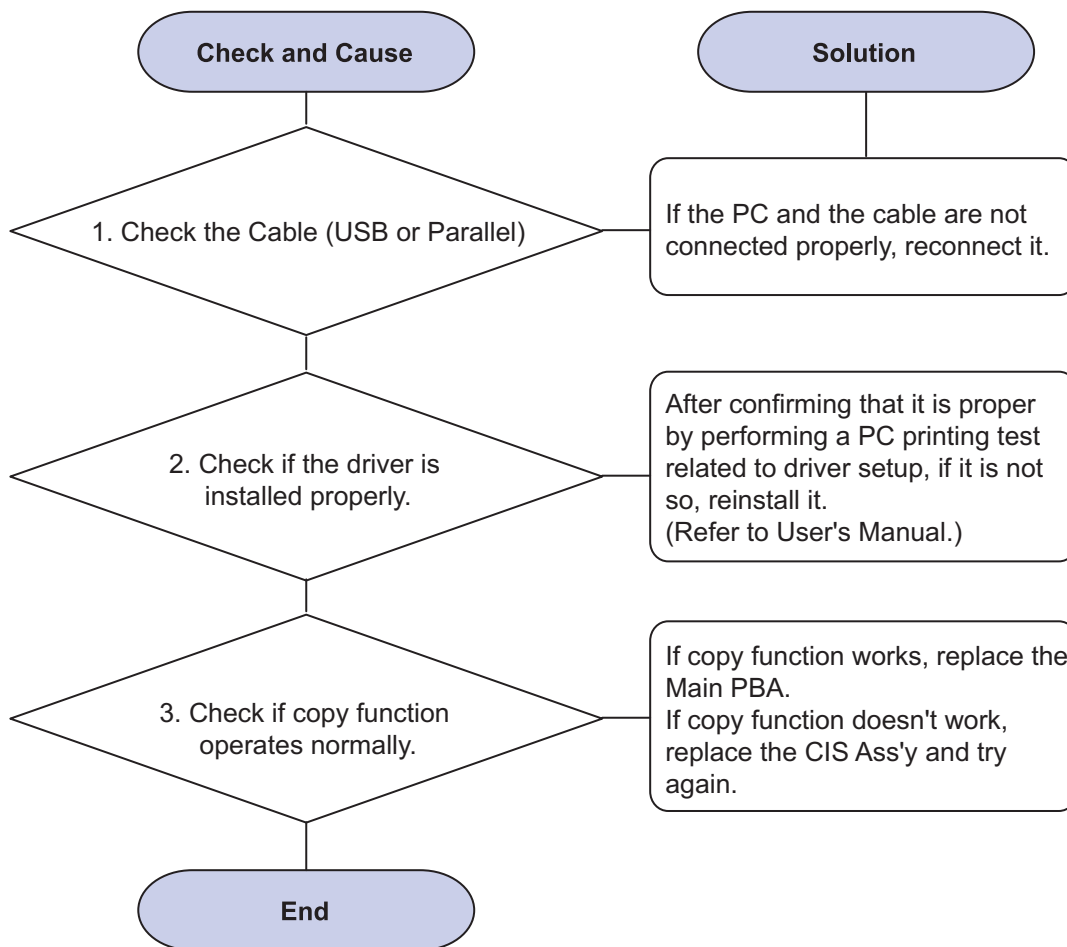

## 2) Defective Image Quality of PC Scan

Description : The image PC scanned is not clear or bad.

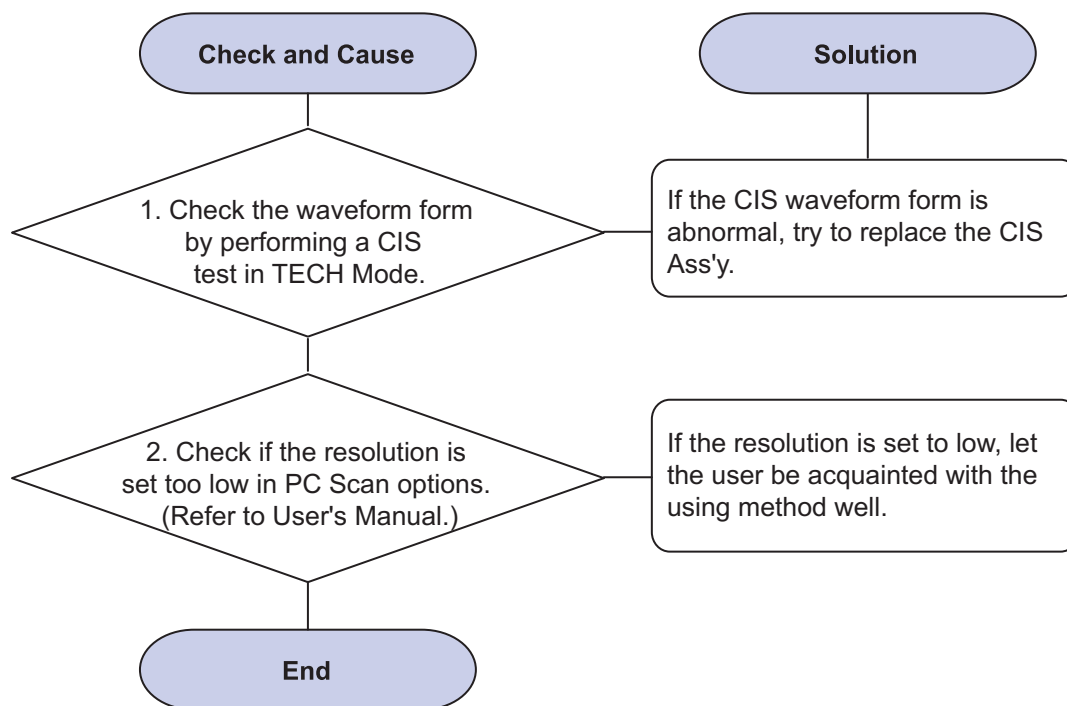

## 5. ExplodedView and Parts

# Contents

Thumbnail .....	5-2	5.7 ADF Ass'y .....	5-19
5.1 Main .....	5-3	5.8 Platen Ass'y .....	5-21
5.2 Cover Ass'y .....	5-5	5.9 OPE Unit .....	5-23
5.3 Cover Middle .....	5-7	5.10 Duplex Unit .....	5-25
5.4 Frame .....	5-9	5.11 Fuser.....	5-27
5.5 Main Drive .....	5-15	5.12 Cassette .....	5-30
5.6 Scan Ass'y .....	5-17	5.13 SCF .....	5-32

### DIGITAL LASER MFP



### The keynote of Product

- Print/Copy Speed  
SCX-4824FN : 24 ppm (A4) / 24 cpm (A4)  
SCX-4828FN : 28 ppm (A4) / 28 cpm (A4)
- Print resolution  
: 1200 dpi effective output
- CPU : 360 Mhz
- PCL5e, PCL6, IBM ProPrinter, EPSON PS(4828FN)
- Memory  
SCX-4824FN : 64MB(Max. 320MB)  
SCX-4828FN : 128MB(Max. 384MB)
- ADF : 30(4824FN) / 50(4828FN) Sheet
- MP : 1 Sheet
- Toner : 2K(Initial)/ 5K(Sales)

## Thumbnail

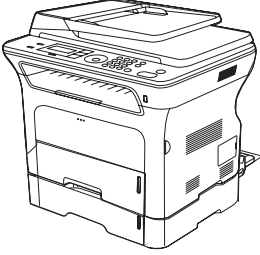
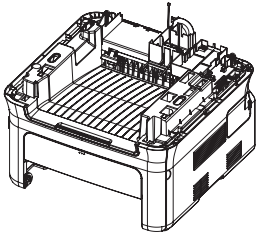
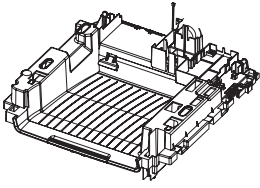
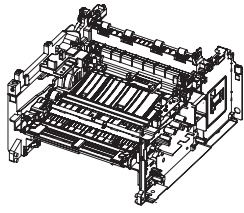
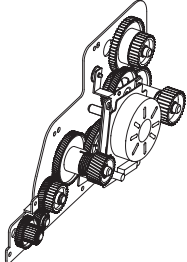
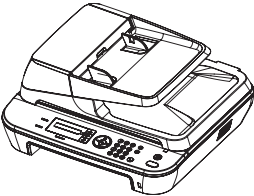
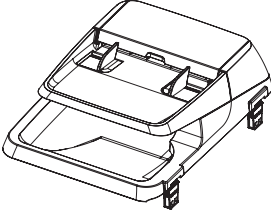
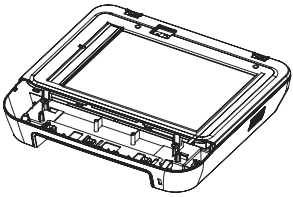
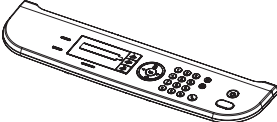
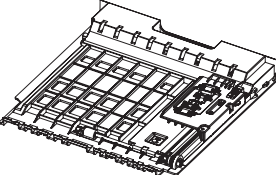
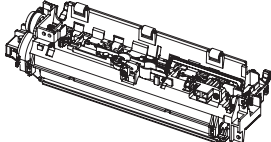
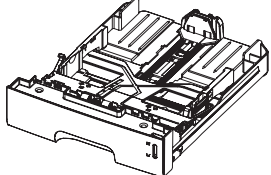
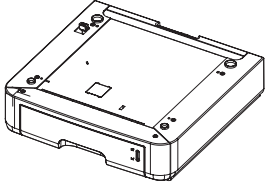
			
5.1 Main	5.2 Cover Ass'y	5.3 Cover Middle	5.4 Frame
			
5.5 Main Drive	5.6 Scan Ass'y	5.7 ADF Ass'y	5.8 Platen Ass'y
			
5.9 OPE Unit	5.10 Duplex Unit	5.11 Fuser	5.12 Cassette
			
5.13 SCF			

## 5.1 Main

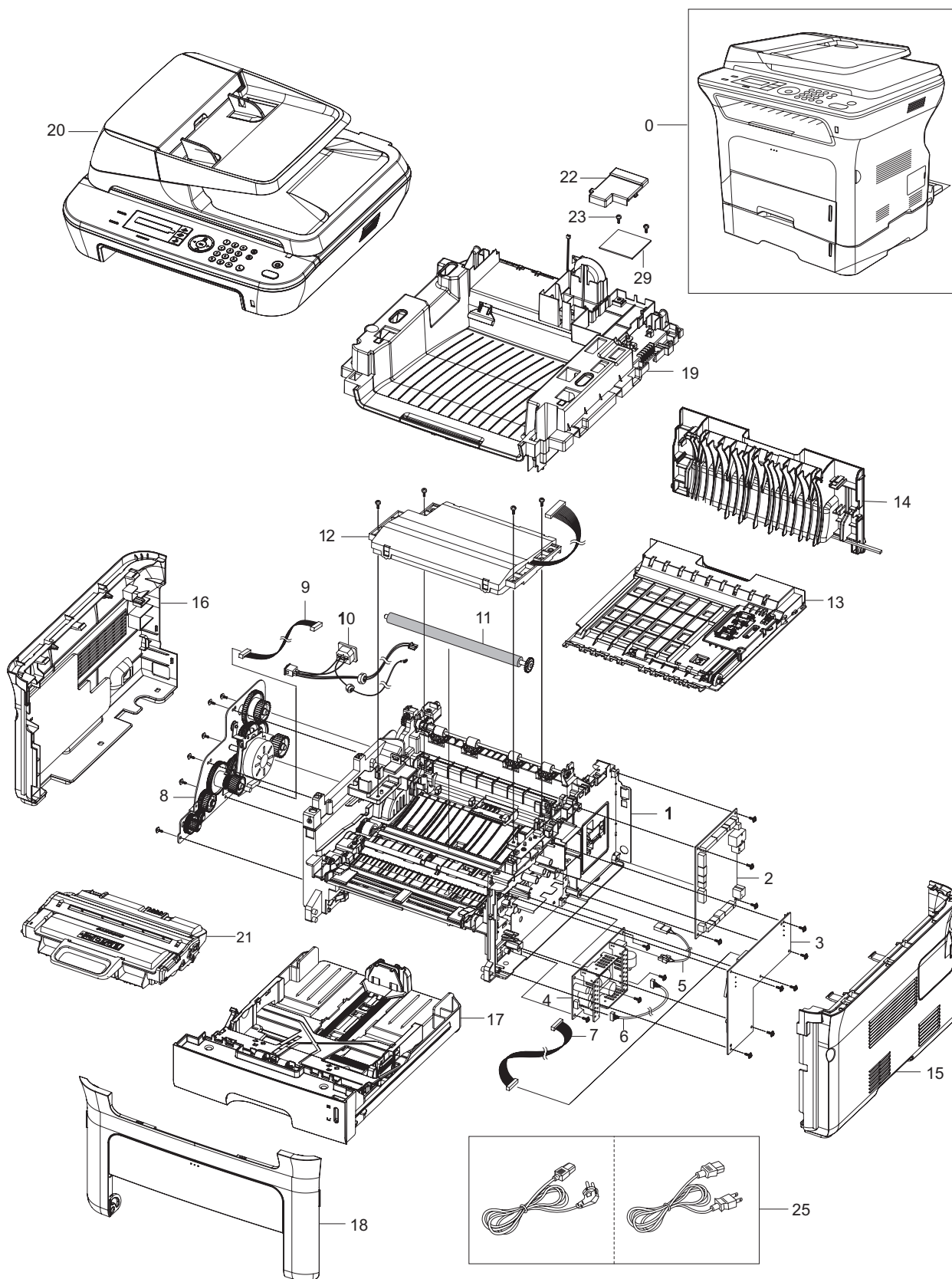

## Main Parts List

SA : SERVICE AVAILABLE, SNA : SERVICE not AVAILABLE

Drawer#	SEC_Code	Description	QT'y	Service	Remark
5.1-0	SCX-4828FN	28 PPM, Mono Laser MFP			
	SCX-4824FN	24 PPM, Mono Laser MFP			
5.1-1	JC96-05077A	ELA HOU-FRAME_220V	1	SA	
	JC96-05076A	ELA HOU-FRAME_110V	1	SA	
5.1-2	JC92-02028A	PBA-MAIN	1	SA	SCX-4828FN
	JC92-02038A	PBA-MAIN	1	SA	SCX-4824FN
5.1-3	JC44-00156A	HVPS	1	SA	
5.1-4	JC44-00095B	SMPS-V1	1	SA	110V
	JC44-00096B	SMPS-V2C	1	SA	220V
5.1-5	JC39-00817A	CBF HARNESS-FUSER AC(SMPS)	1	SA	
5.1-6	JC39-00828A	HARNESS-SMPS	1	SA	
5.1-7	JC39-00824A	CBF HARNESS-HVPS	1	SA	
5.1-8	JC96-04731A	ELA UNIT-RX DRIVE	1	SA	
5.1-9	JC39-00820A	CBF HARNESS-MOTOR & SOLENOID	1	SA	
5.1-10	JC39-00816A	CBF HARNESS-AC-INLET	1	SA	
5.1-11	JC66-01218A	ROLLER-TRANSFER	1	SA	
5.1-12	JC96-04733A	ELA UNIT-LSU	1	SA	
5.1-13	JC96-04736A	MEA UNIT-DUPLEX	1	SA	
5.1-14	JC97-03015A	MEA UNIT-COVER_REAR	1	SA	
5.1-15	JC96-05079B	ELA HOU-COVER-RIGHT	1	SA	
5.1-16	JC97-03221A	MEA-COVER LEFT	1	SA	
5.1-17	JC97-03017A	MEA UNIT-CASSETTE	1	SA	
5.1-18	JC97-03222A	MEA-COVER FRONT	1	SA	
5.1-19	JC96-05078A	ELA HOU-COVER-MIDDLE	1	SA	
5.1-20	JC96-05074Q	ELA HOU-SCAN_LOW	1	SA	
5.1-21	JC96-04823B	CARTRIDGE-TONER	1	SNA	
5.1-22	JC63-01926A	COVER-H_FAX_BOARD	1	SA	
5.1-23	6003-000196	SCREW-TAPTITE	2	SA	
5.1-24	JC92-01746A	PBA SUB-MODEM	1	SA	
5.1-25	3903-000146	CBF-POWER CORD	1	SA	



## 5.2 Cover Ass'y

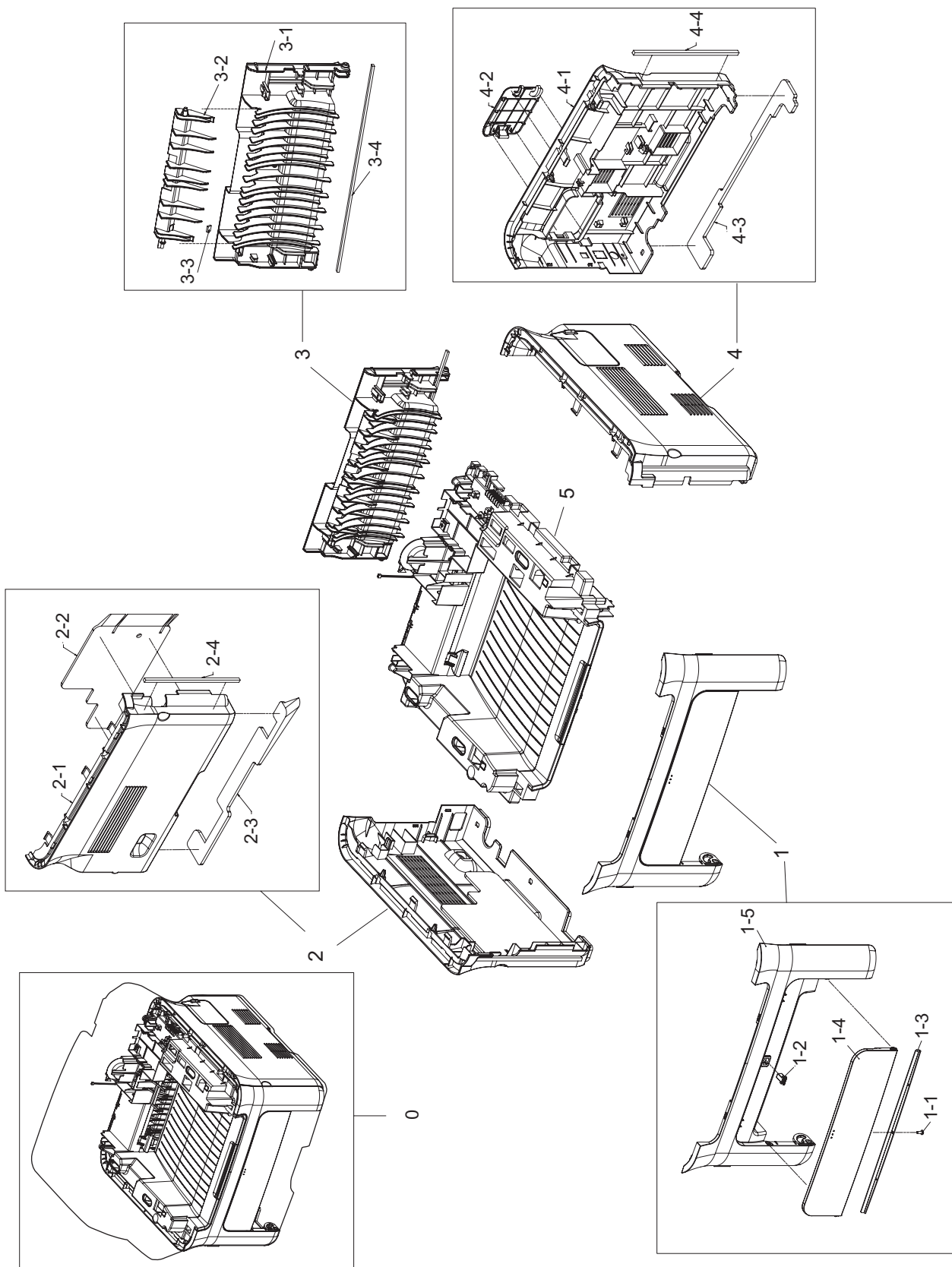

## Cover Ass'y Parts List

SA : SERVICE AVAILABLE, SNA : SERVICE not AVAILABLE

Drawer#	SEC_Code	Description	QT'y	Service	Remark
5.2-0	JC96-05099B	ELA HOU-COVER	1	SNA	
5.2-1	JC97-03222A	MEA-COVER FRONT	1	SA	
5.2-1-1	6003-000282	SCREW-TAPTITE	1	SNA	
5.2-1-2	JB64-00007A	LOCKER-LATCH PUSH	1	SA	
5.2-1-3	JC61-02267A	BRACKET-MANUAL	1	SNA	
5.2-1-4	JC63-01569D	COVER-MANUAL	1	SA	
5.2-1-5	JC63-01919A	COVER-FRONT	1	SNA	
5.2-2	JC97-03221A	MEA-COVER LEFT	1	SA	
5.2-2-1	JC63-01920A	COVER-LEFT	1	SNA	
5.2-2-2	JC72-01405A	SPONGE-COVER SIDE L	1	SNA	
5.2-2-3	JC72-01460A	SPONGE-SIDE BOTTOM L	1	SNA	
5.2-2-4	JC72-01462A	SPONGE-SIDE FRONT	1	SNA	
5.2-3	JC97-03015A	MEA UNIT-COVER_REAR	1	SA	
5.2-3-1	JC63-01526A	COVER-REAR	1	SA	
5.2-3-2	JC61-02399A	GUIDE-CHANGE_DUP	1	SNA	
5.2-3-3	JC72-01444A	SPONGE-GUIDE CHANGE DUP	1	SNA	
5.2-3-4	JC72-01445A	SPONGE-COVER REAR	1	SNA	
5.2-4	JC96-05079A	ELA HOU-COVER-RIGHT	1	SA	
5.2-4-1	JC63-01925B	COVER-RIGHT	1	SNA	
5.2-4-2	JC63-01928B	COVER-RIGHT DIMM	1	SNA	
5.2-4-3	JC72-01461A	SPONGE-SIDE BOTTOM R	1	SNA	
5.2-4-4	JC72-01462A	SPONGE-SIDE FRONT	1	SNA	

### 5.3 Cover Middle

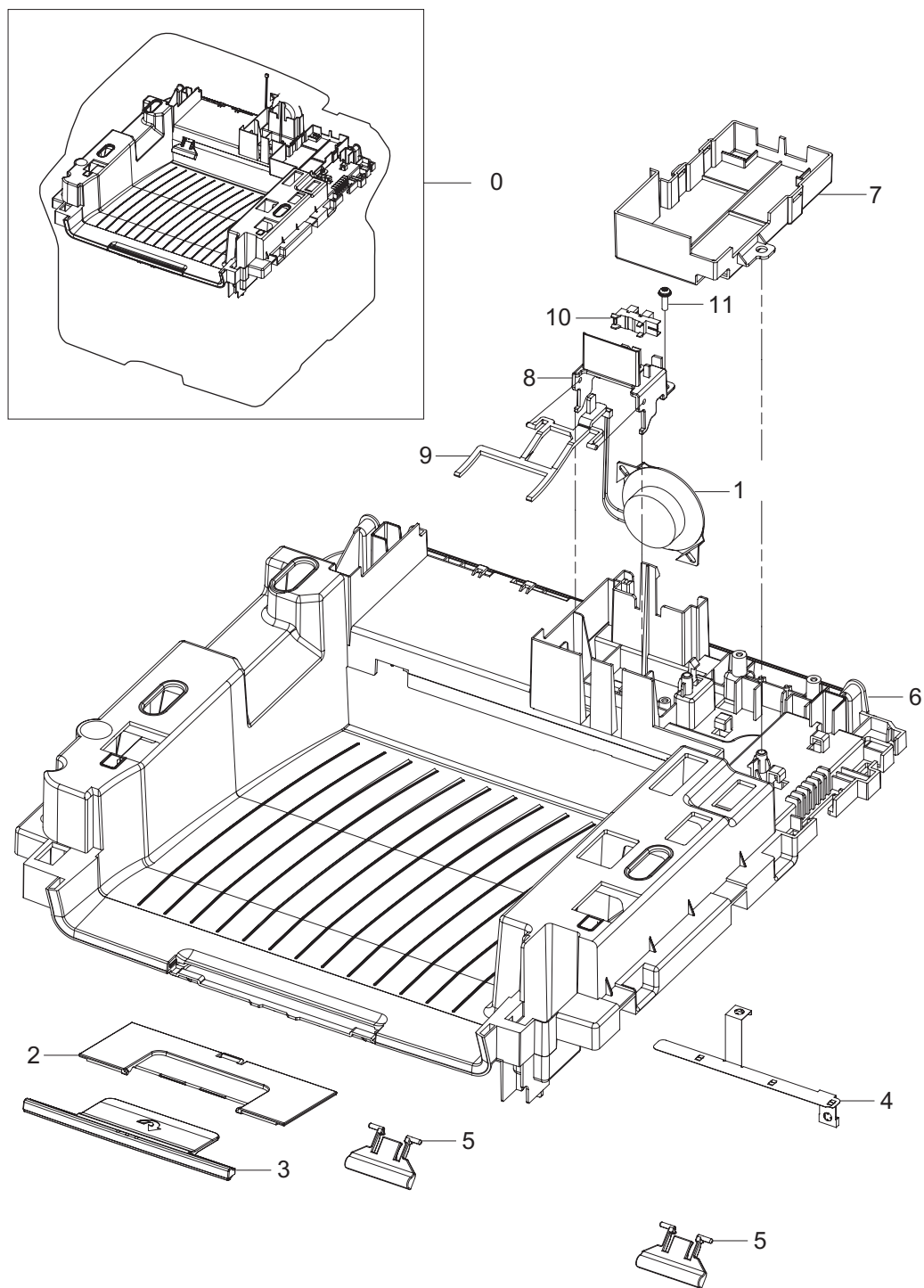

## Cover Middle Parts List

SA : SERVICE AVAILABLE, SNA : SERVICE not AVAILABLE

Drawer#	SEC_Code	Description	QT'y	Service	Remark
5.3-0	JC96-05078A	ELA HOU-COVER-MIDDLE	1	SA	
5.3-1	3001-002262	SPEAKER	1	SA	
5.3-2	JC61-02583A	STACKER-RX LARGE	1	SNA	
5.3-3	JC61-02584A	STACKER-RX SMALL	1	SNA	
5.3-4	JC63-01913A	GROUND-BRUSH	1	SNA	
5.3-5	JC72-01343A	PMO-SUB_M_STACKER	2	SA	
5.3-6	JC63-01921A	COVER-MIDDLE	1	SNA	
5.3-7	JC63-01927A	COVER-L_FAX_BOARD	1	SNA	
5.3-8	JC61-02701A	HOLDER-ACTUATOR BINFUL	1	SNA	
5.3-9	JC66-02009A	ACTUATOR-BIN FULL	1	SNA	
5.3-10	0604-001095	PHOTO-INTERRUPTER	1	SNA	
5.3-11	6003-000196	SCREW-TAPTITE	1	SA	
-	JC39-00971A	HARNESS-BIN FULL UPPER	1	SNA	
-	JC39-00949A	HARNESS-SPEACKER JOINT	1	SNA	

# 5.4 Frame1

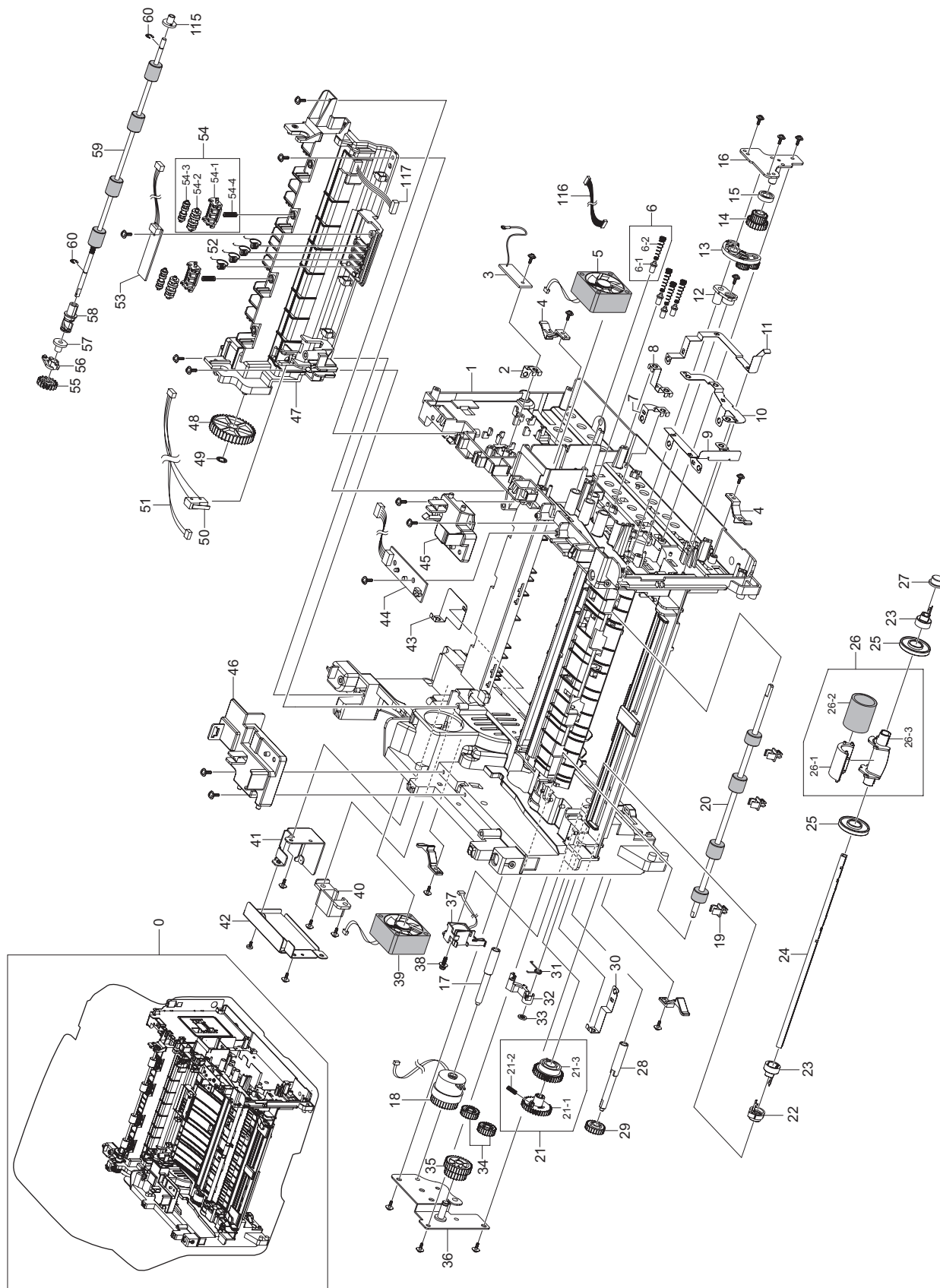

### 5.4 Frame2

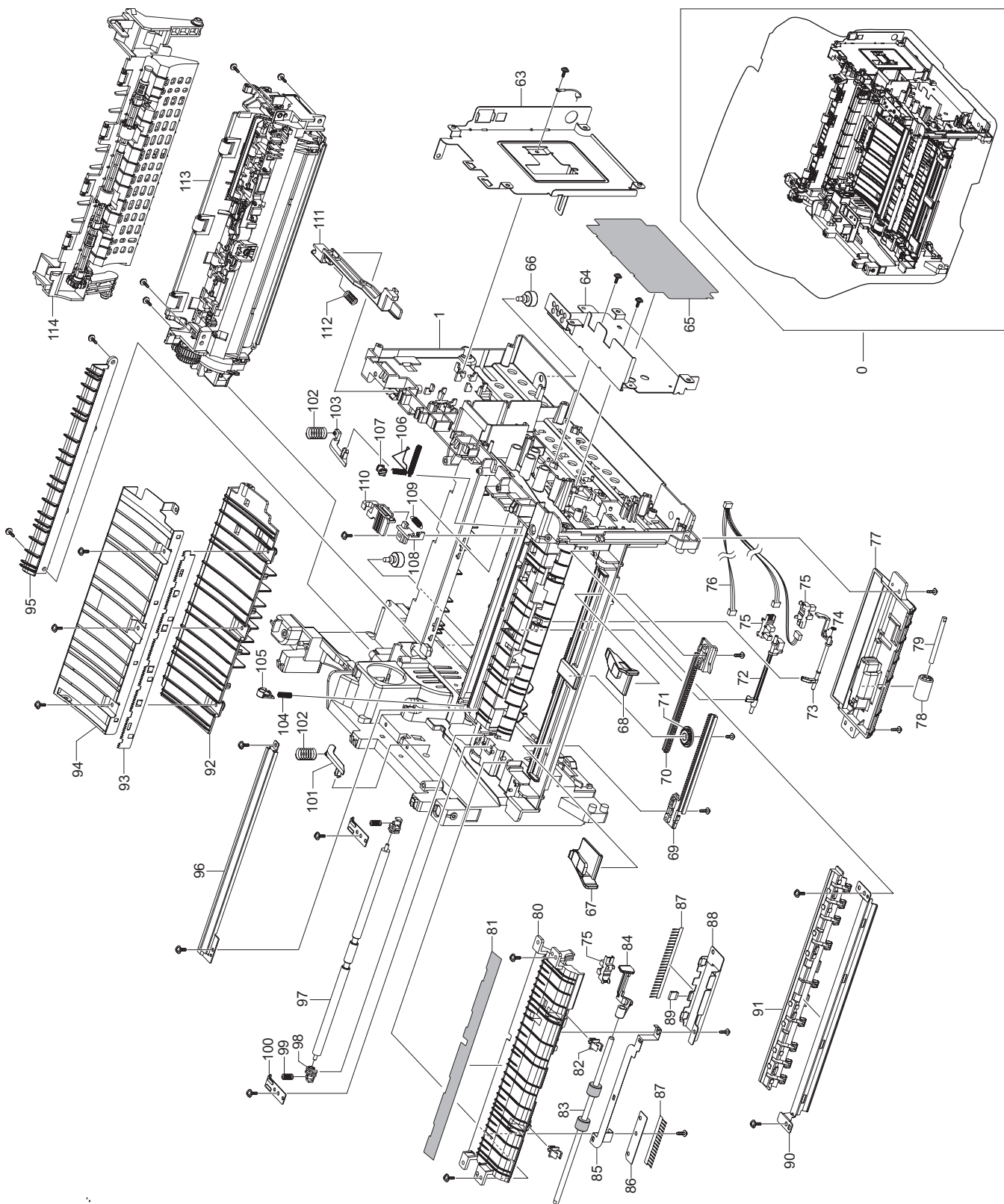

## Frame Parts List

SA : SERVICE AVAILABLE, SNA : SERVICE not AVAILABLE

Drawer#	SEC_Code	Description	QT'y	Service	Remark
5.4-0	JC96-05076A	ELA HOU-FRAME_110V		SA	110V
5.4-0	JC96-05077A	ELA HOU-FRAME_220V		SA	220V
5.4-1	JC61-02187A	FRAME-BASE	1	SA	
5.4-2	JC63-01616A	GROUND-ZENOR	1	SA	
5.4-3	JC92-01488A	PBA MAIN-ZENER	1	SA	
5.4-4	JC72-00983A	PMO-LOCKER CST	4	SA	
5.4-5	JC31-00085A	FAN-DC	1	SA	
5.4-6-1	JC70-40912A	ICT SHAFT HV LARGE	4	SA	
5.4-6-2	JC61-00031A	SPRING ETC-HV LARGE	4	SA	
5.4-7	JC63-01619A	GROUND-MOTOR_MAIN	1	SA	
5.4-8	JC63-01618A	GROUND-CONTROLLER	1	SA	
5.4-9	JC63-01620A	GROUND-PAPER	1	SA	
5.4-10	JC63-01613A	GROUND-BRKT FRONT	1	SA	
5.4-11	JC63-01621A	GROUND-TRANSFER	1	SA	
5.4-12	JC61-02233A	HOLDER-REGI	1	SA	
5.4-13	JC96-04732A	MEA UNIT SWING	1	SA	
5.4-14	JC66-01651A	GEAR DUPLEX RDCN	1	SA	
5.4-15	JC61-02220A	COLLAR SWING	1	SA	
5.4-16	JC61-02225A	BRKT SWING	1	SA	
5.4-17	JC66-01655A	SHAFT-FEED REGI	1	SA	
5.4-18	JC66-01865A	CLUTCH ELECTRIC	1	SA	
5.4-19	JC72-00382B	PMO-BUSHING FEED	5	SA	
5.4-20	JC66-01656A	ROLLER-FEED REGI	1	SA	
5.4-21	JC97-03141A	MEA UNIT-GEAR PICK UP	1	SA	
5.4-21-1	JC72-00979A	GEAR PICK UP A	1	SA	
5.4-21-2	6107-001167	SPRING-CS	1	SA	
5.4-21-3	JC72-00980A	GEAR PICKUP B	1	SA	
5.4-22	JC66-01889A	CAM-PICK UP	1	SA	
5.4-23	JC72-00982A	PMO-IDLE PICK_UP	2	SA	
5.4-24	JC66-01692A	SHAFT-P-PICK_UP	1	SA	
5.4-25	JC61-00915A	STOPPER-M-PICK UP_R2	2	SA	
5.4-26	JC97-03062A	MEA UNIT-PICK UP	1	SA	
5.4-26-1	JC73-00265A	RUBBER PICK_UP	1	SA	
5.4-26-2	JC61-00910A	HOUSING-M-PICK UP	1	SA	
5.4-26-3	JC61-00909A	HOUSING-M-PICK UP_R2	1	SA	
5.4-27	JC61-00587A	BUSH-M-PICK_UP R2	1	SA	
5.4-28	JC66-01660A	SHAFT-FEED	1	SA	
5.4-29	JC66-01634A	GEAR-FEED DR 16	1	SA	
5.4-30	JC63-01614A	GROUND-GUIDE TR	1	SA	

## Frame Parts List

SA : SERVICE AVAILABLE, SNA : SERVICE not AVAILABLE

Drawer#	SEC_Code	Description	QT'y	Service	Remark
5.4-31	6107-001352	SPRING-TS	1	SA	
5.4-32	JC66-00377A	CAM-M-PICK_UP	1	SA	
5.4-33	6044-000001	RING-CS;ID3,OD3,T0.25,BLACK,SU	1	SA	
5.4-34	JC66-40964A	GEAR-EXIT,IDLE(Z17)	2	SA	
5.4-35	JC66-01627A	GEAR-FEED RDCN 24/19	1	SA	
5.4-36	JC61-02226A	BRACKET-FEED	1	SA	
5.4-37	JC33-00026A	SOLENOID PCIKUP	1	SA	
5.4-38	6003-000301	SCREW-TAPTITE	1	SA	
5.4-39	JC31-00085A	FAN-DC	1	SA	
5.4-40	JC61-02232A	HOLDER-POWER	1	SA	
5.4-41	JC63-01571A	SHIELD-POWER_SWITCH	1	SA	
5.4-42	JC61-02238A	PLATE-POWER CAP	1	SA	
5.4-43	JC63-01615A	GROUND-SCF	1	SA	
5.4-44	JC92-01439A	PBA LED-PANEL	1	SA	
5.4-45	JC61-02312A	FRAME-LSU-HOLDER-R	1	SA	
5.4-46	JC61-02311A	FRAME-LSU-HOLDER_L	1	SA	
5.4-47	JC61-02574A	FRAME-EXIT_HIGH	1	SA	
5.4-48	JC66-00875A	GEAR-M-FUSER IDLE 1	1	SA	
5.4-49	6044-001005	RING-CS	1	SA	
5.4-50	JC39-00826A	CBF HARNESS-LSU SW&FAN	1	SA	
5.4-52	JC65-00019A	TERMINAL-CRUM	4	SA	
5.4-53	JC92-01829A	PBA SUB-TERMINAL	1	SA	
5.4-54-1	JC61-02702A	HOLDER-EXIT ROLLER	2	SNA	
5.4-54-2	JC66-00824A	ROLLER-EXIT MAIN	2	SNA	
5.4-54-3	JC66-00830A	ROLLER-EXIT FR	2	SNA	
5.4-54-4	6107-001163	SPRING CS	2	SNA	
5.4-55	JC66-40209A	GEAR-M-EXIT	1	SA	
5.4-56	JC72-41191B	PMO-BEARING SHAFT	2	SA	
5.4-57	JC61-02308A	SUPPORT-ROLLER	1	SA	
5.4-59	JC66-01662A	ROLLER-EXIT F/DOWN	1	SA	
5.4-63	JC63-01916A	SHIELD-CONTROLLER	1	SA	
5.4-64	JC63-01573A	SHIELD-SMPS	1	SA	
5.4-65	JC62-00461A	INSULATION-SMPS	1	SA	
5.4-66	JC61-40001A	FOOT-ML80	2	SA	
5.4-67	JC70-00546A	ADJUST-MANUAL L	1	SA	
5.4-68	JC70-00547A	ADJUST-MANUAL R	1	SA	
5.4-69	JC70-00304A	ADJUST RACK-M-MANUAL	2	SA	
5.4-71	JC66-00387A	GEAR-RACK_PINION	1	SA	
5.4-72	JC66-01647A	ACTUATOR-FEED	1	SA	



## Frame Parts List

SA : SERVICE AVAILABLE, SNA : SERVICE not AVAILABLE

Drawer#	SEC_Code	Description	QT'y	Service	Remark
5.4-73	JC66-01646A	ACTUATOR-DUPLEX	1	SA	
5.4-74	6107-001164	SPRING-TS	2	SA	
5.4-75	0604-001095	PHOTO INTERRUPTER	3	SA	
5.4-76	JC39-00824A	CBF HARNESS-HVPS	1	SA	
5.4-77	JC61-02309A	FRAME-DUPLEX_PATH	1	SA	
5.4-78	JC66-01022A	ROLLER-M-IDLE SCF	1	SA	
5.4-79	JC66-01846A	SHAFT-DUP_ROLLER	1	SA	
5.4-80	JC61-02303A	GUIDE-FRAME_DUPLEX	1	SA	
5.4-81	JC63-01743A	SHEET-GUIDE_DUP_PATH	1	SA	
5.4-82	JC72-00382B	PMO-BUSHING FEED	5	SA	
5.4-83	JC66-00598A	ROLLER-FEED	1	SA	
5.4-84	JC66-01648A	ACTUATOR-EMPTY	1	SA	
5.4-85	JC63-01617A	GROUND-PICK_UP	1	SA	
5.4-86	JC63-00527A	SHEET-BRUSH	1	SA	
5.4-87	JC75-00095A	MEC-BRUSH PICK UP	1	SNA	
5.4-88	JC61-02268A	BRACKET-COVER FRONT	1	SA	
5.4-89	JC63-01676A	GROUND-BRUSH PICK UP	1	SA	
5.4-90	JC61-02306A	GUIDE-PAPER	1	SA	
5.4-91	JC61-02400A	GUIDE FRONT PAPER	1	SA	
5.4-92	JC61-02305A	GUIDE-TR_RIB	1	SA	
5.4-93	JC61-00604A	PLATE-E_SAW	1	SA	
5.4-94	JC61-02307A	GUIDE-TR	1	SA	
5.4-95	JC61-02196A	GUIDE-INPUT	1	SA	
5.4-96	JC61-02236A	PLATE EARTH TRANSFER	1	SA	
5.4-97	JC66-01654A	SHAFT-FEED IDLE	1	SA	
5.4-98	JC61-00585A	BUSH-M-FEED IDLE	2	SA	
5.4-99	JC61-70958A	SPRING ETC-TR	2	SA	
5.4-100	JC61-00914A	PLATE-P-PUSH BUSHING	2	SA	
5.4-101	JC72-00984A	PMO-PLATE GUIDE DEVE_L	1	SA	
5.4-102	JC61-70932A	SPRING ETC-GUIDE DEVE	2	SA	
5.4-103	JC72-00985A	PMO-PLATE GUIDE DEVE_R	1	SA	
5.4-104	6107-001370	SPRING TR	1	SA	
5.4-105	JC61-02468A	BUSH-TR_L	1	SA	
5.4-106	JC65-00033A	TERMINAL SPRING TR	1	SA	
5.4-107	JC61-00588A	PMO-BUSHING_TR(L)	1	SA	
5.4-108	JC61-02304A	GUIDE-HOLDER_TR	1	SA	
5.4-109	JC61-00553A	SPRING ETC-ES (Guide holder TR)	1	SA	
5.4-110	JC61-02231A	HOLDER-TRANSFER	1	SA	
5.4-111	JC66-01649A	LINK-COVER_REAR	1	SA	

## Frame Parts List

SA : SERVICE AVAILABLE, SNA : SERVICE not AVAILABLE

Drawer#	SEC_Code	Description	QT'y	Service	Remark
5.4-112	6107-001172	SPRING-CS	1	SA	
5.4-114	JC97-03067A	MEA UNIT-GUIDE REAR	1	SA	
5.4-115	JC61-00424A	BUSH-4	1	SNA	
5.4-116	JC39-00856A	HARNESS-CCD HOME	1	SA	
5.4-117	JC39-00945A	HANESS-FUSER SMPS	1	SA	

### 5.5 Main Drive

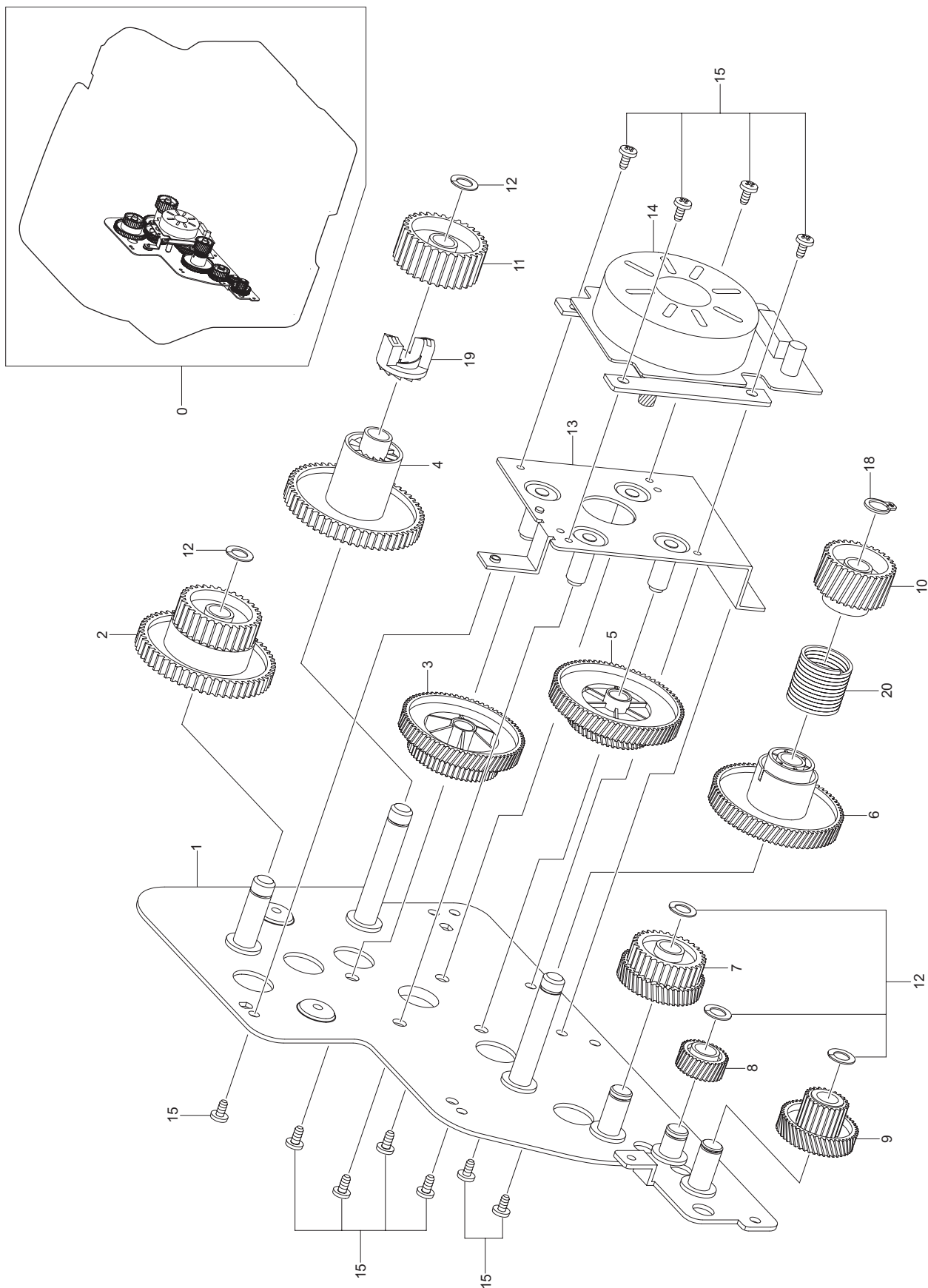

## Main Drive Parts List

SA : SERVICE AVAILABLE, SNA : SERVICE not AVAILABLE

Drawer#	SEC_Code	Description	QT'y	Service	Remark
5.5-0	JC96-04731A	ELA UNIT-DRIVE	1	SA	
5.5-1	JC61-02195A	BRACKET-GEAR	1	SNA	
5.5-2	JC66-01641A	GEAR-EXIT RDCN 61/28	1	SA	
5.5-3	JC66-01628A	GEAR-RDCN 83/40	1	SA	
5.5-4	JC66-01632A	GEAR-FUSER DR IN 61	1	SA	
5.5-5	JC66-01626A	GEAR-RDCN 89/55	1	SA	
5.5-6	JC66-01633A	GEAR-OPC DR IN 89	1	SA	
5.5-7	JC66-01625A	GEAR-FEED RDCN 56/25	1	SA	
5.5-8	JC66-01640A	GEAR-PICKUP IDLE 31	1	SA	
5.5-9	JC66-01650A	GEAR-RDCN 52/18	1	SA	
5.5-10	JC66-01798A	GEAR-OPC CLUTCH 29	1	SA	
5.5-11	JC66-01637A	GEAR-FUSER DR OUT 37	1	SA	
5.5-12	6031-000023	WASHER-PLAIN	5	SNA	
5.5-13	JC61-02227A	BRACKET-MOTOR	1	SNA	
5.5-14	JC31-00090A	MOTOR BLDC	1	SNA	
5.5-15	6003-000269	SCREW-TAPTITE	11	SA	
5.5-18	6044-001130	RING-C	1	SNA	
5.5-19	JC66-00340A	GEAR HUB CLUTCH	1	SNA	
5.5-20	6107-001372	SPRING CLUTCH	1	SNA	

## 5.6 Scan Ass'y

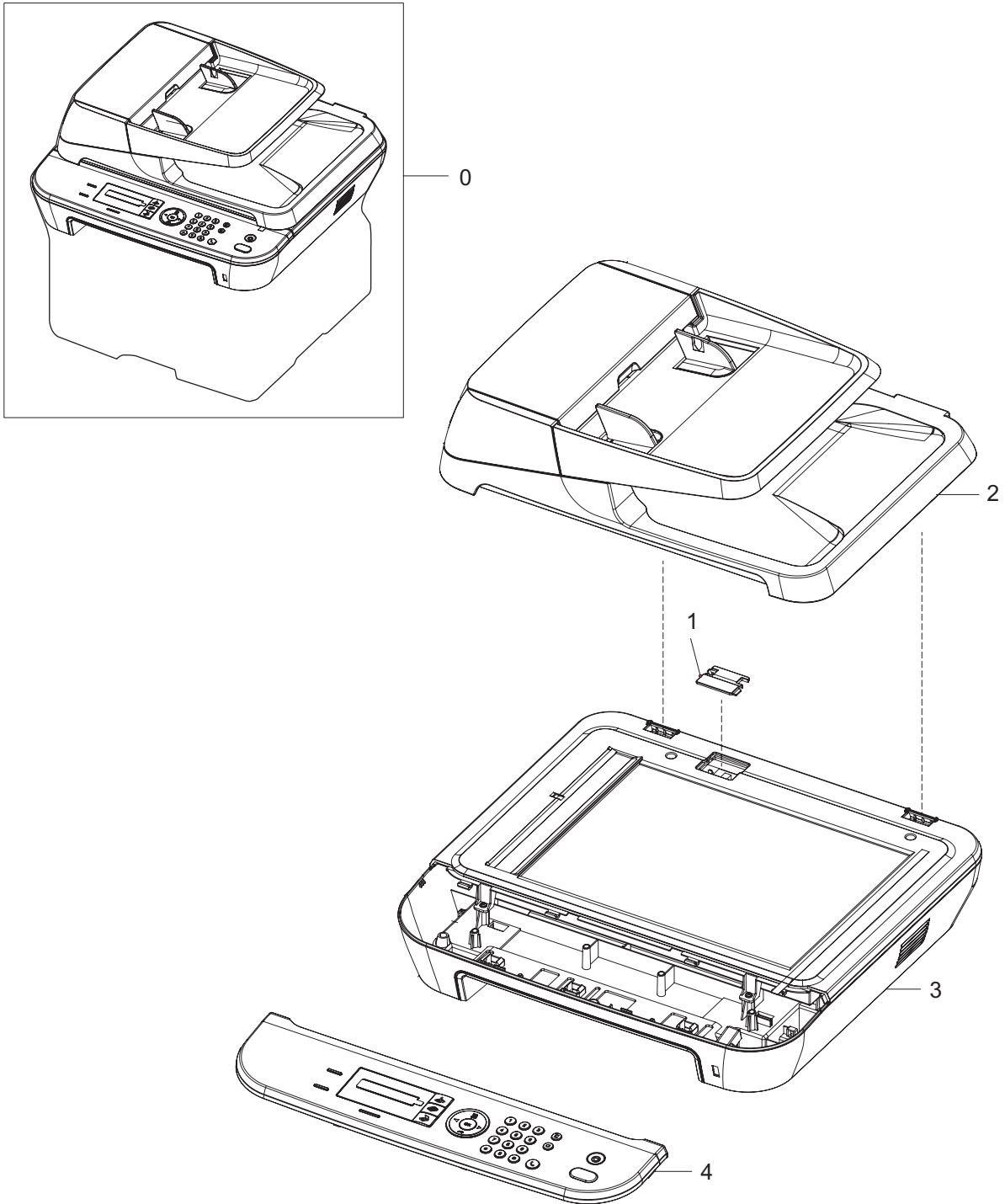

## Scan Ass'y Parts List

SA : SERVICE AVAILABLE, SNA : SERVICE not AVAILABLE

Drawer#	SEC_Code	Description	QT'y	Service	Remark
5.6-0	JC96-05074D	ELA HOU-SCAN_HIGH	1	SA	SCX-4828FN
	JC96-05461A	ELA HOU-SCAN_LOW	1	SA	SCX-4824FN
5.6-1	JC67-00304A	CAP-ADF CONNECTOR	1	SNA	
5.6-2	JC96-05091A	ELA HOU-ADF	1	SA	
5.6-3	JC96-05095A	ELA HOU-PLATEN_HIGH	1	SA	SCX-4828FN
	JC96-05097A	ELA HOU-PLATEN_LOW	1	SA	SCX-4824FN
5.6-4	JC96-05094D	ELA HOU-OPE	1	SA	SCX-4828FN
	JC96-05460A	ELA HOU-OPE	1	SA	SCX-4824FN

## 5.7 ADF Ass'y

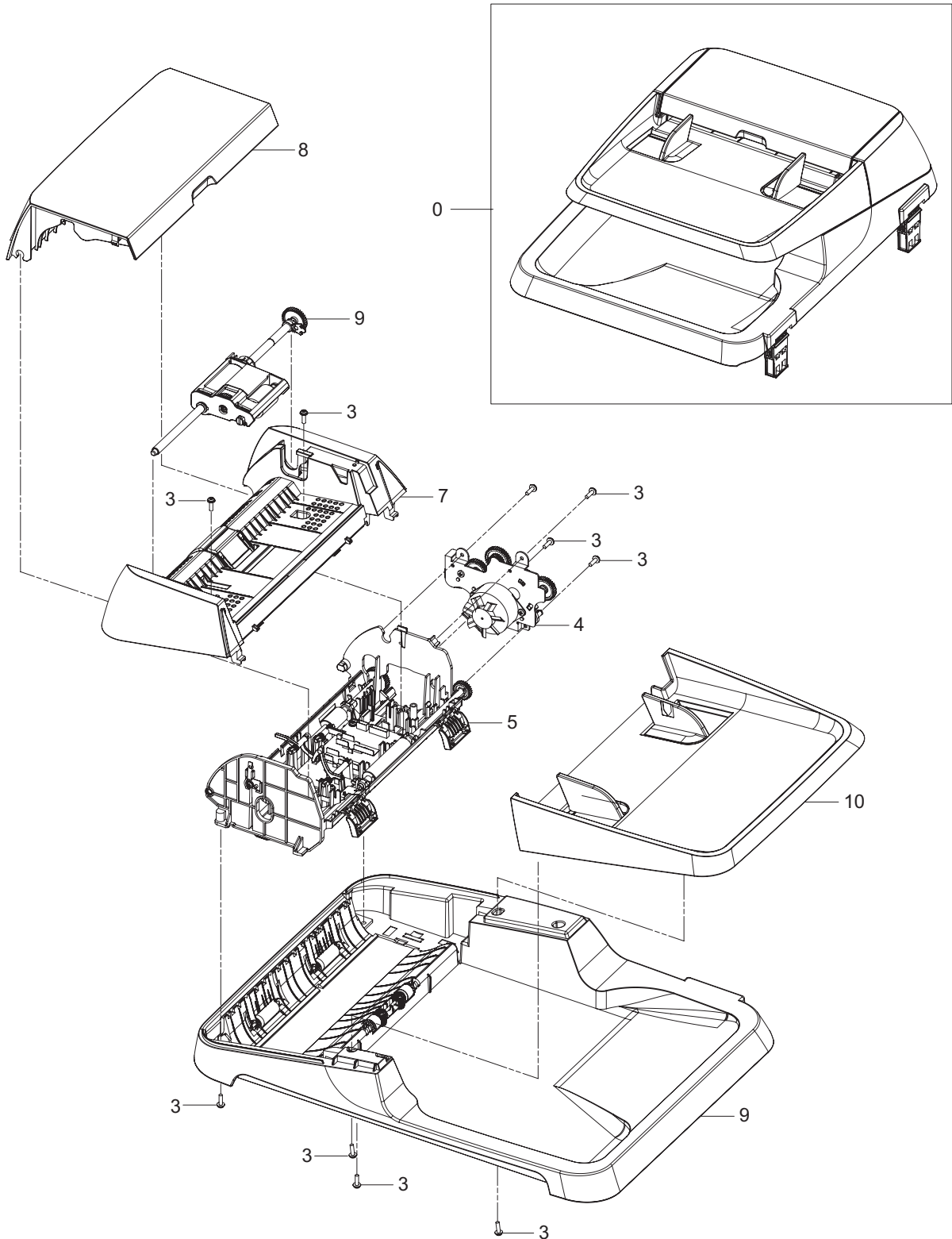

## ADF Ass'y Parts List

SA : SERVICE AVAILABLE, SNA : SERVICE not AVAILABLE

Drawer#	SEC_Code	Description	QT'y	Service	Remark
5.7-0	JC96-05091A	ELA HOU-ADF	1	SA	
5.7-3	6003-000196	SCREW-TAPTITE	10	SA	
5.7-4	JC96-05092A	ELA HOU-ADF MOTOR	1	SA	
5.7-5	JC96-05093A	ELA HOU-ADF LOWER	1	SA	
5.7-6	JC97-01962A	MEA UNIT-PICKUP DELL	1	SA	
5.7-7	JC97-03223A	MEA-ADF UPPER	1	SA	
5.7-8	JC97-03224A	MEA-COVER OPEN	1	SA	
5.7-9	JC97-03225A	MEA-COVER PLATEN	1	SA	
5.7-10	JC97-03226A	MEA-TX STACKER	1	SA	



## 5.8 Platen Ass'y

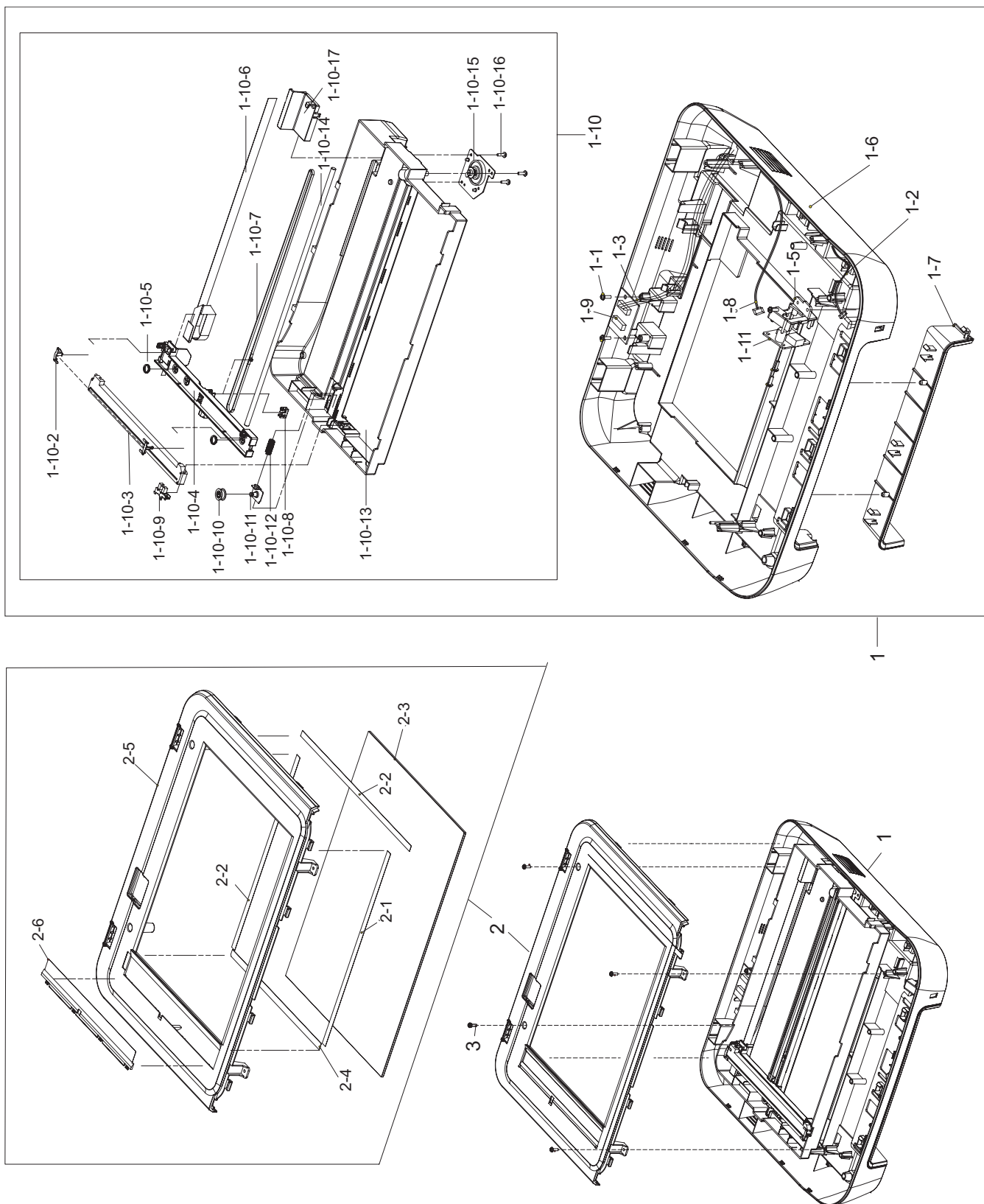

## Platen Ass'y Parts List

SA : SERVICE AVAILABLE, SNA : SERVICE not AVAILABLE

Drawer#	SEC_Code	Description	QT'y	Service	Remark
5.8-1	JC96-05096A	ELA HOU-SCAN LOWER_H	1	SA	SCX-4828FN
	JC96-05098A	ELA HOU-SCAN LOWER_L	1	SA	SCX-4824FN
5.8-1-1	6003-000196	SCREW-TAPTITE	9	SA	
5.8-1-2	JC39-00944A	HARNESS-OPE	1	SA	
5.8-1-3	JC39-00948A	HARNESS-ADF LOWER	1	SNA	
5.8-1-4	JC39-00951A	FLAT CABLE	1	SNA	
5.8-1-5	JC61-02575A	HOLDER-USB	1	SNA	
5.8-1-6	JC63-01922A	COVER-SCAN LOWER	1	SNA	
5.8-1-7	JC63-01929A	COVER-MIDDLE DECO	1	SNA	
5.8-1-8	JC39-00953A	HARNESS-USB HOST	1	SNA	SCX-4828FN
5.8-1-9	JC92-02033A	PBA-JOINT	1	SNA	
5.8-1-10	JC96-05131A	ELA UNIT-STANDARD SCAN	1	SNA	
5.8-1-10-2	JC66-01580A	SLIDER-CIS	2	SA	
5.8-1-10-3	0609-001305	CONTACT IMAGE SENSOR	1	SA	
5.8-1-10-4	JC61-02506A	BRACKET-CIS	1	SNA	
5.8-1-10-5	6107-001137	SPRING-CS	2	SA	
5.8-1-10-6	JC39-00951A	FLAT CABLE	1	SNA	
5.8-1-10-7	6602-001637	BELT-TIMING GEAR	1	SA	
5.8-1-10-8	JB61-00232A	CLIP-P-BELT	1	SA	
5.8-1-10-9	0604-001095	PHOTO-INTERRUPTER	1	SA	
5.8-1-10-10	JC66-00713A	PULLEY-M_IDLE	1	SNA	
5.8-1-10-11	JC61-00931A	BRACKET-P-PULLEY	1	SNA	
5.8-1-10-12	6107-001194	SPRING-CS	1	SA	
5.8-1-10-13	JC61-02517A	FRAME-SCAN LOWER	1	SNA	
5.8-1-10-14	JC66-01448A	SHAFT-CIS	1	SA	
5.8-1-10-15	JC96-05013A	ELA UNIT-SCAN DRIVE	1	SNA	
5.8-1-10-16	6003-000196	SCREW-TAPTITE	3	SA	
5.8-1-10-17	JC63-01803A	COVER-FFC	1	SNA	
5.8-1-11	JC92-02065A	PBA-USB HOST	1	SA	SCX-4828FN
5.8-2	JC97-03227A	MEA-SCAN UPPER	1	SA	
5.8-2-1	0203-001266	TAPE-DOUBLE FACE	1	SNA	
5.8-2-2	0203-001267	TAPE-DOUBLE FACE	2	SNA	
5.8-2-3	JB01-00002A	GLASS-PLATEN	1	SA	
5.8-2-4	JC63-01906A	SHEET-SHADING	1	SNA	
5.8-2-5	JC63-01923A	COVER-SCAN UPPER	1	SNA	
5.8-2-6	JC97-03237A	MEA HOU-ADF SHEET	1	SA	

## 5.9 OPE Unit

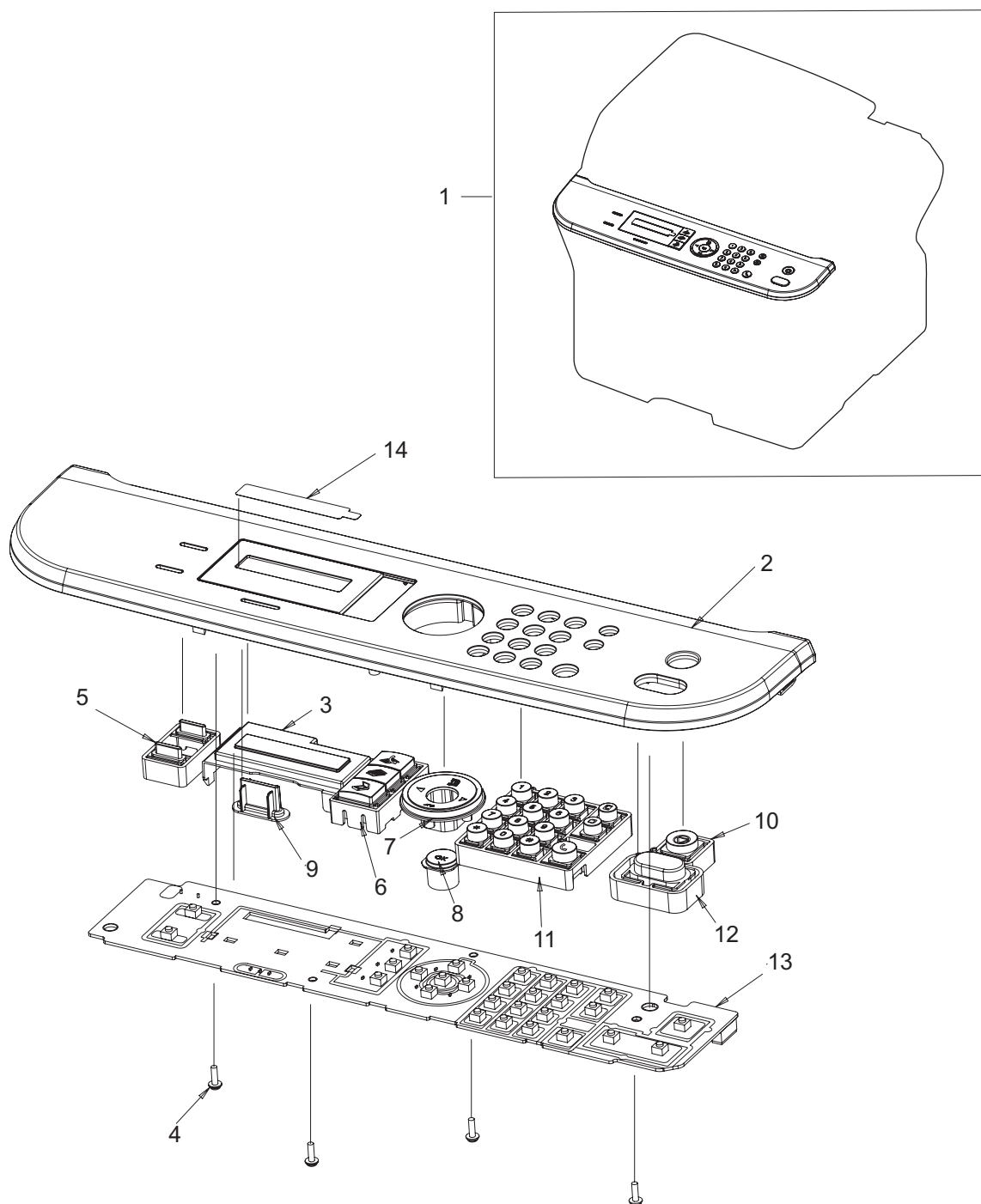

## OPE Unit Parts List

SA : SERVICE AVAILABLE, SNA : SERVICE not AVAILABLE

Drawer#	SEC_Code	Description	QT'y	Service	Remark
5.9-1	JC96-05094Q	ELA HOU-OPE	1	SA	
5.9-2	JC63-01924Q	COVER-OPE	1	SNA	
5.9-3	JC63-00076A	COVER-WINDOW SF-530	1	SNA	
5.9-4	6003-000196	SCREW-TAPTITE	4	SA	
5.9-5	JC64-00386A	KEY-EXTRA	1	SNA	
5.9-6	JC64-00387A	KEY-FAX	1	SNA	
5.9-7	JC64-00388A	KEY-MENU	1	SNA	
5.9-8	JC64-00389A	KEY-OK	1	SNA	
5.9-9	JC64-00392A	KEY-STATUS	1	SNA	
5.9-10	JC64-00393A	KEY-STOP	1	SNA	
5.9-11	JC64-00394A	KEY-TEL	1	SNA	
5.9-12	JC64-00410A	KEY-START	1	SA	
5.9-13	JC92-02019A	PBA SUB-OPE	1	SA	
5.9-14	JC63-01802A	COVER-LCD	1	SNA	

## 5.10 Duplex Unit(Only SCX-4828FN)

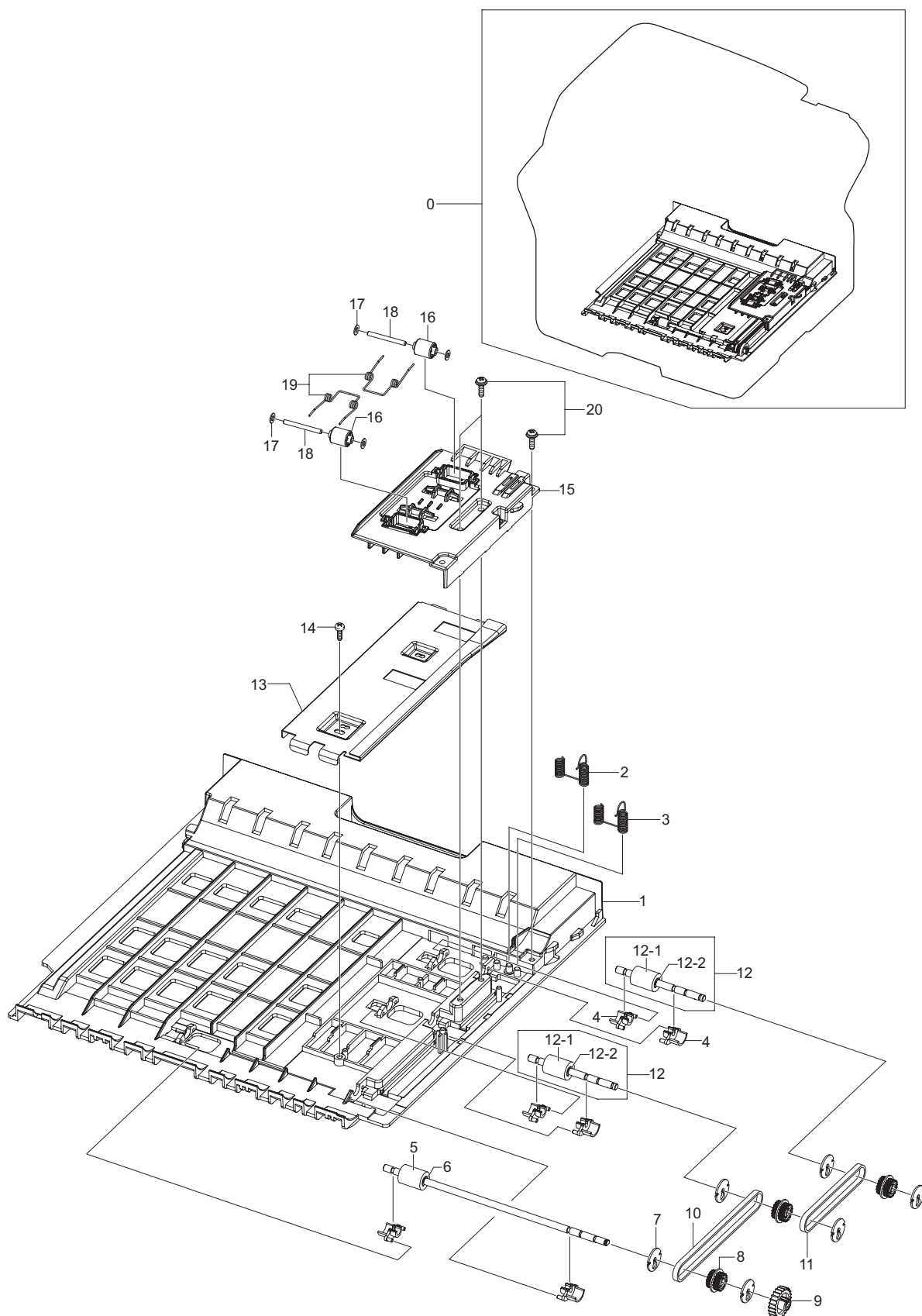

## Duplex Unit(Only SCX-4828FN) Parts List

SA : SERVICE AVAILABLE, SNA : SERVICE not AVAILABLE

Drawer#	SEC_Code	Description	QT'y	Service	Remark
5.10-0	JC96-04736A	ELA UNIT-DUPLEX	1	SA	
5.10-1	JC61-02188A	FRAME-DUPLEX_BASE	1	SNA	
5.10-2	JC65-00036A	TERMINAL-GND_DUP L	1	SA	
5.10-3	JC65-00035A	TERMINAL-GND_DUP S	1	SA	
5.10-4	JC61-00665A	BUSH-M-FEED, DUP	6	SA	
5.10-5	JC66-01657A	ROLLER-FEED_DUP2	1	SNA	
5.10-6	6044-000107	RING-C	1	SNA	
5.10-7	JC66-00900A	PULLEY-M-18-DUMMY_DUP	6	SA	
5.10-8	JC66-00899A	PULLEY-18_DUP	3	SA	
5.10-9	JC66-00038A	GEAR-EXIT F/DOWN	1	SA	
5.10-10	6602-001589	BELT-TIMING GEAR	1	SA	
5.10-11	6602-001588	BELT-TIMING GEAR	1	SA	
5.10-12	JC96-04983A	ELA UNIT-ROLLER_DUP	2	SNA	
5.10-12-1	JC66-00901A	ROLLER-FEED_DUP	1	SA	
5.10-12-2	6044-000107	RING-C	1	SNA	
5.10-13	JC61-02235A	BRACKET-DUPLEX_ALIGN	1	SNA	
5.10-14	6002-000440	SCREW-TAPPING	1	SNA	
5.10-15	JC61-02314A	GUIDE-DUPLEX_UPPER	1	SNA	
5.10-16	JC66-00896A	ROLLER-M-IDLE_DUP	2	SA	
5.10-17	JK72-00058A	PCT-SILP WASHER	4	SNA	
5.10-18	JC66-00444A	SHAFT-IDLE ROLL, DUP	2	SA	
5.10-19	6107-001156	SPRING-TS	2	SA	
5.10-20	6003-000196	SCREW-TAPTITE	3	SNA	

## 5.11 Fuser

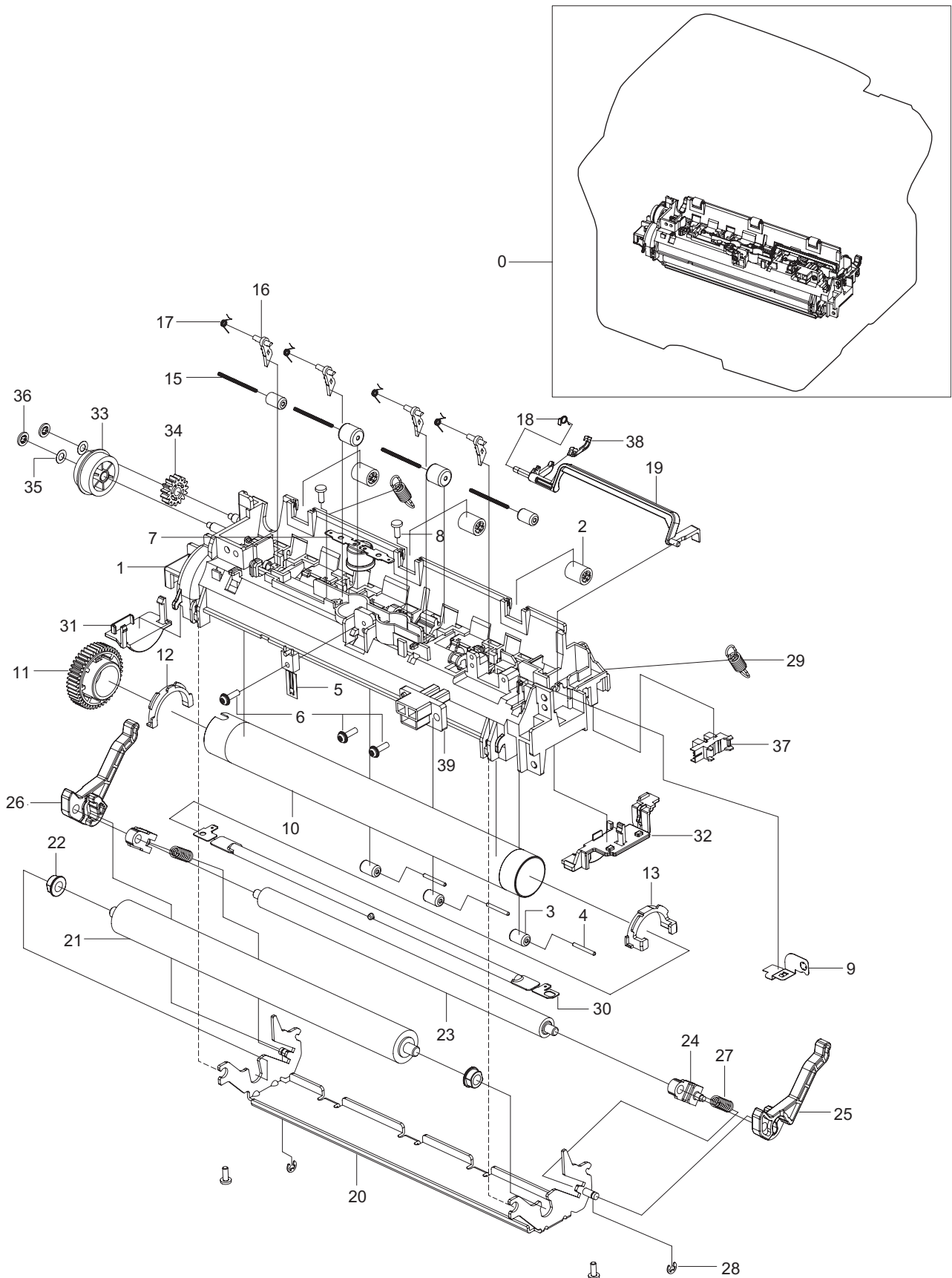

## Fuser Parts List

SA : SERVICE AVAILABLE, SNA : SERVICE not AVAILABLE

Drawer#	SEC_Code	Description	QT'y	Service	Remark
5.11-0	JC96-05132A	ELA UNIT-FUSER	1	SA	220V
	JC96-05133A	ELA UNIT-FUSER	1	SA	110V
5.11-1	JC63-01917A	COVER-FUSER	1	SNA	
5.11-2	JC72-40981A	PMO-ROLLER UPPER DP	3	SA	
5.11-3	JC66-01312A	ROLLER-IDLE	5	SA	
5.11-4	JC70-20901A	IEX-SHAFT IDLE,F/UP	3	SA	
5.11-5	1404-001364	THERMISTOR-NTC ASSY	1	SA	
5.11-6	6003-000196	SCREW-TAPTITE	3	SA	
5.11-7	4712-001031	THERMOSTAT	1	SA	
5.11-8	6003-000282	SCREW-TAPTITE	4	SNA	
5.11-9	JC63-01536A	GROUND-FUSER	1	SNA	
5.11-10	JC66-01256B	ROLLER-HEAT	1	SA	
5.11-11	JC66-01254A	GEAR-FUSER	1	SA	
5.11-12	JC61-02334A	BUSH-HR-L	1	SNA	
5.11-13	JC61-02335A	BUSH-HR-R	1	SNA	
5.11-14	JC72-20902A	PEX-ROLLER F/UP(2)	2	SA	
5.11-15	6107-001359	SPRING-ETC	4	SA	
5.11-16	JC61-02538A	GUIDE-CLAW	4	SNA	
5.11-17	JC61-01950A	SPRING ETC-CLAW	4	SA	
5.11-18	6107-001165	SPRING-TS	1	SA	
5.11-19	JC66-01595A	ACTUATOR-EXIT	1	SNA	
5.11-20	JC61-02197A	FRAME-FUSER	1	SNA	
5.11-21	JC66-01663A	ROLLER-PRESSURE	1	SA	
5.11-22	JC61-02336A	BUSH-PR-1ST	2	SNA	
5.11-23	JC66-01664A	ROLLER-PRESSURE_2ND	1	SA	
5.11-24	JC61-02337A	BUSH-PR-2ND	2	SNA	
5.11-25	JC66-01598A	LEVER-LINK JAM_R	1	SNA	
5.11-26	JC66-01597A	LEVER-LINK JAM_L	1	SA	
5.11-27	6107-001246	SPRING-CS	2	SA	
5.11-28	6044-000159	RING-C	2	SA	
5.11-29	6107-001361	SPRING-ES	2	SA	
5.11-30	4713-001212	LAMP-HALOGEN	1	SA	220V
	4713-001211	LAMP-HALOGEN	1	SA	110V
5.11-31	JC67-00266A	CAP-LAMP_L	1	SNA	
5.11-32	JC67-00267A	CAP-LAMP_R	1	SNA	
5.11-33	JC66-01638A	GEAR-FUSER RDCN 28-20	1	SA	
5.11-34	JC66-00056A	GEAR-MPF 5	1	SNA	
5.11-35	6031-001051	WASHER-PLAIN	2	SNA	



## Fuser Parts List

SA : SERVICE AVAILABLE, SNA : SERVICE not AVAILABLE

Drawer#	SEC_Code	Description	QT'y	Service	Remark
5.11-36	6044-000001	RING-CS	2	SNA	
5.11-37	0604-001095	PHOTO-INTERRUPTER	1	SA	
5.11-38	JC61-02520A	PLATE-ACTUATOR	1	SNA	
5.11-39	JC39-00946A	HARNESS-FUSER AC	1	SNA	
5.11-40	JC39-00819A	HARNESS-FUSER JOINT	1	SA	
5.11-41	JC39-00823A	HARNESS-EXIT SENSOR	1	SA	

## 5.12 Cassette

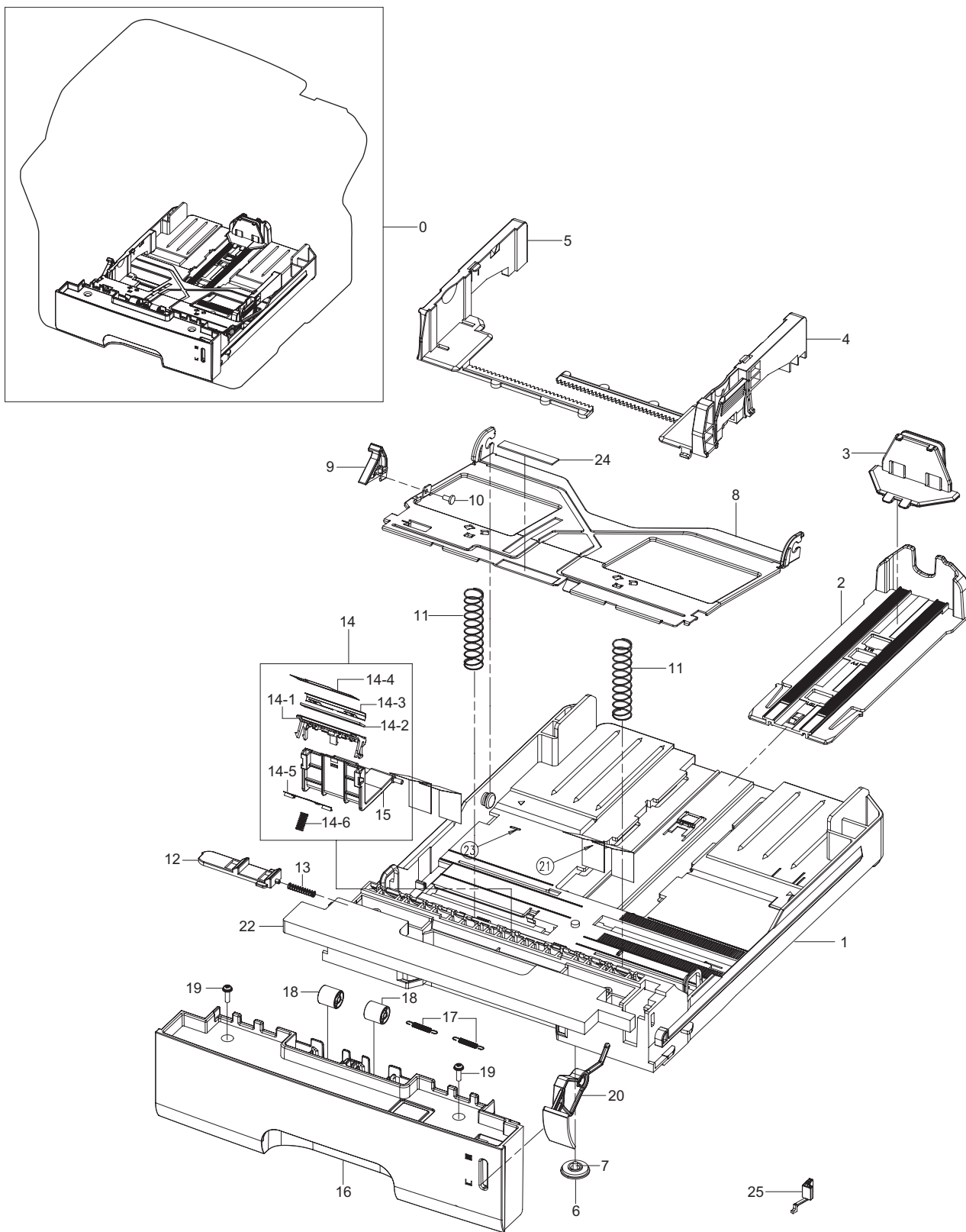

## Cassette Parts List

SA : SERVICE AVAILABLE, SNA : SERVICE not AVAILABLE

Drawer#	SEC_Code	Description	QT'y	Service	Remark
5.12-0	JC97-03017A	MEA UNIT-CASSETTE	1	SA	
5.12-1	JC61-00876A	FRAME-M_CASSETTE	1	SA	
5.12-2	JC61-00918B	GUIDE-M-EXTENSION L2	1	SA	
5.12-3	JC72-00971A	PMO-EXTENSION SMALL	1	SA	
5.12-4	JC70-00301A	ADJUST-M-CASSETTE_R	1	SA	
5.12-5	JC70-00300A	ADJUST-M-CASSETTE_L	1	SA	
5.12-6	JG66-40003A	GEAR-PINION	1	SA	
5.12-7	6003-000264	SCREW-TAPTITE	1	SA	
5.12-8	JC61-00603A	PLATE-P-KNOCK_UP	1	SA	
5.12-9	JC66-00719A	CAM-M-KNOCK UP	1	SA	
5.12-10	6003-000261	SCREW-TAPTITE	1	SA	
5.12-11	6107-001166	SPRING-CS	2	SA	
5.12-12	JC72-00972A	PMO-PLATE_LOCKER	1	SA	
5.12-13	JG61-70531A	SPRING ETC-LOCKER,PLATE	1	SA	
5.12-14	JC96-04743A	ELA HOU-HOLDER_PAD	1	SA	
5.12-14-1	JC61-02159A	HOLDER-PAD	1	SNA	
5.12-14-2	JC73-00140A	RPR-FRICTION PAD	1	SNA	
5.12-14-3	JC61-02237A	PLATE-PAD	1	SNA	
5.12-14-4	JC63-01669A	SHEET PAD	1	SNA	
5.12-14-5	JC63-01205A	GROUND-PAD	1	SNA	
5.12-14-6	JC61-70911A	SPRING ETC-EXIT ROLL FD	1	SNA	
5.12-15	JC61-01978A	HOUSING-HOLDER PAD	1	SA	
5.12-16	JC63-01531A	COVER-HANDLE_CASSETTE	1	SA	
5.12-17	6107-001047	SPRING-ES	2	SA	
5.12-18	JC66-00529A	ROLLER-M-IDLE FEED	2	SA	
5.12-19	6003-000196	SCREW-TAPTITE	2	SA	
5.12-20	JC64-00353A	INDICATOR-PAPER	1	SA	
5.12-21	JC63-01670A	SHEET-GUIDE_SIDE_FAR	4	SA	
5.12-22	JC72-01442A	SPONGE CST TOP	1	SA	
5.12-23	JC61-01692A	SUPPORT-HOLDER PAD	1	SA	
5.12-24	JC73-00141A	RPR-PAD CASSETTE	1	SA	
5.12-25	JC61-02484A	STOPPER-ADJUSTER	1	SA	

### 5.13 SCF

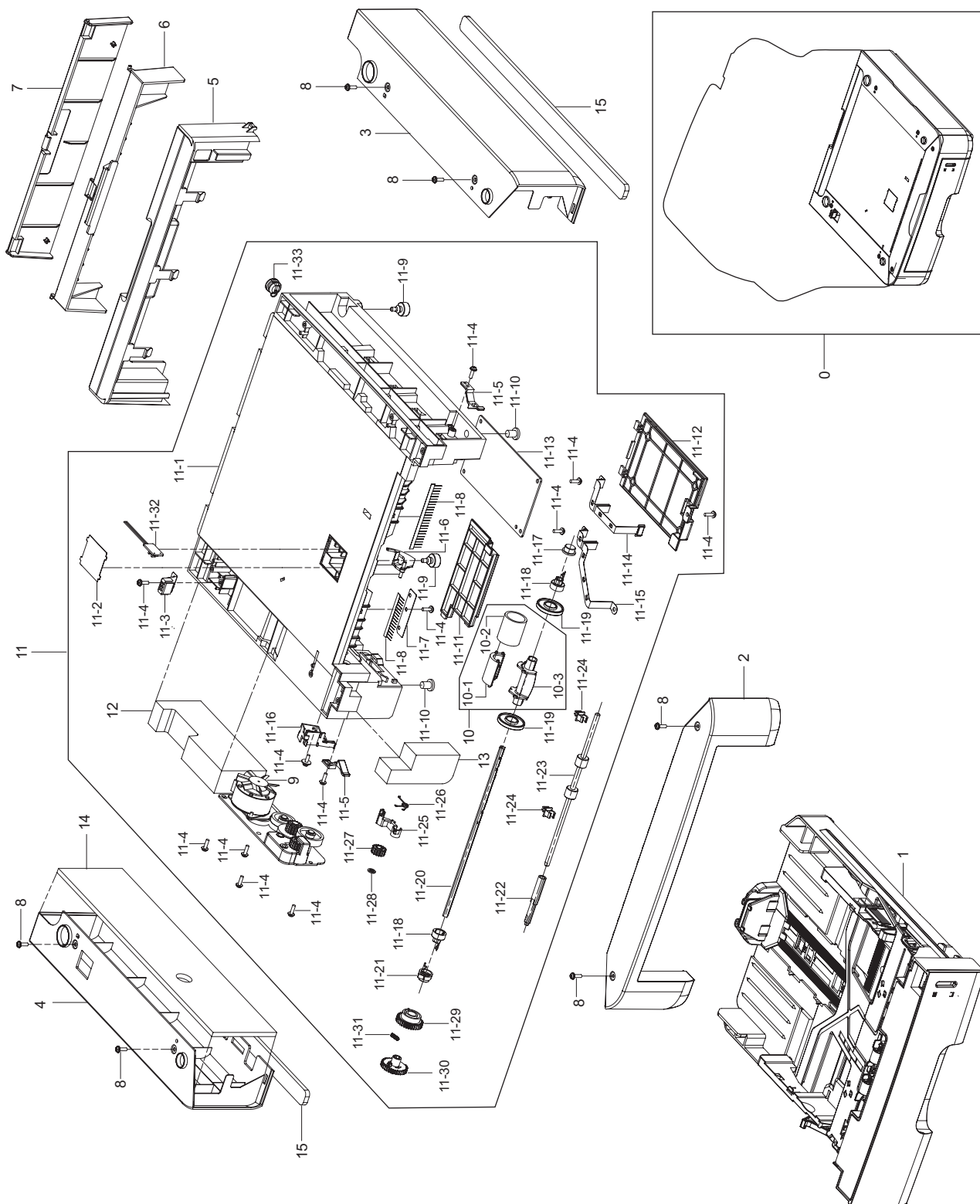

## SCF Parts List

SA : SERVICE AVAILABLE, SNA : SERVICE not AVAILABLE

Drawer#	SEC_Code	Description	QT'y	Service	Remark
5.13-0	JC96-05108A	ELA HOU-SCF	1	SNA	
5.13-1	JC97-03017A	MEA UNIT-CASSETTE	1	SNA	
5.13-2	JC63-01964A	COVER-FRONT_SCF	1	SNA	
5.13-3	JC63-01963A	COVER-RIGHT_SCF	1	SNA	
5.13-4	JC63-01962A	COVER-LEFT_SCF	1	SNA	
5.13-5	JC63-01608A	COVER-REAR_SCF	1	SA	
5.13-6	JC63-01650A	COVER-DUPLEX	1	SA	
5.13-7	JC63-01651A	COVER-REAR DUPLEX	1	SA	
5.13-8	6003-000196	SCREW-TAPTITE	6	SA	
5.13-9	JC96-04772A	ELA HOU-MOTOR_SCF	1	SA	
5.13-10	JC97-03062A	MEA UNIT-PICK UP	1	SA	
5.13-10-1	JC61-00909A	HOUSING-M-PICK UP_R2	1	SA	
5.13-10-2	JC73-00265A	SPONGE-ROLLER PICK UP	1	SA	
5.13-10-3	JC61-00910A	HOUSING-M-PICK UP2_R2	1	SA	
5.13-11	JC96-04771A	ELA HOU-FRAME_SCF	1	SA	
5.13-11-1	JC61-02189A	FRAME-SCF	1	SNA	
5.13-11-2	JC63-00369A	SHEET-COVER SENSOR	1	SA	
5.13-11-3	JC70-11028A	IPR-GROUND TOP	1	SA	
5.13-11-4	6003-000196	SCREW-TAPTITE	11	SA	
5.13-11-5	JC72-00983A	PMO-LOCKER CST	2	SA	
5.13-11-6	JC72-00975A	PMO-ACTUATOR EMPTY	1	SA	
5.13-11-7	JC63-00527A	SHEET-BRUSH	1	SA	
5.13-11-8	JC75-00095A	MEC-BRUSH ANTISTATIC	0.5	SA	
5.13-11-9	JC61-40001A	FOOT-ML80	2	SA	
5.13-11-10	JC61-00836A	FOOT-FRONT	2	SA	
5.13-11-11	JC63-01609A	COVER-HARNESSE_SCF	1	SNA	
5.13-11-12	JC63-00492A	COVER-M-SIMM R2	1	SA	
5.13-11-13	JC92-01911A	PBA-SCF	1	SA	
5.13-11-14	JC63-01635A	GROUND-BRUSH_SCF	1	SNA	
5.13-11-15	JC63-01636A	GROUND-PAPER_SCF	1	SNA	
5.13-11-16	JC33-00026A	SOLENOID-PICK UP	1	SA	
5.13-11-17	JC61-00587A	BUSH-M-PICK_UP R	1	SA	
5.13-11-18	JC61-00915A	STOPPER-M-PICK UP_R2	2	SA	
5.13-11-19	JC72-00982A	PMO-IDLE PICK_UP	2	SA	
5.13-11-20	JC66-01658A	SHAFT-PICK_UP_SCF	1	SNA	
5.13-11-21	JC61-00586A	BUSH-M-PICK_UP L	1	SA	
5.13-11-22	JC66-01653A	SHAFT-FEED_SCF	1	SNA	
5.13-11-23	JC66-00598A	ROLLER-FEED	1	SA	
5.13-11-24	JC72-00382B	PMO-BUSHING FEED	2	SA	

## SCF Parts List

SA : SERVICE AVAILABLE, SNA : SERVICE not AVAILABLE

Drawer#	SEC_Code	Description	QT'y	Service	Remark
5.13-11-25	JC66-00377A	CAM-M-PICK_UP	1	SA	
5.13-11-26	6107-001170	SPRING-TS	1	SA	
5.13-11-27	JC66-00394A	GEAR-FEED 2	1	SA	
5.13-11-28	6044-000001	RING-CS	1	SNA	
5.13-11-29	JC72-00979A	PMO-GEAR PICK_UP A	1	SA	
5.13-11-30	JC72-00980A	PMO-GEAR PICK_UP B	1	SA	
5.13-11-31	6107-001167	SPRING-CS	1	SA	
5.13-11-32	JC41-00133A	PCB-SENSOR	1	SNA	
5.13-11-33	JC61-00804A	BUSH-CABLE	1	SA	
5.13-12	JC72-01447A	SPONGE-SCF_FRAME	1	SNA	
5.13-13	JC72-01448A	SPONGE-SCF_FRONT	1	SNA	
5.13-14	JC72-01449A	SPONGE-SCF_GEAR	1	SNA	
5.13-15	JC72-01463A	SPONGE-SIDE SCF	2	SNA	
-	JC39-00920A	CBF HARNESS-SCF	1	SNA	
-	JC39-00859A	HARNESS-CLUTCH_JOINT	1	SNA	
-	JC39-00567A	CBF HARNESS-SYS_GND	1	SNA	
-	JC39-00228A	CBF HARNESS-GND	1	SNA	

# 6. System Diagram

## 6.1 Block Diagram

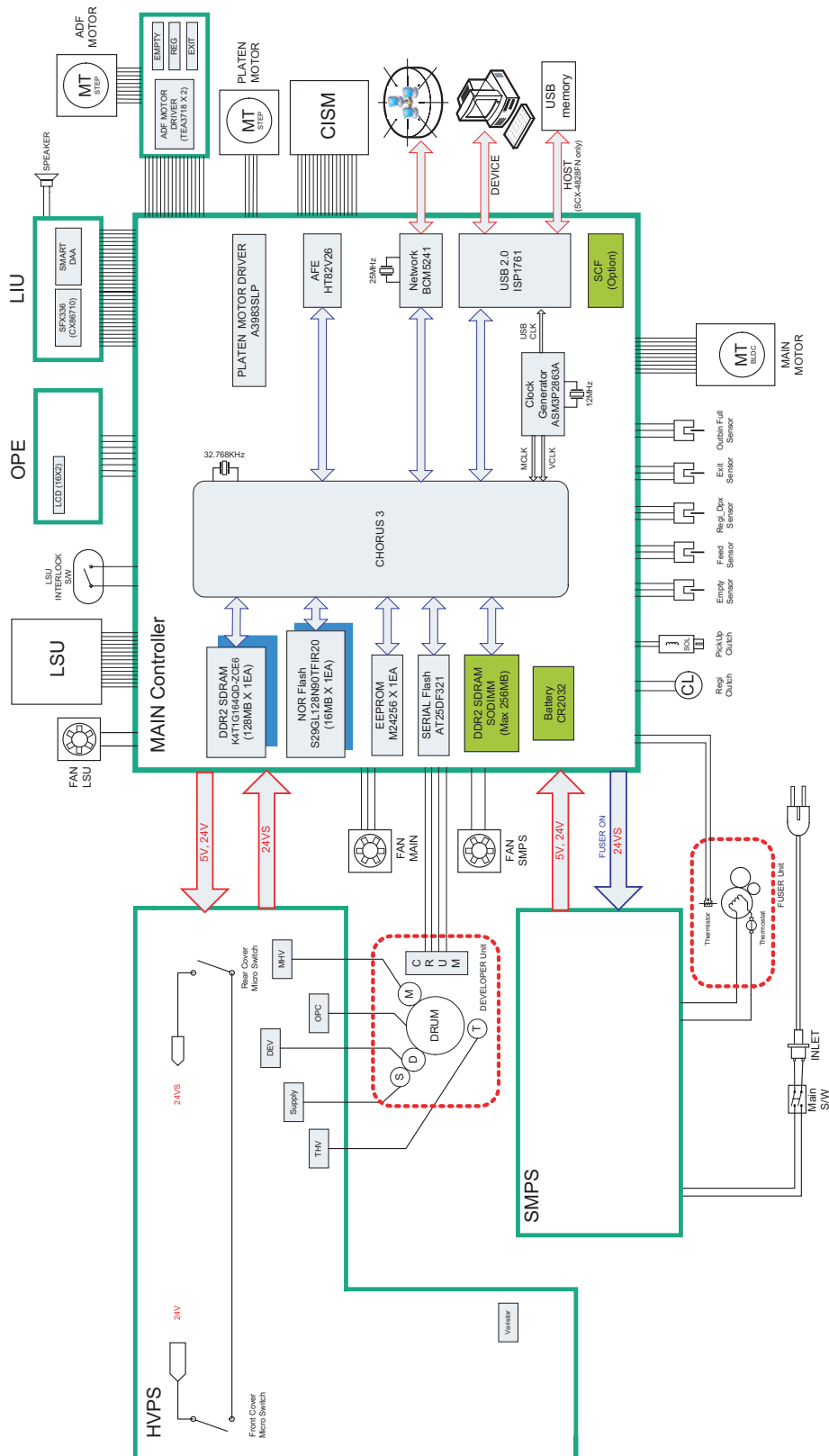

## 6.2 Connection Diagram

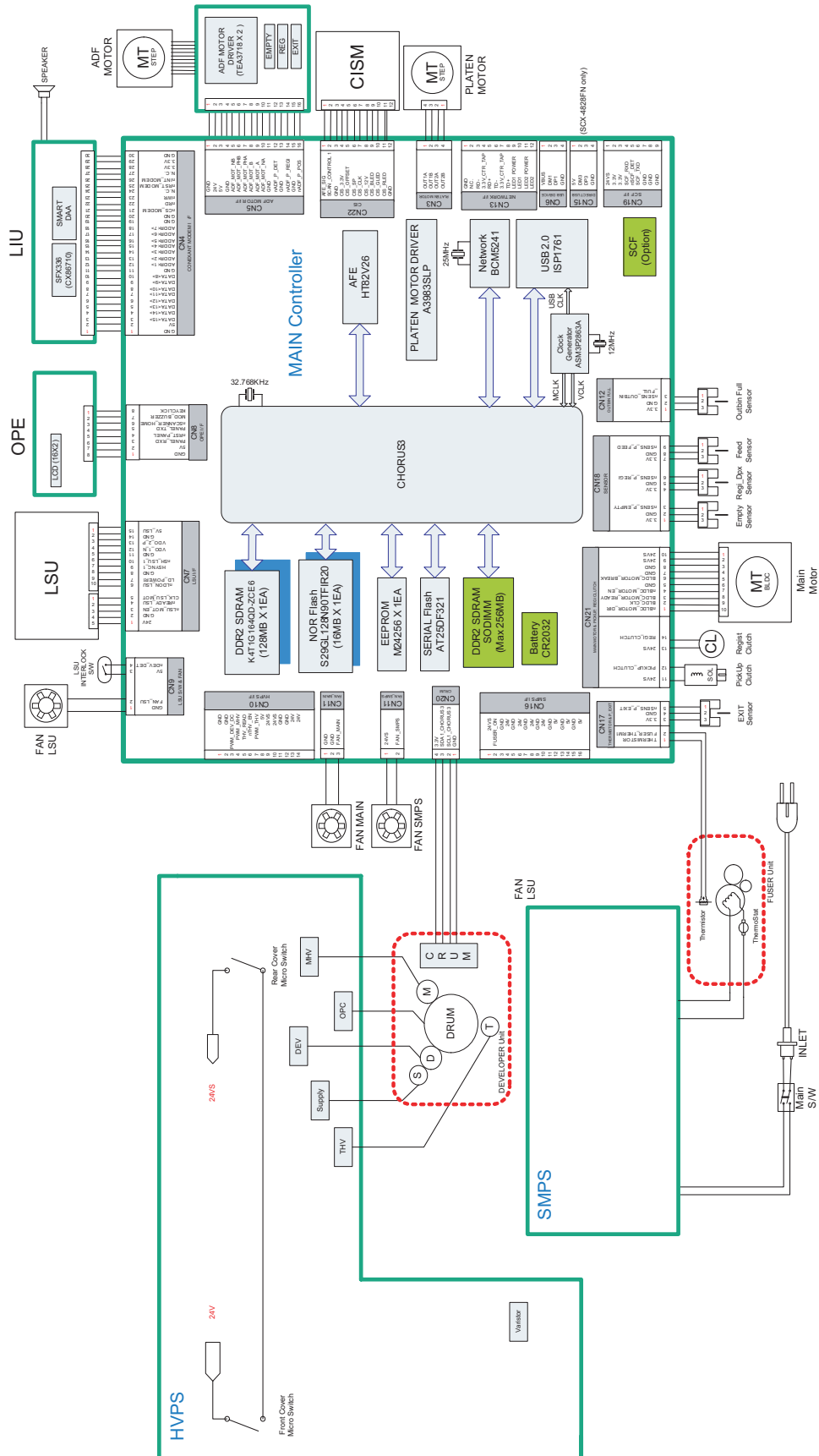



## 7. Reference Information

This chapter contains the tools list, list of abbreviations used in this manual, and a guide to the location space required when installing the printer. A definition of test pages and Wireless Network information definition is also included.

### 7.1 Tool for Troubleshooting

The following tools are recommended safe and easy troubleshooting as described in this service manual.

- **DVM (Digital Volt Meter)**

Standard : Indicates more than 3 digits.

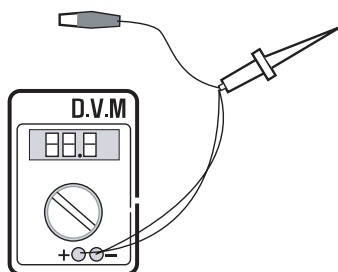

- **Driver**

Standard : "-" type, "+" type (M3 long, M3 short, M2 long, M2 short).

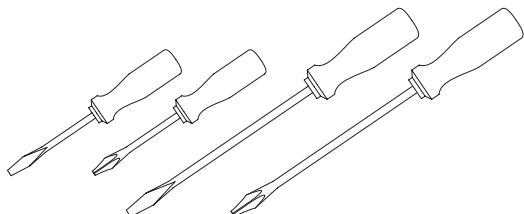

- **Tweezers**

Standard : For general home use, small type.



- **Cotton Swab**

Standard : For general home use, for medical service.



- **Cleaning Equipments**

Standard : An IPA (Isopropyl Alcohol) dry wipe tissue or a gentle neutral detergent and lint-free cloth.

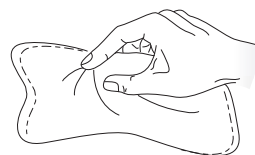

- **Vacuum Cleaner**

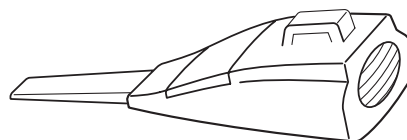

- **Spring Hook**

Standard : For general use



- **Software (Driver) installation CD ROM**

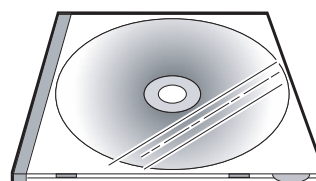

## 7.2 Acronyms and Abbreviations

The table below explains abbreviations used in this service manual.  
The contents of this service manual are declared with abbreviations in many parts. Please refer to the table.

### 7.2.1 Acronyms

ABS	Automatic Background Suppression(a kind of copy feature)	FDI	Foreign Device Interface
APF	Automatic Paper Feeder(Tray)	FIA	Foreign Interface Attachment
BOOTP	BOOTSTRAP PROTOCOL	FRU	Field Replaceable Unit
CCD	Charged Coupled Device	FPOT	First Print Out Time
CIS	Contact Image Sensor	GW	GateWay
CPM	Copies Per Minute	HH	High Temperature, High Humidity (Testing Chamber conditions)
CP	Control Panel(= OPE)	HPVC	Halftone Printing Video Controller in the SPGpM (Graphic Processor for Copy)
CQ	Copy Quality	IDC	International Data Corp.
CRU	Customer Replaceable Unit	IMAP	Internet Message Access Protocol
CRUM	CRU Memory	IPP	Internet Printing Protocols
CW	Center Ware	IPM	Images Per Minutes
CWDP	Center Ware Device Discovery Software(Samsung equivalent of Samsung's SyncThru)	IPX	Internetwork Packet Exchange
CWIS	Center Ware Internet Services	IQ	Image Quality
DADF	Duplex Auto Document Feeder (= DADH)	ITU	International Telecommunication Union
DC	Direct Connect	JBIG	Joint Binary Image Group (a kind of image data coding method)
DDNS	Dynamic Domain Name System	JPEG	Joint Photographic Expert Group (a kind of image data coding method)
DHCP	Dynamic Host Configuration Protocol	LCD	Liquid Crystal Display
DLC	Data Link Control	LEF	Long Edge Feeding
DNS	Domain Name System	LL	Low Temperature, Low Humidity (Testing Chamber conditions)
ECM	Error Correction Mode	LPR/LPD	Line Printer Daemon Protocols (LPR is a TCP-based protocol)
ECP	Enhanced Capability Port	LSU	Laser Scanning Unit
e-Coil	Extended Coil technology for Rapid(Fast) Fusing.	LUI	Local User Interface
EH&S	Samsung Environment, Health, & Safty	MCBF	Mean Copy Between Failure
ESMTP	Extended Simple Mail Transfer Protocol	MDSP	Multiple Document Single Printout
EP	Electro Photography	MFP	Multi-Functional Product
EPC	Electric Pre-Collation	MH	Modified Huffman (a kind of image data coding method)
FCOT	First Copy Out Time		

MIB	Management Information Base	RT-OS	Real Time Operating System
MIME	Multipurpose Internet Mail Extensions	RX	Receive
MR	Modified Read (a kind of image data coding method)	S2E	Scan-To-Email
MMR	Modified and Modified Read (a kind of image data coding method)	SAD	Solid Area Density
MN std	Multi-National Standard	SC	Service Call
MSOK	Master SOK(System Operation Key)	SCF	Second Cassette Feeder
MSO	Mixed Size Original	SDSP	Single Document Single Printout
MP	Multi Purpose	SDMP	Single Document Multiple Printout
MPBF	Mean Print Between Failure	SDR	Shut Down Rate
MSI	Multi Sheet Input	SEF	Short Edge Feeding
MTBF	Mean Time Between Failure	SIR	Sacrificed(or Standard) Image Reference
MTTR	Mean Time To Repair	SOK	System Operation Key
NCP	Network Control Protocol	sRGB	Standard RGB (Color Coordinate System)
NIC	Network Interface Card	SNMP	Simple Network Management Protocol
NOS	Network Operating System	TCP/IP	Transmission Control Protocol/Internet Protocol
NN	Normal Temperature, Normal Humidity (Testing Chamber conditions)	TBC(or tbc)	To Be Confirmed
NSDR	Non-Shut Down Rate(=USDR)	TBD(or tbd)	To Be Determined
NW	Network	TIFF	(Adobe & Aldus) Tagged Image File Format
OD	Optical Density	TRIM	Technical Retrofit Interim Maintenance
OHD	On Hook Dial	TTM	Time to Market
OSOK	Optional SOK(System Operation Key)	TX	Transmit
OP	Operational Procedure	UI	User Interface
PCL	Printer Control Language	UMC	Unit Manufacturing Cost
PDF	(Adobe) Portable Document Format	UMR	Unscheduled Maintenance Ratio
PPM	Pages Per Minutes	UPnP	Universal Plug and Play
PQ	Print Quality	USB	Universal Serial Bus
PS/3	PostScript Level-3	USDR	Un-Shut Down Rate(=NSDR)
PVC	Printing Video Controller in the SPGPm(Graphic Processor for Printer)	XCMI	Samsung's Management Information Base
QCD	Quality, Cost, and Delivery	WA	Warranty Action
RCP	Remote Control Panel	W x D x H	Width x Depth x Height

## 7.2.2 Service Parts

ACRONYM	EXPLANATION
ELA HOU-SCANNER ASS'Y	ELA=Electrical Assembly, HOU =Housing
MEA UNIT-COVER PA EXIT ASS'Y	MEA= Mechanical Assembly, PA=Paper
PMO-TRAY EXTENTION MP NE	PMO= Processing Mold MP=Multi-Purpose(Bypass) tray NE=for NEC (common as Samsung Halk printer)
MEC-CASSETTE ASS'Y(LETTER)	MEC = Mechanic Combined unit
COVER-M-FRONT	M=Mold
MPR-NAME/PLATE	MPR= Machinery Press,
UNIT-LSU	LSU =Laser Scanning Unit
SMPS-SMPS(V1)+HVPS	SMPS =Switching Mode Power Supply HVPS =High Voltage Power Supply
ELA-OPC UNIT SET	OPC=Organic Photo-Conductive
ELA HOU-MP ASS'Y	MP =Multi-Purpose (Bypass) tray
PBA MAIN-MAIN	PBA =Printed circuit Board Assembly
PMO-CONNECT PAPER MFP	MFP =Multi-Functional Peripheral
FAN-DC	DC =Direct Current
CBF POWER STITCH GRAY	CBF= Cable Form
MEA UNIT GUIDE CST PA ASS'Y	CST=Cassette(Paper tray), PA=Paper
PBA LIU	PBA =Printed circuit Board Assembly LIU =Line Interface Unit for FAX
SHIELD-P_MAIN LOWER	P=Press
CBF HARNESS-LIU GND	LIU =Line Interface Unit for FAX GND= Ground
PMO-COVER FEED AY	AY=Assembly
PMO-COVER BRKT MOTER	BRKT=Bracket
CBF HARNESS-LSU	LSU =Laser Scanning Unit
IPR-SHIELD SMPS UPPERI	IPR=Iron Press
PMO-BUSHING P/U.MP	P/U=Pickup MP=Multi-Purpose (Bypass) Tray
PMO-HOLDER GEAR TRr	TR= Transfer Roller
SPRING ETC-TR_L	TR_L=Transfer Roller - Left
PMO-CAM JAM REMOVE	PMO-CAM= Processing Mold-CAM
PMO-LOCKER DEVE	DEVE=Developer

ACRONYM	EXPLANATION
SPECIAL SCREW(PANNEL MFP)	MFP =Multi-Functional Peripheral
A/S MATERAL-DUMMY UPPER ASS'Y	A/S=After-Service
MCT-GLASS ADF	MCT= Machinery Cutting ADF=Automatic Document Feeder
PPR-REGISTRATION EDGE(F)	PPR= Processing Press
IPR-HOLDER GLASSI	PR=Iron Press
MCT-GLASS SCANNER(LLEGAL)	MCT= Machinery Cutting
CBF HARNESS-OPE	OPE=Operation Panel(Control Panel)
PBA SUB-D_SUB	PBA SUB-D_SUB =>Sub Printed circuit Board Assembly for the D-SUB type electrical connector (D-Sub) a kind of the connector type(shape 'D')
COVER-M-CCD CABLE	M=Mold CCD=Charge Coupled Device
COVER-SCAN LOWER(UMAX)	UMAX=> Supplier's name for CCD module
ICT-INSERT SHAFTI	ICT= Iron Cutting
IPR-BRK SCAN BD	IPR=Iron Press BRK=Bracket BD= Board
CBF SIGNAL-CCD FFC	CCD = Charge Coupled Device FFC =Flexible Flat Cable
COVER-M-OPE	M=Mold OPE=Operation Panel(Control Panel)
KEY-M-COPY	M=Mold
PLATE-M-ALPHA KEY	M=Molde ALPHA=Alphabet
PMO-GUIDE DP SIDE	DP=Duplex
RING-CS	CS= Compress
GEAR-MP/DUP DRV	MP =Multi-Purpose (Bypass) tray DUP DRV = Duplex Driver
IPR-BRKT G DUPI	PR=Iron Press BRKT=BRACKET G= Ground UP=Duplex
PMO-BUSHING TX(B4)	TX=Transmit
PMO-TRAY CASE, MP	MP=Multi-Purpose tray(Bypass tray)

ACRONYM	EXPLANATION
SPRING CS RE	CS=Compress RE=Rear
SPRING CS FR	CS=Compress FR=Front
PMO-BUSHING FINGER, F	F=Front
ICT-SHAFT-EXIT LOWER ID	ID=Idler
SPRING-EXIT ROLL FD	FD=Face Down
PMO-BUSHING_P/U,MP	P/U=Pickup MP =Multi-Purpose (Bypass) tray
PMO-HOLDER CAM MPF	MPF=Multi-Purpose Feeder(=MP)
PMO-GEAR P/U MPF	P/U=Pickup
MFP =Multi-Functional Peripheral	
RPR-RUBBER PICK UP,MP	RPR=Rubber Press
PBA SUB-MP SEN	PBA SUB-MP-SEN =>Sub Printed circuit Board Assembly for the MP-SEN(= Multi-Purpose (Bypass) tray-Sensor)
A/S MATERIAL-PICKUP,MP	
FOOT-ML80	
HOLDER CATCH CST MC2	MC2=>McKinley2 (Samsung Project code name)
IPR-GROUND PLATE A(OPC)	OPC=Organic Photo-Conductive
ELA M/M-AUD SPEAKER	ELA M/M => Electrical Assembly M/M AUD=Audio
CBF HARNESS-OPC GND	OPC GNG=Organic Photo-Conductive-Ground
IPR-GROUND PLATE SCF	SCF=Second Cassette Feeder(Tray2)
PBA SUB-PTL	PBA SUB-PTL=>Sub Printed circuit Board Assembly for the PTL(= Pre Transfer Lamp)
PBA SUB-FEED+P.EMP SEN.	PBA SUB-FEED=>Sub Printed circuit Board Assembly for the feeder EMP SEN=Empty Sensor
MOTOR STEP-MCK2(MAIN)	
GEAR-EXIT/U	EXIT/U=EXIT/Upper
GEAR-RDCN FEED INNER	RDCN=Reduction
CBF-HARNESS-MAIN-THV WIRE	THV =Transfer High Voltage
CBF-HARNESS-MAIN-MHV WIRE	MHV= High Voltage(Charge Voltage)

ACRONYM	EXPLANATION
GEAR-EXIT/U, ID	U=Upper ID=Idler
IPR-TERMINAL FU	FU=Fuser
PMO-BEARING H/R-F	H/R-F=Heat Roller - Front
BEARING-H/R L	H/R-L=Heat Roller -Left
PEX-ROLLER EXIT F_UP	PEX= Processing Extrude F_UP=Face Up
SPRING ETC-P/R	P/R=Pressure Roller
SPRING(R)-CAU-HOT-FU	CAU-HOT-FU = Caution Hot -Fuser
PMO-ARM ACTUATOR	PMO-ARM= Processing Mold Arm
LABEL(R)-HV FUSER	HV=High Voltage (220V)
LABEL(R)-LV FUSER	LV=Low Voltage (110V)
PPR-SPONG SHEET	PPR=Plastic Press
IPR-P_PINCH(SCAN)I	PR-P = Iron Press
ROLLER-REGI	REGI=Registration
PBA SUB-REGI	PBA SUB-REGI => Sub Printed circuit Board Assembly for the Registration
GROUND-P_SCAN ROLLER	GROUND-P =Ground-Press
IPR-GUARD C/O S/W	C/O = Cover Open S/W= Switch
MEA UNIT-TX STACKER	TX =Transmit
IPR-WASHER SPRING CU	CU=Curve

## 7.3 The Sample Pattern for the Test

The sample pattern shown in below is the standard pattern used in the factory.  
 The life of the toner cartridge and the printing speed are measured using the pattern shown below.  
 (The image is 70% of the actual A4 size).

### 7.3.1 A4 ISO 19752 Standard Pattern

This test page is reproduced at 70% of the normal A4 size

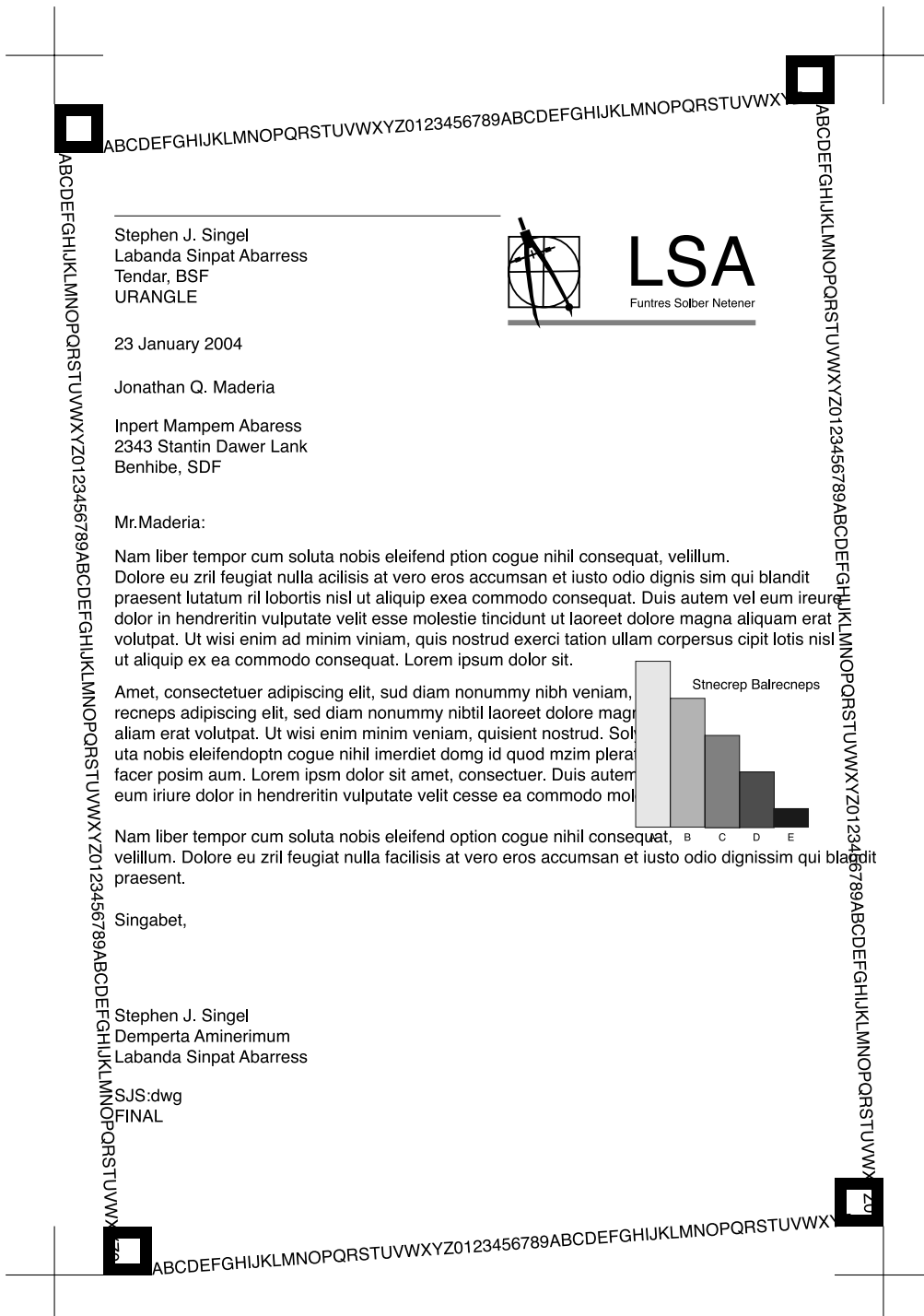



## 7.4 Selecting a location

Select a level, stable place with adequate space for air circulation. Allow extra space for opening covers and trays.

The area should be well-ventilated and away from direct sunlight or sources of heat, cold, and humidity. Do not set the machine close to the edge of your desk or table.

### Clearance space

- Front: 482.6 mm (enough space so that the paper tray can be removed)
- Back: 180 mm (enough space for ventilation)
- Right: 100 mm (enough space for ventilation)
- Left: 100 mm (enough space for ventilation)

