



North/Latin America
Europe/Africa
Asia/Oceania

Internal Use Only

<http://aic.lgservice.com>
<http://eic.lgservice.com>
<http://biz.lgservice.com>

LED LCD TV

SERVICE MANUAL

CHASSIS : LD12C

MODEL : 42LW650G/S/T/W 42LW659S
42LW650G/S/T/W-ZC 42LW659S-ZC

CAUTION

BEFORE SERVICING THE CHASSIS,
READ THE SAFETY PRECAUTIONS IN THIS MANUAL.

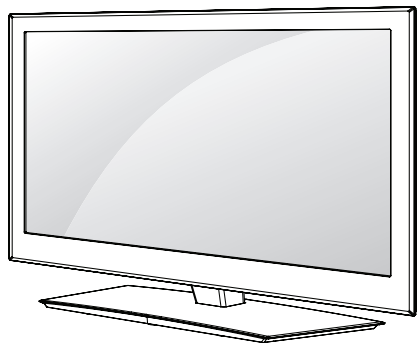

P/NO : MFL67002306 (1108-REV01)

Printed in Korea

CONTENTS

CONTENTS	2
PRODUCT SAFETY	3
SPECIFICATION	4
ADJUSTMENT INSTRUCTION	10
BLOCK DIAGRAM	19
EXPLODED VIEW	20
SCHEMATIC CIRCUIT DIAGRAM	

SAFETY PRECAUTIONS

IMPORTANT SAFETY NOTICE

Many electrical and mechanical parts in this chassis have special safety-related characteristics. These parts are identified by \triangle in the Schematic Diagram and Exploded View.

It is essential that these special safety parts should be replaced with the same components as recommended in this manual to prevent Shock, Fire, or other Hazards.

Do not modify the original design without permission of manufacturer.

General Guidance

An **isolation Transformer should always be used** during the servicing of a receiver whose chassis is not isolated from the AC power line. Use a transformer of adequate power rating as this protects the technician from accidents resulting in personal injury from electrical shocks.

It will also protect the receiver and its components from being damaged by accidental shorts of the circuitry that may be inadvertently introduced during the service operation.

If any fuse (or Fusible Resistor) in this TV receiver is blown, replace it with the specified.

When replacing a high wattage resistor (Oxide Metal Film Resistor, over 1 W), keep the resistor 10 mm away from PCB.

Keep wires away from high voltage or high temperature parts.

Before returning the receiver to the customer,

always perform an **AC leakage current check** on the exposed metallic parts of the cabinet, such as antennas, terminals, etc., to be sure the set is safe to operate without damage of electrical shock.

Leakage Current Cold Check(Antenna Cold Check)

With the instrument AC plug removed from AC source, connect an electrical jumper across the two AC plug prongs. Place the AC switch in the on position, connect one lead of ohm-meter to the AC plug prongs tied together and touch other ohm-meter lead in turn to each exposed metallic parts such as antenna terminals, phone jacks, etc.

If the exposed metallic part has a return path to the chassis, the measured resistance should be between 1 M Ω and 5.2 M Ω .

When the exposed metal has no return path to the chassis the reading must be infinite.

An other abnormality exists that must be corrected before the receiver is returned to the customer.

Leakage Current Hot Check (See below Figure)

Plug the AC cord directly into the AC outlet.

Do not use a line Isolation Transformer during this check.

Connect 1.5 K / 10 watt resistor in parallel with a 0.15 uF capacitor between a known good earth ground (Water Pipe, Conduit, etc.) and the exposed metallic parts.

Measure the AC voltage across the resistor using AC voltmeter with 1000 ohms/volt or more sensitivity.

Reverse plug the AC cord into the AC outlet and repeat AC voltage measurements for each exposed metallic part. Any voltage measured must not exceed 0.75 volt RMS which corresponds to 0.5 mA.

In case any measurement is out of the limits specified, there is possibility of shock hazard and the set must be checked and repaired before it is returned to the customer.

Leakage Current Hot Check circuit

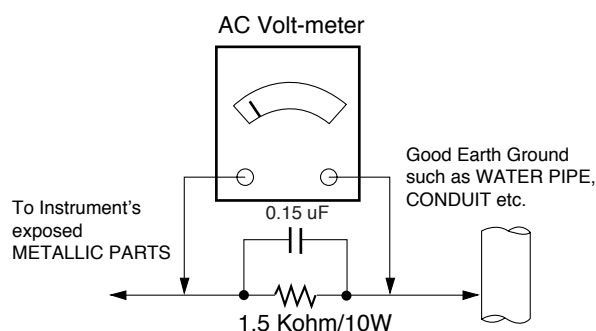

When 25A is impressed between Earth and 2nd Ground for 1 second, Resistance must be less than 0.1 Ω

*Base on Adjustment standard

SPECIFICATION

NOTE : Specifications and others are subject to change without notice for improvement.

1. Application range

This specification is applied to the LED LCD TV used LD12C chassis.

3. Test method

- 1) Performance: LGE TV test method followed
- 2) Demanded other specification
 - Safety : CE, IEC specification
 - EMC :CE, IEC

2. Requirement for Test

Each part is tested as below without special appointment.

- 1) Temperature: 25 °C ± 5 °C(77 °F ± 9 °F), CST: 40 °C ± 5 °C
- 2) Relative Humidity : 65 % ± 10 %
- 3) Power Voltage : Standard input voltage (AC 100-240 V~ 50 / 60 Hz)
 - * Standard Voltage of each products is marked by models.
- 4) Specification and performance of each parts are followed each drawing and specification by part number in accordance with BOM.
- 5) The receiver must be operated for about 5 minutes prior to the adjustment.

4. Model General Specification

No.	Item	Specification	Remarks
1	Market	EU(PAL Market-36Countries)	<p>DTV & Analog (Total 36 countries)</p> <p>DTV (MPEG2/4, DVB-T) : 31 countries (England/Italy/Germany/France/Spain/Sweden/Finland/Netherlands/Belgium/Luxemburg/Greece/Denmark/Czech/Austria/Hungary/Swiss/Croatia/Turkey/Norway/Slovenia/Poland/Ukraine/Portugal/Ireland/Morocco/Latvia/Estonia/Lithuania/Romania/Russia/Slovakia)</p> <p>DTV (MPEG2/4, DVB-T2): 5 countries (England/Denmark/Sweden/Finland/Norway)</p> <p>DTV (MPEG2/4, DVB-C): 10 countries Sweden/Finland/Austria/Swiss/Germany/Netherlands/Hungary/Slovenia/Norway/Denmark</p> <p>DTV (MPEG2/4,DVB-S): 31 countries Albania/Austria/Belgium/Bosnia/Bulgaria/Croatia/Czech/Estonia/France/Germany/Greece/Hungary/Ireland/Italy/Kazakhstan/Latvia/Lithuania/Luxembourg/Morocco/Netherlands/Poland/Portugal/Romania/Russia/Serbia/Slovenia/Spain/Slovakia/Switzerland/Turkey/Ukraine</p> <p>Analog Only - 5 countries (Bosnia/Serbia/Bulgaria/Albania/Kazakhstan)</p> <p>Supported satellite : 22 satellites HISPASAT 1C/1D, ATLANTIC BIRD 2, NILESAT 101/102, ATLANTIC BIRD 3, AMOS 2/3, THOR 5/6, IRIUS 4, EUTELSAT-W3A, EUROBIRD 9A, EUTELSAT-W2A, HOTBIRD 6/8/9, EUTELSAT-SESAT, ASTRA 1L/H/M/KR, ASTRA 3A/3B, BADR 4/6, ASTRA 2D, EUROBIRD 3, EUTELSAT-W7, HELLOSSAT 2, EXPRESS AM1, TURKSAT 2A/3A, INTERSAT10</p>
2	Broadcasting system	1) PAL-BG 2) PAL-DK 3) PAL-II' 4) SECAM L/L', DK, BG, I 5) DVB-T 6) DVB-C 7) DVB-T2 8) DVB-S	DVB-S :Satellite

No.	Item	Specification	Remarks
3	Receiving system	Analog : Upper Heterodyne Digital : COFDM , QAM	<p>► DVB-T</p> <ul style="list-style-type: none"> - Guard Interval(Bitrate_Mbit/s) 1/4, 1/8, 1/16, 1/32 - Modulation : Code Rate QPSK : 1/2, 2/3, 3/4, 5/6, 7/8 16-QAM : 1/2, 2/3, 3/4, 5/6, 7/8 64-QAM : 1/2, 2/3, 3/4, 5/6, 7/8 <p>► DVB-T2</p> <ul style="list-style-type: none"> - Guard Interval(Bitrate_Mbit/s) 1/4, 1/8, 1/16, 1/32, 1/128, 19/128, 19/256, - Modulation : Code Rate QPSK : 1/2, 2/5, 2/3, 3/4, 5/6 16-QAM : 1/2, 2/5, 2/3, 3/4, 5/6 64-QAM : 1/2, 2/5, 2/3, 3/4, 5/6 256-QAM : 1/2, 2/5, 2/3, 3/4, 5/6 <p>► DVB-C</p> <ul style="list-style-type: none"> - Symbolrate : 4.0Msymbols/s to 7.2Msymbols/s - Modulation : 16QAM, 64-QAM, 128-QAM and 256-QAM <p>► DVB-S</p> <ul style="list-style-type: none"> - Symbolrate DVB-S2 (8PSK/ QPSK) : 2 ~ 45 Msymbol/s DVB-S (QPSK) : 2~ 45 Msymbol/s -viterbi DVB-S mode : 1/2, 2/3, 3/4, 5/6, 7/8 DVB-S2 mode : 1/2, 2/3, 3/4, 3/5, 4/5, 5/6, 8/9, 9/10
4	Scart Gender Jack(1EA)	PAL, SECAM	Scart Jack is Full scart and support MNT/DTV-OUT, DTV Recording(not support DTV Auto AV)
5	Video Input RCA(2EA)	PAL, SECAM, NTSC	4System : PAL, SECAM, NTSC, PAL60 Rear 1EA, AV gender jack 1EA
6	Head phone out	Antenna, AV1, AV2, AV3, Component, RGB, HDMI1, HDMI2, HDMI3, HDMI4 USB	
7	Component Input(1EA)	Y/Cb/Cr, Y/Pb/Pr	Component Gender 1EA
8	RGB Input	RGB-PC	Analog(D-SUB 15PIN)
9	HDMI Input (4EA)	HDMI1-DTV/DVI HDMI2-DTV HDMI3-DTV HDMI4-DTV	PC(HDMI version 1.3) Support HDCP
10	Audio Input (4EA)	RGB/DVI Audio, Component, AV1, 2	L/R Input
11	SDPIF out (1EA)	SPDIF out	
12	USB (2EA)	EMF, DivX HD, For Service (download)	JPEG, MP3, DivX HD - USB current : max 500 mA - USB voltage : 4.75 V - 5.25 V
13	Wireless jack (1EA)	24V power & control	Voltage : 24 V, Power : max 8 W

5. Component Video Input (Y, Cb/Pb, Cr/Pr)

No.	Specification				Remark
	Resolution	H-freq(kHz)	V-freq(Hz)		
1.	720x480	15.73	60.00	SDTV,DVD 480i	
2.	720x480	15.63	59.94	SDTV,DVD 480i	
3.	720x480	31.47	59.94	480p	
4.	720x480	31.50	60.00	480p	
5.	720x576	15.625	50.00	SDTV,DVD 625 Line	
6.	720x576	31.25	50.00	HDTV 576p	
7.	1280x720	45.00	50.00	HDTV 720p	
8.	1280x720	44.96	59.94	HDTV 720p	
9.	1280x720	45.00	60.00	HDTV 720p	
10.	1920x1080	31.25	50.00	HDTV 1080i	
11.	1920x1080	33.75	60.00	HDTV 1080i	
12.	1920x1080	33.72	59.94	HDTV 1080i	
13.	1920x1080	56.250	50	HDTV 1080p	
14.	1920x1080	67.5	60	HDTV 1080p	

6. RGB (PC)

No.	Specification				Proposed	Remarks
	Resolution	H-freq(kHz)	V-freq(Hz)	Pixel Clock(MHz)		
1.	720*400	31.468	70.08	28.321		For only DOS mode
2.	640*480	31.469	59.94	25.17	VESA	Input 848*480 60 Hz, 852*480 60 Hz -> 640*480 60 Hz Display
3.	800*600	37.879	60.31	40.00	VESA	
4.	1024*768	48.363	60.00	65.00	VESA(XGA)	
5.	1360*768	47.72	59.8	84.75	WXGA	
6.	1920*1080	66.587	59.93	138.625	WUXGA	FHD model

7. HDMI Input

(1) DTV Mode

No.	Resolution	H-freq(kHz)	V-freq.(Hz)	Pixel clock(MHz)	Proposed	Remark
1.	720*480	31.469 /31.5	59.94 /60	27.00/27.03	SDTV 480P	
2.	720*576	31.25	50	54	SDTV 576P	
3.	1280*720	37.500	50	74.25	HDTV 720P	
4.	1280*720	44.96 /45	59.94 /60	74.17/74.25	HDTV 720P	
5.	1920*1080	33.72 /33.75	59.94 /60	74.17/74.25	HDTV 1080I	
6.	1920*1080	28.125	50.00	74.25	HDTV 1080I	
7.	1920*1080	26.97 /27	23.97 /24	74.17/74.25	HDTV 1080P	
8.	1920*1080	33.716 /33.75	29.976 /30.00	74.25	HDTV 1080P	
9.	1920*1080	56.250	50	148.5	HDTV 1080P	
10.	1920*1080	67.43 /67.5	59.94 /60	148.35/148.50	HDTV 1080P	

(2) PC Mode

No.	Resolution	H-freq(kHz)	V-freq.(Hz)	Pixel clock(MHz)	Proposed	Remark
1.	720*400	31.468	70.08	28.321		HDCP
2.	640*480	31.469	59.94	25.17	VESA	HDCP
3.	800*600	37.879	60.31	40.00	VESA	HDCP
4.	1024*768	48.363	60.00	65.00	VESA(XGA)	HDCP
5.	1360*768	47.72	59.8	84.75	WXGA	HDCP
6.	1280*1024	63.595	60.0	108.875	SXGA	HDCP/FHD model
7.	1920*1080	67.5	60.00	138.625	WUXGA	HDCP/FHD model

8. 3D Mode

(1) HDMI Input (1.4a)

No.	Resolution	H-freq(kHz)	V-freq.(Hz)	Pixel clock(MHz)	Proposed	3D input proposed mode
1	1920*1080	53.95 / 54	23.98 / 24	148.35/148.5	HDTV 1080P	Frame packing
2	1280*720	89.9 / 90	59.94/60	148.35/148.5	HDTV 720P	Frame packing
3	1280*720	75	50	148.5	HDTV 720P	Frame packing
4	1920*1080	67.5	60	148.5	HDTV 1080P	Side by Side(half), Top and bottom
5	1920*1080	56.3	50	148.5	HDTV 1080P	Side by Side(half), Top and bottom
6	1280*720	45	60	74.25	HDTV 720P	Side by Side(half), Top and Bottom
7	1280*720	37.5	50	74.25	HDTV 720P	Side by Side(half), Top and Bottom
8	1920*1080	33.7	60	74.25	HDTV 1080i	Side by Side(half), Top and Bottom
9	1920*1080	28.1	50	74.25	HDTV 1080i	Side by Side(half), Top and Bottom
10	1920*1080	27	24	74.25	HDTV 1080P	Side by Side(half), Top and Bottom
11	1920*1080	33.7	30	89.1	HDTV 1080P	Side by Side(half), Top and Bottom

(2) HDMI Input (1.3)

No.	Resolution	H-freq(kHz)	V-freq.(Hz)	Pixel clock(MHz)	Proposed	3D input proposed mode
1	1280*720	45.00	60.00	74.25	HDTV 720P	Side by Side, Top & Bottom
2	1280*720	37.500	50	74.25	HDTV 720P	Side by Side, Top & Bottom
3	1920*1080	33.75	60.00	74.25	HDTV 1080I	Side by Side, Top & Bottom
4	1920*1080	28.125	50.00	74.25	HDTV 1080I	Side by Side, Top & Bottom
5	1920*1080	27.00	24.00	74.25	HDTV 1080P	Side by Side, Top & Bottom, Checkerboard
6	1920*1080	33.75	30.00	74.25	HDTV 1080P	Side by Side, Top & Bottom, Checkerboard
7	1920*1080	67.50	60.00	148.5	HDTV 1080P	Side by Side, Top & Bottom, Checkerboard, Single Frame Sequential
8	1920*1080	56.250	50	148.5	HDTV 1080P	Side by Side, Top & Bottom, Checkerboard, Single Frame Sequential

(3) RF 3D Input(DTV)

No.	Resolution	H-freq(kHz)	V-freq.(Hz)	Pixel clock(MHz)	Proposed	3D input proposed mode
1	1280*720	37.500	50	74.25	HDTV 720P	Side by Side, Top & Bottom
2	1920*1080	28.125	50	74.25	HDTV 1080I	Side by Side, Top & Bottom

(4) USB Input

No.	Resolution	H-freq(kHz)	V-freq.(Hz)	Pixel clock(MHz)	3D input proposed mode	Proposed
1	1920*1080	33.75	30.000	74.25	Side by Side Top & Bottom Checkerboard	HDTV 1080P



(5) RGB-PC Input

No.	Resolution	H-freq(kHz)	V-freq.(Hz)	Pixel clock(MHz)	Proposed	3D input proposed mode
1	1920*1080	67.5	60	148.5	HDTV 1080P	Side by Side, Top & Bottom

(6) DLNA

No.	Resolution	H-freq(kHz)	V-freq.(Hz)	Pixel clock(MHz)	Proposed	3D input proposed mode
1	1920*1080	33.75	30		HDTV 1080P	Side by Side, Top & Bottom, Checkerboard

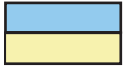
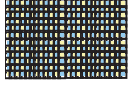
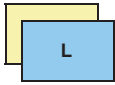
(7) 3D Input mode

No.	Side by Side	Top & Bottom	Checkerboard	Single Frame Sequential	Frame Packing
1.					

ADJUSTMENT INSTRUCTION

1. Application Range

This specification sheet is applied to all of the LED LCD TV with LD12C chassis.

2. Designation

- (1) Because this is not a hot chassis, it is not necessary to use an isolation transformer. However, the use of isolation transformer will help protect test instrument.
- (2) Adjustment must be done in the correct order.
- (3) The adjustment must be performed in the circumstance of $25\text{ }^{\circ}\text{C} \pm 5\text{ }^{\circ}\text{C}$ of temperature and $65\% \pm 10\%$ of relative humidity if there is no specific designation.
- (4) The input voltage of the receiver must keep AC 100-240V ~ 50 / 60Hz.
- (5) The receiver must be operated for about 5 minutes prior to the adjustment when module is in the circumstance of over 15.

In case of keeping module is in the circumstance of 0 °C, it should be placed in the circumstance of above 15 °C for 2 hours

In case of keeping module is in the circumstance of below -20 °C, it should be placed in the circumstance of above 15 °C for 3 hours.

[Caution]

When still image is displayed for a period of 20 minutes or longer (especially where W/B scale is strong. Digital pattern 13ch and/or Cross hatch pattern 09ch), there can be some afterimage in the black level area.

3. Automatic Adjustment

3.1. ADC Adjustment

- (1) Overview
ADC adjustment is needed to find the optimum black level and gain in Analog-to-Digital device and to compensate RGB deviation.
* If Adjust ADC is "OTP", It doesn't need ADC adjustment. (GP3-BCM)

- (2) Equipment & Condition
 - 1) Jig (RS-232C protocol)
 - 2) MSPG-925 Series Pattern Generator(MSPG-925FA, pattern - 65)
 - Resolution : 480i Comp1
1080P Comp1
1920*1080 RGB
 - Pattern : Horizontal 100% Color Bar Pattern
 - Pattern level : 0.7 ± 0.1 Vp-p
 - Image

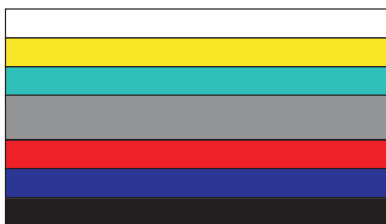

(3) Adjustment

1) Adjustment method

- Using RS-232, adjust items in the other shown in "3.1.(3).3"

2) Adj. protocol

Protocol	Command	Set ACK
Enter adj. mode	aa 00 00	a 00 OK00x
Source change	xb 00 40	b 00 OK40x (Adjust 480i, 1080p Comp1)
	xb 00 60	b 00 OK60x (Adjust 1920*1080 RGB)
Begin adj.	ad 00 10	
Return adj. result		OKx (Case of Success) NGx (Case of Fail)
Read adj. data	(main) ad 00 20	(main) 0000000000000000000000000000000007c007b006dx
	(sub) ad 00 21	(Sub) 00000007000000000000000000000007c00830077x
Confirm adj.	ad 00 99	NG 03 00x (Fail)
		NG 03 01x (Fail)
		NG 03 02x (Fail)
		OK 03 03x (Success)
End adj.	aa 00 90	a 00 OK90x

Ref.) ADC Adj. RS232C Protocol_Ver1.0

3) Adj. order

- aa 00 00 [Enter ADC adj. mode]
- xb 00 04 [Change input source to Component1(480i&1080p)]
- ad 00 10 [Adjust 480i Comp1]
- xb 00 06 [Change input source to RGB(1024*768)]
- ad 00 10 [Adjust 1024*768 RGB]
- ad 00 90 End adj.

3.2. MAC Address

(1) Equipment & Condition

- Play file: Serial.exe
- MAC Address edit
- Input Start / End MAC address

(2) Download method

1) Communication Prot connection

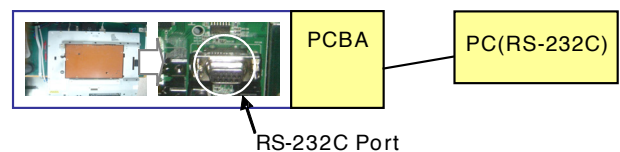

Connect: PCBA Jig-> RS-232C Port== PC-> RS-232C Port

- 2) MAC Address Download
 - Com 1,2,3,4 and 115200(Baud rate)
 - Port connection button click(1)

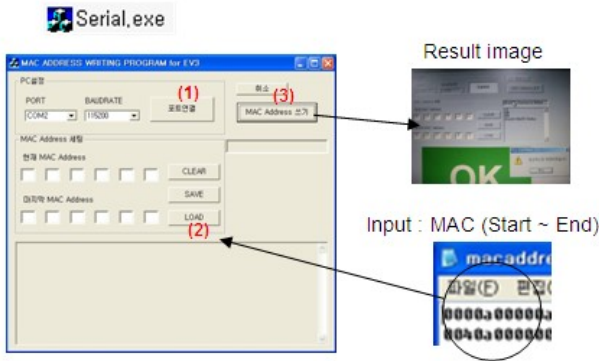

- Load button click(2) for MAC Address write.
- Start MAC Address write button(3)
- Check the OK Or NG

3.3. LAN Inspection

- (1) Equipment & Condition
 - Each other connection to LAN Port of IP Hub and Jig

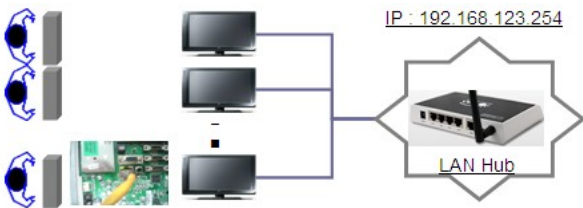

- (2) LAN inspection solution
 - LAN Port connection with PCBA
 - Network setting at MENU Mode of TV
 - setting automatic IP
 - Setting state confirmation
 - > If automatic setting is finished, you confirm IP and MAC Address.

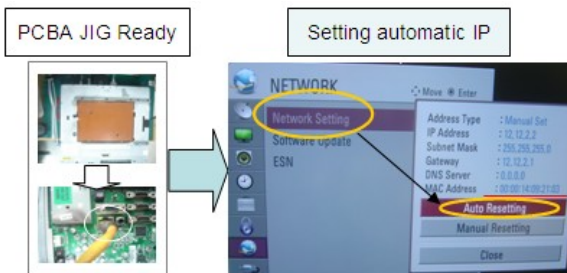

3.4. LAN PORT INSPECTION(PING TEST)

Connect SET -> LAN port == PC -> LAN Port



- (1) Equipment setting
 - 1) Play the LAN Port Test PROGRAM.
 - 2) Input IP set up for an inspection to Test Program.
*IP Number : 12.12.2.2
- (2) LAN PORT inspection (PING TEST)
 - 1) Play the LAN Port Test Program.
 - 2) Connect each other LAN Port Jack.
 - 3) Play Test (F9) button and confirm OK Message.
 - 4) Remove LAN CABLE

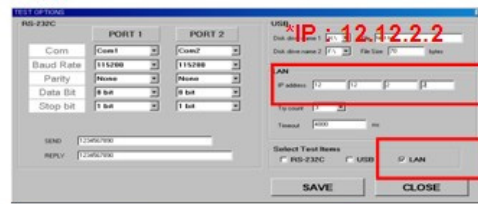

3.5. Model name & Serial number Download

- (1) Model name & Serial number D/L
 - Press "Power on" key of service remote control.(Baud rate : 115200 bps)
 - Connect RS232 Signal Cable to RS-232 Jack.
 - Write Serial number by use RS-232.
 - Must check the serial number at Instart menu.

- (2) Method & notice
 - A. Serial number D/L is using of scan equipment.
 - B. Setting of scan equipment operated by Manufacturing Technology Group.
 - C. Serial number D/L must be conformed when it is produced in production line, because serial number D/L is mandatory by D-book 4.0

* Manual Download (Model Name and Serial Number)
 If the TV set is downloaded by OTA or service man, sometimes model name or serial number is initialized.(Not always)

There is impossible to download by bar code scan, so It need Manual download.

- Press the 'instart' key of ADJ remote control.
- Go to the menu '5.Model Number D/L' like below photo.
- Input the Factory model name(ex 42LW950-ZA) or Serial number like photo.

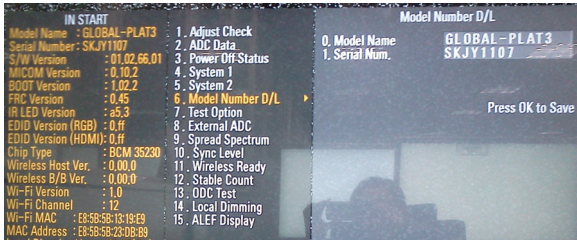

- Check the model name Instart menu -> Factory name displayed (ex 42LW750S-ZA)
- Check the Diagnostics (DTV country only) -> Buyer model displayed (ex 42LW750S-ZA)

3.6. CI+ Key Download method

3.6.1. Download Procedure

- Press "Power on" key of a Service Remote control. (Baud rate : 115200 bps)
- Connect RS232-C Signal Cable.
- Write CI+ Key through RS-232-C.
- Check whether the key was downloaded or not at 'In Start' menu. (Refer to below).



=> Check the Download to CI+ Key value in LGset.

3.6.2. Check the method of CI+ Key value

- check the method on Instart menu
- check the method of RS232C Command
 - into the main ass'y mode (RS232 : aa 00 00)

CMD 1	CMD 2	Data 0	
A	A	0	0

- check the key download for transmitted command (RS232 : ci 00 10)

CMD 1	CMD 2	Data 0	
C	I	1	0

- result value
 - normally status for download : OKx
 - abnormally status for download : NGx

3.6.3. Check the method of CI+ Key value (RS232)

- into the main ass'y mode (RS232 : aa 00 00)

CMD 1	CMD 2	Data 0	
A	A	0	0

- Check the method of CI+ key by command (RS232 : ci 00 20)

CMD 1	CMD 2	Data 0	
C	I	2	0

- Result value

i 01 OK 1d1852d21c1ed5dcx
 ↳ CI+ key Value

3.7. Widevine Key Download method

3.7.1. Widevine key Download

- Press "Power on" key of a Service Remote control (Baud rate : 115200 bps)
- Connect RS232-C Signal Cable.
- Write Widevine Key through RS-232-C.
- Check whether the key was downloaded or not at 'In Start' menu. (Refer to below).

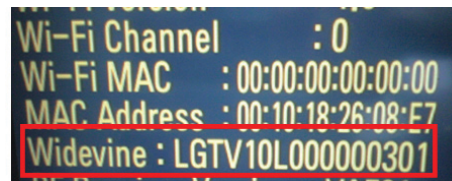

=> Check the Download to Widevine Key value in LGset.

3.7.2. check the method of Widevine Key value.

- Check the method on Instart menu.
- Check the method of RS232C Command.
 - into the main ass'y mode (RS232 : aa 00 00)

CMD 1	CMD 2	Data 0	
A	A	0	0

- Check the key download for transmitted command (RS232 : ci 00 10)

CMD 1	CMD 2	Data 0	
C	I	1	0

- result value

- normally status for download : OKx
 - abnormally status for download : NGx
 -

3.7.3 check the method of Widevine Key value (RS232)

- into the main ass'y mode (RS232 : aa 00 00)

CMD 1	CMD 2	Data 0	
A	A	0	0

- Check the method of Widevine key by command (RS232 : ci 00 20)

CMD 1	CMD 2	Data 0	
C	I	2	0

- result value

i 01 OK 1d1852d21c1ed5dcx
 ↳ Widevine key Value

3.8. Mac+Widevine+GP3 BCM CI+ download

3.8.1 Connect: PCBA Jig-> RS-232C Port== PC-> RS-232C Port

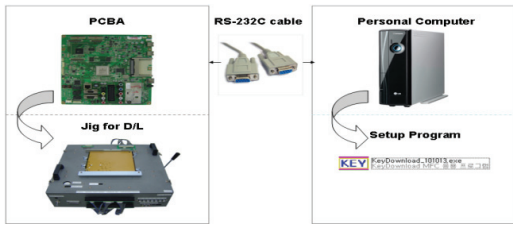

3.8.2 MAC Address, CI Plus key and Widevine Key write.
11Y LCD TV + MAC + Widevine + GP3_BCM CI Plus

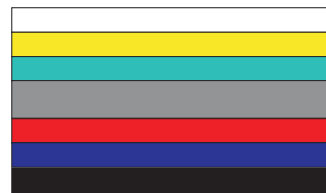
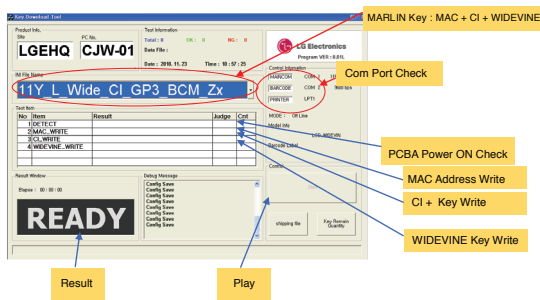

(3) Must use standard cable

- (1) Equipment setting
 - Play file: keydownload.exe
 - select the download items.(MARLIN)
- (2) Communication Prot connection
 - Key Write :Com 1,2,3,4 and 115200(Baudrate)
 - Barcode : Com 1,2,3,4 and 9600(Baudrate)
- (3) Mode check: Online Only
- (4) Check the test process: DETECT -> MAC -> CI -> WIDEVINE
- (5) Play: START
- (6) Result: Ready, Test, OK or NG

3.9. LNB voltage and 22KHz tone check

- only for DVB-S/S2 model

- (1) Test method
 - 1) Press "Power on" key of a service Remote control. (Baud rate : 115200 bps)
 - 2) Connect cable between satellite ANT and test JIG.
 - 3). Connect RS232-C Signal Cable.
 - 4) Write LNB ON control command through RS-232-C.
 - 5) check LED light 'ON' at 18V menu.
 - 6) check LED light 'ON' at 22KHz tone menu.
 - 7) Write LNB OFF control command through RS-232-C.
 - 8) check LED light 'OFF' at 18V menu.
 - 9) check LED light 'OFF' at 22KHz tone menu.

(2) RS-232 command for test LNB

	Command	Set ACK
LNB On	[A][I][][Set ID][][30][Cr]	[O][K][x] or NG : [N][G][x]
LNB Off	[A][I][][Set ID][][40][Cr]	[O][K][x] or NG : [N][G][x]

- (3) Test result
 - After send LNB On command, '18V LED' and '22KHz tone LED' should be ON.
 - After send LNB OFF command, '18V LED' and '22KHz tone LED' should be OFF.

4. Manual Adjustment

4.1. ADC(GP3) Adjustment

4.1.1. Overview

ADC adjustment is needed to find the optimum black level and gain in Analog-to-Digital device and to compensate RGB deviation.

4.1.2. Equipment & Condition

- (1) Adjust Remote control
- (2) 801GF(802B, 802F, 802R) or MSPG925FA Pattern Generator
 - Resolution : 480i, 720*480(MSPG-925FA->Model:209, Pattern:65)-480i 1080p, 1920*1080(MSPG-925FA->Model:225, Pattern:65)-1080p
 - Pattern : Horizontal 100 % Color Bar Pattern
 - Pattern level: 0.7 ± 0.1 Vp-p
 - Image

4.1.3. Adjust method

* If Adjust ADC is "OTP", It doesn't need ADC adjustment. (GP3-BM)

- (1) ADC 480i, 1080p Comp1
 - 1) Check connected condition of Component 1 cable to the equipment.
 - 2) Give a 480i, 1080p Mode, Horizontal 100% Color Bar Pattern to Component 1. (MSPG-925FA -> Model: 209, Pattern: 65) - 480i (MSPG-925FA -> Model: 225, Pattern: 65) - 1080p
 - 3) Change input mode as Component 1 and picture mode as "Standard"
 - 4) Press the In-start Key on the ADJ remote after at least 1 min of signal reception. Then, select 7. External ADC -> 1. COMP 1080p on the menu. Press enter key. The adjustment will start automatically.
 - 5) If ADC calibration is successful, "ADC RGB Success" is displayed. If ADC calibration is failure, "ADC RGB Fail" is displayed.
 - 6) If ADC calibration is failure, after recheck ADC pattern or condition retry calibration Error message refer to 5).
- (2) ADC 1920*1080 RGB
 - 1) Check connected condition of Component & RGB cable to the equipment
 - 2) Give a 1920*1080 Mode, 100 % Horizontal Color Bar Pattern to RGB port. (MSPG-925 Series -> model: 225 , pattern: 65)
 - 3) Change input mode as RGB and picture mode as "Standard".
 - 4) Press the In-start Key on the ADJ remote after at least 1 min of signal reception. Then, select 7. External ADC -> 1. COMP 1080p on the menu. Press enter key. The adjustment will start automatically.
 - 5) If ADC calibration is successful, "ADC RGB Success" is displayed. If ADC calibration is failure, "ADC RGB Fail" is displayed.
 - 6) If ADC calibration is failure, after recheck ADC pattern or condition retry calibration Error message refer to 5).

4.2. EDID(The Extended Display Identification Data)/DDC(Display Data Channel) download

(1) Overview



It is a VESA regulation. A PC or a MNT will display an optimal resolution through information sharing without any necessity of user input. It is a realization of "Plug and Play".

(2) Equipment

- Adjust remote control
- Since embedded EDID data is used, EDID download JIG, HDMI cable and D-sub cable are not need.

(3) Download method

- 1) Press Adj. key on the Adj. R/C, then select "10.EDID D/L", By pressing Enter key, enter EDID D/L menu.
- 2) Select [Start] key by pressing Enter key, HDMI1/ HDMI2/ HDMI3/ RGB are Writing and display OK or NG.

For Analog EDID	For HDMI EDID	
D-sub to D-sub	DVI-D to HDMI or HDMI to HDMI	
		

(4) EDID DATA_3D

■ HDMI

	0x00	0x01	0x02	0x03	0x04	0x05	0x06	0x07	0x08	0x09	0x0A	0x0B	0x0C	0x0D	0x0E	0x0F
0x00	0	FF	FF	FF	FF	FF	FF	0	1E	6D						
0x01			1	3	80	10	9	78	0A	EE	91	A3	54	4C	99	26
0x02	0F	50	54	A1	8	0	71	40	81	C0	81	0	81	80	95	0
0x03	90	40	A9	C0	B3	0	2	3A	80	18	71	38	2D	40	58	2C
0x04	45	0	A0	5A	0	0	0	1E	66	21	50	B0	51	0	1B	30
0x05	40	70	36	0	A0	5A	0	0	0	1E	0	0	0	FD	0	39
0x06	3F	1F	52	10	0	0A	20	20	20	20	20	20				
0x07															1	1
0x00	2	3	37	F1	4E	10	1F	84	13	5	14	3	2	12	20	21
0x01	22	15	1	26	15	7	50	9	57	7						
0x02																
0x03				E3	5	3	1	1	1D	80	18	71	1C	16	20	58
0x04	2C	25	0	A0	5A	0	0	0	9E	1	1D	0	80	51	D0	1A
0x05	20	6E	88	55	0	A0	5A	0	0	0	1A	2	3A	80	18	71
0x06	38	2D	40	58	2C	45	0	A0	5A	0	0	0	1E	0	0	0
0x07	0	0	0	0	0	0	0	0	0	0	0	0	0	0	0	2

■ RGB

	0x00	0x01	0x02	0x03	0x04	0x05	0x06	0x07	0x08	0x09	0x0A	0x0B	0x0C	0x0D	0x0E	0x0F
0x00	0	FF	FF	FF	FF	FF	FF	0	1E	6D						
0x01			1	3	68	10	9	78	0A	EE	91	A3	54	4C	99	26
0x02	0F	50	54	A1	8	0	71	40	81	C0	81	0	81	80	95	0
0x03	90	40	A9	C0	B3	0	2	3A	80	18	71	38	2D	40	58	2C
0x04	45	0	A0	5A	0	0	0	1E	66	21	50	B0	51	0	1B	30
0x05	40	70	36	0	A0	5A	0	0	0	1E	0	0	0	FD	0	3A
0x06	3E	1E	53	10	0	0A	20	20	20	20	20	20				
0x07															0	3

(5) EDID DATA_2D

■ HDMI

	0x00	0x01	0x02	0x03	0x04	0x05	0x06	0x07	0x08	0x09	0x0A	0x0B	0x0C	0x0D	0x0E	0x0F
0x00	0	FF	FF	FF	FF	FF	FF	0	1E	6D						
0x01			1	3	80	10	9	78	0A	EE	91	A3	54	4C	99	26
0x02	0F	50	54	A1	8	0	71	40	81	C0	81	0	81	80	95	0
0x03	90	40	A9	C0	B3	0	2	3A	80	18	71	38	2D	40	58	2C
0x04	45	0	A0	5A	0	0	0	1E	66	21	50	B0	51	0	1B	30
0x05	40	70	36	0	A0	5A	0	0	0	1E	0	0	0	FD	0	39
0x06	3F	1F	52	10	0	0A	20	20	20	20	20	20				
0x07															1	1
0x00	2	3	26	F1	4E	10	1F	84	13	5	14	3	2	12	20	21
0x01	22	15	1	26	15	7	50	9	57	7	67					
0x02				E3	5	3	1	1	1D	80	18	71	1C	16	20	58
0x03	25	0	A0	5A	0	0	0	9E	1	1D	0	80	51	D0	1A	20
0x04	6E	88	55	0	A0	5A	0	0	0	1A	2	3A	80	18	71	38
0x05	2D	40	58	2C	45	0	A0	5A	0	0	0	1E	66	21	50	B0
0x06	51	0	1B	30	40	70	36	0	A0	5A	0	0	0	1E	0	0
0x07	0	0	0	0	0	0	0	0	0	0	0	0	0	0	0	2

■ RGB

	0x00	0x01	0x02	0x03	0x04	0x05	0x06	0x07	0x08	0x09	0x0A	0x0B	0x0C	0x0D	0x0E	0x0F
0x00	0	FF	FF	FF	FF	FF	FF	0	1E	6D						
0x01			1	3	68	10	9	78	0A	EE	91	A3	54	4C	99	26
0x02	0F	50	54	A1	8	0	71	40	81	C0	81	0	81	80	95	0
0x03	90	40	A9	C0	B3	0	2	3A	80	18	71	38	2D	40	58	2C
0x04	45	0	A0	5A	0	0	0	1E	66	21	50	B0	51	0	1B	30
0x05	40	70	36	0	A0	5A	0	0	0	1E	0	0	0	FD	0	3A
0x06	3E	1E	53	10	0	0A	20	20	20	20	20	20				
0x07															0	3

■ Reference

- HDMI1 ~ HDMI4 / RGB

- In the data of EDID, bellows may be different by S/W or Input mode.

Product ID

Model Name	HEX	EDID Table	DDC Function
ALL	0001	0100	Analog
	0001	0100	Digital

Serial No. : Controlled on product line

Month, Year: Controlled on production line:

ex) Monthly : '01' -> '01'

Year : '2010' -> '14'

Model Name(Hex):

MODEL	MODEL NAME(HEX)
all	00 00 00 FC 00 4C 47 20 54 56 0A 20 20 20 20 20 20 20

Checksum: Changeable by total EDID data._3D

INPUT	1	2	3
HDMI1	7F	CB	X
HDMI2	7F	BB	X
HDMI3	7F	AB	X
HDMI4	7F	9B	X
RGB	X	X	98

Checksum: Changeable by total EDID data._2D

INPUT	1	2	3
HDMI1	7F	D9	X
HDMI2	7F	C9	X
HDMI3	7F	B9	X
HDMI4	7F	A9	X
RGB	X	X	98

Vendor Specific(HDMI)_3D

INPUT	MODEL NAME(HEX)
HDMI1	78 03 0C 00 10 00 B8 2D 20 C0 0E 01 40 0A 3C 08 10 18 10 98 10 58 10 38 10
HDMI2	78 03 0C 00 20 00 B8 2D 20 C0 0E 01 40 0A 3C 08 10 18 10 98 10 58 10 38 10
HDMI3	78 03 0C 00 30 00 B8 2D 20 C0 0E 01 40 0A 3C 08 10 18 10 98 10 58 10 38 10
HDMI4	78 03 0C 00 40 00 B8 2D 20 C0 0E 01 40 0A 3C 08 10 18 10 98 10 58 10 38 10

Vendor Specific(HDMI)_2D

INPUT	MODEL NAME(HEX)
HDMI1	67 03 0C 00 10 00 B8 2D
HDMI2	67 03 0C 00 20 00 B8 2D
HDMI3	67 03 0C 00 30 00 B8 2D
HDMI4	67 03 0C 00 40 00 B8 2D

4.3. White Balance Adjustment

4.3.1 Overview

- W/B adj. Objective & How-it-works
- Objective: To reduce each Panel's W/B deviation
- How-it-works : When R/G/B gain in the OSD is at 192, it means the panel is at its Full Dynamic Range. In order to prevent saturation of Full Dynamic range and data, one of R/G/B is fixed at 192, and the other two is lowered to find the desired value.
- Adj. condition : normal temperature
 - Surrounding Temperature : 25 °C ± 5 °C
 - Warm-up time: About 5 Min
 - Surrounding Humidity : 20 % ~ 80 %

* Before White balance adjustment, Keep power on status. don't power off.

* ALEF Header(Module with T-con) supplied as SKD has White Balance data. (White balance data is stored in EEPROM of the T-con Board)
It doesn't need to adjust White balance if "3. Adjust White Balance" is OK as figure below.

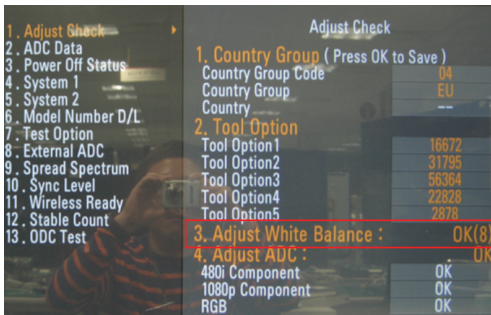

4.3.2 Equipment

- Color Analyzer: CA-210 (LED Module : CH 14)
- Adj. Computer(During auto adj., RS-232C protocol is needed)
- Adjust Remote control
- Video Signal Generator MSPG-925F 720p/216-Gray (Model:204, Pattern:80IRE)
-> Only when internal pattern is not available

■ Color Analyzer Matrix should be calibrated using CS-1000

4.3.3. Equipment connection MAP

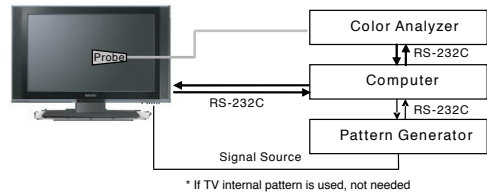

* If TV internal pattern is used, not needed

4.3.4. Adj. Command (Protocol)

<Command Format>

[START] [6E] [A] [50] [A] [LEN] [A] [03] [A] [CMD] [A] [00] [A] [VAL] [A] [CS] [A] [STOP]

- LEN: Number of Data Byte to be sent
 - CMD: Command
 - VAL: FOS Data value
 - CS: Checksum of sent data
 - A: Acknowledge
- Ex) [Send: JA_00_DD] / [Ack: A_00_okDDX]

■ RS-232C Command used during auto-adj.

RS-232C COMMAND			Explanation
[CMD]	ID	DATA]	
wb	00	00	Begin White Balance adj.
wb	00	10	Gain adj.(internal white pattern)
wb	00	1f	Gain adj. completed
wb	00	20	Offset adj.(internal white pattern)
wb	00	2f	Offset adj. completed
wb	00	ff	End White Balance adj.(Internal pattern disappears)

- Ex) wb 00 00 -> Begin white balance auto-adj.
 wb 00 10 -> Gain adj.
 ja 00 ff -> Adj. data
 jb 00 c0
 ...
 ...
 wb 00 1f -> Gain adj. completed
 *(wb 00 20(Start), wb 00 2f(completed)) -> Off-set adj.
 wb 00 ff -> End white balance auto-adj.

■ Adj. Map

	ITEM	Command		Data Range(Hex.)		Default(Decimal)
		Cmd 1	Cmd 2	Min	Max	
Cool	R-Gain	j	g	00	C0	
	G-Gain	j	h	00	C0	
	B-Gain	j	i	00	C0	
	R-Cut					
	G-Cut					
	B-Cut					
Medium	R-Gain	j	a	00	C0	
	G-Gain	j	b	00	C0	
	B-Gain	j	c	00	C0	
	R-Cut					
	G-Cut					
	B-Cut					
Warm	R-Gain	j	d	00	C0	
	G-Gain	j	e	00	C0	
	B-Gain	j	f	00	C0	
	R-Cut					
	G-Cut					
	B-Cut					

4.3.5. Adjustment method

(1) Auto adjustment method

- 1) Set TV in adj. mode using POWER ON key.
- 2) Zero calibrate probe then place it on the center of the Display.
- 3) Connect Cable (RS-232C)
- 4) Select mode in adj. Program and begin adjustment.
- 5) When adjustment is complete (OK Sign), check adjustment status pre mode. (Warm, Medium, Cool)
- 6) Remove probe and RS-232C cable to complete adj.

■ W/B Adj. must begin as start command “wb 00 00”, and finish as end command “wb 00 ff”, and Adj. offset if need.

(2) Manual adjustment method

- 1) Set TV in Adjustment mode using POWER ON
- 2) Zero Calibrate the probe of Color Analyzer, then place it on the center of LCD module within 10 cm of the surface.
- 3) Press ADJ key -> EZ adjust using adjustment R/C -> 7. White-Balance then press the cursor to the right key(▶). (When key(▶) is pressed 216 Gray internal pattern will be displayed)
- 4) One of R Gain / G Gain / B Gain should be fixed at 192, and the rest will be lowered to meet the desired value.
- 5) Adj. is performed in COOL, MEDIUM, WARM 3 modes of color temperature.

■ If internal pattern is not available, use RF input. In EZ Adj. menu 7.White Balance, you can select one of 2 Test-pattern: ON, OFF. Default is inner(ON). By selecting OFF, you can adjust using RF signal in 216 Gray pattern.

■ Adj. condition and cautionary items

- 1) Lighting condition in surrounding area
Surrounding lighting should be lower 10 lux. Try to isolate adj. area into dark surrounding.
- 2) Probe location : Color Analyzer(CA-210) probe should be within 10 cm and perpendicular of the module surface (80° ~ 100°)
- 3) Aging time
 - After Aging Start, Keep the Power ON status during 5 Minutes.
 - In case of LCD, Back-light on should be checked using no signal or Full-white pattern.

4.3.6. Reference(White Balance Adj. coordinate and temperature)

■ Luminance : 204 Gray

■ Standard color coordinate and temperature using CS-1000 (over 26 inch)

Mode	Color Coordination		Temp	ΔUV
	x	y		
COOL	0.269	0.273	13000 K	0.0000
MEDIUM	0.285	0.293	9300 K	0.0000
WARM	0.313	0.329	6500 K	0.0000

■ Standard color coordinate and temperature using CA-210 (CH 14)

Mode	Color Coordination		Temp	ΔUV
	x	y		
COOL	0.269 ± 0.002	0.273 ± 0.002	13000 K	0.0000
MEDIUM	0.285 ± 0.002	0.293 ± 0.002	9300 K	0.0000
WARM	0.313 ± 0.002	0.329 ± 0.002	6500 K	0.0000

4.3.7. White balance table

■ Module change color coordinate because of aging time.

■ Apply under the color coordinate table, for compensated aging time.

GP2	Aging Time (Min.)	Cool		Medium		Warm	
		X	Y	X	Y	X	Y
		269	273	285	293	313	329
1	0-2	279	288	295	308	319	338
2	3-5	278	286	294	306	318	336
3	6-9	277	285	293	305	317	335
4	10-19	276	283	292	303	316	333
5	20-35	274	280	290	300	314	330
6	36-49	272	277	288	297	312	327
7	50-79	271	275	287	295	311	325
8	80-149	270	274	286	294	310	324
9	Over 150	269	273	285	293	309	323

4.4. Wireless function check

Step 1) Connect set and Dongle of Wireless to Cable of HDMI & TTA 20Pin

Step 2) At OSD of SET, check the message like Fig.3

Step 3) Detach Cable of Wireless Dongle



Fig.1
<Dongle>



Connect



Fig.2
<Wireless Ready Set>

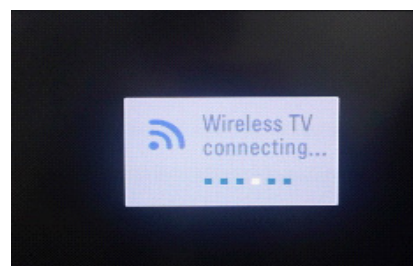

Fig.3 Connect the Dongle
(Dongle Connection Display)

4.5. EYE-Q function check

- Step 1) Turn on TV
- Step 2) Press EYE key of Adj. R/C
- Step 3) Cover the Eye Q II sensor on the front of the using your hand and wait for 6 seconds
- Step 4) Confirm that R/G/B value is lower than 10 of the "Raw Data (Sensor data, Back light)". If after 6 seconds, R/G/B value is not lower than 10, replace Eye Q II sensor.
- Step 5) Remove your hand from the Eye Q II sensor and wait for 6 seconds.
- Step 6) Confirm that "ok" pop up. If change is not seen, replace Eye Q II sensor.



4.6. Local Dimming Function Check

- (1) Turn on TV.
- (2) At the Local Dimming mode, module Edge Backlight moving Top to Bottom Back light of IOP module moving.
- (3) Confirm the Local Dimming mode.
- (4) Press "exit" key

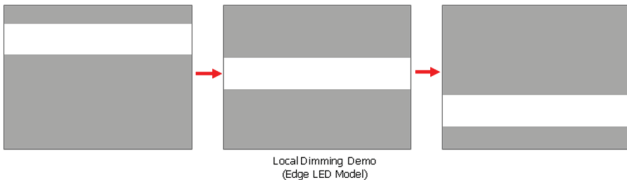

Local Dimming Demo (Edge LED Model)

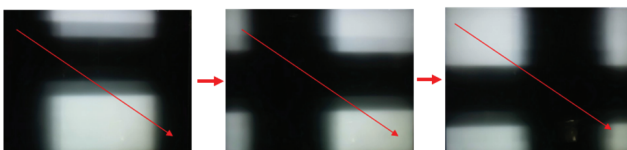

Local Dimming Demo (IOP&ALEF Model)

4.7. Magic Motion Remote control test

- Equipment : RF Remote control for test, IR-KEY-Code Remote control for test
- You must confirm the battery power of RF-Remote control before test.(recommend that change the battery per every lot)
- Sequence (test)
 - 1) if you select the 'start key(Mute)' on the controller, you can pairing with the TV SET.
 - 2) You can check the cursor on the TV Screen, when select the 'OK' key on the controller.
 - 3) You must remove the pairing with the TV Set by select 'Vol+(STOP)' key on the controller.

4.8. 3D function test

- (Pattern Generator MSHG-600, MSPG-6100 [Support HDMI 1.4])
 * HDMI mode No. 872, pattern No. 83)
- 1) Please input 3D test pattern like below



- 2) When 3D OSD appear automatically, then select OK key.



- 3) Don't wear a 3D Glasses, Check the picture like below.



4.9. LNB voltage and 22 KHz tone check

(only for DVB-S/S2 model)

- (1) Test method

- 1) Set TV in Adj. mode using POWER ON.
- 2) Connect cable between satellite ANT and test JIG.
- 3) Press Yellow key (ETC+SWAP) in Adj Remote control to make LNB on.
- 4) check LED light 'ON' at 18V menu.
- 5) check LED light 'ON' at 22KHz tone menu.
- 6) Press Blue key (ETC+PIP INPUT) in Adj Remote control to make LNB off.
- 7) Check LED light 'OFF' at 18 V menu.
- 8) Check LED light 'OFF' at 22 KHz tone menu.

- (2) Test result

- After press LNB On key, '18 V LED' and '22 KHz tone LED' should be ON.
- After press LNB OFF key, '18 V LED' and '22 KHz tone LED' should be OFF.

4.10. Option selection per country

(1) Overview

- Option selection is only done for models in Non-EU.
- Applied model: LD03D/03E Chassis applied EU model.

(2) Method

- 1) Press ADJ key on the Adj. Remote Control, then select Country Group Menu.
- 2) Depending on destination, select Country Group Code 04 or Country Group EU then on the lower Country option, select US, CA, MX. Selection is done using +, - or ►◀ KEY.

4.11. Tool Option selection

- Method : Press Adj. key on the Adj. Remote Control, then select Tool option.

4.12. Ship-out mode check(In-stop)

- After final inspection, press IN-STOP key of the Adj. R/C and check that the unit goes to Stand-by mode.

5. GND and Internal Pressure check

5.1. Method

- 1) GND & Internal Pressure auto-check preparation
 - Check that Power Cord is fully inserted to the SET. (If loose, re-insert)
- 2) Perform GND & Internal Pressure auto-check
 - Unit fully inserted Power cord, Antenna cable and A/V arrive to the auto-check process.
 - Connect D-terminal to AV JACK TESTER
 - Auto CONTROLLER(GWS103-4) ON
 - Perform GND TEST
 - If NG, Buzzer will sound to inform the operator.
 - If OK, changeover to I/P check automatically. (Remove CORD, A/V form AV JACK BOX)
 - Perform I/P test
 - If NG, Buzzer will sound to inform the operator.
 - If OK, Good lamp will lit up and the stopper will allow the pallet to move on to next process.

5.2. Checkpoint

- TEST voltage
 - GND: 1.5 KV/min at 100 mA
 - SIGNAL: 3 KV/min at 100 mA
- TEST time: 1 second
- TEST POINT
 - GND TEST = POWER CORD GND & SIGNAL CABLE METAL GND
 - Internal Pressure TEST = POWER CORD GND & LIVE & NEUTRAL
- LEAKAGE CURRENT: At 0.5 mArms

6. Audio

No.	Item	Min.	Typ.	Max.	Unit	
1.	Audio practical max Output, L/R (Distortion=10 % max Output)	9	10	12	W	EQ Off AVL Off
			0.5		Vrms	Clear Voice Off
2.	Speaker (8 Ω Impedance)	9	10.0	12.0	W	EQ On AVL On Clear Voice On

Measurement condition:

1. RF input: Mono, 1 KHz sine wave signal, 100 % Modulation
2. CVBS, Component: 1 KHz sine wave signal 0.4 Vrms
3. RGB PC: 1 KHz sine wave signal 0.7 Vrms

7. USB S/W Download (option, Service only)

- 1) Put the USB Stick to the USB socket.
- 2) Automatically detecting update file in USB Stick.
 - If your downloaded program version in USB Stick is Low, it didn't work. But your downloaded version is High, USB data is automatically detecting.
- 3) Show the message "Copying files from memory".

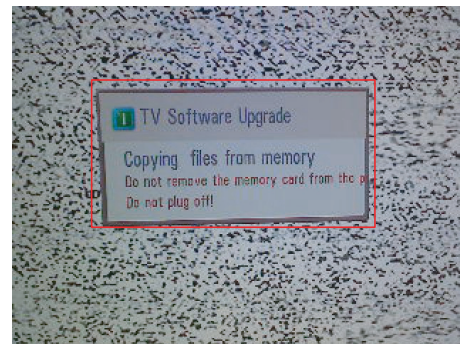

- 4) Updating is starting.

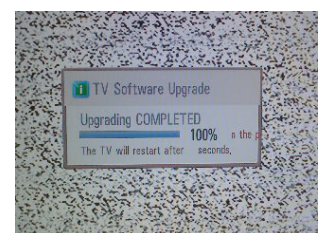
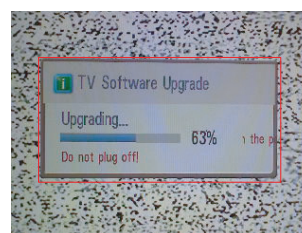

- 5) Updating Completed, The TV will restart automatically
- 6) If your TV is turned on, check your updated version and Tool option. (explain the Tool option, next stage)
 - * If downloading version is more high than your TV have, TV can lost all channel data. In this case, you have to channel recover. if all channel data is cleared, you didn't have a DTV/ATV test on production line.

* After downloading, have to adjust TOOL OPTION again.

- 1) Push "IN-START" key in service remote control.
- 2) Select "Tool Option 1" and push "OK" key.
- 3) Push in the number. (Each model has their number.)

BLOCK DIAGRAM

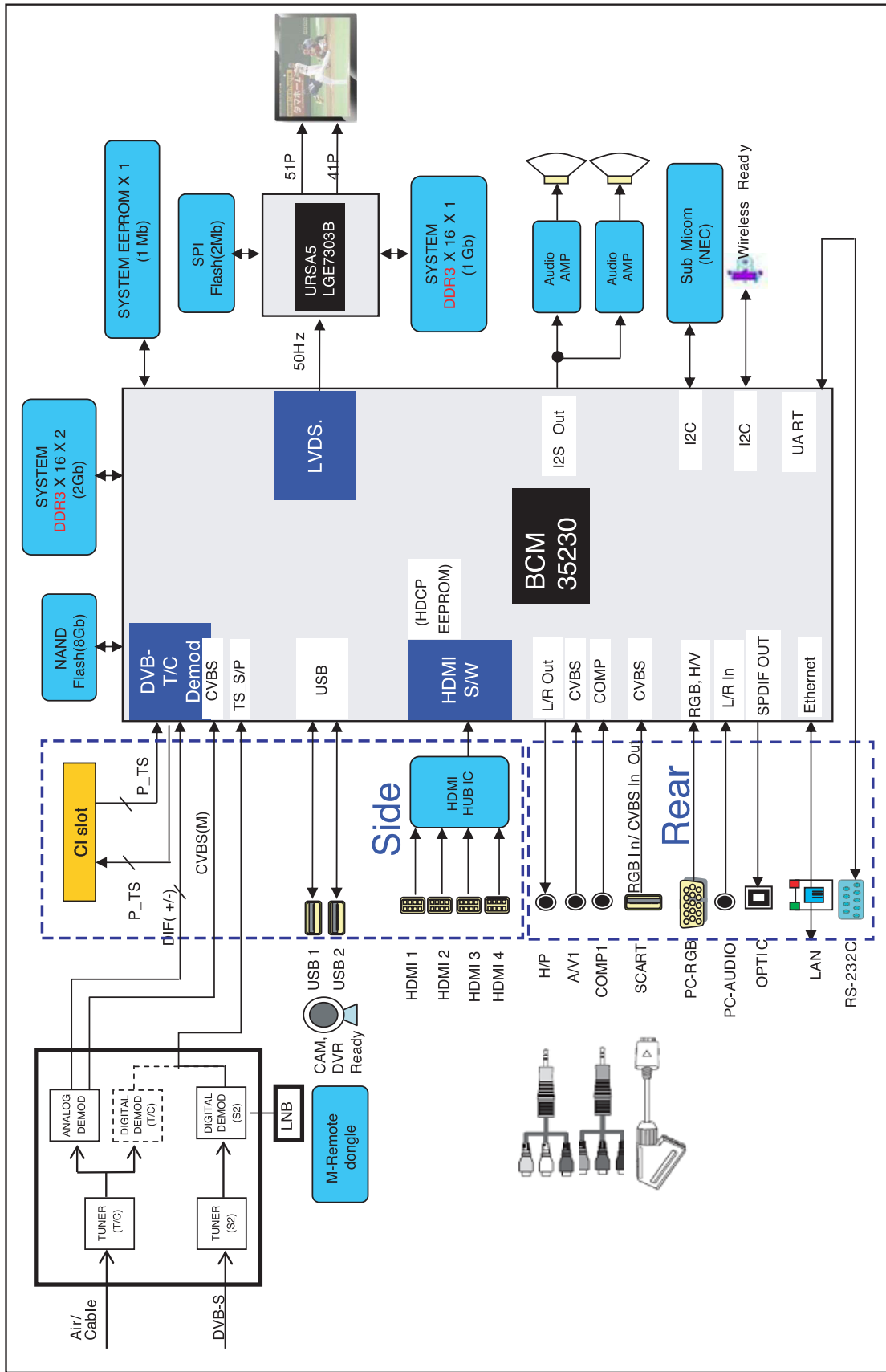

EXPLODED VIEW

IMPORTANT SAFETY NOTICE

Many electrical and mechanical parts in this chassis have special safety-related characteristics. These parts are identified by  in the Schematic Diagram and EXPLODED VIEW. It is essential that these special safety parts should be replaced with the same components as recommended in this manual to prevent X-RADIATION, Shock, Fire, or other Hazards. Do not modify the original design without permission of manufacturer.

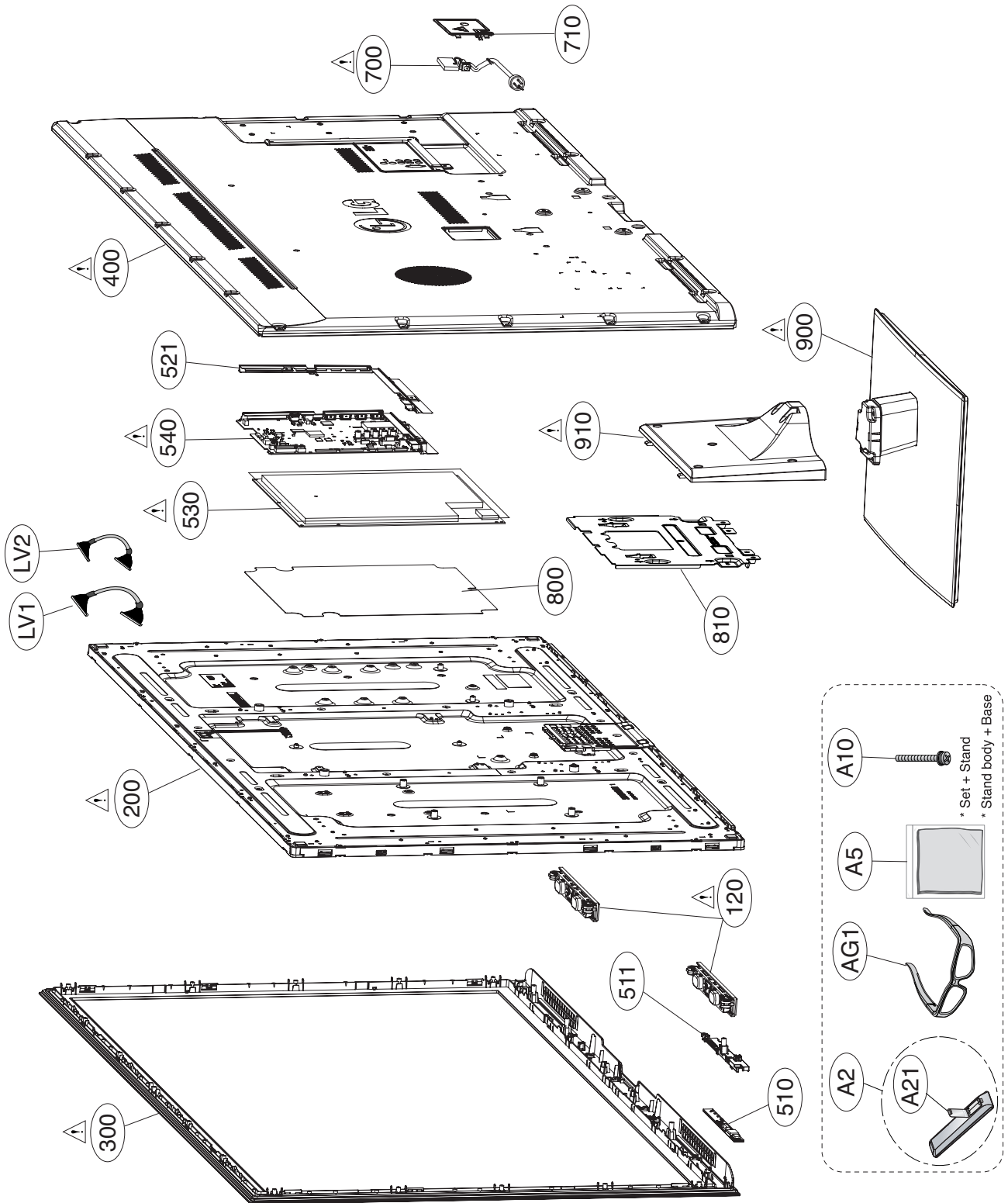

NAND FLASH MEMORY 8Gbit

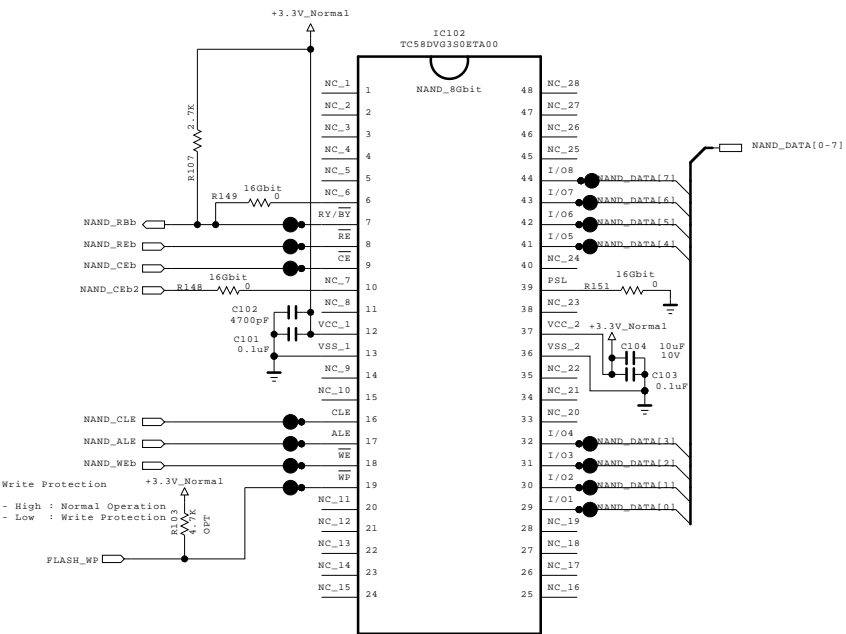

16Gbit

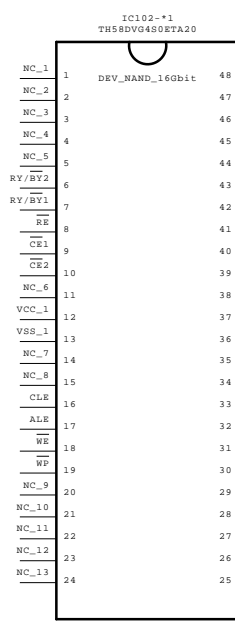

Boot ROM Device Select - (FA4, FAD7, FAD2, FAD1)

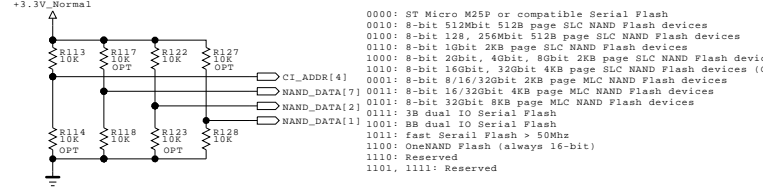

NAND ECC (FA3, FA2, FALE)

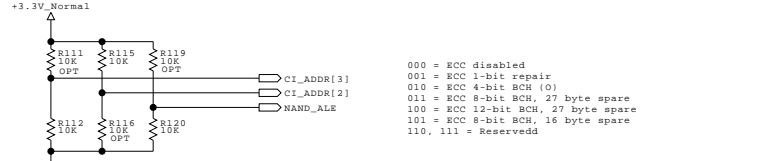

DUAL COMPONENT

IC102	1ST : EAN61000101 2ND : T-TH58DVG4S0ETA20
IC102-*1	

Strap Setting

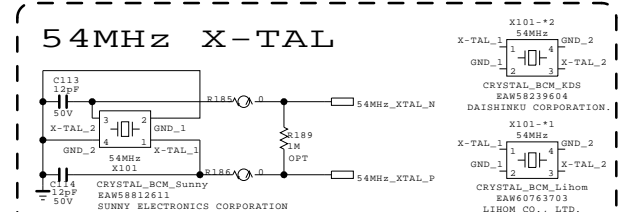
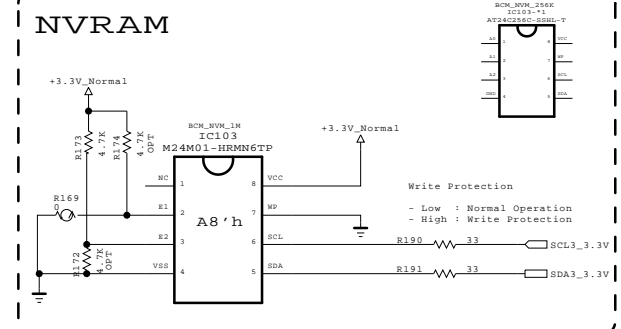
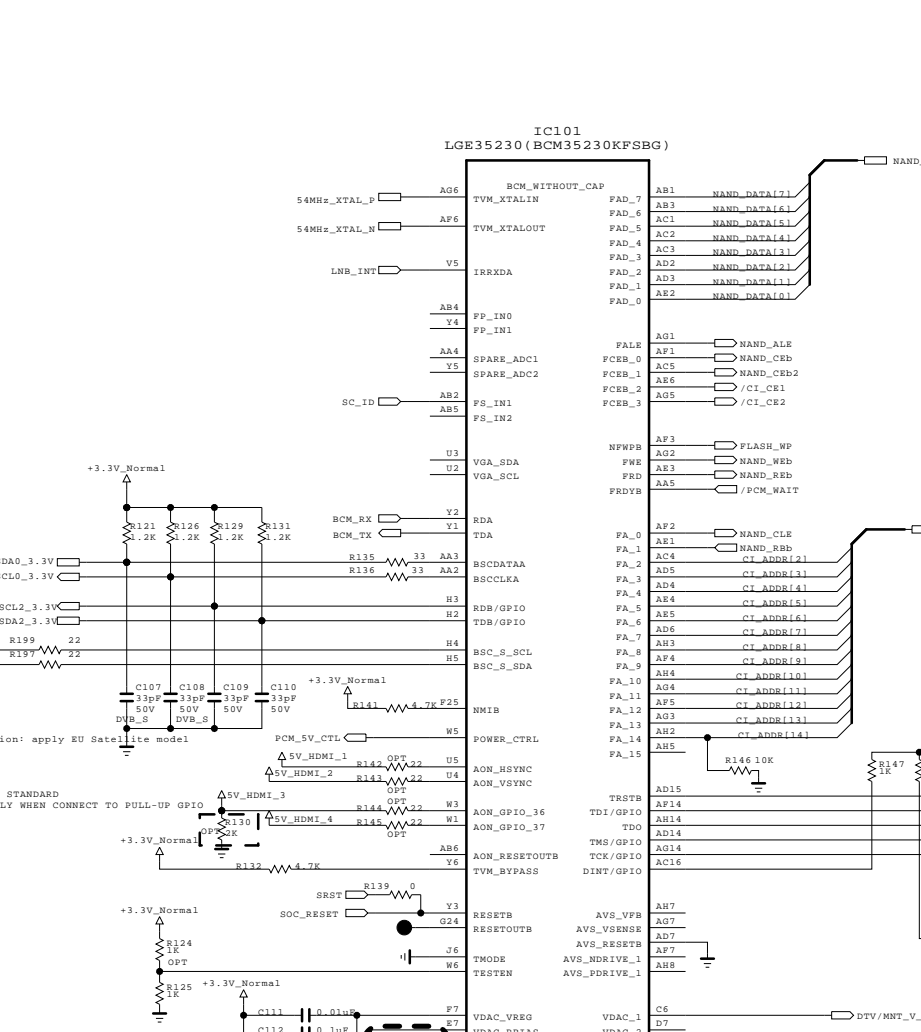
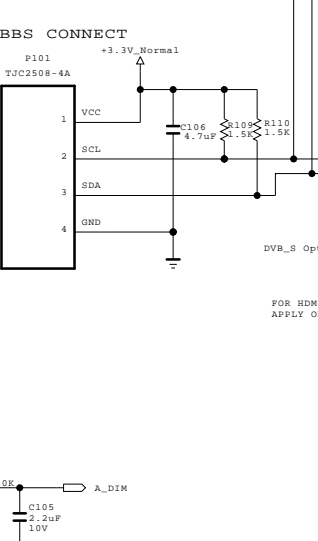
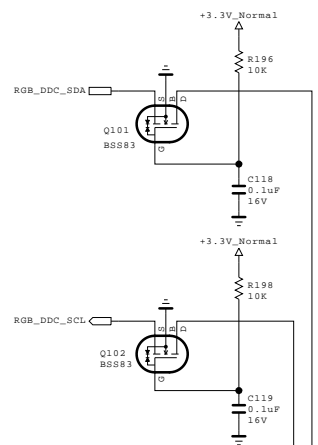
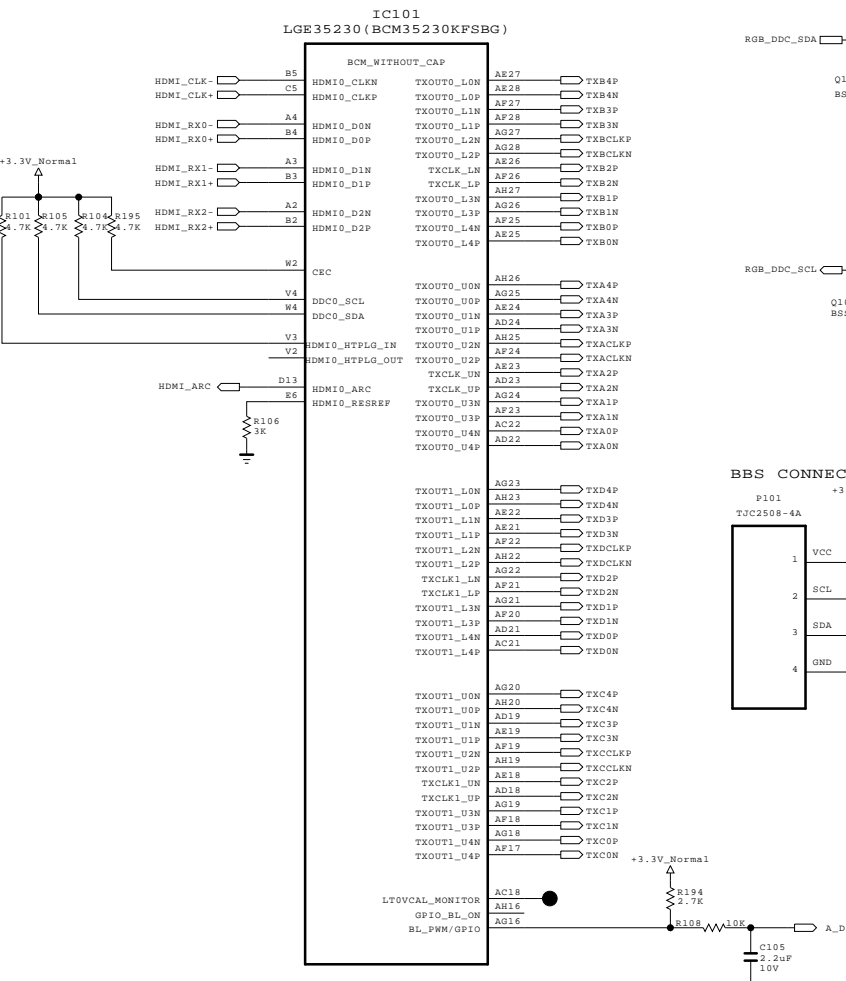
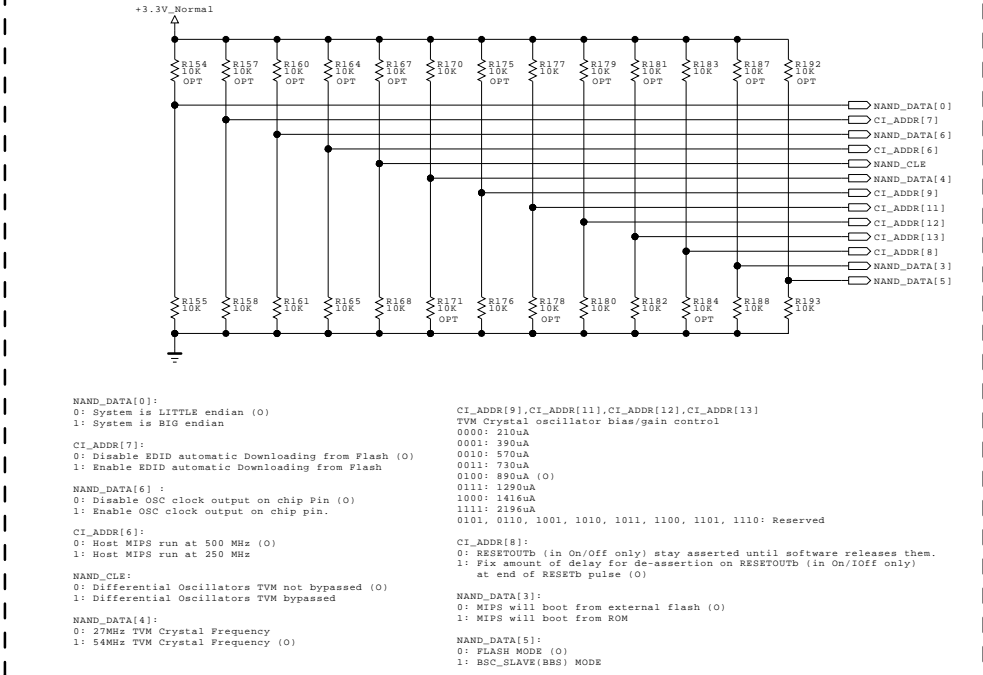

THE Δ SYMBOL MARK OF THIS SCHEMATIC DIAGRAM INCORPORATES SPECIAL FEATURES IMPORTANT FOR PROTECTION FROM X-RADIATION. FILRE AND ELECTRICAL SHOCK HAZARDS, WHEN SERVICING IF IS ESSENTIAL THAT ONLY MANUFACTURERS SPECIFIED PARTS BE USED FOR THE CRITICAL COMPONENTS IN THE Δ SYMBOL MARK OF THE SCHEMATIC.

SECRET
LGElectronics



MODEL	BCM35230	DATE	2010.09.18
BLOCK	MAIN & NAND FLASH	SHEET	01

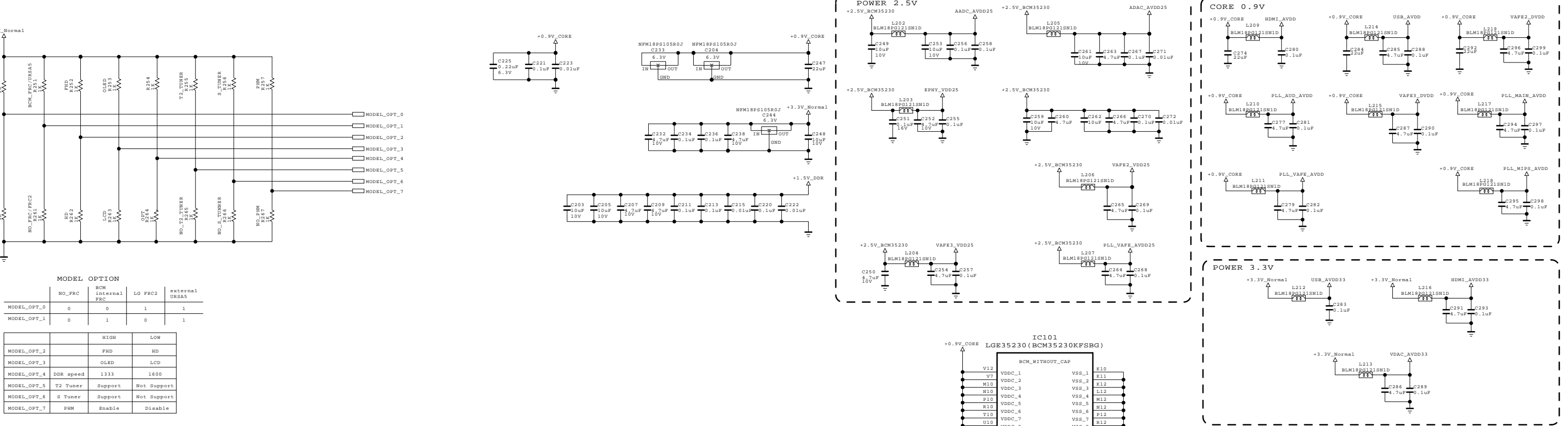

MODEL OPTION			
MODEL_OPTION	NO_FRG	RCW Internal FRG	external URSA5
MODEL_OPT_0	0	0	1
MODEL_OPT_1	0	1	1

	HIGH	LOW	
MODEL_OPT_2	FWD	HD	
MODEL_OPT_3	OLRD	LCD	
MODEL_OPT_4	DDR speed	1333	1600
MODEL_OPT_5	T2 Tuner	Support	Not Support
MODEL_OPT_6	S Tuner	Support	Not Support
MODEL_OPT_7	PHM	Enable	Disable

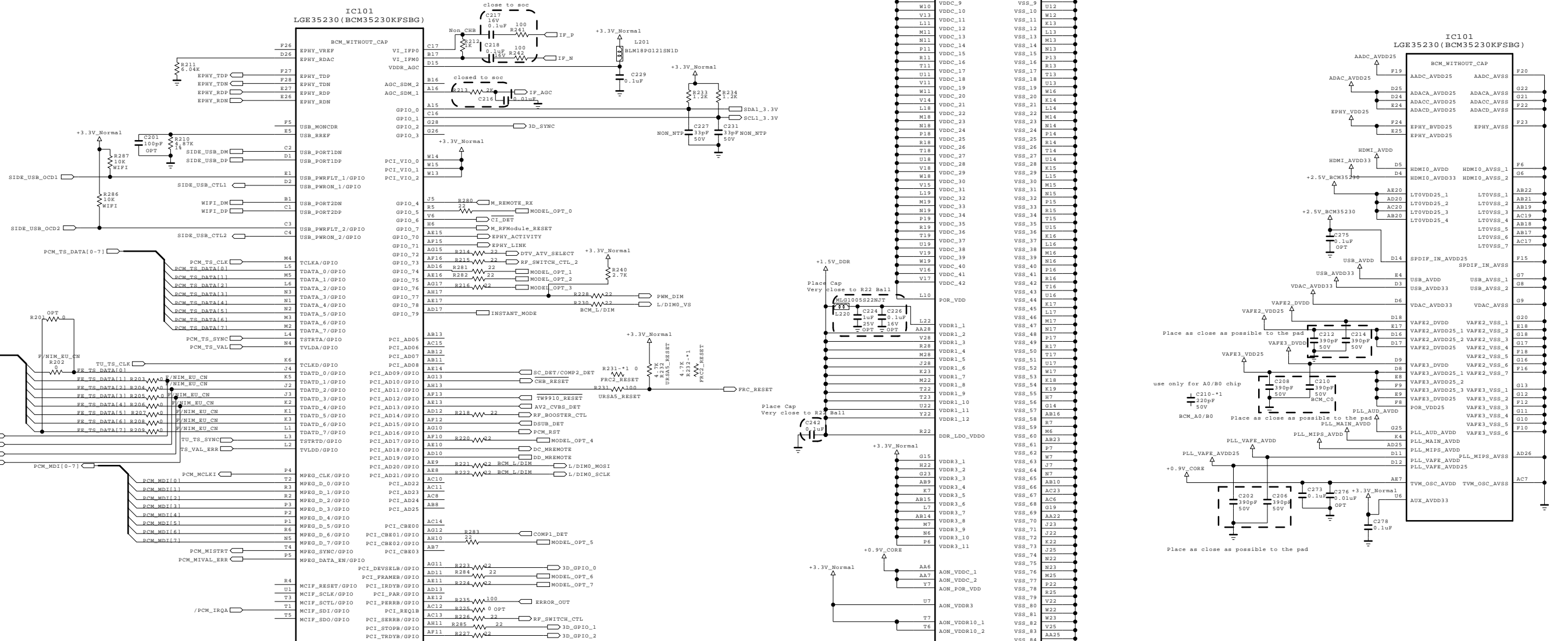

THE ⚠ SYMBOL MARK OF THIS SCHEMATIC DIAGRAM INCORPORATES SPECIAL FEATURES IMPORTANT FOR PROTECTION FROM X-RADIATION. FILRE AND ELECTRICAL SHOCK HAZARDS, WHEN SERVICING IF IS ESSENTIAL THAT ONLY MANUFACTURERS SPECIFIED PARTS BE USED FOR THE CRITICAL COMPONENTS IN THE ⚠ SYMBOL MARK OF THE SCHEMATIC.

SECRET
LG Electronics

LG ELECTRONICS

MODEL	BCM35230	DATE	
BLOCK	MAIN POWER	SHEET	02

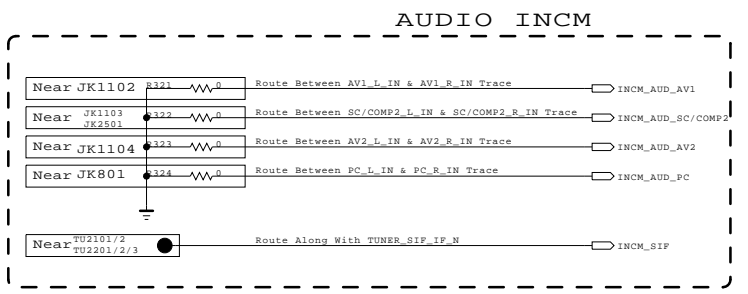
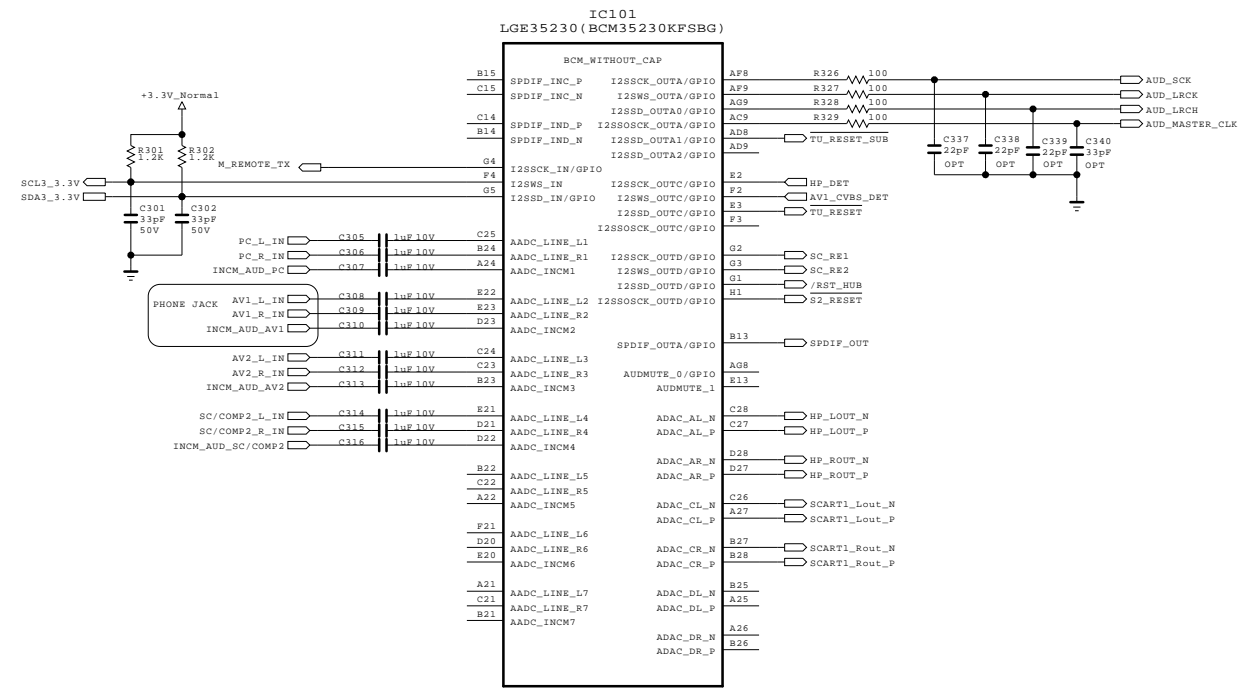
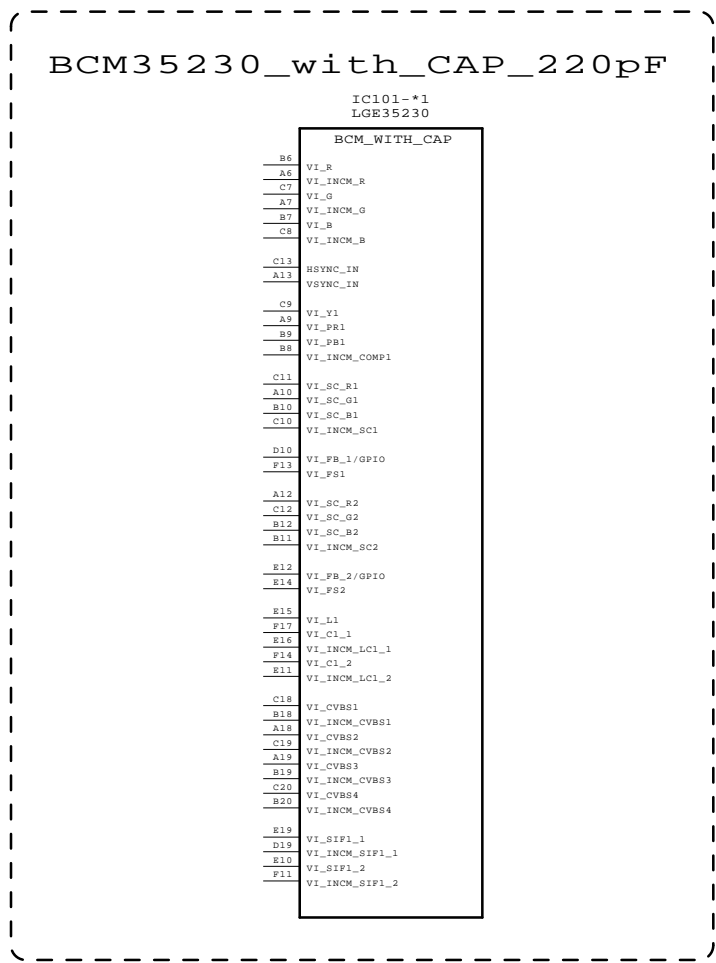
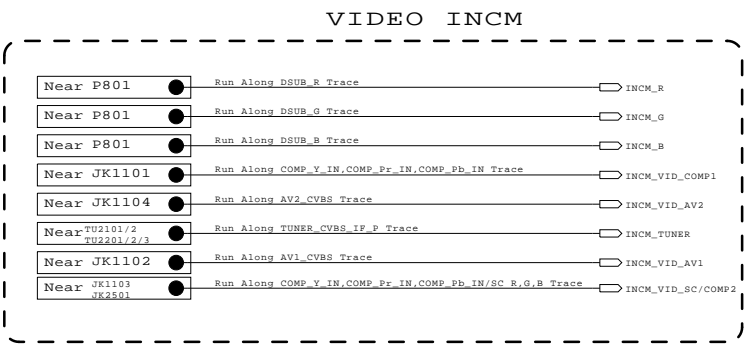
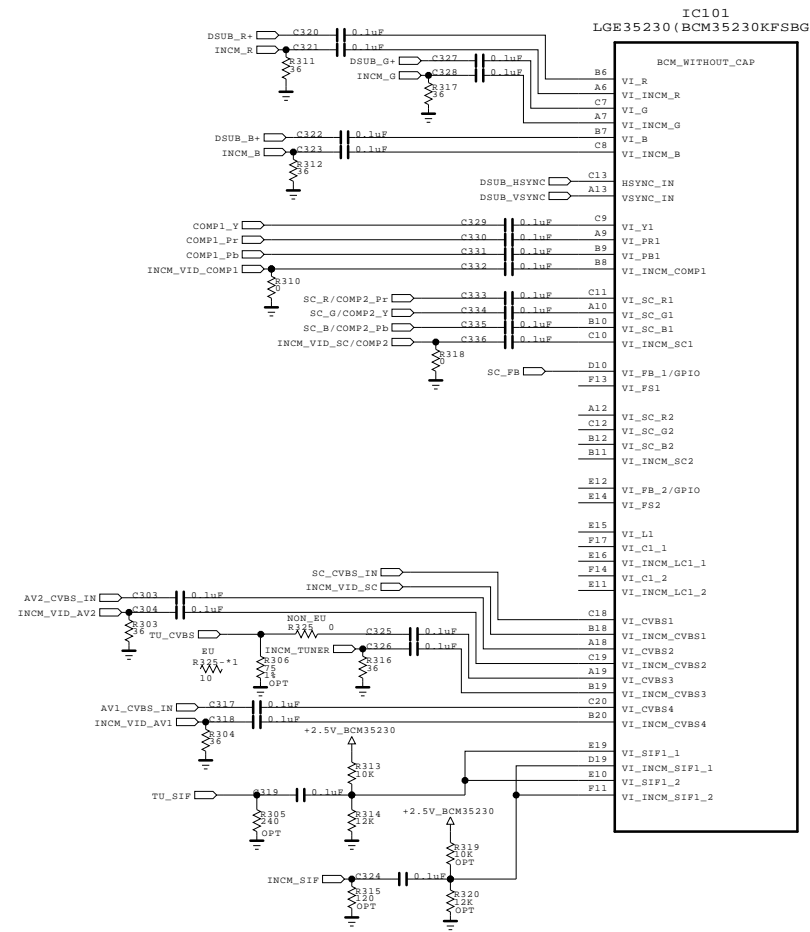

THE SYMBOL MARK OF THIS SCHEMATIC DIAGRAM INCORPORATES SPECIAL FEATURES IMPORTANT FOR PROTECTION FROM X-RADIATION. FILRE AND ELECTRICAL SHOCK HAZARDS, WHEN SERVICING IF IS ESSENTIAL THAT ONLY MANUFACTURES SPECIFIED PARTS BE USED FOR THE CRITICAL COMPONENTS IN THE SYMBOL MARK OF THE SCHEMATIC.

SECRET
LGElectronics



MODEL	BCM35230	DATE	
BLOCK	MAIN AUDIO/VIDEO	SHEET	03

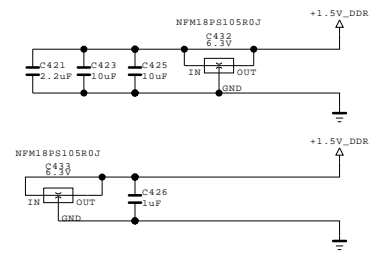
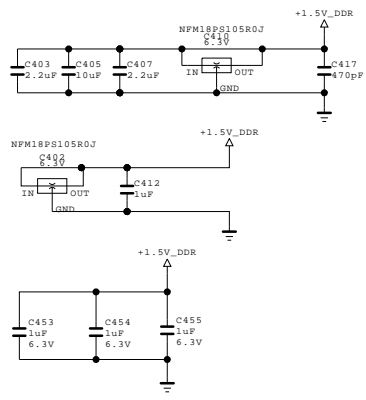
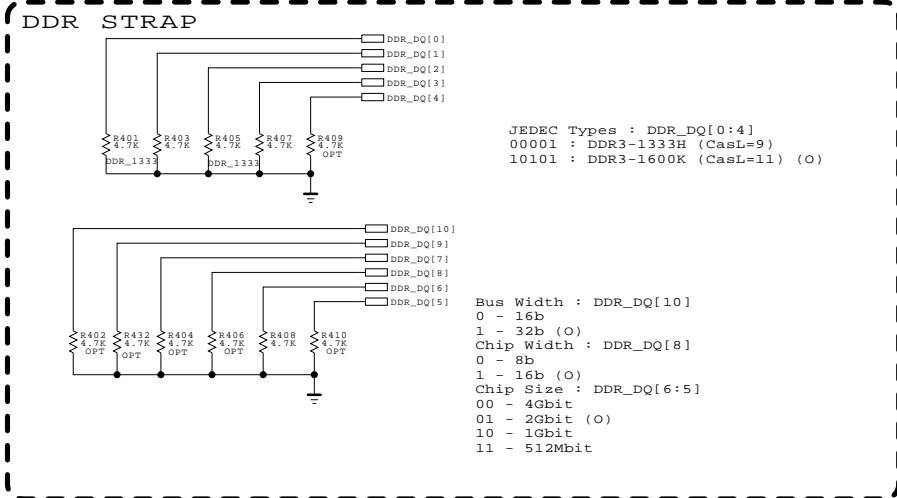

DUAL COMPONENT	
IC401,IC402	1ST : EAN61667501, 2ND : EAN61570701
IC401-*1 IC402-*1	1ST : T-K4B2G1646B_HCK0, 2ND : T-H5TQ2G63BFR-PBC

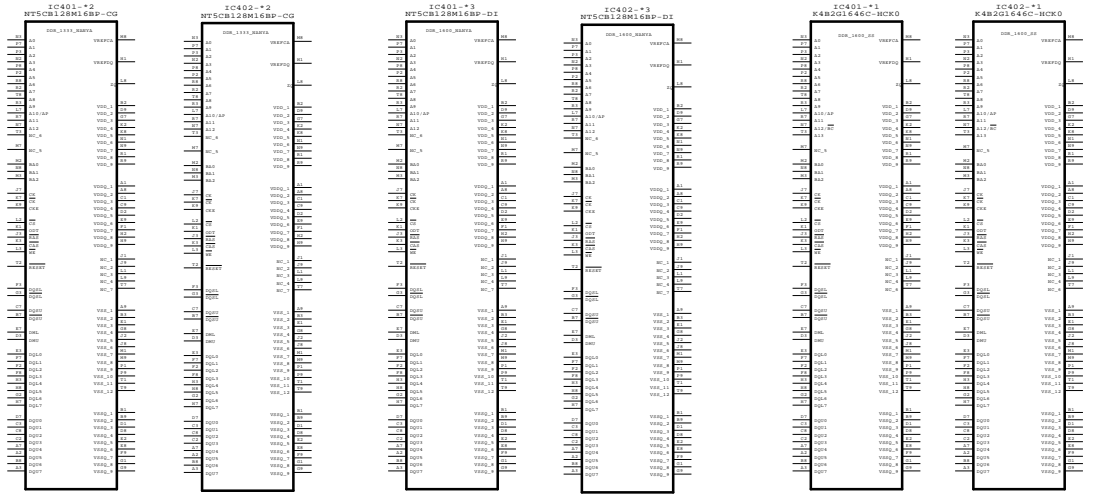
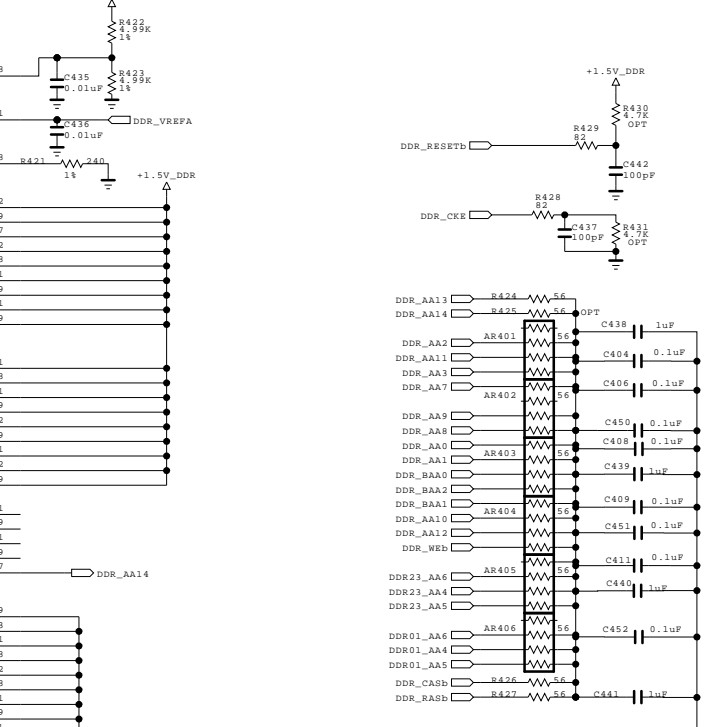
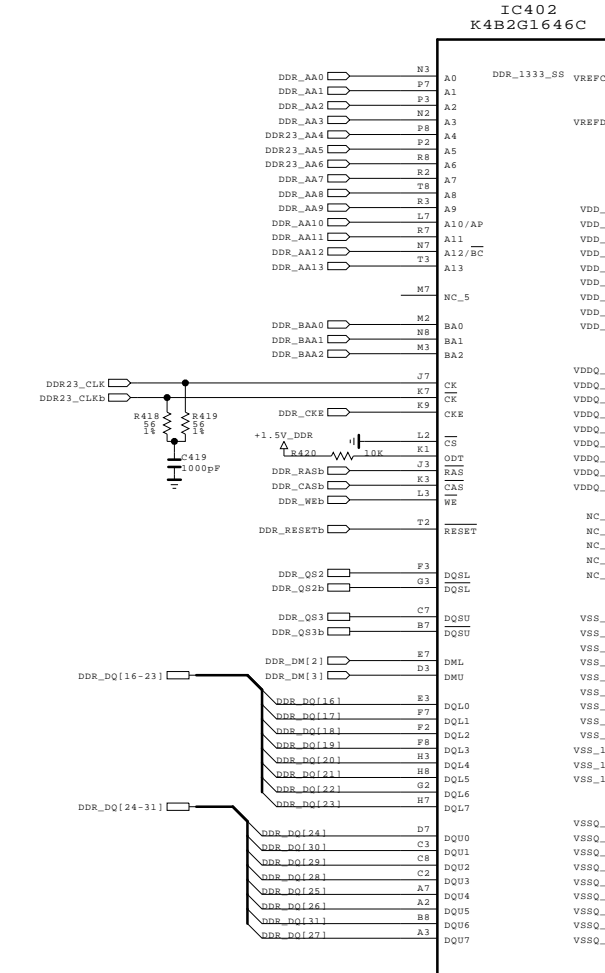
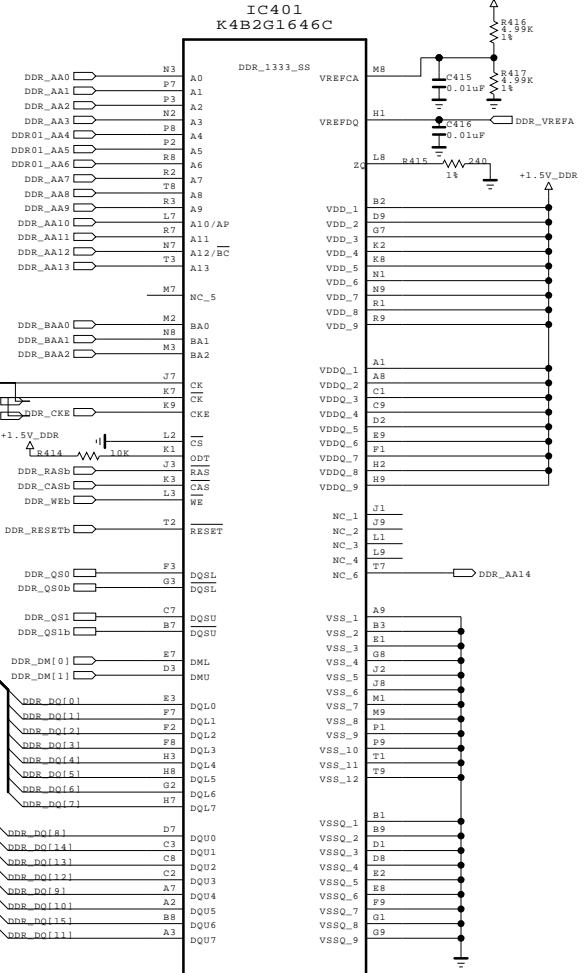
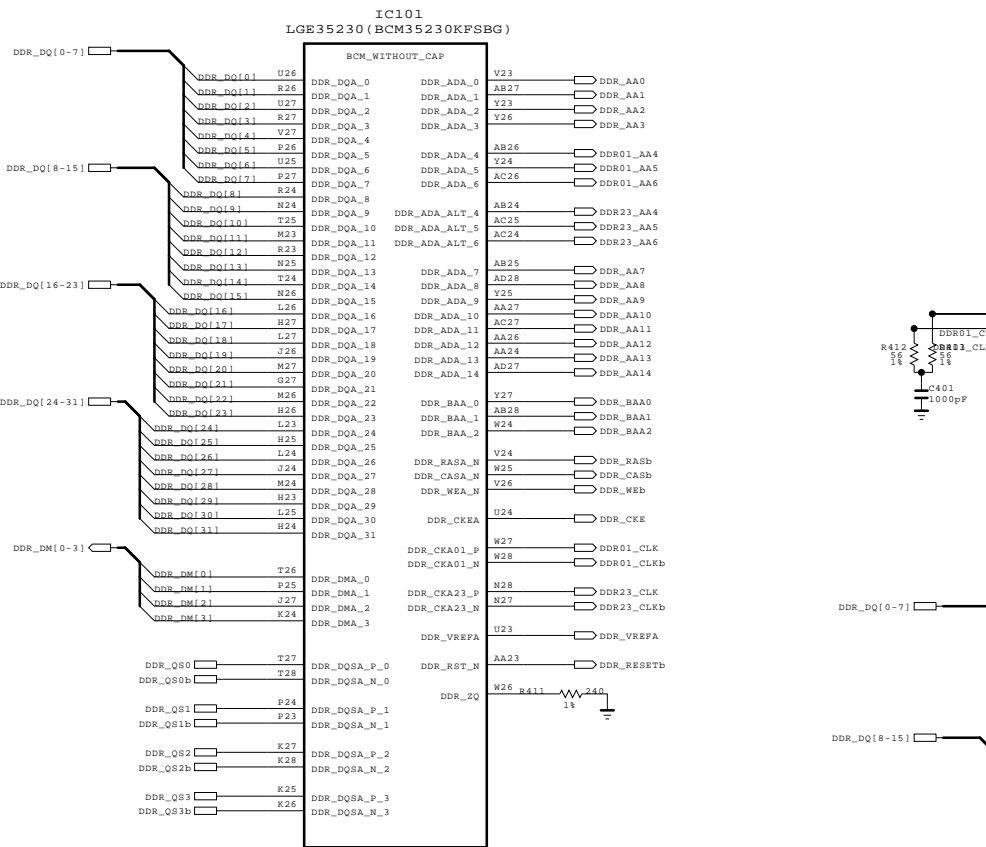

THE SYMBOL MARK OF THIS SCHEMATIC DIAGRAM INCORPORATES SPECIAL FEATURES IMPORTANT FOR PROTECTION FROM X-RADIATION. FILRE AND ELECTRICAL SHOCK HAZARDS, WHEN SERVICING IF IS ESSENTIAL THAT ONLY MANUFACTURES SPECIFIED PARTS BE USED FOR THE CRITICAL COMPONENTS IN THE SYMBOL MARK OF THE SCHEMATIC.

SECRET
 LGElectronics



MODEL	BCM35230	DATE	
BLOCK	MAIN DDR	SHEET	04

For Debug

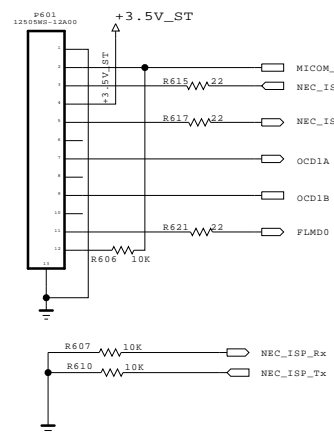

EEPROM for Micom

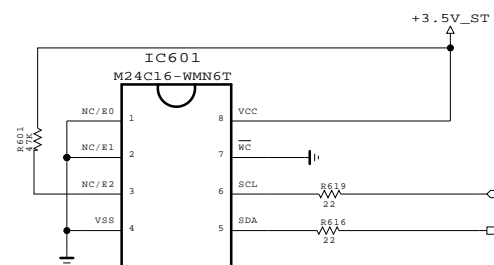

MICOM MODEL OPTION

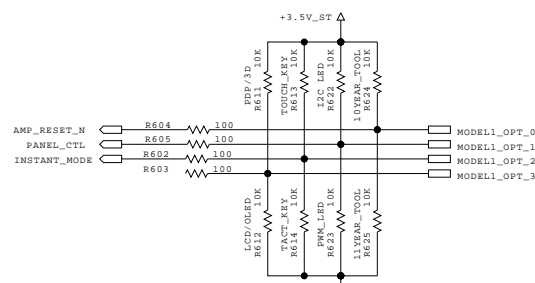

MODEL OPTION

PIN NAME	PIN NO.	HIGH	LOW
MODEL_OPT_0	8	10YEAR_TOOL (10 SENSOR)	11YEAR_TOOL (11 SENSOR)
MODEL_OPT_1	11	I2C_LED	PWM_LED
MODEL_OPT_2	30	TOUCH_KEY	TACT_KEY
MODEL_OPT_3	31	PDP/3D	LCD/OLED

MODEL_OPT_3	LCD	PDP	OLED	3D
MODEL_OPT_3	0	1	0	1
MODEL_OPT_1	0	LOW_SMALL	TBD	HIGH
MODEL_OPT_2	0	1	0	1

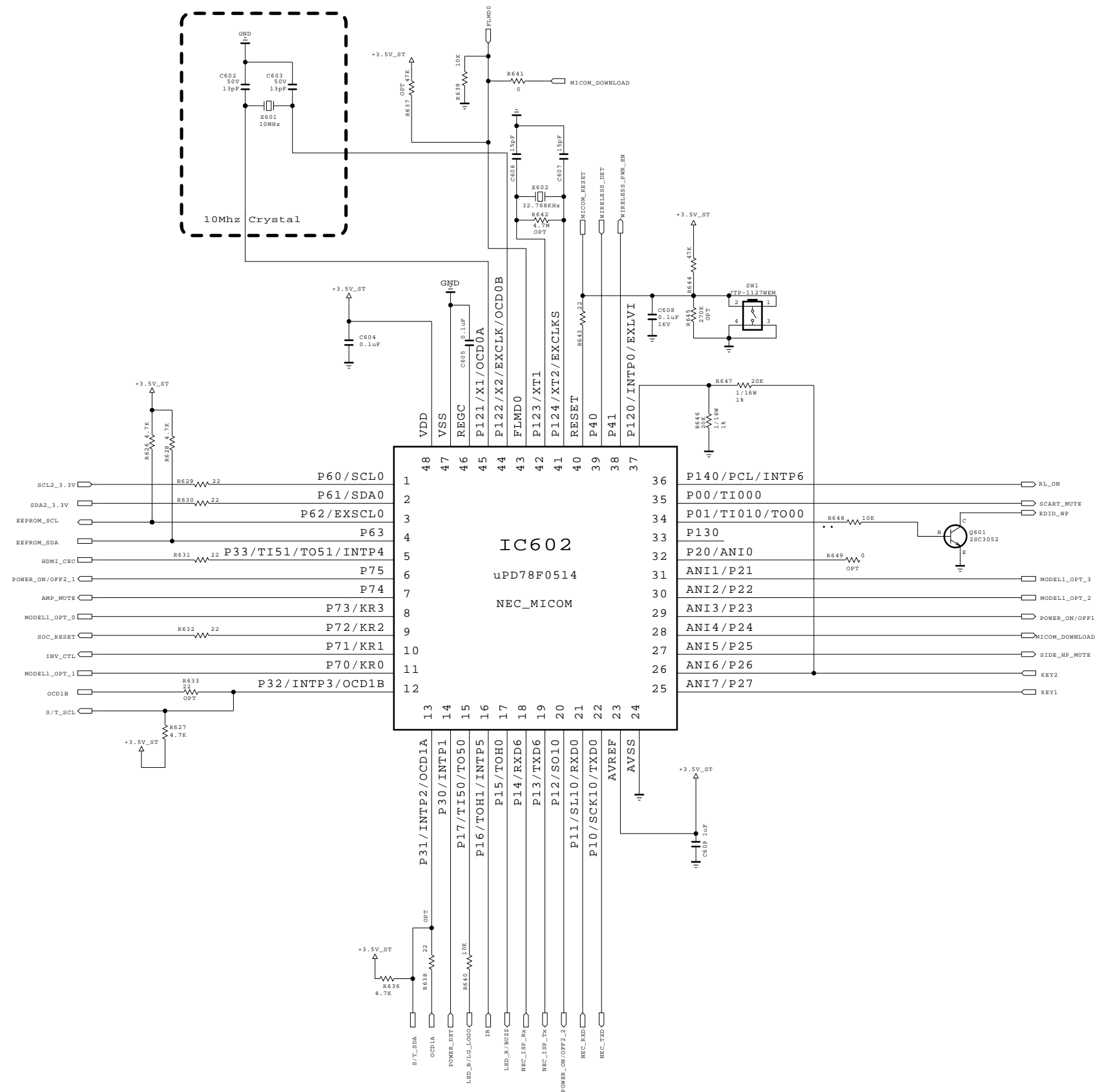

THE SYMBOL MARK OF THIS SCHEMATIC DIAGRAM INCORPORATES SPECIAL FEATURES IMPORTANT FOR PROTECTION FROM X-RADIATION. FILRE AND ELECTRICAL SHOCK HAZARDS, WHEN SERVICING IF IS ESSENTIAL THAT ONLY MANUFACTURES SPECIFIED PARTS BE USED FOR THE CRITICAL COMPONENTS IN THE SYMBOL MARK OF THE SCHEMATIC.

SECRET
LGElectronics



MODEL	BCM35230	DATE	
BLOCK	MICOM	SHEET	6 / 50

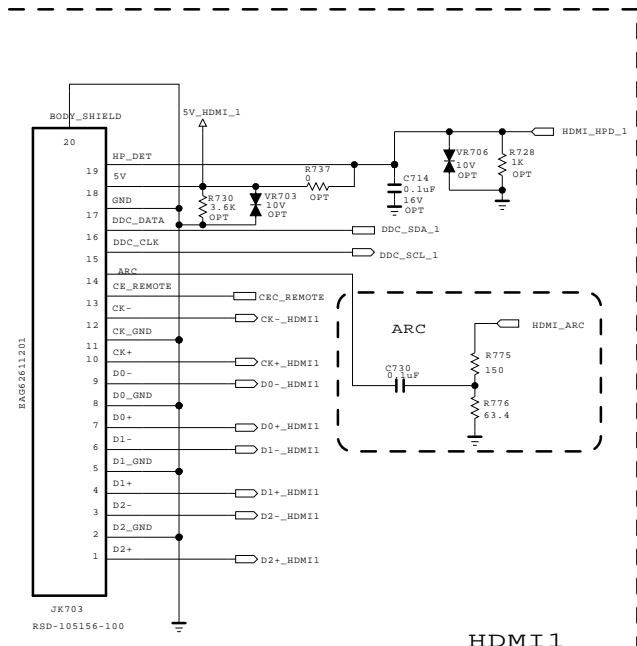

HDMI 1

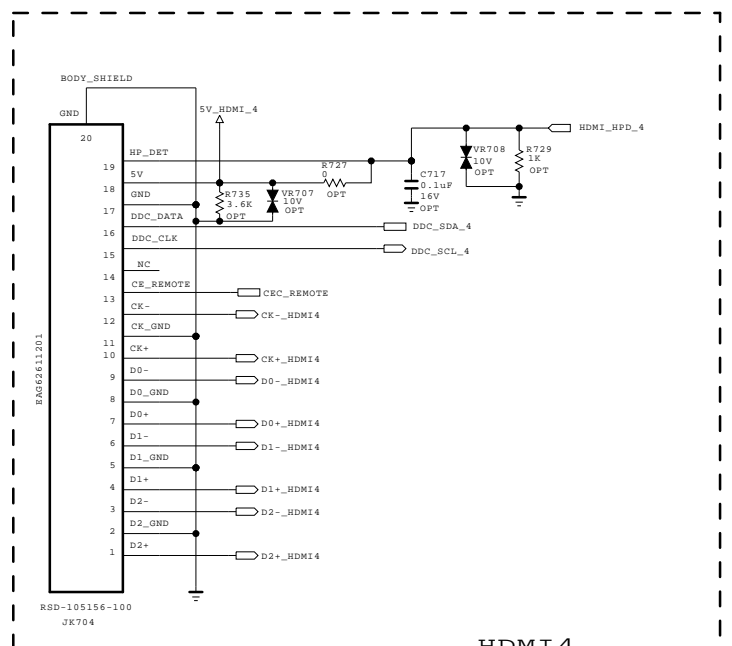

HDMI 4

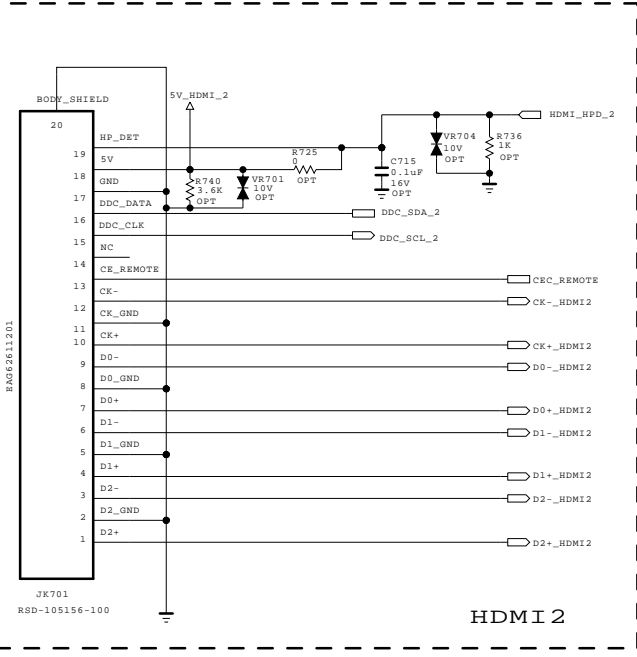

HDMI 2

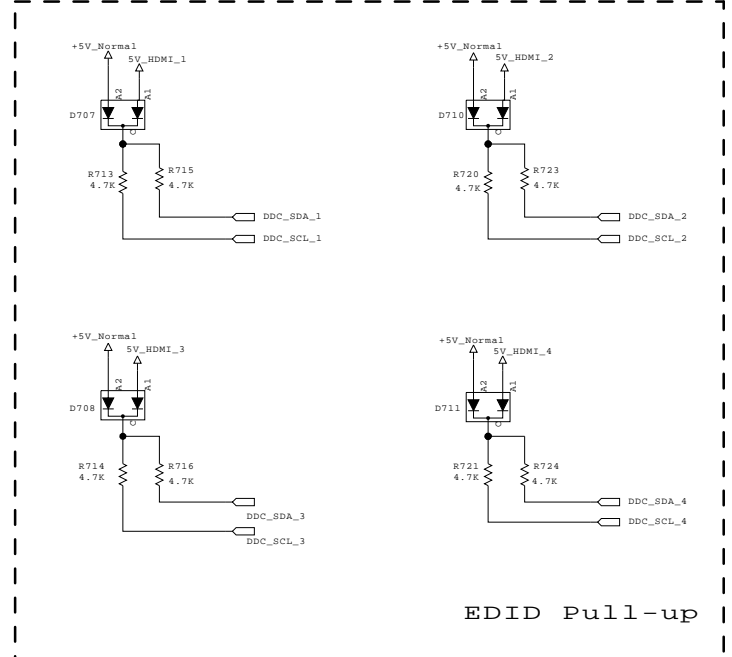

EDID Pull-up

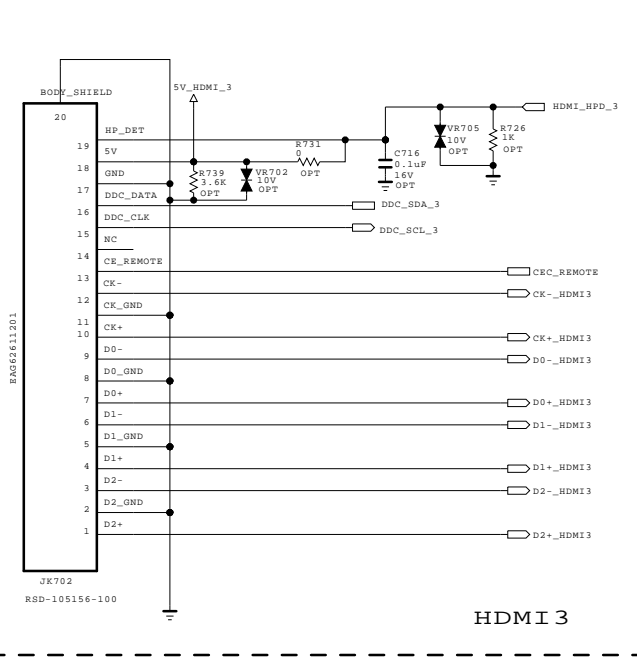

HDMI 3

DUAL COMPONENT	
D707, D708 D710, D711	1ST : ODD184009AA 2ND : ODSIH00028A
D713	1ST : T-BAT54_SUZH0, 2ND : ODS00138A

* HDMI CEC

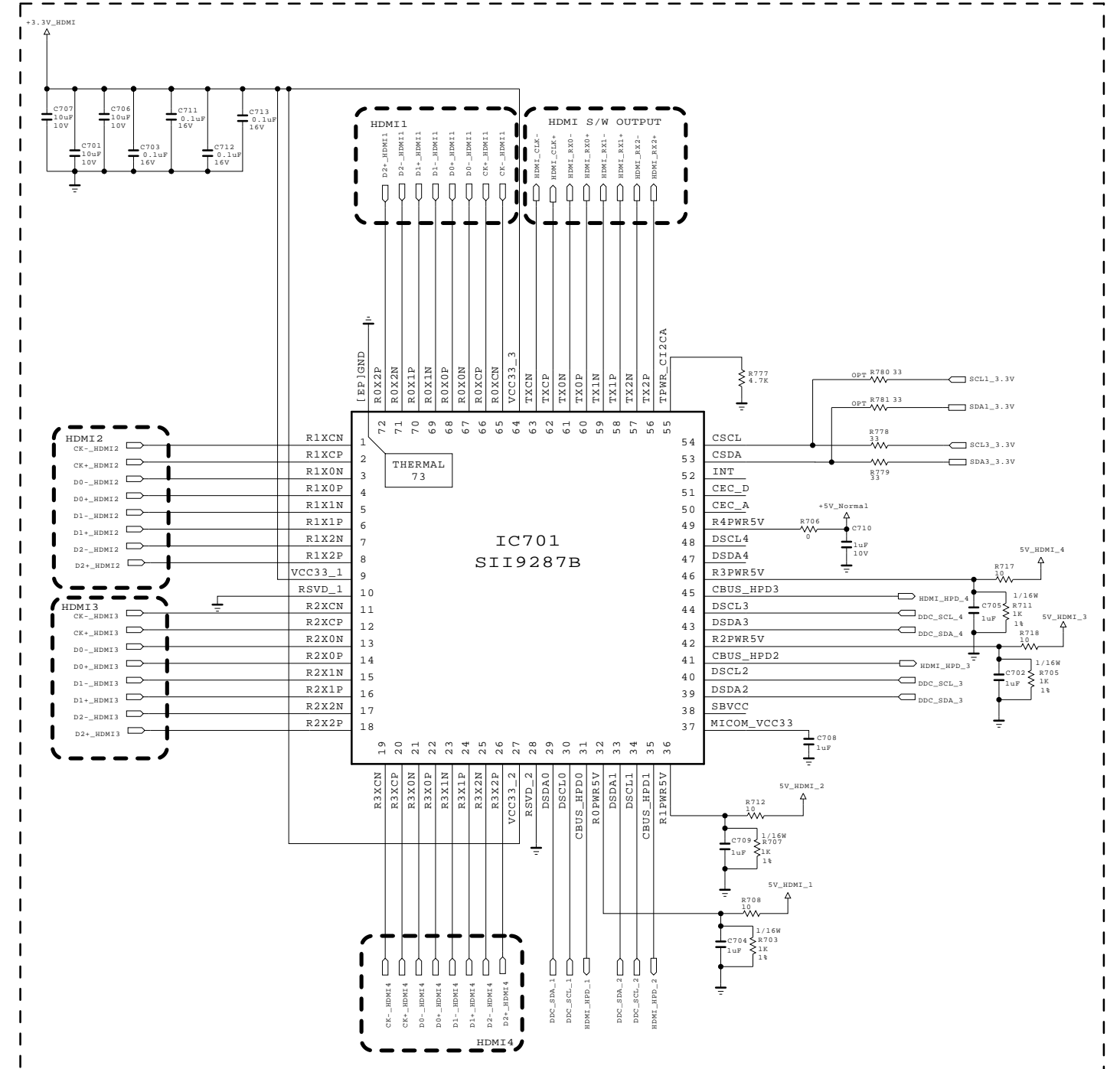
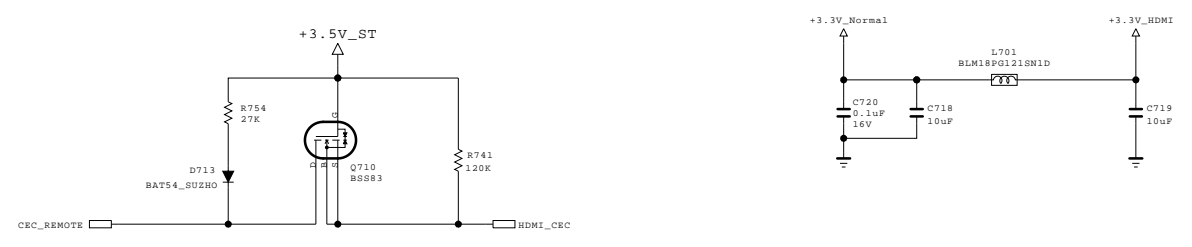

THE SYMBOL MARK OF THIS SCHEMATIC DIAGRAM INCORPORATES SPECIAL FEATURES IMPORTANT FOR PROTECTION FROM X-RADIATION. FILRE AND ELECTRICAL SHOCK HAZARDS, WHEN SERVICING IF IS ESSENTIAL THAT ONLY MANUFACTURES SPECIFIED PARTS BE USED FOR THE CRITICAL COMPONENTS IN THE SYMBOL MARK OF THE SCHEMATIC.

SECRET
LGElectronics



MODEL	BCM35230	DATE	
BLOCK	HDMI	SHEET	7 / 31

RGB PC

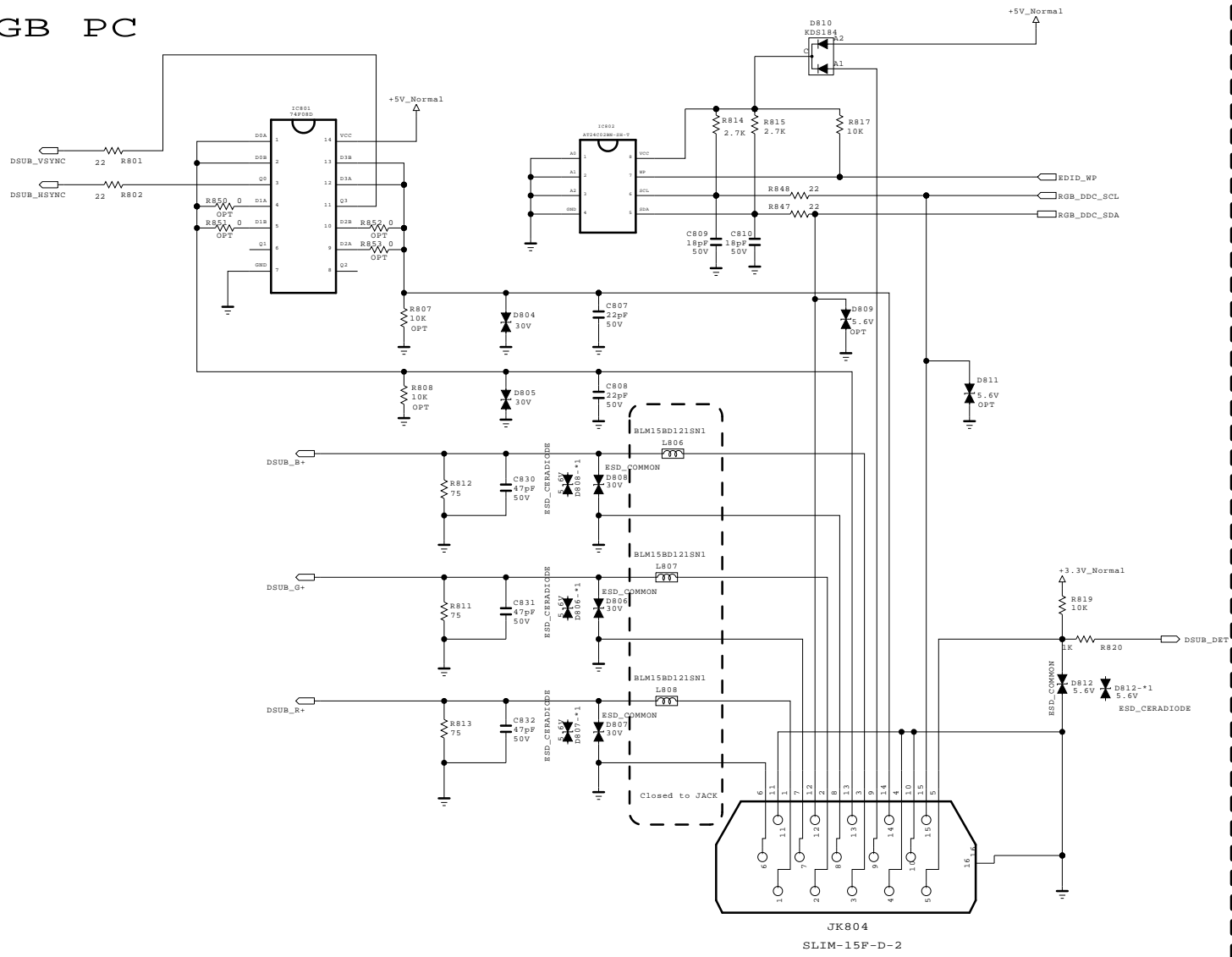

EARPHON JACK

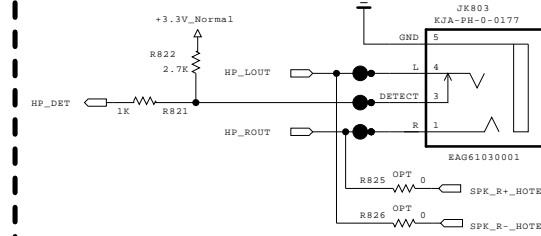

DUAL COMPONENT	
D804, D805, D806 D807, D809, D813 D814	1ST : EAH39491601, 2ND : EAH33945901
D810	1ST : ODD184009AA, 2ND : ODSIH00028A
Q801	1ST : OTRIY80001A, 2ND : OTR387500AA
IC805	1ST : EAN61151201, 2ND : EAN61130001

EARPHONE AMP

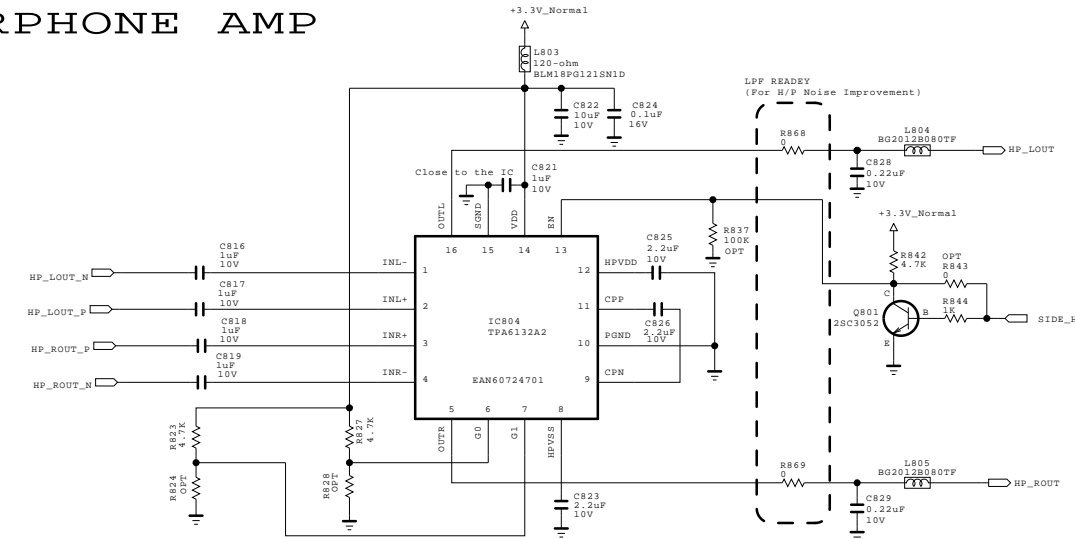

PC AUDIO

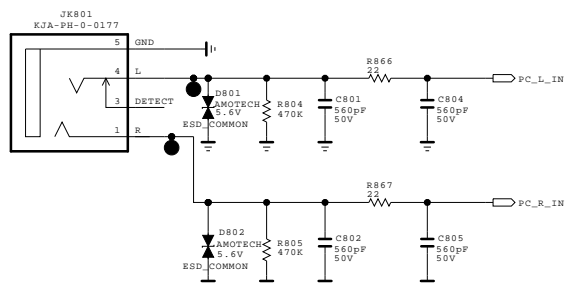

SPDIF OUT

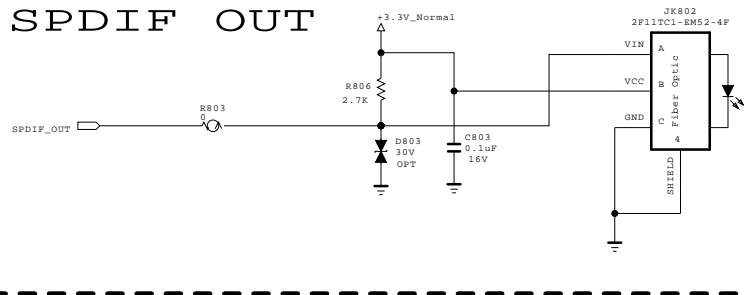

RS232C

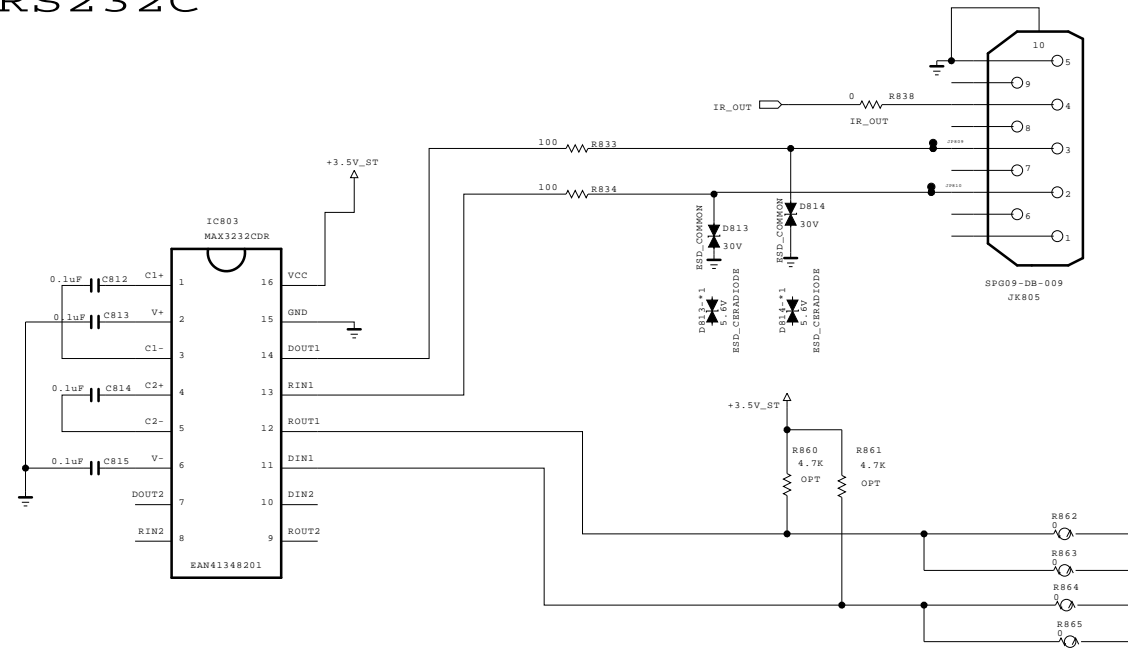

THE SYMBOL MARK OF THIS SCHEMATIC DIAGRAM INCORPORATES SPECIAL FEATURES IMPORTANT FOR PROTECTION FROM X-RADIATION. FILRE AND ELECTRICAL SHOCK HAZARDS, WHEN SERVICING IF IS ESSENTIAL THAT ONLY MANUFACTURES SPECIFIED PARTS BE USED FOR THE CRITICAL COMPONENTS IN THE SYMBOL MARK OF THE SCHEMATIC.

SECRET
LGElectronics



MODEL	BCM35230	DATE	2010.10.21
BLOCK	COMMON JACK	SHEET	8 / 58

DUAL COMPONENT	
Q901,Q902,Q903 Q904,Q905,Q906	1ST : OTRIY80001A 2ND : OTR387500AA
D903,D904 D905,D906	1ST : EAH42720601, 2ND : EAH60994401

IR & KEY

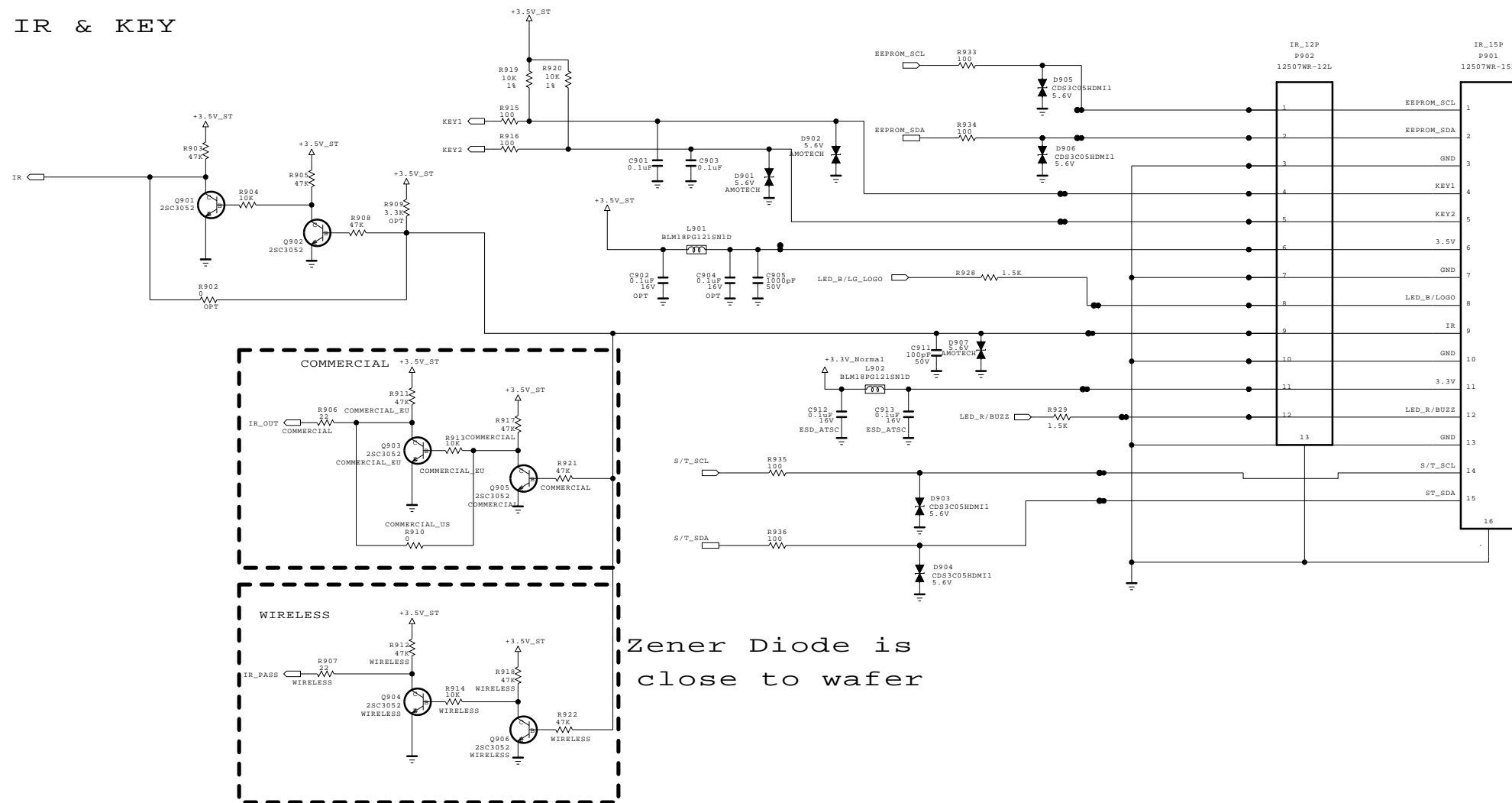

Zener Diode is close to wafer

THE SYMBOL MARK OF THIS SCHEMATIC DIAGRAM INCORPORATES SPECIAL FEATURES IMPORTANT FOR PROTECTION FROM X-RADIATION. FILRE AND ELECTRICAL SHOCK HAZARDS, WHEN SERVICING IF IS ESSENTIAL THAT ONLY MANUFACTURES SPECIFIED PARTS BE USED FOR THE CRITICAL COMPONENTS IN THE SYMBOL MARK OF THE SCHEMATIC.

SECRET
LGElectronics



MODEL	BCM35230	DATE	
BLOCK	IR/KEY	SHEET	9 / 50

WIRELESS READY MODEL

DUAL COMPONENT	
D1001,D1002	1ST : EAH42720601 2ND : EAH60994401
Q1001	1ST : EBK61012601, 2ND : OTRDI80002A
Q1002	1ST : EBK60752501, 2ND : EBK61011501

Wireless power

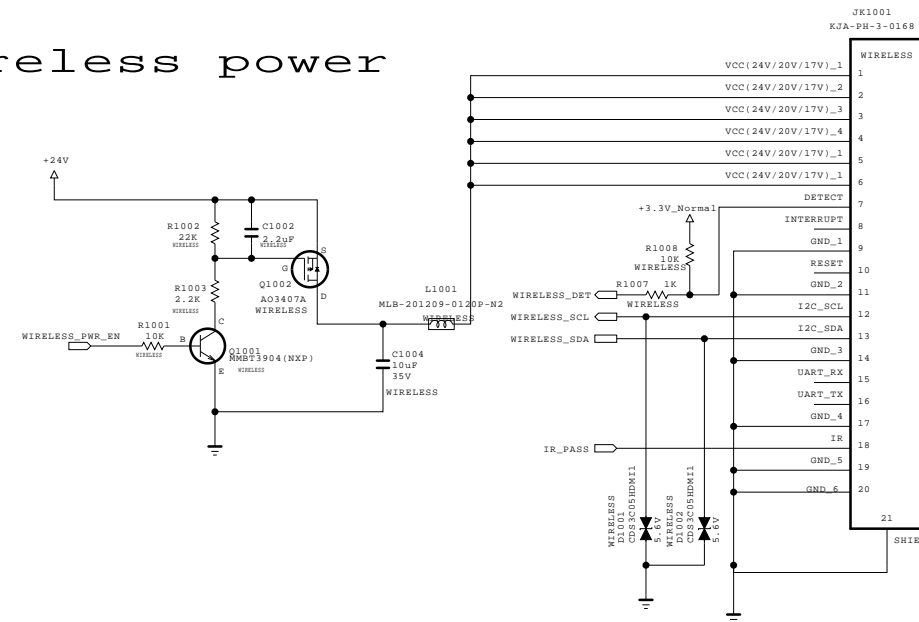

Wireless I2C connection with I2C_1
Address : 0X20

WIRELESS_SCL — R1005 — SCL2_3.3V
WIRELESS_SDA — R1006 — SDA2_3.3V

THE SYMBOL MARK OF THIS SCHEMATIC DIAGRAM INCORPORATES SPECIAL FEATURES IMPORTANT FOR PROTECTION FROM X-RADIATION. FILRE AND ELECTRICAL SHOCK HAZARDS, WHEN SERVICING IF IS ESSENTIAL THAT ONLY MANUFACTURES SPECIFIED PARTS BE USED FOR THE CRITICAL COMPONENTS IN THE SYMBOL MARK OF THE SCHEMATIC.

SECRET
LGElectronics



MODEL	BCM35230	DATE	
BLOCK	WIRELESS	SHEET	10 / 50

CVBS 1 PHONE JACK

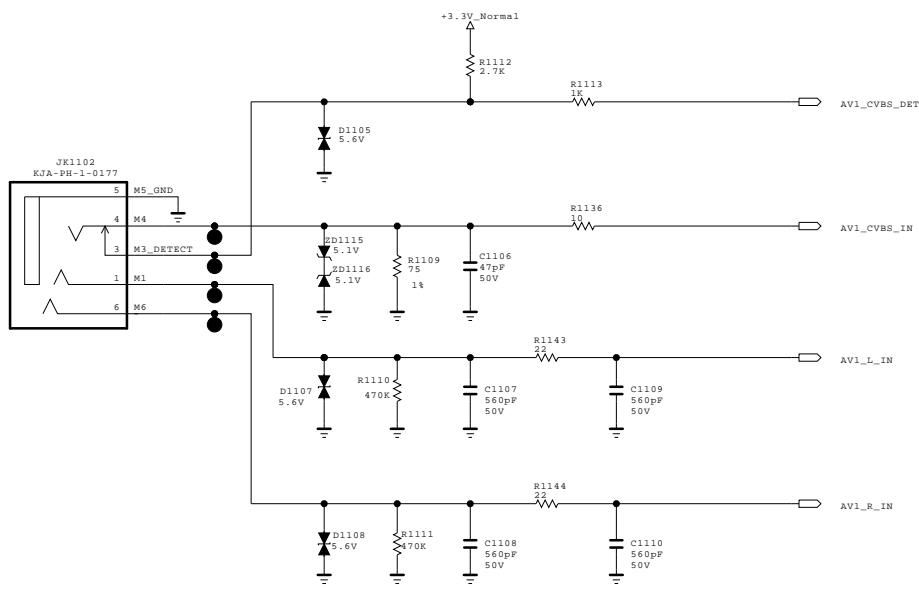

CVBS2 REAR JACK

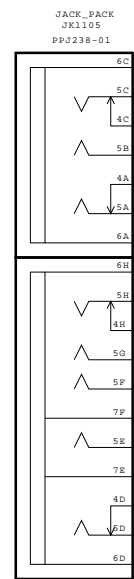
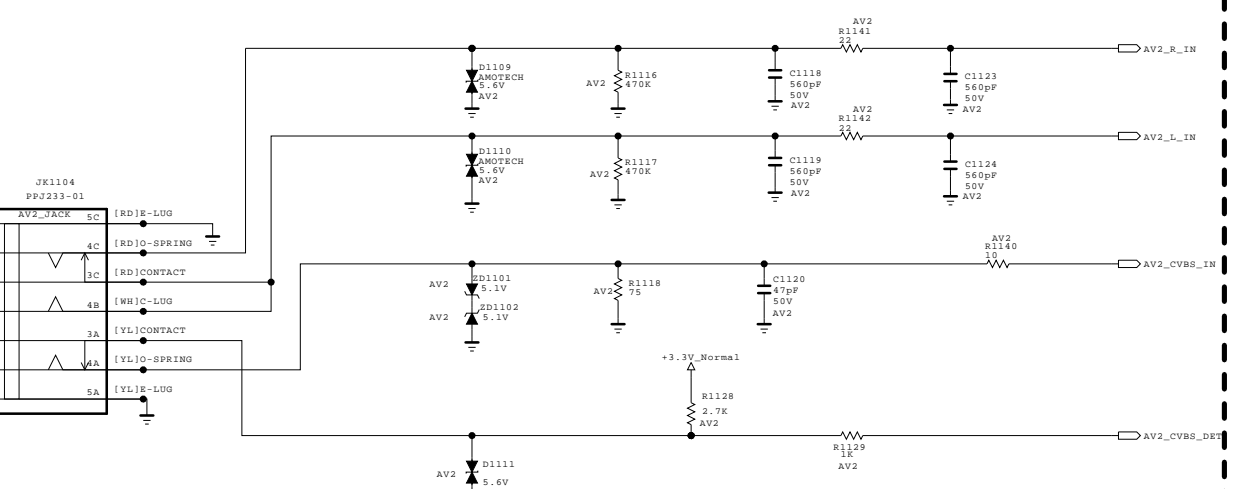

COMP2 REAR JACK

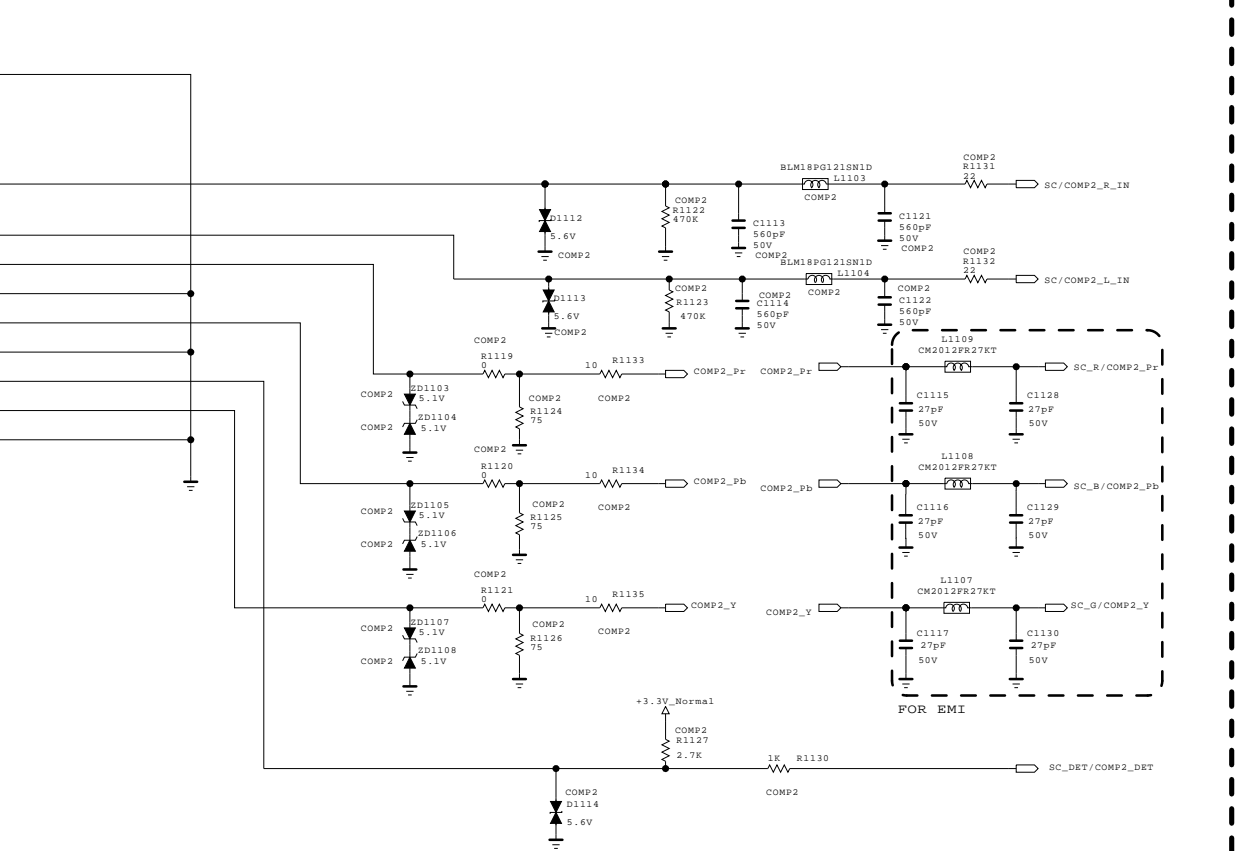

COMPONENT 1 PHONE JACK

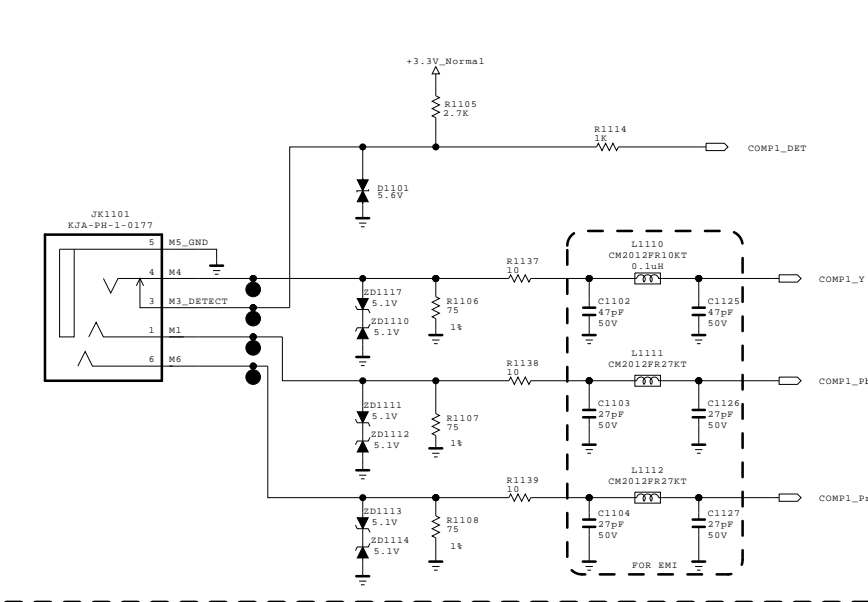

THE SYMBOL MARK OF THIS SCHEMATIC DIAGRAM INCORPORATES SPECIAL FEATURES IMPORTANT FOR PROTECTION FROM X-RADIATION. FILRE AND ELECTRICAL SHOCK HAZARDS, WHEN SERVICING IF IS ESSENTIAL THAT ONLY MANUFACTURES SPECIFIED PARTS BE USED FOR THE CRITICAL COMPONENTS IN THE SYMBOL MARK OF THE SCHEMATIC.

SECRET
LGElectronics



MODEL	BCM35230	DATE	
BLOCK	COMP / AV	SHEET	11

TI solution M_REMOTE OPTION

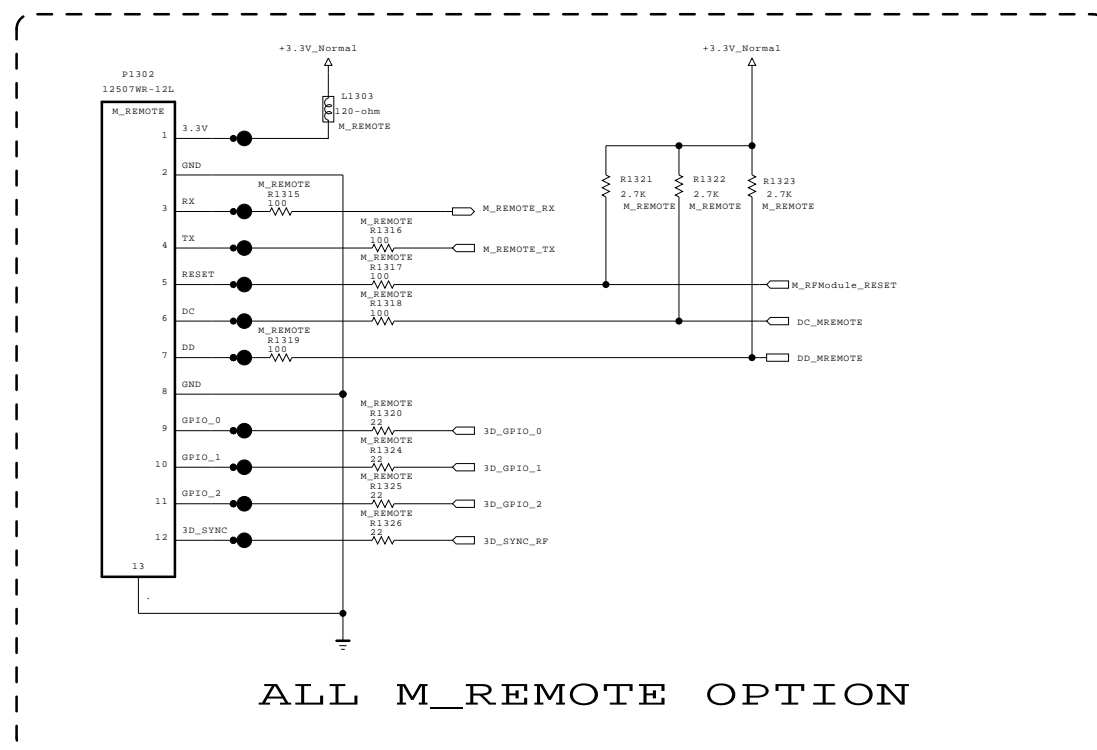

THE SYMBOL MARK OF THIS SCHEMATIC DIAGRAM INCORPORATES SPECIAL FEATURES IMPORTANT FOR PROTECTION FROM X-RADIATION. FILRE AND ELECTRICAL SHOCK HAZARDS, WHEN SERVICING IF IS ESSENTIAL THAT ONLY MANUFACTURES SPECIFIED PARTS BE USED FOR THE CRITICAL COMPONENTS IN THE SYMBOL MARK OF THE SCHEMATIC.

SECRET
LGElectronics



MODEL	BCM35230	DATE	
BLOCK	M_REMOCON	SHEET	13 / 50

Ethernet Block

DUAL COMPONENT	
D1401, D1402 D1403, D1404 D1405, D1406	1ST : EAH42720601 2ND : EAH60994401

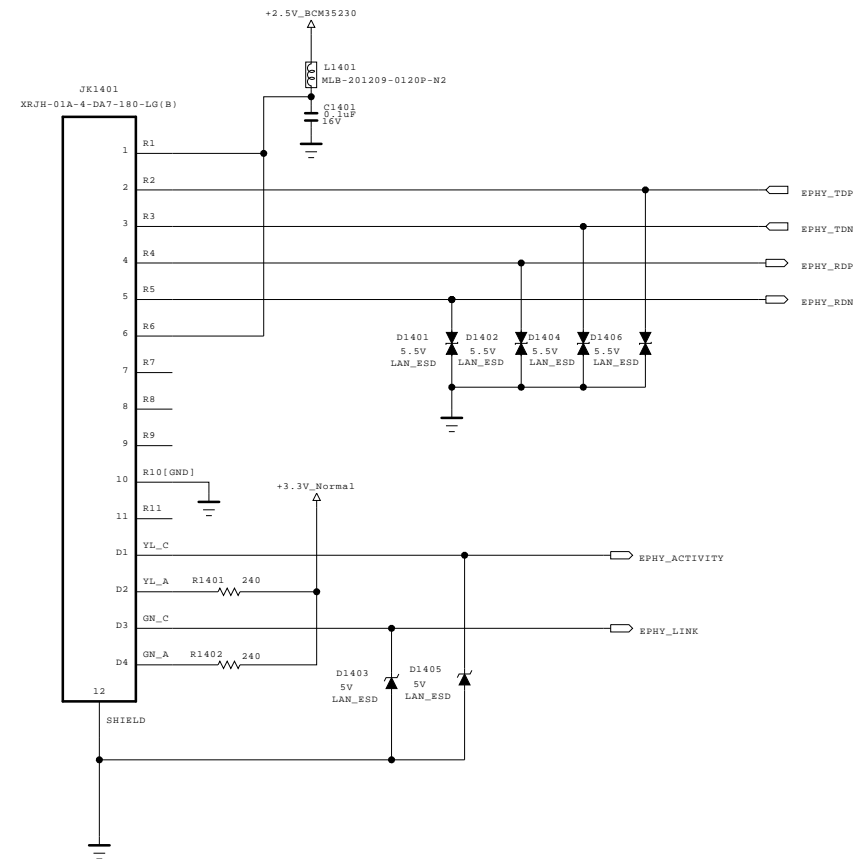

THE SYMBOL MARK OF THIS SCHEMATIC DIAGRAM INCORPORATES SPECIAL FEATURES IMPORTANT FOR PROTECTION FROM X-RADIATION. FILRE AND ELECTRICAL SHOCK HAZARDS, WHEN SERVICING IF IS ESSENTIAL THAT ONLY MANUFACTURES SPECIFIED PARTS BE USED FOR THE CRITICAL COMPONENTS IN THE SYMBOL MARK OF THE SCHEMATIC.

SECRET
LGElectronics



MODEL	BCM35230	DATE	
BLOCK	ETHERNET	SHEET	14 / 50

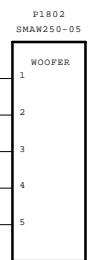
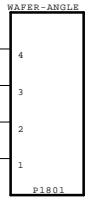
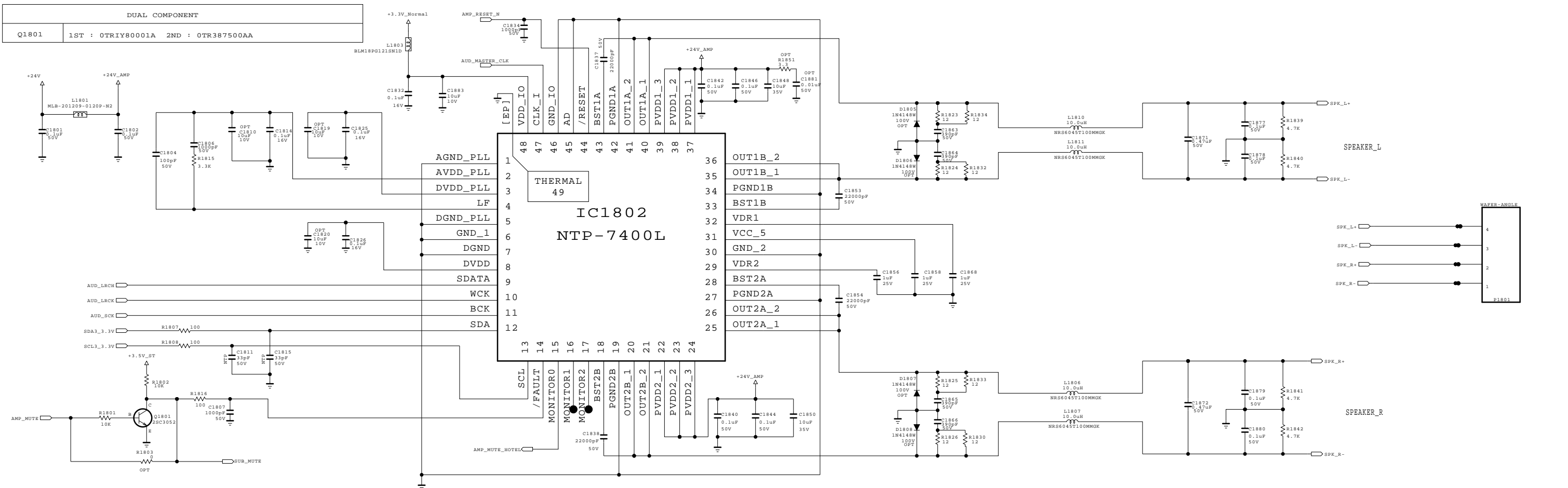

WOOFER AMP.

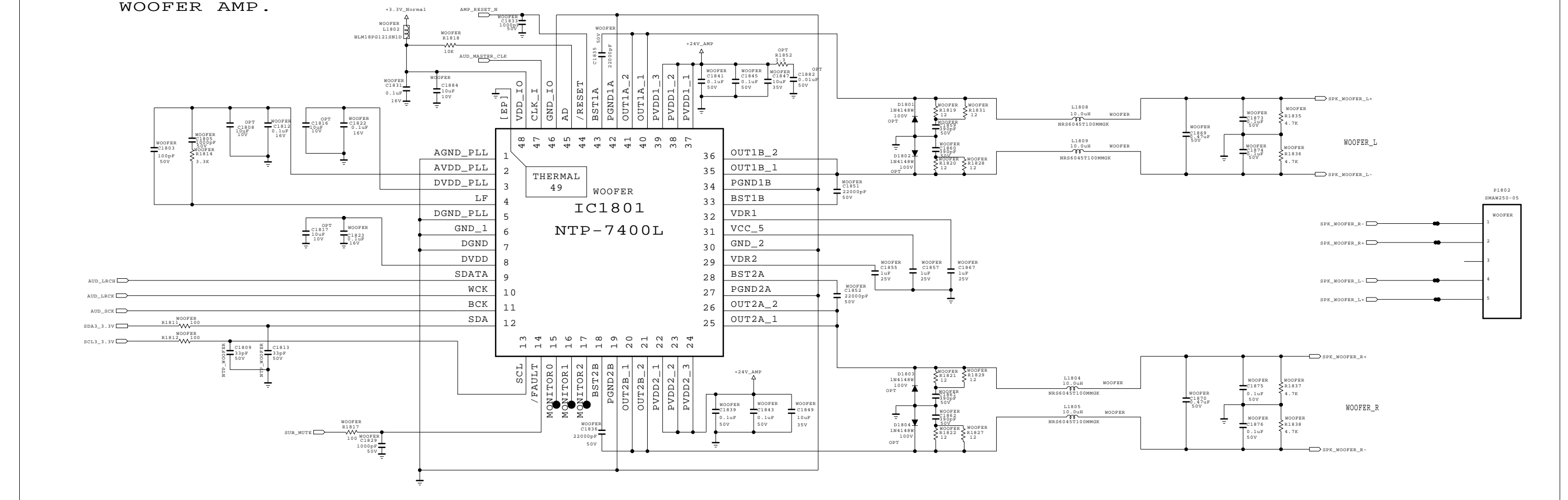

THE SYMBOL MARK OF THIS SCHEMATIC DIAGRAM INCORPORATES SPECIAL FEATURES IMPORTANT FOR PROTECTION FROM X-RADIATION. FILRE AND ELECTRICAL SHOCK HAZARDS, WHEN SERVICING IF IS ESSENTIAL THAT ONLY MANUFACTURES SPECIFIED PARTS BE USED FOR THE CRITICAL COMPONENTS IN THE SYMBOL MARK OF THE SCHEMATIC.

SECRET
LGElectronics



MODEL	BCM35230	DATE	
BLOCK	AUDIO[NEO]	SHEET	18 / 50

DUAL COMPONENT		
Q1901	1ST : OTRIY80001A, 2ND : OTR387500AA	
Q1902	1ST : EBK60752501, 2ND : EBK61011501	
IC1904	1ST : OISTLPH062A, 2ND : EAN40055001	

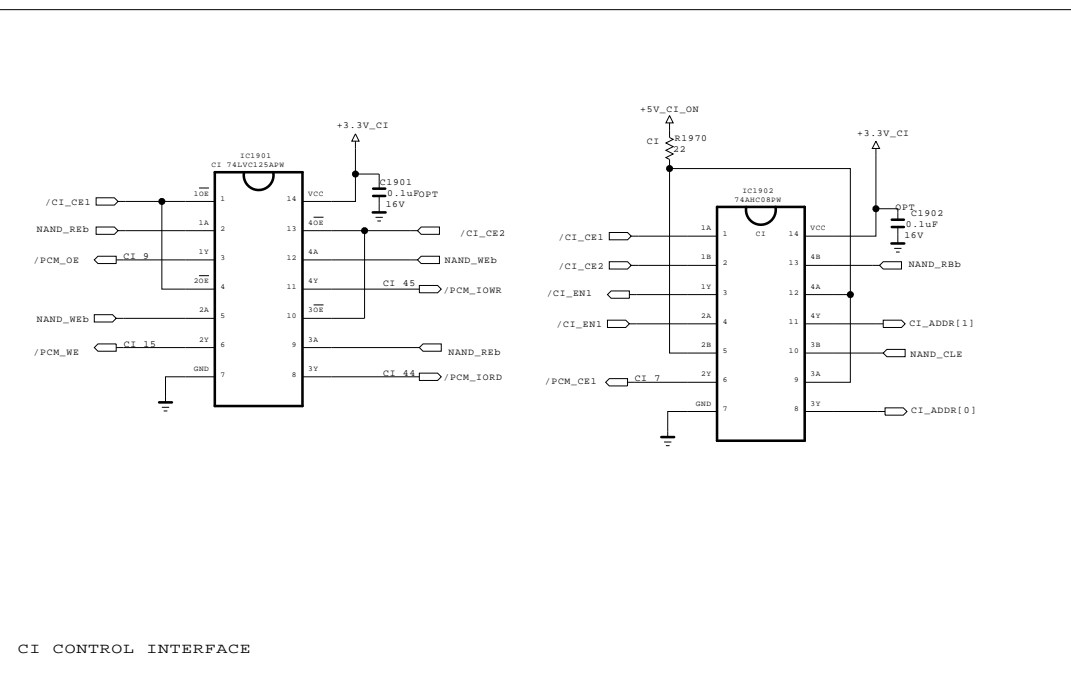
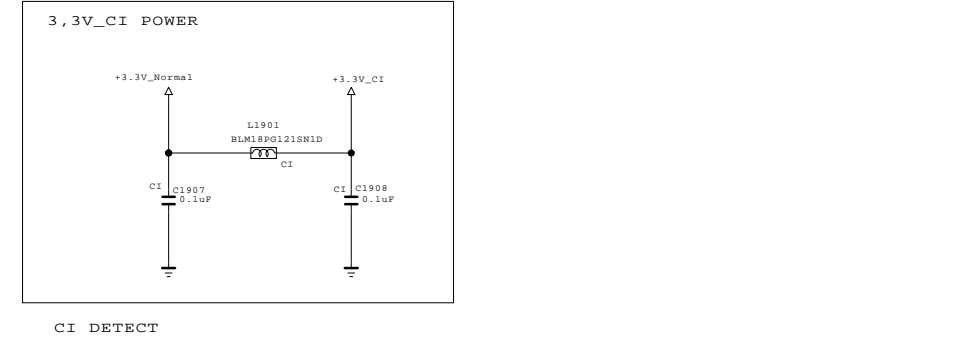
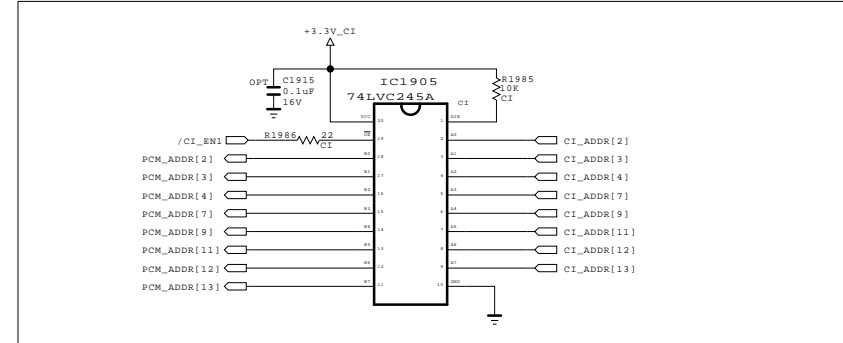
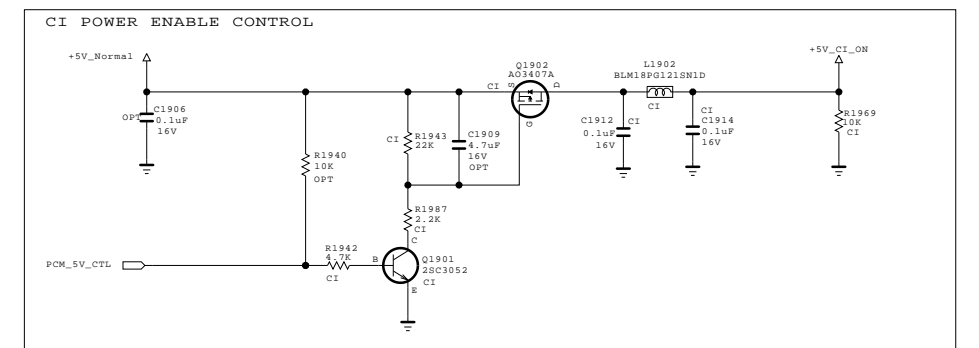
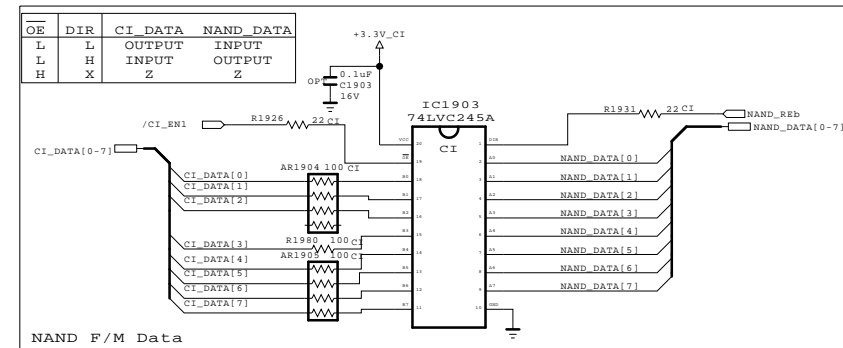
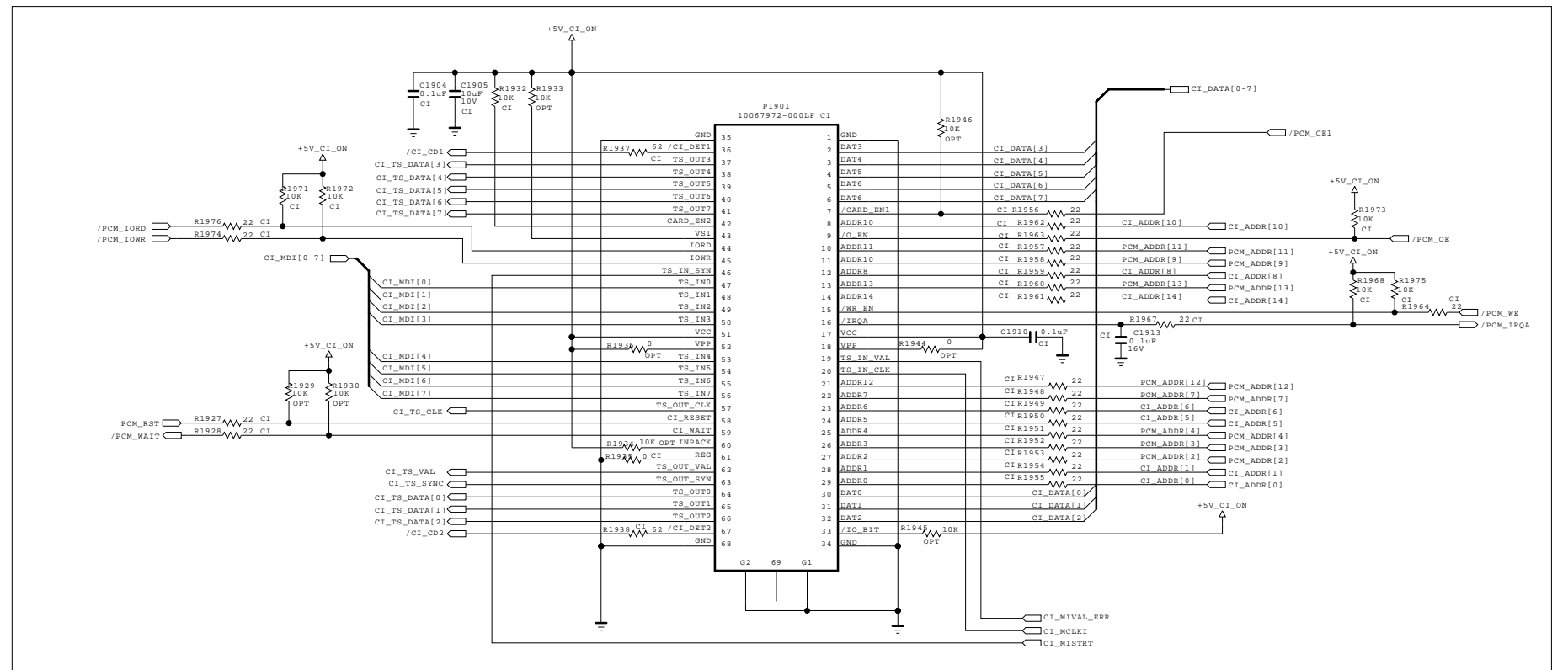
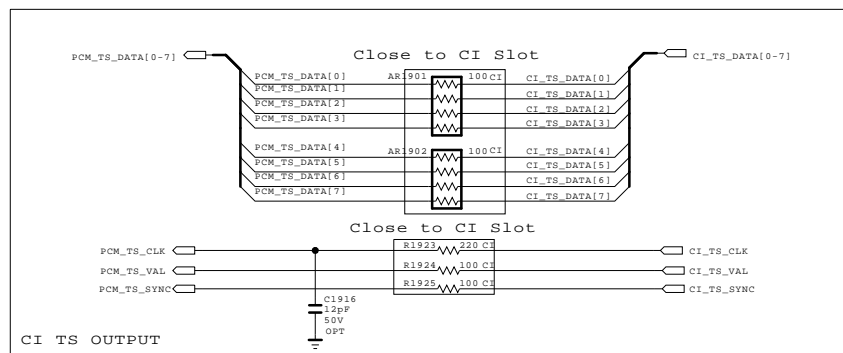
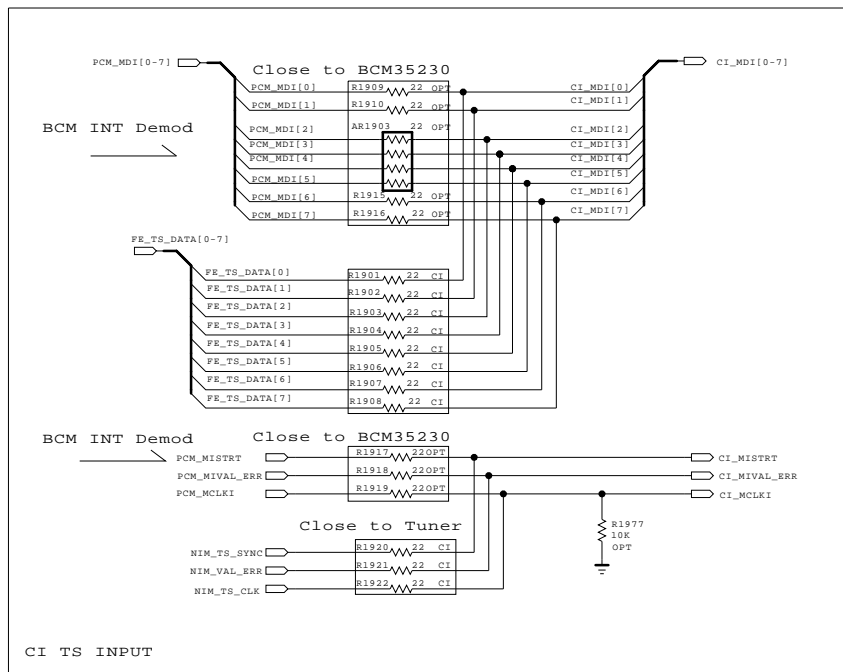

THE ⚠ SYMBOL MARK OF THIS SCHEMATIC DIAGRAM INCORPORATES SPECIAL FEATURES IMPORTANT FOR PROTECTION FROM X-RADIATION. FILRE AND ELECTRICAL SHOCK HAZARDS, WHEN SERVICING IF IS ESSENTIAL THAT ONLY MANUFACTURES SPECIFIED PARTS BE USED FOR THE CRITICAL COMPONENTS IN THE ⚠ SYMBOL MARK OF THE SCHEMATIC.

SECRET
LGElectronics



MODEL	BCM35230	DATE	2010.11.11
BLOCK	CI	SHEET	19 / 58

OPTION TABLE							
H/NIM (EU)	H/NIM (AU, Latin)	H/NIM (Brazil, Taiwan)	F/NIM_T/C	F/NIM_T2	F/NIM_CN (China)	F/NIM_Brazil (Brazil)	DVB-T/C/S2 (Eu, Aisa)
Non_DVB_S	Non_DVB_S	Non_DVB_S	Non_DVB_S	Non_DVB_S	Non_DVB_S	Non_DVB_S	DVB_S
H/NIM	H/NIM	H/NIM	F/NIM	F/NIM	F/NIM	F/NIM	F/NIM
BOOSTER	BOOSTER	BOOSTER	BOOSTER	BOOSTER	BOOSTER	BOOSTER	SCART
SCART		RF_SW_CTL	SCART	SCART	RF_SW_CTL	RF_SW_CTL	
					CN		
			EU_F/NIM	EU_F/NIM	CN_F/NIM_BR	CN_F/NIM_BR	TC_S_F/NIM
							TC_S_F/NIM

H/NIM & F/NIM & T/C/S2 Combo Tuner

NON_DVB_S: use H/NIM and F/NIM
 DVB_S: use DVB-T/C/S2 combo Tuner
 H/NIM: use H/NIM
 F/NIM: use F/NIM and DVB-T/C/S2 combo Tuner
 SCART: use Scart Jack
 CN : use China F/NIM
 BOOSTER: use BOOSTER_CTL
 RF_SW_CTL: use RF_SWITCH_CTL
 TC_S_F/NIM: use EU_DVB-T/C F/NIM
 CN_F/NIM_BR: use F/NIM(China, BRZIL)
 EU_F/NIM: use EU_F/NIM

DUAL COMPONENT	
IC2204	1ST:T-AP2114H(EAN61573601) / 2ND:T-TJ3940S (EAN61573501)

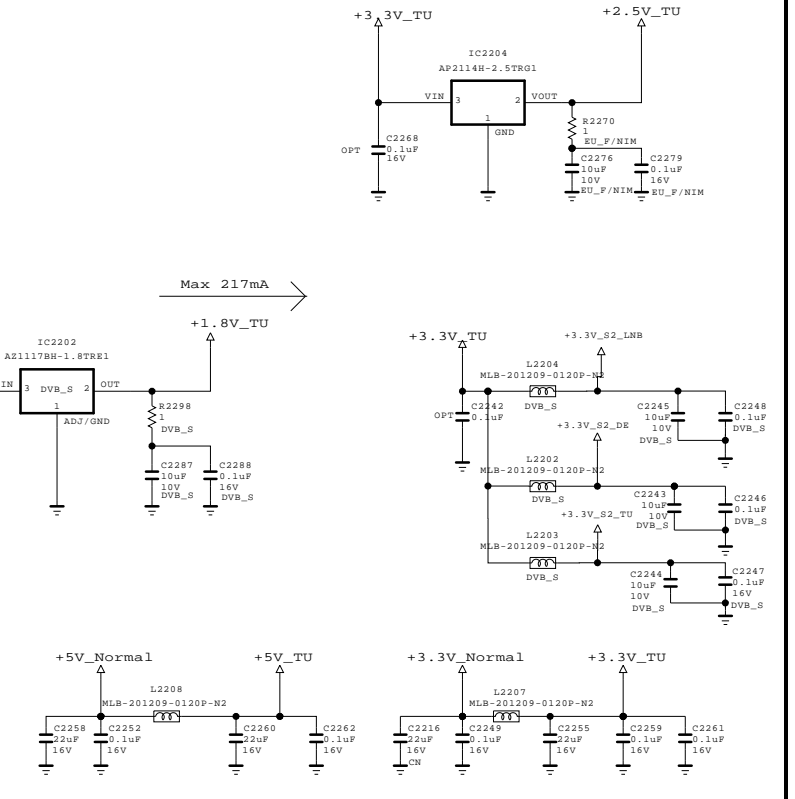
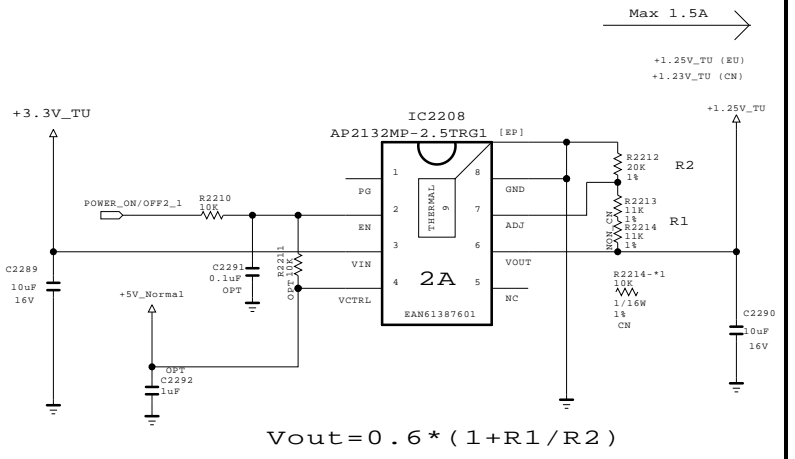
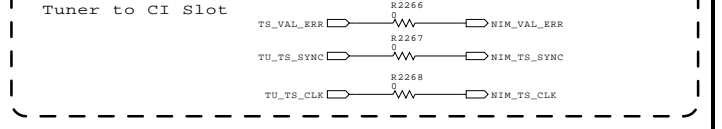
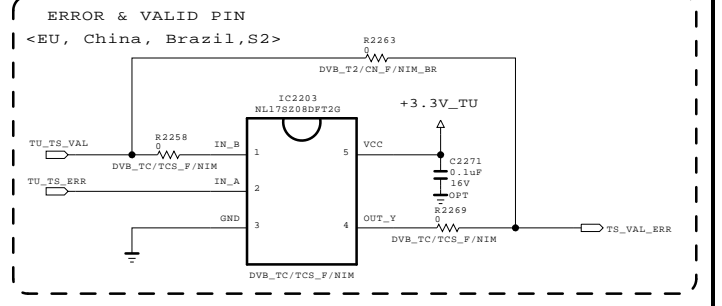
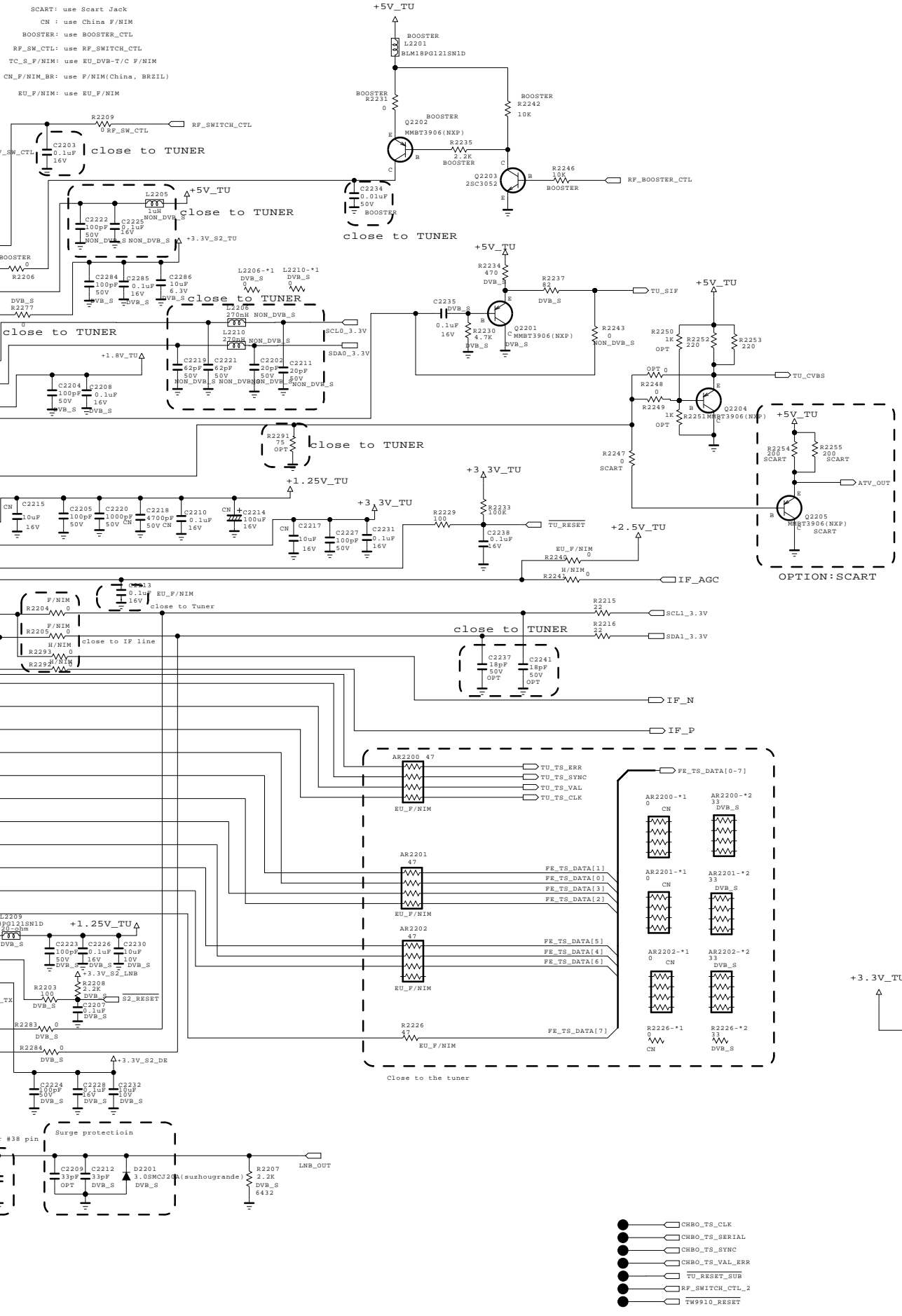
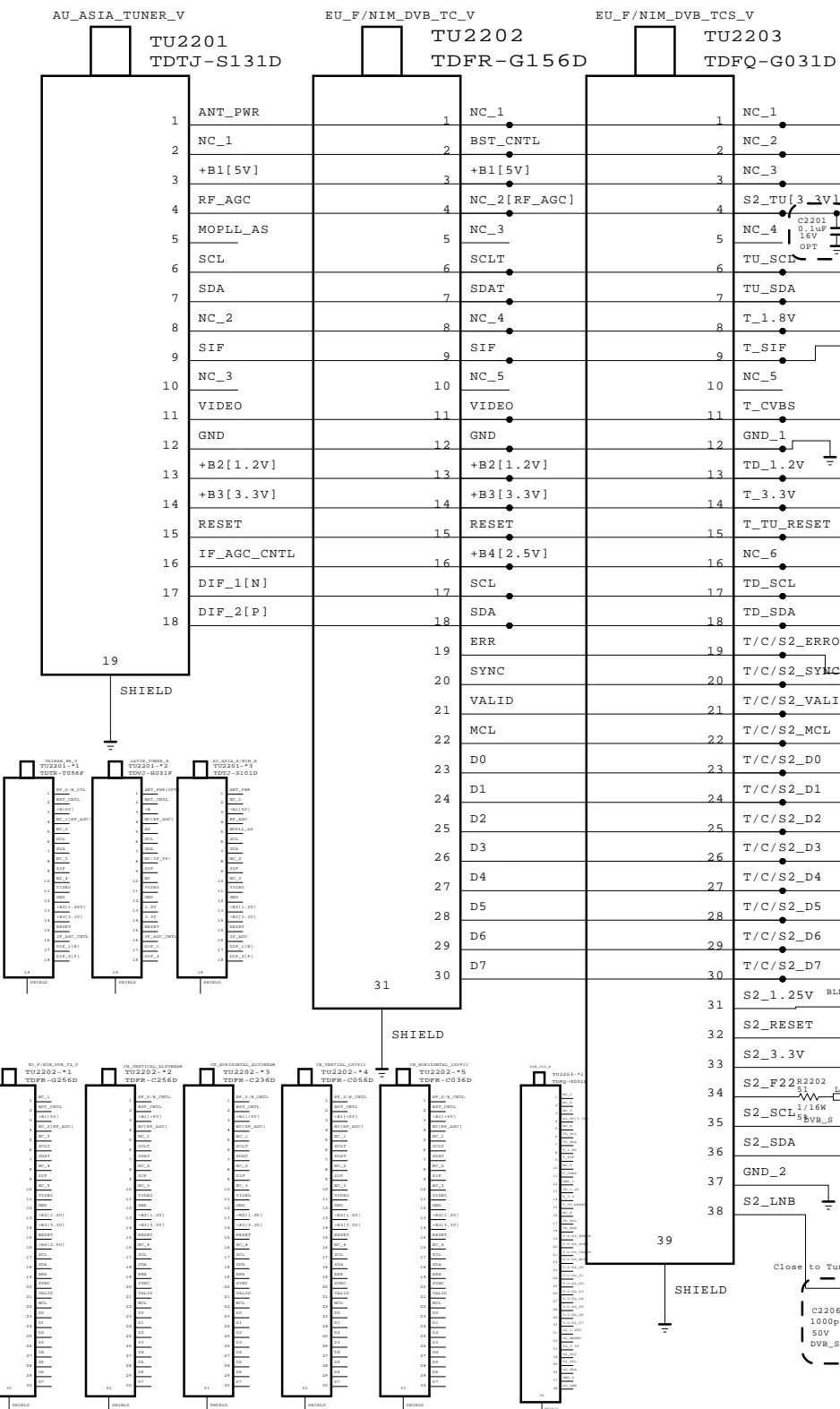

THE Δ SYMBOL MARK OF THIS SCHEMATIC DIAGRAM INCORPORATES SPECIAL FEATURES IMPORTANT FOR PROTECTION FROM X-RADIATION. FILRE AND ELECTRICAL SHOCK HAZARDS, WHEN SERVICING IF IS ESSENTIAL THAT ONLY MANUFACTURES SPECIFIED PARTS BE USED FOR THE CRITICAL COMPONENTS IN THE Δ SYMBOL MARK OF THE SCHEMATIC.

SECRET
 LGElectronics



MODEL	BCM35230	DATE	
BLOCK	TUNER SINGLE	SHEET	70

DVB-S2 LNB Part Allegro

(Option:LNB)

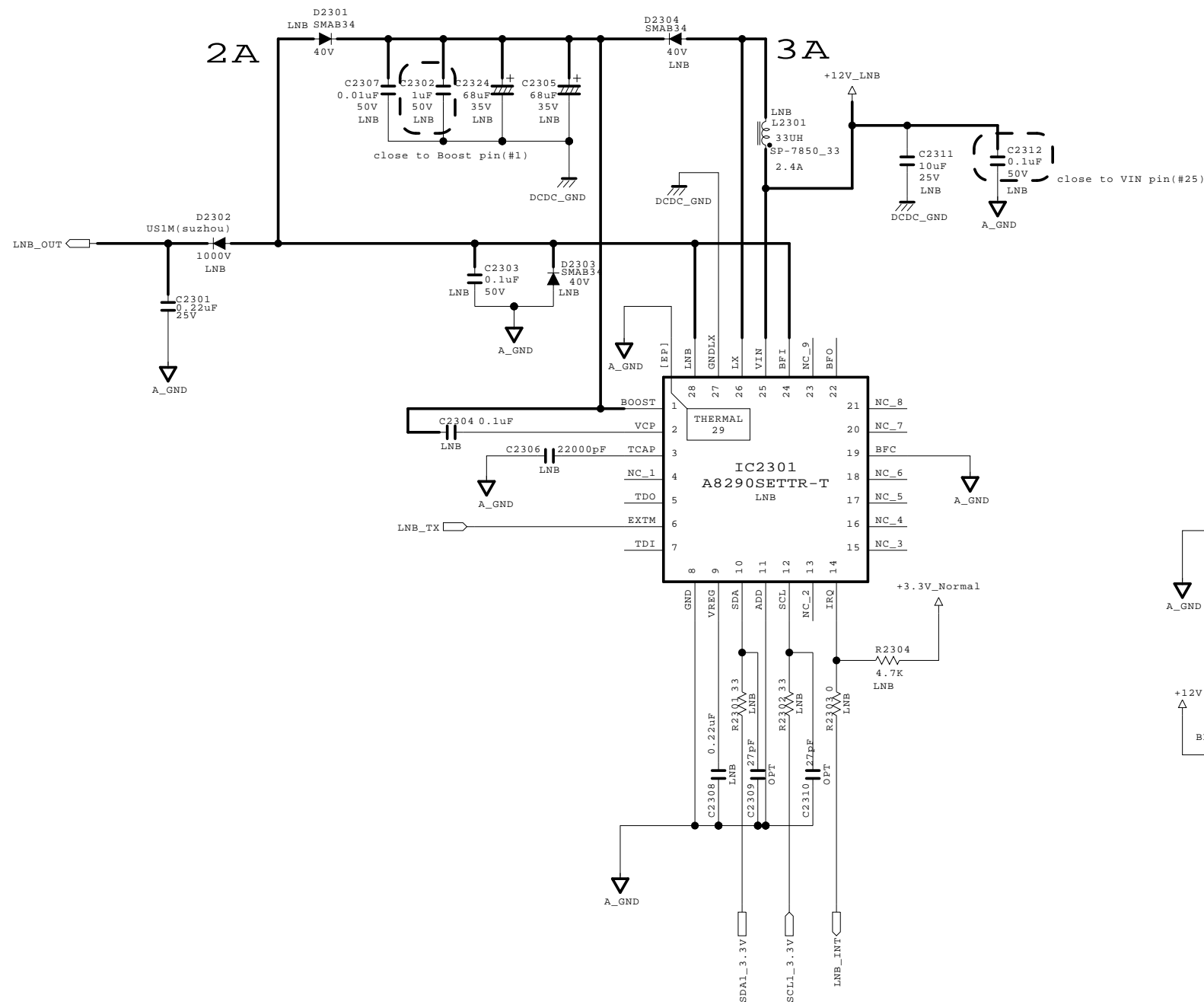

DCDC_GND and A_GND are connected
 DCDC_GND and A_GND are connected in pin#27
 PCB_GND and A_GND are connected

Input trace widths should be sized to conduct at least 3A
 Output trace widths should be sized to conduct at least 2A

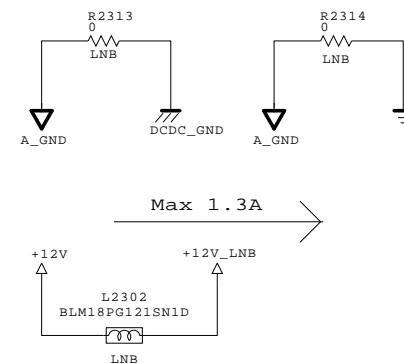

THE SYMBOL MARK OF THIS SCHEMATIC DIAGRAM INCORPORATES SPECIAL FEATURES IMPORTANT FOR PROTECTION FROM X-RADIATION. FILRE AND ELECTRICAL SHOCK HAZARDS, WHEN SERVICING IF IS ESSENTIAL THAT ONLY MANUFACTURES SPECIFIED PARTS BE USED FOR THE CRITICAL COMPONENTS IN THE SYMBOL MARK OF THE SCHEMATIC.

SECRET	LG ELECTRONICS
LGElectronics	

MODEL	BCM35230	DATE	2010.11.02
BLOCK	LNB	SHEET	23 / 57

DUAL COMPONENT	
Q2502, Q2503 Q2504, Q2506 Q2507, Q2508	1ST : OTRIY80001A 2ND : OTR387500AA
Q2501	1ST : EBK61012701, 2ND : EBK58172301
Q2505	1ST : OTRIH80004A, 2ND : EBK61012501, 3RD : OTR102009AM
D2513	1ST : T-BAT54_SUZH0, 2ND : ODS0N00138A

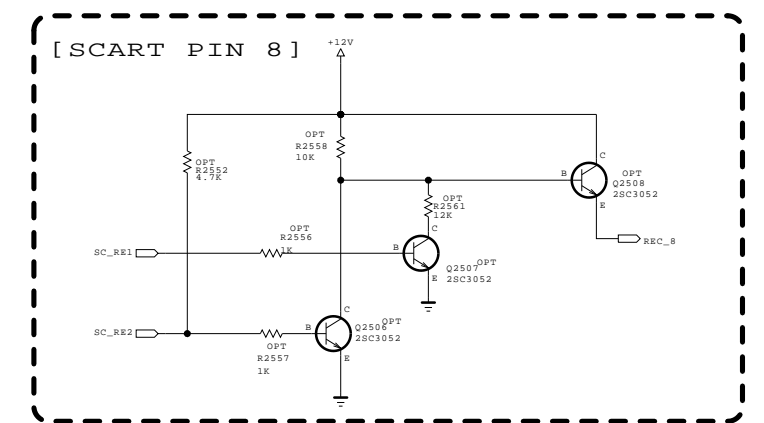
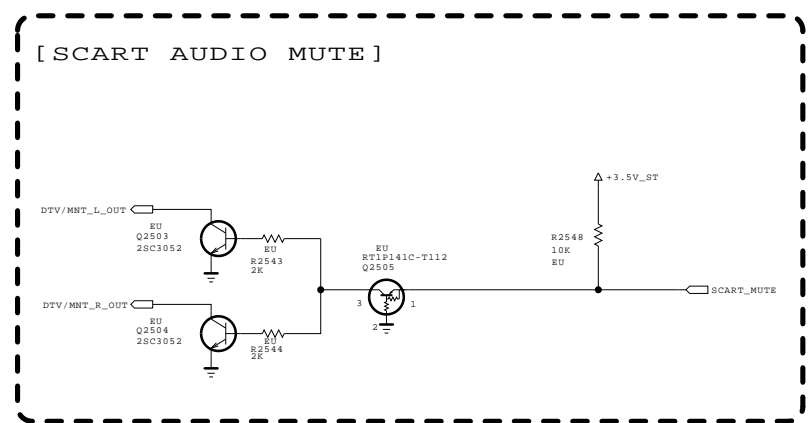
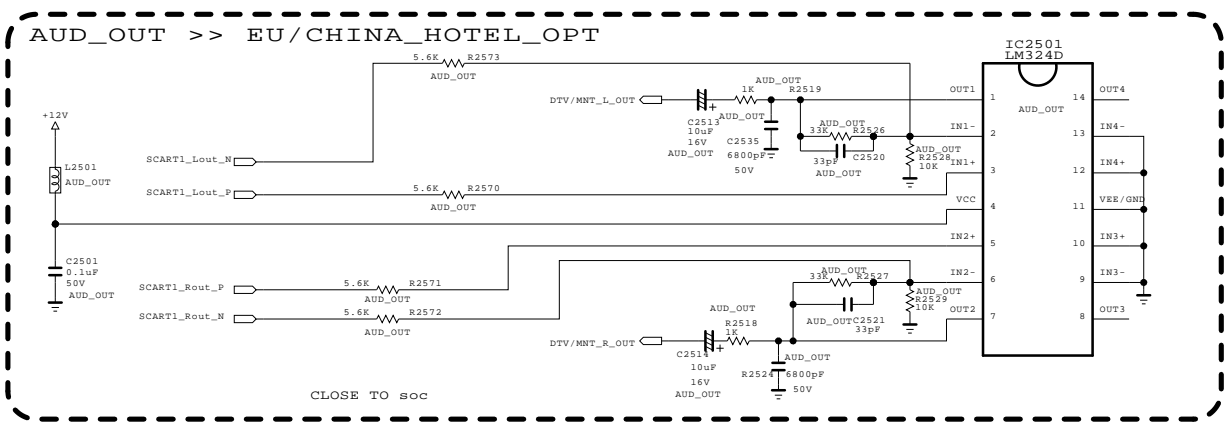
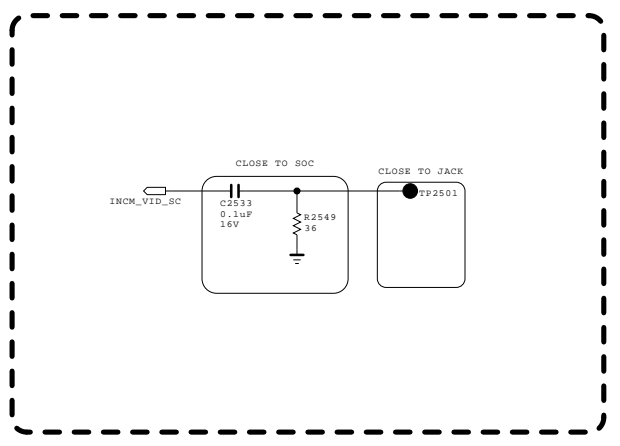
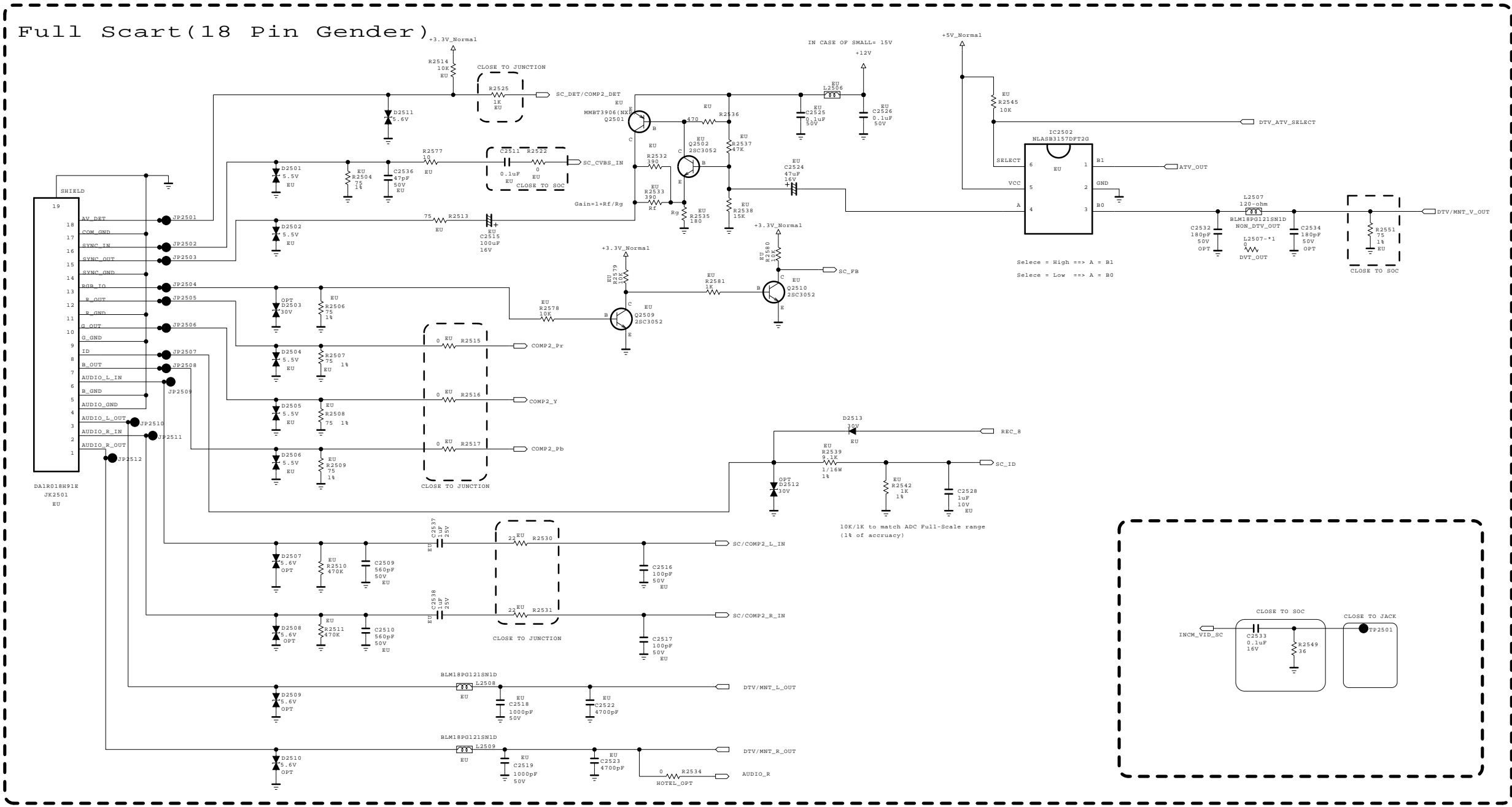

THE SYMBOL MARK OF THIS SCHEMATIC DIAGRAM INCORPORATES SPECIAL FEATURES IMPORTANT FOR PROTECTION FROM X-RADIATION. FILRE AND ELECTRICAL SHOCK HAZARDS, WHEN SERVICING IF IS ESSENTIAL THAT ONLY MANUFACTURES SPECIFIED PARTS BE USED FOR THE CRITICAL COMPONENTS IN THE SYMBOL MARK OF THE SCHEMATIC.



SECRET
LGElectronics

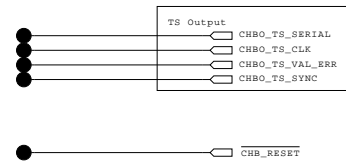

MODEL	BCM35230	DATE	
BLOCK	SCART	SHEET	25

NON CHB



THE  SYMBOL MARK OF THIS SCHEMATIC DIAGRAM INCORPORATES SPECIAL FEATURES IMPORTANT FOR PROTECTION FROM X-RADIATION. FILRE AND ELECTRICAL SHOCK HAZARDS, WHEN SERVICING IF IS ESSENTIAL THAT ONLY MANUFACTURES SPECIFIED PARTS BE USED FOR THE CRITICAL COMPONENTS IN THE  SYMBOL MARK OF THE SCHEMATIC.

SECRET
LGElectronics



MODEL	BCM35230	DATE	
BLOCK	NON CHB	SHEET	28 / 50

China Hotel Option

DUAL COMPONENT	
Q2901	1ST : EBK61012601 2ND : 0TRDI80002A

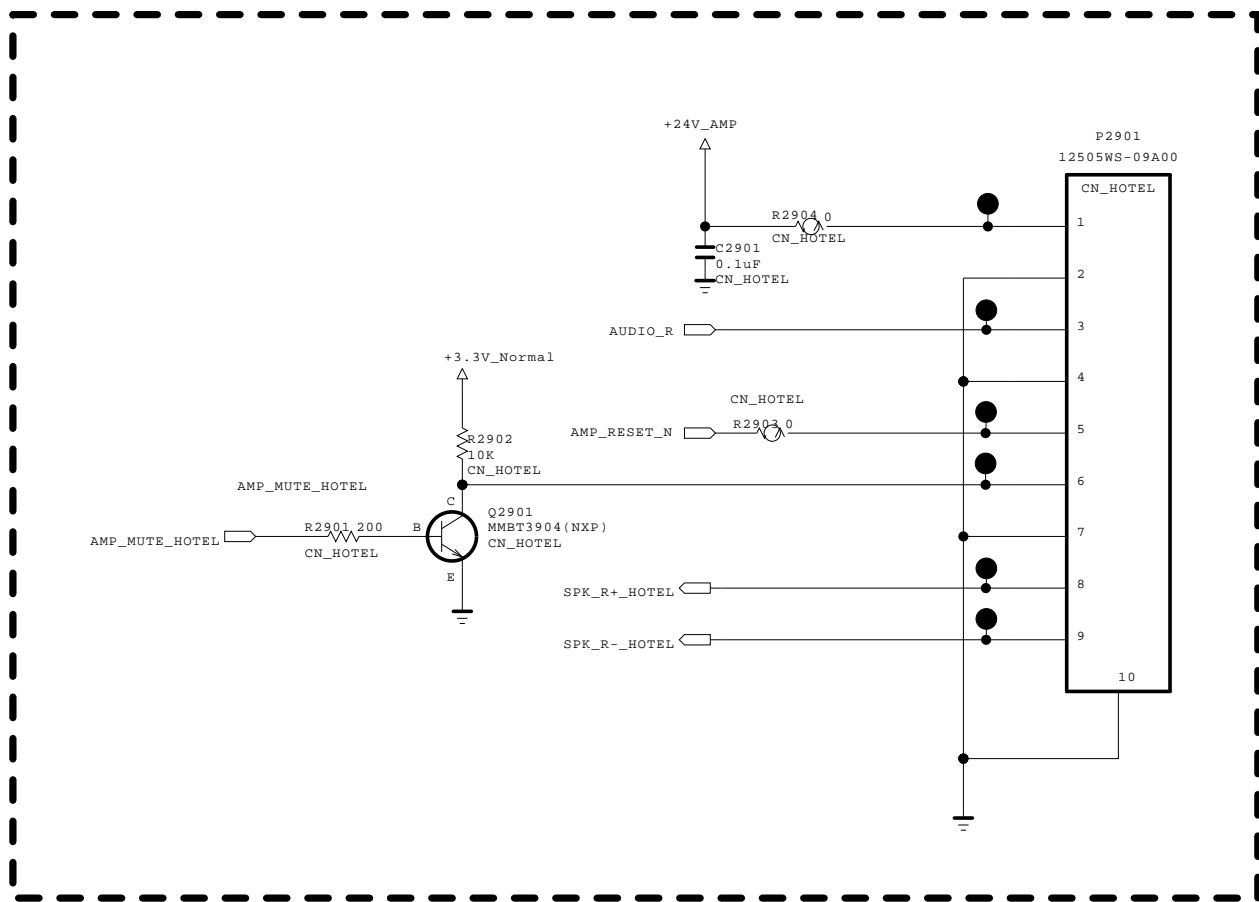

THE SYMBOL MARK OF THIS SCHEMATIC DIAGRAM INCORPORATES SPECIAL FEATURES IMPORTANT FOR PROTECTION FROM X-RADIATION. FILRE AND ELECTRICAL SHOCK HAZARDS, WHEN SERVICING IF IS ESSENTIAL THAT ONLY MANUFATURES SPECIFIED PARTS BE USED FOR THE CRITICAL COMPONENTS IN THE SYMBOL MARK OF THE SCHEMATIC.

SECRET	LG ELECTRONICS
LGElectronics	

MODEL	BCM35230	DATE	
BLOCK	CHINA HOTEL	SHEET	29 /

LVDS

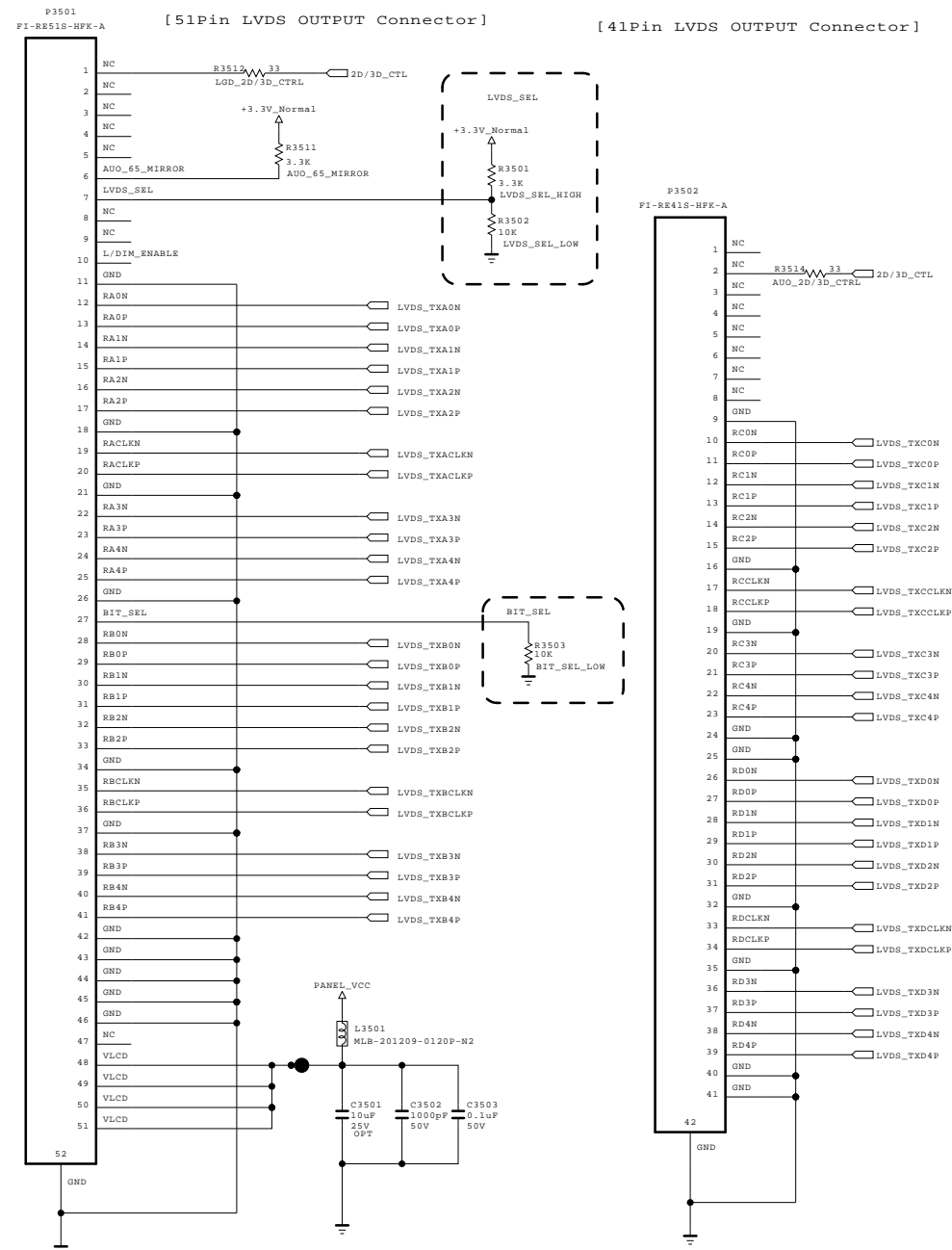

LOCAL DIMMING

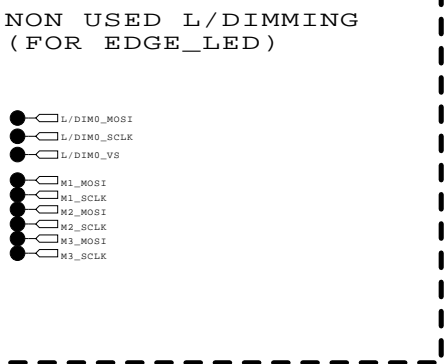
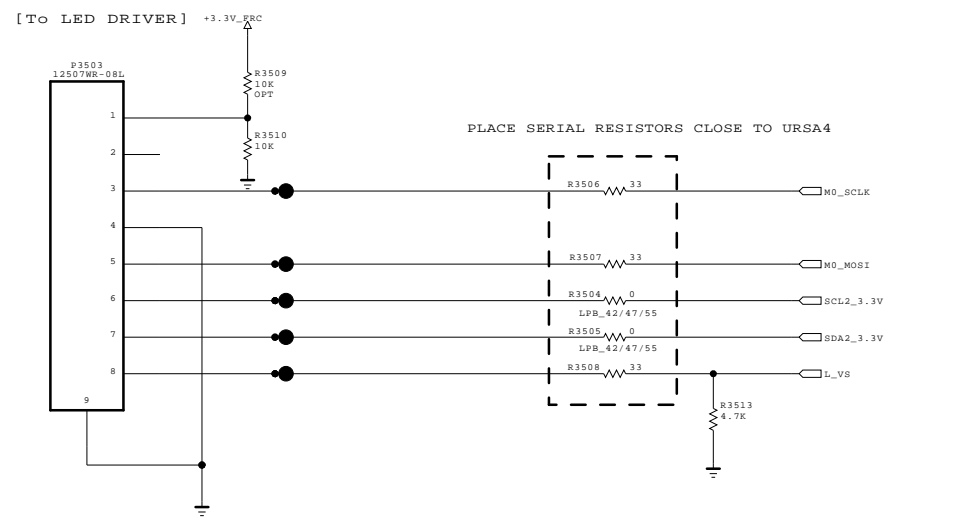

THE SYMBOL MARK OF THIS SCHEMATIC DIAGRAM INCORPORATES SPECIAL FEATURES IMPORTANT FOR PROTECTION FROM X-RADIATION. FILRE AND ELECTRICAL SHOCK HAZARDS, WHEN SERVICING IF IS ESSENTIAL THAT ONLY MANUFACTURES SPECIFIED PARTS BE USED FOR THE CRITICAL COMPONENTS IN THE SYMBOL MARK OF THE SCHEMATIC.

SECRET
LGElectronics



MODEL	BCM35230	DATE	2010. 10. 20
BLOCK	Interface block	SHEET	35 / 58

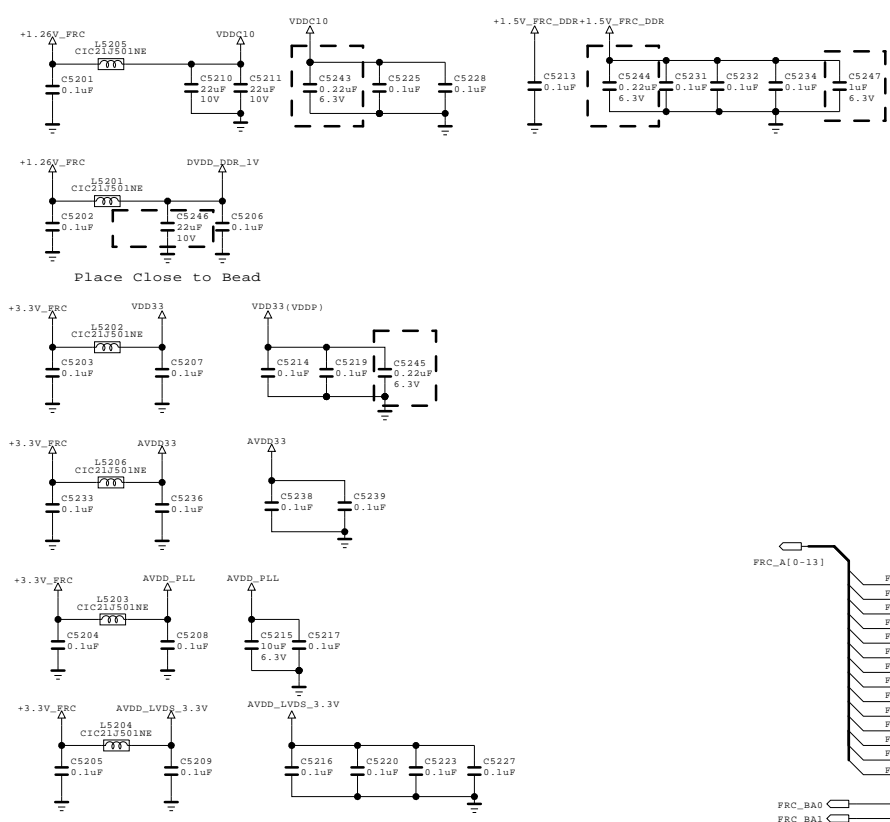

GPIO1 : HI => B8/94 | LOW => B4/98 |
 CHIP_CONF : {GPIO8, PWM1, PWM0}
 CHIP_CONF = 3'd5 : boot from internal SRAM
 CHIP_CONF = 3'd6 : boot from **MACROMI**
 CHIP_CONF = 3'd7 : boot from **SPI Flash**

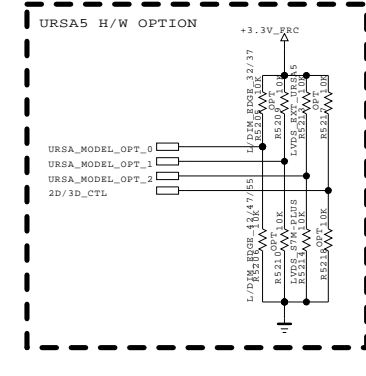
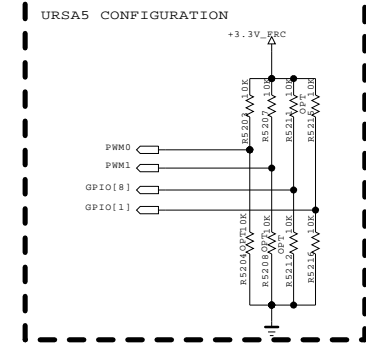

MODEL OPTION

PIN NAME	PIN NO.	HIGH	LOW
MODEL_OPT_0	D10	L/DIM_10BLOCK	L/DIM_16BLOCK
MODEL_OPT_1	D11	RESERVED	RESERVED
MODEL_OPT_2	D12	LVDS_EXT_URSA5	LVDS_07M_PLUS
MODEL_OPT_3	D13	RESERVED	RESERVED

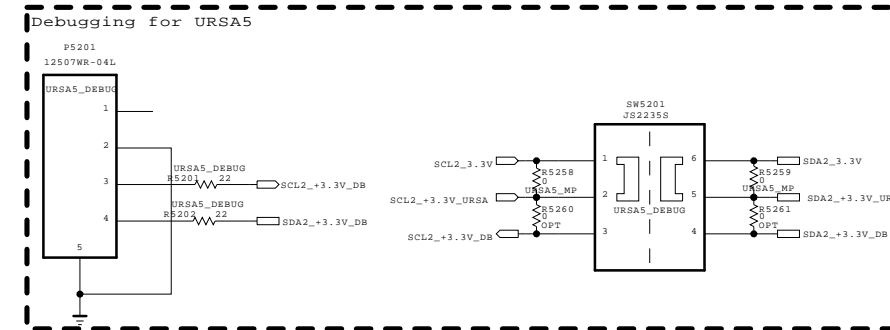

THE SYMBOL MARK OF THIS SCHEMATIC DIAGRAM INCORPORATES SPECIAL FEATURES IMPORTANT FOR PROTECTION FROM X-RADIATION. FILRE AND ELECTRICAL SHOCK HAZARDS, WHEN SERVICING IF IS ESSENTIAL THAT ONLY MANUFACTURES SPECIFIED PARTS BE USED FOR THE CRITICAL COMPONENTS IN THE SYMBOL MARK OF THE SCHEMATIC.

SECRET
 LG ELECTRONICS

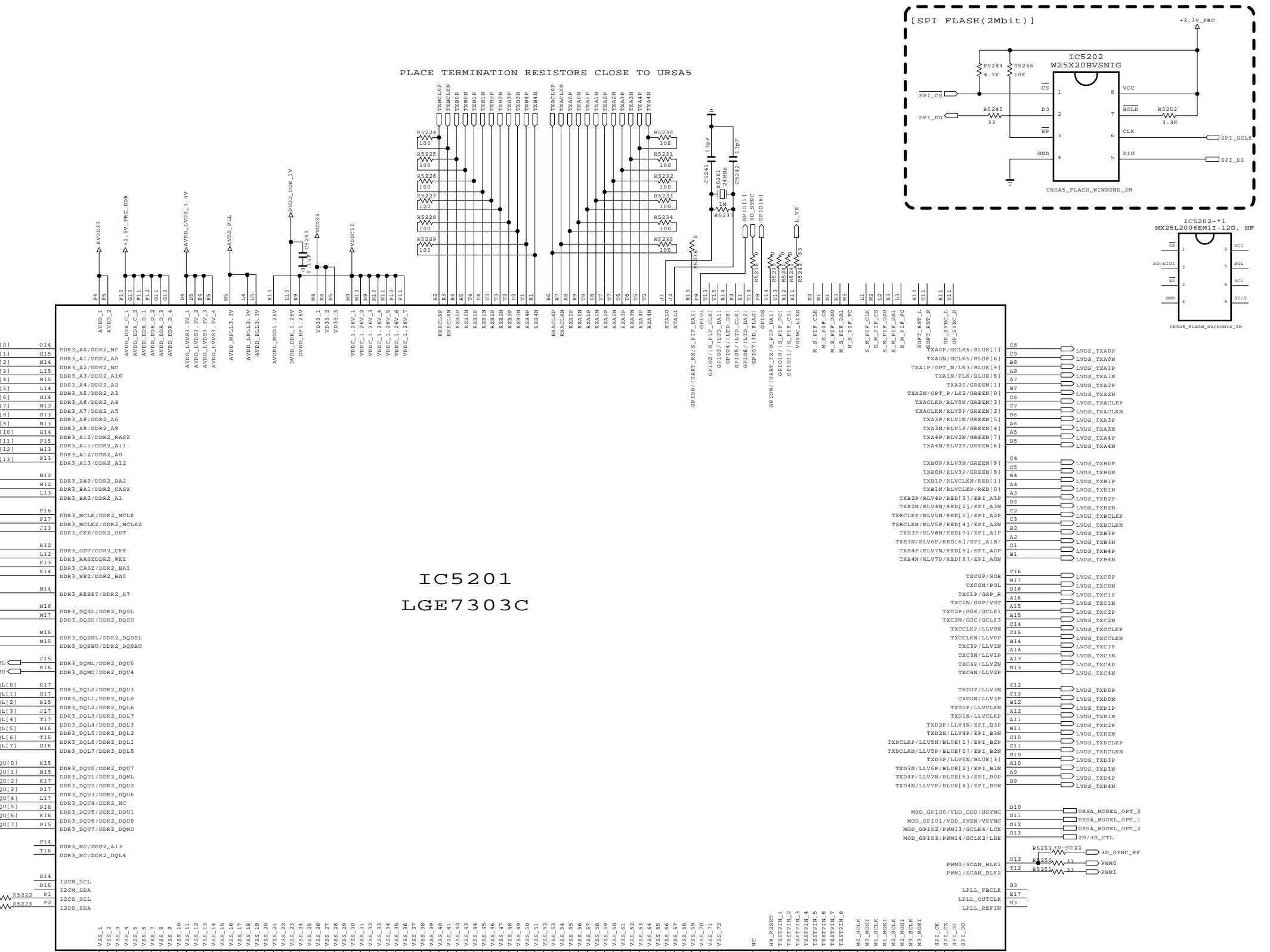

IC5201
 LGE7303C

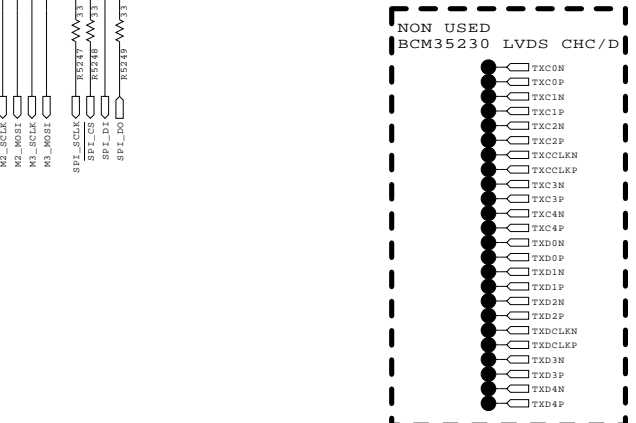

MODEL	MStar URSA5	DATE	2010. 08.18
BLOCK	FRC block	SHEET	52 / 55

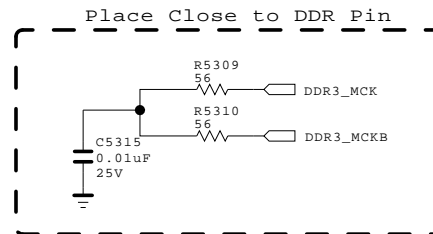
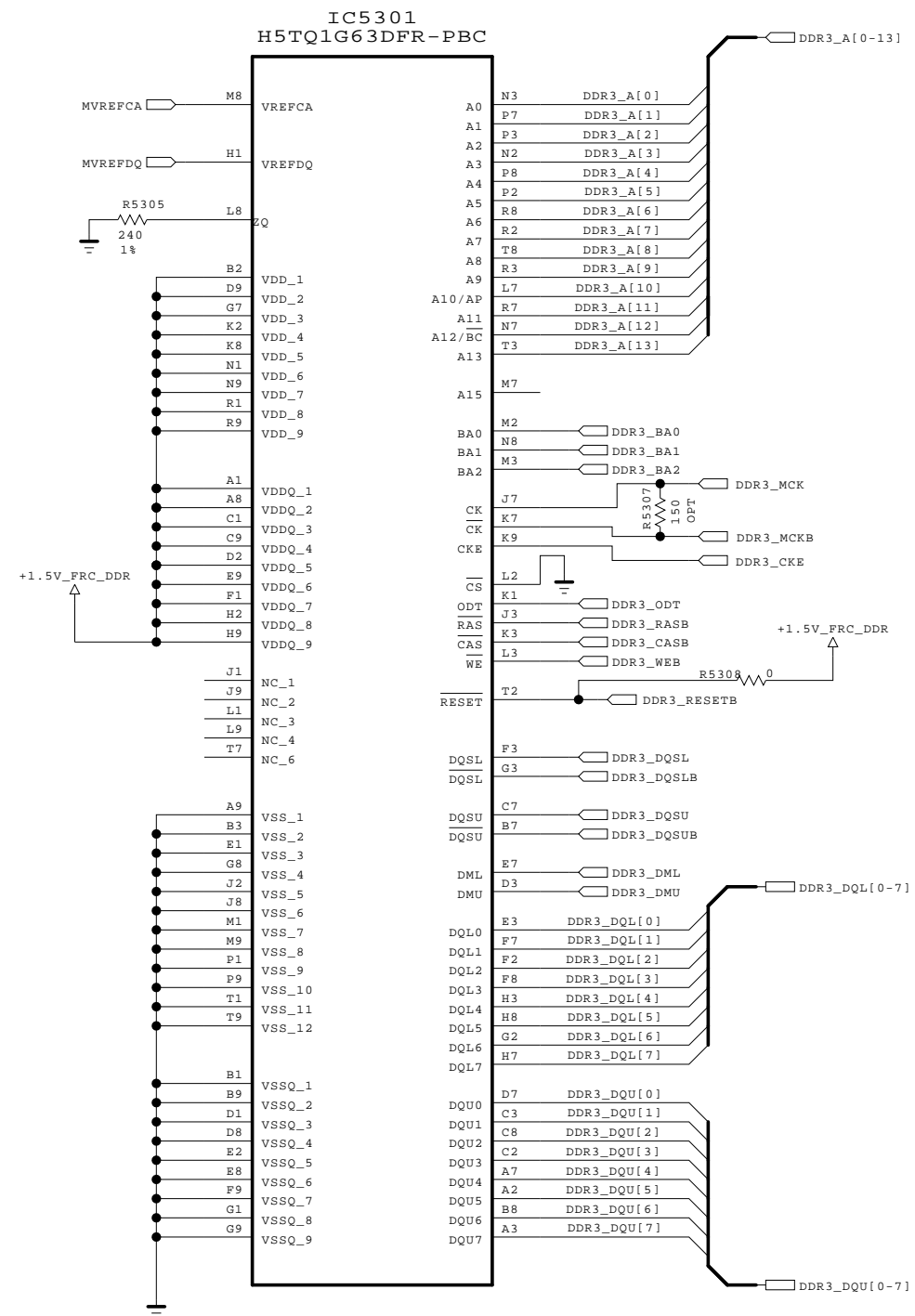
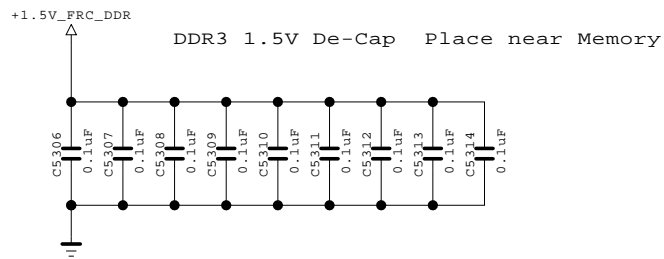
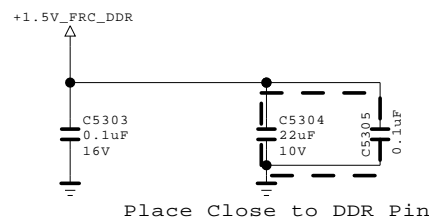
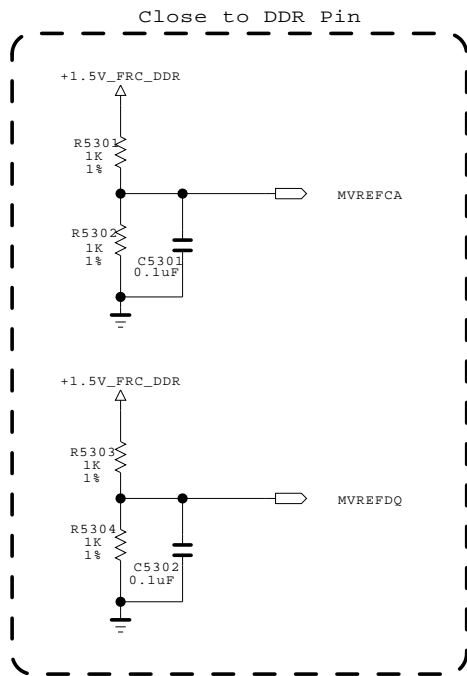

Place the serail damping resistors in the middle of DRAM pattern

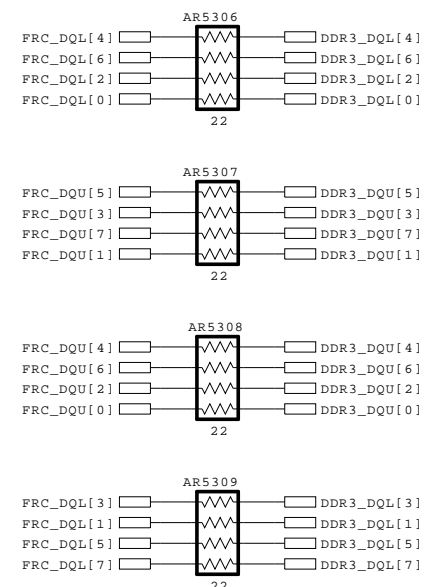
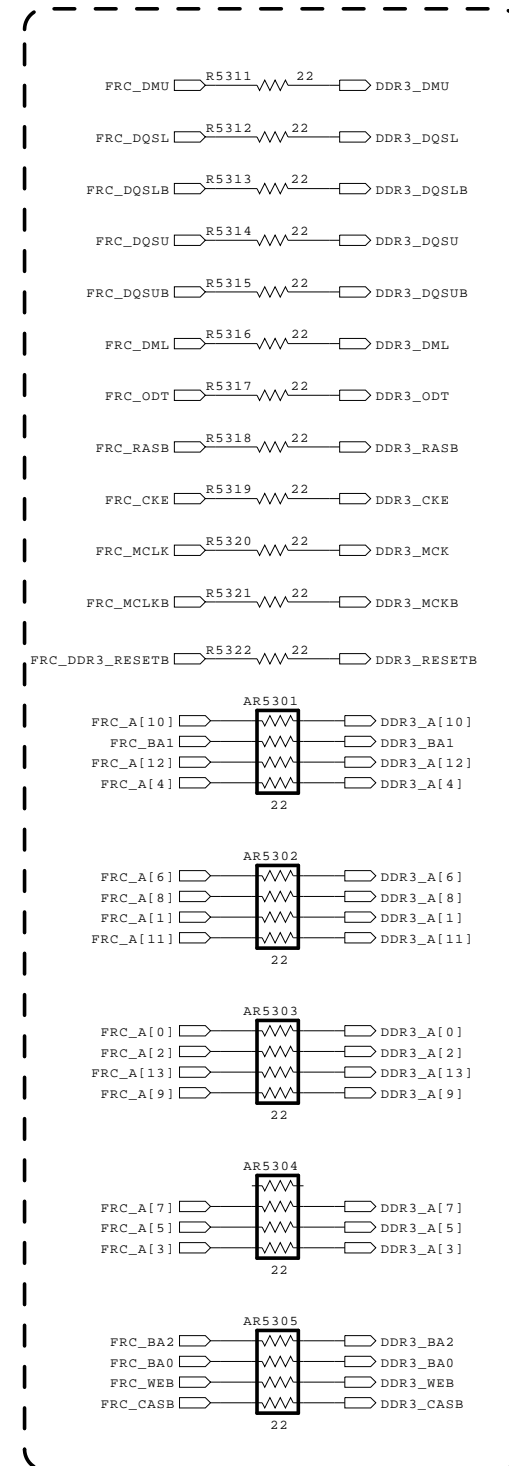

THE SYMBOL MARK OF THIS SCHEMATIC DIAGRAM INCORPORATES SPECIAL FEATURES IMPORTANT FOR PROTECTION FROM X-RADIATION. FILRE AND ELECTRICAL SHOCK HAZARDS, WHEN SERVICING IF IS ESSENTIAL THAT ONLY MANUFACTURES SPECIFIED PARTS BE USED FOR THE CRITICAL COMPONENTS IN THE SYMBOL MARK OF THE SCHEMATIC.

SECRET

LG Electronics

MODEL	MStar URSA5	DATE	2010. 08.18
BLOCK	DDR3 4Mbit	SHEET	53 / 55

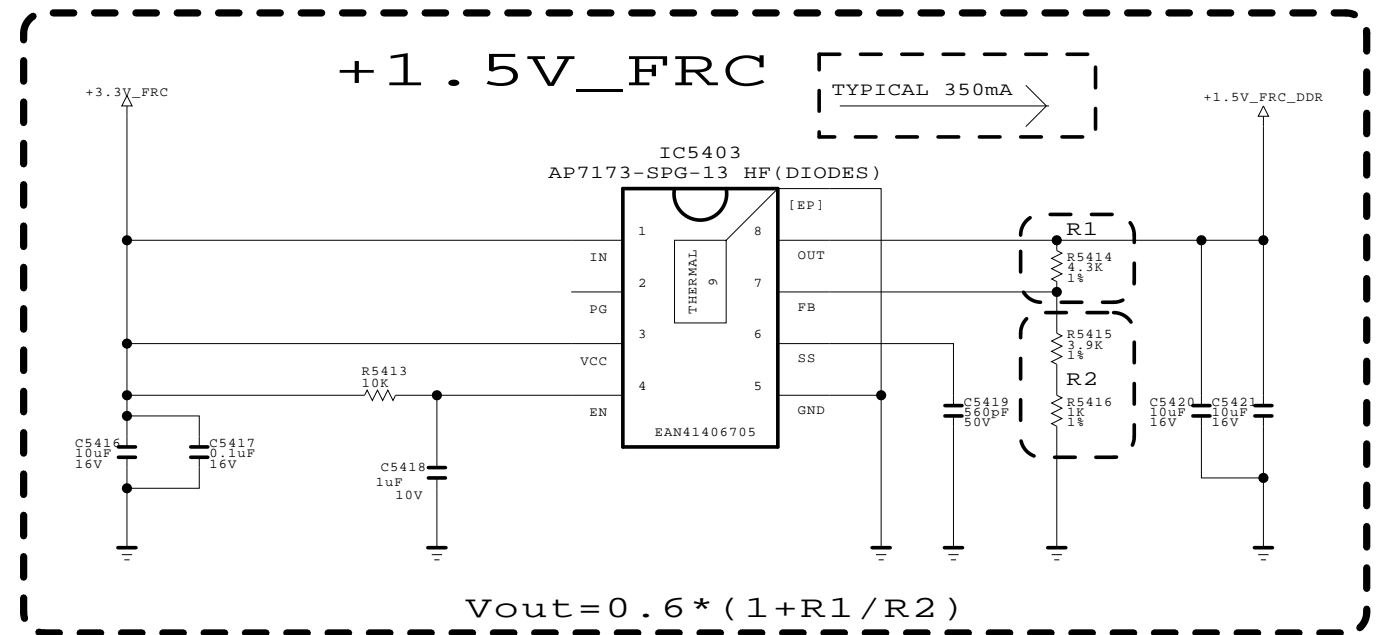
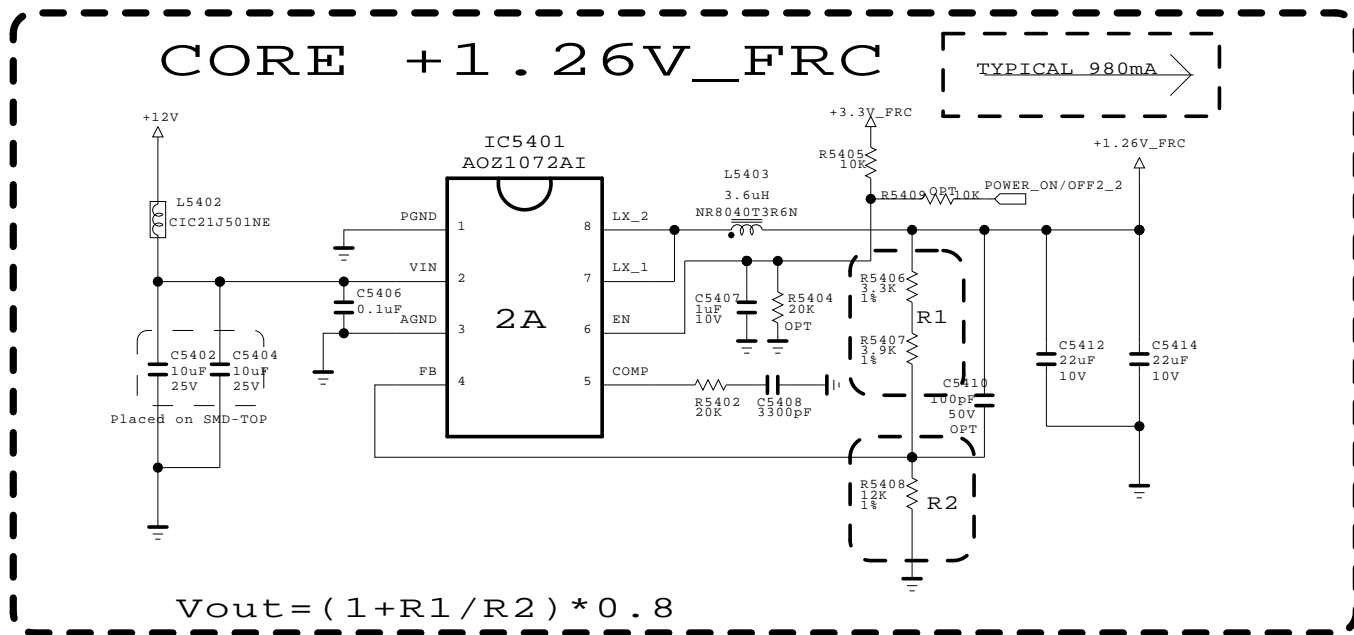

+1.5V of DDR&URSA5 uses same power line

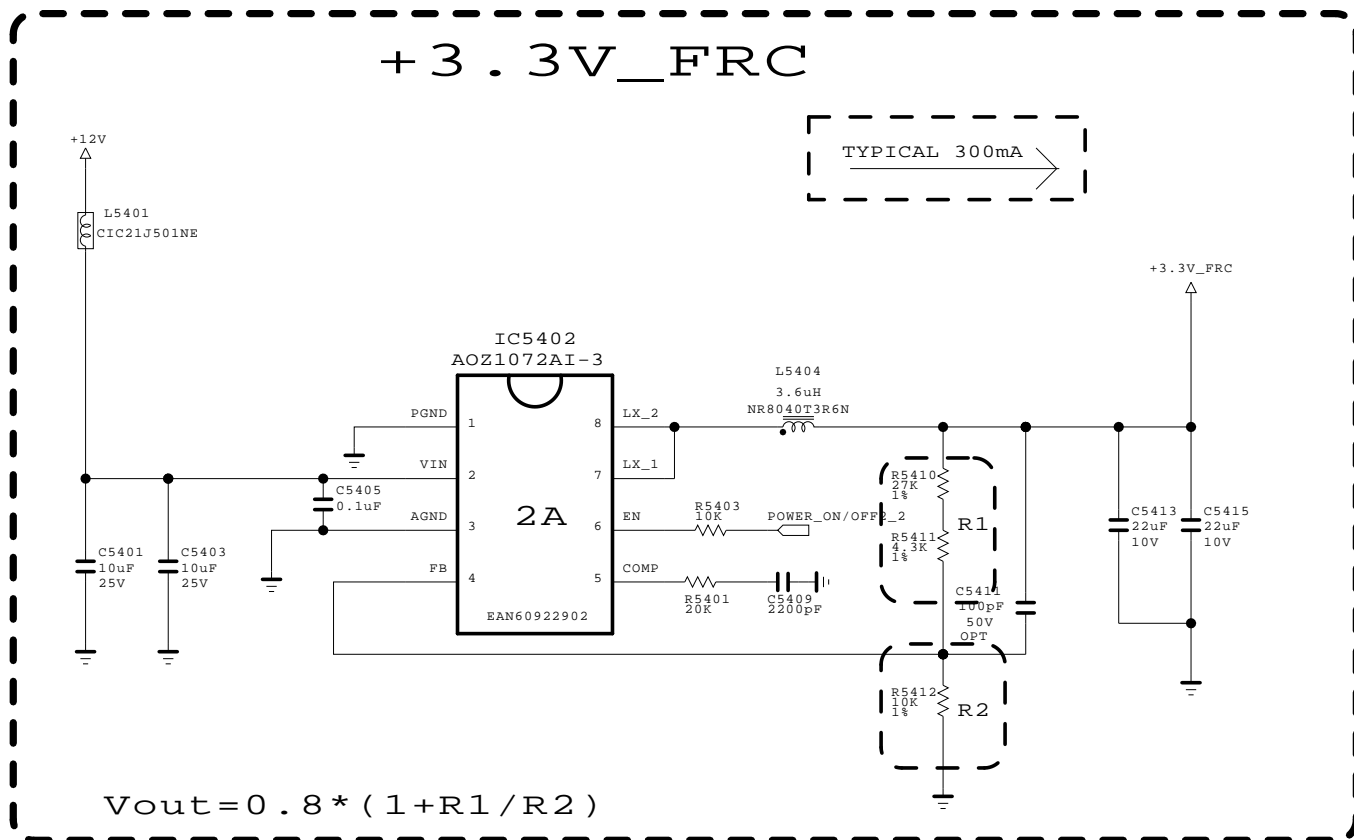

THE ⚠ SYMBOL MARK OF THIS SCHEMATIC DIAGRAM INCORPORATES SPECIAL FEATURES IMPORTANT FOR PROTECTION FROM X-RADIATION. FILRE AND ELECTRICAL SHOCK HAZARDS, WHEN SERVICING IF IS ESSENTIAL THAT ONLY MANUFACTURES SPECIFIED PARTS BE USED FOR THE CRITICAL COMPONENTS IN THE ⚠ SYMBOL MARK OF THE SCHEMATIC.

SECRET	LG ELECTRONICS
LG Electronics	

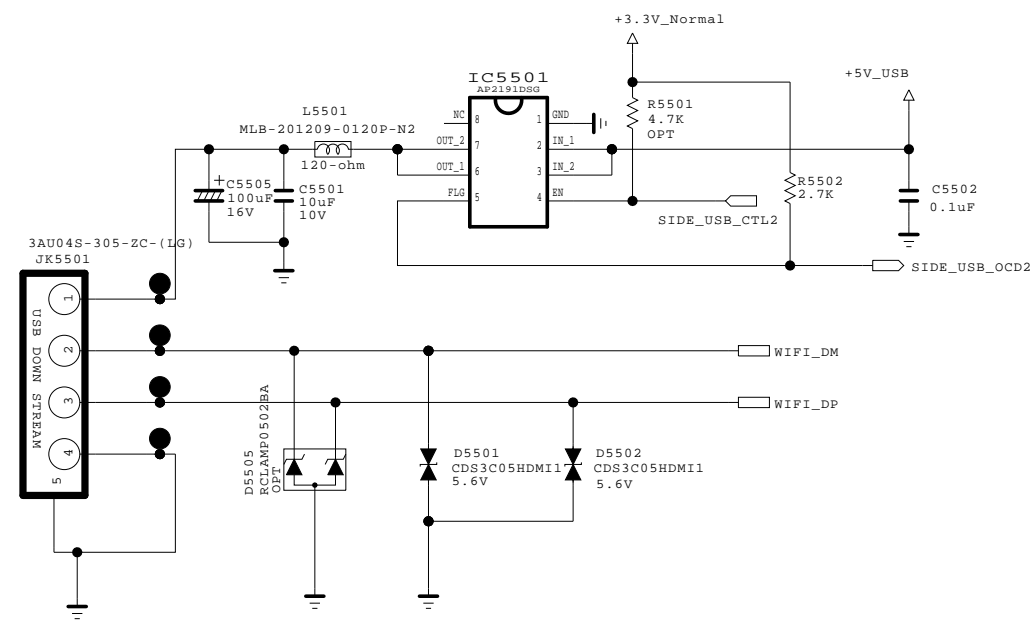

MODEL	MStar URSA5	DATE	2010. 08.18
BLOCK	URSA5 Power Block	SHEET	54 / 55

USB / DVR Ready

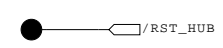
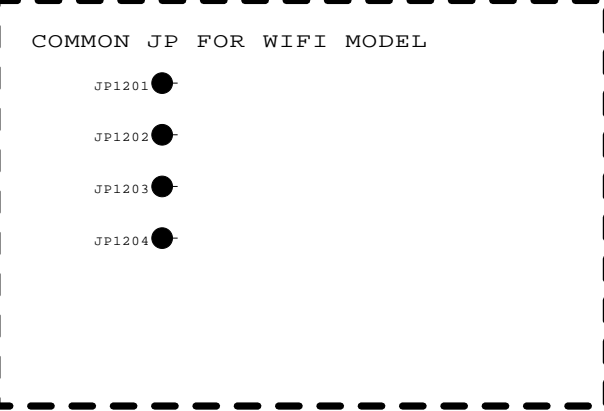
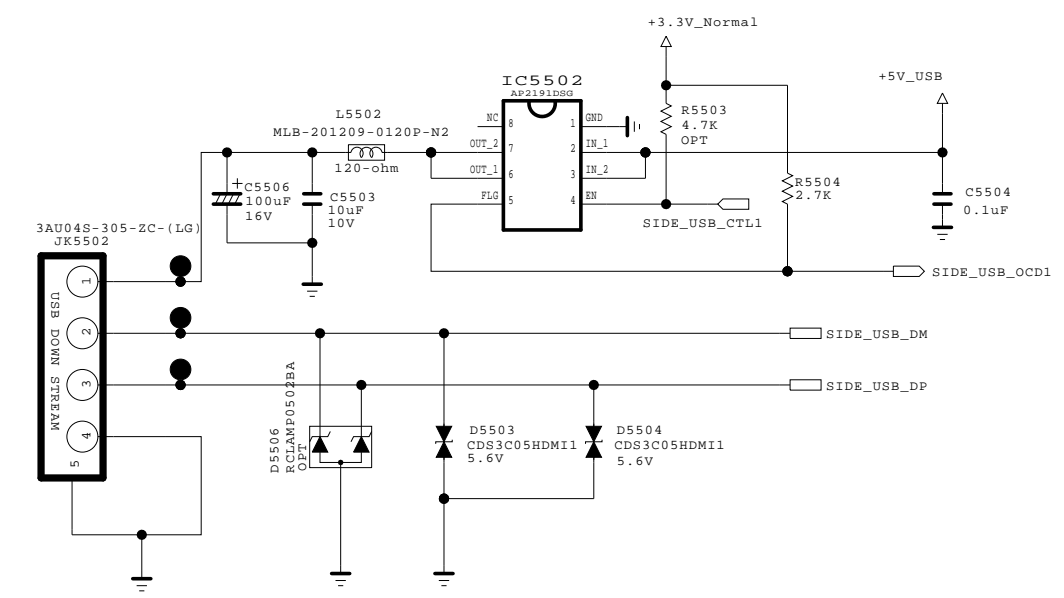

USB



THE  SYMBOL MARK OF THIS SCHEMATIC DIAGRAM INCORPORATES SPECIAL FEATURES IMPORTANT FOR PROTECTION FROM X-RADIATION. FILRE AND ELECTRICAL SHOCK HAZARDS, WHEN SERVICING IF IS ESSENTIAL THAT ONLY MANUFACTURES SPECIFIED PARTS BE USED FOR THE CRITICAL COMPONENTS IN THE  SYMBOL MARK OF THE SCHEMATIC.

SECRET
LGElectronics

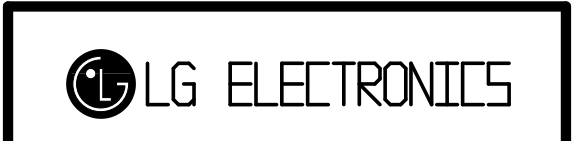

MODEL	BCM35230	DATE	2010. 10. 20
BLOCK	USB (NON WIFI)	SHEET	55 /

SMD GASKET

SMD GASKET 4.5T

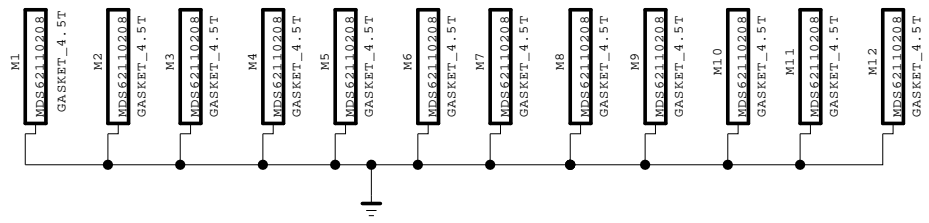

SMD GASKET 5.0T

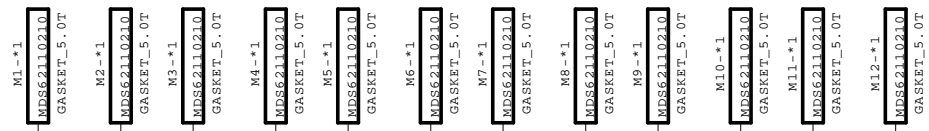

SMD GASKET 5.5T

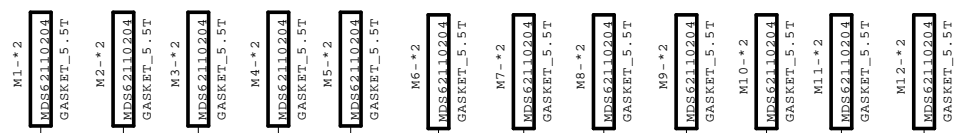

SMD GASKET 6.5T

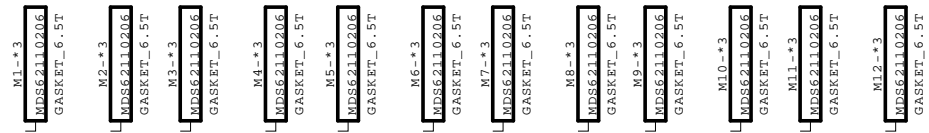

SMD GASKET 7.5T



SMD GASKET 8.5T



SMD GASKET 9.5T

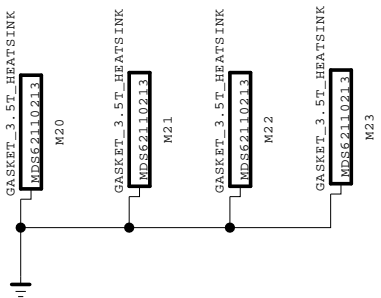
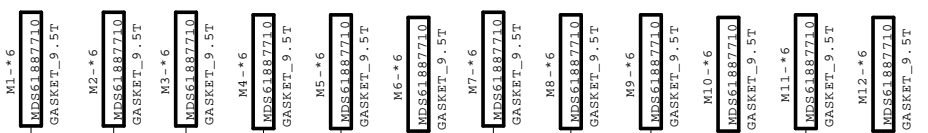

THE SYMBOL MARK OF THIS SCHEMATIC DIAGRAM INCORPORATES SPECIAL FEATURES IMPORTANT FOR PROTECTION FROM X-RADIATION. FILRE AND ELECTRICAL SHOCK HAZARDS, WHEN SERVICING IF IS ESSENTIAL THAT ONLY MANUFACTURES SPECIFIED PARTS BE USED FOR THE CRITICAL COMPONENTS IN THE SYMBOL MARK OF THE SCHEMATIC.

SECRET	LG ELECTRONICS
LGElectronics	

MODEL	BCM35230	DATE	2010. 09. 18
BLOCK	SMD GASKET	SHEET	70

FROM LIPS & POWER B/D

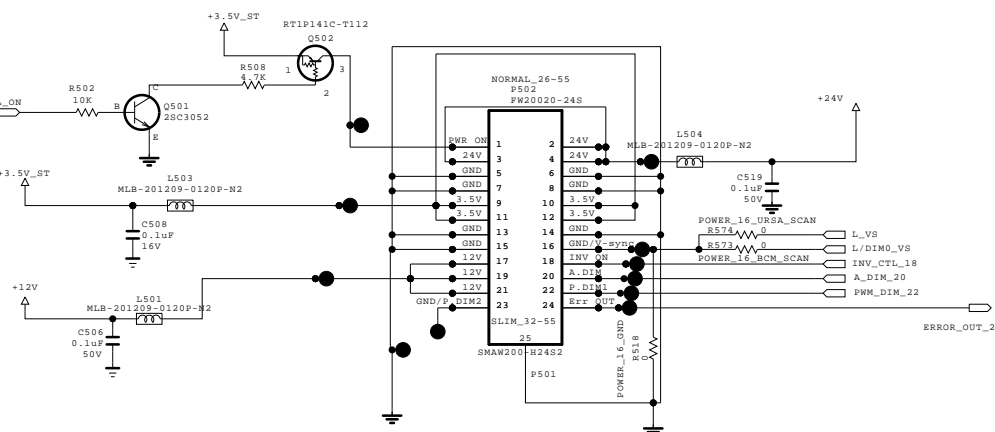

#16/#20/#23
LD - GND OR USE
LE(N.L.D.) - OPEN
LE(L.D.) - USE

DUAL COMPONENT		
Q501,Q504, Q505,Q506	1ST : 0TRIY80001A	2ND : 0TR387500AA
Q502	1ST : 0TRIY80004A,	2ND : EBK61012501, 3RD : 0TR102009AM
Q507	1ST : EBK60752501,	2ND : EBK61011501
IC502,IC503	1ST : EAN61151001,	2ND : EAN60670101

OS Module OPT

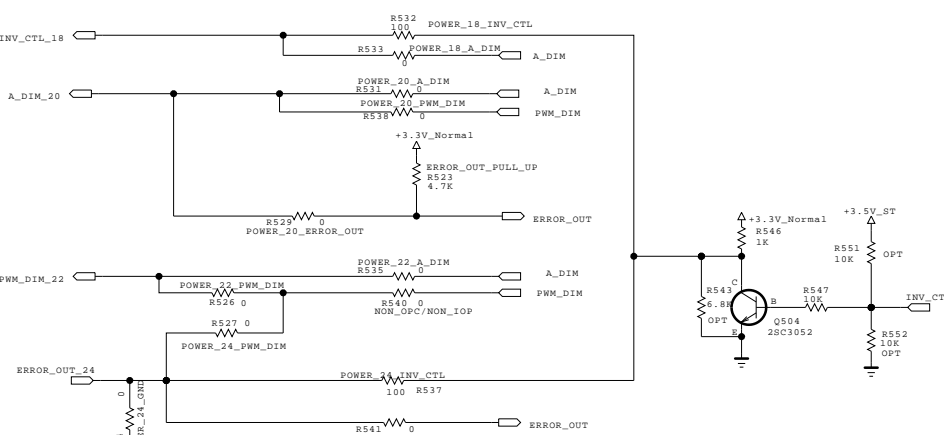

<OS MODULE PIN MAP>

PIN No	LGD	CMO (09)	AUO	SHARP
18	INV_ON	A-DIM	INV_ON	INV_ON
20	V4:VBR-A V5:NC	NC	Err_out	Err_out
22	PWM_DIM	PWM_DIM	A-DIM	PWM_DIM
24	Err_out LED:GND	INV_ON	PWM_DIM	GND

CHECK PWR/MODULE PIN MAP

PANEL_POWER

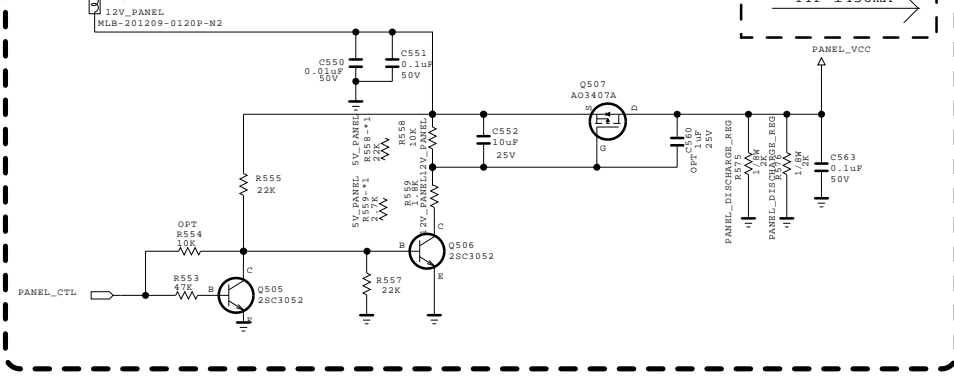

+1.5V_DDR

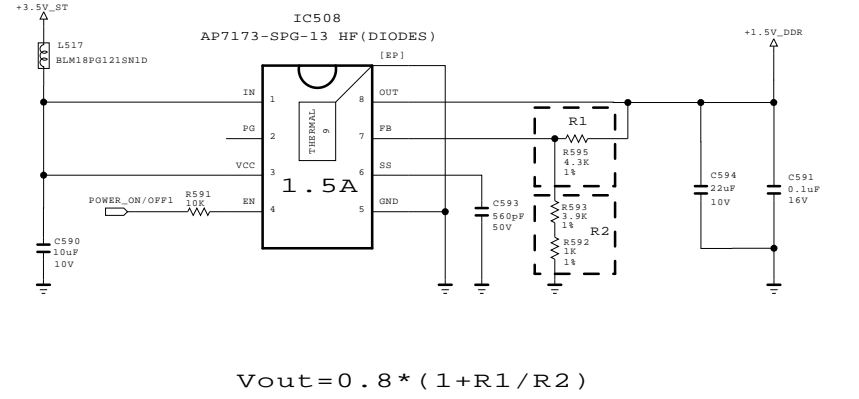

$V_{out} = 0.8 * (1 + R1/R2)$

Power_DET

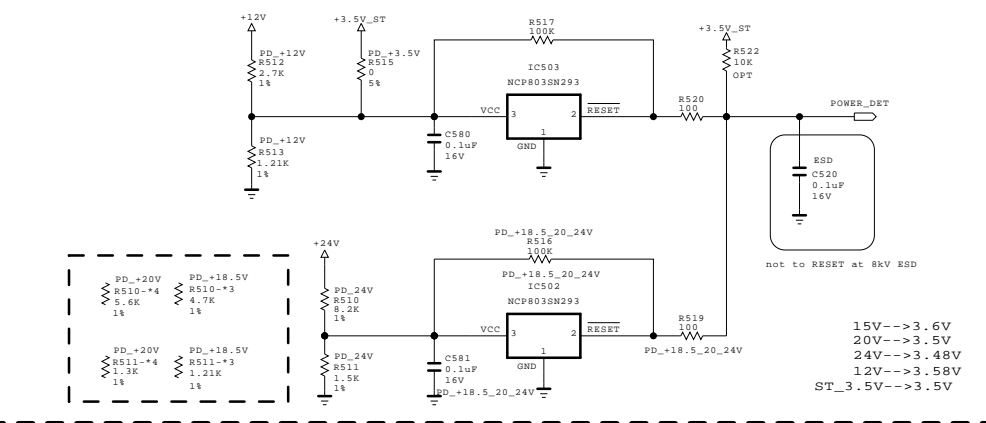

+5V_Normal

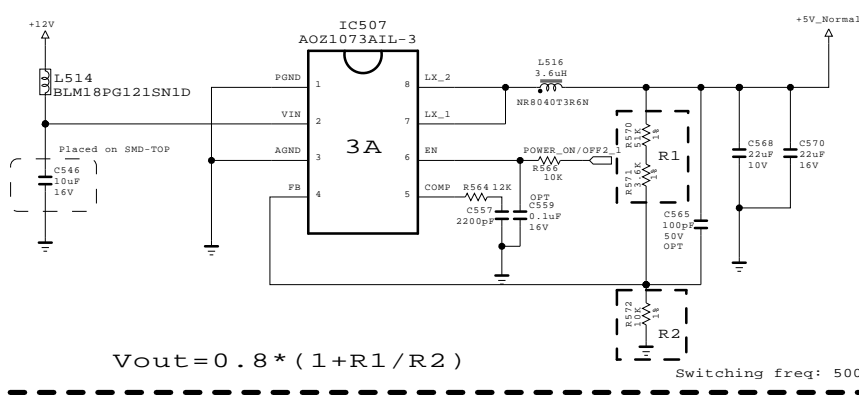

$V_{out} = 0.8 * (1 + R1/R2)$

Switching freq: 500K

+0.9V_CORE_BCM35230

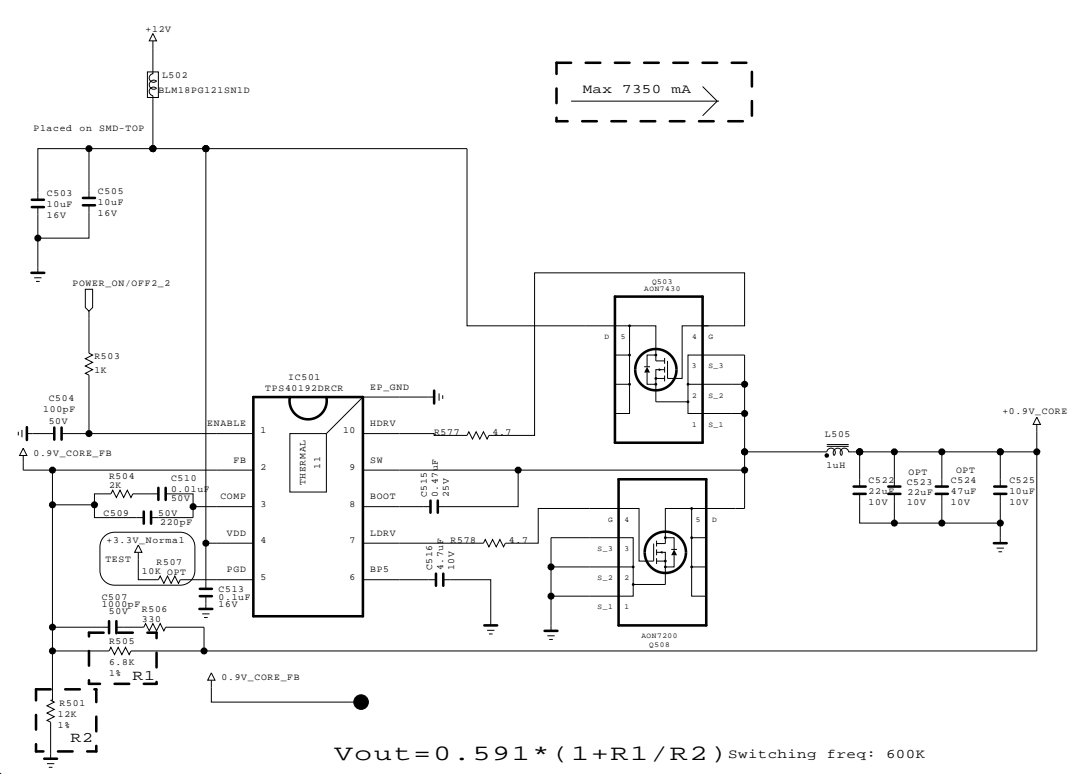

$V_{out} = 0.591 * (1 + R1/R2)$ Switching freq: 600K

+3.3V_NORMAL

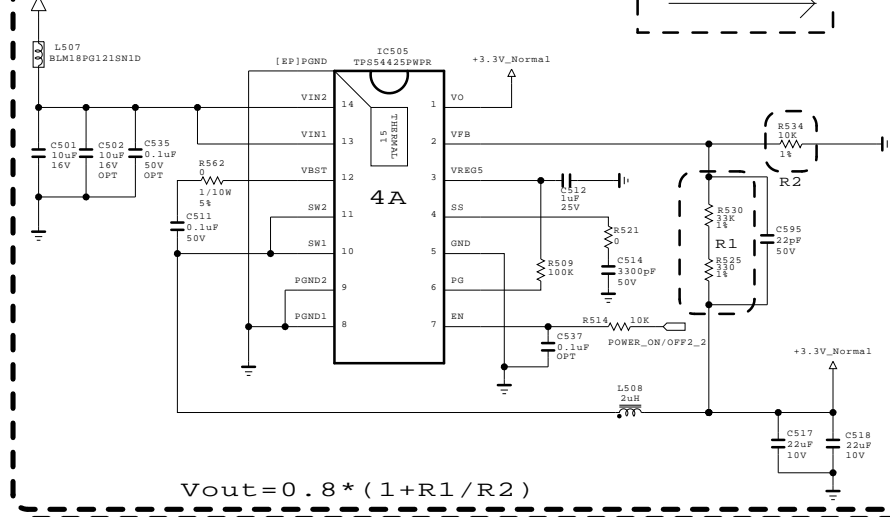

$V_{out} = 0.8 * (1 + R1/R2)$

+2.5V_BCM35230

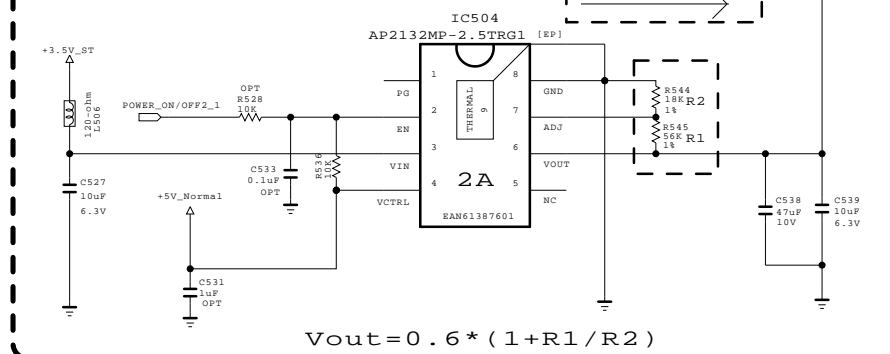

$V_{out} = 0.6 * (1 + R1/R2)$

+5V_USB+WIFI

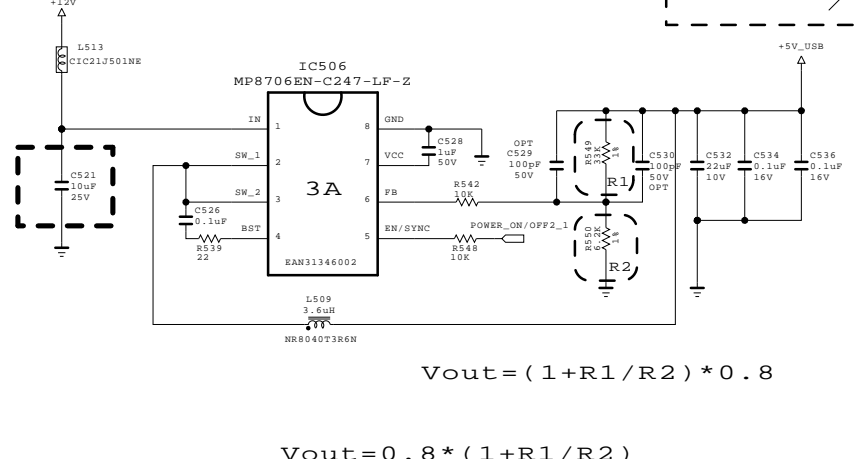

$V_{out} = (1 + R1/R2) * 0.8$

$V_{out} = 0.8 * (1 + R1/R2)$

THE Δ SYMBOL MARK OF THIS SCHEMATIC DIAGRAM INCORPORATES SPECIAL FEATURES IMPORTANT FOR PROTECTION FROM X-RADIATION. FILRE AND ELECTRICAL SHOCK HAZARDS, WHEN SERVICING IF IS ESSENTIAL THAT ONLY MANUFACTURERS SPECIFIED PARTS BE USED FOR THE CRITICAL COMPONENTS IN THE Δ SYMBOL MARK OF THE SCHEMATIC.

SECRET
LGElectronics



MODEL	BCM35230	DATE	
BLOCK	POWER	SHEET	5 / 58



LCD TV Repair Guide

`11 years New Models

< Applicable Model >

XXLW650W/S/G-ZC

XXLW570S/G

XXLW550T/W

T : UK T2/C

W : Nordic T2/C

S : Satellite

G : MHP

LD12C Main PCB for Broadband

XXLW5500/T/W/S-ZA
 XXLW650W/G/S-ZA
 XXLW570G/S-ZA

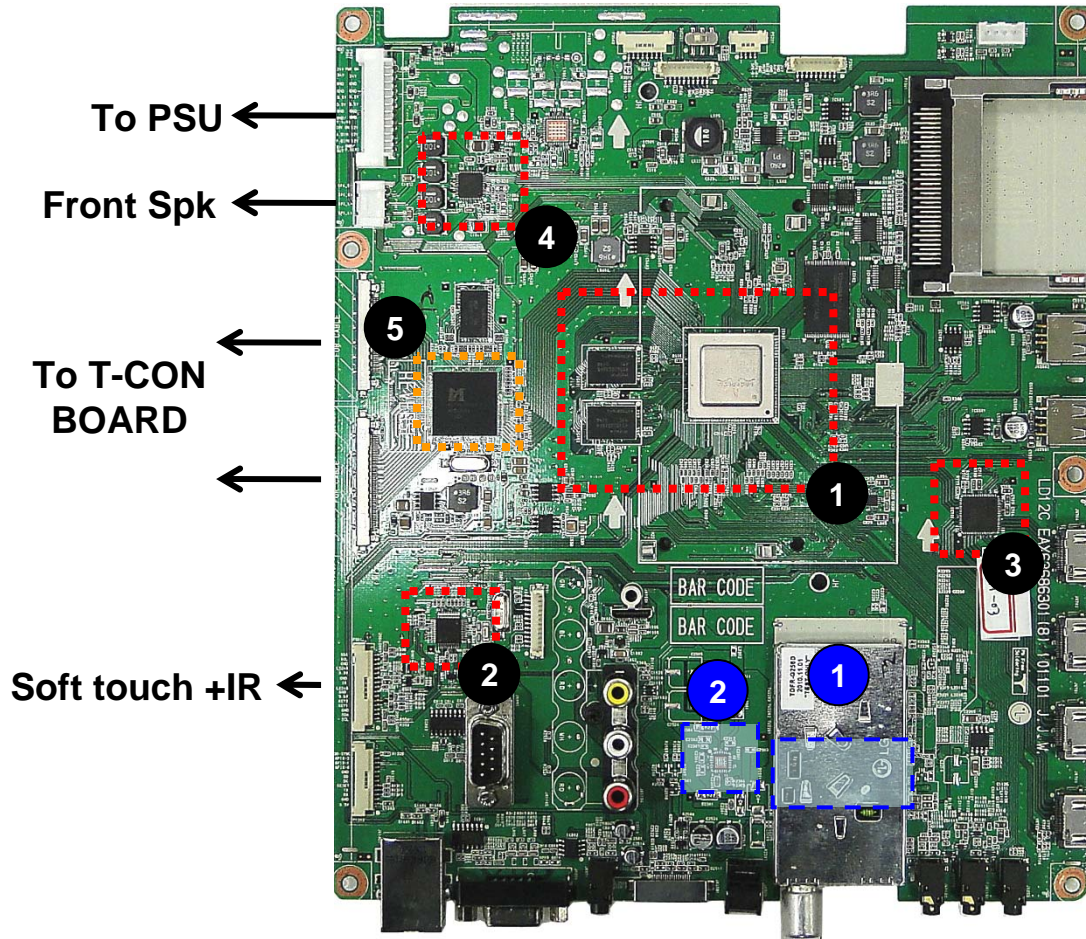

Main Board without T-con b'd

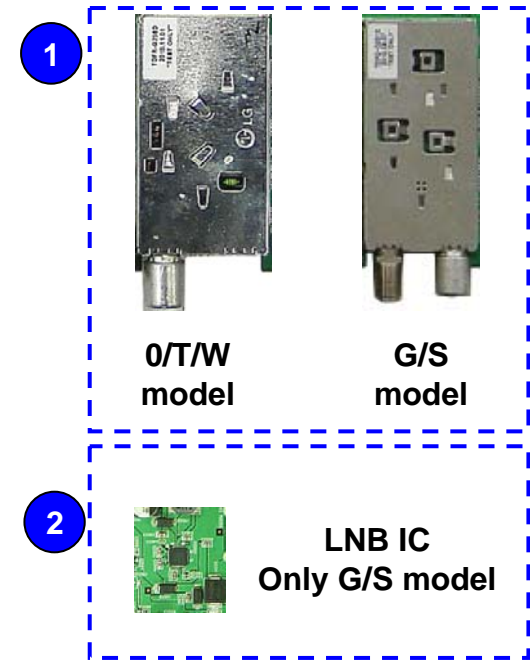

- 1** Main processor, DDR Memory
Flash Memory
- 2** Micom for Key/IR sensing
- 3** HDMI switch (4:1)
- 4** Audio AMP (10W+10W)
- 5** URSA5 External FRC

LD12E Main PCB for Broadband

Main Board without T-con b'd

XXLV5500/T/W/G-ZA
XXLV570G/S-ZA

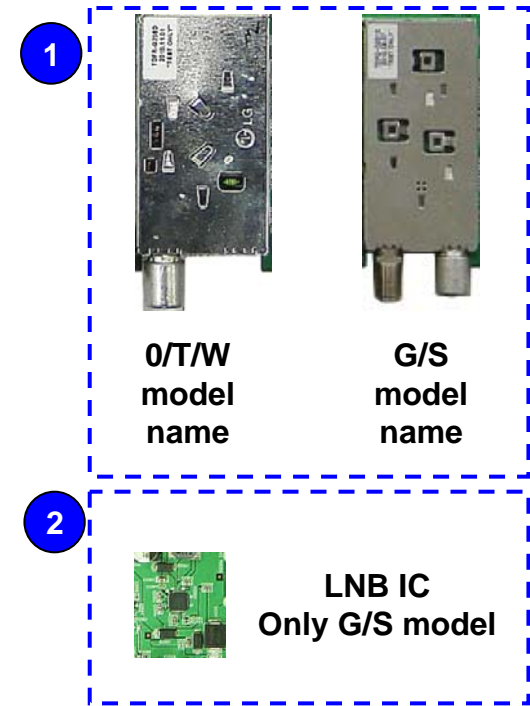
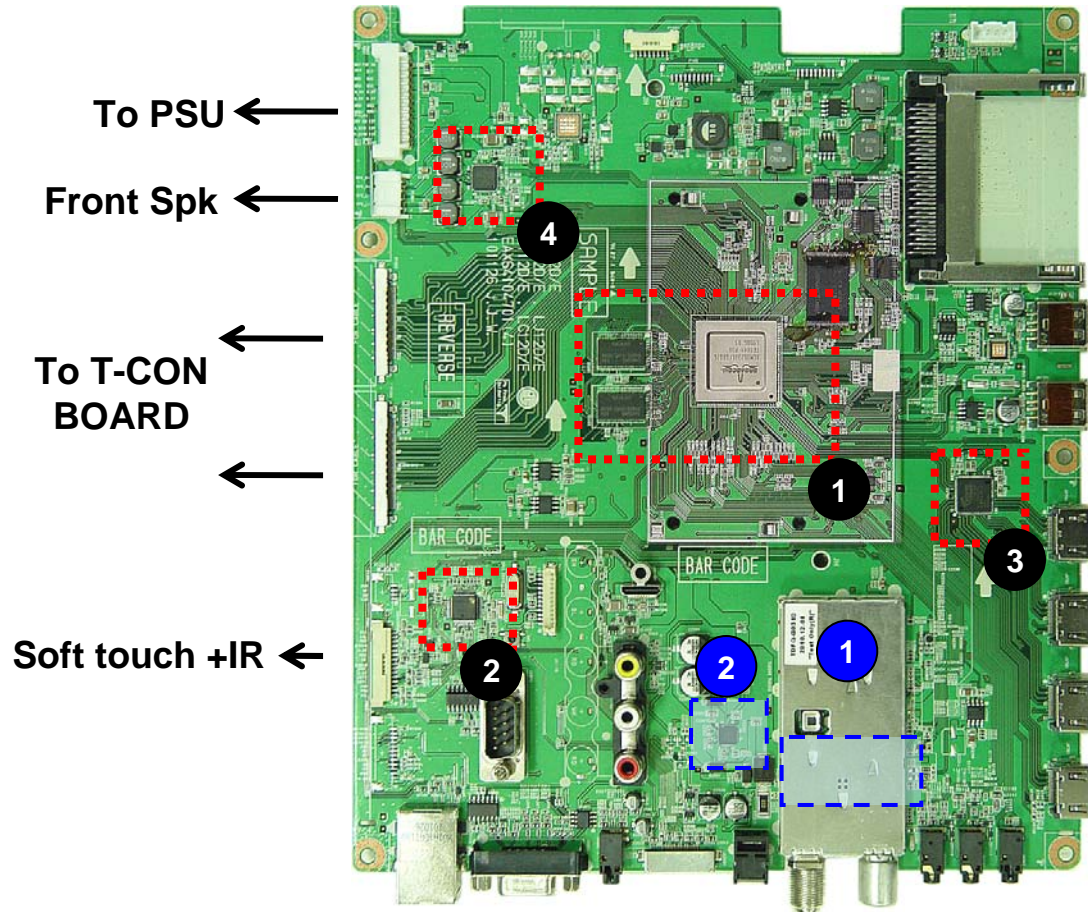

- 1** Main processor, DDR Memory
Flash Memory
- 2** Micom for Key/IR sensing
- 3** HDMI switch (4:1)
- 4** Audio AMP (10W+10W)

Interconnection - 1

XXLW550T/W/S-ZA
XXLW650W/G/S-ZA
XXLW570G/S-ZA

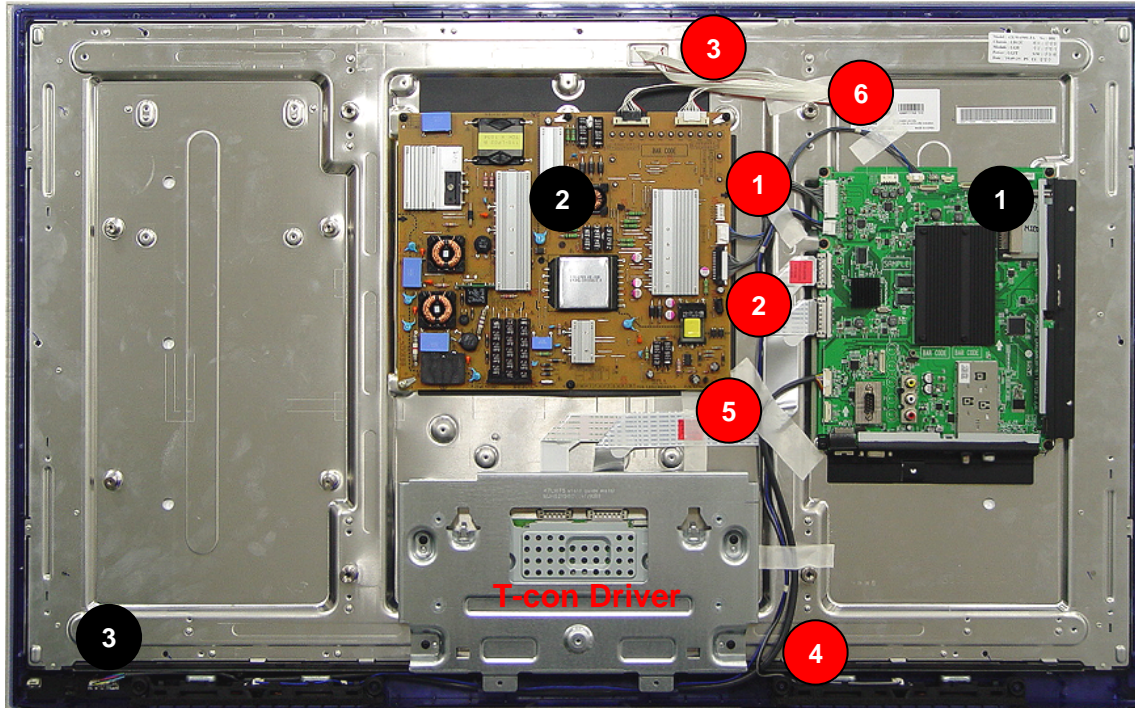

[PCBs]

- 1 Main PCB
- 2 Power Board
- 3 Soft touch + IR Key PCB

[Cables]

- 1 Main / PSU cable
- 2 Main / Module LVDS cable
41&51PIN
- 3 LED driver / PSU
- 4 15Pin (IR+Touch) Cable
- 5 SPK Cable
- 6 Local Dimming Cable

Interconnection - 3

42/47LV5500/T/W/G-ZA
42/47LV570G/S-ZA

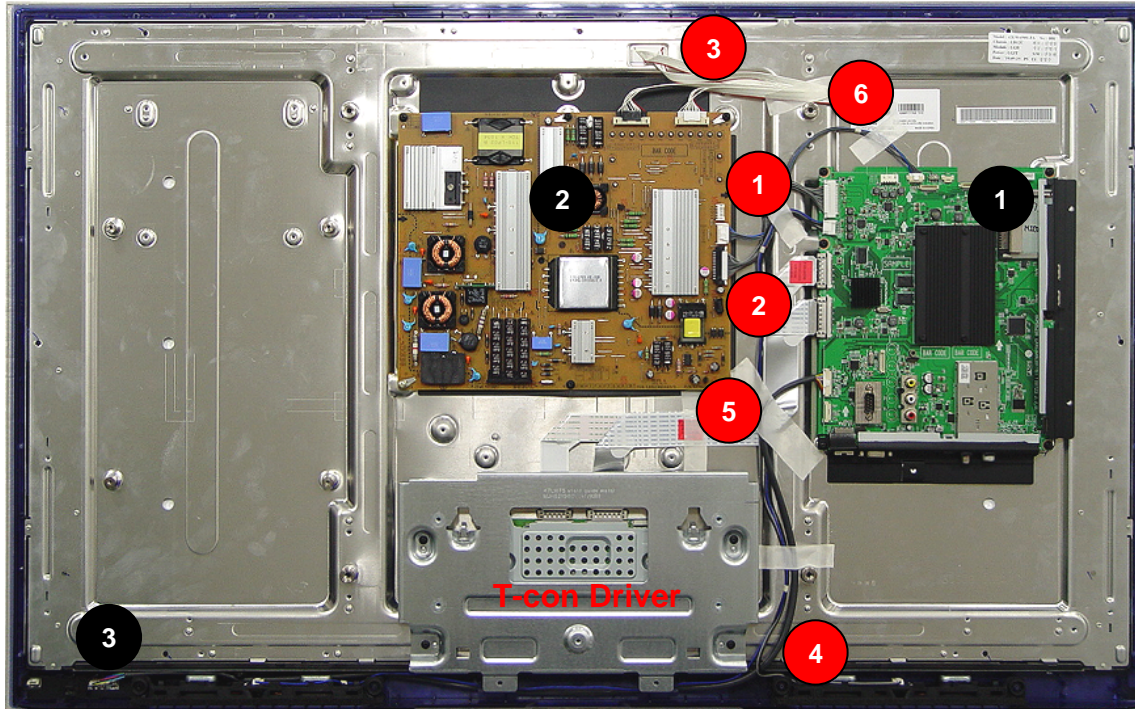

[PCBs]

- 1** Main PCB
- 2** Power Board
- 3** Soft touch + IR Key PCB (LV570 only IR Assy)

[Cables]

- 1** Main / PSU cable
- 2** Main / Module LVDS cable 41&51PIN
- 3** LED driver / PSU
- 4** 15Pin (IR+Touch) Cable
- 5** SPK Cable
- 6** Local Dimming Cable

**Same interconnection LW or LV serie
in the 42"/47"**

Interconnection - 2

32/37LV5500/T/W/G-ZA
32/37LV570G/S-ZA

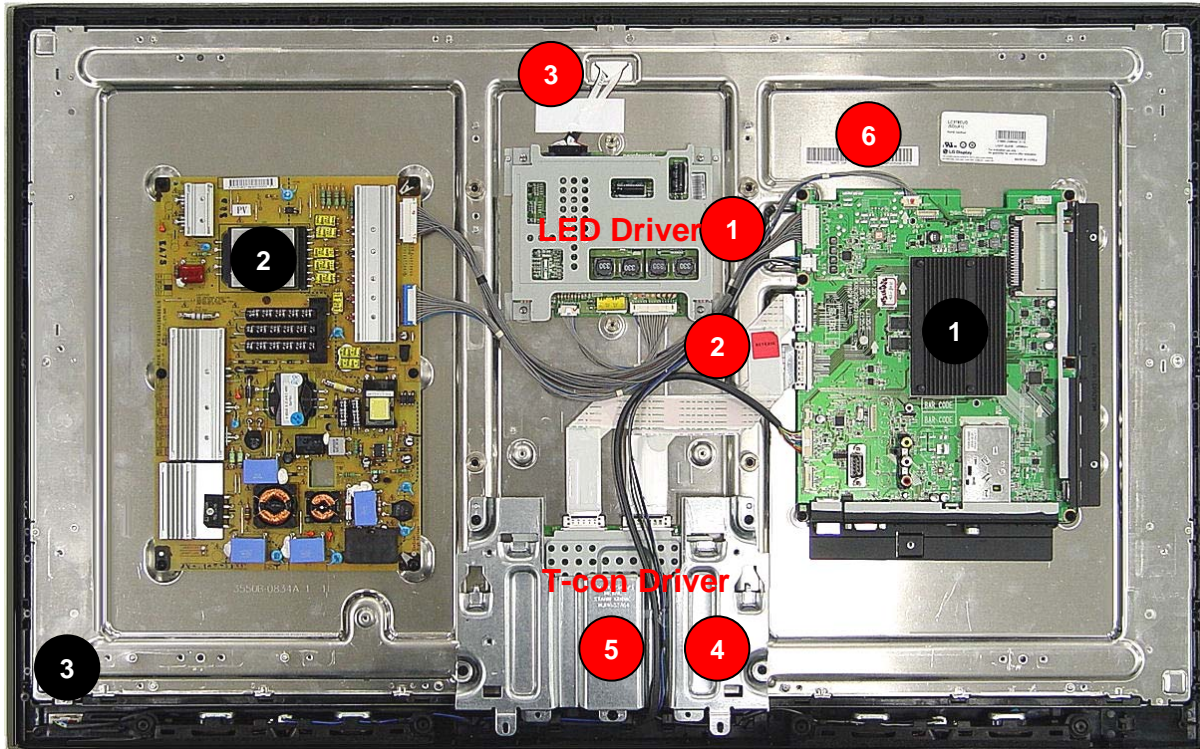

[PCBs]

- 1 Main PCB
- 2 Power Board
- 3 Soft touch + IR Key PCB (LW570 only IR Assy)

[Cables]

- 1 Main / PSU cable
- 2 Main / Module LVDS cable 41&51PIN
- 3 LED driver / PSU
- 4 15Pin (IR+Touch) Cable
- 5 SPK Cable
- 6 Local Dimming Cable

Contents of LCD TV Standard Repair Process

No.	Error symptom (High category)	Error symptom (Mid category)	Page	Remarks
1	A. Video error	No video/Normal audio	1	
2		No video/No audio	2	
3		Video error, video lag/stop, fail tuning	3, 4	
4		Color error	5	
5		Vertical/Horizontal bar, residual image, light spot, external device color error	6	
6	B. Power error	No power	7	
7		Off when on, off while viewing, power auto on/off	8	
8	C. Audio error	No audio/Normal video	9	
9		Wrecked audio/discontinuation/noise	10	
10	D. Function error	No response in remote controller, key error, recording error, memory error	11	
11		External device recognition error	12	
12	E. Noise	Circuit noise, mechanical noise	13	
13	F. Exterior error	Exterior defect	14	

First of all, Check whether there is SVC Bulletin in GCSC System for these model.

LCD TV	Error symptom	A. Video error	Established date	2010. 12 .14	
		No video/ Normal audio	Revised date		1/14

**First of all, Check whether all of cables between board is inserted properly or not.
(Main B/D↔ Power B/D, LVDS Cable,Speaker Cable,IR B/D Cable,,)**

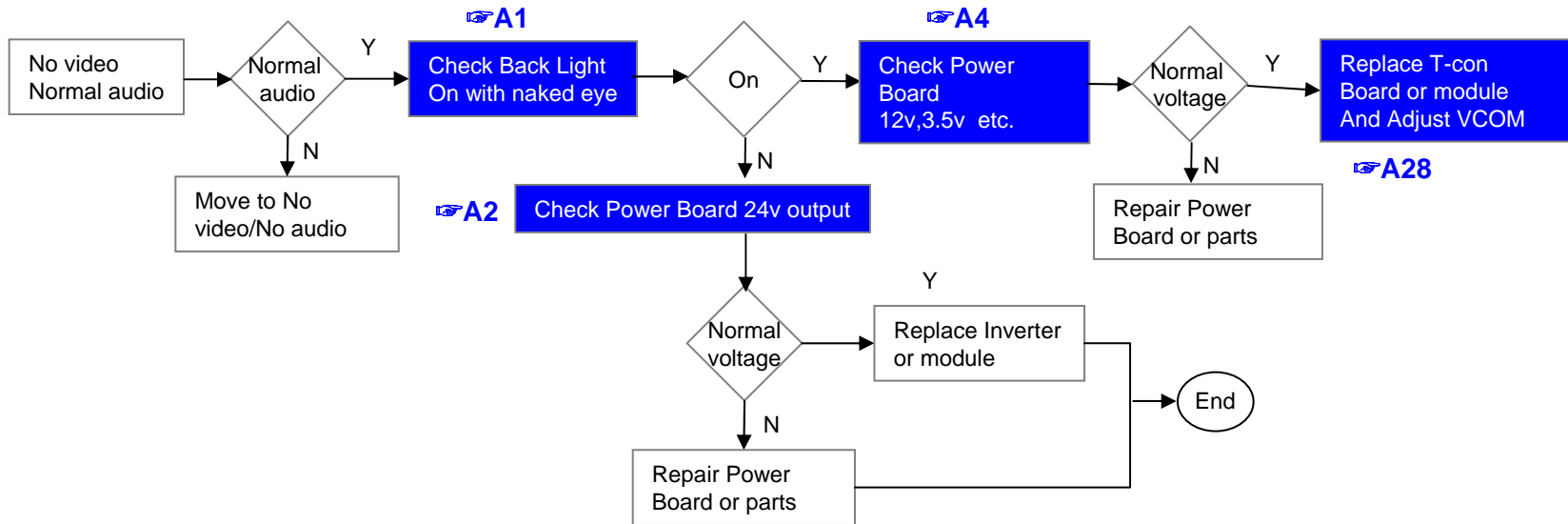

※Precaution A7 & A3



LCD TV	Error symptom	A. Video error	Established date	2010. 12 .14	
		No video/ No audio	Revised date		2/14

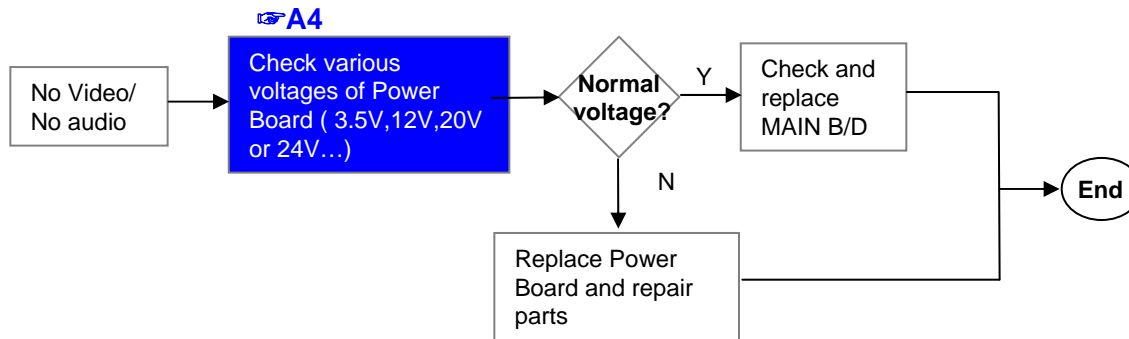

LCD TV	Error symptom	A. Picture Problem	Established date	2010. 12 .14	
		Picture broken/ Freezing	Revised date		3/14

A6

Check RF Signal level

- . By using Digital signal level meter
- . By using Diagnostics menu on OSD
(Menu → Set up → Support → Signal Test)
- Signal strength (Normal : over 50%)
- Signal Quality (Normal: over 50%)

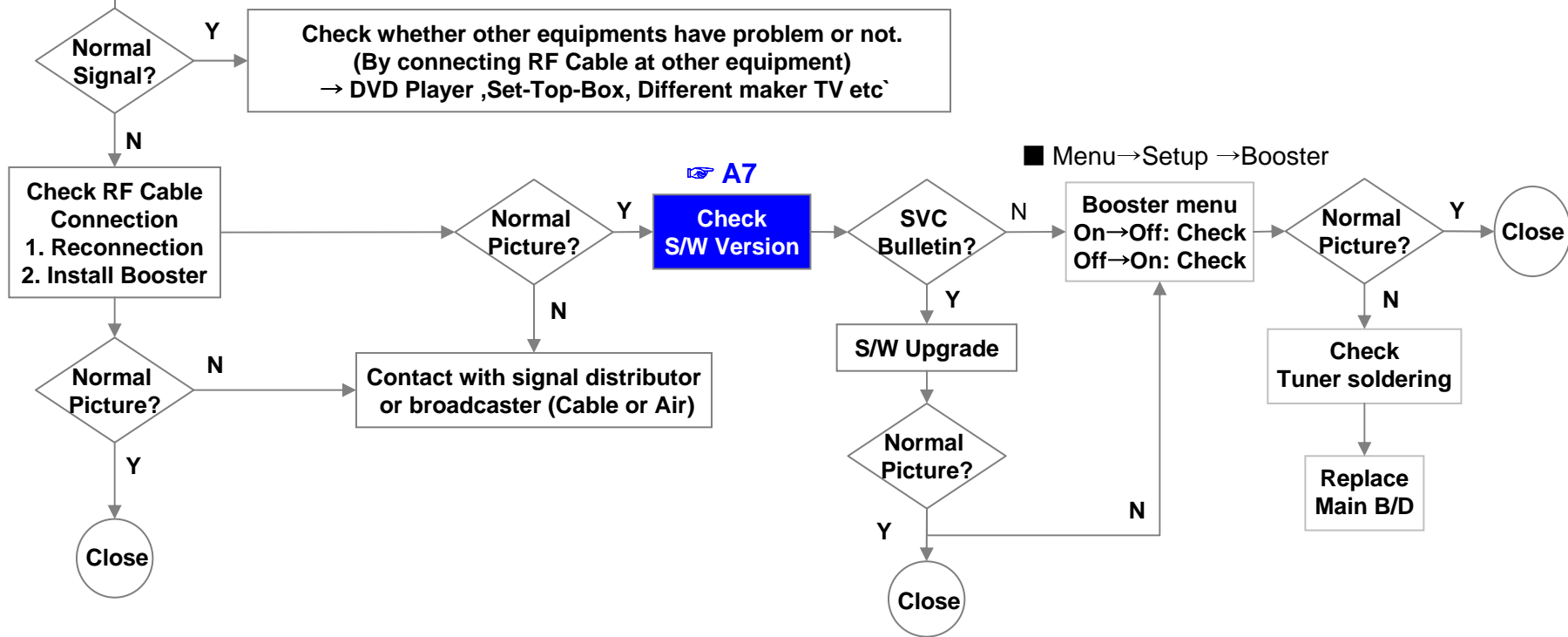

LCD TV	Error symptom	A. Picture Problem (DVB-S/S2)	Established date	2011. 01 .24	
		Tuning fail, Picture broken/ Freezing	Revised date		4/14

A6

Check RF Signal level

Check RF signal cable (DVB satellite signal or not)
 Check whether other equipments have problem or not.
 (By connecting RF Cable at other equipment)
 → Set-Top-Box, Different maker TV etc

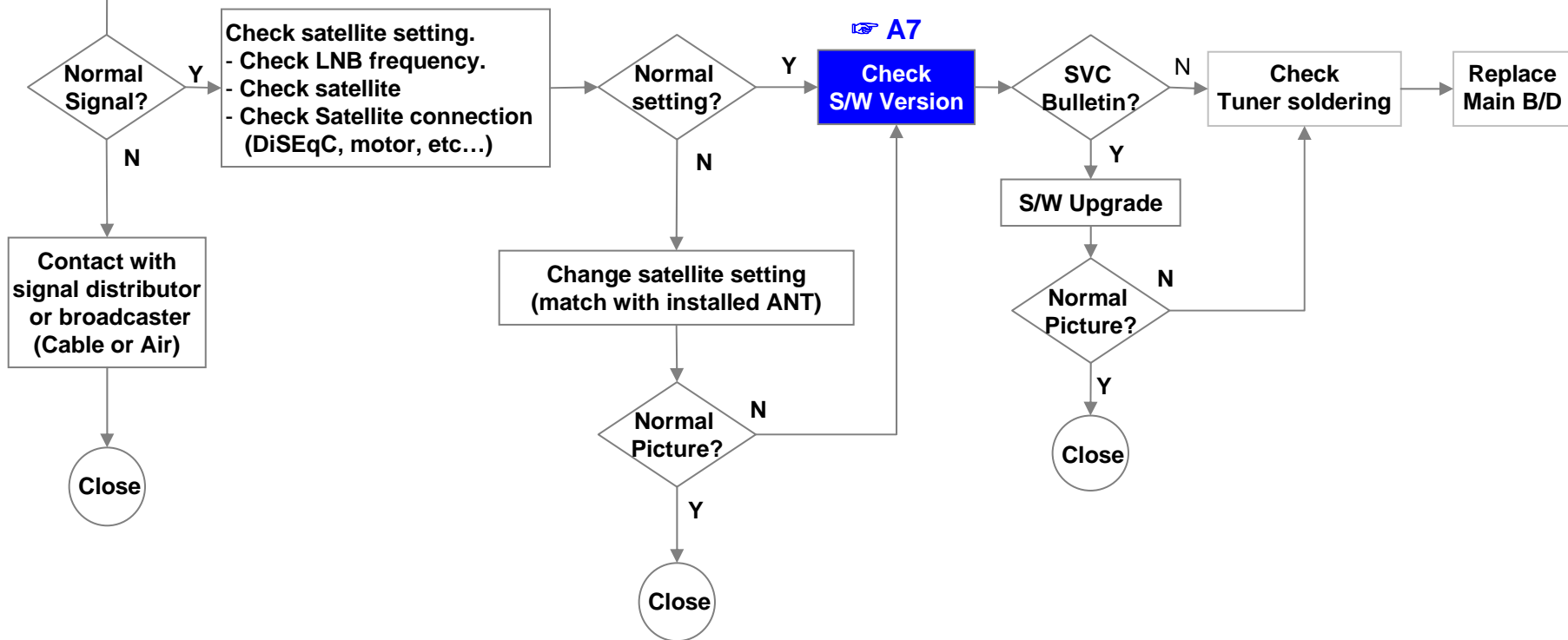

LCD TV	Error symptom	A. Video error	Established date	2010. 12 .14	
		Color error	Revised date		5/14

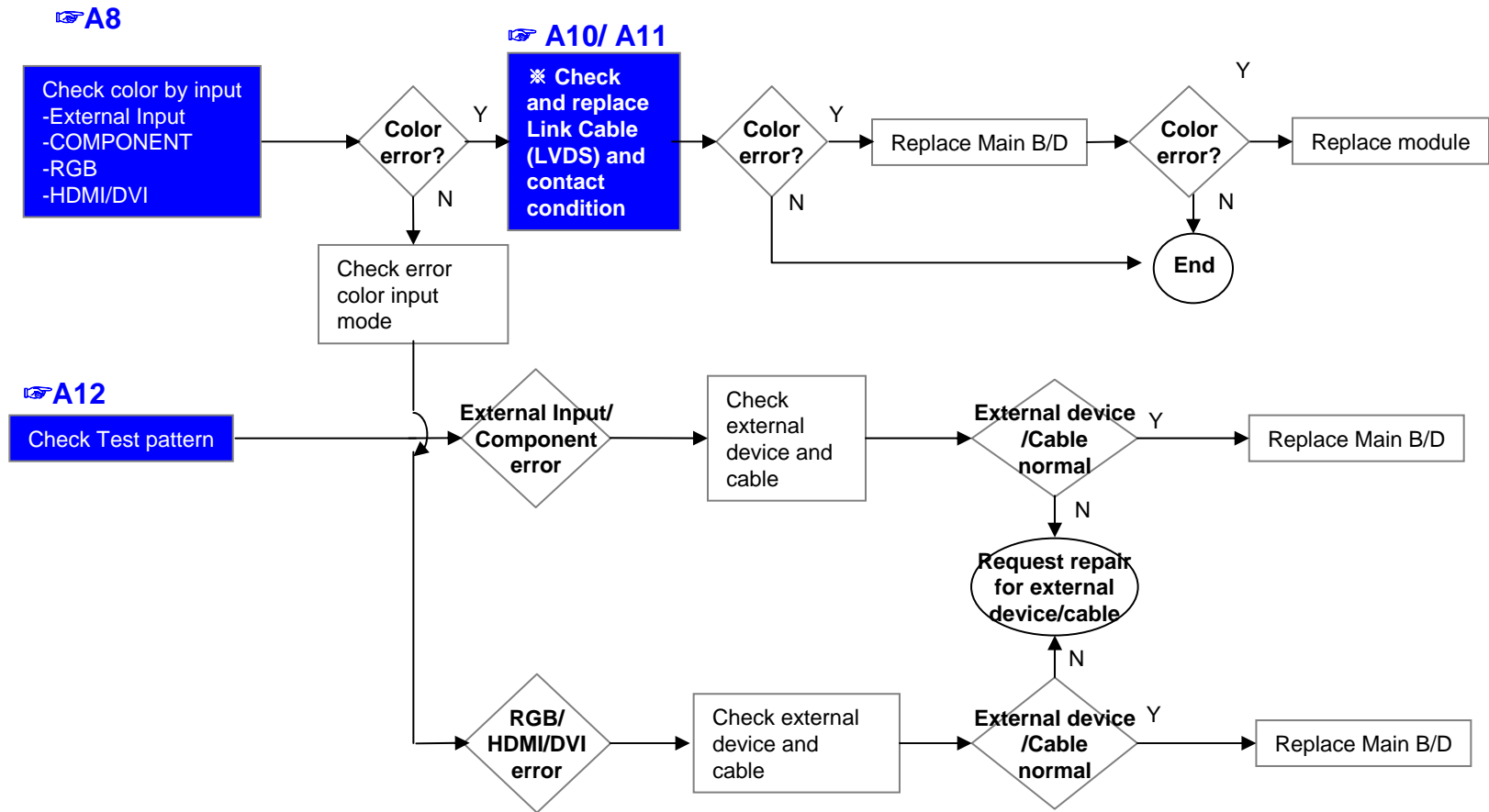

LCD TV	Error symptom	A. Video error	Established date	2010. 12 .14	
		Vertical / Horizontal bar, residual image, light spot, external device color error	Revised date		6/14

Vertical/Horizontal bar, residual image, light spot

A8

Check color condition by input
 -External Input
 -Component
 -RGB
 -HDMI/DVI

A12

Check Test pattern

A10/ A11

Check and replace Link Cable

A28

Replace Main B/D (adjust VCOM)

For LGD panel

For other panel

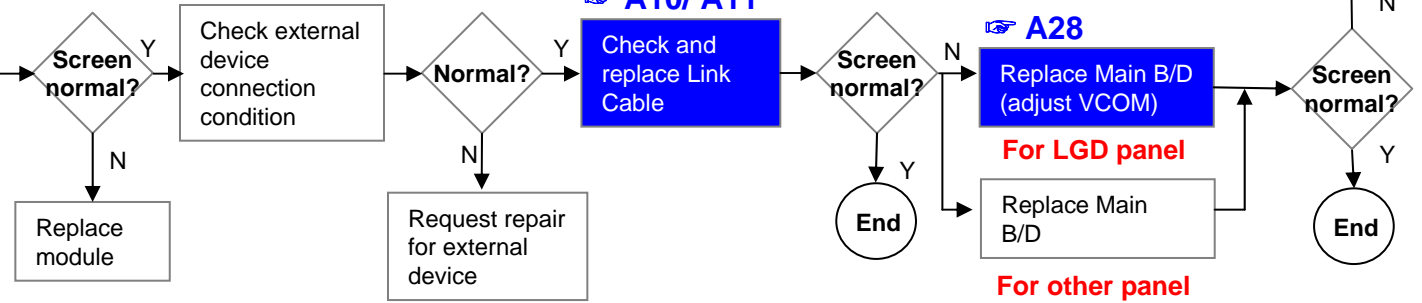

External device screen error-Color error

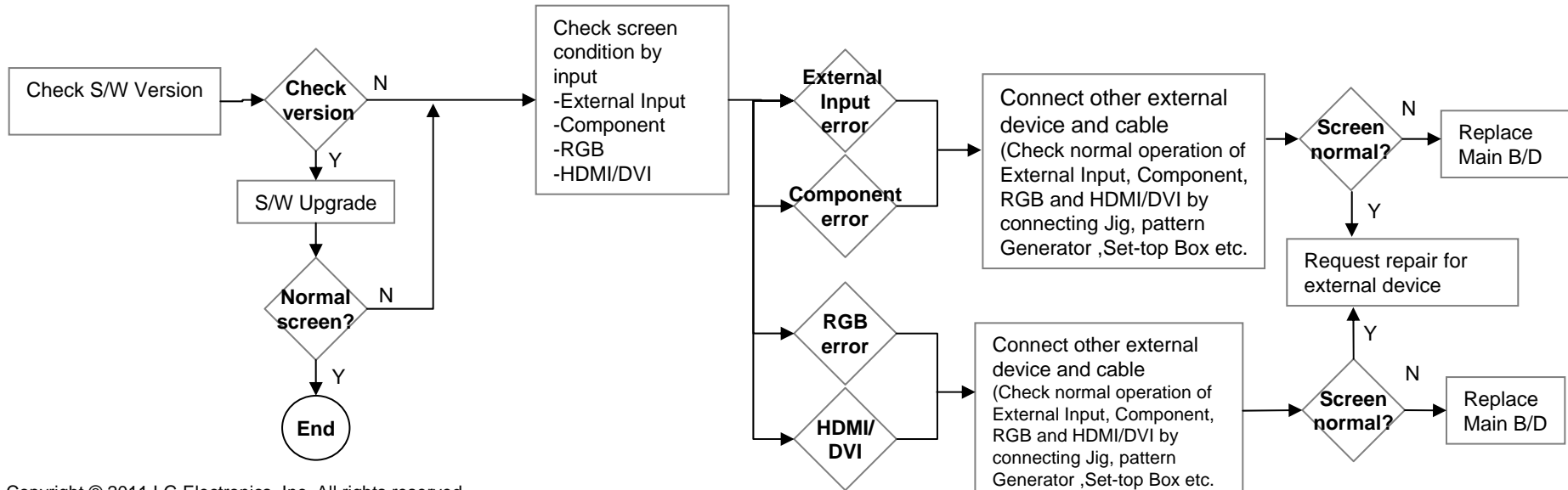

LCD TV	Error symptom	B. Power error	Established date	2010. 12 .14	
		No power	Revised date		7/14

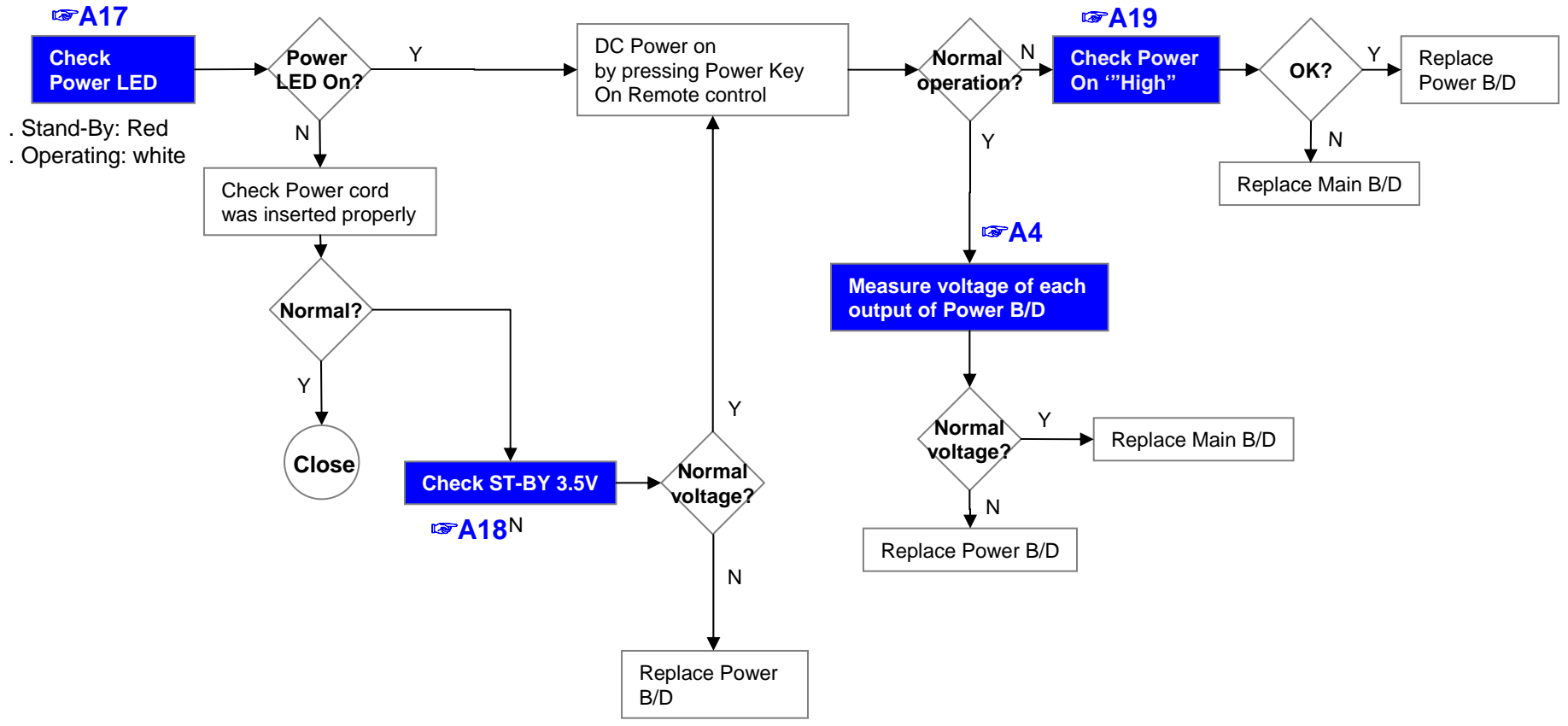

LCD TV	Error symptom	B. Power error	Established date	2010. 12 .14	
		Off when on, off while viewing, power auto on/off	Revised date		8/14

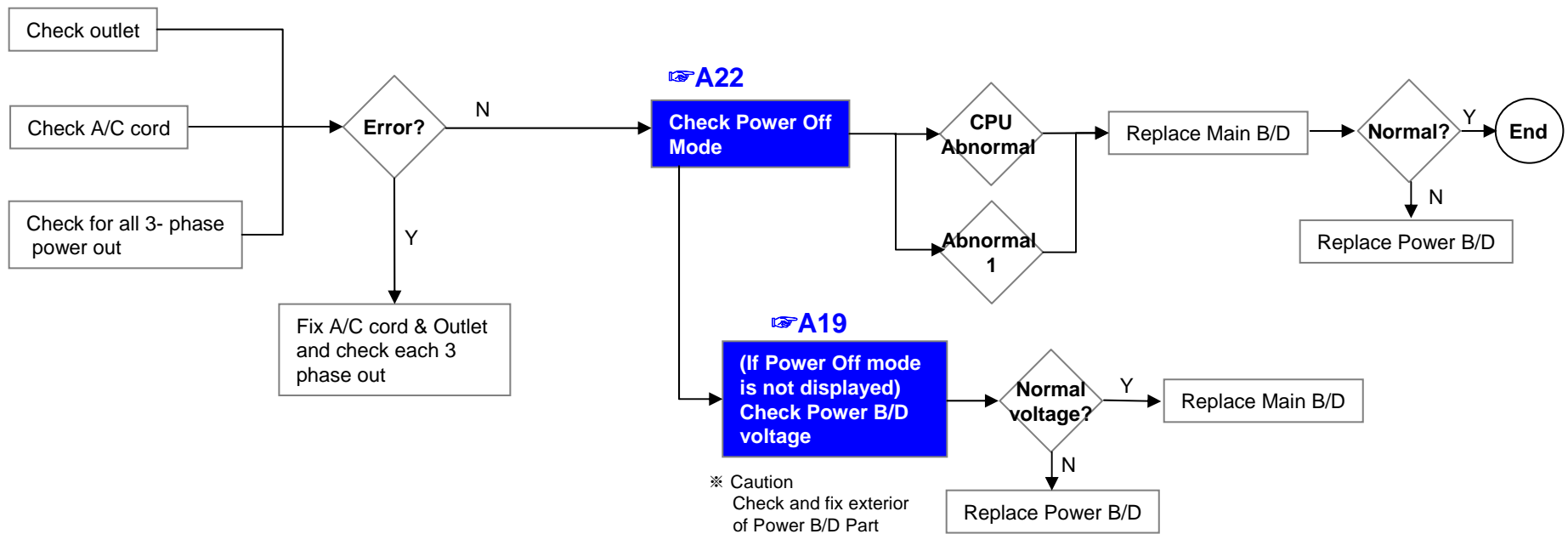

* Please refer to the all cases which can be displayed on power off mode.

Status	Power off List	Explanation
Normal	"POWEROFF_REMOTEKEY"	Power off by REMOTE CONTROL
	"POWEROFF_OFFTIMER"	Power off by OFF TIMER
	"POWEROFF_SLEEPTIMER"	Power off by SLEEP TIMER
	"POWEROFF_INSTOP"	Power off by INSTOP KEY
	"POWEROFF_AUTOOFF"	Power off by AUTO OFF
	"POWEROFF_ONTIMER"	Power off by ON TIMER
	"POWEROFF_RS232C"	Power off by RS232C
	"POWEROFF_RESREC"	Power off by Reserved Record
	"POWEROFF_RECEND"	Power off by End of Recording
	"POWEROFF_SWDOWN"	Power off by S/W Download
	"POWEROFF_UNKNOWN"	Power off by unknown status except listed case
Abnormal	"POWEROFF_ABNORMAL1"	Power off by abnormal status except CPU trouble
	"POWEROFF_CPUABNORMAL"	Power off by CPU Abnormal

LCD TV	Error symptom	C. Audio error	Established date	2010. 12 .14	
		No audio/ Normal video	Revised date		9/14

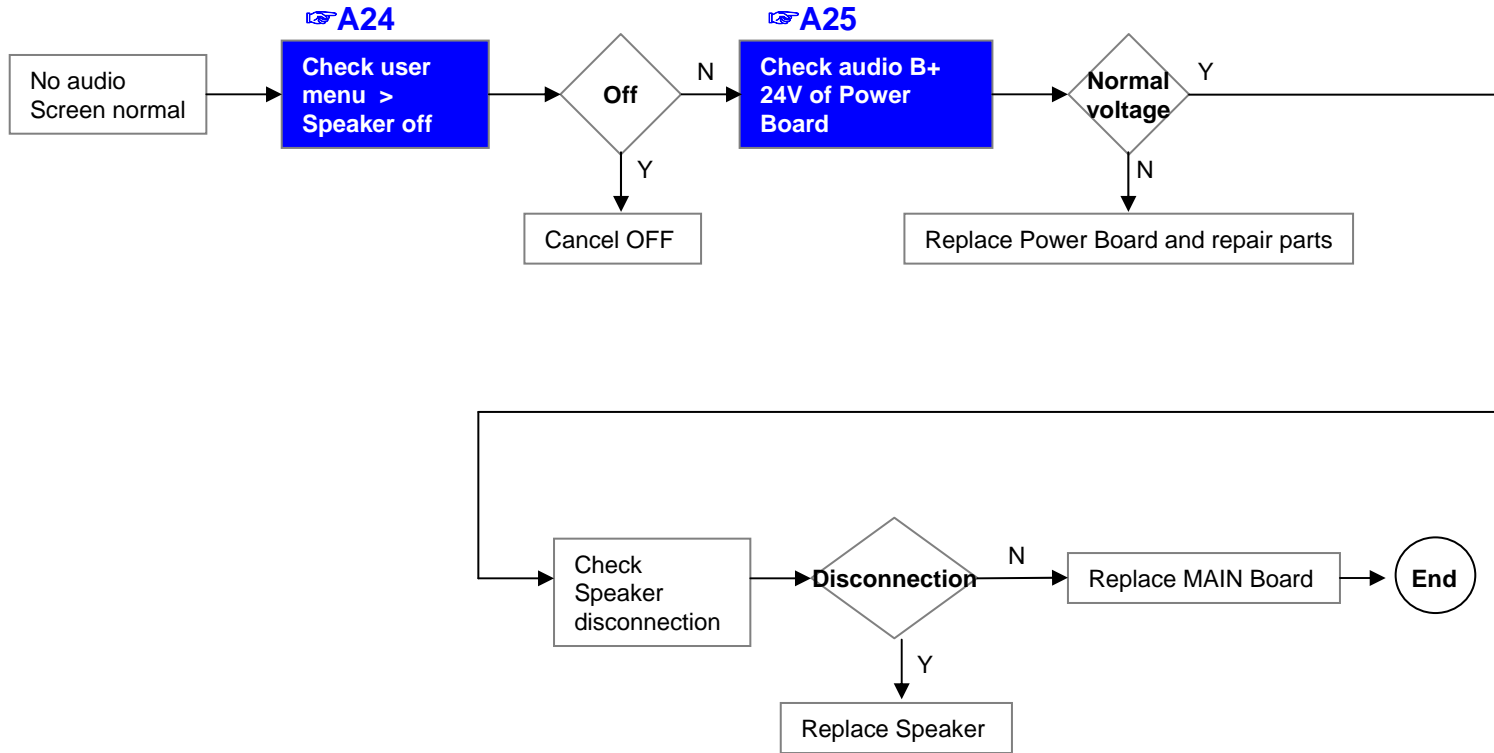

LCD TV	Error symptom	C. Audio error	Established date	2010. 12 .14	
		Wrecked audio/ discontinuation/noise	Revised date		10/14

→ abnormal audio/discontinuation/noise is same after “Check input signal” compared to No audio

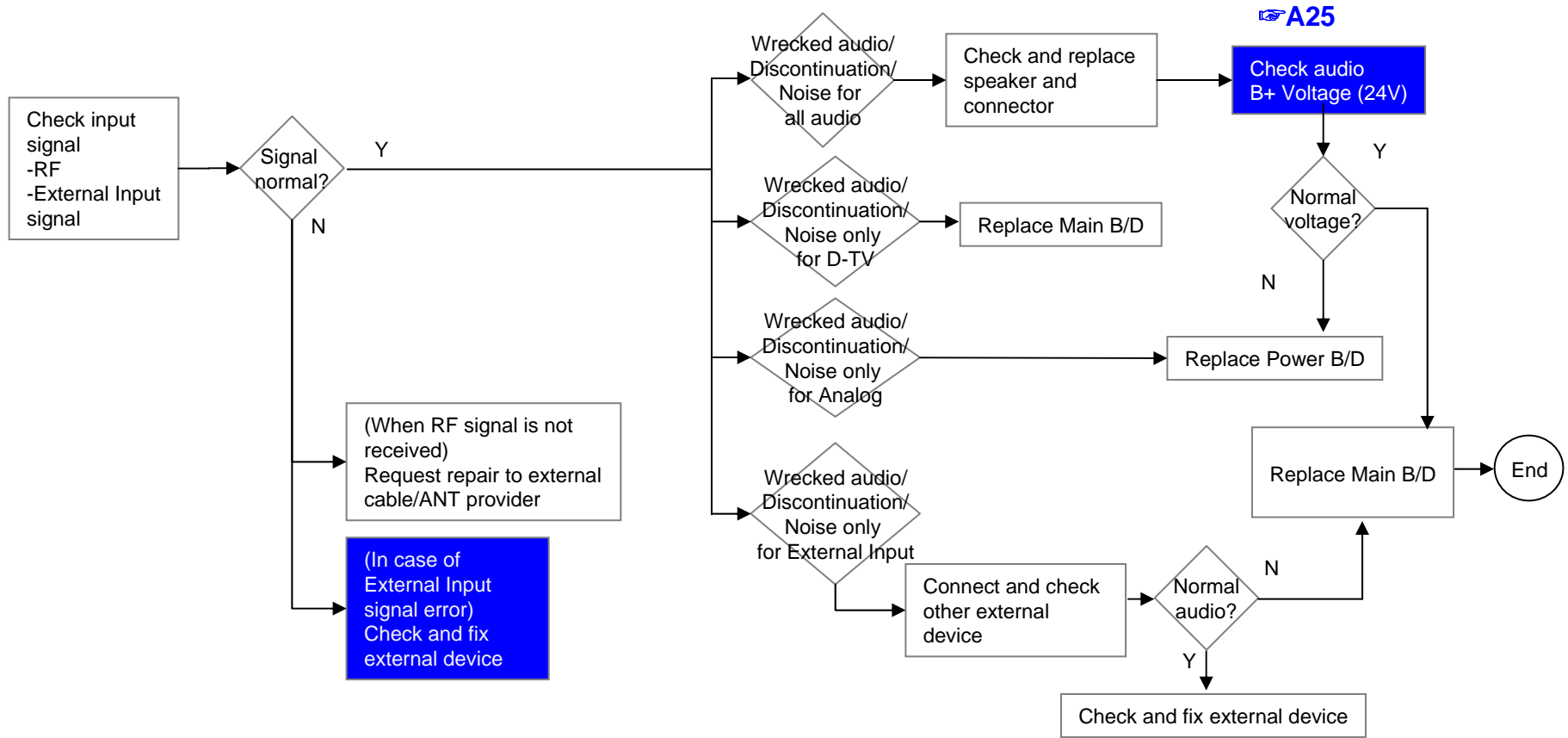

LCD TV	Error symptom	D. General Function Problem	Established date	2010. 12 .14	
		Remote control & Local switch checking	Revised date		11/14

1. Remote control(R/C) operating error

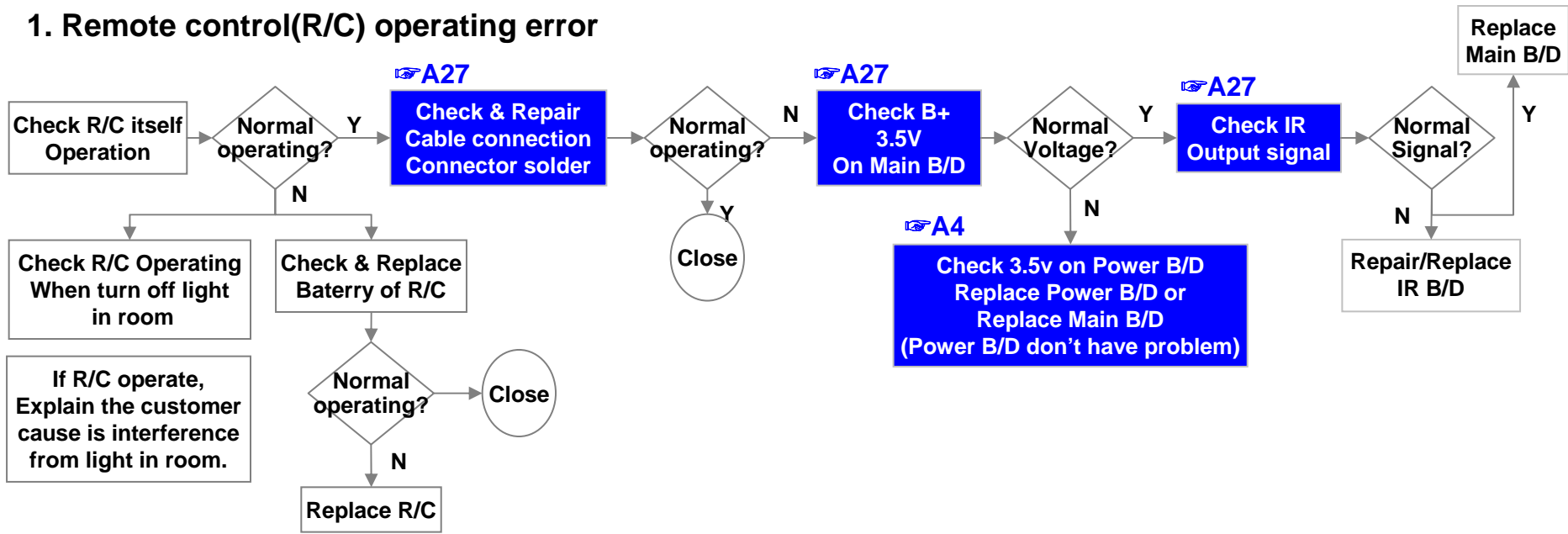

LCD TV	Error symptom	D. Function error	Established date	2010. 12 .14	
		External device recognition error	Revised date		12/14

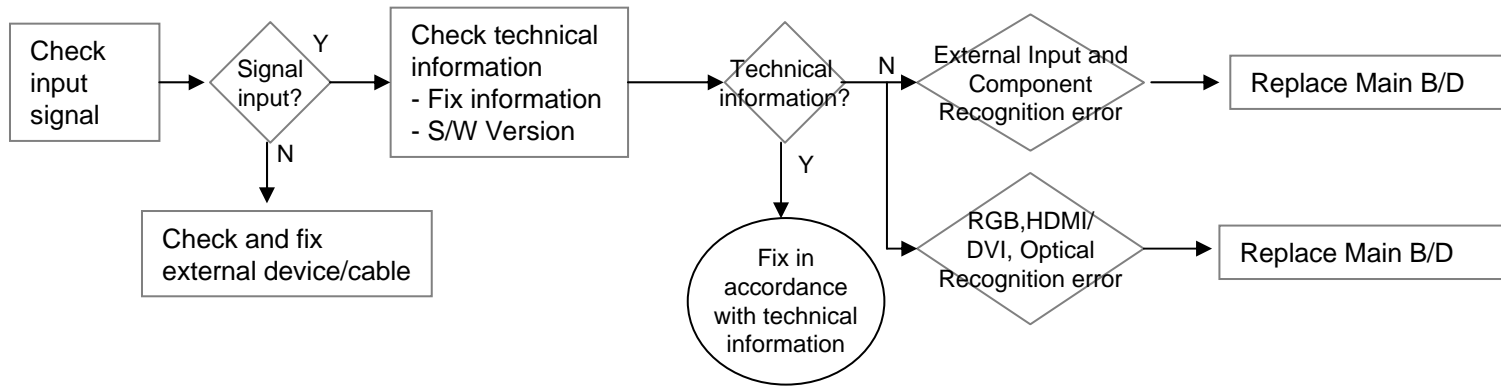

LCD TV	Error symptom	E. Noise	Established date	2010. 12 .14	
		Circuit noise, mechanical noise	Revised date		13/14

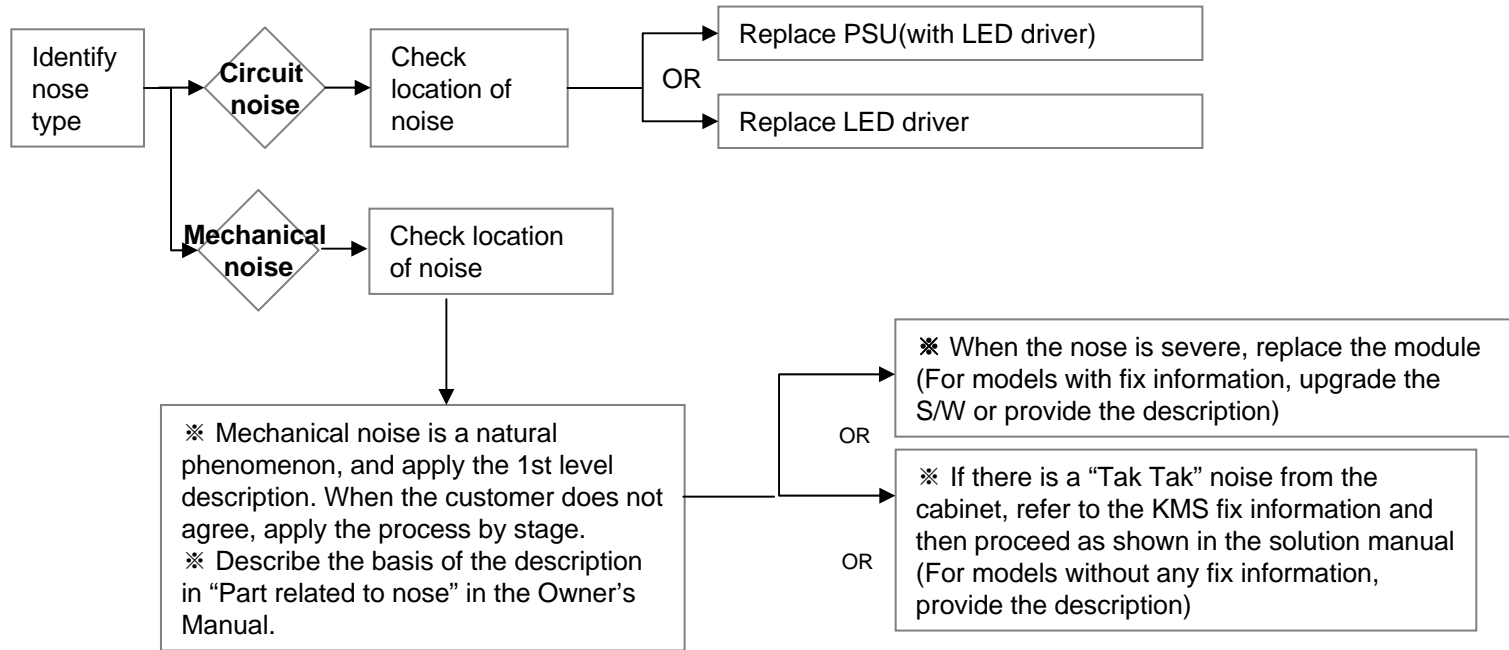

LCD TV	Error symptom	F. Exterior defect	Established date	2010. 12 .14	
		Exterior defect	Revised date		14/14

