

Service  
Service  
**Service**



19120\_000\_110511.eps  
110919

# Service Manual

Contents	Page
<a href="#">1. Revision List</a>	<a href="#">2</a>
<a href="#">2. Technical Specs, Diversity, and Connections</a>	<a href="#">2</a>
<a href="#">3. Precautions, Notes, and Abbreviation List</a>	<a href="#">5</a>
<a href="#">4. Mechanical Instructions</a>	<a href="#">9</a>
<a href="#">5. Service Modes, Error Codes, and Fault Finding</a>	<a href="#">16</a>
<a href="#">6. Alignments</a>	<a href="#">24</a>
<a href="#">7. Circuit Descriptions</a>	<a href="#">26</a>
<a href="#">8. IC Data Sheets</a>	<a href="#">33</a>
<a href="#">9. Block Diagrams</a>	
<a href="#">Wiring diagram 19" Golden horse</a>	<a href="#">39</a>
<a href="#">Wiring diagram 22" Golden horse</a>	<a href="#">40</a>
<a href="#">Wiring diagram 22" Spot Deal</a>	<a href="#">41</a>
<a href="#">Wiring diagram 26" Golden horse</a>	<a href="#">42</a>
<a href="#">Wiring diagram 32" Spot Deal</a>	<a href="#">43</a>
<a href="#">Block Diagram</a>	<a href="#">44</a>
<a href="#">10. Circuit Diagrams and PWB Layouts</a>	<i>Drawing PWB</i>
<a href="#">A01 715G4899 PSU 19" and 22"</a>	<a href="#">45</a>
<a href="#">Adapter</a>	(A01) <a href="#">45</a> <a href="#">47-48</a>
<a href="#">Inverter</a>	(A02) <a href="#">46</a> <a href="#">47-48</a>
<a href="#">A01 715G5043 PSU 26"</a>	<a href="#">49</a>
<a href="#">Inverter</a>	(A01) <a href="#">49</a> <a href="#">51-52</a>
<a href="#">Power</a>	(A02) <a href="#">50</a> <a href="#">51-52</a>
<a href="#">A01 715G5147 PSU Spot Deal 22"</a>	<a href="#">53</a>
<a href="#">Power</a>	(A01) <a href="#">53</a> <a href="#">55-56</a>
<a href="#">LED driver</a>	(A02) <a href="#">54</a> <a href="#">55-56</a>
<a href="#">A01 715G4697 PSU Spot Deal 32"</a>	<a href="#">57</a>
<a href="#">AC side</a>	(A01) <a href="#">57</a> <a href="#">62-63</a>
<a href="#">Standby</a>	(A02) <a href="#">58</a> <a href="#">62-63</a>
<a href="#">Secondary power</a>	(A03) <a href="#">59</a> <a href="#">62-63</a>
<a href="#">Main power</a>	(A04) <a href="#">60</a> <a href="#">62-63</a>
<a href="#">LED driver</a>	(A05) <a href="#">61</a> <a href="#">62-63</a>
<a href="#">B 715G4796 SSB</a>	<a href="#">64</a>
<a href="#">Power-1</a>	(B01) <a href="#">64</a> <a href="#">75-76</a>
<a href="#">Power-2</a>	(B02) <a href="#">65</a> <a href="#">75-76</a>

Contents	Page
<a href="#">MT5366 cvou</a>	(B03) <a href="#">66</a> <a href="#">75-76</a>
<a href="#">FLASH/UART/IR/JTAG</a>	(B04) <a href="#">67</a> <a href="#">75-76</a>
<a href="#">SPK AMP / HP AMP / AUD MUX</a>	(B05) <a href="#">68</a> <a href="#">75-76</a>
<a href="#">SCART I/O / HDMI1 INPUT</a>	(B06) <a href="#">69</a> <a href="#">75-76</a>
<a href="#">YPBPR/ VGA INPUT</a>	(B07) <a href="#">70</a> <a href="#">75-76</a>
<a href="#">DDR3 DRAM</a>	(B08) <a href="#">71</a> <a href="#">75-76</a>
<a href="#">LVDS OUTPUT/USB</a>	(B09) <a href="#">72</a> <a href="#">75-76</a>
<a href="#">DVB-T+C DEMOD MT5135 / CI</a>	(B10) <a href="#">73</a> <a href="#">75-76</a>
<a href="#">DVB-T+C TUNER</a>	(B11) <a href="#">74</a> <a href="#">75-76</a>
<a href="#">J 715G4939 IR Golden horse</a>	<a href="#">77</a>
<a href="#">IR/LED board</a>	(J) <a href="#">77</a> <a href="#">78</a>
<a href="#">J 715G5219 IR Spot Deal 22"</a>	<a href="#">79</a>
<a href="#">IR/LED board</a>	(J) <a href="#">79</a> <a href="#">80</a>
<a href="#">J 715G5217 IR Spot Deal 32"</a>	<a href="#">81</a>
<a href="#">IR/LED board</a>	(J) <a href="#">81</a> <a href="#">82</a>
<a href="#">E 715G5218 Keyboard Spot Deal</a>	<a href="#">83</a>
<a href="#">Keyboard</a>	(E) <a href="#">83</a> <a href="#">84</a>
<a href="#">11. Styling Sheets</a>	
<a href="#">Golden horse 19"</a>	<a href="#">85</a>
<a href="#">Golden horse 22"</a>	<a href="#">86</a>
<a href="#">Spot Deal 22"</a>	<a href="#">87</a>
<a href="#">Golden horse 26"</a>	<a href="#">88</a>
<a href="#">Spot Deal 32"</a>	<a href="#">89</a>

©Copyright 2011 Koninklijke Philips N.V.  
All rights reserved. No part of this publication may be reproduced, stored in a retrieval system or transmitted, in any form or by any means, electronic, mechanical, photocopying, or otherwise without the prior permission of Philips.

# 1. Revision List

## Manual xxxx xxx xxxx.0

- First release.

## Manual xxxx xxx xxxx.1

- **Chapter 2:** Added new models to [Table 2-1](#), added Spot Deal styling.
- **Chapter 2:** Corrected the output signal specification of the SCART connector.

- **Chapter 4:** added cable dressing and mechanical information for the news sets.
- **Chapter 6:** updated table 6-1 White tone default settings and updated table 6-2 Display code overview.
- **Chapter 9:** Added wiring diagram, block diagrams and power diagrams.
- **Chapter 11:** Added Styling Sheets for the new stylings.

# 2. Technical Specs, Diversity, and Connections

## Index of this chapter:

[2.1 Technical Specifications](#)

[2.2 Directions for Use](#)

[2.3 Connections](#)

[2.4 Chassis Overview](#)

## Notes:

- Figures can deviate due to the different set executions.
- Specifications are indicative (subject to change).

## 2.2 Directions for Use

Directions for use can be downloaded from the following websites:

<http://www.philips.com/support>

<http://www.p4c.philips.com>

## 2.1 Technical Specifications

For on-line product support please use the links in. Here is product information available, as well as getting started, user manuals, frequently asked questions and software & drivers.

**Table 2-1 Described Model Numbers:**

Model Number	Styling	Published in
<a href="#">19HFL3233D/10</a>	Golden horse	3122 785 19120
<a href="#">19PFL3606H/12</a>	Golden horse	3122 785 19120
<a href="#">19PFL3606H/58</a>	Golden horse	3122 785 19120
<a href="#">19PFL3606H/60</a>	Golden horse	3122 785 19120
<a href="#">22PFL3206H/12</a>	Spot Deal	3122 785 19121
<a href="#">22PFL3206H/58</a>	Spot Deal	3122 785 19121
<a href="#">22PFL3606H/12</a>	Golden horse	3122 785 19120
<a href="#">22PFL3606H/58</a>	Golden horse	3122 785 19120
<a href="#">22PFL3606H/60</a>	Golden horse	3122 785 19120
<a href="#">26PFL3606H/12</a>	Golden horse	3122 785 19120
<a href="#">26PFL3606H/58</a>	Golden horse	3122 785 19120
<a href="#">26PFL3606H/60</a>	Golden horse	3122 785 19120
<a href="#">32PFL5206H/12</a>	Spot Deal	3122 785 19121
<a href="#">32PFL5206H/58</a>	Spot Deal	3122 785 19121
<a href="#">32PFL5206H/60</a>	Spot Deal	3122 785 19121

**Note:** The given Model Numbers are subject to change.

2.3 Connections

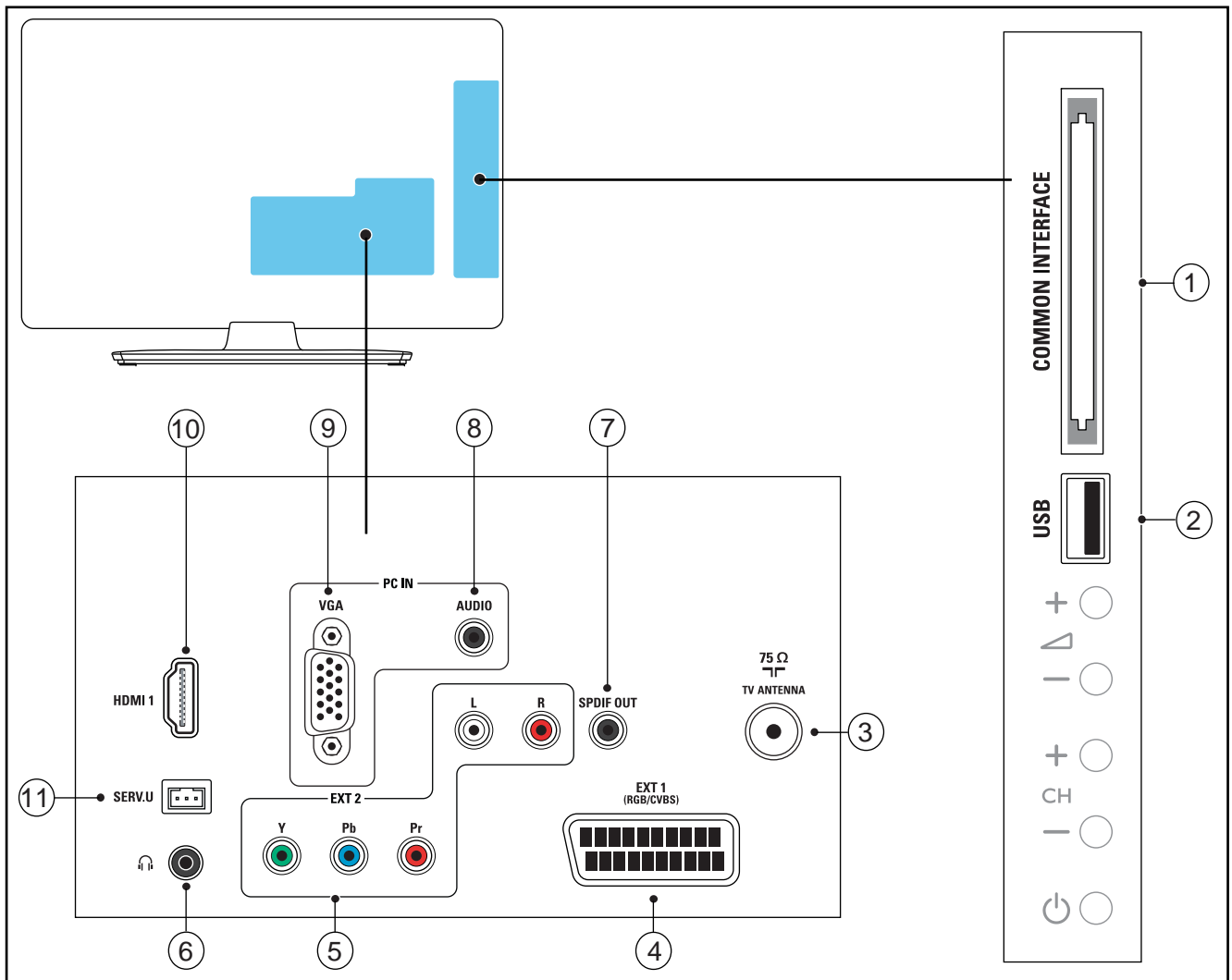

19120\_001\_110511.eps  
110524

Figure 2-1 Connection overview

**Note:** The following connector colour abbreviations are used (acc. to DIN/IEC 757): Bk= Black, Bu= Blue, Gn= Green, Gy= Grey, Rd= Red, Wh= White, Ye= Yellow.

2.3.2 Rear Connections

3 - TV ANTENNA - In

Signal input from an antenna, cable or satellite.

2.3.1 Side Connections

1 - Common Interface

68p - See diagram

[DVB-T+C\\_DEMOD\\_MT5135 / CI.](#)



2 - USB2.0



10000\_022\_090121.eps  
090121

Figure 2-2 USB (type A)

- 1 - +5V
- 2 - Data (-)
- 3 - Data (+)
- 4 - Ground

Gnd

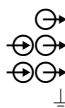

**4 - EXT1: Video RGB/YC - In, CVBS - In/Out, Audio - In/Out**

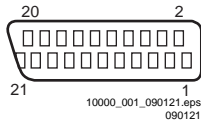

Figure 2-3 SCART connector

1	- n.c.		
2	- Audio R	0.5 V <sub>RMS</sub> / 10 kΩ	⊕
3	- n.c.		
4	- Ground Audio	Gnd	⊖
5	- Ground Blue	Gnd	⊖
6	- Audio L	0.5 V <sub>RMS</sub> / 10 kΩ	⊕
7	- Video Blue/C-out	0.7 V <sub>PP</sub> / 75 Ω	⊕ ⊖
8	- Function Select	0 - 2 V: INT 4.5 - 7 V: EXT 16:9 9.5 - 12 V: EXT 4:3	⊕
9	- Ground Green	Gnd	⊖
10	- n.c.		
11	- Video Green	0.7 V <sub>PP</sub> / 75 Ω	⊕
12	- n.c.		
13	- Ground Red	Gnd	⊖
14	- Ground P50	Gnd	⊖
15	- Video Red/C	0.7 V <sub>PP</sub> / 75 Ω	⊕
16	- Status/FBL	0 - 0.4 V: INT 1 - 3 V: EXT / 75 Ω	⊕
17	- Ground Video	Gnd	⊖
18	- Ground FBL	Gnd	⊖
19	- n.c.		
20	- Video CVBS/Y	1 V <sub>PP</sub> / 75 Ω	⊕
21	- Shield	Gnd	⊖

**5 - EXT2: Video YPbPr - In, Audio - In**

Gn	- Video - Y	1 V <sub>PP</sub> / 75 Ω	⊕ ⊖
Bu	- Video - Pb	0.7 V <sub>PP</sub> / 75 Ω	⊕ ⊖
Rd	- Video - Pr	0.7 V <sub>PP</sub> / 75 Ω	⊕ ⊖
Wh	- Audio - L	0.5 V <sub>RMS</sub> / 10 kΩ	⊕ ⊖
Rd	- Audio - R	0.5 V <sub>RMS</sub> / 10 kΩ	⊕ ⊖

**6 - Head phone (Output)**

Bk	- Head phone	80 - 600 Ω / 10 mW	⊕ ⊖
----	--------------	--------------------	-----

**7 - Cinch: S/PDIF - Out**

Bk	- Coaxial	0.4 - 0.6V <sub>PP</sub> / 75 Ω	⊕ ⊖
----	-----------	---------------------------------	-----

**8 - Audio - In: Left / Right, VGA**

Gn	- Audio L/R in	0.5 V <sub>RMS</sub> / 10 kΩ	⊕ ⊖
----	----------------	------------------------------	-----

**9 - PC IN:VGA**

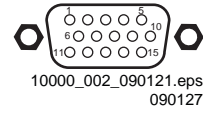

Figure 2-4 VGA connector

1	- Video Red	0.7 V <sub>PP</sub> / 75 Ω	⊕
2	- Video Green	0.7 V <sub>PP</sub> / 75 Ω	⊕
3	- Video Blue	0.7 V <sub>PP</sub> / 75 Ω	⊕
4	- n.c.		
5	- Ground	Gnd	⊖
6	- Ground Red	Gnd	⊖
7	- Ground Green	Gnd	⊖
8	- Ground Blue	Gnd	⊖
9	- +5V <sub>DC</sub>	+5 V	⊕
10	- Ground Sync	Gnd	⊖
11	- Ground Red	Gnd	⊖
12	- DDC_SDA	DDC data	⊕
13	- H-sync	0 - 5 V	⊕
14	- V-sync	0 - 5 V	⊕
15	- DDC_SCL	DDC clock	⊕

**10 - HDMI: Digital Video, Digital Audio - In**

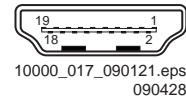

Figure 2-5 HDMI (type A) connector

1	- D2+	Data channel	⊕
2	- Shield	Gnd	⊖
3	- D2-	Data channel	⊕
4	- D1+	Data channel	⊕
5	- Shield	Gnd	⊖
6	- D1-	Data channel	⊕
7	- D0+	Data channel	⊕
8	- Shield	Gnd	⊖
9	- D0-	Data channel	⊕
10	- CLK+	Data channel	⊕
11	- Shield	Gnd	⊖
12	- CLK-	Data channel	⊕
13	- Easylink/CEC	Control channel	⊕ ⊖
14	- n.c.		
15	- DDC_SCL	DDC clock	⊕
16	- DDC_SDA	DDC data	⊕ ⊖
17	- Ground	Gnd	⊖
18	- +5V		⊕
19	- HPD	Hot Plug Detect	⊕
20	- Ground	Gnd	⊖

**11 - Service / UART**

1	- Ground	Gnd	⊖
2	- UART_TX	Transmit	⊕
3	- UART_RX	Receive	⊕

**2.4 Chassis Overview**

Refer to [9. Block Diagrams](#) for PWB/CBA locations.



## 3. Precautions, Notes, and Abbreviation List

### Index of this chapter:

[3.1 Safety Instructions](#)

[3.2 Warnings](#)

[3.3 Notes](#)

[3.4 Abbreviation List](#)

### 3.1 Safety Instructions

Safety regulations require the following **during** a repair:

- Connect the set to the Mains/AC Power via an isolation transformer (> 800 VA).
- Replace safety components, indicated by the symbol ▲, only by components identical to the original ones. Any other component substitution (other than original type) may increase risk of fire or electrical shock hazard.

Safety regulations require that **after** a repair, the set must be returned in its original condition. Pay in particular attention to the following points:

- Route the wire trees correctly and fix them with the mounted cable clamps.
- Check the insulation of the Mains/AC Power lead for external damage.
- Check the strain relief of the Mains/AC Power cord for proper function.
- Check the electrical DC resistance between the Mains/AC Power plug and the secondary side (only for sets that have a Mains/AC Power isolated power supply):
  1. Unplug the Mains/AC Power cord and connect a wire between the two pins of the Mains/AC Power plug.
  2. Set the Mains/AC Power switch to the "on" position (keep the Mains/AC Power cord unplugged!).
  3. Measure the resistance value between the pins of the Mains/AC Power plug and the metal shielding of the tuner or the aerial connection on the set. The reading should be between 4.5 MΩ and 12 MΩ.
  4. Switch "off" the set, and remove the wire between the two pins of the Mains/AC Power plug.
- Check the cabinet for defects, to prevent touching of any inner parts by the customer.

### 3.2 Warnings

- All ICs and many other semiconductors are susceptible to electrostatic discharges (ESD ▲). Careless handling during repair can reduce life drastically. Make sure that, during repair, you are connected with the same potential as the mass of the set by a wristband with resistance. Keep components and tools also at this same potential.
- Be careful during measurements in the high voltage section.
- Never replace modules or other components while the unit is switched "on".
- When you align the set, use plastic rather than metal tools. This will prevent any short circuits and the danger of a circuit becoming unstable.

### 3.3 Notes

#### 3.3.1 General

- Measure the voltages and waveforms with regard to the chassis (= tuner) ground (⊕), or hot ground (⊖), depending on the tested area of circuitry. The voltages and waveforms shown in the diagrams are indicative. Measure them in the Service Default Mode with a colour bar signal and stereo sound (L: 3 kHz, R: 1 kHz unless stated otherwise) and picture carrier at 475.25 MHz for PAL, or 61.25 MHz for NTSC (channel 3).

- Where necessary, measure the waveforms and voltages with (⊖) and without (⊕) aerial signal. Measure the voltages in the power supply section both in normal operation (⊖) and in stand-by (⊕). These values are indicated by means of the appropriate symbols.

#### 3.3.2 Schematic Notes

- All resistor values are in ohms, and the value multiplier is often used to indicate the decimal point location (e.g. 2K2 indicates 2.2 kΩ).
- Resistor values with no multiplier may be indicated with either an "E" or an "R" (e.g. 220E or 220R indicates 220 Ω).
- All capacitor values are given in micro-farads ( $\mu = \times 10^{-6}$ ), nano-farads ( $n = \times 10^{-9}$ ), or pico-farads ( $p = \times 10^{-12}$ ).
- Capacitor values may also use the value multiplier as the decimal point indication (e.g. 2p2 indicates 2.2 pF).
- An "asterisk" (\*) indicates component usage varies. Refer to the diversity tables for the correct values.
- The correct component values are listed on the Philips Spare Parts Web Portal.

#### 3.3.3 Spare Parts

For the latest spare part overview, consult your Philips Spare Part web portal.

#### 3.3.4 BGA (Ball Grid Array) ICs

##### Introduction

For more information on how to handle BGA devices, visit this URL: <http://www.atyourservice-magazine.com>. Select "Magazine", then go to "Repair downloads". Here you will find information on how to deal with BGA-ICs.

##### BGA Temperature Profiles

For BGA-ICs, you **must** use the correct temperature-profile. Where applicable and available, this profile is added to the IC Data Sheet information section in this manual.

#### 3.3.5 Lead-free Soldering

Due to lead-free technology some rules have to be respected by the workshop during a repair:

- Use only lead-free soldering tin. If lead-free solder paste is required, please contact the manufacturer of your soldering equipment. In general, use of solder paste within workshops should be avoided because paste is not easy to store and to handle.
- Use only adequate solder tools applicable for lead-free soldering tin. The solder tool must be able:
  - To reach a solder-tip temperature of at least 400°C.
  - To stabilize the adjusted temperature at the solder-tip.
  - To exchange solder-tips for different applications.
- Adjust your solder tool so that a temperature of around 360°C - 380°C is reached and stabilized at the solder joint. Heating time of the solder-joint should not exceed ~ 4 sec. Avoid temperatures above 400°C, otherwise wear-out of tips will increase drastically and flux-fluid will be destroyed. To avoid wear-out of tips, switch "off" unused equipment or reduce heat.
- Mix of lead-free soldering tin/parts with leaded soldering tin/parts is possible but PHILIPS recommends strongly **to avoid** mixed regimes. If this cannot be avoided, carefully clear the solder-joint from old tin and re-solder with new tin.

#### 3.3.6 Alternative BOM identification

It should be noted that on the European Service website, "Alternative BOM" is referred to as "Design variant".

The **third digit** in the serial number (example: AG2B033500001) indicates the number of the alternative B.O.M. (Bill Of Materials) that has been used for producing the specific TV set. In general, it is possible that the same TV model on the market is produced with e.g. two different types of displays, coming from two different suppliers. This will then result in sets which have the same CTN (Commercial Type Number; e.g. 28PW9515/12) but which have a different B.O.M. number.

By looking at the third digit of the serial number, one can identify which B.O.M. is used for the TV set he is working with. If the third digit of the serial number contains the number "1" (example: AG1B033500001), then the TV set has been manufactured according to B.O.M. number 1. If the third digit is a "2" (example: AG2B033500001), then the set has been produced according to B.O.M. no. 2. This is important for ordering the correct spare parts!

For the third digit, the numbers 1...9 and the characters A...Z can be used, so in total: 9 plus 26 = 35 different B.O.M.s can be indicated by the third digit of the serial number.

**Identification:** The bottom line of a type plate gives a 14-digit serial number. Digits 1 and 2 refer to the production centre (e.g. SN is Lysomice, RJ is Kobierzyce), digit 3 refers to the B.O.M. code, digit 4 refers to the Service version change code, digits 5 and 6 refer to the production year, and digits 7 and 8 refer to production week (in example below it is 2010 week 10 / 2010 week 17). The 6 last digits contain the serial number.



Figure 3-1 Serial number (example)

### 3.3.7 Board Level Repair (BLR) or Component Level Repair (CLR)

If a board is defective, consult your repair procedure to decide if the board has to be exchanged or if it should be repaired on component level.

If your repair procedure says the board should be exchanged completely, do not solder on the defective board. Otherwise, it cannot be returned to the O.E.M. supplier for back charging!

### 3.3.8 Practical Service Precautions

- **It makes sense to avoid exposure to electrical shock.** While some sources are expected to have a possible dangerous impact, others of quite high potential are of limited current and are sometimes held in less regard.
- **Always respect voltages.** While some may not be dangerous in themselves, they can cause unexpected reactions that are best avoided. Before reaching into a powered TV set, it is best to test the high voltage insulation. It is easy to do, and is a good service precaution.

## 3.4 Abbreviation List

0/6/12	SCART switch control signal on A/V board. 0 = loop through (AUX to TV), 6 = play 16 : 9 format, 12 = play 4 : 3 format
AARA	Automatic Aspect Ratio Adaptation: algorithm that adapts aspect ratio to remove horizontal black bars; keeps the original aspect ratio
ACI	Automatic Channel Installation: algorithm that installs TV channels directly from a cable network by means of a predefined TXT page
ADC	Analogue to Digital Converter
AFC	Automatic Frequency Control: control signal used to tune to the correct frequency
AGC	Automatic Gain Control: algorithm that controls the video input of the feature box
AM	Amplitude Modulation
AP	Asia Pacific
AR	Aspect Ratio: 4 by 3 or 16 by 9
ASF	Auto Screen Fit: algorithm that adapts aspect ratio to remove horizontal black bars without discarding video information
ATSC	Advanced Television Systems Committee, the digital TV standard in the USA
ATV	See Auto TV
Auto TV	A hardware and software control system that measures picture content, and adapts image parameters in a dynamic way
AV	External Audio Video
AVC	Audio Video Controller
AVIP	Audio Video Input Processor
B/G	Monochrome TV system. Sound carrier distance is 5.5 MHz
BDS	Business Display Solutions (iTV)
BLR	Board-Level Repair
BTSC	Broadcast Television Standard Committee. Multiplex FM stereo sound system, originating from the USA and used e.g. in LATAM and AP-NTSC countries
B-TXT	Blue TeleteXT
C	Centre channel (audio)
CEC	Consumer Electronics Control bus: remote control bus on HDMI connections
CL	Constant Level: audio output to connect with an external amplifier
CLR	Component Level Repair
ComPair	Computer aided rePair
CP	Connected Planet / Copy Protection
CSM	Customer Service Mode
CTI	Color Transient Improvement: manipulates steepness of chroma transients
CVBS	Composite Video Blanking and Synchronization
DAC	Digital to Analogue Converter
DBE	Dynamic Bass Enhancement: extra low frequency amplification
DCM	Data Communication Module. Also referred to as System Card or Smartcard (for iTV).
DDC	See "E-DDC"
D/K	Monochrome TV system. Sound carrier distance is 6.5 MHz
DFI	Dynamic Frame Insertion

DFU	Directions For Use: owner's manual		SDI), is a digitized video format used for broadcast grade video.
DMR	Digital Media Reader: card reader		Uncompressed digital component or digital composite signals can be used.
DMSD	Digital Multi Standard Decoding		The SDI signal is self-synchronizing, uses 8 bit or 10 bit data words, and has a maximum data rate of 270 Mbit/s, with a minimum bandwidth of 135 MHz.
DNM	Digital Natural Motion		Institutional TeleVision; TV sets for hotels, hospitals etc.
DNR	Digital Noise Reduction: noise reduction feature of the set	iTV	Last Status; The settings last chosen by the customer and read and stored in RAM or in the NVM. They are called at start-up of the set to configure it according to the customer's preferences
DRAM	Dynamic RAM	LS	Latin America
DRM	Digital Rights Management		Liquid Crystal Display
DSP	Digital Signal Processing		Light Emitting Diode
DST	Dealer Service Tool: special remote control designed for service technicians		Monochrome TV system. Sound carrier distance is 6.5 MHz. L' is Band I, L is all bands except for Band I LG.Philips LCD (supplier)
DTCP	Digital Transmission Content Protection; A protocol for protecting digital audio/video content that is traversing a high speed serial bus, such as IEEE-1394	LATAM	Loudspeaker
DVB-C	Digital Video Broadcast - Cable		Low Voltage Differential Signalling
DVB-T	Digital Video Broadcast - Terrestrial	LCD	Mega bits per second
DVD	Digital Versatile Disc	LED	Monochrome TV system. Sound carrier distance is 4.5 MHz
DVI(-d)	Digital Visual Interface (d= digital only)	L/L'	Part of a set of international standards related to the presentation of multimedia information, standardised by the Multimedia and Hypermedia Experts Group. It is commonly used as a language to describe interactive television services
E-DDC	Enhanced Display Data Channel (VESA standard for communication channel and display). Using E-DDC, the video source can read the EDID information form the display.	LPL	Microprocessor without Interlocked Pipeline-Stages; A RISC-based microprocessor
EDID	Extended Display Identification Data (VESA standard)	LS	Matrix Output Processor
EEPROM	Electrically Erasable and Programmable Read Only Memory	LVDS	Metal Oxide Silicon Field Effect Transistor, switching device
EMI	Electro Magnetic Interference	Mbps	Motion Pictures Experts Group
EPG	Electronic Program Guide	M/N	Multi Platform InterFace
EPLD	Erasable Programmable Logic Device	MHEG	MUTE Line
EU	Europe		MUTE Line
EXT	EXternal (source), entering the set by SCART or by cinches (jacks)		Mainstream TV: TV-mode with Consumer TV features enabled (iTV)
FDS	Full Dual Screen (same as FDW)	MIPS	Not Connected
FDW	Full Dual Window (same as FDS)		Near Instantaneous Compounded Audio Multiplexing. This is a digital sound system, mainly used in Europe.
FLASH	FLASH memory	MOP	Negative Temperature Coefficient, non-linear resistor
FM	Field Memory or Frequency Modulation	MOSFET	National Television Standard Committee. Color system mainly used in North America and Japan. Color carrier NTSC M/N= 3.579545 MHz, NTSC 4.43= 4.433619 MHz (this is a VCR norm, it is not transmitted off-air)
FPGA	Field-Programmable Gate Array		Non-Volatile Memory: IC containing TV related data such as alignments
FTV	Flat TeleVision	MPEG	Open Circuit
Gb/s	Giga bits per second	MPIF	Over the Air Download. Method of software upgrade via RF transmission.
G-TXT	Green TeleteXT	MUTE	Upgrade software is broadcasted in TS with TV channels.
H	H_sync to the module	MTV	On screen display Teletext and Control; also called Artistic (SAA5800)
HD	High Definition		Project 50: communication protocol between TV and peripherals
HDD	Hard Disk Drive	NC	Phase Alternating Line. Color system mainly used in West Europe (colour carrier = 4.433619 MHz) and South America (colour carrier
HDCP	High-bandwidth Digital Content Protection: A "key" encoded into the HDMI/DVI signal that prevents video data piracy. If a source is HDCP coded and connected via HDMI/DVI without the proper HDCP decoding, the picture is put into a "snow vision" mode or changed to a low resolution. For normal content distribution the source and the display device must be enabled for HDCP "software key" decoding.	NICAM	
HDMI	High Definition Multimedia Interface	NTC	
HP	HeadPhone	NTSC	
I	Monochrome TV system. Sound carrier distance is 6.0 MHz	NVM	
I <sup>2</sup> C	Inter IC bus	O/C	
I <sup>2</sup> D	Inter IC Data bus	OSD	
I <sup>2</sup> S	Inter IC Sound bus	OAD	
IF	Intermediate Frequency		
IR	Infra Red	OTC	
IRQ	Interrupt Request	P50	
ITU-656	The ITU Radio communication Sector (ITU-R) is a standards body subcommittee of the International Telecommunication Union relating to radio communication. ITU-656 (a.k.a.	PAL	

	PAL M = 3.575612 MHz and PAL N = 3.582056 MHz)	SVGA	800 × 600 (4:3)
PCB	Printed Circuit Board (same as "PWB")	SVHS	Super Video Home System
PCM	Pulse Code Modulation	SW	Software
PDP	Plasma Display Panel	SWAN	Spatial temporal Weighted Averaging Noise reduction
PFC	Power Factor Corrector (or Pre- conditioner)	SXGA	1280 × 1024
PIP	Picture In Picture	TFT	Thin Film Transistor
PLL	Phase Locked Loop. Used for e.g. FST tuning systems. The customer can give directly the desired frequency	THD	Total Harmonic Distortion
POD	Point Of Deployment: a removable CAM module, implementing the CA system for a host (e.g. a TV-set)	TMDS	Transmission Minimized Differential Signalling
POR	Power On Reset, signal to reset the uP	TS	Transport Stream
PSDL	Power Supply for Direct view LED backlight with 2D-dimming	TXT	TeleteXT
PSL	Power Supply with integrated LED drivers	TXT-DW	Dual Window with TeleteXT
PSLS	Power Supply with integrated LED drivers with added Scanning functionality	UI	User Interface
PTC	Positive Temperature Coefficient, non-linear resistor	uP	Microprocessor
PWB	Printed Wiring Board (same as "PCB")	UXGA	1600 × 1200 (4:3)
PWM	Pulse Width Modulation	V	V-sync to the module
QRC	Quasi Resonant Converter	VESA	Video Electronics Standards Association
QTNR	Quality Temporal Noise Reduction	VGA	640 × 480 (4:3)
QVCP	Quality Video Composition Processor	VL	Variable Level out: processed audio output toward external amplifier
RAM	Random Access Memory	VSB	Vestigial Side Band; modulation method
RGB	Red, Green, and Blue. The primary color signals for TV. By mixing levels of R, G, and B, all colors (Y/C) are reproduced.	WYSIWYR	What You See Is What You Record: record selection that follows main picture and sound
RC	Remote Control	WXGA	1280 × 768 (15:9)
RC5 / RC6	Signal protocol from the remote control receiver	XTAL	Quartz crystal
RESET	RESET signal	XGA	1024 × 768 (4:3)
ROM	Read Only Memory	Y	Luminance signal
RSDS	Reduced Swing Differential Signalling data interface	Y/C	Luminance (Y) and Chrominance (C) signal
R-TXT	Red TeleteXT	YPbPr	Component video. Luminance and scaled color difference signals (B-Y and R-Y)
SAM	Service Alignment Mode	YUV	Component video
S/C	Short Circuit		
SCART	Syndicat des Constructeurs d'Appareils Radiorécepteurs et Téléviseurs		
SCL	Serial Clock I <sup>2</sup> C		
SCL-F	CLock Signal on Fast I <sup>2</sup> C bus		
SD	Standard Definition		
SDA	Serial Data I <sup>2</sup> C		
SDA-F	DAta Signal on Fast I <sup>2</sup> C bus		
SDI	Serial Digital Interface, see "ITU-656"		
SDRAM	Synchronous DRAM		
SECAM	SEquence Couleur Avec Mémoire. Colour system mainly used in France and East Europe. Colour carriers = 4.406250 MHz and 4.250000 MHz		
SIF	Sound Intermediate Frequency		
SMPS	Switched Mode Power Supply		
SoC	System on Chip		
SOG	Sync On Green		
SOPS	Self Oscillating Power Supply		
SPI	Serial Peripheral Interface bus; a 4- wire synchronous serial data link standard		
S/PDIF	Sony Philips Digital InterFace		
SRAM	Static RAM		
SRP	Service Reference Protocol		
SSB	Small Signal Board		
SSC	Spread Spectrum Clocking, used to reduce the effects of EMI		
STB	Set Top Box		
STBY	STand-BY		



## 4. Mechanical Instructions

Index of this chapter:

[4.1 Cable Dressing](#)

[4.2 Service Positions](#)

[4.3 Assembly/Panel Removal](#)

[4.4 Set Re-assembly](#)

Notes:

- Figures below can deviate slightly from the actual situation, due to the different set executions.

### 4.1 Cable Dressing

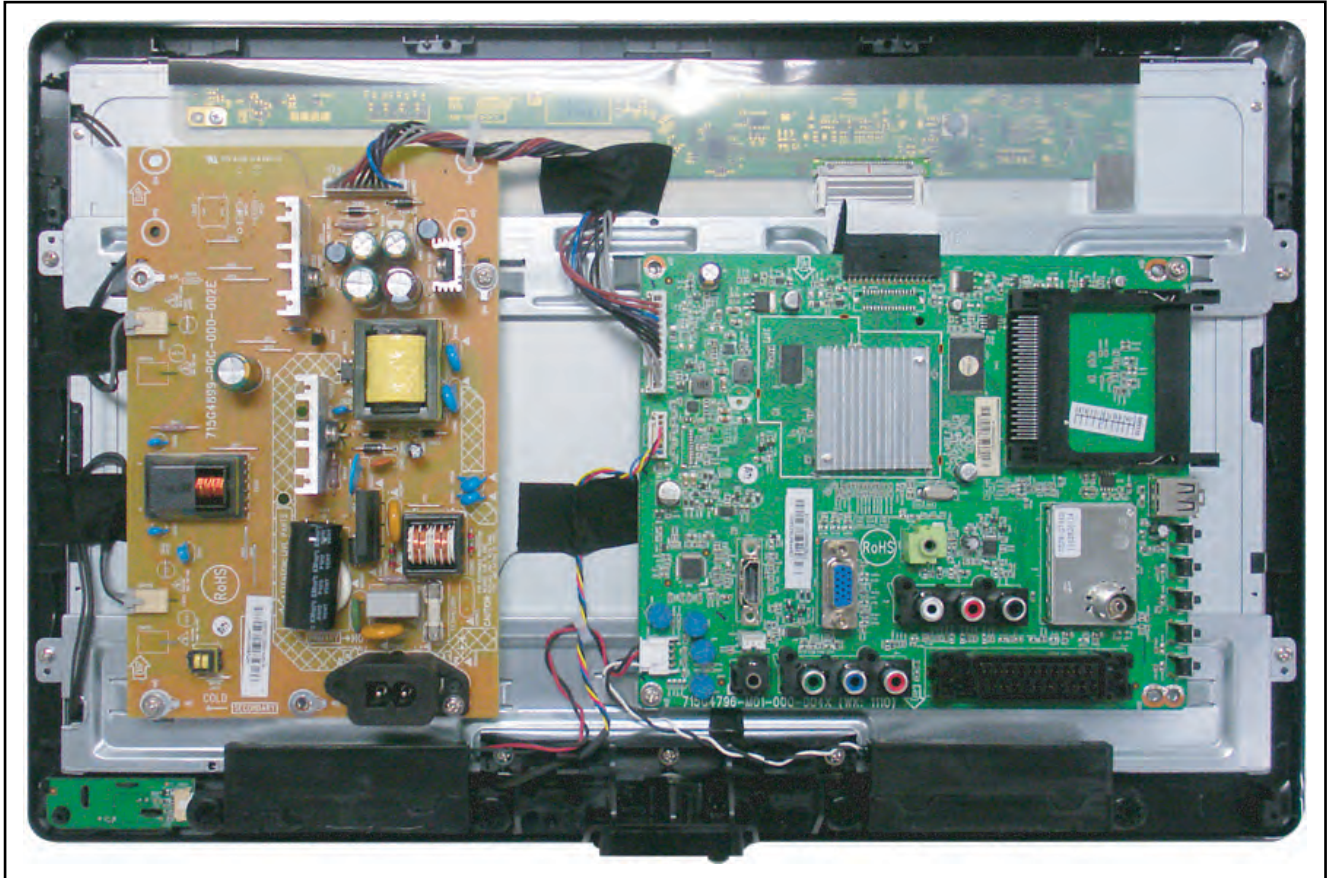

19120\_100\_110511.eps  
110511

Figure 4-1 Cable dressing 19" Golden horse

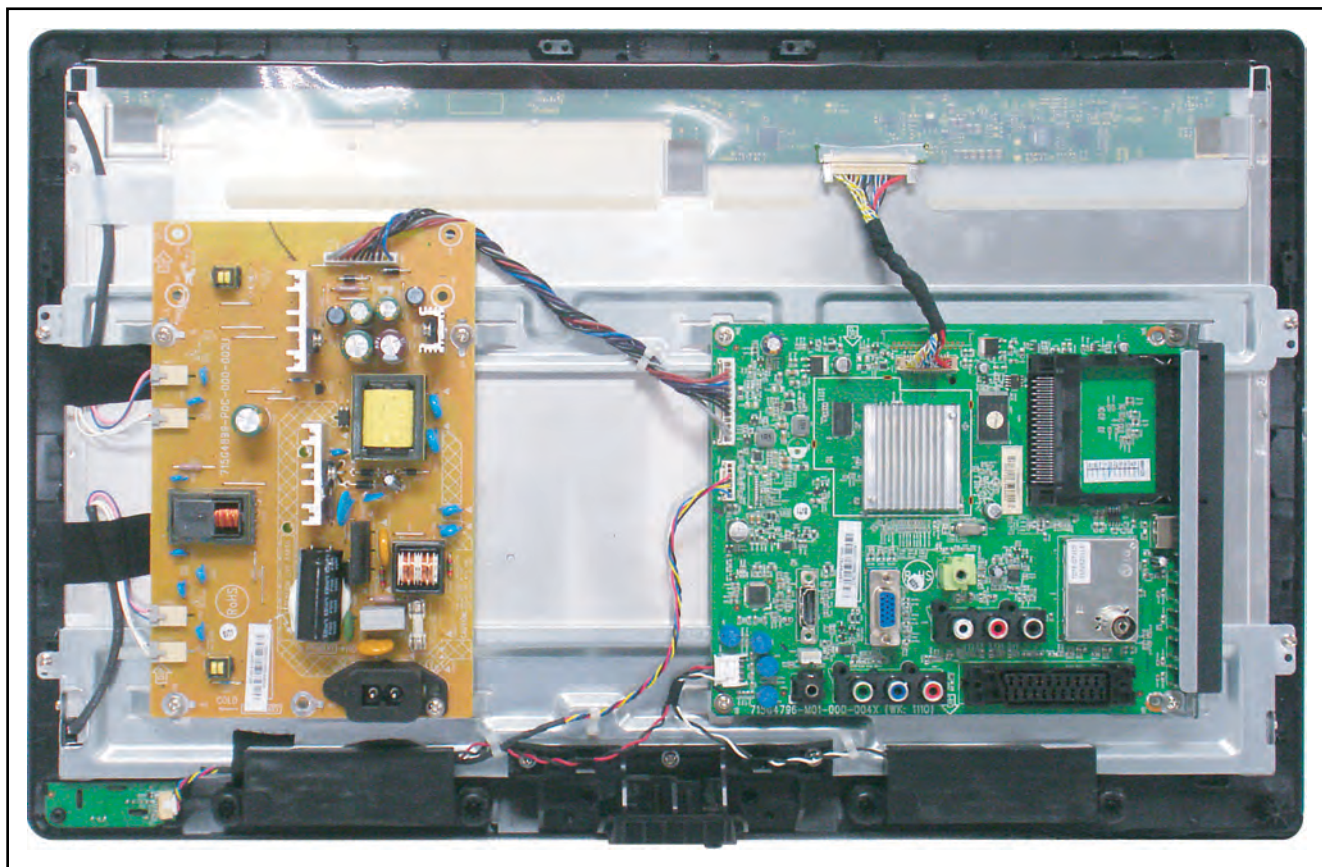

19120\_101\_110511.eps  
110511

Figure 4-2 Cable dressing 22" Golden horse



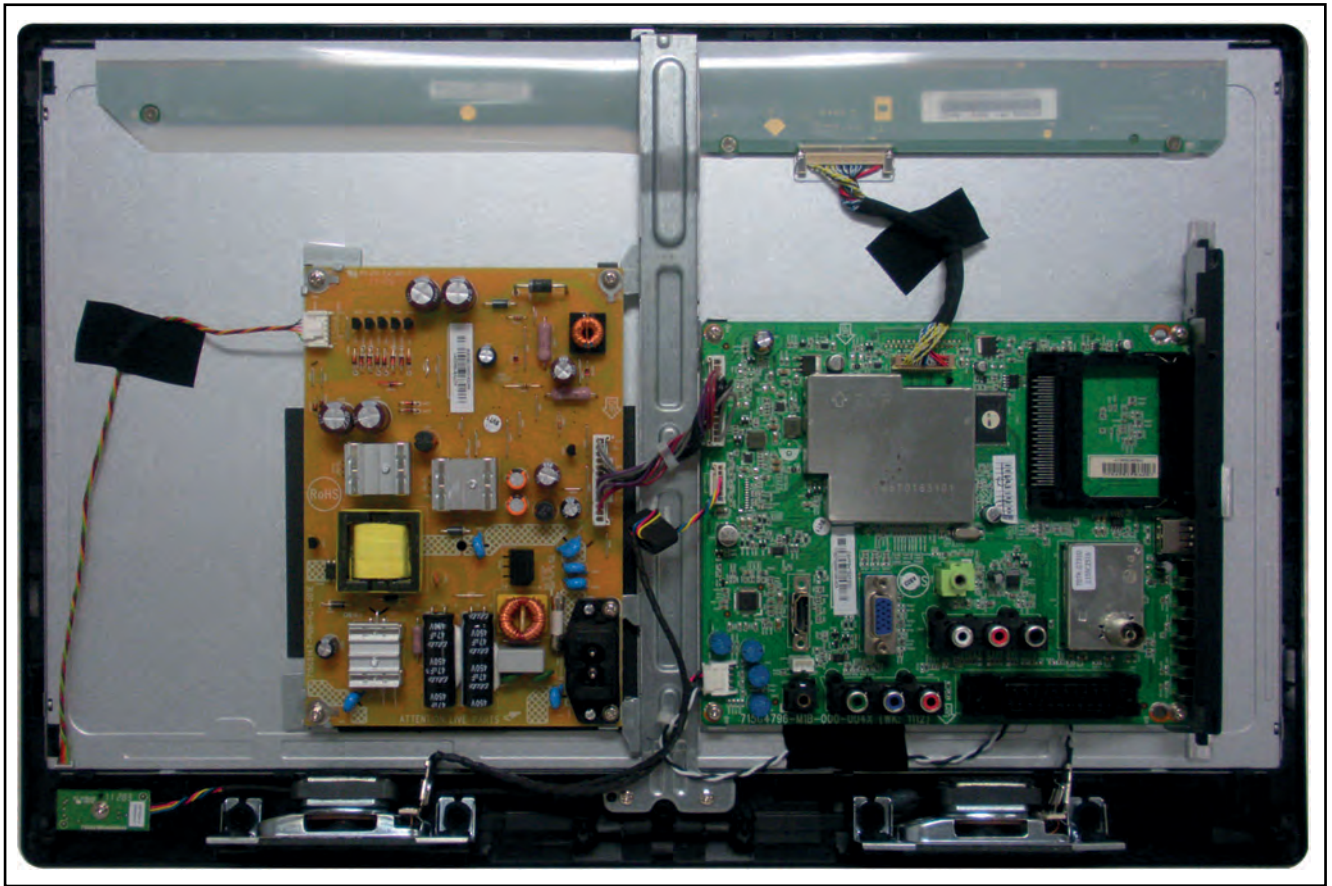

19121\_101\_110914.eps  
110914

Figure 4-3 Cable dressing 22" Spot Deal

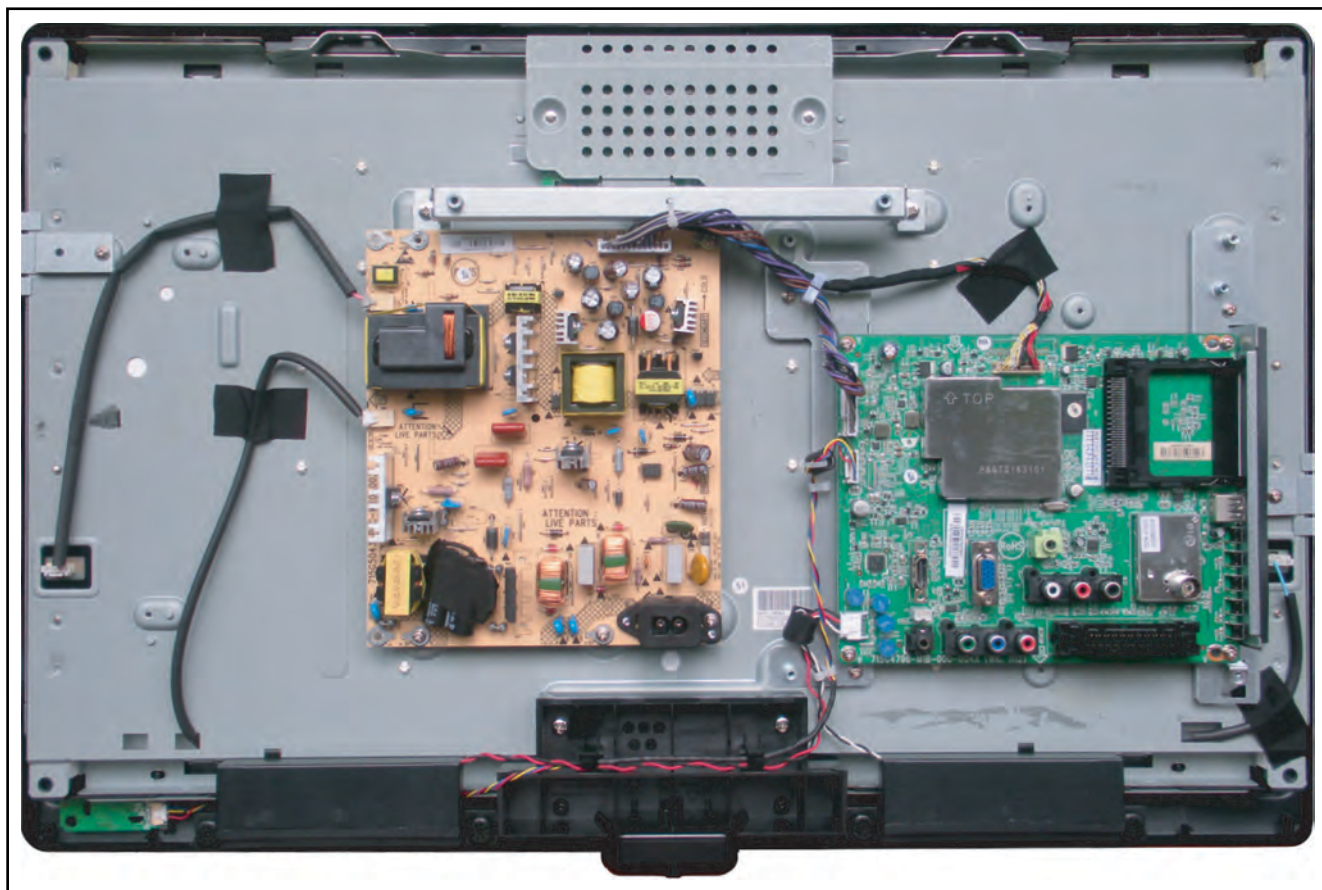

19120\_102\_110527.eps  
110527

Figure 4-4 Cable dressing 26" Golden horse



19121\_100\_110913.eps  
110913

Figure 4-5 Cable dressing 32" Spot Deal

## 4.2 Service Positions

For easy servicing of a TV set, the set should be put face down on a soft flat surface, foam buffers or other specific workshop tools. Ensure that a stable situation is created to perform measurements and alignments. When using foam bars take care that these always support the cabinet and **never** only the display. **Caution:** Failure to follow these guidelines can seriously damage the display!

Ensure that ESD safe measures are taken.

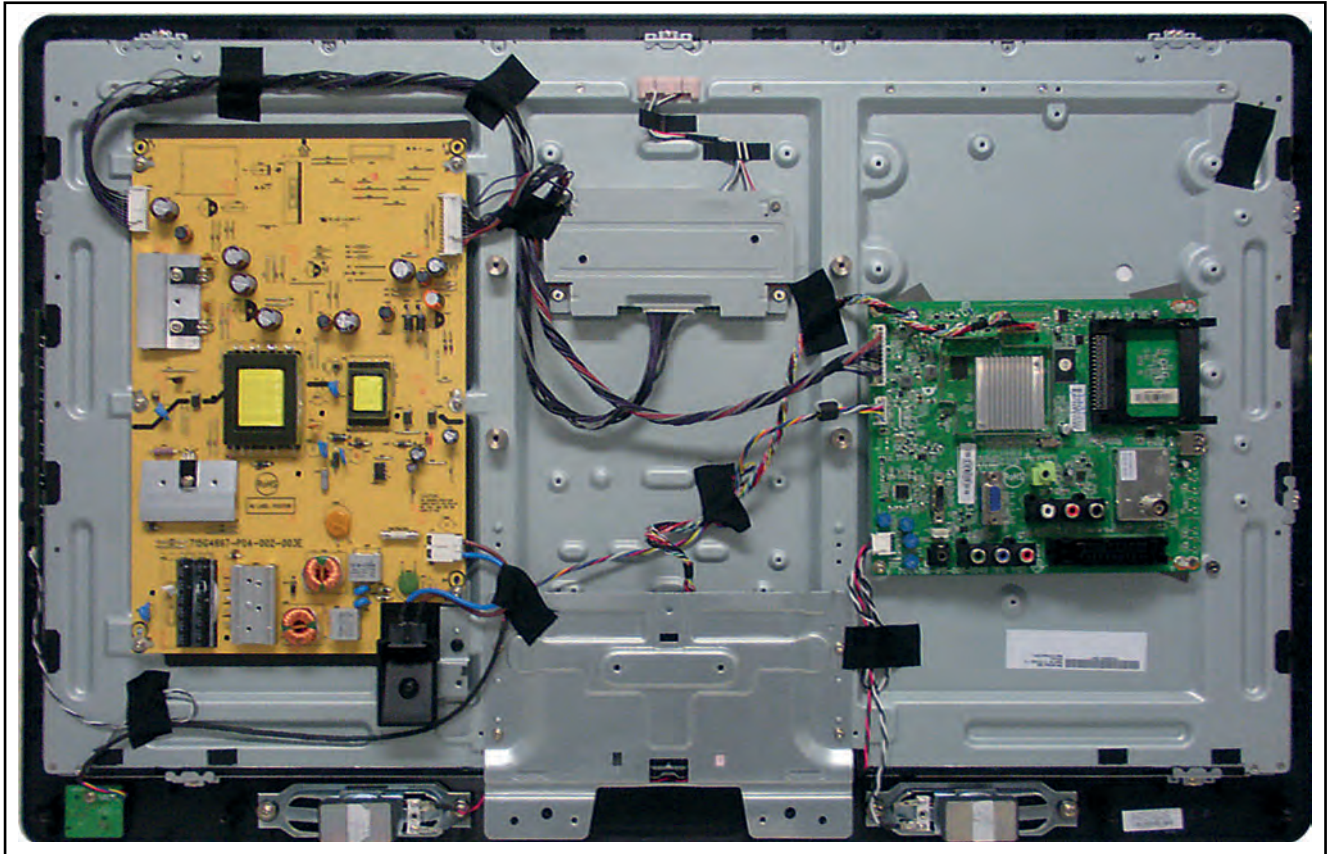
## 4.3 Assembly/Panel Removal

Instructions below apply to the 22PFL3606H/12, but will be similar for other models.

### 4.3.1 Rear Cover

Refer to [Figure 4-6](#) for details.

**Warning:** Disconnect the mains power cord before removing the rear cover.

1. Remove the fixation screws [1] and [2] that secure the rear cover. Refer to [Figure 4-6](#) for details.
2. At the indicated areas [3] the cover is secured by clips. Be very careful with releasing those.
3. Lift the rear cover from the TV. Make sure that wires and flat foils are not damaged while lifting the rear cover from the set.

19120\_103\_110512.eps  
110526

Figure 4-6 Rear cover removal

#### 4.3.2 Small Signal Board (SSB)

Refer to [Figure 4-7](#) for details.

**Caution:** it is mandatory to remount all different screws at their original position during re-assembly. Failure to do so may result in damaging the SSB.

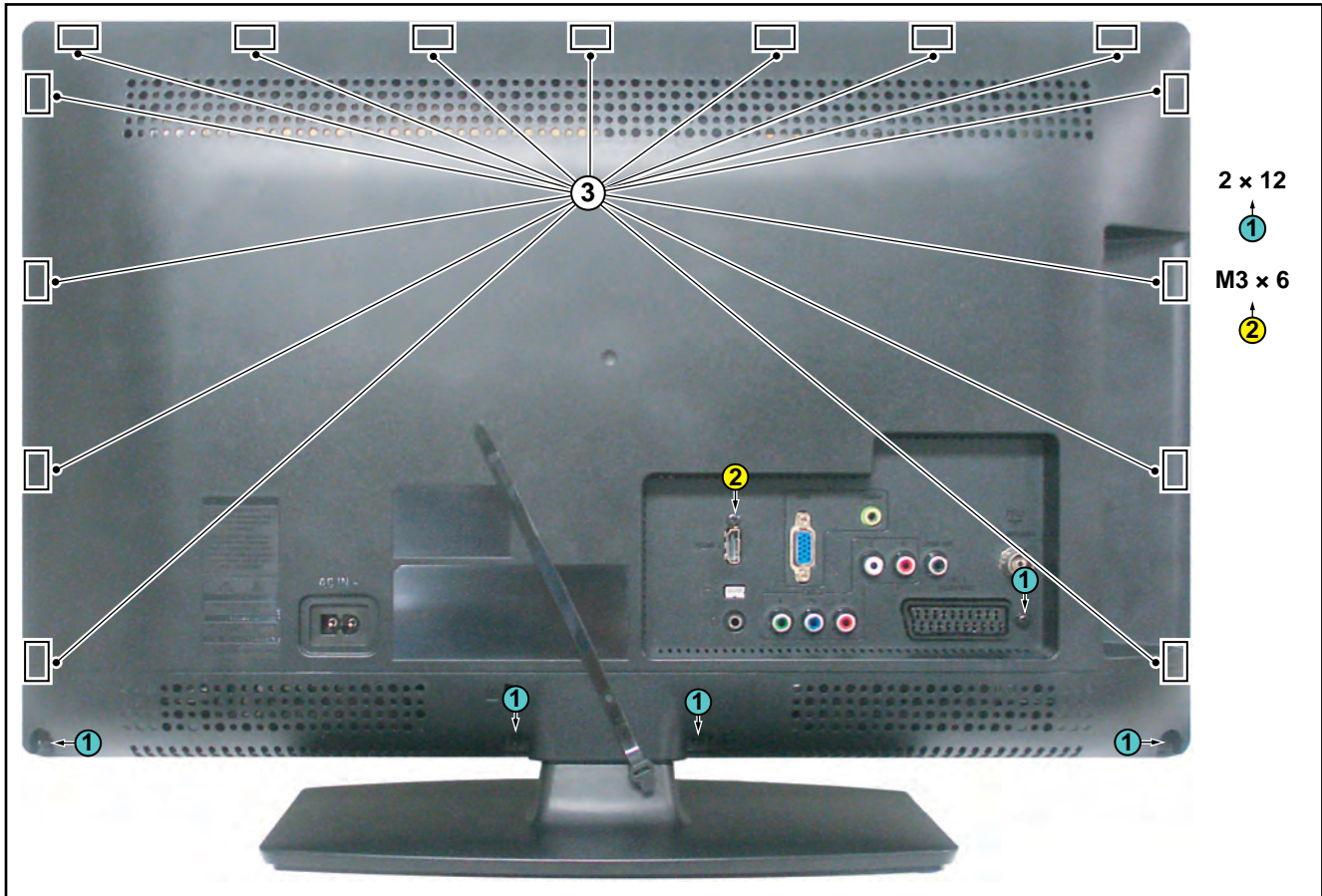
1. Release the clips from both the LVDS cables/Flat Foils connectors that connect to the SSB [1].  
**Caution:** be careful, as these are very fragile connectors!
2. Release the clamps and unplug all other connectors [2].
3. Remove all fixation screws [3] from the SSB.
4. Take out of the SSB. Refer to [Figure 4-7](#) for details.

19120\_104\_110512.eps  
110530

Figure 4-7 SSB removal

#### 4.3.3 Power Supply Unit (PSU)

**Caution:** it is mandatory to remount all different screws at their original position during re-assembly. Failure to do so may result in damaging the PSU.

1. Release the Power board cables from their clamps.
2. Unplug power connectors from the SSB, as it is not unpluggable at the PSU itself (soldered connector).
3. Unplug all other connectors from the PSU.
4. Remove all fixation screws from the PSU.
5. The PSU can be taken out of the set now.

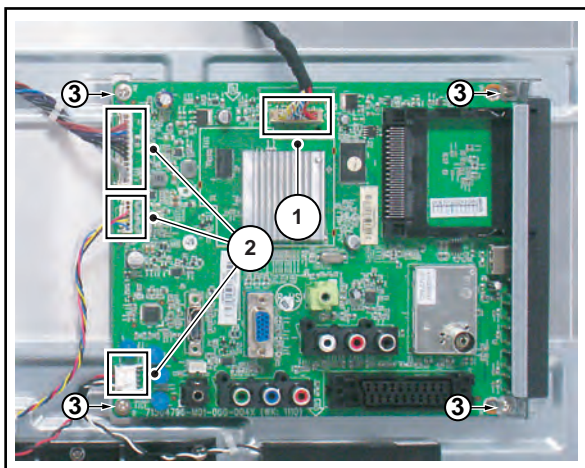
#### 4.3.4 Speakers

1. Unplug speaker connector from the SSB.
2. Release speaker cables from the clamps.
3. Take the speakers out.

When defective, replace both units.

#### 4.3.5 IR/LED Board

1. Unplug the connectors from the IR/LED board.
2. Release the clips that hold the board and take it out from the bezel.

When defective, replace both units.

#### 4.3.6 LCD Panel 19"/22"

1. Release the LVDS connector from the LCD panel.
  2. Release the lamp connectors from the PSU.
  3. Take out the speakers, as described earlier.
  4. Remove the IR/LED board as described earlier.
  5. Release all tapes that fit cables to the back side of the LCD panel.
  6. Remove all fixation screws of the sub frames on the sides of the LCD panel.
  7. Lift the sub frames, together with the mounted panels from the LCD panel and put it aside.
  8. Lift the LCD panel from the front bezel.
- When defective, replace the whole unit.

#### 4.3.7 LCD Panel 26"

1. Release the LVDS connector from the LCD panel.
  2. Release the lamp connectors from the PSU.
  3. Take out the speakers, as described earlier.
  4. Remove the IR/LED board as described earlier.
  5. Remove the PSU, as described earlier.
  6. Remove the SSB, as described earlier.
  7. Release all tapes that fit cables to the back side of the LCD panel.
  8. Remove all fixation screws of the sub frames and take out these frames.
  9. Remove all fixation screws of the clamps on the sides of the LCD panel and take out these clamps.
  10. Lift the LCD panel from the front bezel.
- When defective, replace the whole unit.

### 4.4 Set Re-assembly

To re-assemble the whole set, execute all processes in reverse order.

**Notes:**

- While re-assembling, make sure that all cables are placed and connected in their original position. See [Figure 4-1](#) to [Figure 4-5](#).
- Pay special attention not to damage the EMC foams on the SSB shields. Ensure that EMC foams are mounted correctly.



# 5. Service Modes, Error Codes, and Fault Finding

**Index of this chapter:**

- [5.1 Test Points](#)
- [5.2 Service Modes](#)
- [5.3 Stepwise Start-up](#)
- [5.4 Service Tools](#)
- [5.5 Software Upgrading](#)
- [5.6 Error Codes](#)
- [5.7 The Blinking LED Procedure](#)
- [5.8 Fault Finding and Repair Tips](#)

## 5.1 Test Points

As most signals are digital, it will be difficult to measure waveforms with a standard oscilloscope. However, several key ICs are capable of generating test patterns, which can be controlled via ComPair. In this way it is possible to determine which part is defective.

Perform measurements under the following conditions:

- Service Default Mode.
- Video: Colour bar signal.
- Audio: 3 kHz left, 1 kHz right.

## 5.2 Service Modes

The Service Mode feature is split into four parts:

- Service Default Mode (SDM).
- Service Alignment Mode (SAM).
- Customer Service Mode (CSM).
- Computer Aided Repair Mode (ComPair).

**Table 5-1 Service mode overview**

Service Modes	Description
SAM	Service alignment mode
SDM	Service default Mode
CSM	Customer Service Mode, a 3-page compact status overview of the set. These pages will be written to a dump file on a USB memory stick upon entering CSM-mode
USB software upgradeable	Software upgrading of flash memories MTK-chips MT5366 can be done via USB. The main software can be upgraded via Autorun.upg
NVM-Editor in SAM	NVM-editor provides address and data field editing
Service Data	New Service data in SAM for CTN, Prod. no., and 12NC programming with a virtual keyboard
USB copy/paste in SAM	Channel list, NVM data, Readable info, EDID
UART logging	UART logging is available, however no specification of the output, according to MTK definition.
Blind SAM	Remote control sequence "062598" + "Menu" + "Panel code"
Clear Buffer	RC sequence "062599" + "OK" or via SAM

SDM and SAM offer features, which can be used by the Service engineer to repair/align a TV set. Some features are:

- A pre-defined situation to ensure measurements can be made under uniform conditions (SDM).
- Activates the blinking LED procedure for error identification when no picture is available (SDM).
- Make alignments (e.g. White Tone), reset the error buffer (SAM).

- Display information ("SDM" or "SAM" indication in upper right corner of screen, error buffer, software version, operating hours, options and option codes, sub menus).

CSM is a Service Mode that can be enabled by the consumer. CSM displays diagnosis information, which the customer can forward to the dealer or call centre. In CSM mode, "CSM", is displayed in the top right corner of the screen. The information provided in CSM and the purpose of CSM is to:

- Increase the home repair hit rate.
- Decrease the number of nuisance calls.
- Solve customer problems without home visit.

ComPair Mode is used for communication between a computer and a TV on I<sup>2</sup>C /UART level and can be used by a Service engineer to quickly diagnose the TV set by reading out error codes, read and write in NVMs, communicate with ICs and the μP (PWM, registers, etc.), and by making use of a fault finding database. It will also be possible to up and download the software of the TV set via I<sup>2</sup>C with help of ComPair. To do this, ComPair has to be connected to the TV set via the ComPair connector, which will be accessible through the rear of the set (without removing the rear cover).

**Note:** For the new model range, a new remote control (RC) is used with some renamed buttons. This has an impact on the activation of the Service modes. For instance the old "MENU" button is now called "HOME" (or is indicated by a "house" icon).

### 5.2.1 General

Next items are applicable to all Service Modes or are general.

#### Life Timer

During the life time cycle of the TV set, a timer is kept (called "Op. Hour"). It counts the normal operation hours (not the Stand-by hours). The actual value of the timer is displayed in SDM and SAM in a decimal value. Every two soft-resets increase the hour by + 1. Stand-by hours are not counted.

#### Software Identification, Version, and Cluster

The software ID, version, and cluster will be shown in the main menu display of SDM, SAM, and CSM.

The screen will show: "AAAAAB X.YY", where:

- AAAAA is the chassis name.
- B is the region indication: E = Europe, A = AP/China, U = NAFTA, L = LATAM.
- X is the main version number: this is updated with a major change of specification (incompatible with the previous software version). Numbering will go from 01 - 99 and AA - ZZ.
  - If the main version number changes, the new version number is written in the NVM.
  - If the main version number changes, the default settings are loaded.
- YY is the sub version number: this is updated with a minor change (backwards compatible with the previous versions). Numbering will go from 00 - 99.
  - If the sub version number changes, the new version number is written in the NVM.
  - If the NVM is fresh, the software identification, version, and cluster will be written to NVM.

### 5.2.2 Service Default Mode (SDM)

#### Purpose

Set the TV in SDM mode in order to be able to create a predefined setting for measurements to be made. In this platform, a simplified SDM is introduced (without protection override and without tuning to a predefined frequency).

**Specifications**

- Set linear video and audio settings to 50%, but volume to 25%. Stored user settings are not affected.
- All service-unfriendly modes (if present) are disabled, since they interfere with diagnosing/repairing a set. These service unfriendly modes are:
  - (Sleep) timer.
  - Blue mute/Wall paper.
  - Auto switch “off” (when there is no “ident” signal).
  - Hotel or hospital mode.
  - Child lock or parental lock (manual or via V-chip).
  - Skipping, blanking of “Not favourite”, “Skipped” or “Locked” presets/channels.
  - Automatic storing of Personal Preset or Last Status settings.
  - Automatic user menu time-out (menu switches back/OFF automatically).
  - Auto Volume levelling (AVL).

**How to Activate SDM**

To activate SDM, use the following methods:

- Press the following key sequence on the RC transmitter: “062596”, directly followed by the “MENU” button.
 

**Note:** It is possible that, together with the SDM, the main menu will appear. To switch it “off”, push the “MENU” button again.

After activating this mode, “SDM” will appear in the upper left corner of the screen (when a picture is available).

**On Screen Menu**

After activating SDM, the following items are displayed, with “SDM” in the upper right corner of the screen to indicate that the television is in Service Default Mode. Menu items and explanation:

- **xxxxx** Operating hours (in decimal).
- **AAAAAB X.YY** See paragraph Software Identification, Version, and Cluster for the SW name definition.
- **ERR** Shows all errors detected since the last time the buffer was erased in format <xxx> <xxx> <xxx> <xxx> <xxx> (five errors possible).
- **OP** Used to read-out the option bytes. Ten codes (in two rows) are possible.

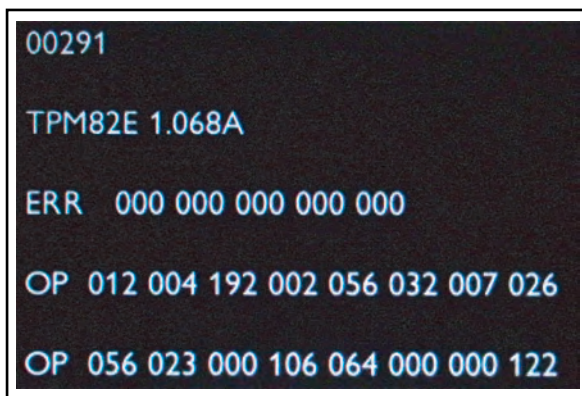

19120\_200\_110512.eps  
110512

Figure 5-1 SDM menu

**How to Navigate**

As this mode is read only, there is not much to navigate. To switch to other modes, use one of the following methods:

- Command MENU from the user remote will enter the normal user menu (brightness, contrast, colour, etc...) with “SDM” OSD remaining, and pressing MENU key again will return to the last status of SDM again.
- To prevent the OSD from interfering with measurements in SDM, command “OSD” or “i+” (“STATUS” or “INFO” for NAFTA and LATAM) from the user remote will toggle the OSD “on/off” with “SDM” OSD remaining always “on”.

- Press the following key sequence on the remote control transmitter: “062596” directly followed by the OK button to switch to SAM (do not allow the display to time out between entries while keying the sequence). Remarks: new RC will not have I+ button, but function still remains.

**How to Exit SDM**

- Switch the set to Stand-by, by pressing the standby button on the remote control transmitter or on the television set.
- Via a standard customer RC-transmitter: key in “00”-sequence.
 

**Note:** If the TV is switched “off” by a power interrupt while in SDM, the TV will show up in the last status of SDM menu as soon as the power is supplied again. The error buffer will not be cleared.

**5.2.3 Service Alignment Mode (SAM)**

**Purpose**

- To modify the NVM.
- To display/clear the error code buffer.
- To perform alignments.

**Specifications**

- Operation hours counter (maximum five digits displayed).
- Software version, error codes, and option settings display.
- Error buffer clearing.
- Option settings.
- Software alignments (White Tone).
- NVM Editor.
- Set screen mode to full screen (all content is visible).

**How to Activate SAM**

To activate SAM, use one of the following methods:

- Press the following key sequence on the remote control transmitter: “062596”, directly followed by the “OK” button. Do not allow the display to time out between entries while keying the sequence.
- Or via ComPair.

After entering SAM, the following items are displayed, with “SAM” in the upper right corner of the screen to indicate that the television is in Service Alignment Mode.

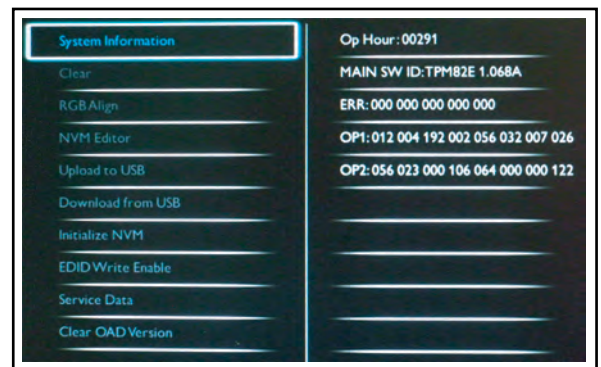

19120\_201\_110512.eps  
110512

Figure 5-2 Example of SAM

Table 5-2 SAM mode overview

Main Menu	Sub-menu 1	Sub-menu 2	Description
System Information	Op Hour		This represents the life timer. The timer counts normal operation hours, but does not count Stand-by hours.
	Main SW ID	e.g. "TPM82E 1.068A"	See paragraph Software Identification, Version, and Cluster for the SW name definition.
	ERR	e.g. "000 000 000 000 000"	Shows all errors detected since the last time the buffer was erased. Five errors possible.
	OP1	e.g. "012 004 192 002 156 032 007 026"	Option code is hard coded in SW, it cannot be edited in SAM mode.
	OP2	e.g. "056 023 000 106 064 000 000 122"	Only to show in SAM system information.
Clear	Press [OK] to clean the Error Codes immediately		Erases the contents of the error buffer. Select this menu item and press the MENU RIGHT key on the remote control. The content of the error buffer is cleared.
RGB Align	Warm	R Gain	To align the White Tone. See paragraph 6.3 Software Alignments in the Alignments section for a detailed description
		G Gain	
		B Gain	
	Normal	R Gain	
		G Gain	
		B Gain	
	Cool	R Gain	
		G Gain	
		B Gain	
	Store		Store the RGB value
NVM editor	Address		Select and fill the NVM address
	Value		Select and fill the NVM value
	Store		Store the value in the address
Upload to USB	Copy Channel List to USB		To upload several settings from the TV to an USB stick
	Copy NVM to USB		
	Copy Readable Info to USB		
	Copy Edid to USB		
Download from USB	Copy Channel List from USB		To download several settings from the USB stick to the TV
	Copy NVM from USB		
	Copy Readable Info from USB		
	Copy Edid from USB		
Initialize NVM	Press [OK] to Initialize NVM immediately		To initialize a (corrupted) NVM. Be careful, this will erase all settings.
EDID Write Enable	Press [OK] to enable EDID writable immediately		Enable EDID writable
Service Data	Type Number	Press [OK] use key pad edit type number immediately	Use Key pad to edit several service data
	Production Number	Press [OK] use key pad edit production number immediately	
	12NC SSB	Press [OK] use key pad edit SSB immediately	
	12NC PSU	Press [OK] use key pad edit PSU immediately	
	12NC Display	Press [OK] use key pad edit display immediately	
Clear OAD Version	Press [OK] to clean OAD Version immediately		Clean OAD Version

### How to Navigate

- In the SAM menu, select menu items with the UP/DOWN keys on the remote control transmitter. The selected item will be indicated. When not all menu items fit on the screen, use the UP/DOWN keys to display the next/previous menu items.
- With the "LEFT/RIGHT" keys, it is possible to:
  - (De) activate the selected menu item.
  - (De) activate the selected sub menu.
  - Change the value of the selected menu item.
- When you press the MENU button twice while in top level SAM, the set will switch to the normal user menu (with the SAM mode still active in the background). To return to the SAM menu press the MENU button.
- The "INFO [+]" key from the user remote will toggle the OSD "on/off" with "SAM" OSD remaining always "on".
- Press the following key sequence on the remote control transmitter: i062596i directly followed by the MENU button to switch to SDM (do not allow the display to time out between entries while keying the sequence). Remarks: new RC will not have I+ button, but function still remain.

### How to Store SAM Settings

To store the settings changed in SAM mode (except the RGB ALIGN settings), leave the top level SAM menu by using the POWER button on the remote control transmitter or the

television set. The mentioned exceptions must be stored separately via the STORE button.

### How to Exit SAM

Use one of the following methods:

- Switch the set to STANDBY by pressing the mains button on the remote control transmitter or the television set.
- Via a standard RC-transmitter, key in "00" sequence.

**Note:** When the TV is switched "off" by a power interrupt while in SAM, the TV will show up in "normal operation mode" as soon as the power is supplied again. The error buffer will not be cleared.

### 5.2.4 Customer Service Mode (CSM)

#### Purpose

The Customer Service Mode shows error codes and information on the TV's operation settings. The call centre can instruct the customer (by telephone) to enter CSM in order to identify the status of the set. This helps the call centre to diagnose problems and failures in the TV set before making a service call.

The CSM is a read-only mode; therefore, modifications are not possible in this mode.

**Specifications**

- Ignore "Service unfriendly modes".
- Line number for every line (to make CSM language independent).
- Set the screen mode to full screen (all contents on screen is visible).
- After leaving the Customer Service Mode, the original settings are restored.
- Possibility to use "CH+" or "CH-" for channel surfing, or enter the specific channel number on the RC.

**How to Activate CSM**

To activate CSM, press the following key sequence on a standard remote control transmitter: "123654" (do not allow the display to time out between entries while keying the sequence). After entering the Customer Service Mode, the following items are displayed.

**Note:** Activation of the CSM is only possible if there is no (user) menu on the screen!



19120\_202\_110512.eps  
110512

**Figure 5-3 CSM Menu [1/3]**

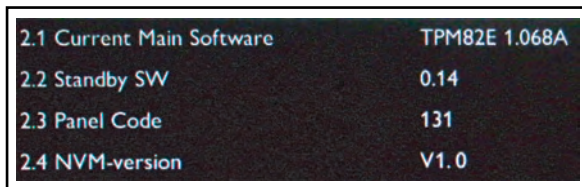

19120\_203\_110512.eps  
110512

**Figure 5-4 CSM Menu [2/3]**



19120\_204\_110512.eps  
110512

**Figure 5-5 CSM Menu [3/3]**

**Contents of CSM**

- **1.1 Set Type** This information is very helpful for a helpdesk/workshop as reference for further diagnosis. In this way, it is not necessary for the customer to look at the rear of the TV-set. Note that if an NVM is replaced or is initialized after corruption, this set type has to be re-written to NVM.
- **1.2 Production code** Displays the production code (the serial number) of the TV. Note that if an NVM is replaced or is initialized after corruption, this production code has to be re-written to NVM.
- **1.3 Installation date** Indicates the date of the first installation of the TV. This date is acquired via time extraction.

- **1.4 Option Code 1** Gives the option codes of option group 1 as set in SAM.
- **1.5 Option Code 2** Gives the option codes of option group 2 as set in SAM.
- **1.6 SSB** Gives an identification of the SSB as stored in NVM. Note that if an NVM is replaced or is initialized after corruption, this identification number has to be re-written to NVM. This identification number is the 12NC number of the SSB.
- **1.7 Display** Displays the 12NC of the NVM.
- **1.8 PSU** Displays the 12NC of the PSU.
- **2.1 Current Main SW** Displays the built-in main software version. In case of field problems related to software, software can be upgraded. As this software is consumer upgradeable, it will also be published on the Internet.
- **2.2 Standby SW** Displays the built-in stand-by processor software version. Upgrading this software will be possible via USB.
- **2.3 Panel Code** Displays the Display Code number.
- **2.4 NVM version** Detects and displays NVM version.
- **3.1 Signal Quality/Present** Analogue/digital signal strength.
- **3.2 Child lock** Not active / active. This is a combined item for locks. If any lock (channel lock, parental lock) is active, the item shall show "active".
- **3.3 HDCP keys** Indicates if the HDMI keys (or HDCP keys) are valid or not. In case these keys are not valid and the customer wants to make use of the HDMI functionality, the SSB has to be replaced.

**How to Navigate**

By means of the "CURSOR-DOWN/UP" knob (or the scroll wheel) on the RC-transmitter, can be navigated through the menus.

**How to Exit CSM**

To exit CSM, use one of the following methods.

- Press the MENU/HOME button on the remote control transmitter.
- Press the POWER button on the remote control transmitter.
- Press the POWER button on the television set.

**5.2.5 Blind SAM Display Option Code Selection**

When after an SSB or display exchange, the display option code is not set properly, it will result in a TV with "no display". Therefore, it is required to set this display option code after such a repair.

To do so, press the following key sequence on a standard RC transmitter: "062598" directly followed by MENU and "xxx", where "xxx" is a 3 digit decimal value of the panel type: see column "Display Code" in [Table 6-2](#). When the value is accepted and stored in NVM, the set will switch to Stand-by, to indicate that the process has been completed.

During this algorithm, the NVM-content must be filtered, because several items in the NVM are TV-related and not SSB related (e.g. Model and Prod. S/N). Therefore, "Model" and "Prod. S/N" data is changed into "See Type Plate". In case a call centre or consumer reads "See Type Plate" in CSM mode, he needs to look to the side/bottom sticker to identify the set, for further actions.



5.3 Stepwise Start-up

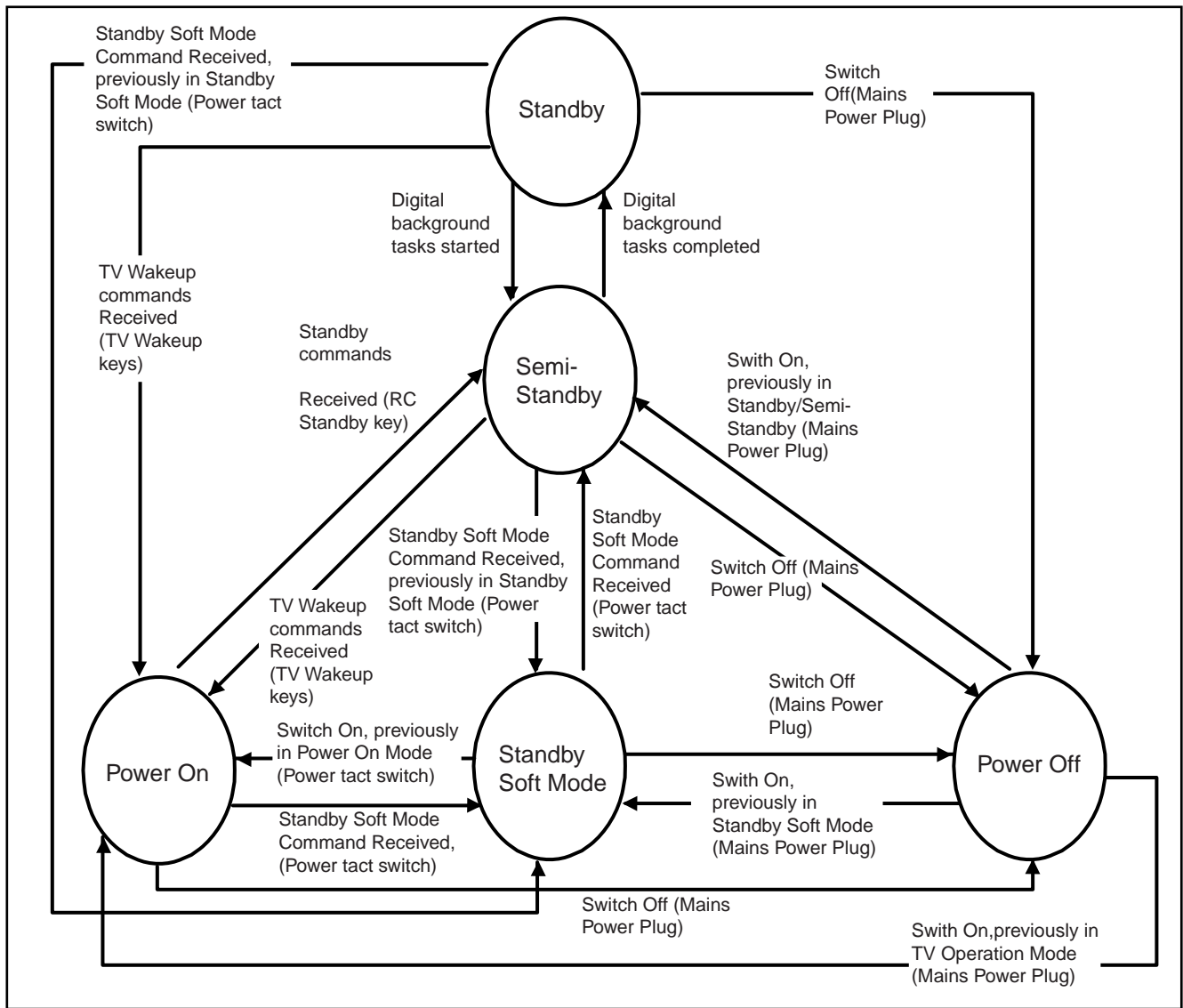

19080\_206\_110323.eps  
110401

Figure 5-6 Stepwise Start-up



## 5.4 Service Tools

### 5.4.1 ComPair

#### Introduction

ComPair (Computer Aided Repair) is a Service tool for Philips Consumer Electronics products, and offers the following:

1. ComPair helps to quickly get an understanding on how to repair the chassis in a short and effective way.
2. ComPair allows very detailed diagnostics and is therefore capable of accurately indicating problem areas. No knowledge on I<sup>2</sup>C or UART commands is necessary, because ComPair takes care of this.
3. ComPair speeds up the repair time since it can automatically communicate with the chassis (when the microprocessor is working) and all repair information is directly available.
4. ComPair features TV software up possibilities.

#### Specifications

ComPair consists of a Windows based fault finding program and an interface box between PC and the (defective) product. The ComPair II interface box is connected to the PC via an USB cable. For the TV chassis, the ComPair interface box and the TV communicate via a bi-directional cable via the service connector(s).

The ComPair fault finding program is able to determine the problem of the defective television, by a combination of automatic diagnostics and an interactive question/answer procedure.

#### How to Connect

This is described in the chassis fault finding database in ComPair.

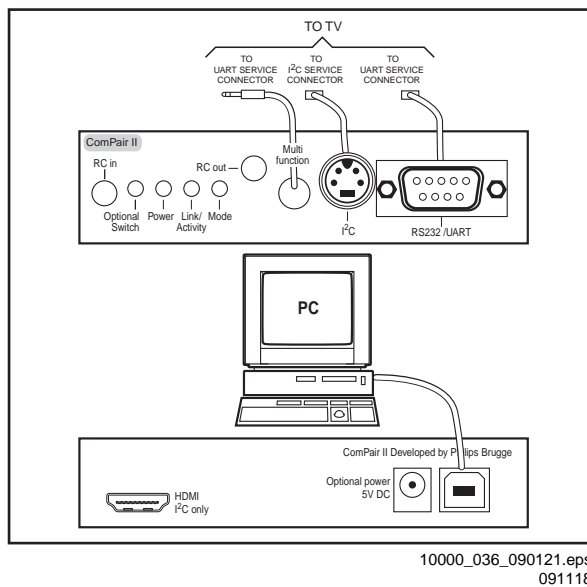

Figure 5-7 ComPair II interface connection

**Caution:** It is compulsory to connect the TV to the PC as shown in the picture above (with the ComPair interface in between), as the ComPair interface acts as a level shifter. If one connects the TV directly to the PC (via UART), ICs can be blown!

#### How to Order

ComPair II order codes:

- ComPair II interface: 3122 785 91020.
- Software is available via the Philips Service web portal.
- ComPair UART interface cable for TPM8.2x xx. (using DB9 to 2mm pitch JST connector): 3122 785 90630.

**Note:** When you encounter problems, contact your local support desk.

#### Additional cables for VCOM Alignment

- ComPair/I2C interface cable: 3122 785 90004.
- ComPair/VGA adapter cable: 9965 100 09269.

**Note:** When you encounter problems, contact your local support desk.

## 5.5 Software Upgrading

### 5.5.1 Description

It is possible for the user to upgrade the main software via the USB port. This allows replacement of a software image in a stand alone set. A description on how to upgrade the main software can be found in the DFU or on the Philips website.

### 5.5.2 Introduction

Philips continuously tries to improve its products, and it's recommend that the TV software is updated when updates are available. Software update files can be obtained from the dealer or can be downloaded from the following websites: <http://www.philips.com/support>

#### Preparing a portable memory for software upgrade

The following requirements have to be met:

1. A personal computer connected to the Internet.
2. An archive utility that supports the ZIP-format (e.g. WinZip for Windows or Stuffit for Mac OS).
3. A USB flash drive (preferably empty).

#### Note:

1. Only FAT/DOS-formatted flash drives are supported.
2. Only use software update files that can be found on the <http://www.philips.com/support> web site.

### 5.5.3 Check the current TV software version

Before starting the software upgrade procedure, it is advised to check that what the current TV software:

1. Press the "123654" button on the remote control to enter the CSM mode.
2. Use the up/down cursor keys to select "Current Main Software".

If the current software version of the TV is the same as the latest update file found on <http://www.philips.com/support>, it is not necessary to update the TV software.

### 5.5.4 Download the latest software

1. Point the web browser to <http://www.philips.com/support>.
2. Find information and software related to the TV.
3. Select the latest software update file and download it to the PC.
4. Insert a USB flash drive into one of the USB ports of the PC.
5. Decompress the downloaded ZIP file and copy the "autorun.upg" to the root directory of the USB flash drive.

### 5.5.5 Update the TV software

1. Insert mains power and wait for system to boot completely.
2. Insert the USB flash drive that contains the software update files.
3. The TV will detect the USB flash drive automatically. Then a window jumps out as [Figure 5-8](#).  
**Note:** If the USB flash drive is not detected after power up, disconnect it and re-insert it.
4. Select [Update] and press OK. See [Figure 5-8](#).

5. To proceed, In next menu select [Start] and press OK to start software updates. See [Figure 5-9](#).
6. Upgrading will now begins and the status of the updating progress will be displayed.
7. When the TV software is updated. Remove your USB flash drive, then select [Restart] and press OK to restart the TV. See [Figure 5-10](#).

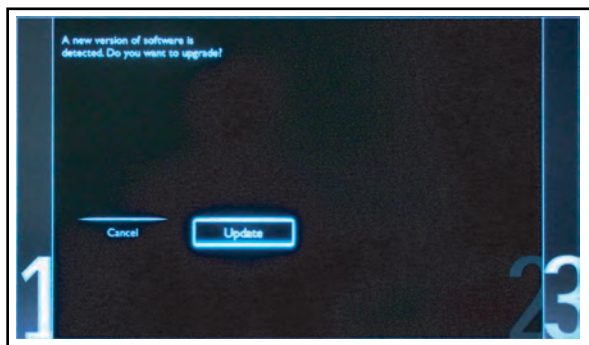

19080\_207\_110324.eps  
110324

Figure 5-8 Update the TV software [1/3]

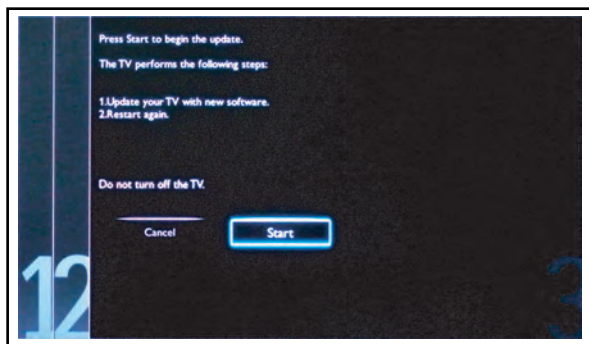

19080\_208\_110324.eps  
110324

Figure 5-9 Update the TV software [2/3]

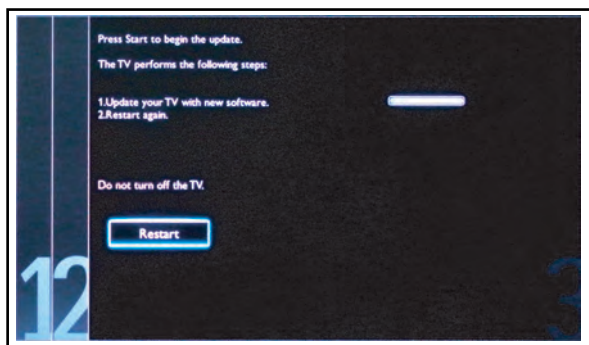

19080\_209\_110324.eps  
110324

Figure 5-10 Update the TV software [3/3]

#### Note:

- Do not remove the USB flash drive during the software update.
- If a power failure occurs during the update, do not remove the USB flash drive from the TV. The TV will continue the software update as soon as the power comes up again.
- If an error occurs during the update retry the procedure or contact the dealer.
- We do not recommend downgrading to an older version.
- Once the upgrade is finished, use the PC to remove the TV software from the USB portable memory.

### 5.5.6 Content and Usage of the One-Zip Software File

Below you find a content explanation of the One-Zip file, and instructions on how and when to use it. Only files that are relevant for Service are mentioned here.

- **EDID\_clustername.zip**: Contains the EDID content of the different EDID NVMs. See ComPair for further instructions.
- **FUS\_clustername\_version.zip**: Contains the "autorun.upg" which is needed to upgrade the TV main software and the software download application.
- **NVM\_clustername\_version.zip**: Default NVM content. Must be programmed via ComPair.

### 5.5.7 How to Copy NVM Data to/from USB

When copying data to and from a USB memory stick, the folder "repair" is used. When inserting an empty USB memory stick, and downloading data to the stick, the TV will create this folder. When sending data from a USB memory stick to a TV, the intended data must be available in the "repair" folder.

Note that when copying EDID data to the TV, all necessary EDID files must be in this folder.

While copying to or from the USB "Repair" Folder to TV, the files need to be named accordingly:

- Channel List: CM\_TPS82E\_LA\_CK.BIN
- EDID 1: HDMI\_1\_EDID\_TPM82E\_LA\_CK.BIN
- EDID 2: HDMI\_2\_EDID\_TPM82E\_LA\_CK.BIN
- VGA\_EDID: VAG\_EDID\_TPM82E\_LA\_CK.BIN
- NVM: NVM\_TPM82E\_LA\_CK.BIN

For copying EDID data to the TV, all 3 EDID files need to be available in repair directory.

## 5.6 Error Codes

### 5.6.1 Introduction

Error codes are required to indicate failures in the TV set. In principle a unique error code is available for every.

- Activated (SW) protection.
- Failing I<sup>2</sup>C device.
- General I<sup>2</sup>C error.

The last five errors, stored in the NVM, are shown in the Service menu's. This is called the error buffer.

The error code buffer contains all errors detected since the last time the buffer was erased. The buffer is written from left to right. When an error occurs that is not yet in the error code buffer, it is displayed at the left side and all other errors shift one position to the right.

An error will be added to the buffer if this error differs from any error in the buffer. The last found error is displayed on the left. An error with a designated error code never leads to a deadlock situation. It must always be diagnosable (e.g. error buffer via OSD or blinking LED or via ComPair). In case a failure identified by an error code automatically results in other error codes (cause and effect), only the error code of the MAIN failure is displayed.

Errors code information:

- **Error 000**: No problem.
- **Error 011**: I<sup>2</sup>C bus error. When this error occurs, the TV will not start up due to the blocked bus.
- **Error 012**: Tuner error. There is no I<sup>2</sup>C communication towards the tuner after start-up.
- **Error 013**: Panel VCC error. This voltage is made in the power supply and results in protection in case of absence.

### 5.6.2 How to Clear the Error Buffer

You can read the error buffer in three ways:

- On screen via the SAM/SDM/CSM (if you have a picture).  
Example:
  - **ERROR: 0 0 0 0 0**: No errors detected.

- **ERROR: 6 0 0 0 0:** Error code 6 is the last and only detected error.
- **ERROR: 9 6 0 0 0:** Error code 6 was detected first and error code 9 is the last detected (newest) error.
- Via the blinking LED procedure (when you have no picture). See paragraph [5.7 The Blinking LED Procedure](#).
- Via ComPair.

### 5.6.3 Error codes

Errors code information:

- **Error 000:** No problem.
- **Error 011:** I<sup>2</sup>C bus error. When this error occurs, the TV will not start up due to the blocked bus.
- **Error 012:** Tuner error. There is no I<sup>2</sup>C communication towards the tuner after start-up.
- **Error 013:** Panel VCC error. This voltage is made in the power supply and results in protection in case of absence.

### 5.6.4 How to Clear the Error Buffer

The error code buffer is cleared in the following cases:

- By using the CLEAR command in the SAM menu.
- By using the following key sequence on the remote control transmitter: "062599" directly followed by the OK button.
- If the contents of the error buffer have not changed for 50 hours, the error buffer resets automatically.

**Note:** If you exit SAM by disconnecting the mains from the television set, the error buffer is not reset.

## 5.7 The Blinking LED Procedure

### 5.7.1 Introduction

The software is capable of identifying different kinds of errors. Because it is possible that more than one error can occur over time, an error buffer is available, which is capable of storing the last five errors that occurred. This is useful if the OSD is not working properly.

Errors can also be displayed by the blinking LED procedure. The method is to repeatedly let the front LED pulse with as many pulses as the error code number, followed by a period of 1.5 seconds in which the LED is "off". Then this sequence is repeated.

**Example (1):** error code 4 will result in four times the sequence LED "on" for 0.25 seconds / LED "off" for 0.25 seconds. After this sequence, the LED will be "off" for 1.5 seconds. Any RC command terminates the sequence. Error code LED blinking is in red colour.

**Example (2):** the content of the error buffer is "12 9 6 0 0" After entering SDM, the following occurs.

- 1 long blink of 5 seconds to start the sequence.
- 12 short blinks followed by a pause of 1.5 seconds.
- 9 short blinks followed by a pause of 1.5 seconds.
- 6 short blinks followed by a pause of 1.5 seconds.
- 1 long blink of 1.5 seconds to finish the sequence.
- The sequence starts again with 12 short blinks.

### 5.7.2 Displaying the Entire Error Buffer

Additionally, the entire error buffer is displayed when Service Mode "SDM" is entered.

## 5.8 Fault Finding and Repair Tips

**Note:**

- It is assumed that the components are mounted correctly with correct values and no bad solder joints.
- Before any fault finding actions, check if the correct options are set.

### 5.8.1 NVM Editor

In some cases, it can be convenient if one directly can change the NVM contents. This can be done with the "NVM Editor" in SAM mode. With this option, single bytes can be changed.

**Caution:**

- Do not change these, without understanding the function of each setting, because incorrect NVM settings may seriously hamper the correct functioning of the TV set!
- Always write down the existing NVM settings, before changing the settings. This will enable you to return to the original settings, if the new settings turn out to be incorrect.

### 5.8.2 Load Default NVM Values

It is possible to upload the default values to the NVM with ComPair in case the SW is changed, the NVM is replaced with a new (empty) one, or when the NVM content is corrupted. After replacing an EEPROM (or with a defective/no EEPROM), default settings should be used to enable the set to start-up and allow the Service Default Mode and Service Alignment Mode to be accessed.

### 5.8.3 No Picture

When you have no picture, first make sure you have entered the correct display code. See paragraph [6.4 Option Settings](#) for the instructions. See also [Table 6-2](#).

### 5.8.4 Unstable Picture via HDMI input

Check (via ComPair) if HDMI EDID data is properly programmed.

### 5.8.5 No Picture via HDMI input

Check whether the HDCP key is valid. This can be done in CSM.

### 5.8.6 TV Will Not Start-up from Stand-by

Possible Stand-by Controller failure. Reflash the software.

### 5.8.7 CSM

When CSM is activated and there is a USB memory stick connected to the TV, the software will dump the complete CSM content to the USB memory stick. The file (CSM\_CTN name\_serial no.txt) will be saved in the root of the USB memory stick.

### 5.8.8 Loudspeakers

Make sure that the volume is set to minimum during disconnecting the speakers in the ON-state of the TV. The audio amplifier can be damaged by disconnecting the speakers during ON-state of the set!

### 5.8.9 Display option code

Attention: In case the SSB is replaced, always check the Display Code in CSM, even when picture is available. Performance with the incorrect display option code can lead to unwanted side-effects for certain conditions.

## 6. Alignments

Index of this chapter:

[6.1 General Alignment Conditions](#)

[6.2 Hardware Alignments](#)

[6.3 Software Alignments](#)

[6.4 Option Settings](#)

[6.5 Reset of Repaired SSB](#)

### 6.1 General Alignment Conditions

Perform all electrical adjustments under the following conditions:

- Power supply voltage: 195 - 264 V<sub>AC</sub>, 50/ 60 ± 3 Hz.
  - Connect the set to the mains via an isolation transformer with low internal resistance.
  - Allow the set to warm up for approximately 15 minutes.
  - Measure voltages and waveforms in relation to correct ground (e.g. measure audio signals in relation to AUDIO\_GND).
- Caution:** It is not allowed to use heat sinks as ground.
- Test probe: R<sub>i</sub> > 10 MΩ, C<sub>i</sub> < 20 pF.
  - Use an isolated trimmer/screwdriver to perform alignments.

### 6.2 Hardware Alignments

Not applicable.

### 6.3 Software Alignments

Put the set in SAM mode (see Chapter [5. Service Modes, Error Codes, and Fault Finding](#)). The SAM menu will now appear on the screen. Select RGB Align and go to one of the sub menus. The alignments are explained below.

The following items can be aligned:

- White point

To store the data:

- Press OK on the RC **before the cursor is moved to the left**
- Select "Store" and press OK on the RC
- Switch the set to stand-by mode.

For the next alignments, supply the following test signals via a video generator to the RF input:

- **EU/AP-PAL models:** a PAL B/G TV-signal with a signal strength of at least 1 mV and a frequency of 475.25 MHz
- **US/AP-NTSC models:** an NTSC M/N TV-signal with a signal strength of at least 1 mV and a frequency of 61.25 MHz (channel 3).
- **LATAM models:** an NTSC M TV-signal with a signal strength of at least 1 mV and a frequency of 61.25 MHz (channel 3).

#### 6.3.1 Display adjustment

You can use the default values. The default values are average values coming from production.

- Enter SAM mode.
- Select a colour temperature (e.g. COOL, NORMAL, or WARM).
- Set the RED, GREEN and BLUE default values according to the values in [Table 6-1](#).
- When finished press OK on the RC, then press STORE to store the aligned values to the NVM.
- Restore the initial picture settings after the alignments.

Table 6-1 White tone default settings

Picture mode	Screen size	Colour temperature		
		Red	Green	Blue
Normal (9000K)	19" (Golden horse)	128	118	100
	22" (Golden horse)	128	105	97
	22" (Spot Deal)	78	99	128
	26" (Golden horse)	128	115	109
	32" (Spot Deal)	128	112	107
Cool (11000K)	19" (Golden horse)	128	122	118
	22" (Golden horse)	128	106	114
	22" (Spot Deal)	63	85	128
	26" (Golden horse)	128	114	124
	32" (Spot Deal)	62	86	127
Warm (6500K)	19" (Golden horse)	128	108	61
	22" (Golden horse)	128	95	59
	22" (Spot Deal)	118	128	122
	26" (Golden horse)	128	106	67
	32" (Spot Deal)	116	93	56

This group setting of colour temperature will be applied automatically to the TV / VGA / HDMI / AV sources.

### 6.4 Option Settings

#### 6.4.1 Introduction

The microprocessor communicates with a large number of I<sup>2</sup>C ICs in the set. To ensure good communication and to make digital diagnosis possible, the microprocessor has to know which ICs to address. The presence / absence of these MT5366 ICs (back-end advanced video picture improvement IC which offers motion estimation and compensation features (commercially called HDNM) is made known by the option codes.

#### 6.4.2 Option Code Overview

Enter SAM mode to check the option codes. They can not be edited in the NVM.

### 6.4.3 Display Code Overview

Press the following key sequence on a standard RC transmitter: "062598" directly followed by MENU and "xxx", where "xxx" is a 3 digit decimal value of the panel type: see column "Display Code" in [Table 6-2](#). When the value is accepted and stored in NVM, the set will switch to Stand-by, to indicate that the process has been completed.

**Table 6-2 Display code overview**

CTN_ALT BOM#	Panel Type	Display Code
19HFL3233D/10	LGD LC185WH1-TLG1	131
19PFL3606H/12	LGD LC185WH1-TLG1	131
19PFL3606H/58	LGD LC185WH1-TLG1	131
19PFL3606H/60	LGD LC185WH1-TLG1	131
22PFL3206H/12	TPV TPM215HW01-HGEL01 C2A FQ	138
22PFL3206H/58	TPV TPM215HW01-HGEL01 C2A FQ	138
22PFL3606H/12	LGD LC215WUE-TCA1	132
22PFL3606H/58	LGD LC215WUE-TCA1	132
22PFL3606H/60	LGD LC215WUE-TCA1	132
26PFL3606H/12	LGD LC260WXE-SBB1	133
26PFL3606H/58	LGD LC260WXE-SBB1	133
26PFL3606H/60	LGD LC260WXE-SBB1	133
32PFL5206H/12	AUO T315XW06 V301 SZ	139
32PFL5206H/58	AUO T315XW06 V301 SZ	139
32PFL5206H/60	AUO T315XW06 V301 SZ	139

## 6.5 Reset of Repaired SSB

A very important issue towards a repaired SSB from a Service repair shop (SSB repair on component level) implies the reset of the NVM on the SSB.

A repaired SSB in Service should get the service Set type "00PF0000000000" and Production code "00000000000000". Also the virgin bit (MENU > Setup > TV settings > Reinstall TV > Start now) is to be set. To set all this, you can use the ComPair tool or use the "NVM editor" and "Service Data" items in SAM (do not forget to "store").

After a repaired SSB has been mounted in the set (set repair on board level), the type number (CTN) and production code of the TV has to be set according to the type plate of the set. For this, you can use the NVM editor in SAM. The loading of the CTN and production code can also be done via ComPair (Model number programming).

In case of a display replacement, reset the "Operation hours display" to "0", or to the operation hours of the replacement display.



# 7. Circuit Descriptions

**Index of this chapter:**

- [7.1 Introduction](#)
- [7.2 Power Supply](#)
- [7.3 Power Management](#)
- [7.4 Circuit Description](#)

**Notes:**

- Only **new** circuits (circuits that are not published recently) are described.
- Figures can deviate slightly from the actual situation, due to different set executions.
- For a good understanding of the following circuit descriptions, please use the wiring, block (see chapter 9. [Block Diagrams](#)) and circuit diagrams (see chapter 10. [Circuit Diagrams and PWB Layouts](#)). Where necessary, you will find a separate drawing for clarification.

## 7.1 Introduction

The TPM8.2E LA platform uses MT5366/MT5135. It supports decoder and a TV controller offers high integration for advanced applications. It combines a transport de-multiplexer, a high definition video decode, an AC3 decode, a dual-link LVDS/mini-LVDS transmitter, and an NTSC/PAL/SECAM TV decoder with a 3D comb filter (NTSC/PAL).

- MT5366CVOU System-On-Chip (SOC) TV Processor
- TDTK-G731D Tuner (DVB T/C, analogue)
- MT5135AE DVB T/C demodulator
- TAS5717 Audio amplifier

### 7.1.2 TPM8.2E Architecture Overview

#### 7.1.1 Implementation

Key components of this chassis are:

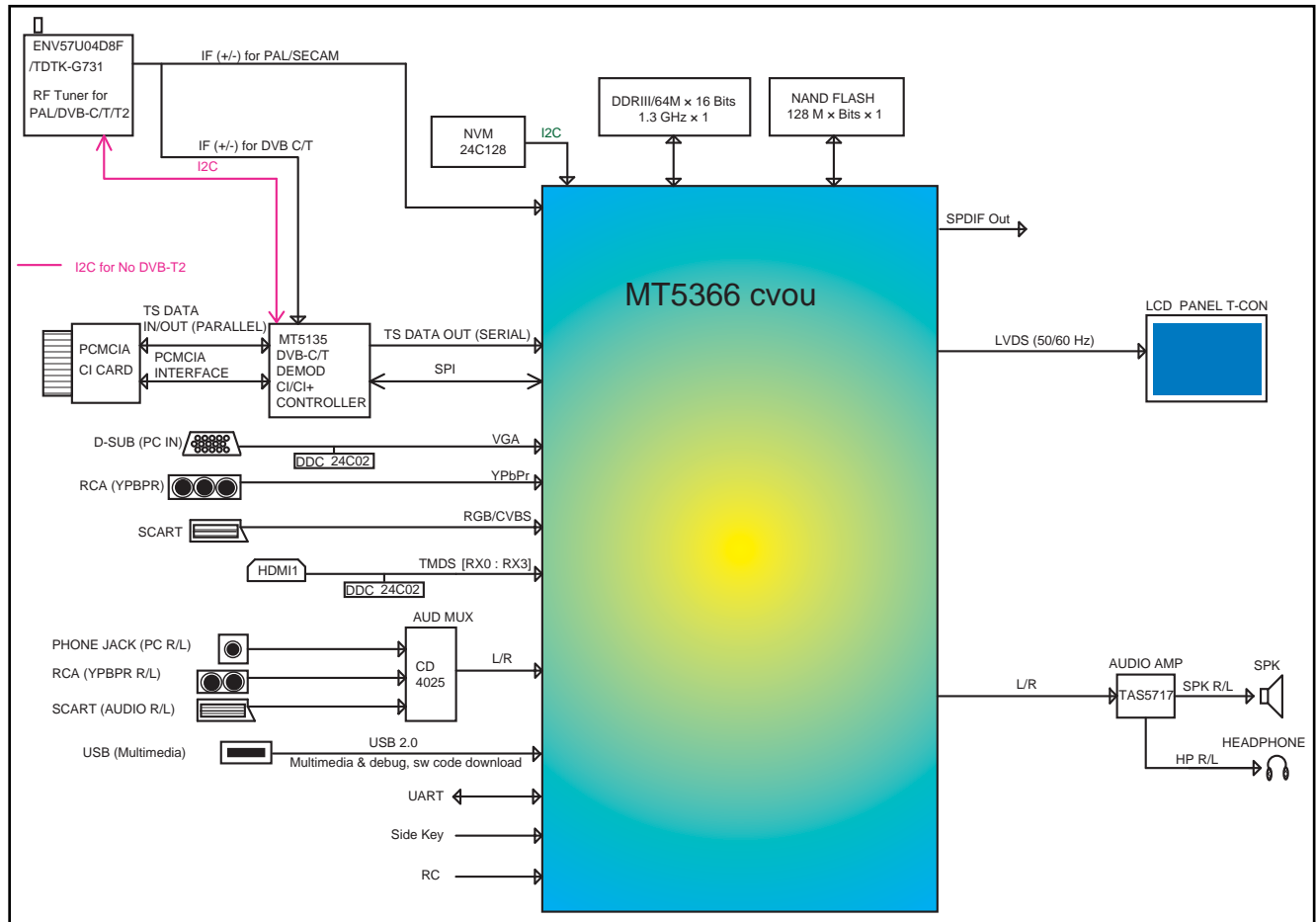

19120\_205\_110512.eps  
110526

Figure 7-1 Architecture of TPM8.2E LA

7.1.3 SSB Cell Layout

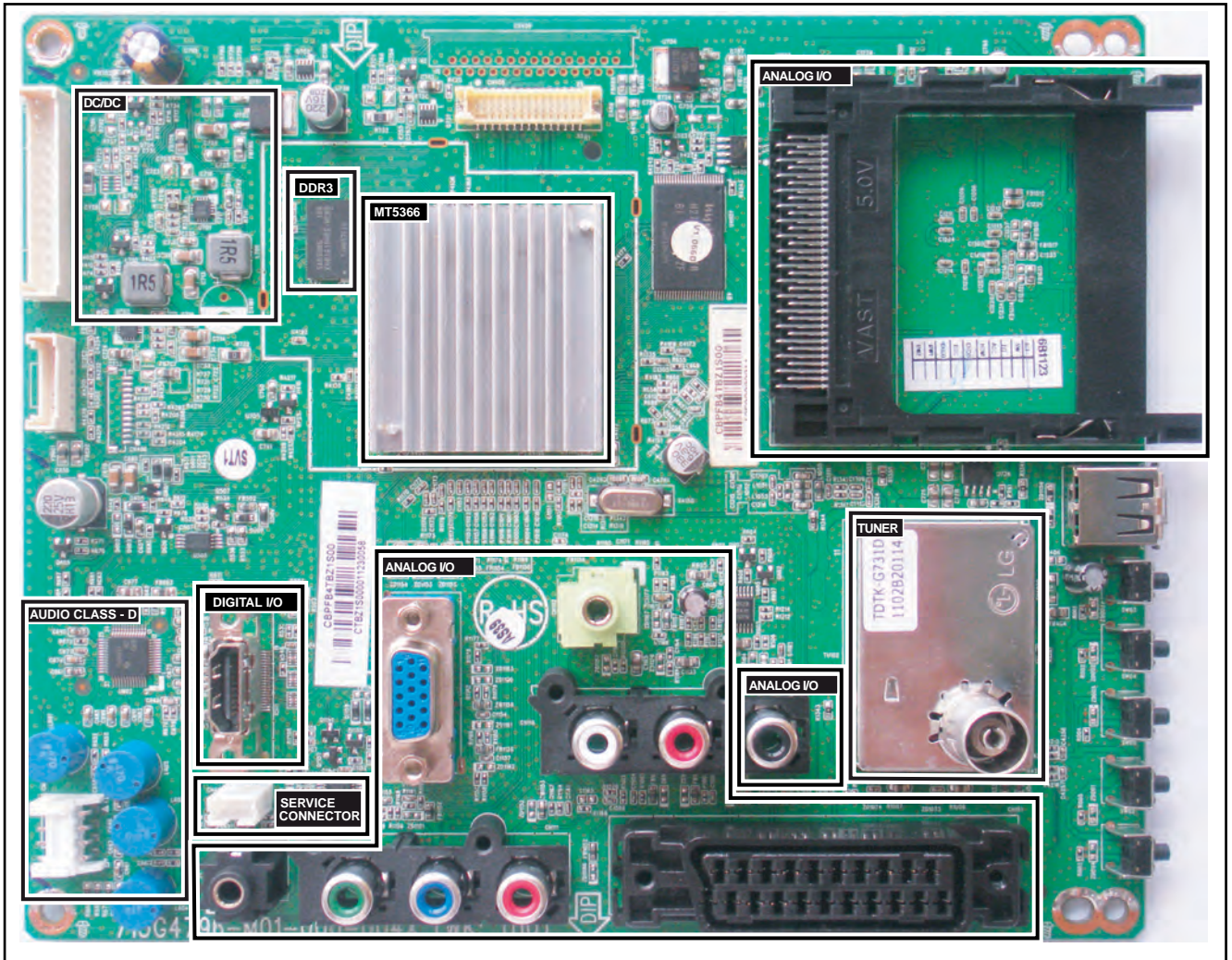

19120\_206\_110516.eps  
110525

Figure 7-2 SSB layout cells (top view)

## 7.2 Power Supply

### 7.2.1 Power Supply Unit

Before checking other parts first check whether fuse on the PSU is not broken. Always replace a defective fuse with one with the correct specifications! This part is available in the regular market.

Consult the Philips Service web portal for the order codes of the boards.

### 7.3 Power Management

The output voltages to the chassis are:

- +5V-STANDBY (Stand-by mode only)
- +12V (on-mode)
- +18V for audio circuit

#### 7.2.2 Diversity

The diversity in power supply units is mainly determined by the diversity in screen sizes, but please note to always order the correct replacement.

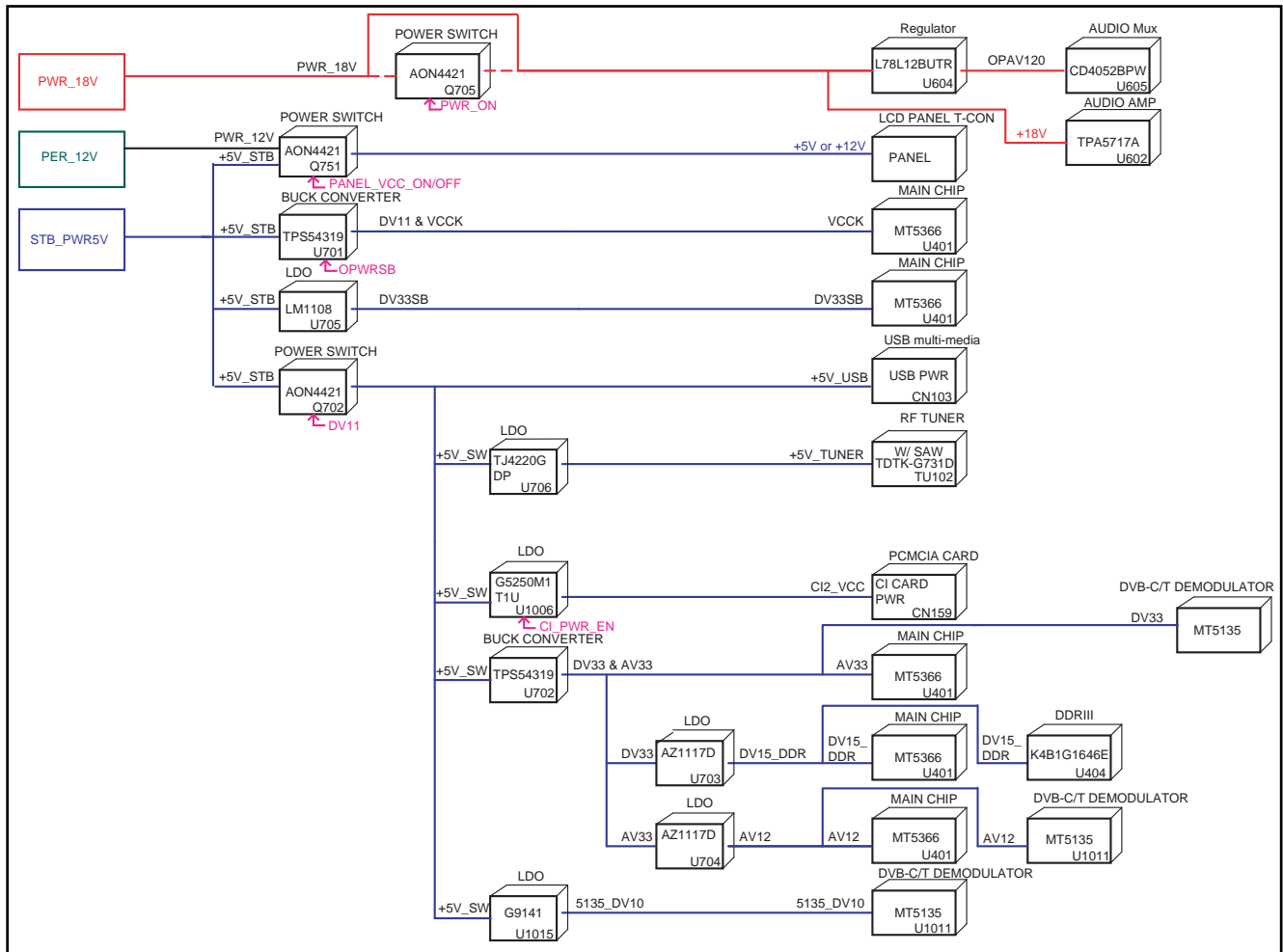

19120\_207\_110516.eps  
110526

Figure 7-3 Power Architecture

The on-board DC/DC converters deliver the following voltages (depending on set execution):

- +5V-STANDBY, permanent voltage for the Stand-by controller, LED/IR receiver and controls; connector CN701 pin 11 and 12.
- +12V, input from the power supply for T-con, audio amp in SCART out; connector CN701 pins 3 and 4.
- +18V, input from the power supply for audio (in active mode); connector CN701 pins 8 and 9.



## 7.4 Circuit Description

### 7.4.1 System power

The main board power is received at connector CN701 from power board, to receive the power and signals from the PSU. See [Table 7-1](#) for the correct pinning, The shown test points in [Figure 7-4](#).

Table 7-1 Connector CN701 overview

Item	Pin	Description
1	1	INVERTER_ON_OFF, Inverter board control (Low: OFF, High: ON)
2	2	BRIGHT_ADJ, Inverter bright PWM control (Max.: 0 V, Min.: 3.3 V)
3	3, 4	+12 V Supply
4	5, 6, 7	Ground
5	8, 9	+18 V Supply
6	10	STANDBY, Standby control (High: Normal, Low: Stand by)
7	11, 12	STB_PWR5V, +5VSB Supply

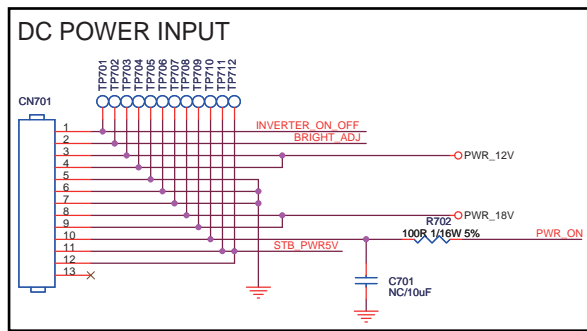

19120\_208\_110518.eps  
110524

Figure 7-4 System power

### 7.4.2 Tuner power

TJ4220GDP provides the tuner power of approximately 5 V.

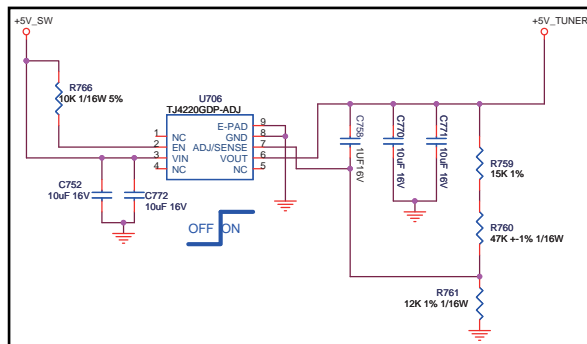

19120\_210\_110518.eps  
110518

Figure 7-5 Tuner power

### 7.4.3 DDR3 1.5V

This AZ117D provides the 1.5 V power supply for the DDR memory (U404).

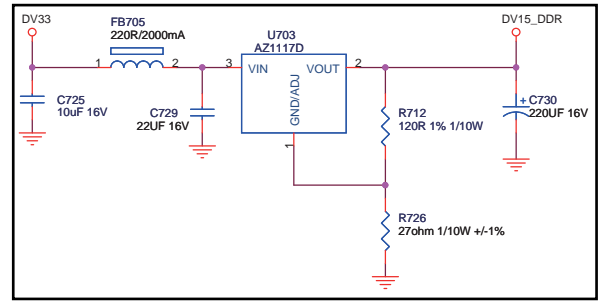

19120\_212\_110518.eps  
110518

Figure 7-6 DDR3 1.5V

### 7.4.4 AV12 (U704)

This AZ117D provides the 1.2 V power supply for the DVBT/C demodulator (U1011)

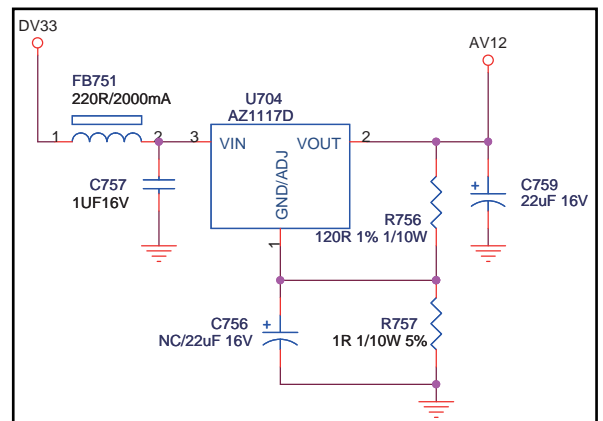

19120\_213\_110518.eps  
110518

Figure 7-7 AV12 (U704)

### 7.4.5 Nand flash Memory (U4051)

The set uses a 128 MB NAND flash for software code

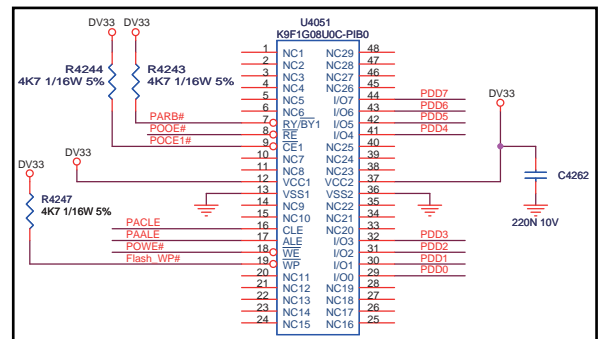

19120\_214\_110519.eps  
110519

Figure 7-8 Nand flash Memory (U4051)

7.4.6 NVM (U409)

The system EEPROM is a 128 kB IC. It contains all system settings.

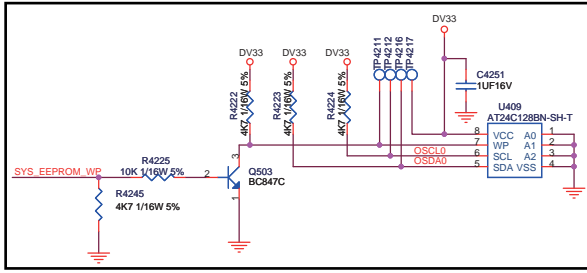

19120\_215\_110519.eps  
110519

Figure 7-9 NVM (U409)

7.4.7 Reset (U410)

When the input voltage for the MT5366 main processor drops below 2.9 V, a system reset will be enforced by U410.

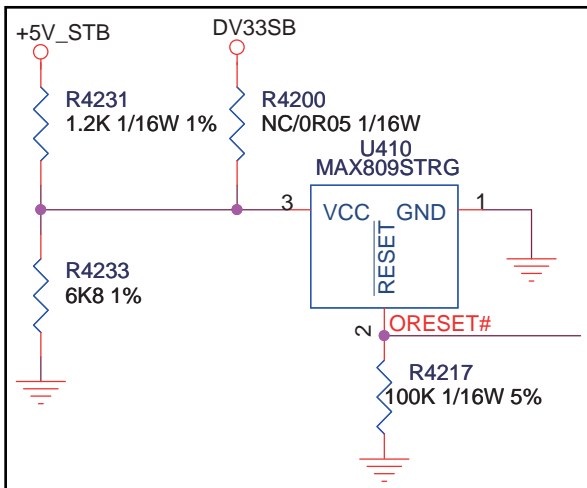

19120\_216\_110519.eps  
110526

Figure 7-10 Reset (U410)

7.4.9 AV33 and DV33 (U702)

The circuit around U702 will provide the main 3.3 V power supply to the SSB.

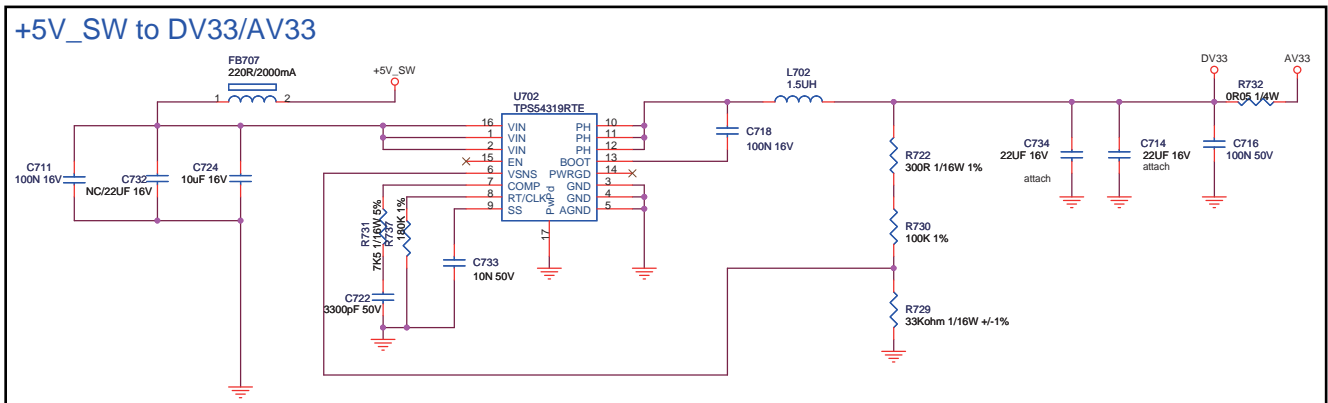

19120\_209\_110518.eps  
110518

Figure 7-12 AV33 and DV33 (U702)

7.4.8 Audio Mute circuit

This circuit will provide a “high-to-low” pulse when the +5 V SSB power line goes low. This will trigger the related audio mute circuit, preventing the audio circuit making uncontrolled sounds.

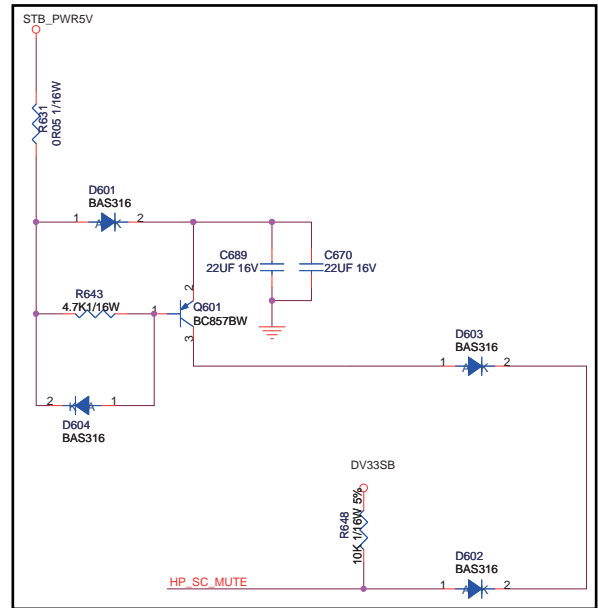

19120\_217\_110519.eps  
110519

Figure 7-11 Audio Mute circuit

7.4.10 Core Power

The circuit around U701 will provide the main 1.1 V power supply to the MT5366 micro processor.

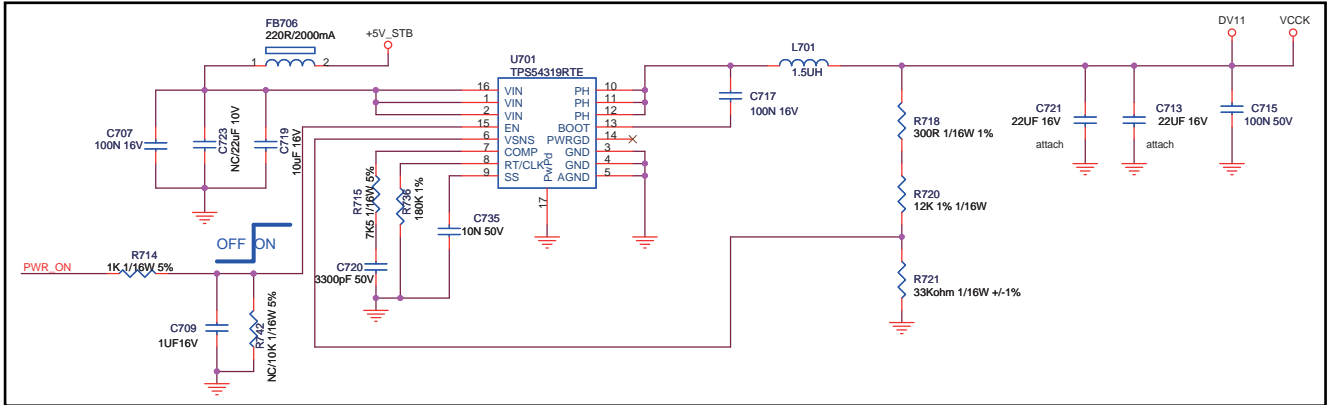

19120\_211\_110518.eps  
110518

Figure 7-13 Core Power

7.4.11 Audio Amplifier (U602)

The TAS5717 is providing the audio amplification to the speakers and headphone from digital input signals. It's I<sup>2</sup>S signals enter the IC via pins 20 to 24. The IC contains two

separate stereo Class-D amplifiers for the normal speakers as well as for the headphone. In the headphone plug a signalling switch is coupled to the main processor which then via I<sup>2</sup>S controls the amplifier.

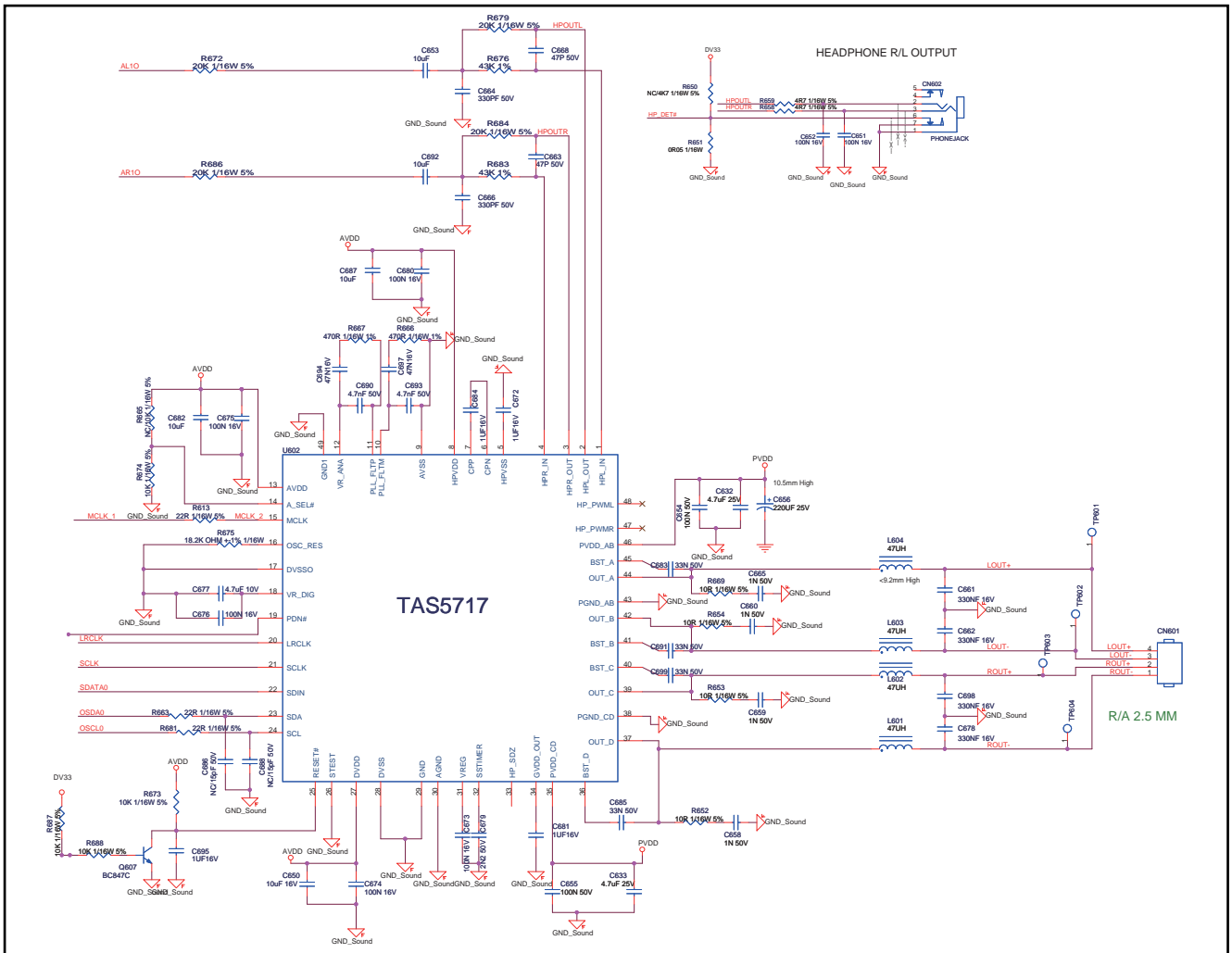

19120\_218\_110519.eps  
110531

Figure 7-14 Audio Amplifier (U602)

7.4.12 Demodulator

The MT5135AE provides a high performance DVB-T and DVB-C demodulation function, the integrated CI+ controller and interface also reduces the complexity of TS routing. Overall Features:

- Integrated DVB-T and DVB-C demodulators.
- Integrated CI/CI+ controller and interface.

- On-chip integrated SAW filter function.
- 10-Bit ADC accepting IF or low-IF inputs.
- RSSI measurement.
- Independent RF and IF AGC controls.
- One parallel or serial TS interface accepting output.

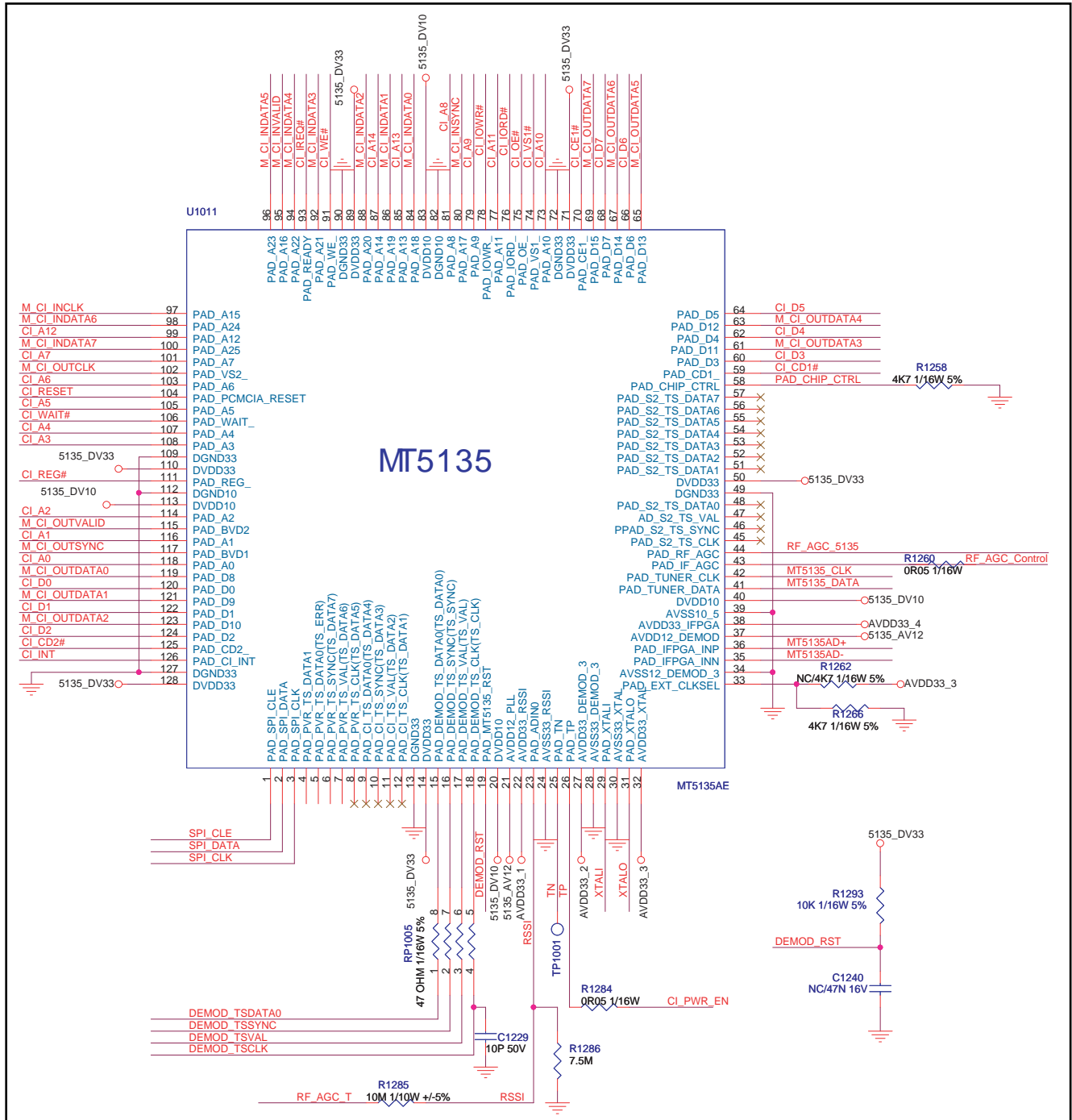

19120\_219\_110519.eps  
110519

Figure 7-15 Demodulator

7.4.13 Tuner

The tuner covers all bands in VHF and UHF. It includes digital terrestrial (DVB-T), -cable (DVB-C), and analogue (PAL, Secam). The tuner is fully controlled via the I<sup>2</sup>C bus for address selection, as well as broadcast system selection.

# 8. IC Data Sheets

This chapter shows the internal block diagrams and pin configurations of ICs that are drawn as “black boxes” in the

electrical diagrams (with the exception of “memory” and “logic” ICs).

## 8.1 Diagram MT5366 cvou B03, MT5366CVOU LQFP-256 (IC U401)

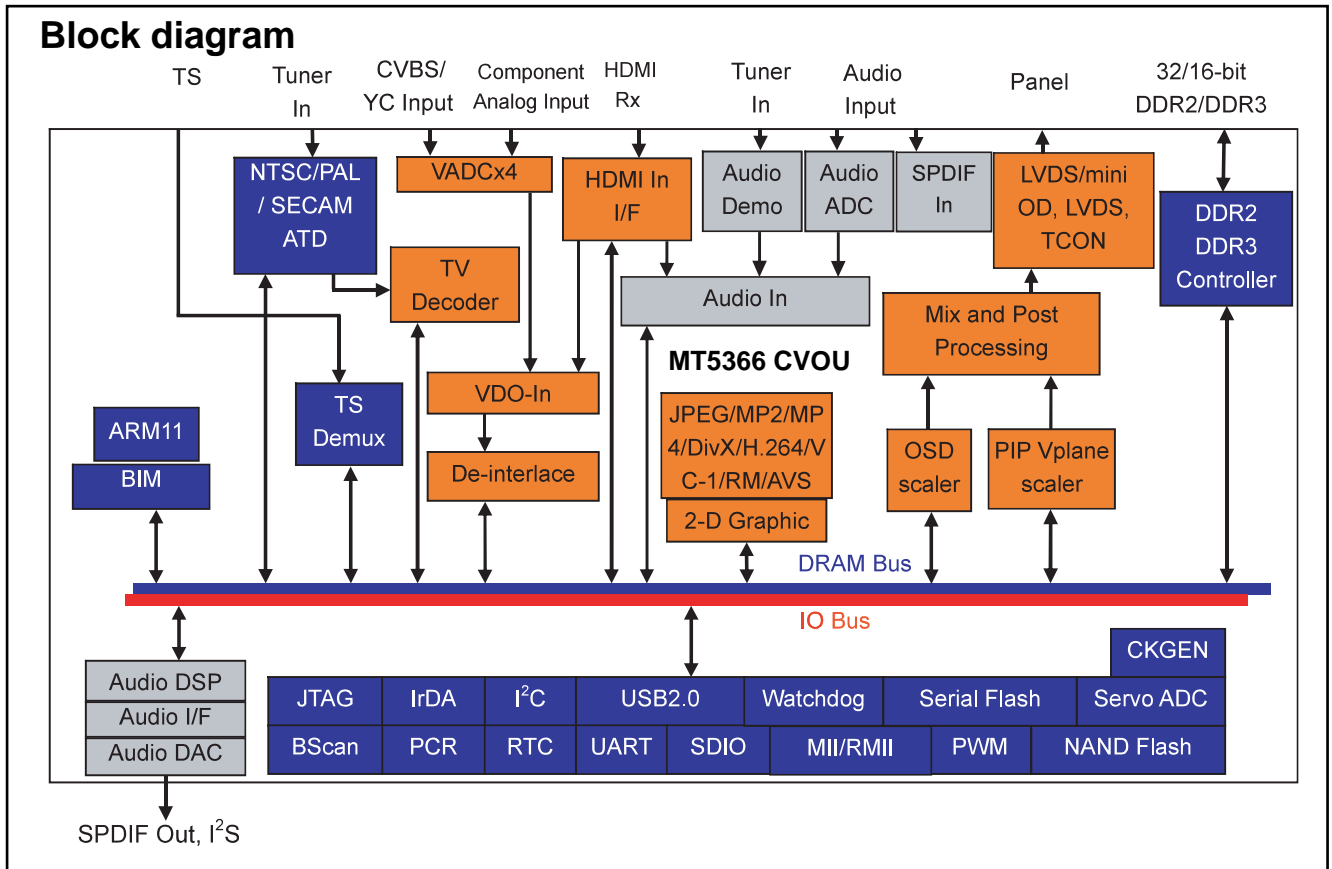

19120\_300\_110516.eps  
110526

Figure 8-1 Internal block diagram

# Pinning information

GPIO4	258	189	AVDD33_XTAL_STB
FSRC_WR	1	191	XTALI
GPIO14	2	190	XTALO
VCC3IO	3	188	AVDD33_DEMOD
AVDD12_VPLL	4	188	AVSS33_DEMOD
AE5P	5	187	AVSS12_DEMOD
AE5N	6	188	AVDD33_IFPGA
AE4P	7	188	ADCINN_DEMOD
AE4N	8	184	ADCINP_DEMOD
AE3P	9	188	AVDD12_DEMOD
AE3N	10	188	AVDD33_CVBS
AECKP	11	181	CVBS0P
AECKN	12	180	CVBS_COM
AE2P	13	178	CVBS1P
AE2N	14	178	SY0
AE1P	15	177	SCO
AE1N	16	178	SY1
AE0P	17	178	SC1
AE0N	18	174	AVDD12_PLL
AVDD33_LVDSA	19	178	VCCX
AVDD33_LVDSA	20	178	FS_VDAC
A05P	21	171	AVDD33_VDAC
A05N	22	171	VDAC_OUT1
A04P	23	168	VDAC_OUT2
A04N	24	168	AVSS12_RGB
A03P	25	167	AVDD12_RGB
A03N	26	168	PR0P
A0CKP	27	168	PR0P
A0CKN	28	164	COM0
A02P	29	163	Y0P
A02N	30	162	SOY0
A01P	31	161	PR1P
A01N	32	160	PB1P
A00P	33	158	COM1
A00N	34	158	Y1P
VCCX	35	157	SOY1
VCCX	36	158	RP
VCCX	37	158	COM
AVDD12_MEMPLL	38	154	GP
AVSS12_MEMPLL	39	153	SOG
RODT/RCKE	40	152	BP
RA8/RA10	41	151	HSYNC
RA13/RBA1	42	150	VSYNC
RA11/RA4	43	148	AVDD33_VGA_STB
RA4/RA1	44	148	AVDD10_LDO
RA6/RA6	45	147	ADIN4_SRV
RA0/RA8	46	148	ADIN3_SRV
RA2/RA11	47	148	ADIN2_SRV
RCA5_/RA12	48	144	ADIN1_SRV
RCS_/RRAS	49	143	ADIN0_SRV
RRAS_/RCA5_	50	142	VCCX
RA9/RWE	51	141	VGA_SCL
VCC2IO	52	140	VGA_SDA
RA12/RA0	53	138	OPWRSB
RA7/RA13	54	138	OPCTRL1
RA5/RA9	55	137	OPCTRL0
NC/RRRESET_	56	138	QIRI
RA3/RA7	57	138	U0TX
RA1/RA2	58	138	U0RX
RA10/RA5	59	138	AVDD33_PDM_STB
RBA1/RA3	60	137	OPCTRL2
RBA0/RBA2	61	137	OPCTRL4
RBA2/RBA0	62	137	OPCTRL3
RWE_/RCS	63	130	OPCTRL5
RCKE/RODT	64	128	OPCTRL5
128	128	128	OPCTRL5
127	127	127	OPWRSB
126	126	126	HDMI_HPD
125	125	125	HDMI_SCL
124	124	124	HDMI_SDA
123	123	123	HDMI_CEC
122	122	122	AVDD12_HDMI
121	121	121	RX_2
120	120	120	RX_2B
119	119	119	RX_1
118	118	118	RX_1B
117	117	117	RX_0
116	116	116	RX_0B
115	115	115	RX_CB
114	114	114	RX_CB
113	113	113	AVDD33_HDMI
112	112	112	USB_2P_VRT
111	111	111	AVDD33_USB_2P
110	110	110	USB_2P_DP0
109	109	109	USB_2P_DM0
108	108	108	USB_2P_DP1
107	107	107	USB_2P_DM1
106	106	106	VCCX
105	105	105	VCC2IO
104	104	104	OPWMD
103	103	103	JTRST
102	102	102	JTDI
101	101	101	JTMS
100	100	100	JTCK
99	99	99	JTCK
98	98	98	JTRST
97	97	97	RCLK0_JRCLK0
96	96	96	RCLK0_JRCLK0
95	95	95	VCC2IO
94	94	94	R0G5/R0G5
93	93	93	R0G7/R0G7
92	92	92	VCC2IO
91	91	91	R0G0/R0G3
90	90	90	R0G7/R0G1
89	89	89	R0G13/R0G8
88	88	88	R0G10/R0G10
87	87	87	VCC2IO
86	86	86	R0G8/R0G14
85	85	85	R0G15/R0G12
84	84	84	R0G11/R0G11
83	83	83	VCC2IO
82	82	82	R0G9/R0G5
81	81	81	R0G10/R0G10
80	80	80	R0G50_JR0G50
79	79	79	R0G50_JR0G50
78	78	78	VCCX
77	77	77	R0G11/R0G11
76	76	76	R0G11/R0G15
75	75	75	R0G14/R0G13
74	74	74	VCC2IO
73	73	73	R0G9/R0G9
72	72	72	R0G12/R0G11
71	71	71	R0G8/R0G0
70	70	70	R0G11/R0G2
69	69	69	VCC2IO
68	68	68	R0G3/R0G6
67	67	67	R0G4/R0G4
66	66	66	R0G4/R0G4
65	65	65	R0G4/R0G4

# MT5366

Figure 8-2 Pin configuration

8.2 Diagram [DVB-T+C DEMOD MT5135 / CI B10, MT5135AE/A LQFP-128 \(IC U1011\)](#)

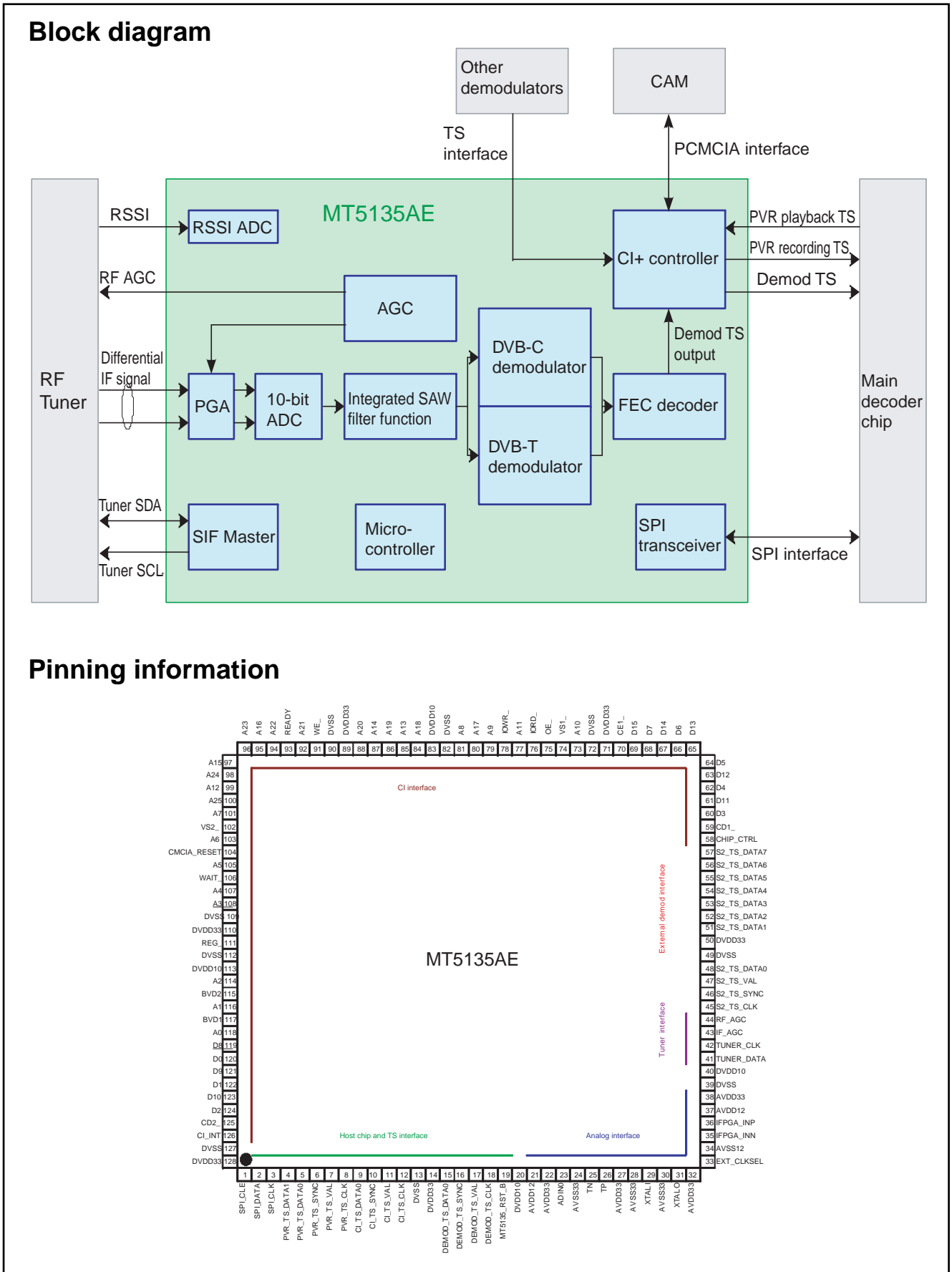

19080\_303\_110317.eps  
110330

Figure 8-3 Internal block diagram and pin configuration

8.3 Diagram **SPK AMP / HP AMP / AUD MUX** B05, TAS5717 HTQFP-48 10W (IC U602)

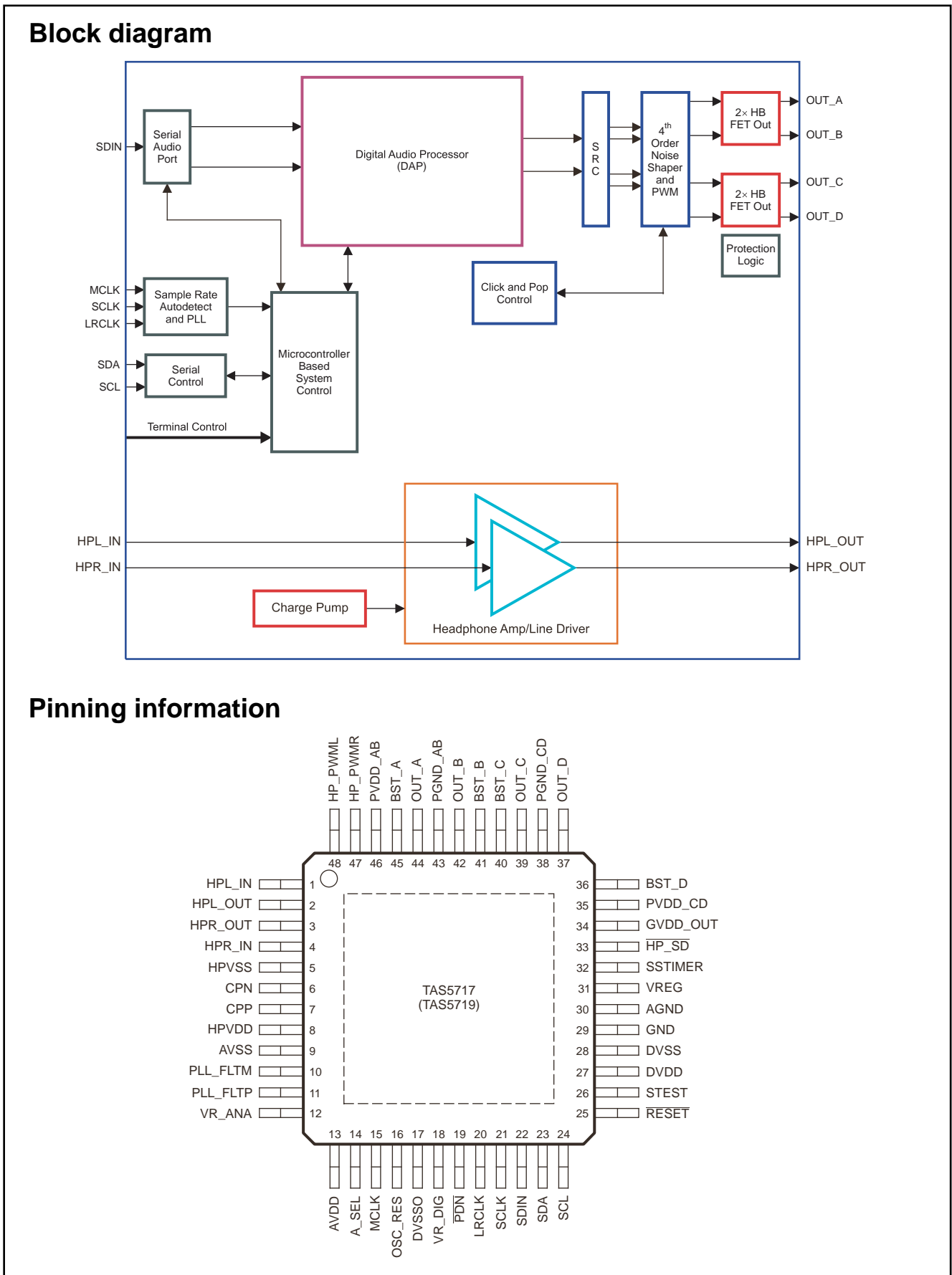

19120\_302\_110516.eps  
110516

Figure 8-4 Internal block diagram and pin configuration



8.4 Diagram [Power-1 B01](#), G5173R41D (IC U701)

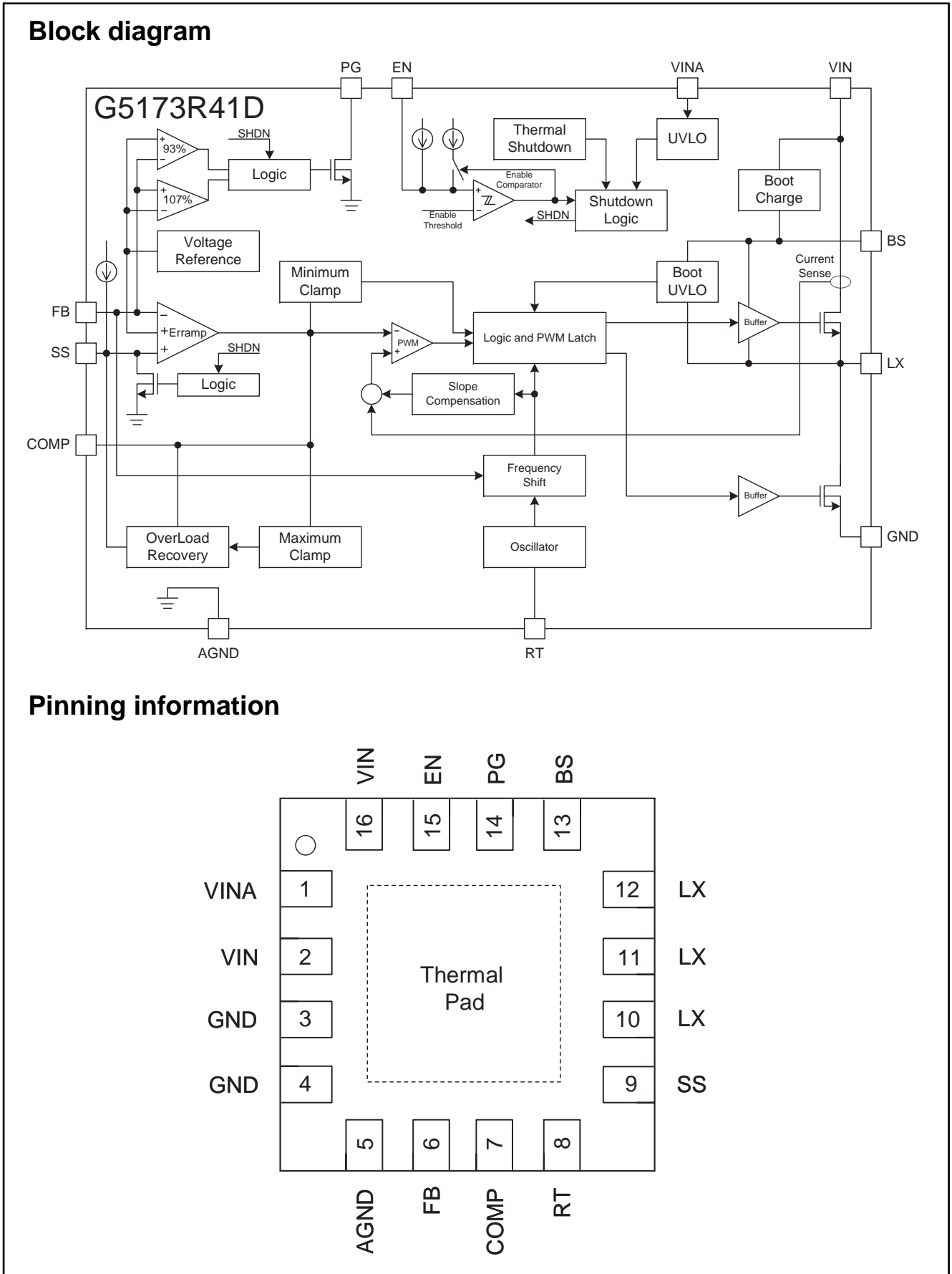

19120\_303\_110517.eps  
110524

Figure 8-5 Internal block diagram and pin configuration



# 9. Block Diagrams

## 9-1 Wiring diagram 19" Golden horse

WIRING DIAGRAM 19" (Golden horse)

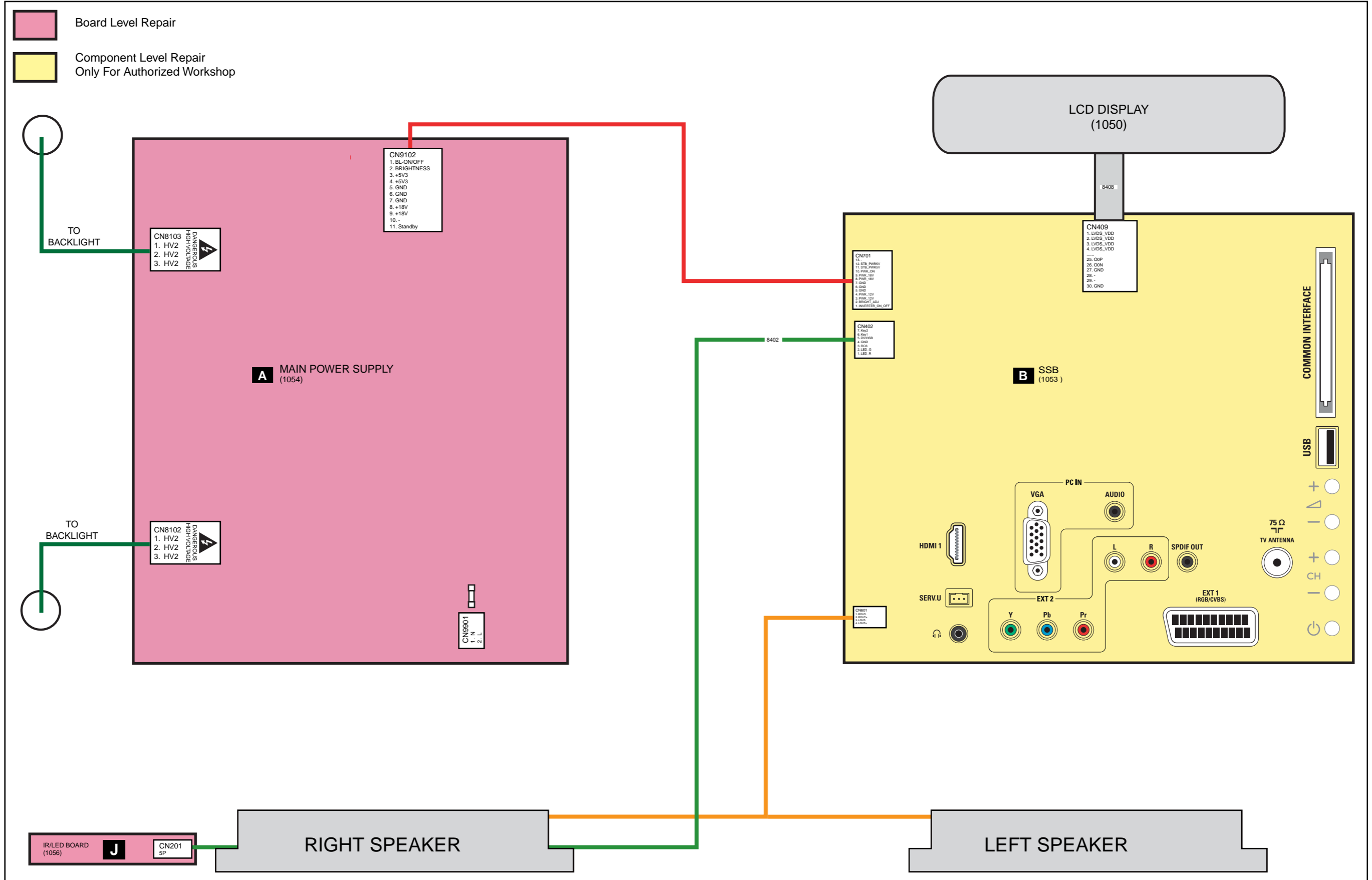

**9-2 Wiring diagram 22" Golden horse**

WIRING DIAGRAM 22" (Golden horse)

- Board Level Repair
- Component Level Repair  
Only For Authorized Workshop

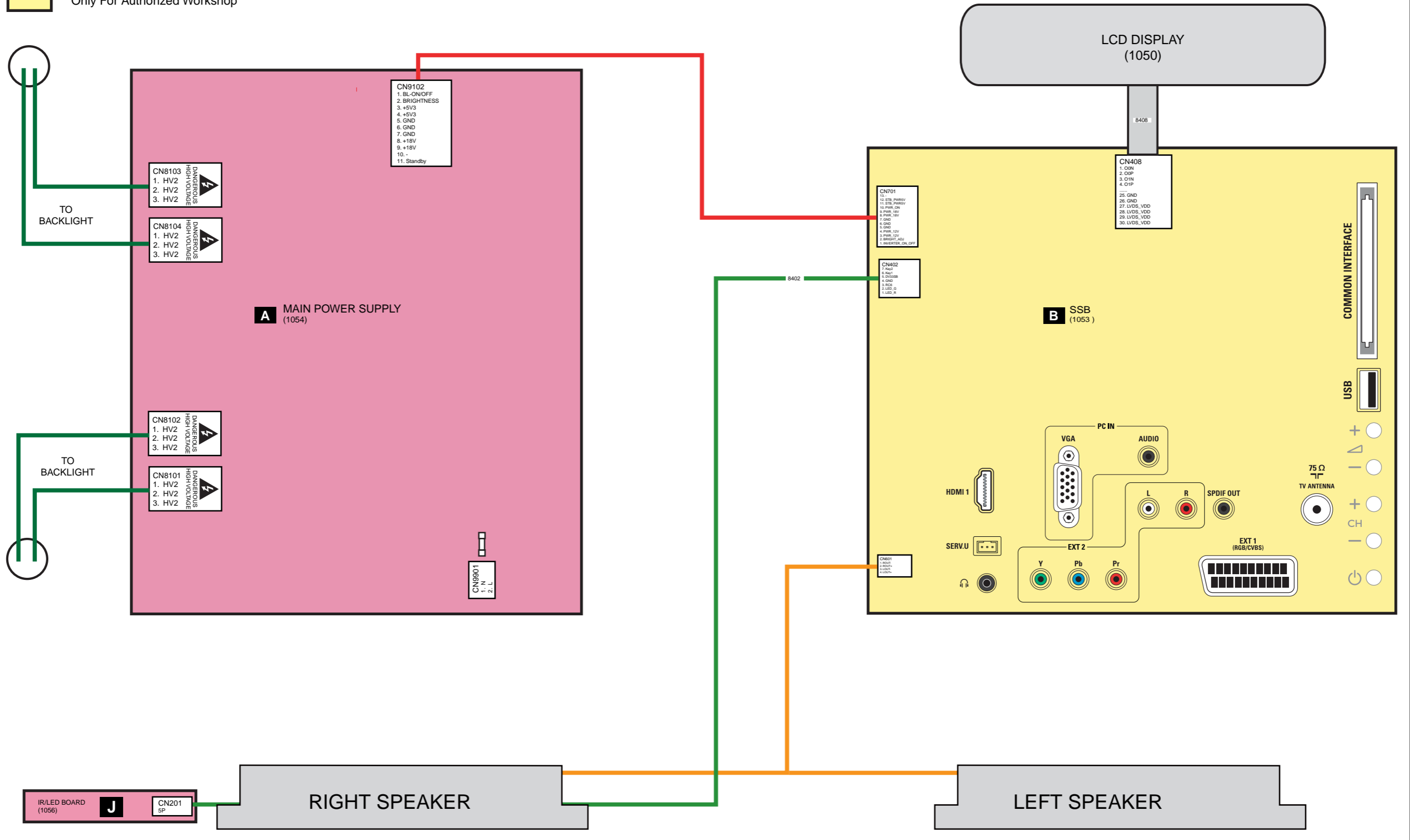

19120\_401\_110519.eps  
110526

### 9-3 Wiring diagram 22" Spot Deal

WIRING DIAGRAM 22" (Spot Deal)

- Board Level Repair
- Component Level Repair  
Only For Authorized Workshop

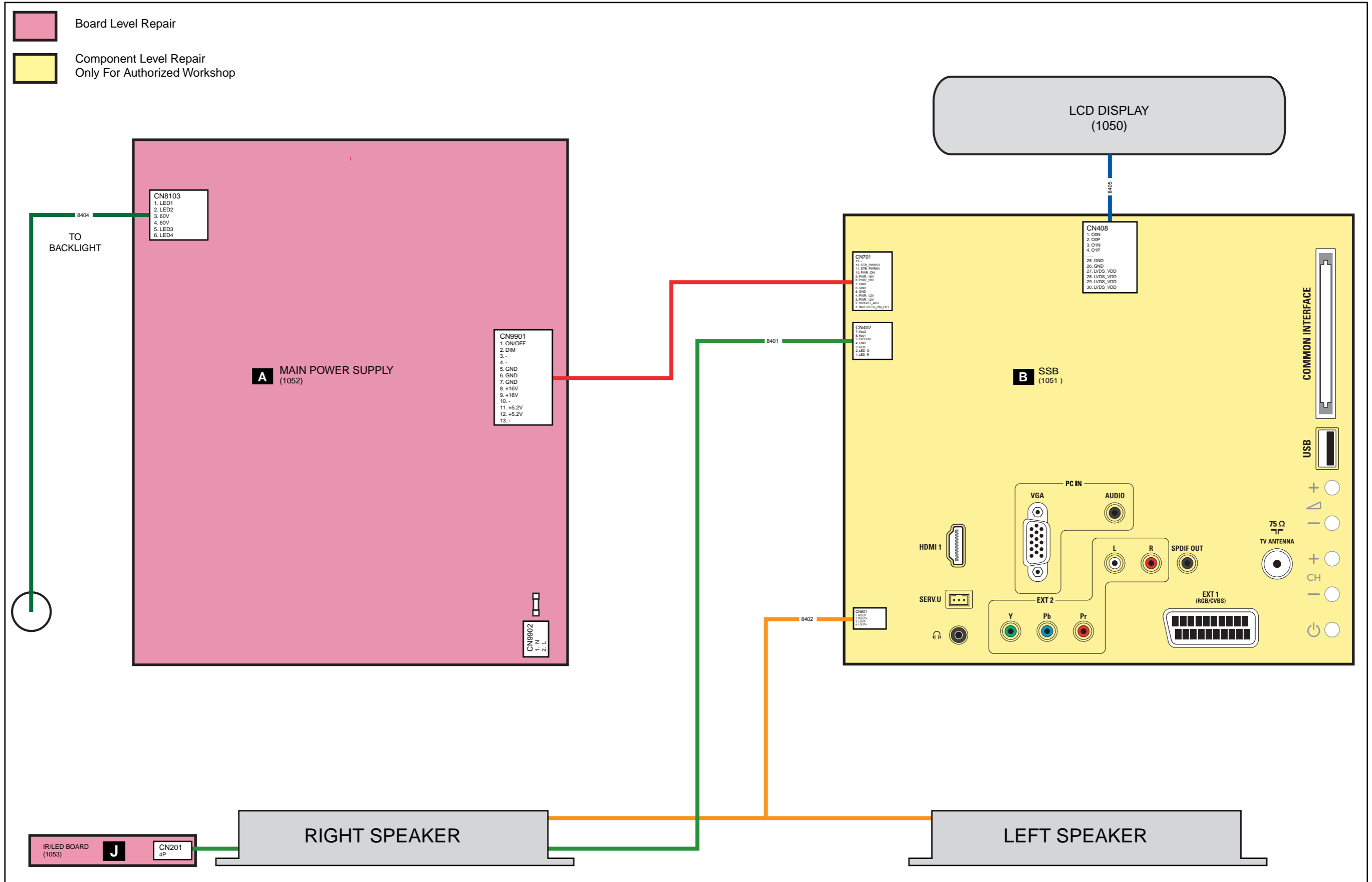



**9-4 Wiring diagram 26" Golden horse**

WIRING DIAGRAM 26" (Golden horse)

- Board Level Repair
- Component Level Repair  
Only For Authorized Workshop

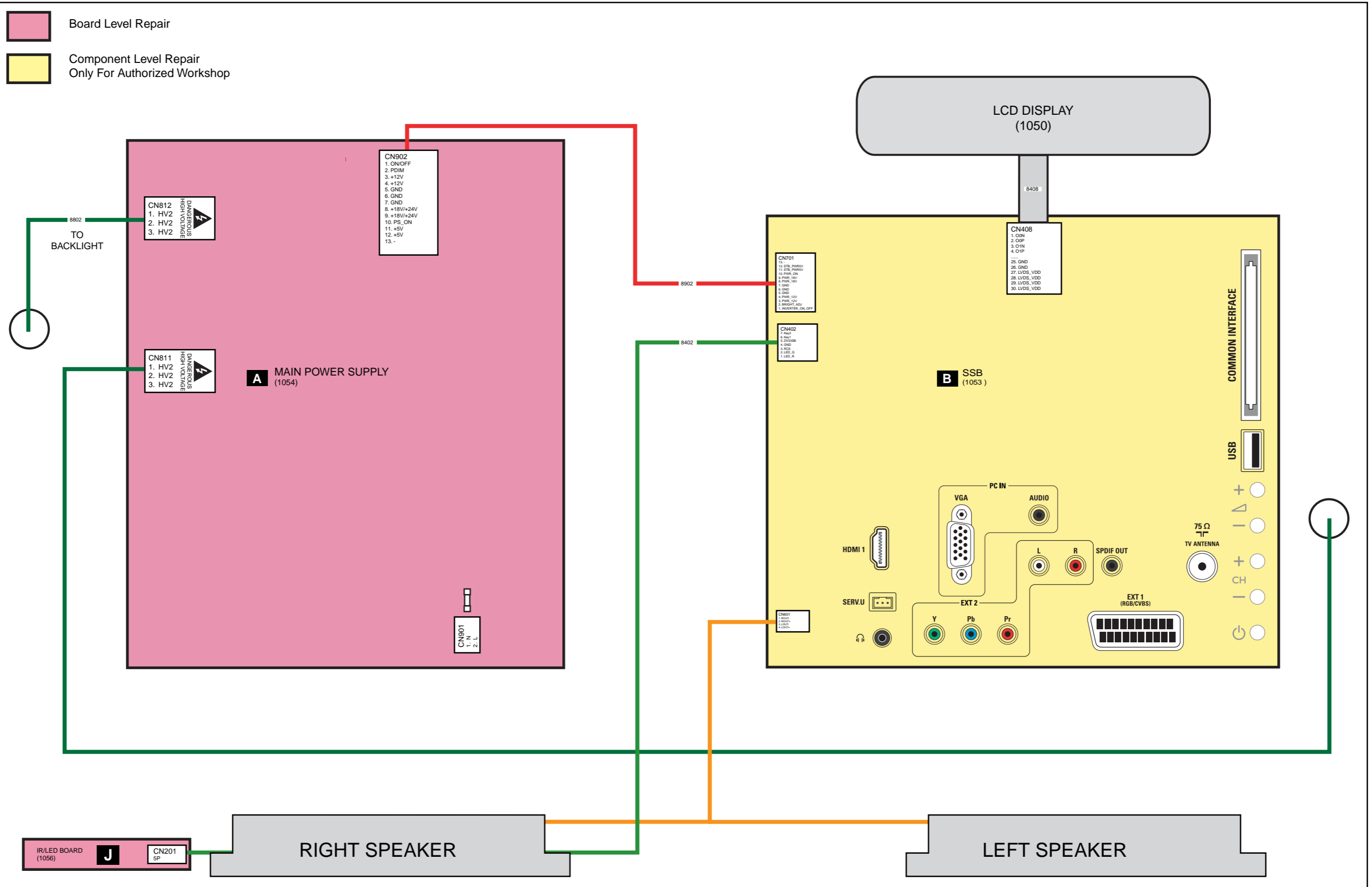

19120\_402\_110526.eps  
110527

### 9-5 Wiring diagram 32" Spot Deal

WIRING DIAGRAM 32" (Spot Deal)

- Board Level Repair
- Component Level Repair  
Only For Authorized Workshop

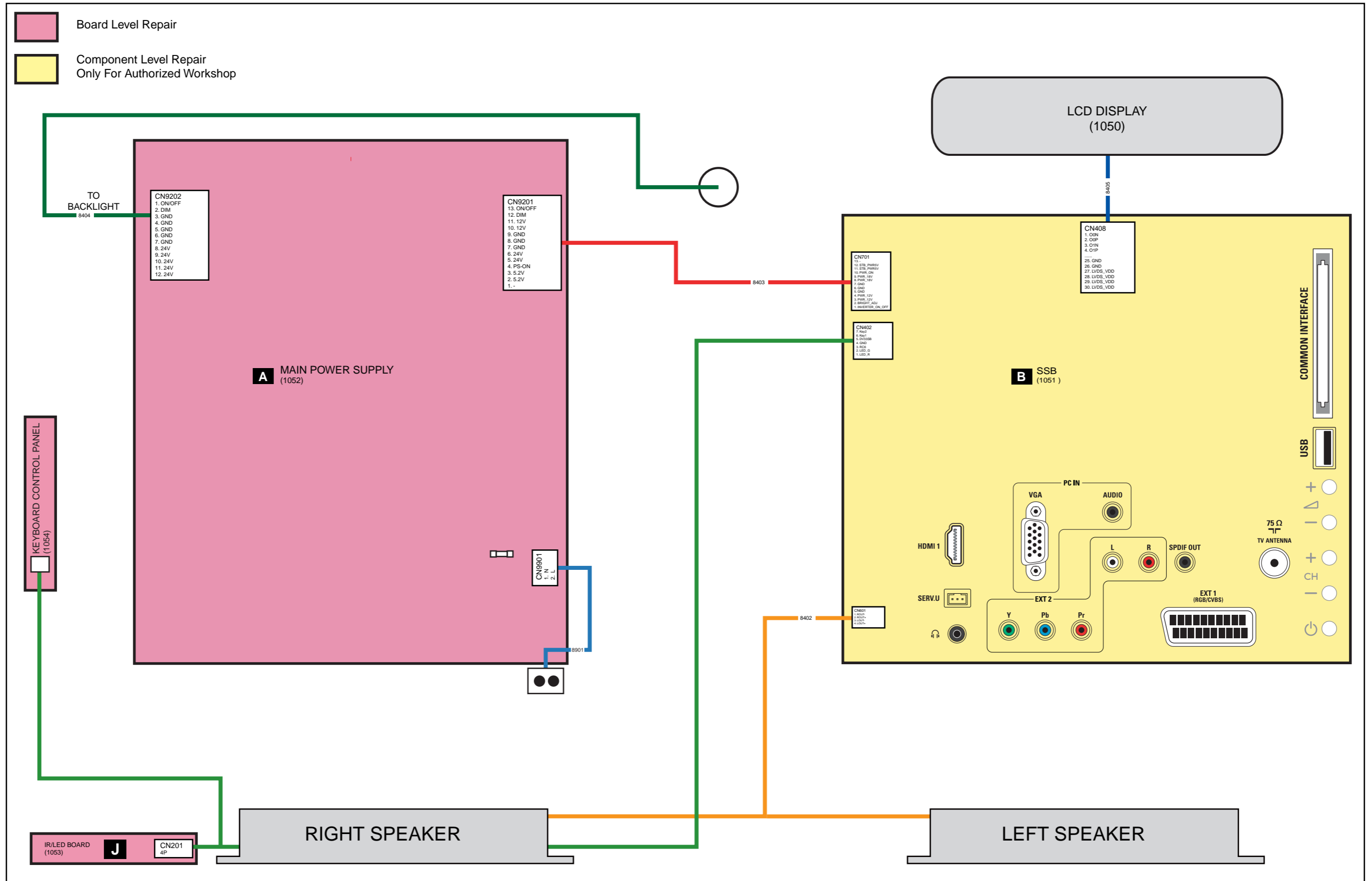

19121\_401\_110914.eps  
110919

**Block Diagram**

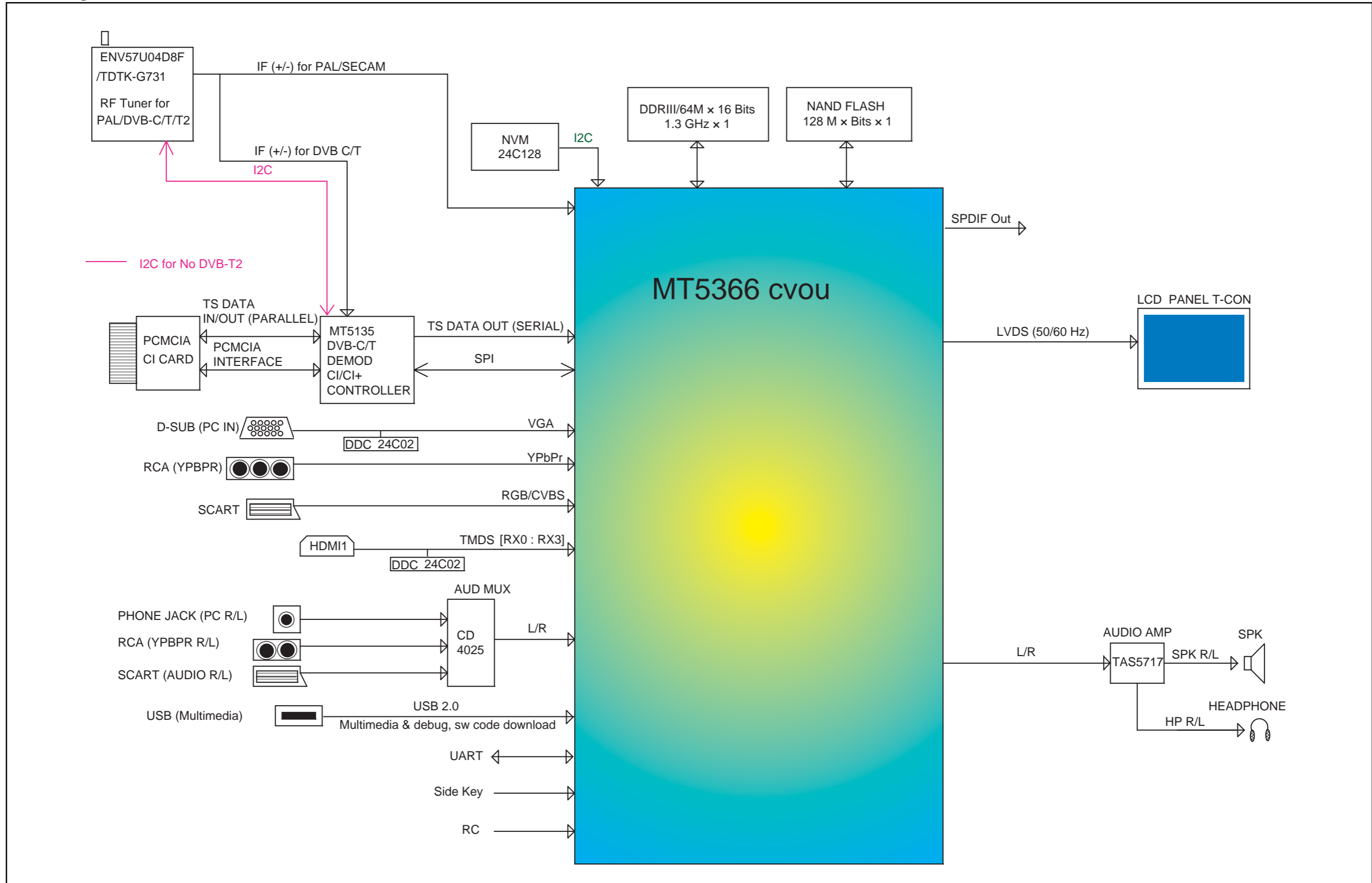

19120\_403\_110519.eps  
110526

# 10. Circuit Diagrams and PWB Layouts

10-1 A01 715G4899 PSU 19" and 22" Adapter

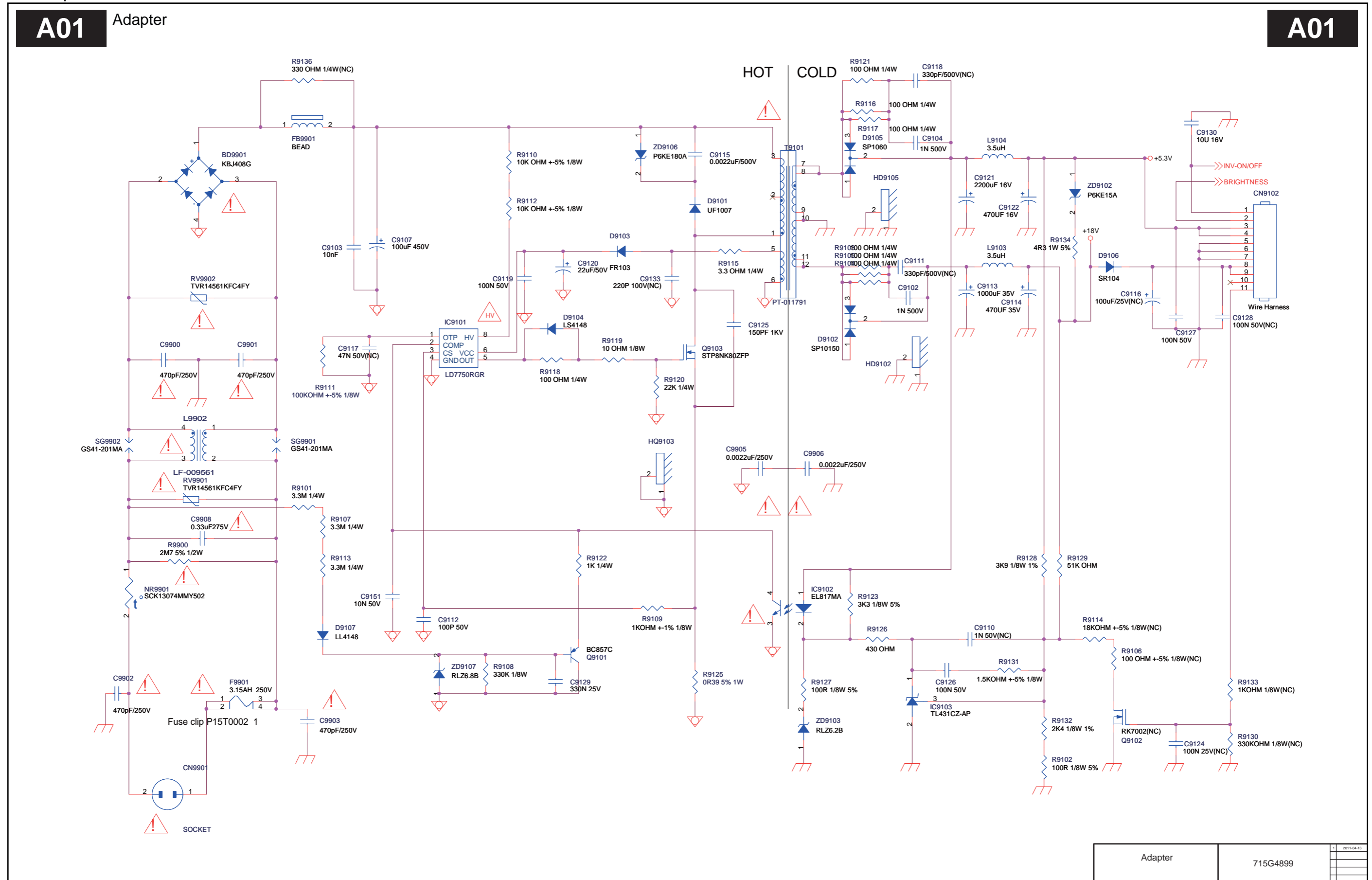

Inverter

A02

Inverter

A02

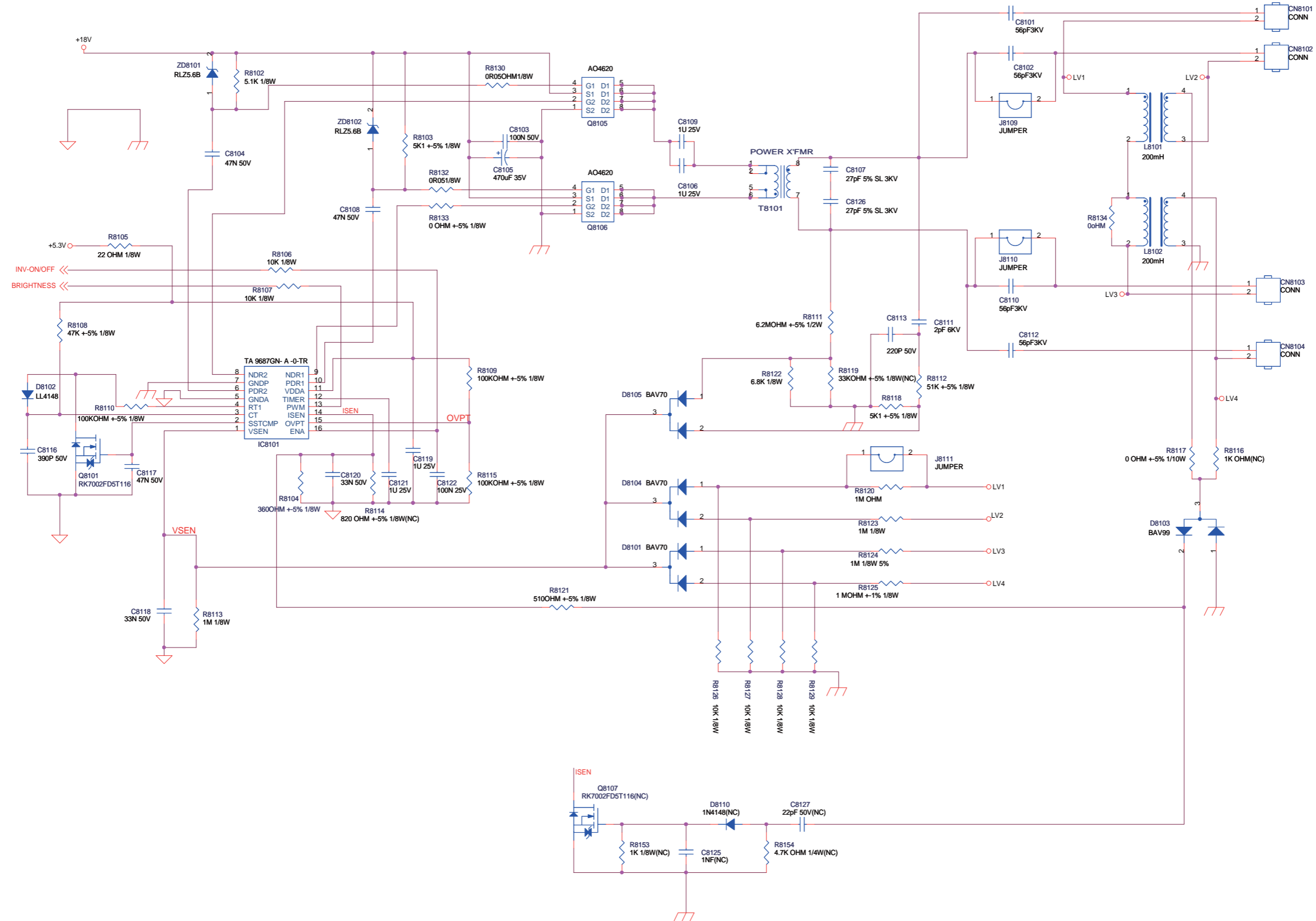

Inverter	715G4899	1	2011-04-13



Power layout top

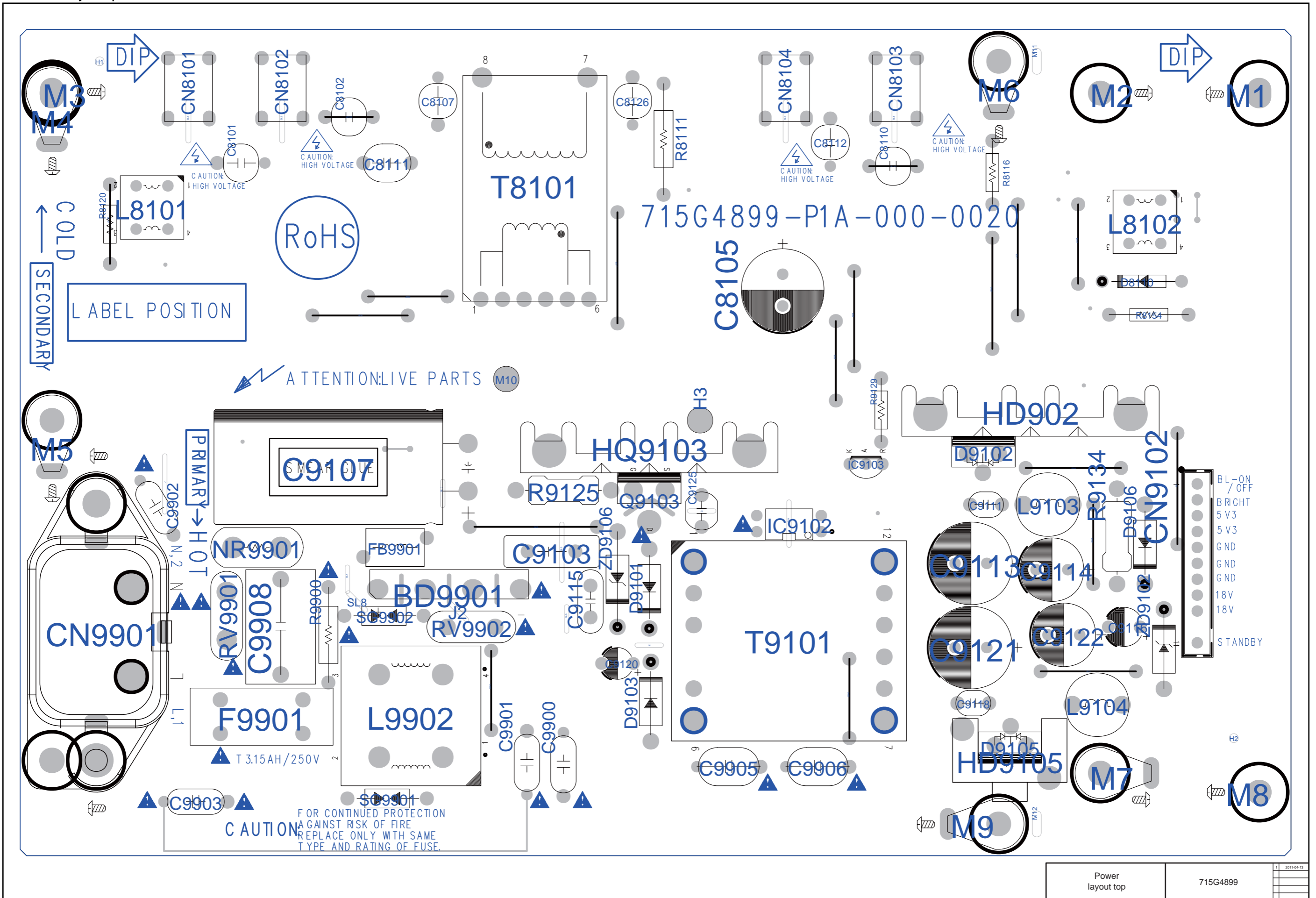

SECONDRARY  
COLD  
L8101  
LABEL POSITION

RoHS

715G4899-P1A-000-0020

ATTENTION: LIVE PARTS

PRIMARY  
HOT

CAUTION  
FOR CONTINUED PROTECTION  
AGAINST RISK OF FIRE  
REPLACE ONLY WITH SAME  
TYPE AND RATING OF FUSE.

- BL-ON / OFF
- BRIGHT
- 5 V3
- 5 V3
- GND
- GND
- 18V
- 18V
- STANDBY

Power layout top	715G4899	110517
		110517

Power layout bottom

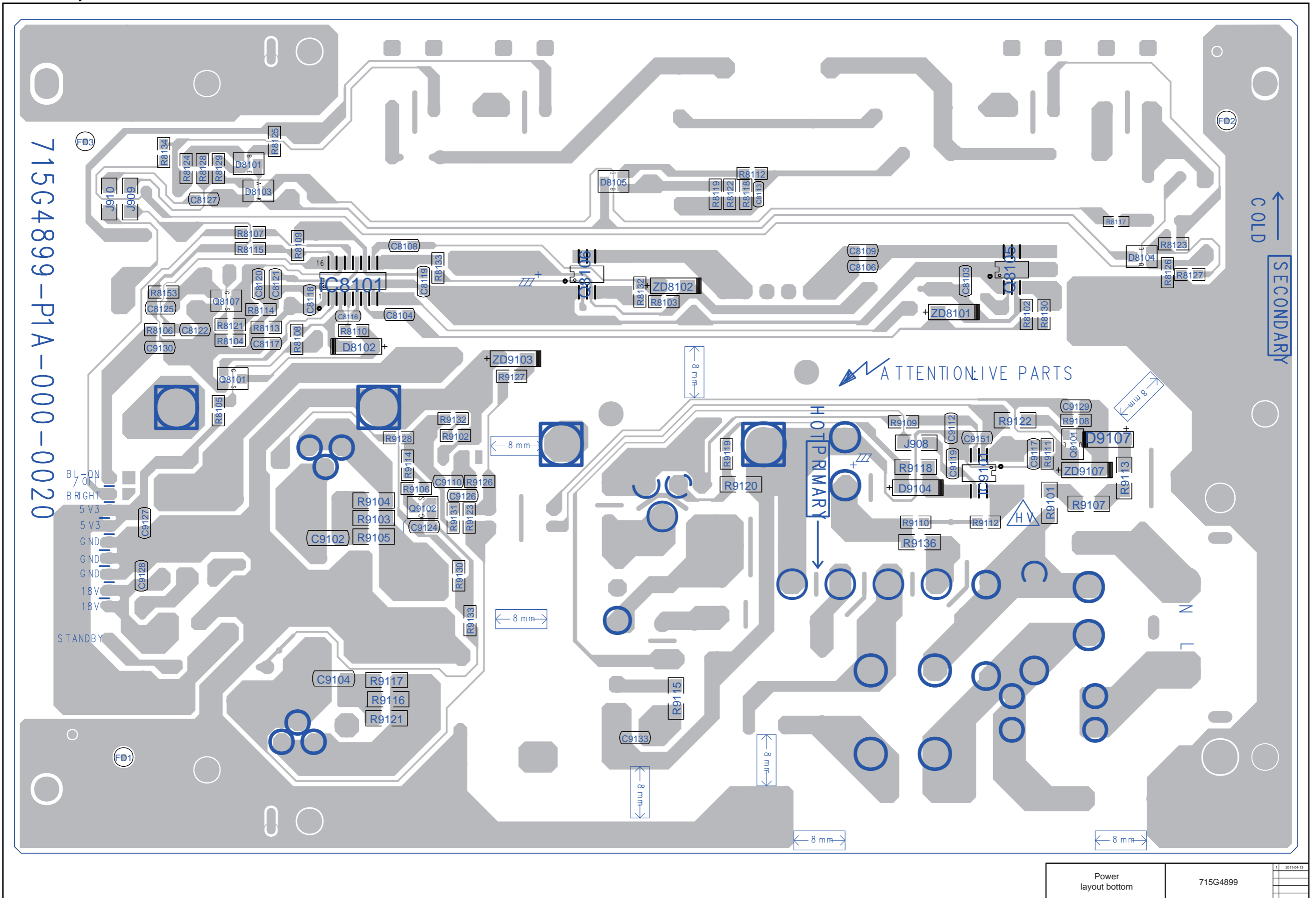

Power layout bottom	715G4899	110518
		110518

10-2 A01 715G5043 PSU 26"  
Inverter

**A01** Inverter

**A01**

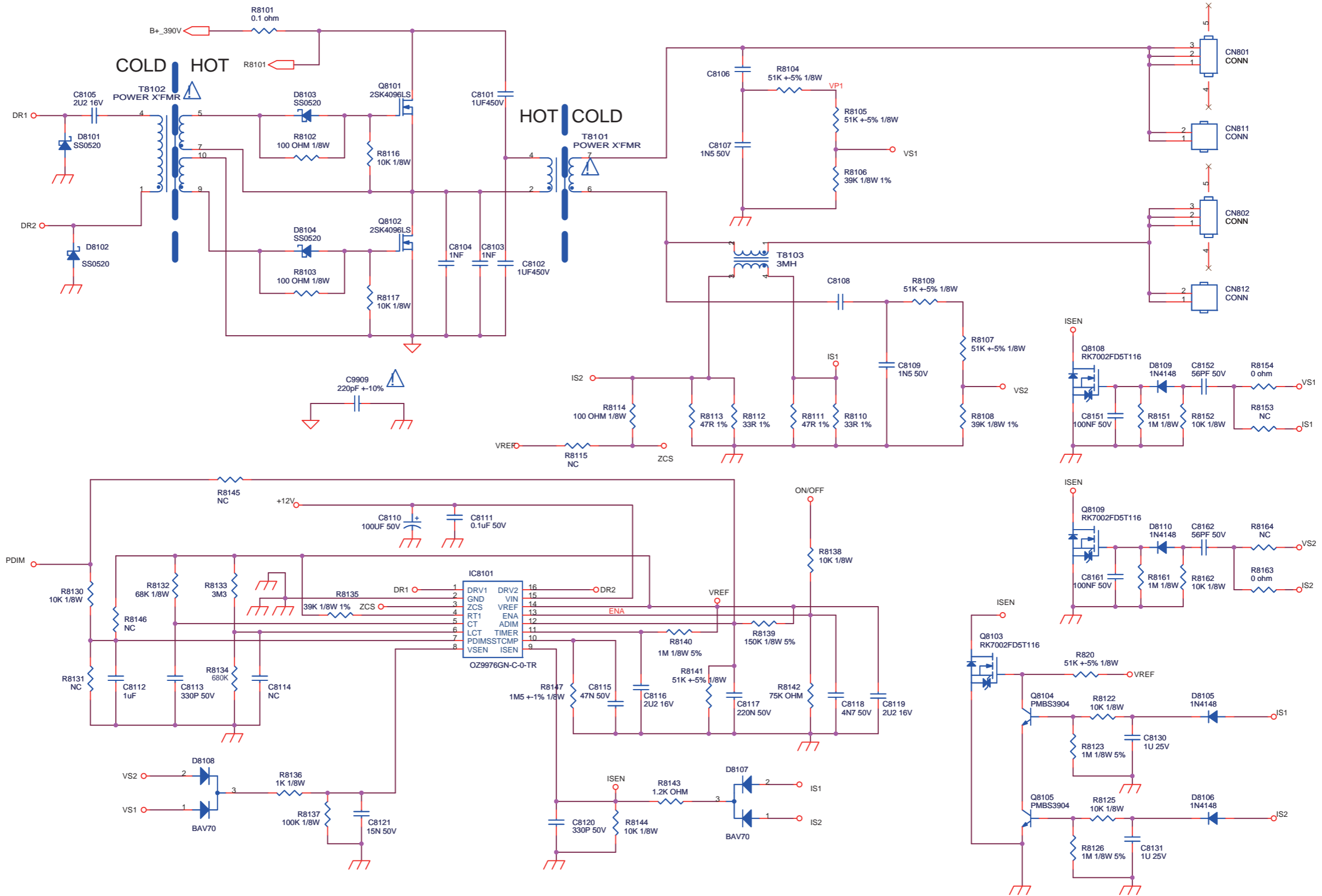

Inverter	715G5043	1	2011-05-16

Power

A02

Power

A02

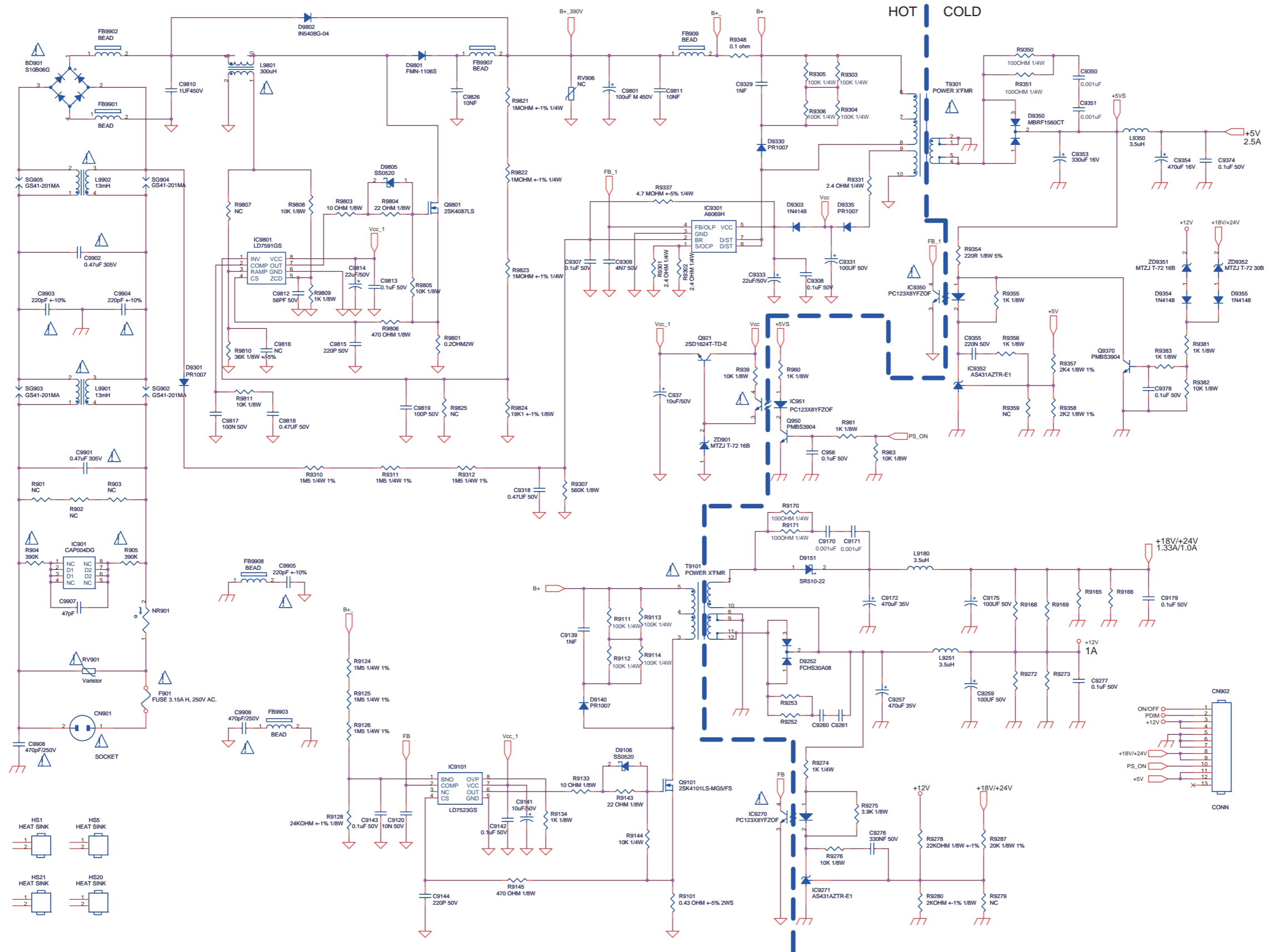

Power	715G5043	1	2011-05-18
		2	
		3	
		4	
		5	
		6	
		7	
		8	
		9	
		10	
		11	
		12	
		13	

Power layout top

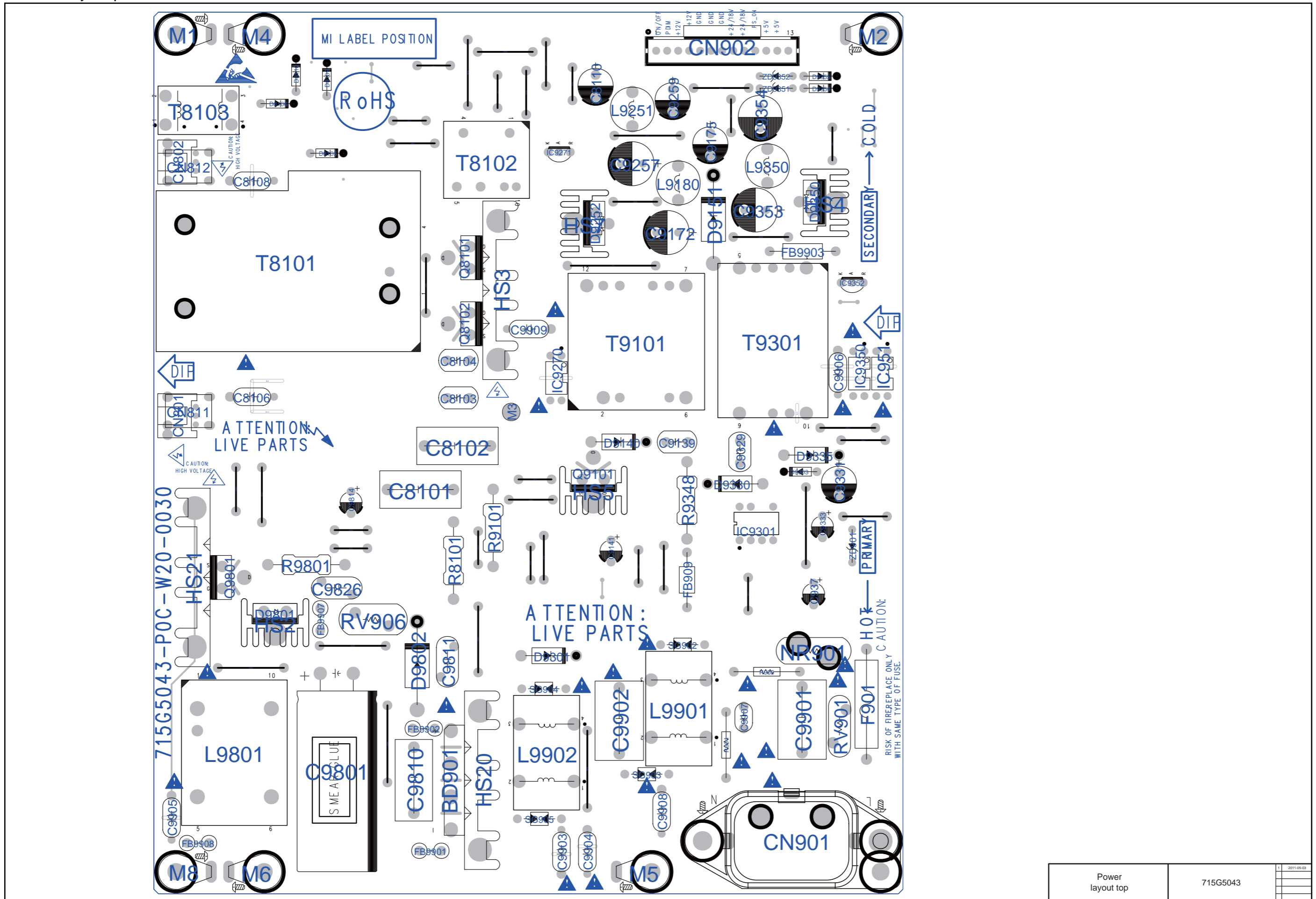

Power layout top	715G5043	110518
		110518



Power layout bottom

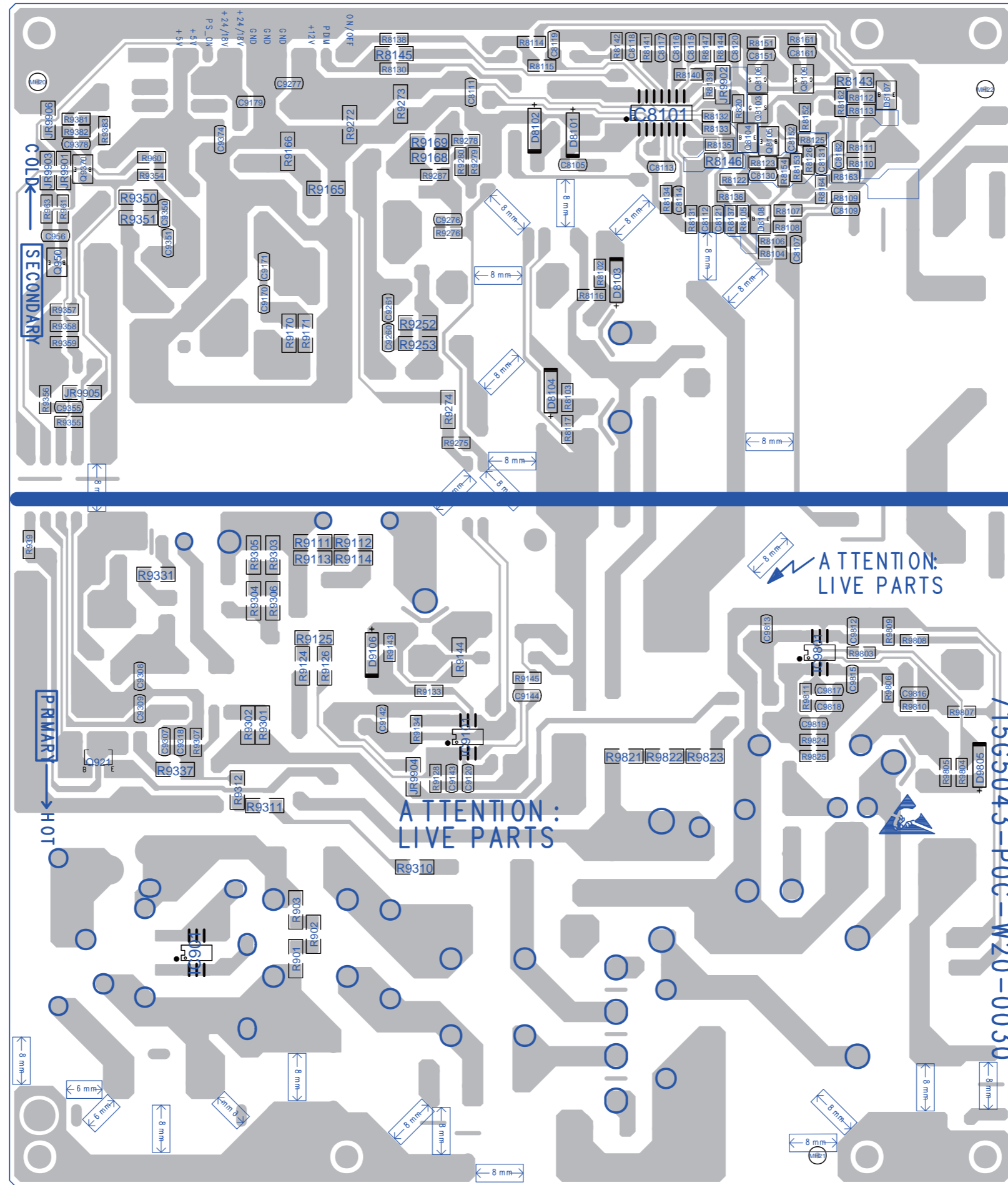

Power layout bottom	715G5043	1	2011-08-03

10-3 A01 715G5147 PSU Spot Deal 22"

Power

A01

Power

A01

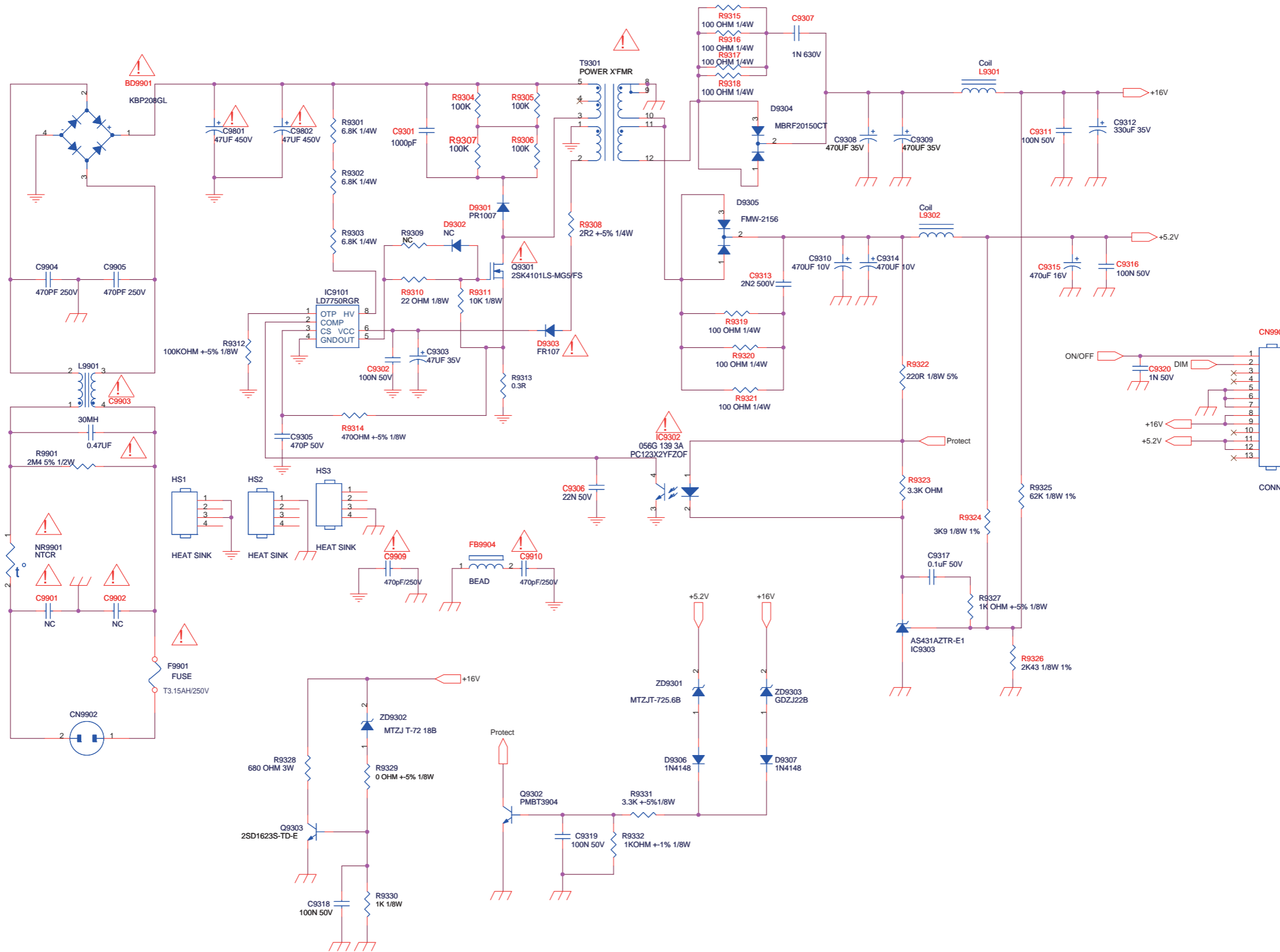

POWER	715G5147	1A	2011-07-21

LED driver

A02

LED driver

A02

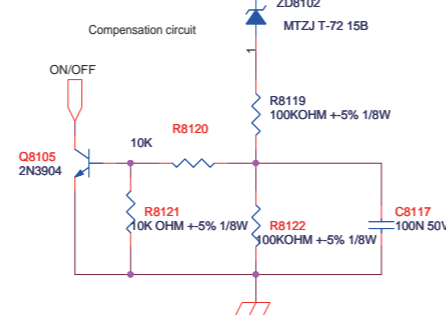
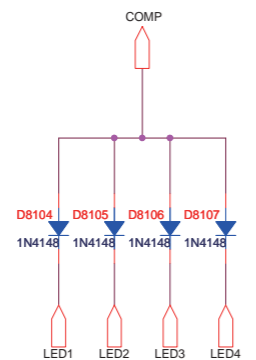
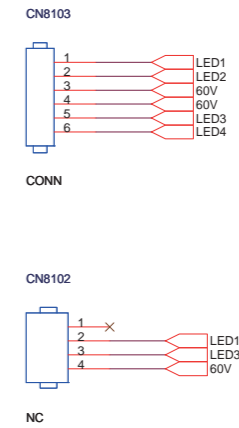
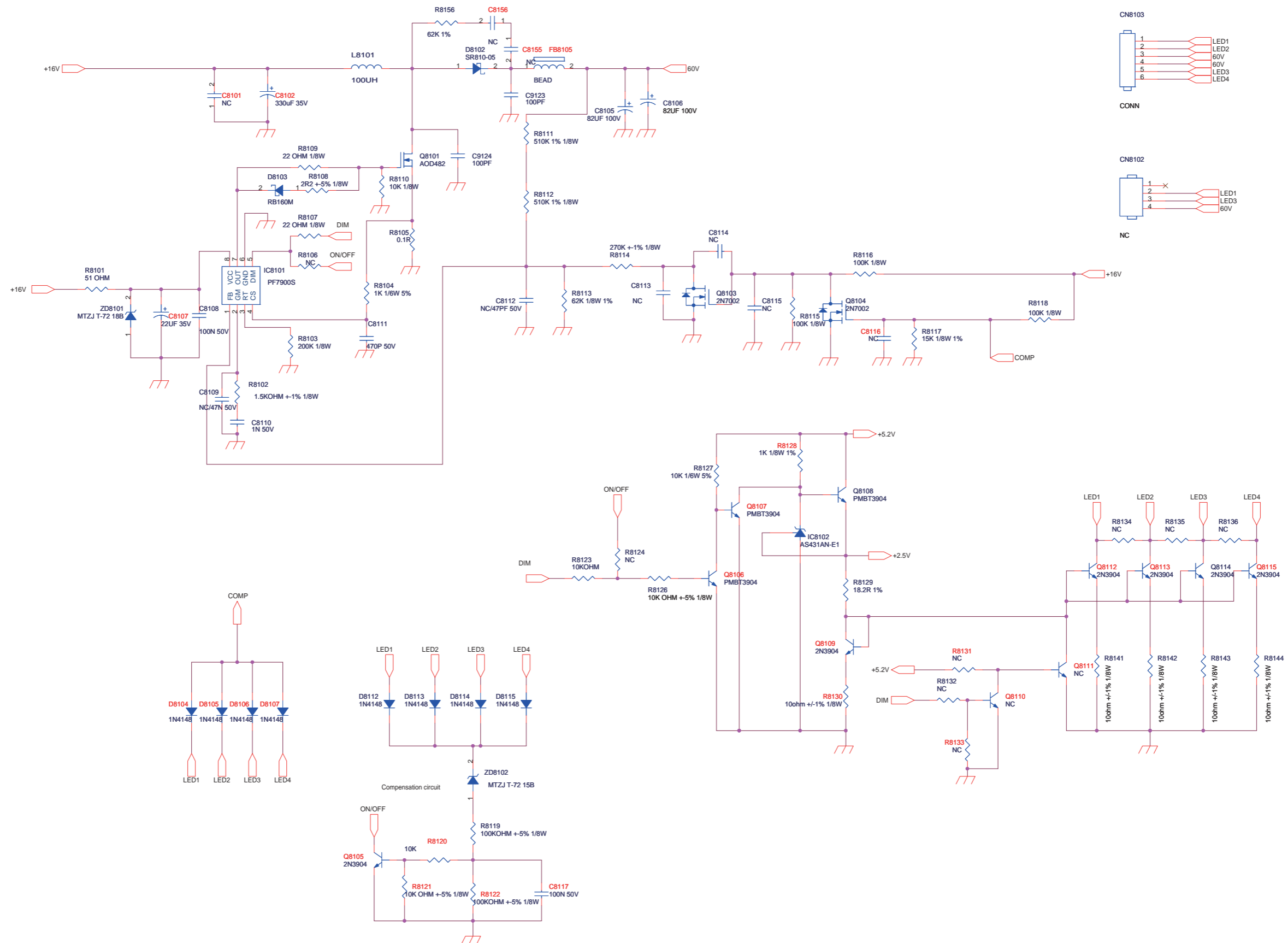

LED DRIVER	715G5147	1A	2011-07-21

Power layout top

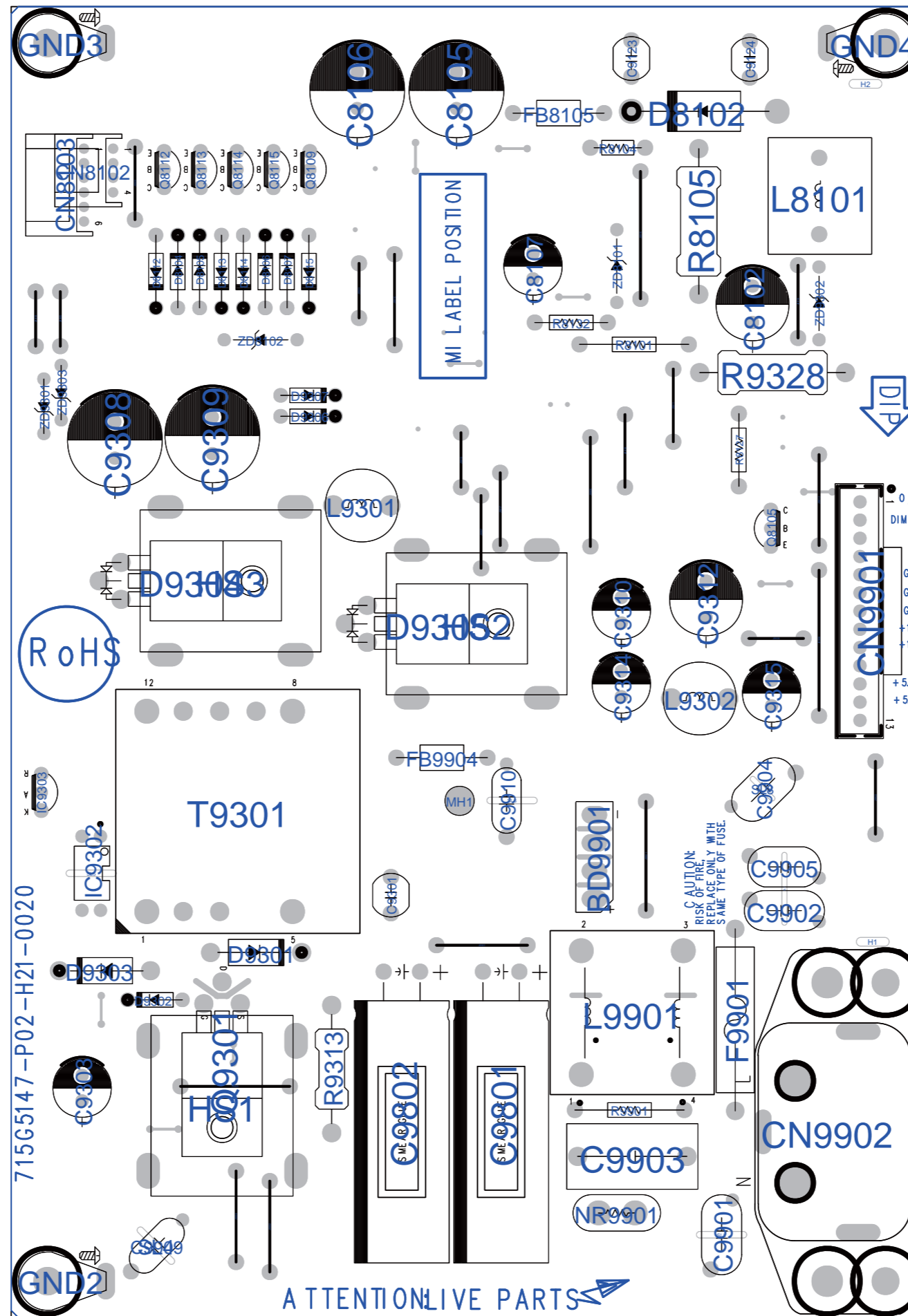

Power layout top	715G5147	11	2011-07-21
		12	
		13	
		14	

Power layout bottom

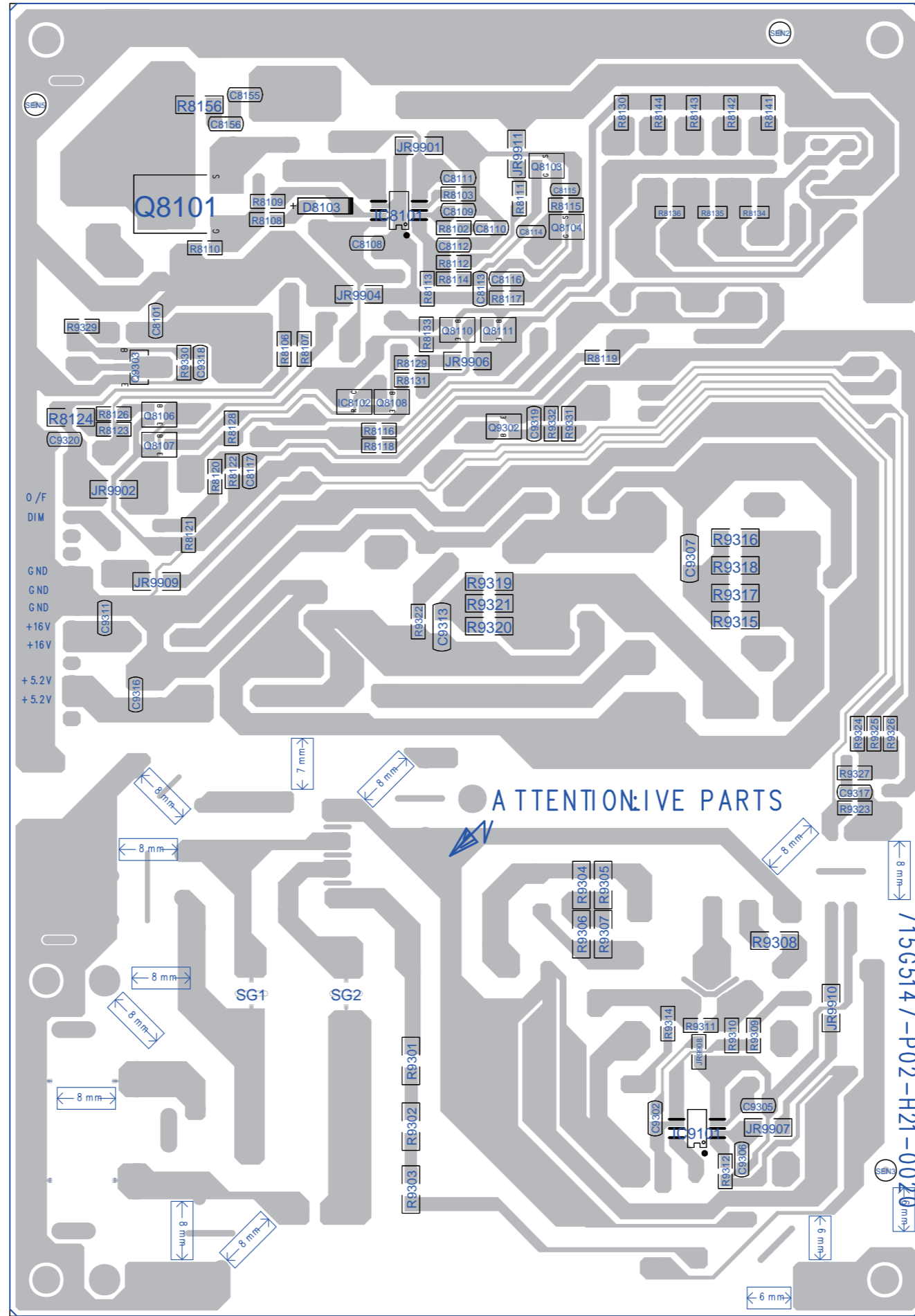

Power layout bottom	715G5147	2011-07-21



10-4 A01 715G4697 PSU Spot Deal 32"

AC side

A01

AC side

A01

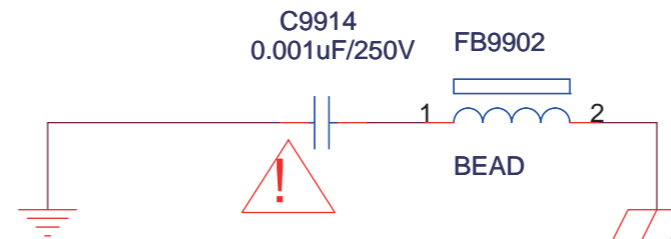
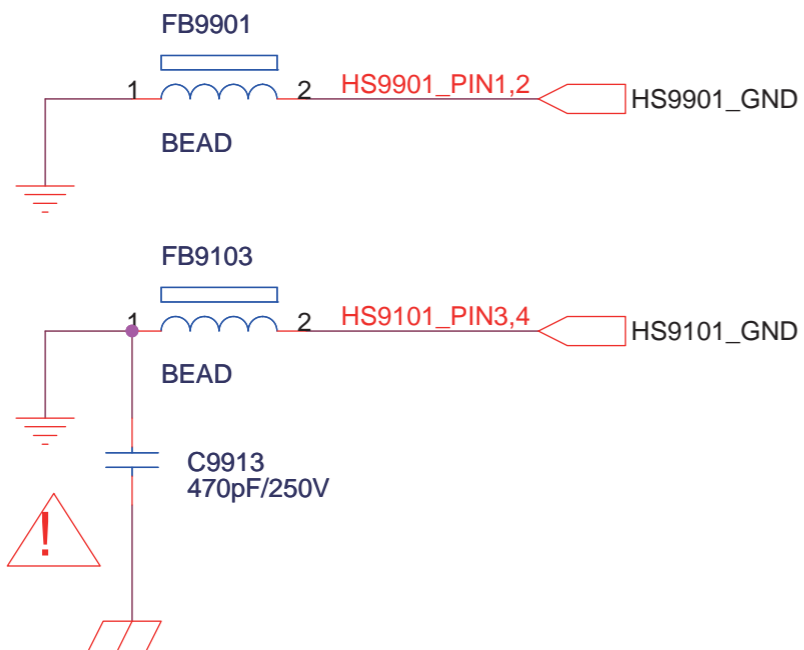
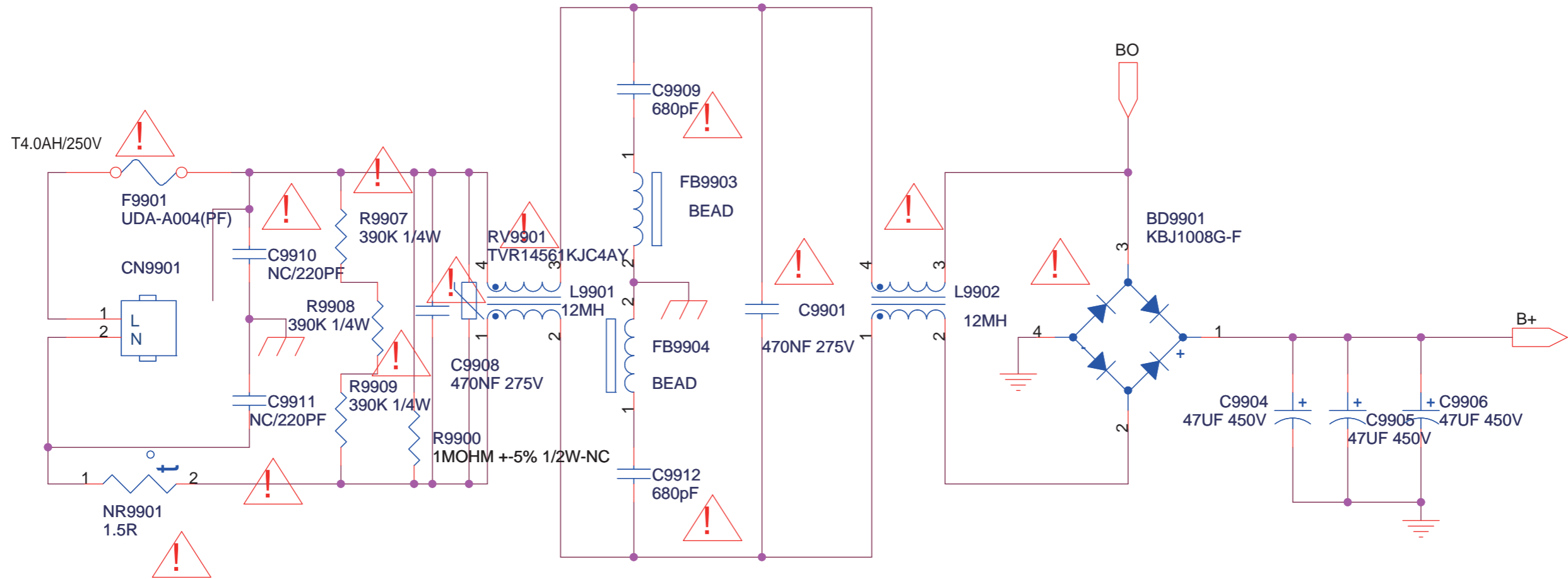

AC side	715G4697	A	2011-06-16

Standby

**A02**

Standby

**A02**

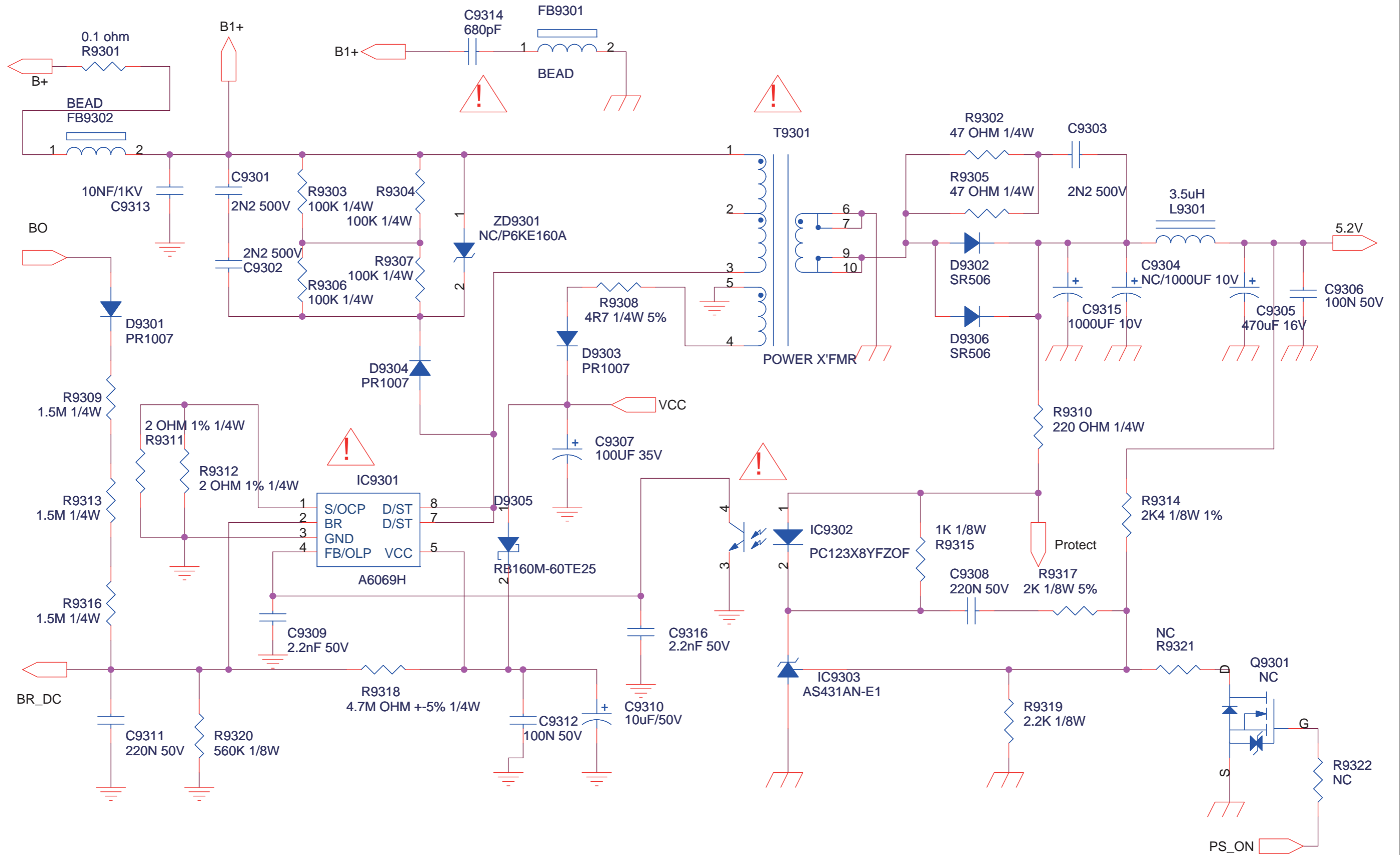

Standby	715G4697	A	2011-06-16

Secondary power

A03

Secondary power

A03

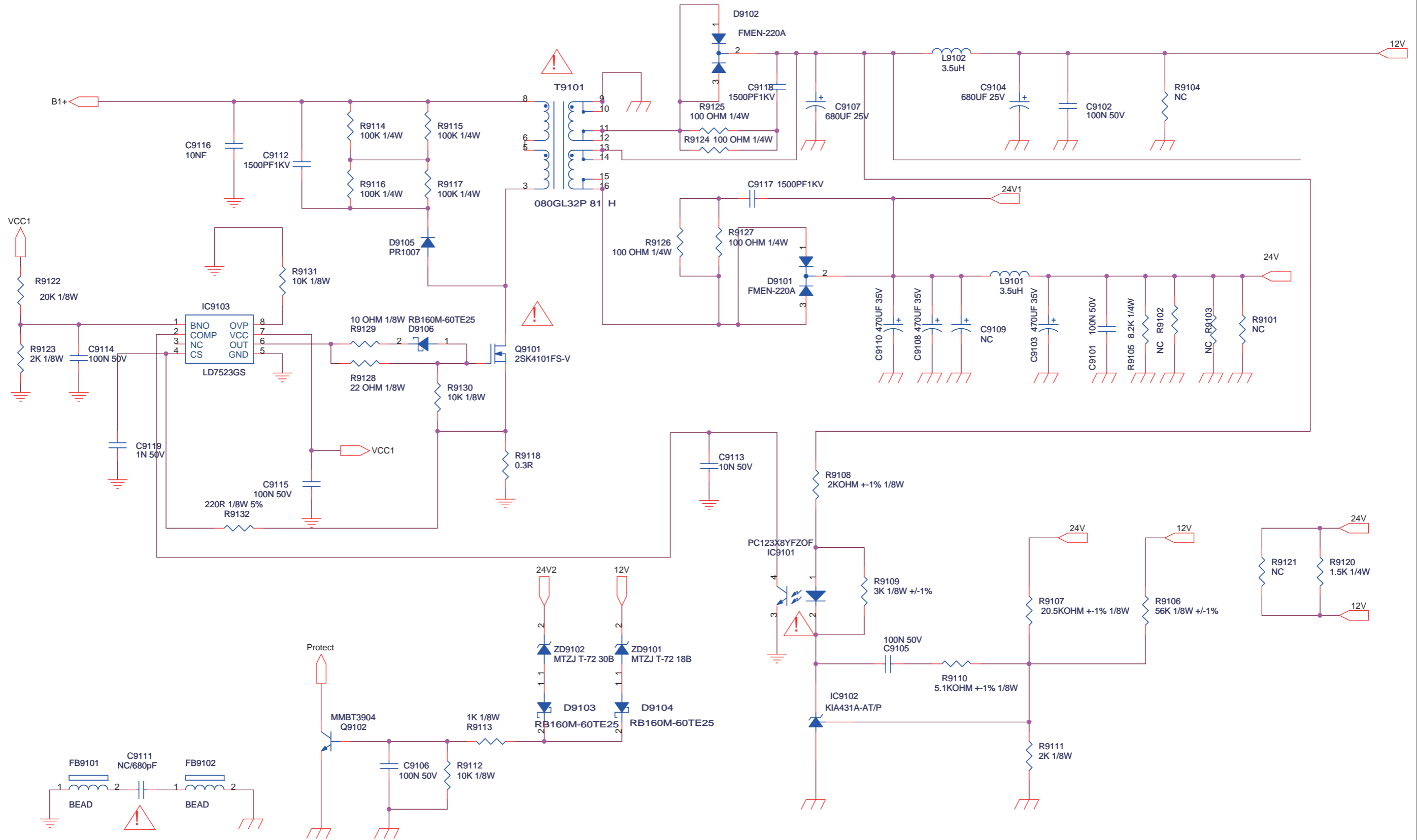

Secondary power	715G4697	A	2011-06-16

19121\_506\_110914.eps  
110921

Main power

**A04**

Main power

**A04**

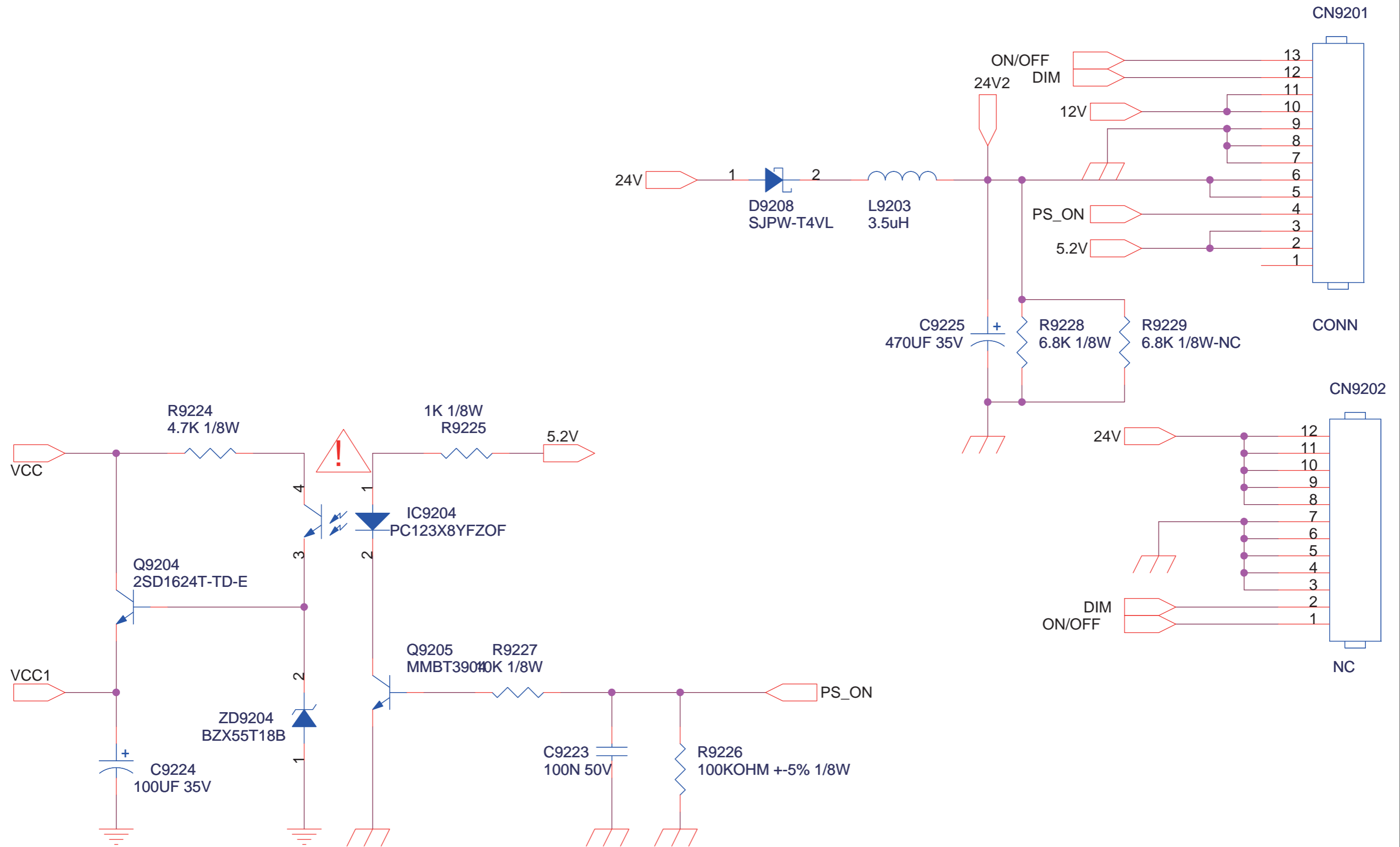

Main power	715G4697	A	2011-06-16

LED driver

A05

LED driver

A05

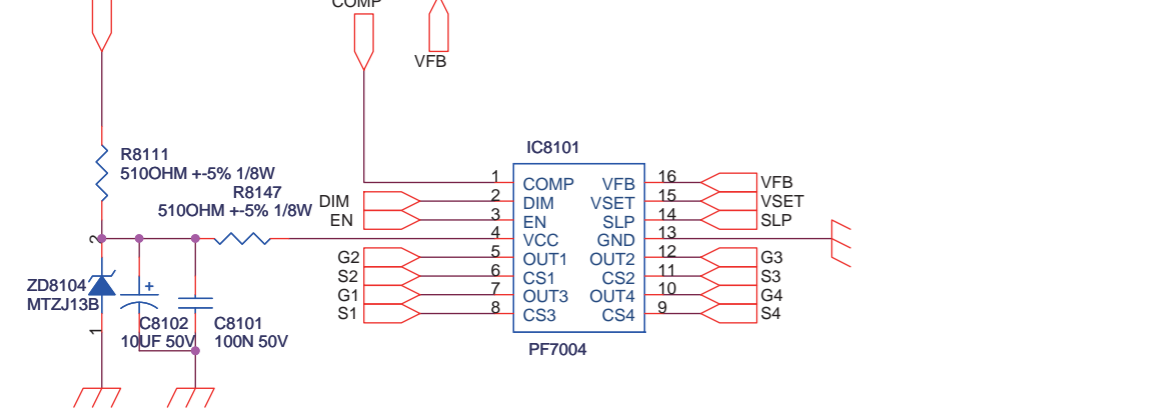
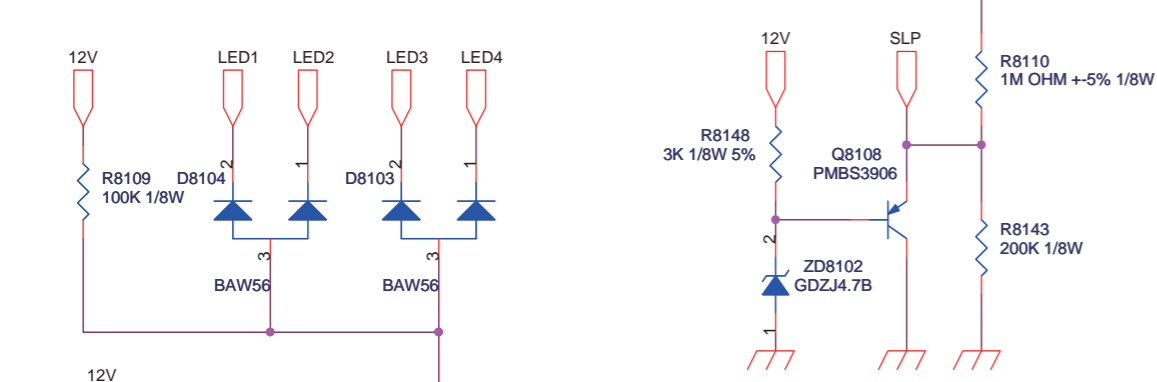
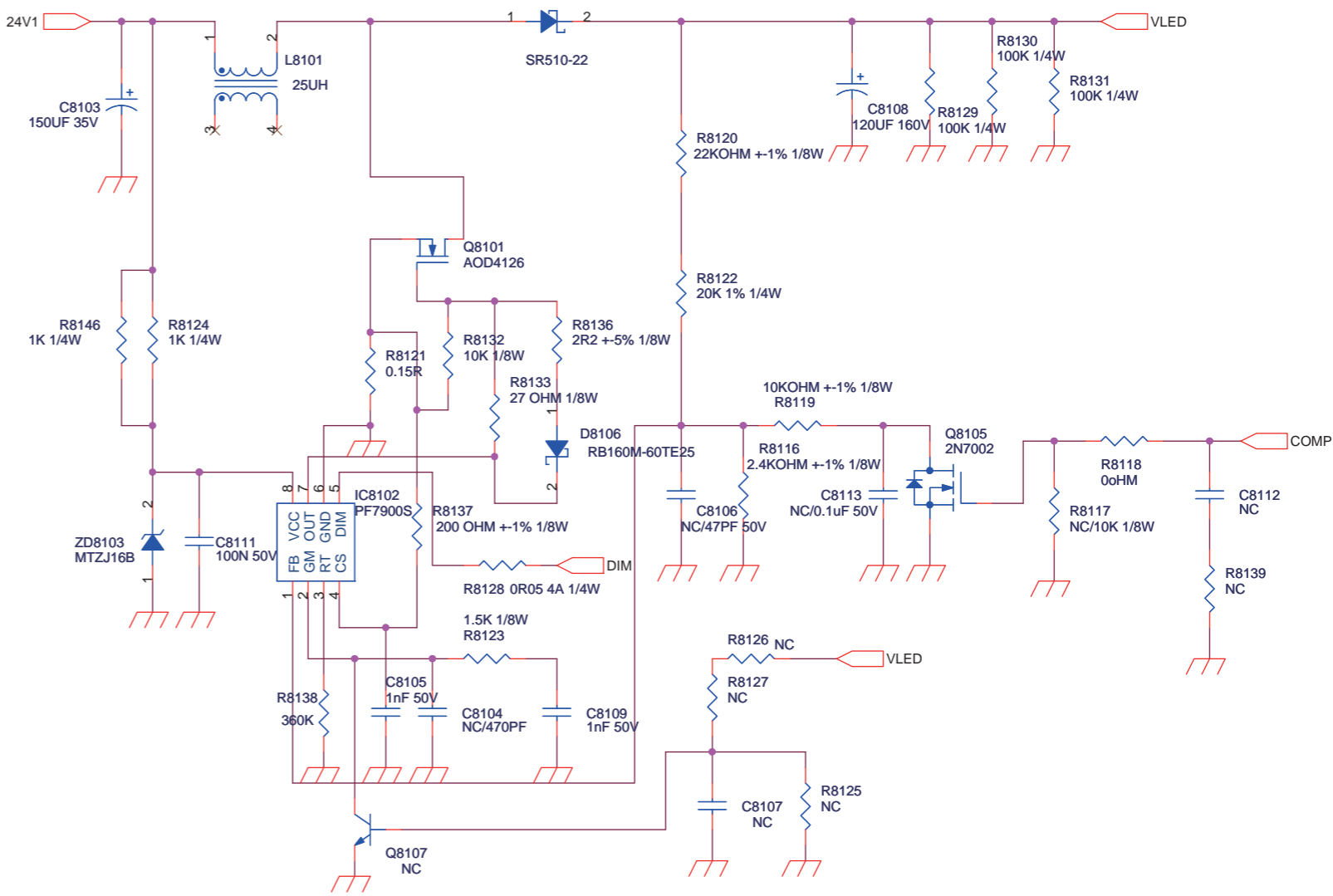
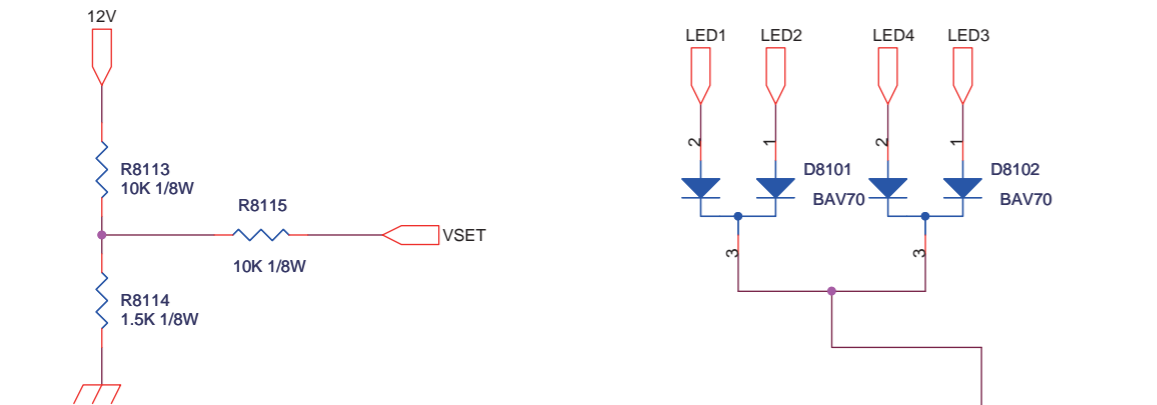
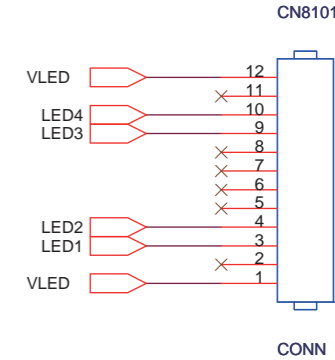
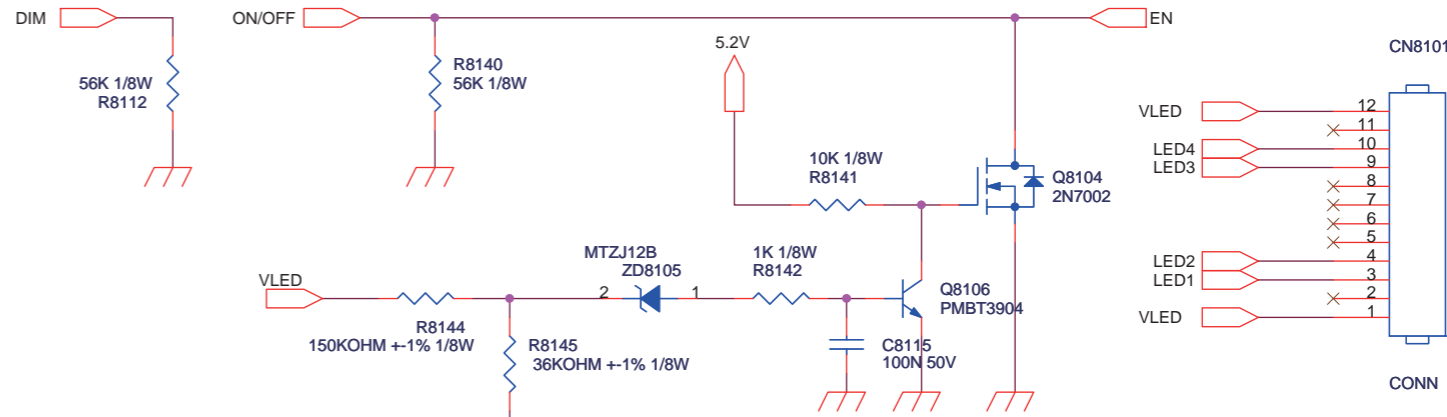
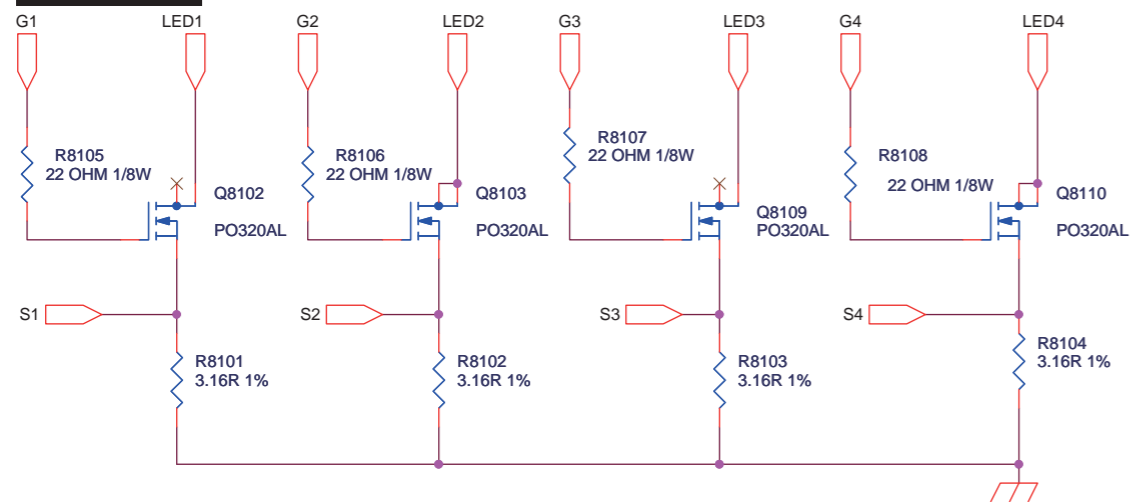

LED driver	715G4697	A	2011-09-18



Power layout top

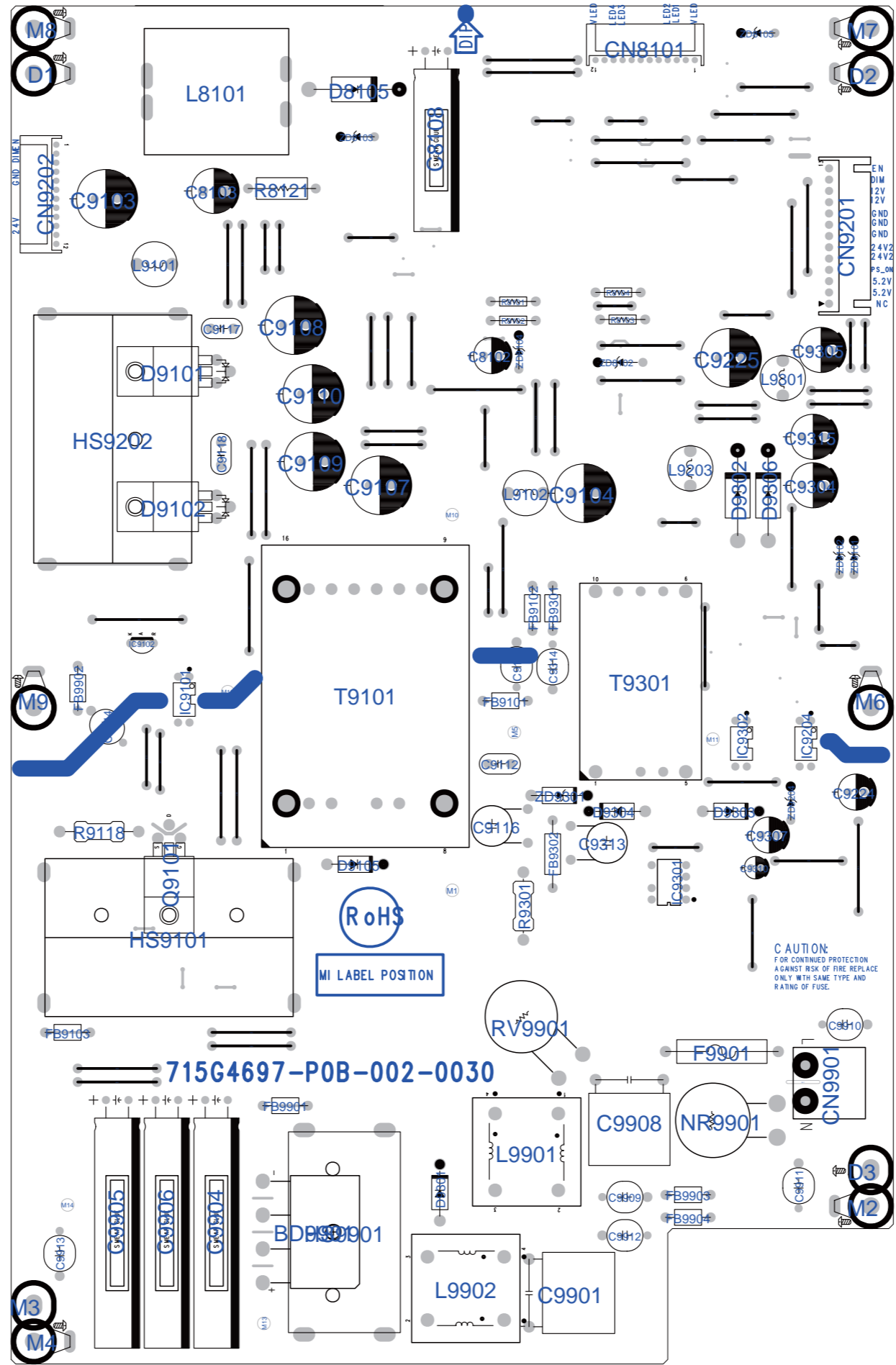

Power layout top	715G4697	A	2011-06-16

Power layout bottom

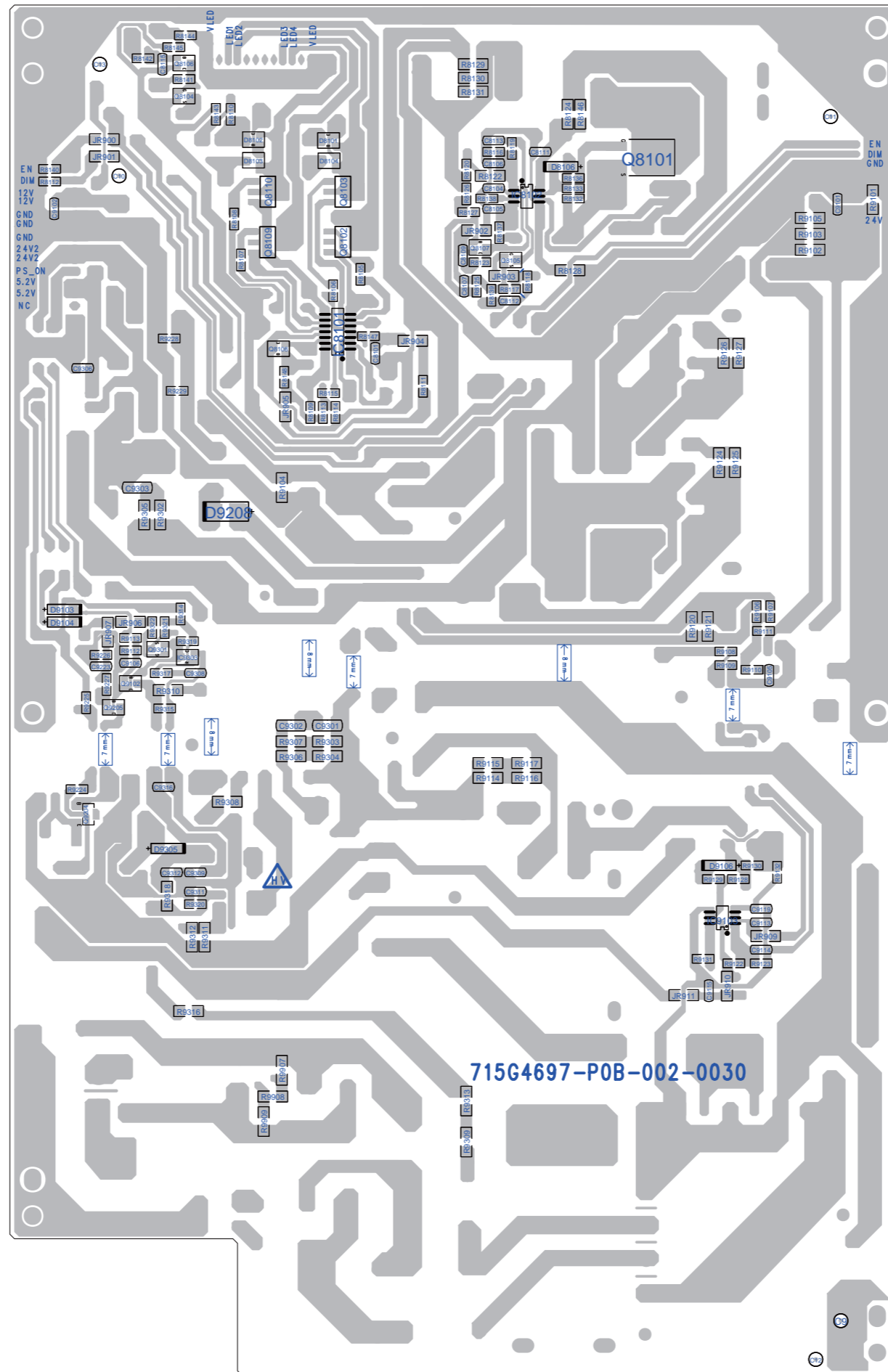

Power layout bottom	715G4697	A	2011-06-16

10-5 B 715G4796 SSB  
Power-1

**B01** Power-1

**B01**

DC POWER INPUT

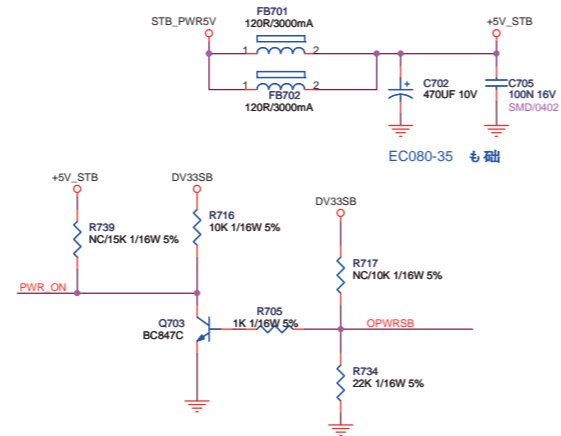
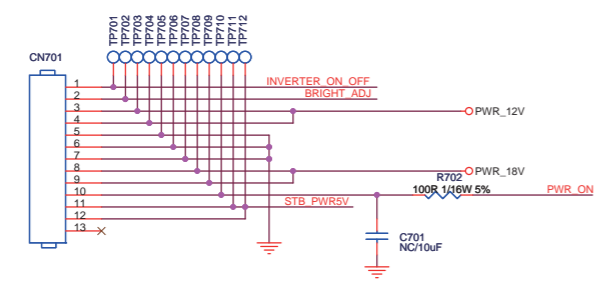

+5V\_STB to +5V\_SW

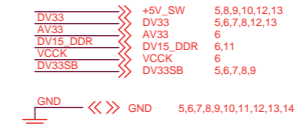
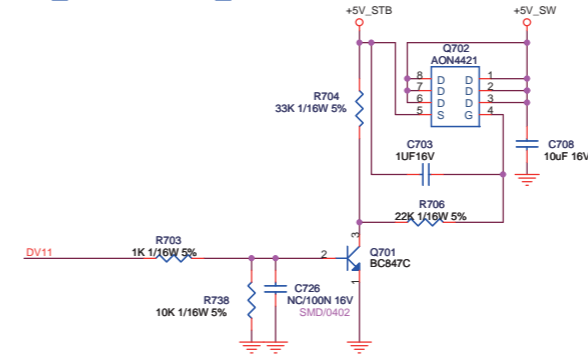

+5V\_STB to DV11/VCCK

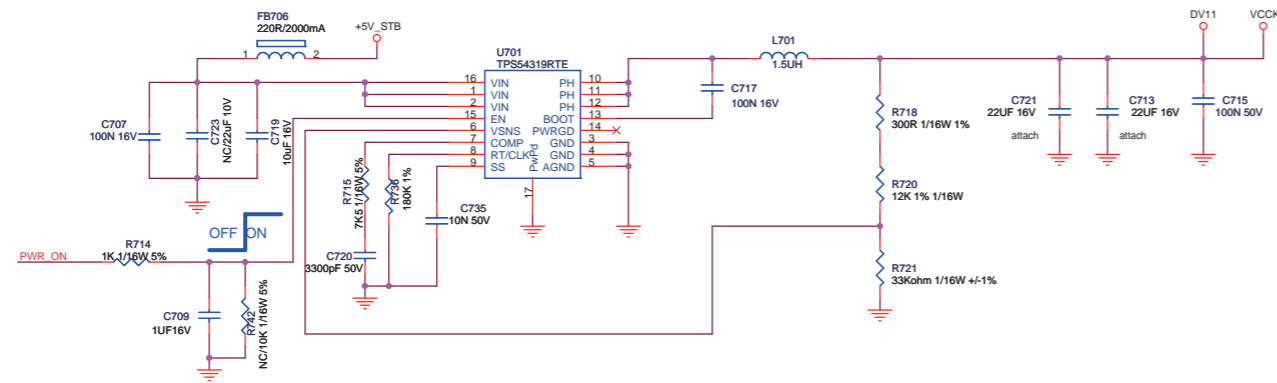

PWR\_18V to +18V control by PWR\_ON

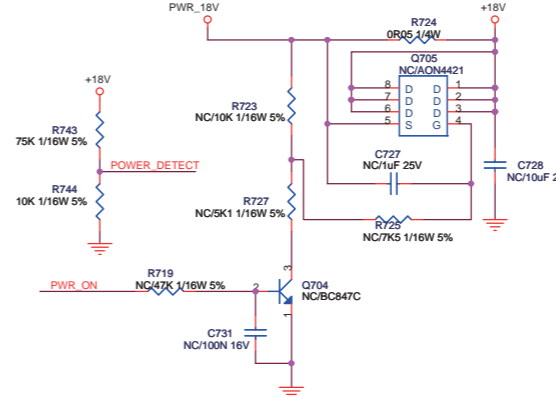

+5V\_SW to DV33/AV33

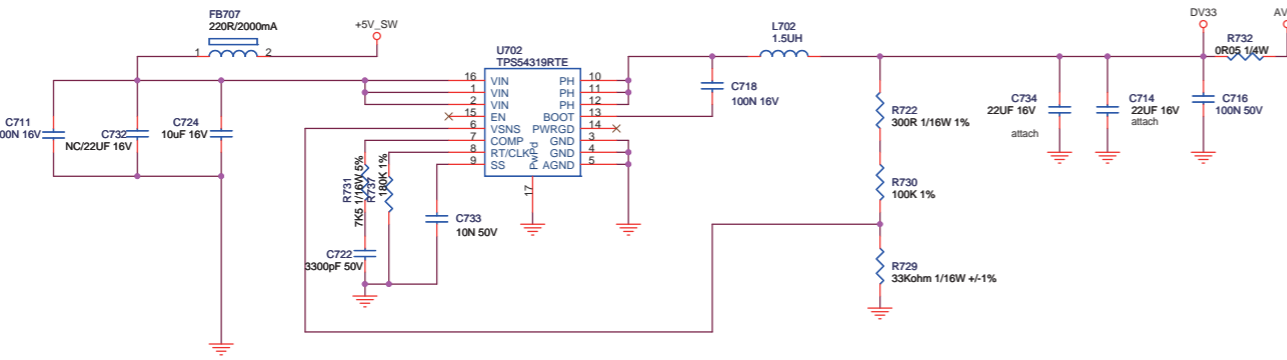

DV33 to DV15\_DDR

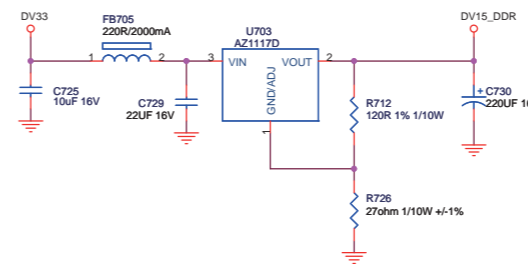

Power-1

715G4796

1 2011-05-17

+5V\_STB to DV33SB

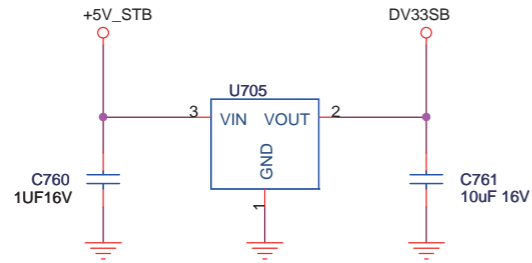

DV33 to AV12

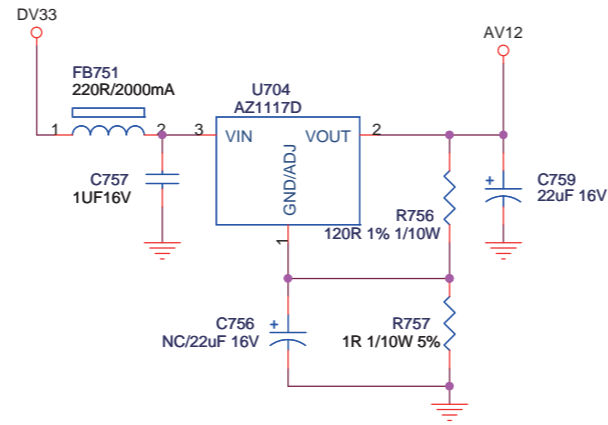

PWR_12V	>>	PWR_12V	4
+5V_STB	>>	+5V_STB	4,7
+5V_SW	>>	+5V_SW	4,8,9,10,12,13
+5V_TUNER	>>	+5V_TUNER	14
DV33	>>	DV33	4,6,7,8,12,13
DV33SB	>>	DV33SB	4,6,7,8,9
AV12	>>	AV12	6,13
PANEL_VCC	>>	PANEL_VCC	12
GND	<<	GND	4,6,7,8,9,10,11,12,13,14

GPIO Contrl

PANEL\_VCC\_ON/OFF << PANEL\_VCC\_ON/OFF 6

+5V\_SW to +5V\_TUNER

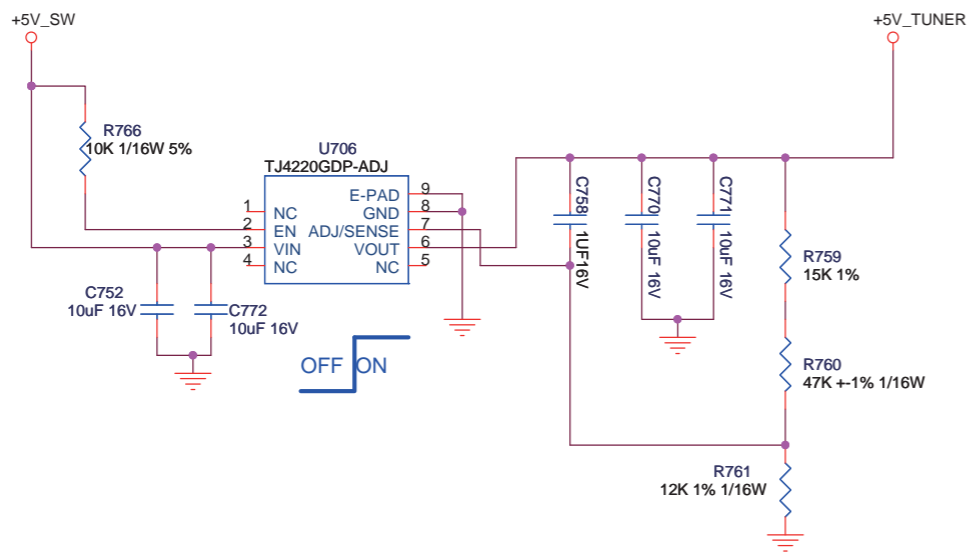

PANEL\_VCC

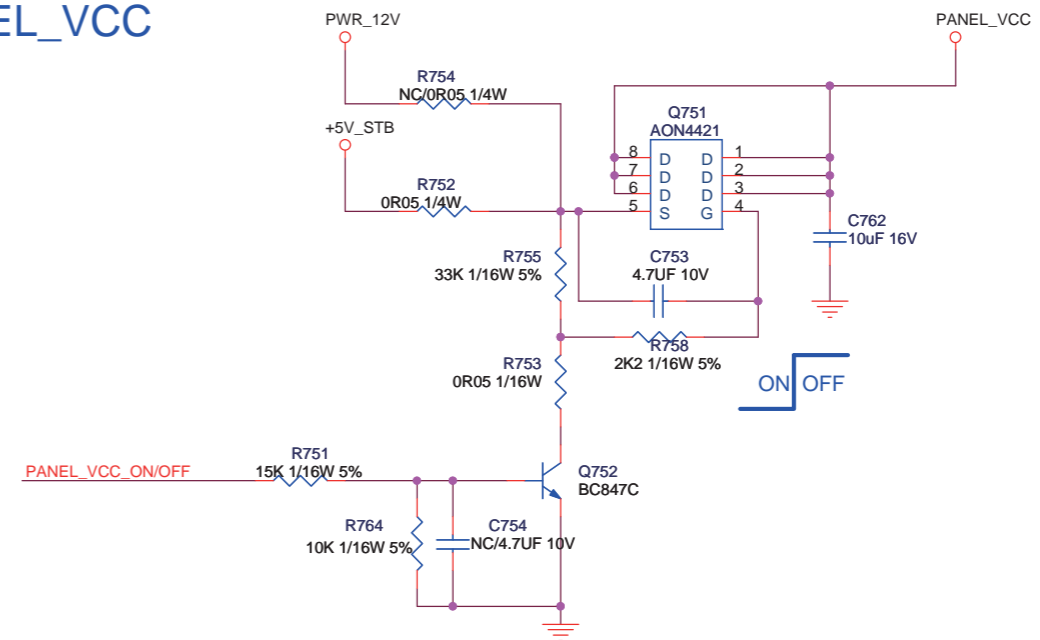

MT5366 cvou

B03

MT5366 cvou

B03

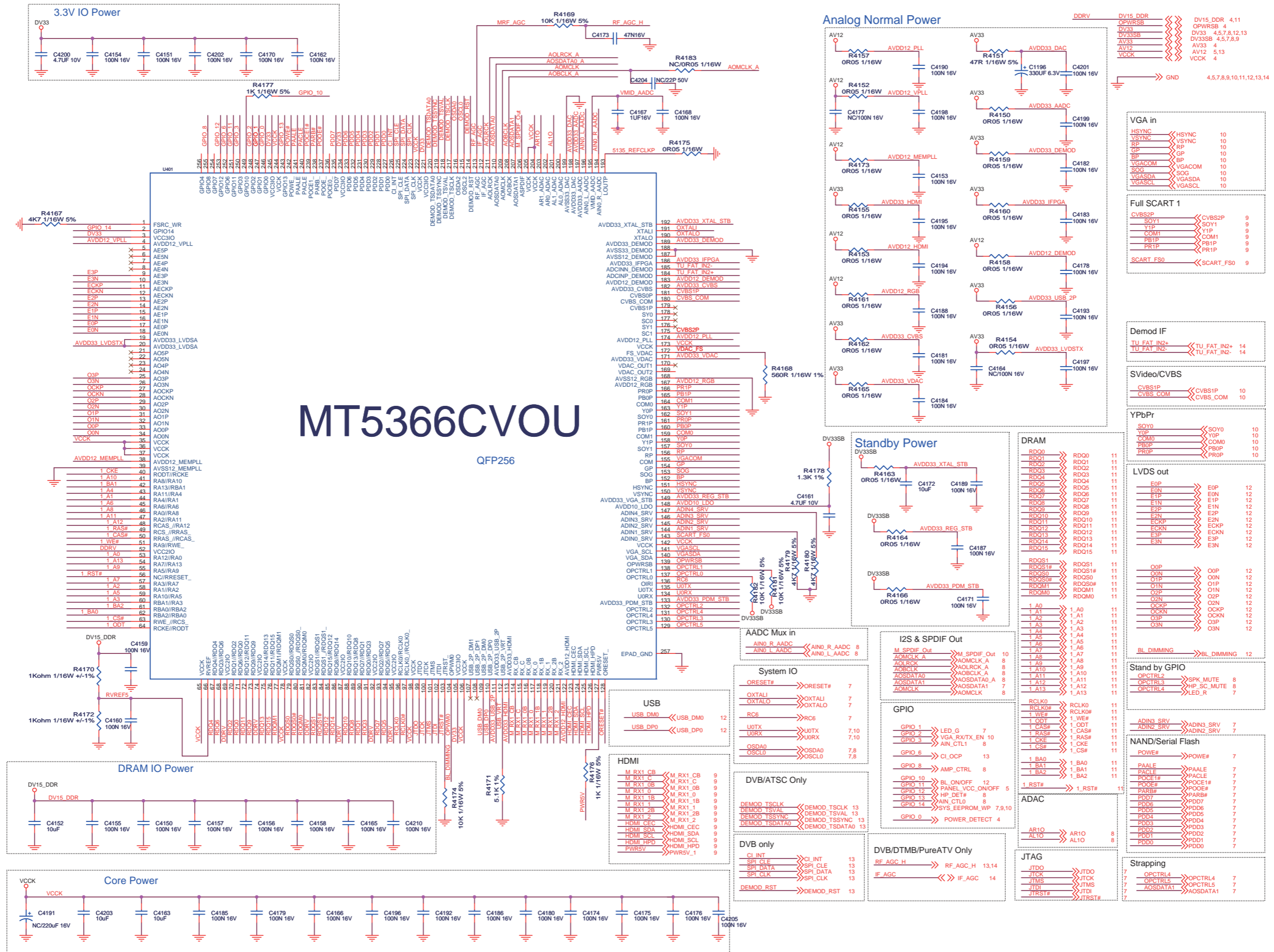

# MT5366CVOU

QFP256

MT5366 cvou 715G4796

FLASH/UART/IR/JTAG

B04

FLASH/UART/IR/JTAG

B04

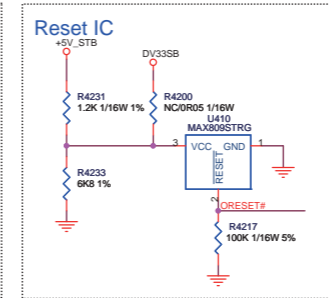
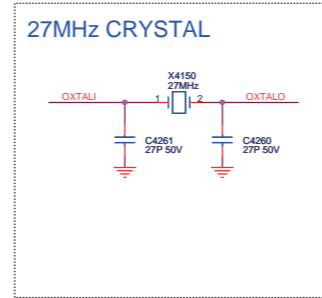
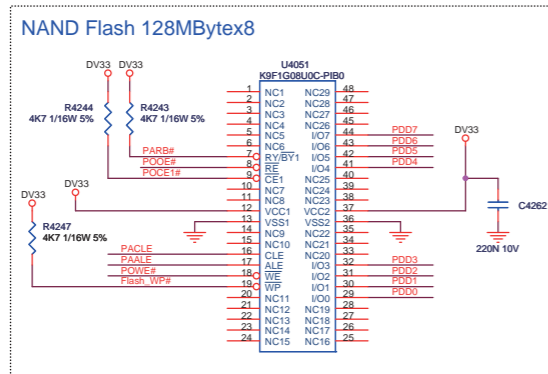

+5V_SW	+5V_SW	4.5,5.8,9,10,12,13
+5V_STB	+5V_STB	4.5
DV33	DV33	4.5,6.8,12,13
DV33SB	DV33SB	4.5,6.8,9
GND	GND	4.5,6.8,9,10,11,12,13,14

FLASH		
POWE#	POWE#	6
PAALE	PAALE	6
POCLE	POCLE	6
POCE#	POCE#	6
PODE#	PODE#	6
PARB#	PARB#	6
PDD7	PDD7	6
PDD6	PDD6	6
PDD5	PDD5	6
PDD4	PDD4	6
PDD3	PDD3	6
PDD2	PDD2	6
PDD1	PDD1	6
PDD0	PDD0	6

JTAG		
JTDO	JTDO	6
JTCK	JTCK	6
JTMS	JTMS	6
JTDI	JTDI	6
JTRST#	JTRST#	6

XTAL & RESET		
OXTALI	OXTALI	6
OXTALO	OXTALO	6
ORESET#	ORESET#	6

SYS EEPROM		
OSDA0	OSDA0	6,8
OSCL0	OSCL0	6,8
SYS_EEPROM_WP	SYS_EEPROM_WP	6,9,10

U-ART & RS232		
U0TX	U0TX	6,10
U0RX	U0RX	6,10

IR & KEY		
ADIN2_SRV	ADIN2_SRV	6
ADIN3_SRV	ADIN3_SRV	6
RCS	RCS	6
LED_G	LED_G	6
LED_R	LED_R	6

STRAPPING		
OPCTRL4	OPCTRL4	6
OPCTRL5	OPCTRL5	6
AOSDATA1	AOSDATA1	6

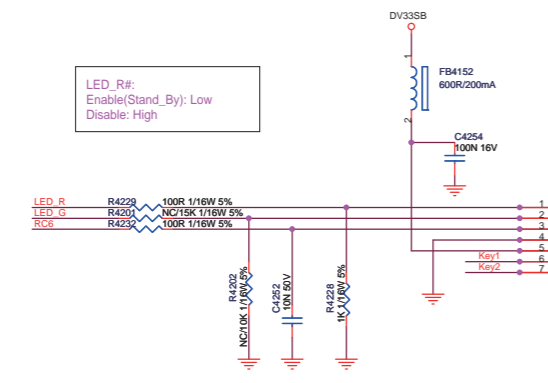
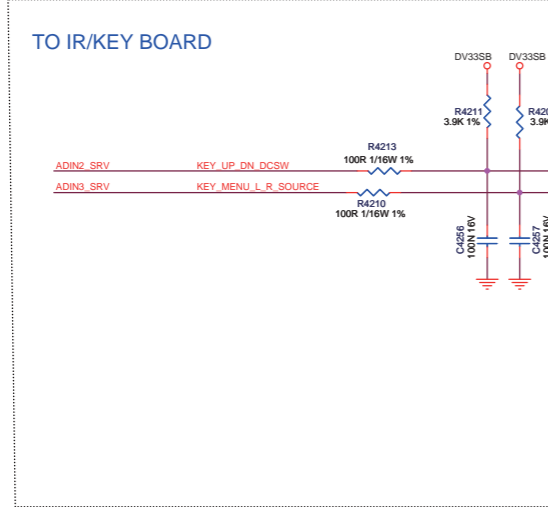
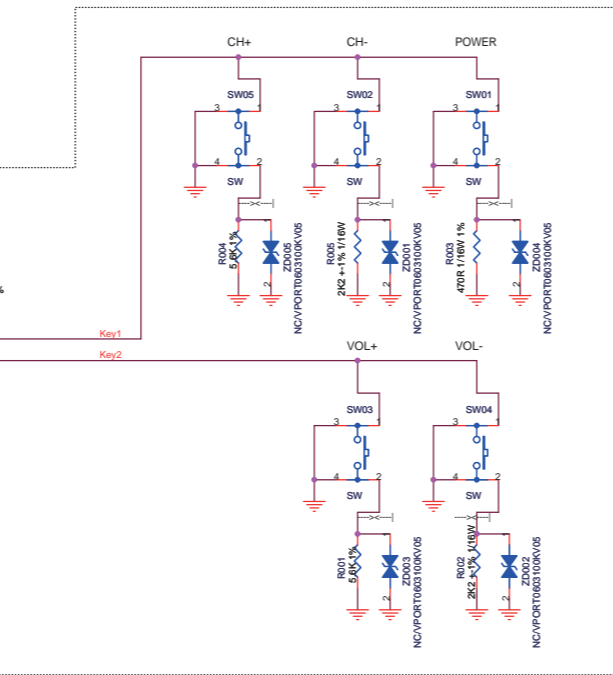
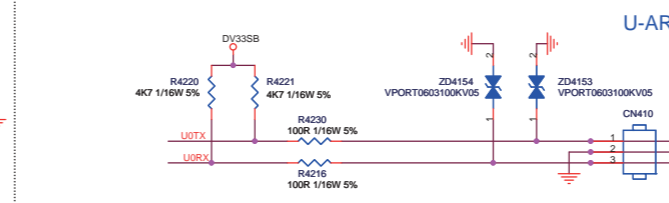
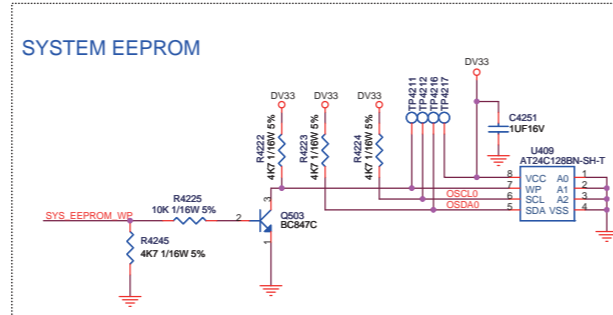
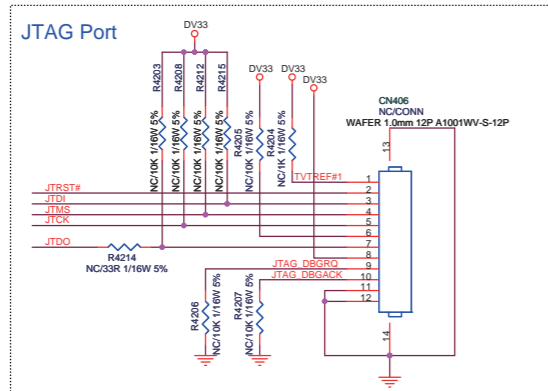

FLASH/UART/IR/JTAG	715G4796	1	2011-05-17



SPK AMP / HP AMP / AUD MUX

B05

SPK AMP / HP AMP / AUD MUX

B05

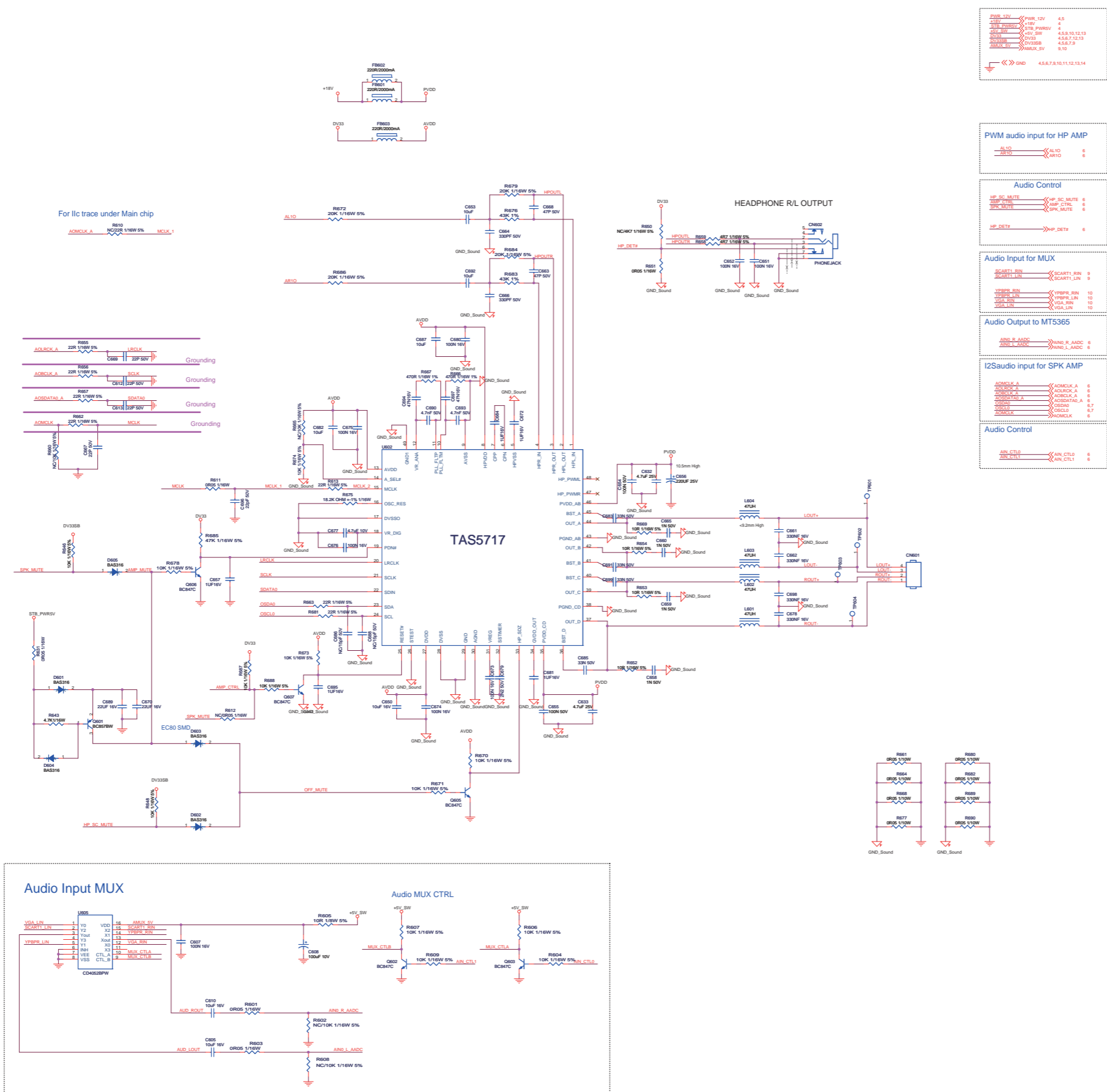

FB02	220µF	18V	4.5
FB03	220µF	18V	4
FB04	220µF	18V	4
FB05	220µF	18V	4
FB06	220µF	18V	4
FB07	220µF	18V	4
FB08	220µF	18V	4
FB09	220µF	18V	4
FB10	220µF	18V	4
FB11	220µF	18V	4
FB12	220µF	18V	4
FB13	220µF	18V	4
FB14	220µF	18V	4
FB15	220µF	18V	4
FB16	220µF	18V	4
FB17	220µF	18V	4
FB18	220µF	18V	4
FB19	220µF	18V	4
FB20	220µF	18V	4
FB21	220µF	18V	4
FB22	220µF	18V	4
FB23	220µF	18V	4
FB24	220µF	18V	4
FB25	220µF	18V	4
FB26	220µF	18V	4
FB27	220µF	18V	4
FB28	220µF	18V	4
FB29	220µF	18V	4
FB30	220µF	18V	4
FB31	220µF	18V	4
FB32	220µF	18V	4
FB33	220µF	18V	4
FB34	220µF	18V	4
FB35	220µF	18V	4
FB36	220µF	18V	4
FB37	220µF	18V	4
FB38	220µF	18V	4
FB39	220µF	18V	4
FB40	220µF	18V	4
FB41	220µF	18V	4
FB42	220µF	18V	4
FB43	220µF	18V	4
FB44	220µF	18V	4
FB45	220µF	18V	4
FB46	220µF	18V	4
FB47	220µF	18V	4
FB48	220µF	18V	4
FB49	220µF	18V	4
FB50	220µF	18V	4
FB51	220µF	18V	4
FB52	220µF	18V	4
FB53	220µF	18V	4
FB54	220µF	18V	4
FB55	220µF	18V	4
FB56	220µF	18V	4
FB57	220µF	18V	4
FB58	220µF	18V	4
FB59	220µF	18V	4
FB60	220µF	18V	4
FB61	220µF	18V	4
FB62	220µF	18V	4
FB63	220µF	18V	4
FB64	220µF	18V	4
FB65	220µF	18V	4
FB66	220µF	18V	4
FB67	220µF	18V	4
FB68	220µF	18V	4
FB69	220µF	18V	4
FB70	220µF	18V	4
FB71	220µF	18V	4
FB72	220µF	18V	4
FB73	220µF	18V	4
FB74	220µF	18V	4
FB75	220µF	18V	4
FB76	220µF	18V	4
FB77	220µF	18V	4
FB78	220µF	18V	4
FB79	220µF	18V	4
FB80	220µF	18V	4
FB81	220µF	18V	4
FB82	220µF	18V	4
FB83	220µF	18V	4
FB84	220µF	18V	4
FB85	220µF	18V	4
FB86	220µF	18V	4
FB87	220µF	18V	4
FB88	220µF	18V	4
FB89	220µF	18V	4
FB90	220µF	18V	4
FB91	220µF	18V	4
FB92	220µF	18V	4
FB93	220µF	18V	4
FB94	220µF	18V	4
FB95	220µF	18V	4
FB96	220µF	18V	4
FB97	220µF	18V	4
FB98	220µF	18V	4
FB99	220µF	18V	4
FB100	220µF	18V	4

PWM audio input for HP AMP

ALIO	ALIO	6
ALIO	ALIO	6

Audio Control

HP_SC_MUTE	HP_SC_MUTE	6
HP_MUTE	HP_MUTE	6
HP_MUTE	HP_MUTE	6
HP_DET	HP_DET	6

Audio input for MUX

SCART1_RIN	SCART1_RIN	9
SCART1_LIN	SCART1_LIN	9
YPSP_RIN	YPSP_RIN	10
YPSP_LIN	YPSP_LIN	10
YGA_RIN	YGA_RIN	10
YGA_LIN	YGA_LIN	10

Audio Output to MTS365

AND_R_AADC	AND_R_AADC	6
AND_L_AADC	AND_L_AADC	6

I2SAudio input for SPK AMP

AMCLK_A	AMCLK_A	6
AMCLK_B	AMCLK_B	6
AMCLK_C	AMCLK_C	6
AMCLK_D	AMCLK_D	6
AMCLK_E	AMCLK_E	6
AMCLK_F	AMCLK_F	6
AMCLK_G	AMCLK_G	6
AMCLK_H	AMCLK_H	6
AMCLK_I	AMCLK_I	6
AMCLK_J	AMCLK_J	6

Audio Control

AN_CTL0	AN_CTL0	6
AN_CTL1	AN_CTL1	6

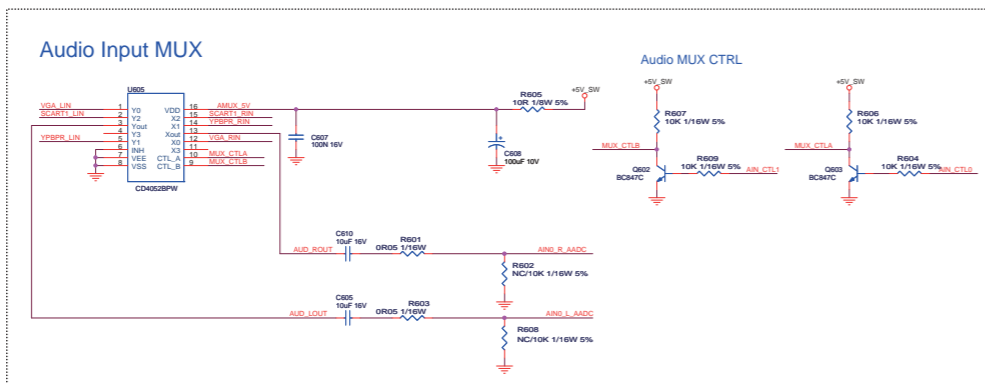

SPK AMP / HP AMP / AUD MUX	715G4796	1	2011-05-17

SCART I/O / HDMI1 INPUT

B06

SCART I/O / HDMI1 INPUT

B06

SCART(RGB + CVBS)

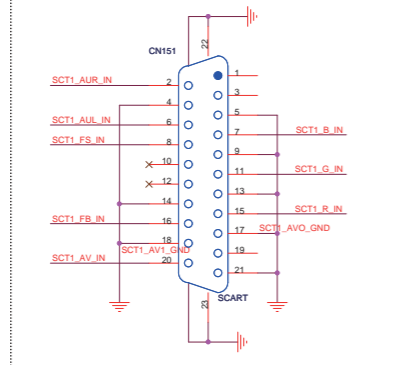

Function Select

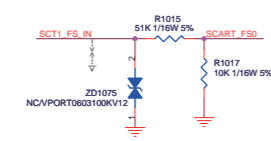

CVBS IN

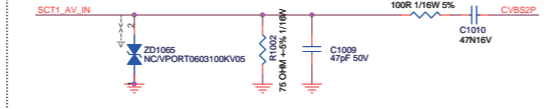

RGB IN

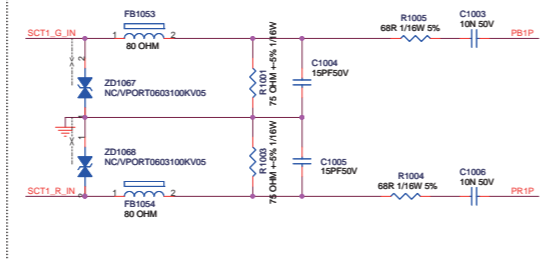
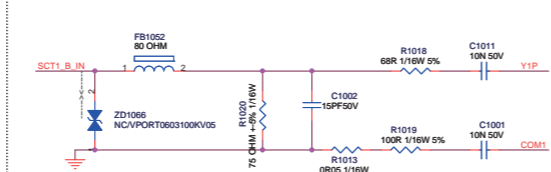

SCART Audio Input

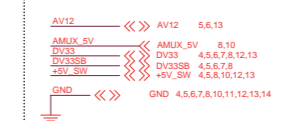
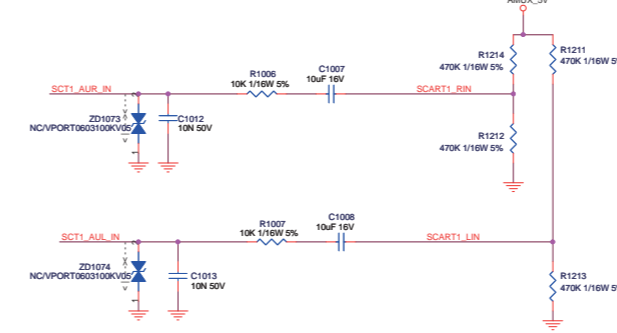

SCART1 in\_out

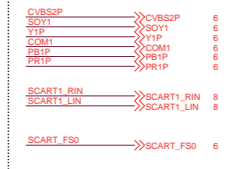

HDMI output to MTS365

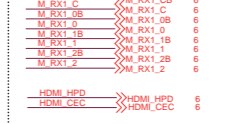

HDMI I2C

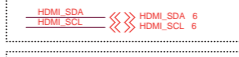

HDMI control

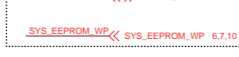

FAST BLANKING/SOY

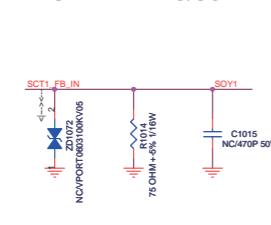

Rear HDMI 1

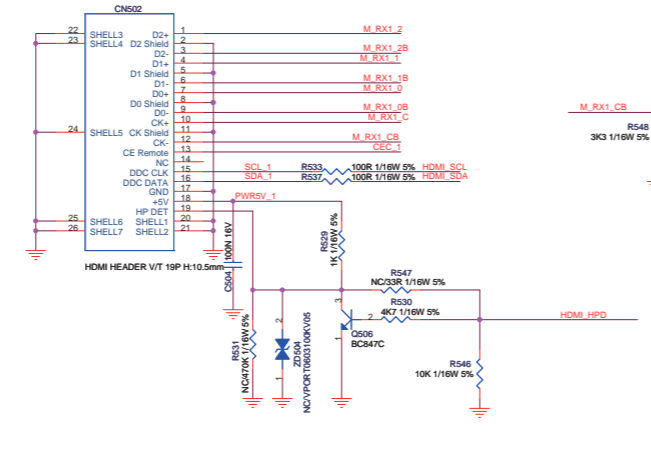

HDMI1 ESD PROTECTOR

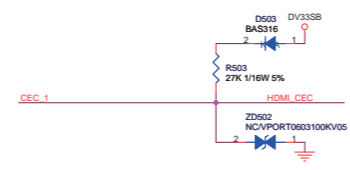
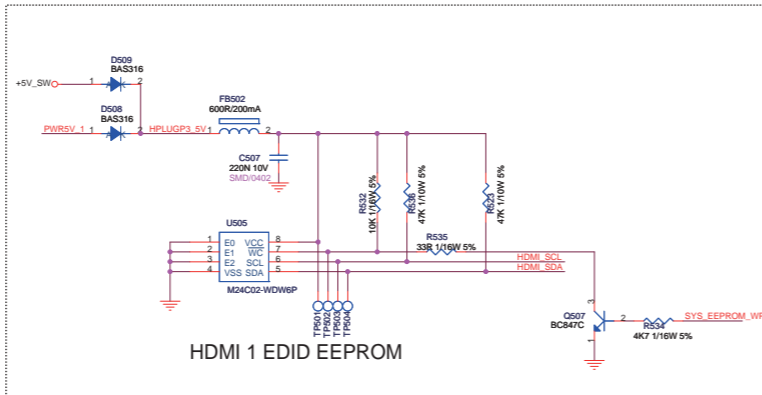
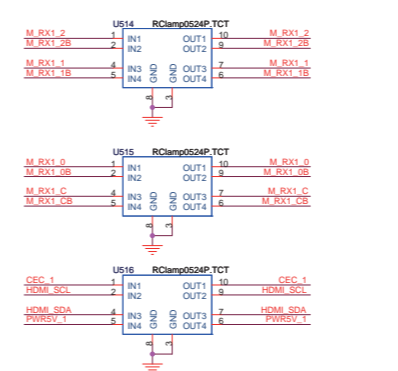

SCART I/O / HDMI1 INPUT	715G4796	1	2011-05-17

YPBPR/ VGA INPUT

B07

YPBPR/ VGA INPUT

B07

YPbPr in SPDIF output

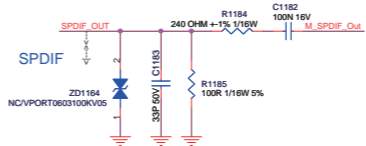
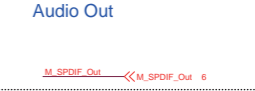
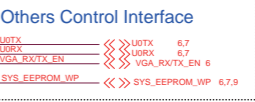
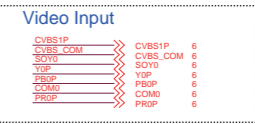
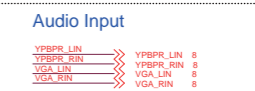
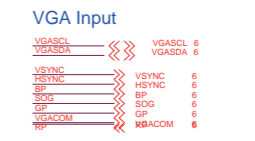
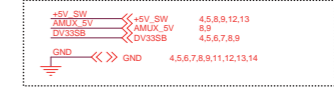
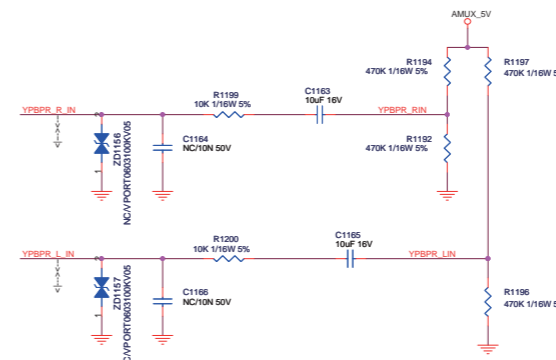
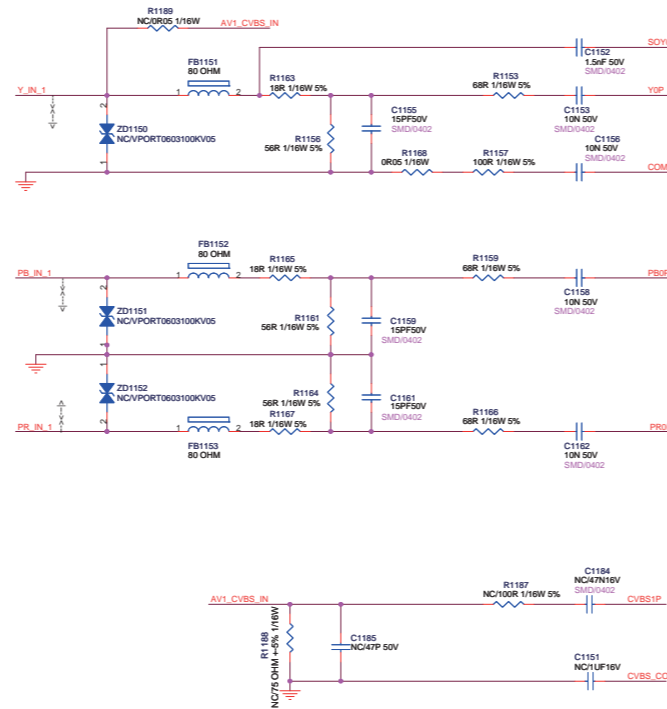
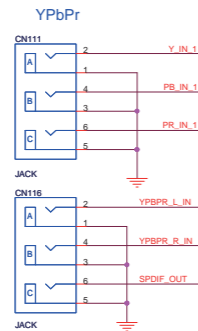

VGA & Audio in

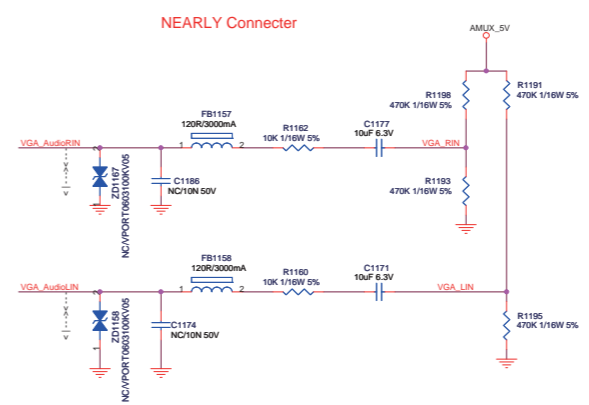
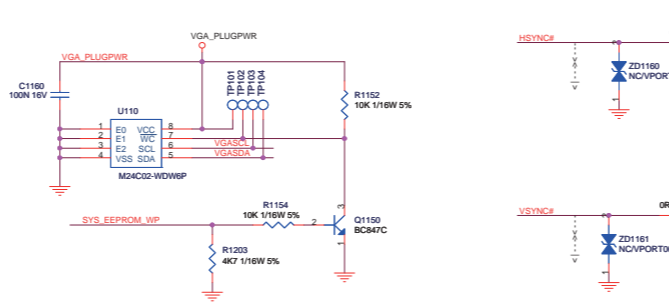
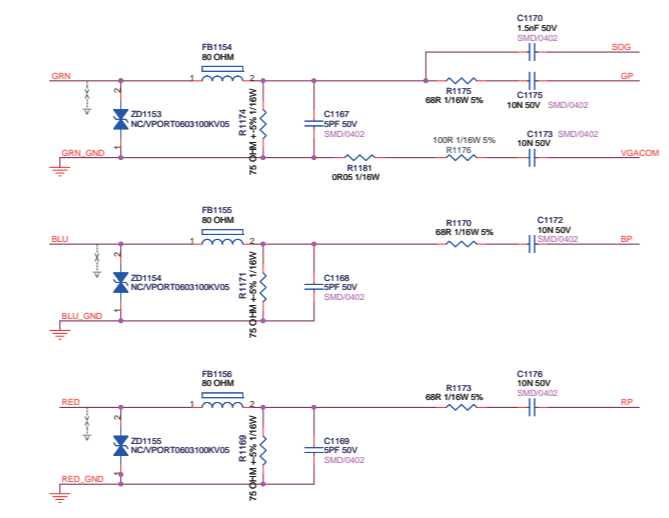
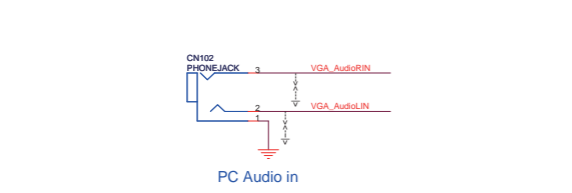
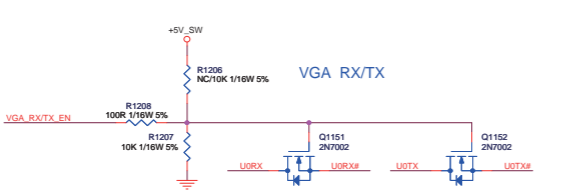
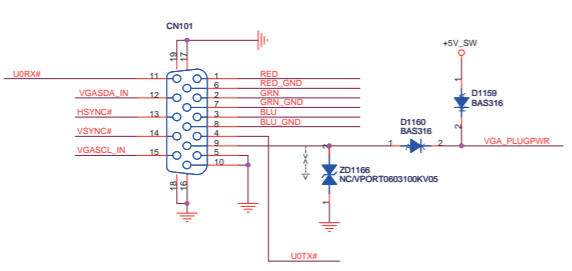

YPBPR/ VGA INPUT	715G4796	1	2011-09-17

DDR3 DRAM

**B08**

DDR3 DRAM

**B08**

**DDR3#1** U404 **DDR3 64Mx16Bits /1.3GHz**

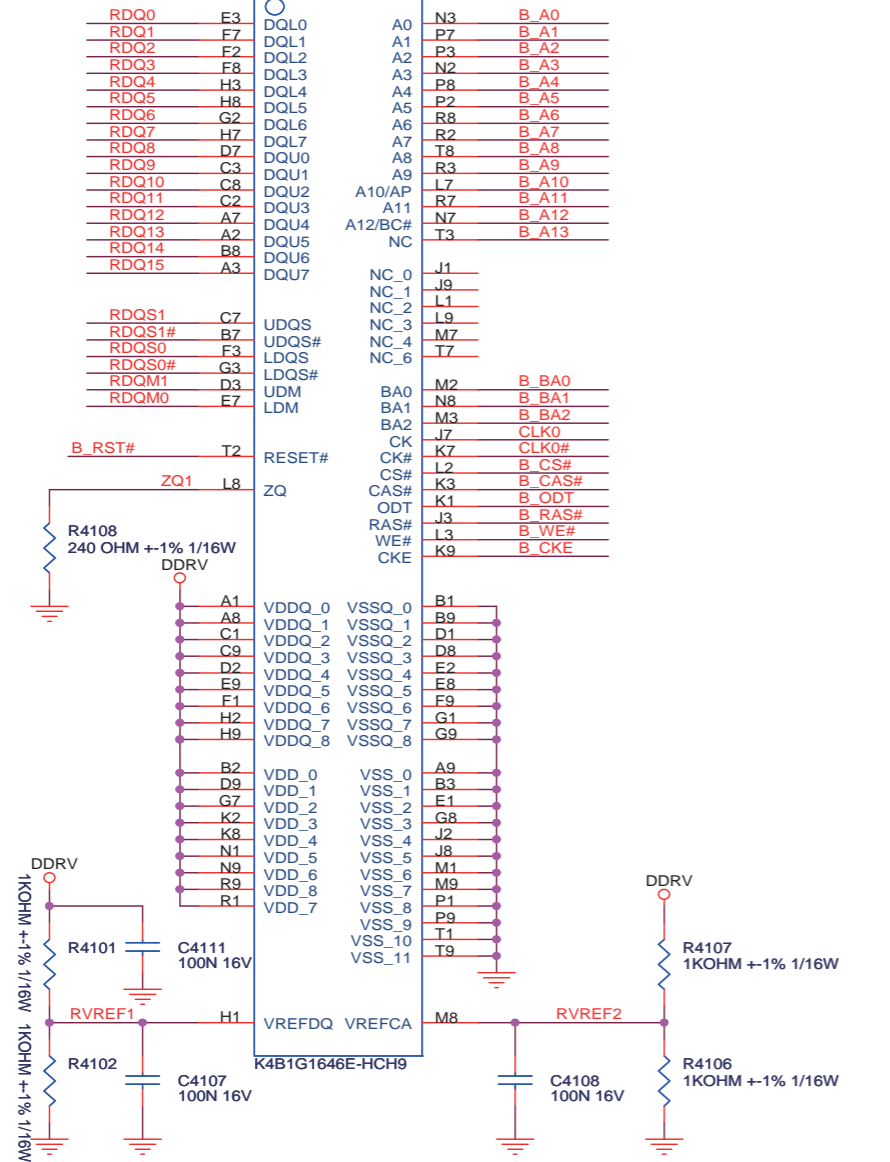

Damping and Termination for CLK

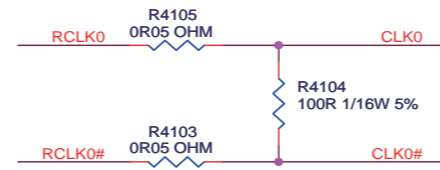

Damping for DDR#1 ADDR/CMD

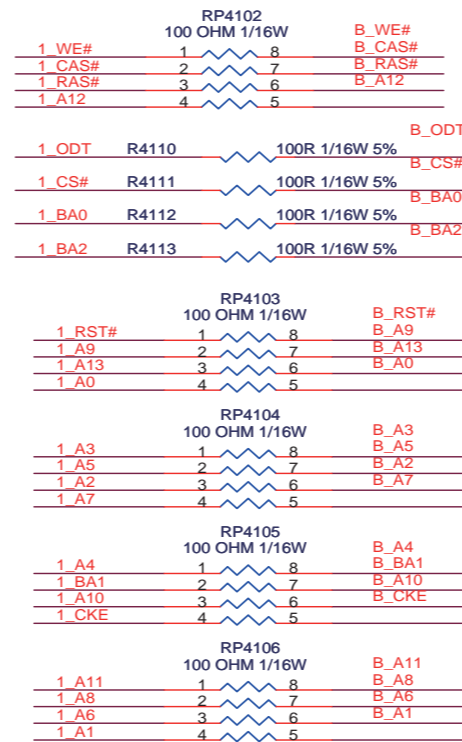

DDR interface from MT5365

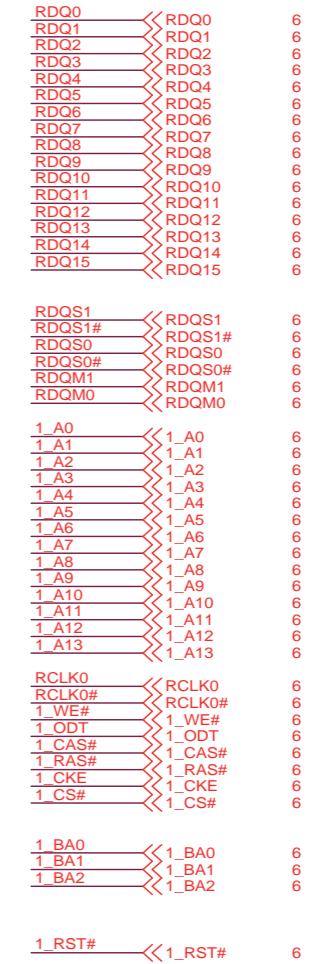

CAPs for DRAM IO Power ( Close to DDR#1 )

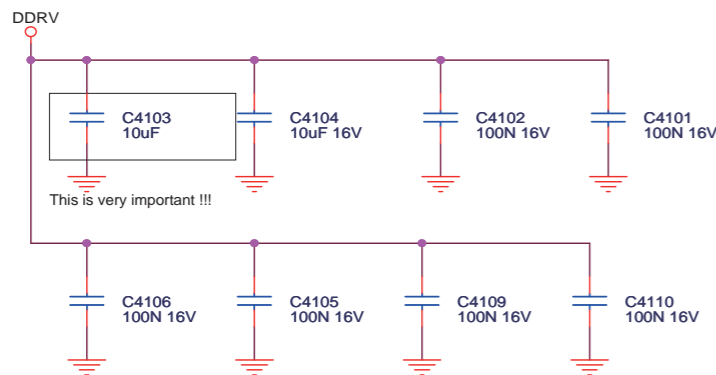

DDR3 DRAM	715G4796	1	2011-05-17

LVDS OUTPUT/USB

B09

LVDS OUTPUT/USB

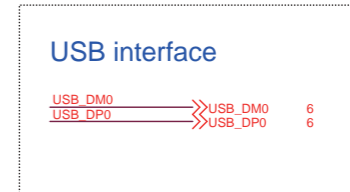
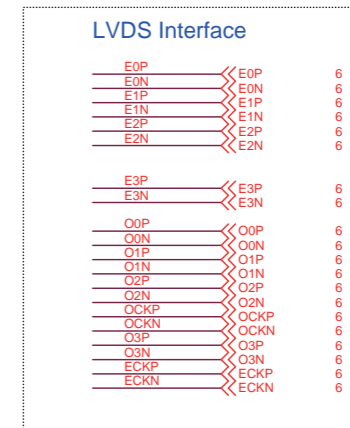
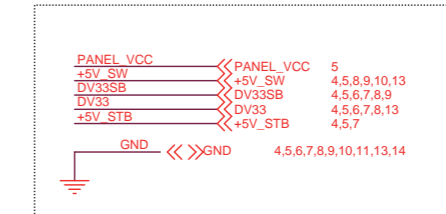
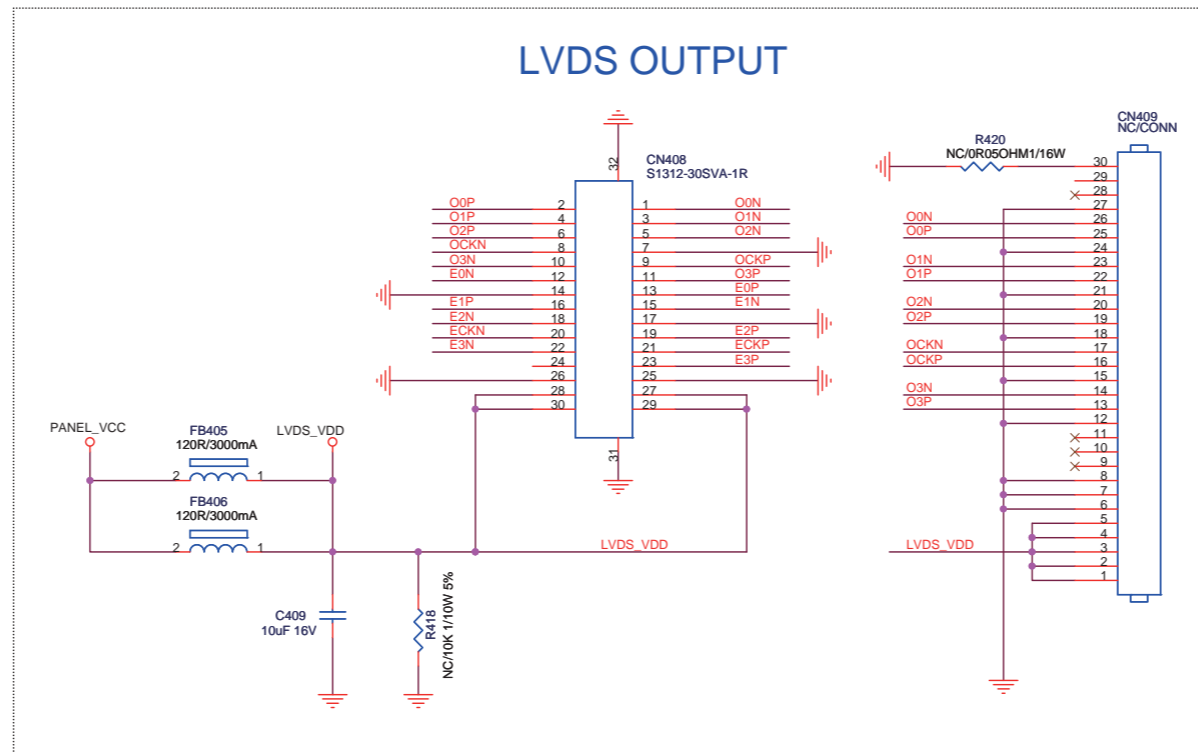
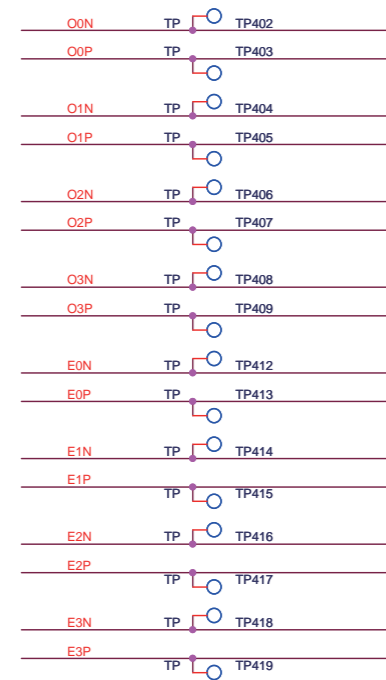

Backlight Brightness Control

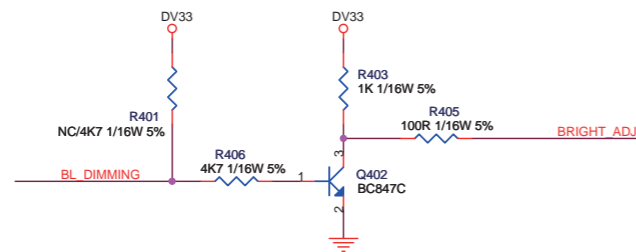

Backlight ON/OFF Control

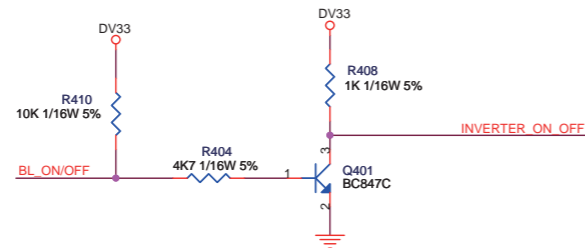

USB 2.0

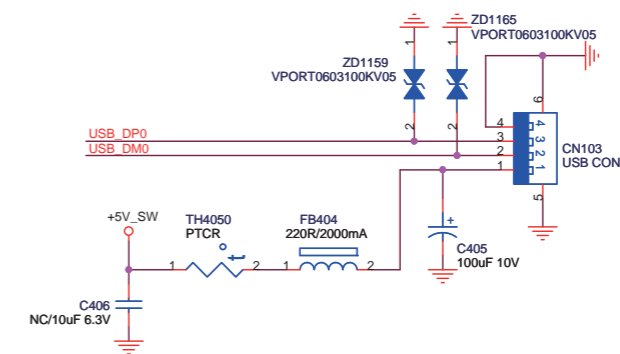

LVDS OUTPUT/USB	715G4796	1	2011-05-17

B10

DVB-T+C\_DEMOD MT5135 / CI

B10

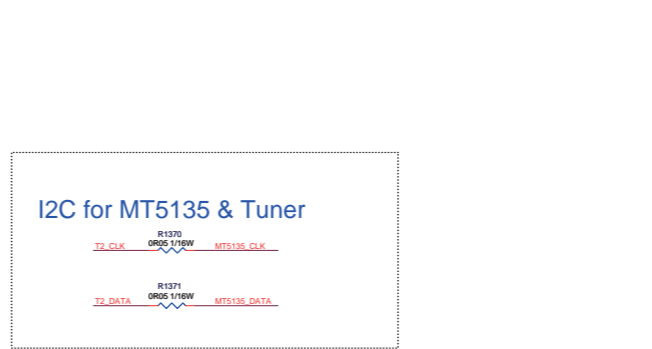
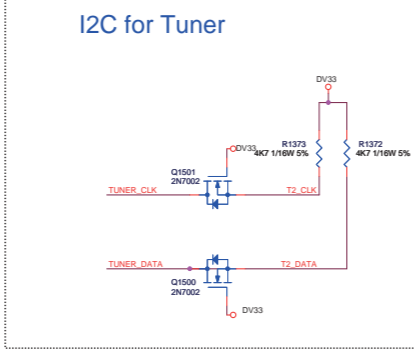
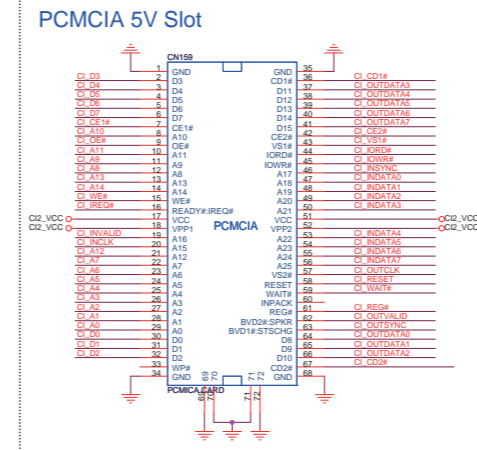
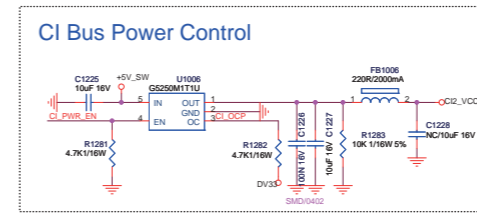
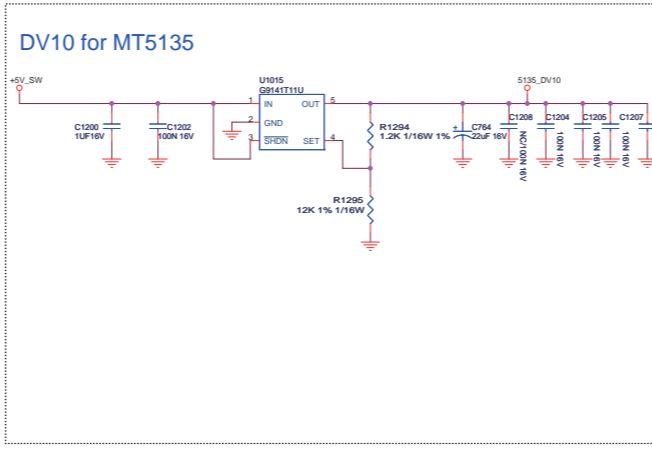
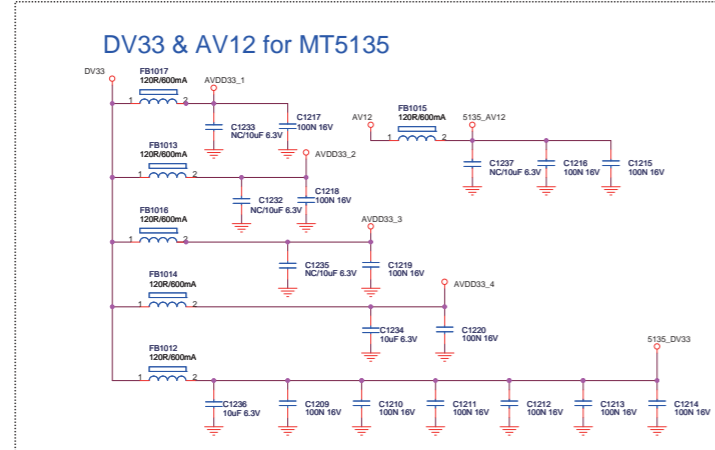
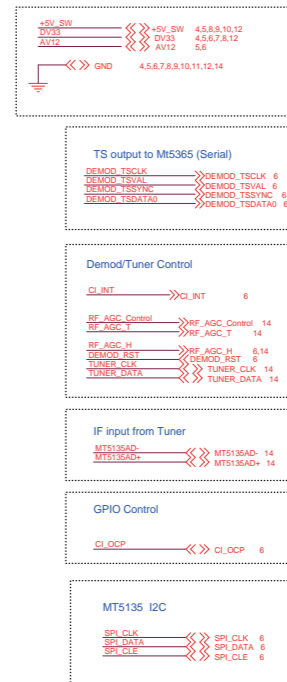
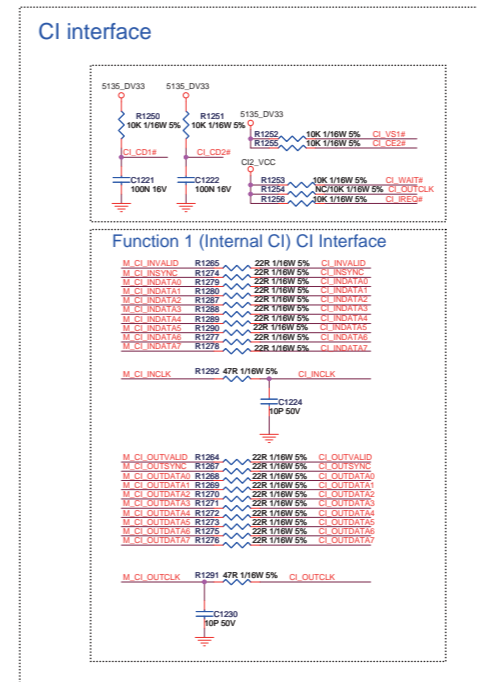
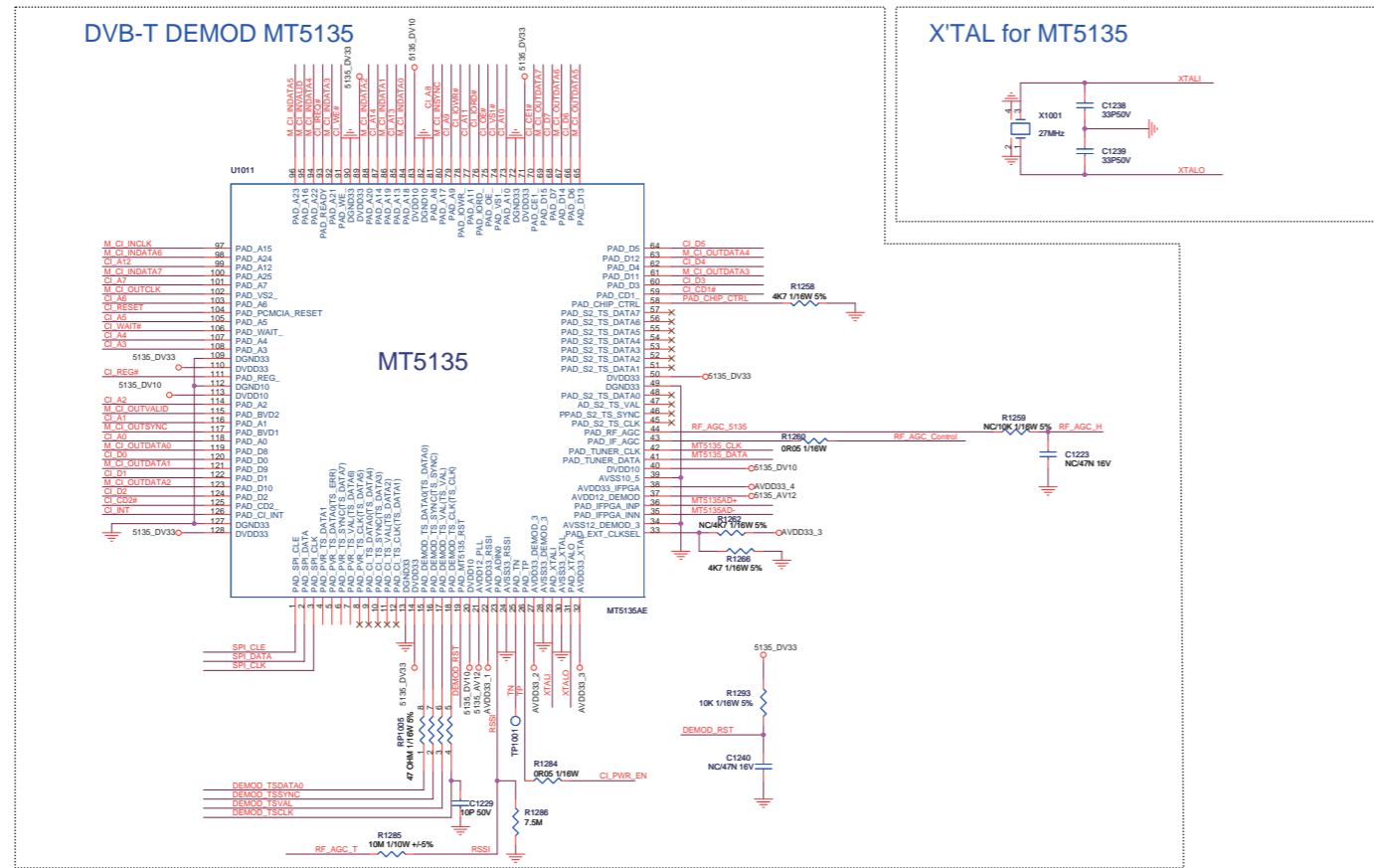

DVB-T+C_DEMOD MT5135 / CI	715G4796	1	2011-05-17



DVB-T+C\_TUNER

B11

DVB-T+C\_TUNER

B11

+5V for Tuner

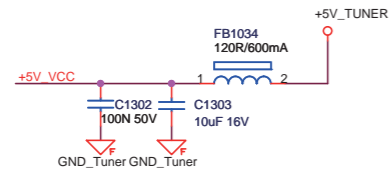

I2C for Tuner and MT5135

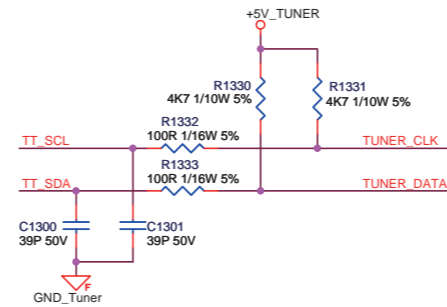

Tuner IF output



Tuner Control

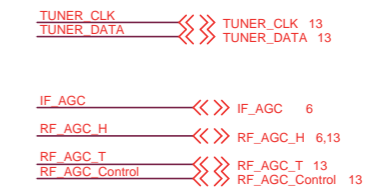

TUNER

LG Tuner with DVB-C/T:G731D(sawless)

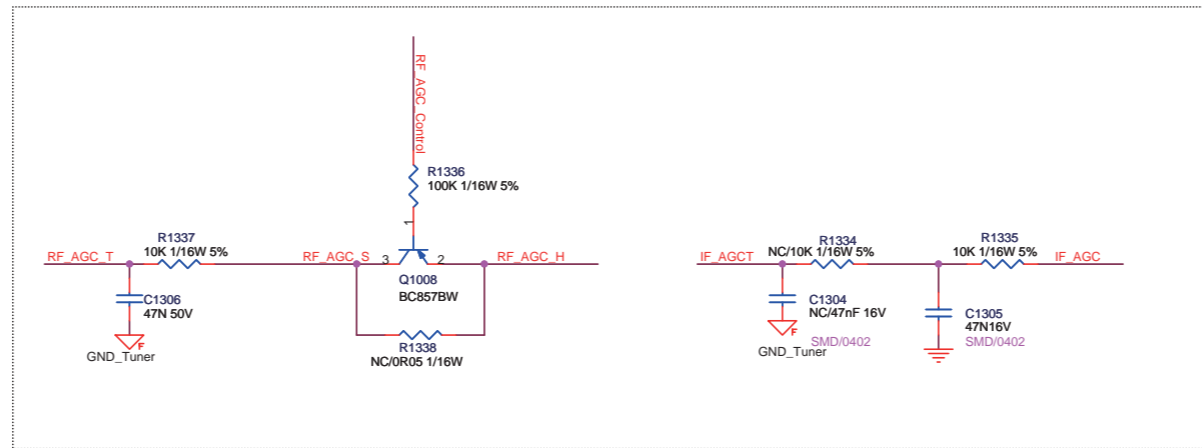
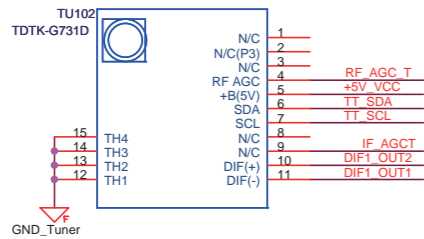

BPF

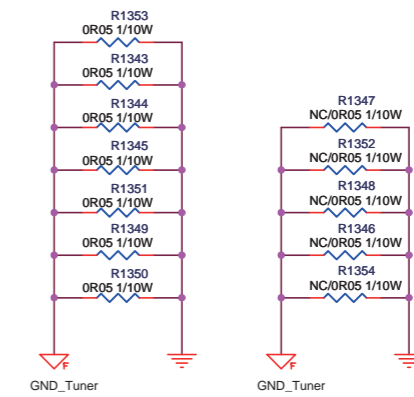
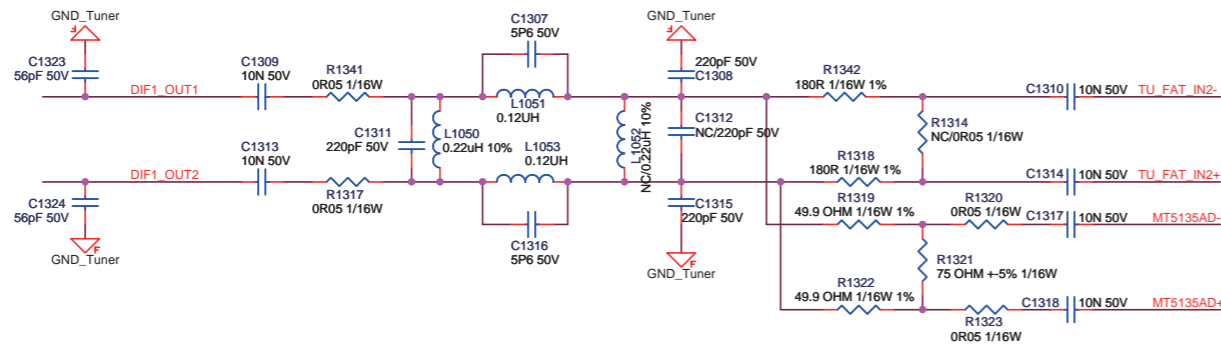

DVB-T+C_TUNER	715G4796	1	2011-05-17

SSB layout top

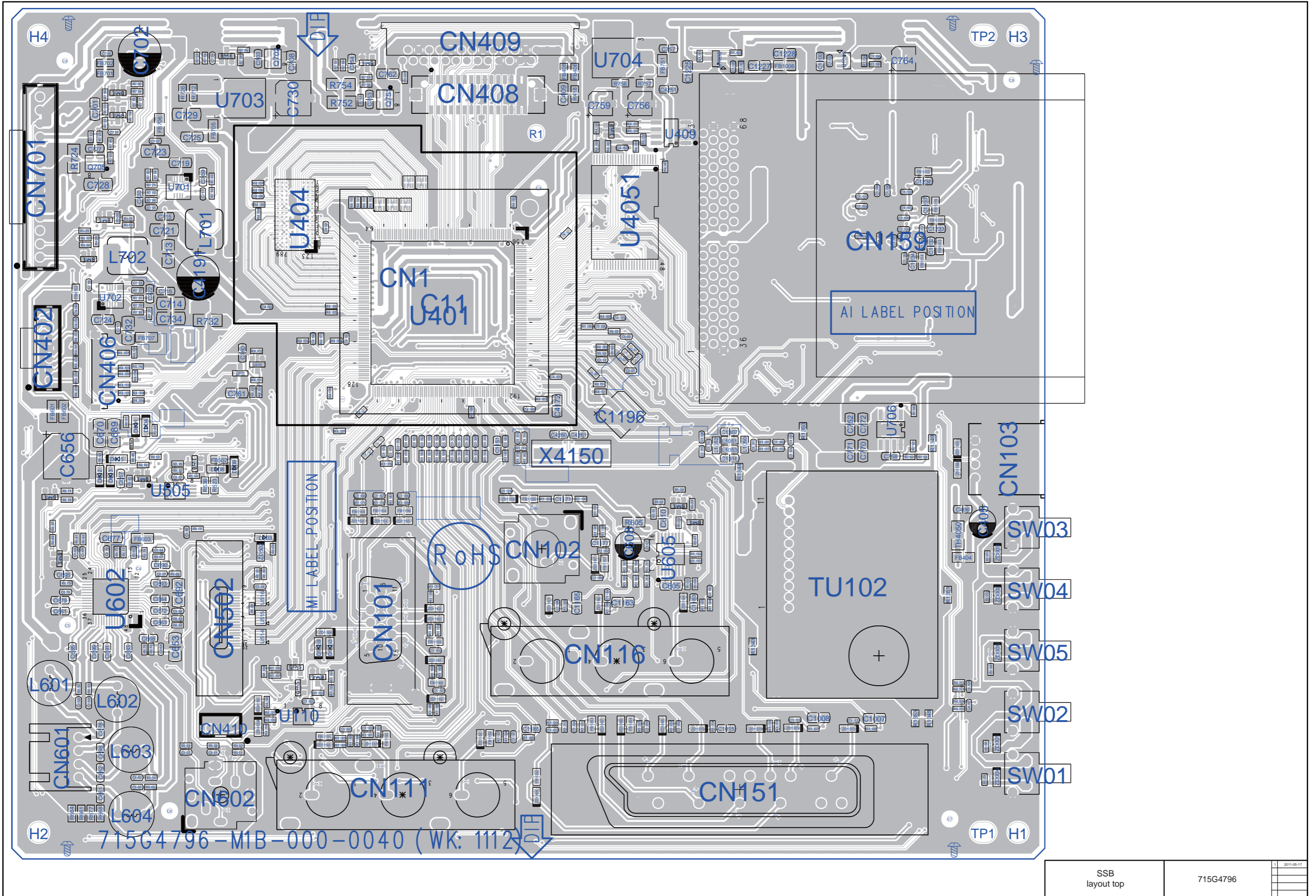

SSB layout top	715G4796	110519

SSB layout bottom

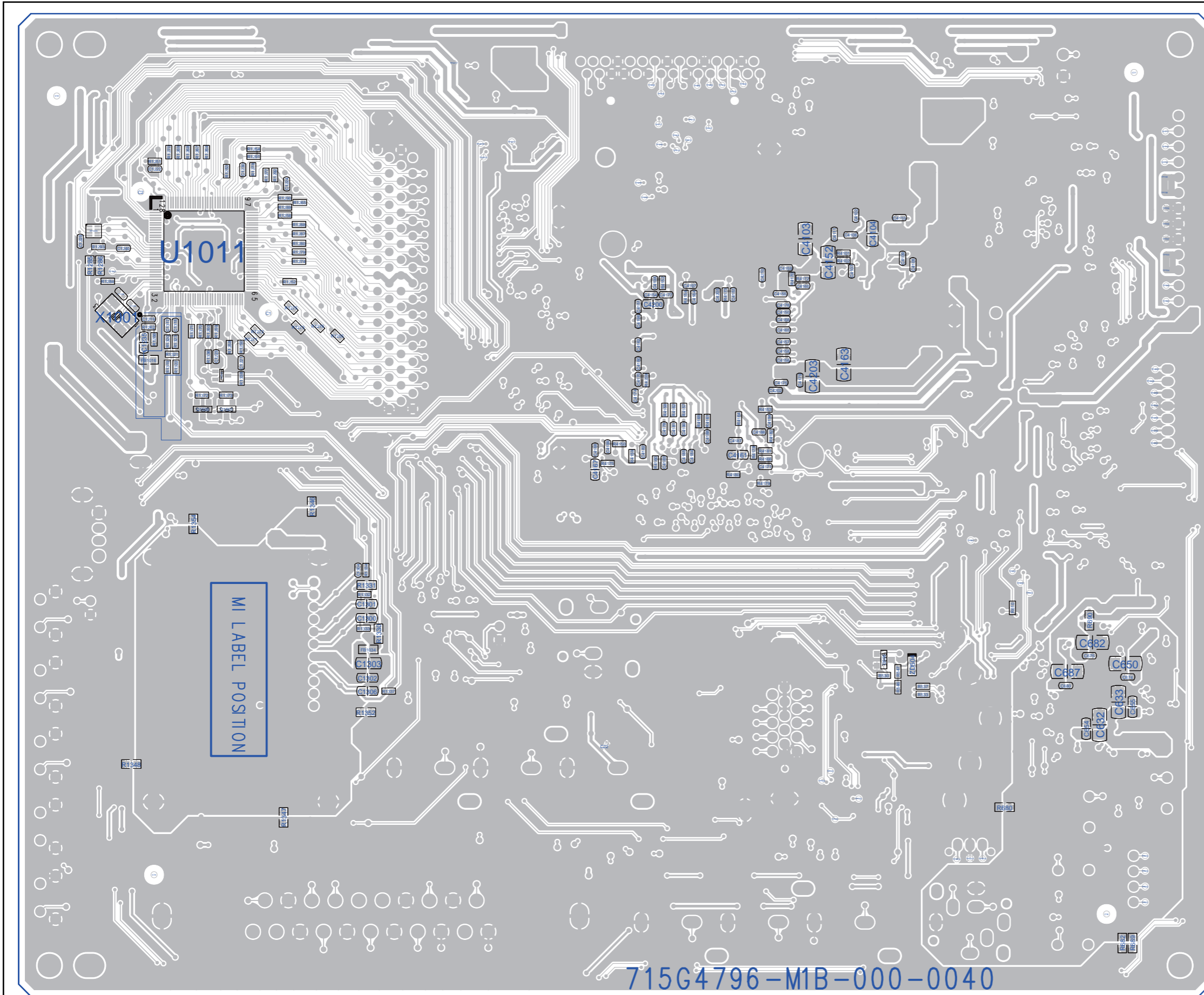

SSB layout bottom	715G4796	1	2011-06-17

10-6 J 715G4939 IR Golden horse  
IR/LED board

J

IR/LED

J

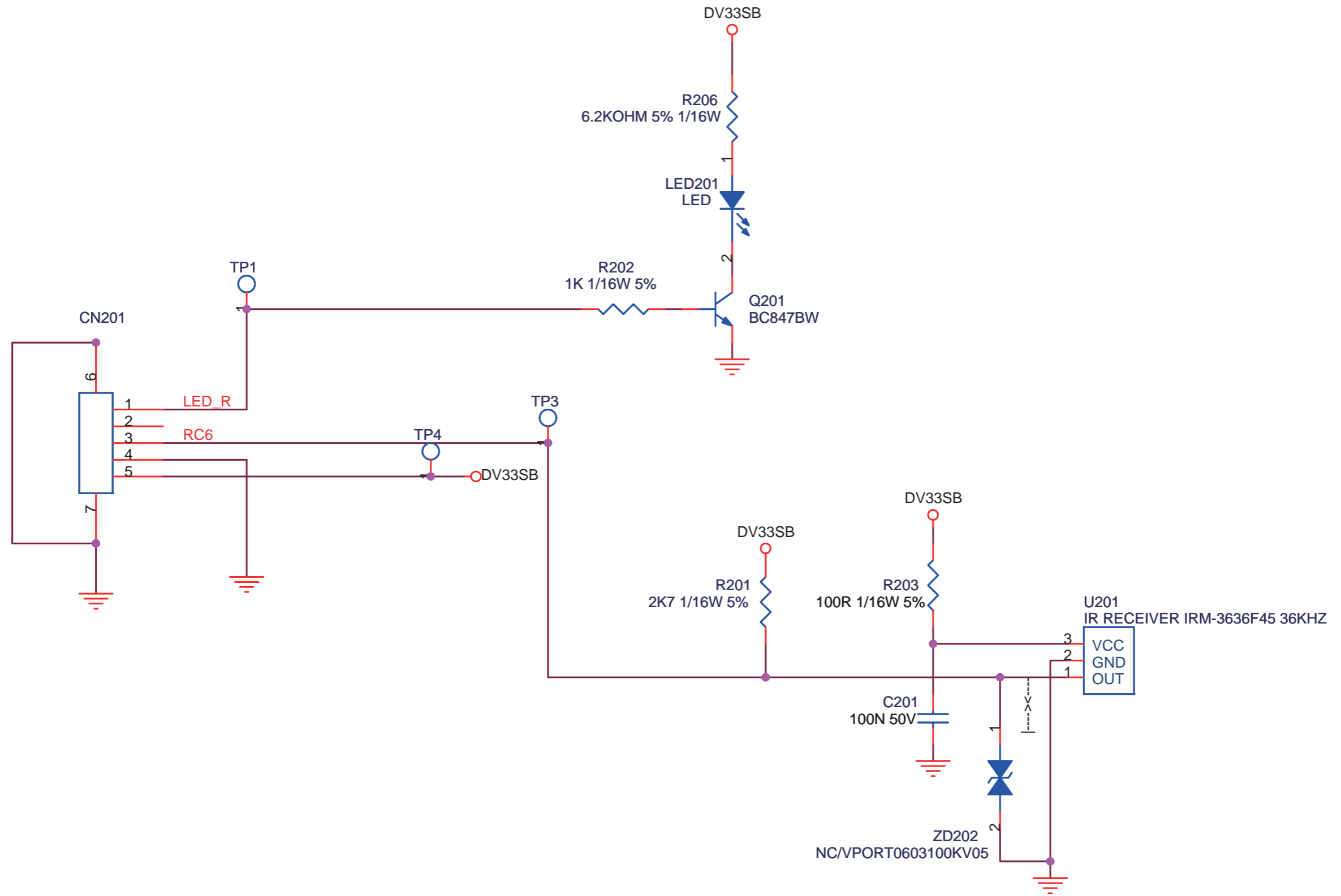

IR/LED Board	715G4939	1	2011-04-19

IR/LED board layout

Layout IR/LED Board (Top Side)

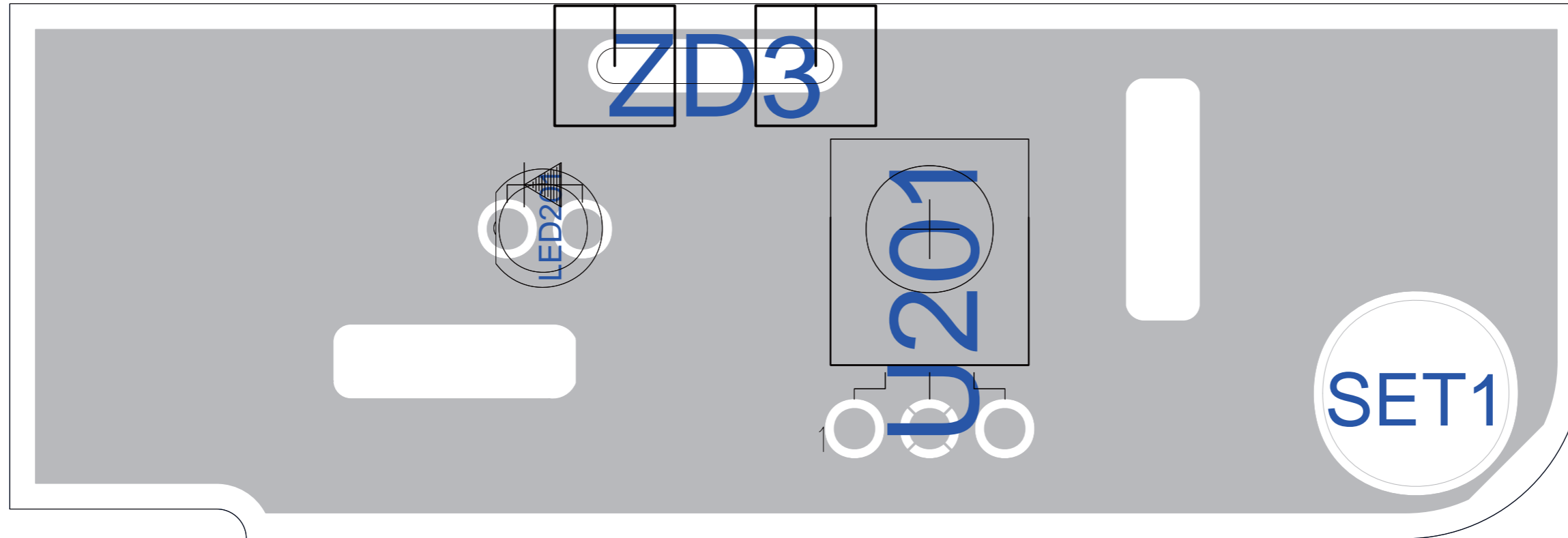

Layout IR/LED Board (Bottom Side)

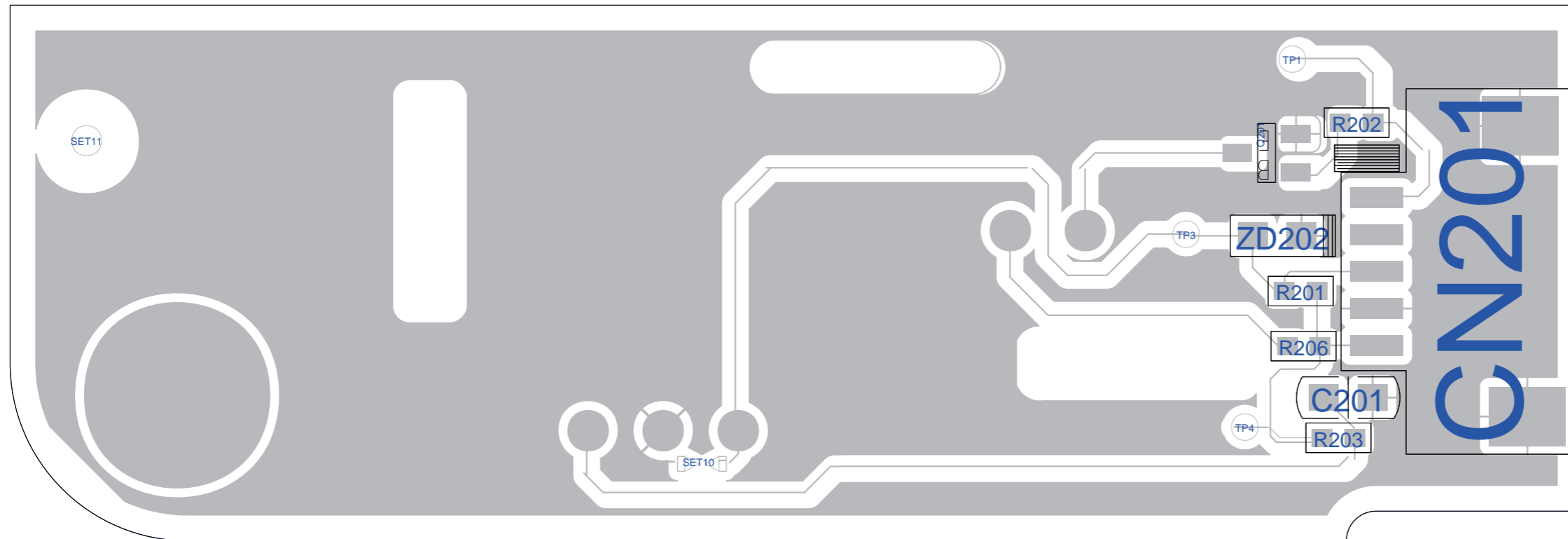

IR/LED board layout top/bottom	715G4939	2011-04-18

10-7 J 715G5219 IR Spot Deal 22"  
IR/LED board

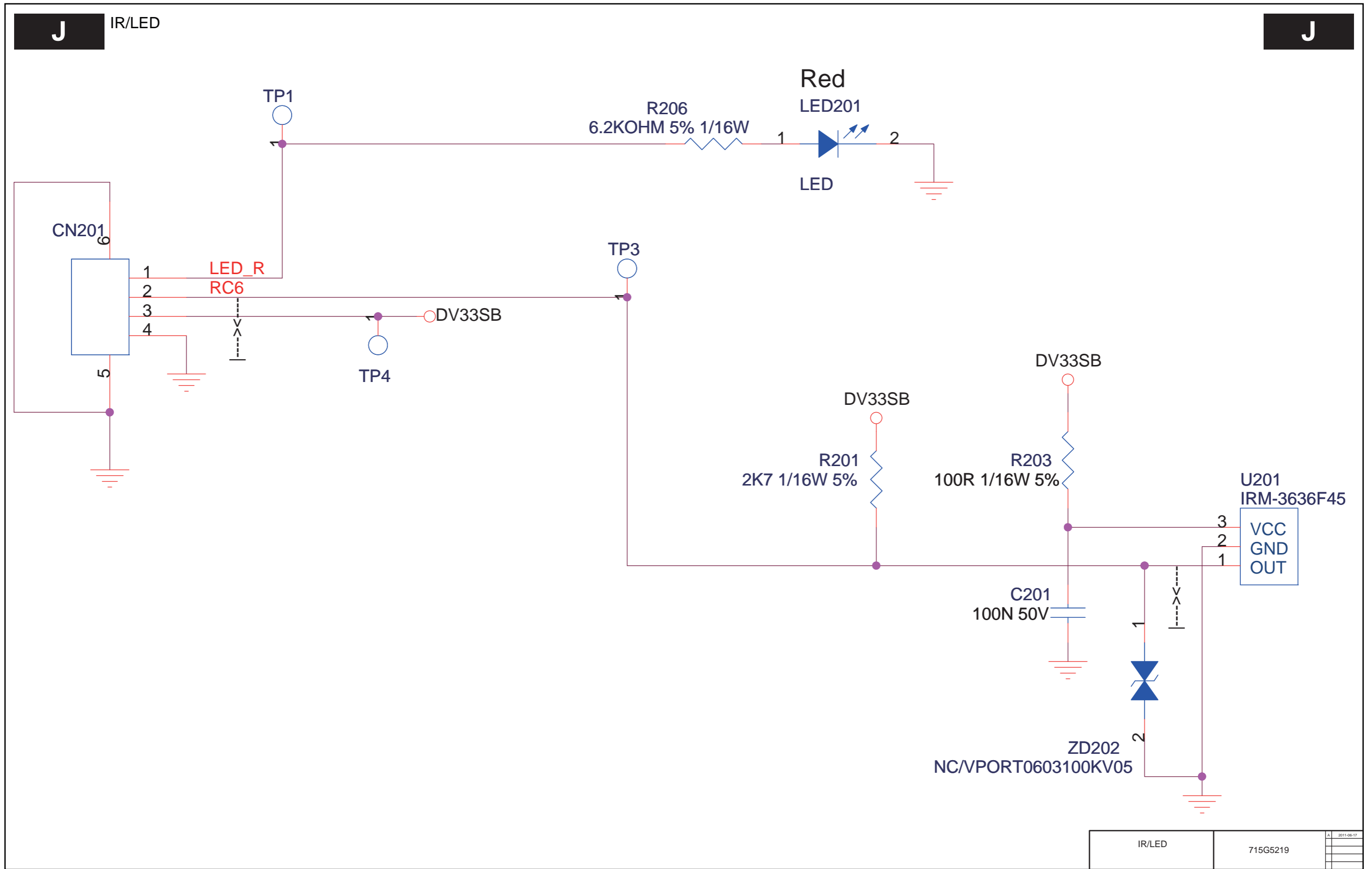

IR/LED	715G5219	A	2011-06-17



IR/LED board layout

Layout IR/LED Board (Top Side)

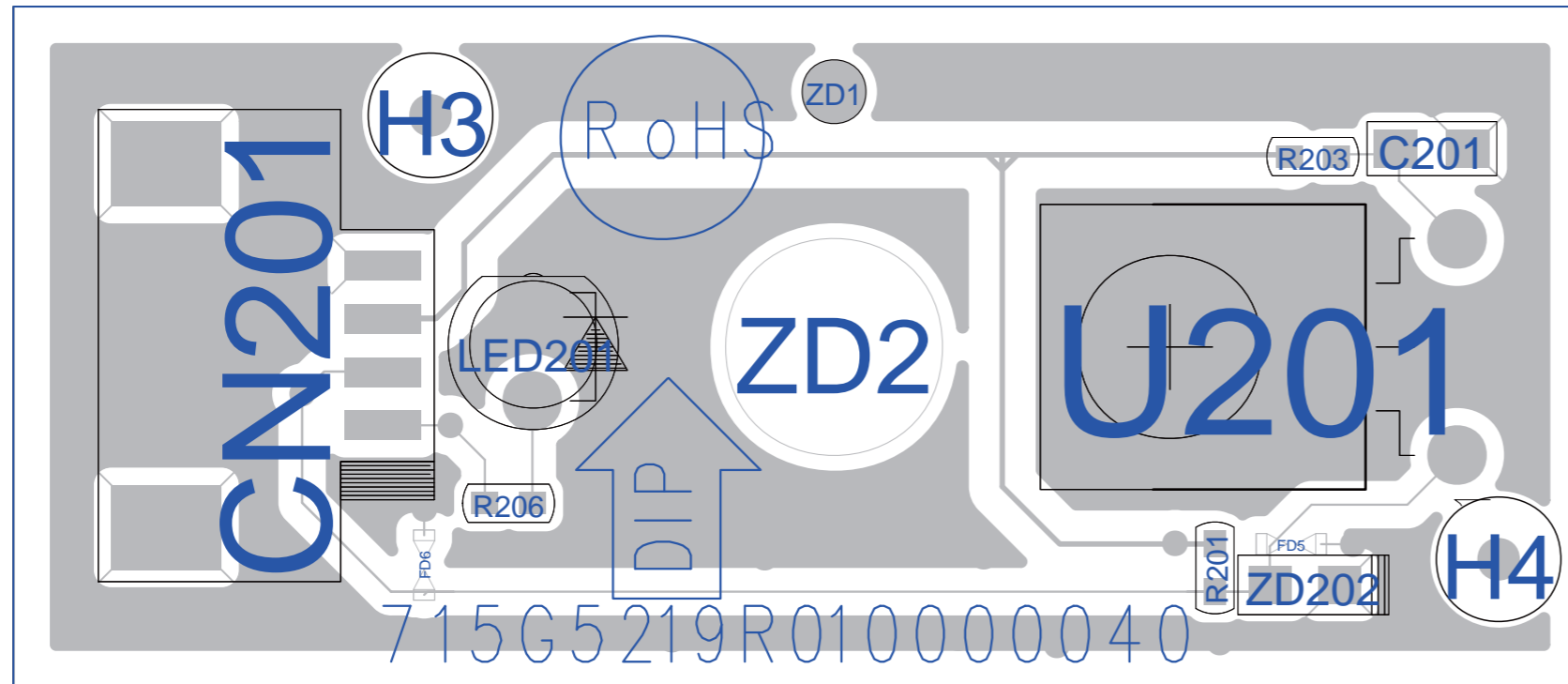

Layout IR/LED Board (Bottom Side)

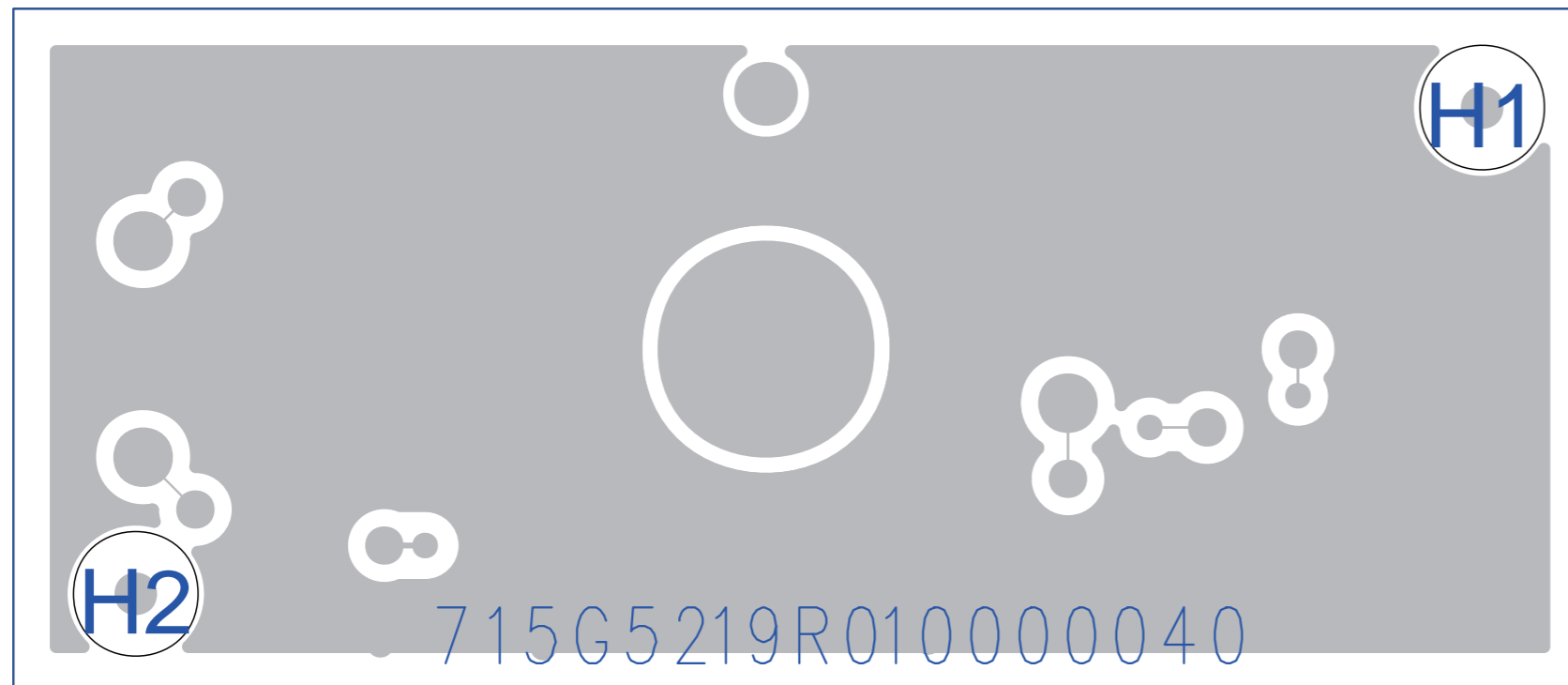

IR/LED board layout top/bottom	715G5219	A	2011-06-17

10-8 J 715G5217 IR Spot Deal 32"  
IR/LED board

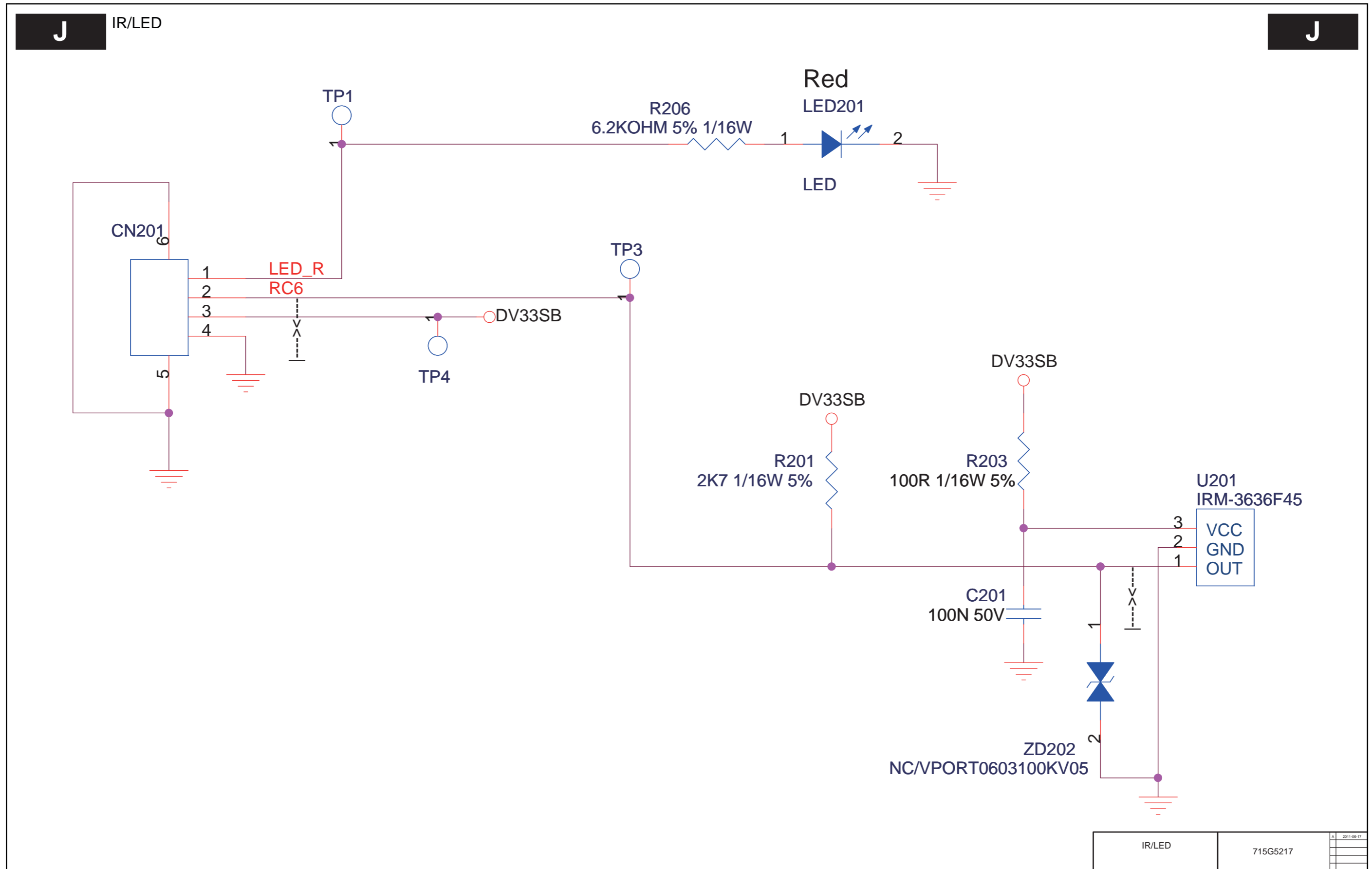

IR/LED	715G5217	A	2011-06-17

19121\_513\_110914.eps  
110914

IR/LED board layout

Layout IR/LED Board (Top Side)

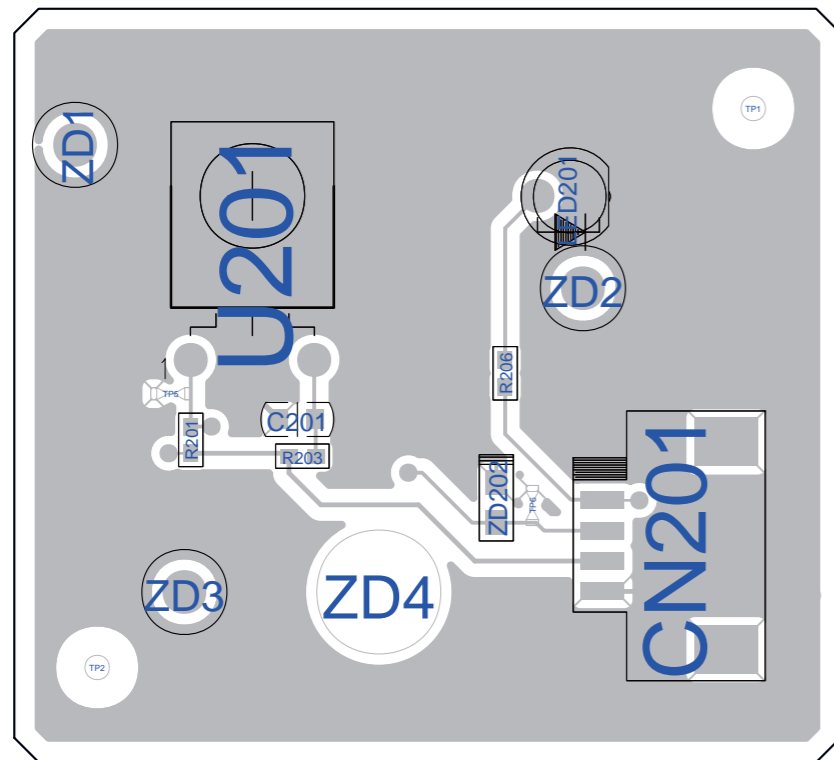

Layout IR/LED Board (Bottom Side)

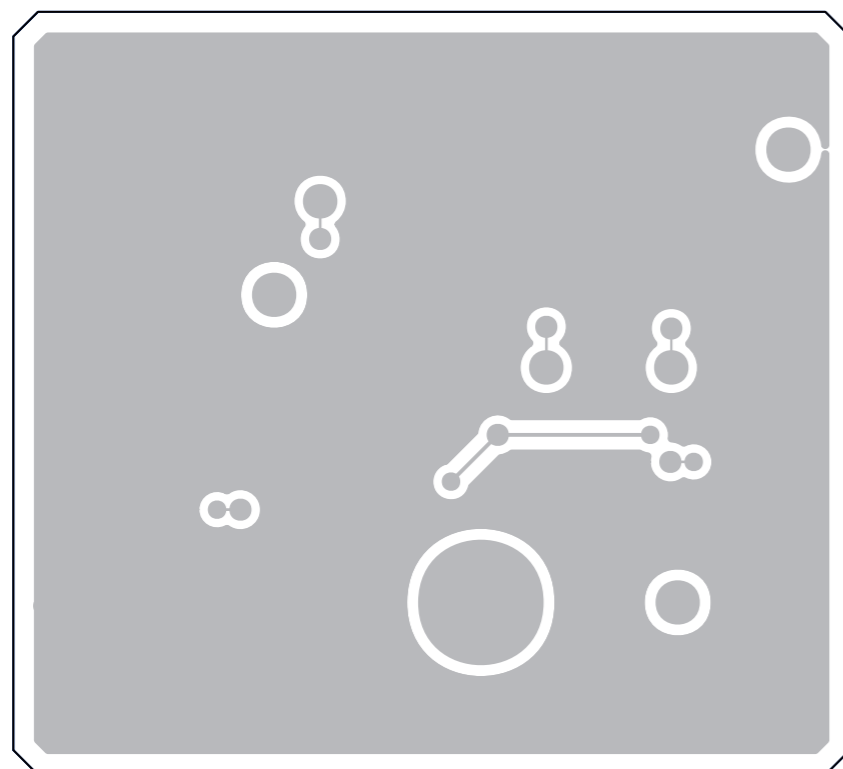

IR/LED board layout top/bottom	715G5217	A	2011-06-17

10-9 E 715G5218 Keyboard Spot Deal  
Keyboard

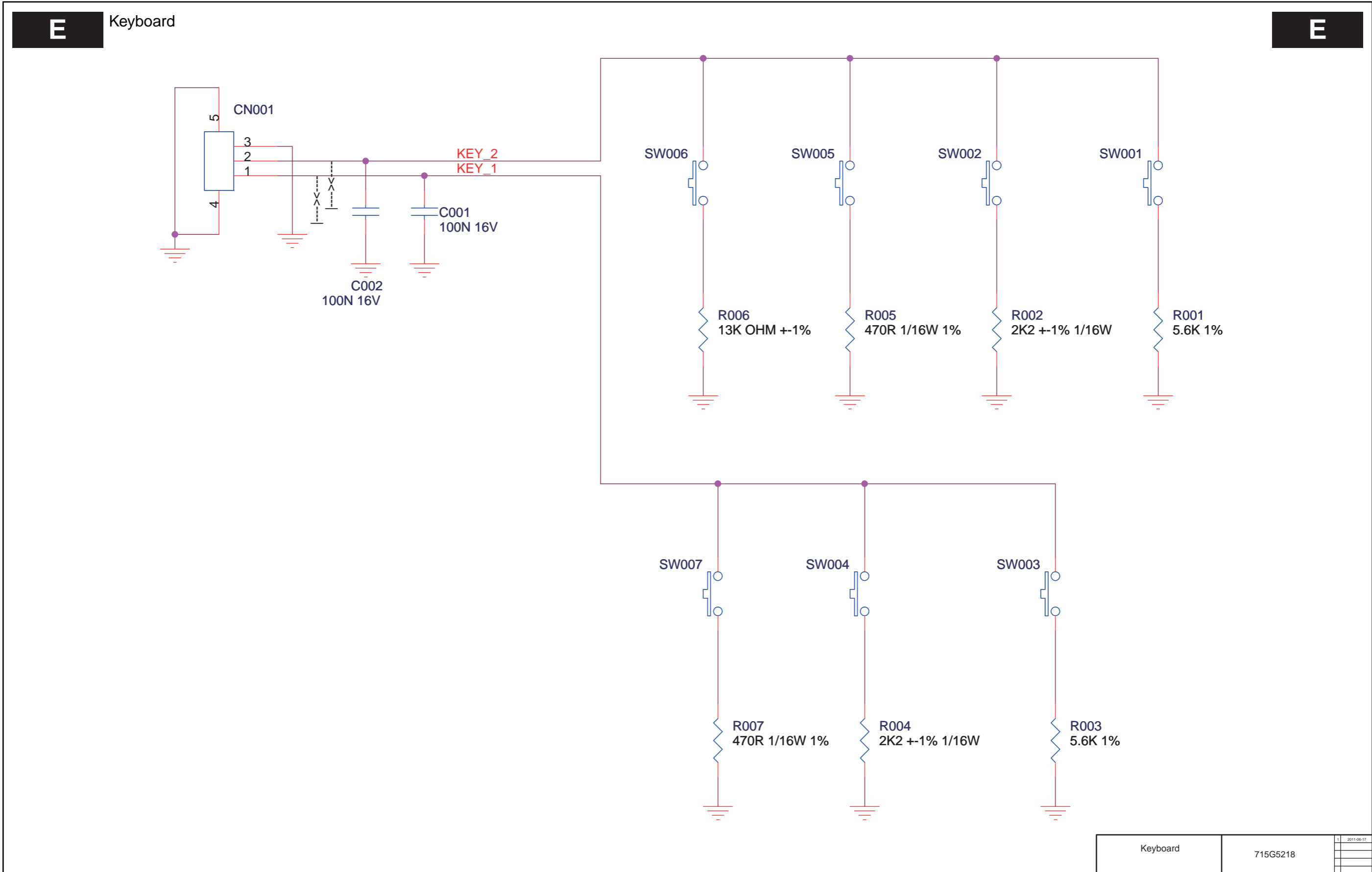

Keyboard	715G5218	1	2011-06-17

Keyboard layout

Layout Keyboard (Top Side)

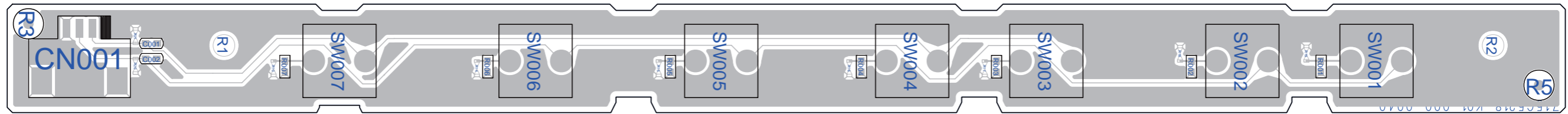

Layout Keyboard (Bottom Side)

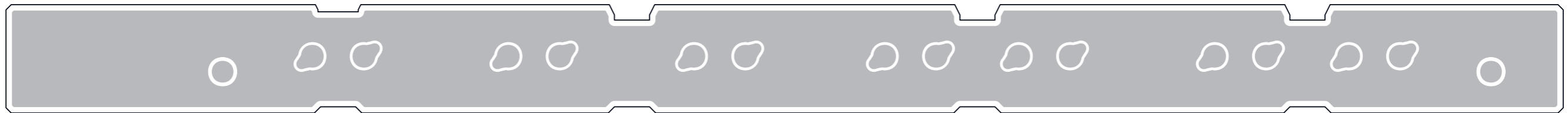

Keyboard layout top/bottom	715G5218	1	2011-06-17

# 11. Styling Sheets

## 11-1 Golden horse 19"

Golden horse 19"

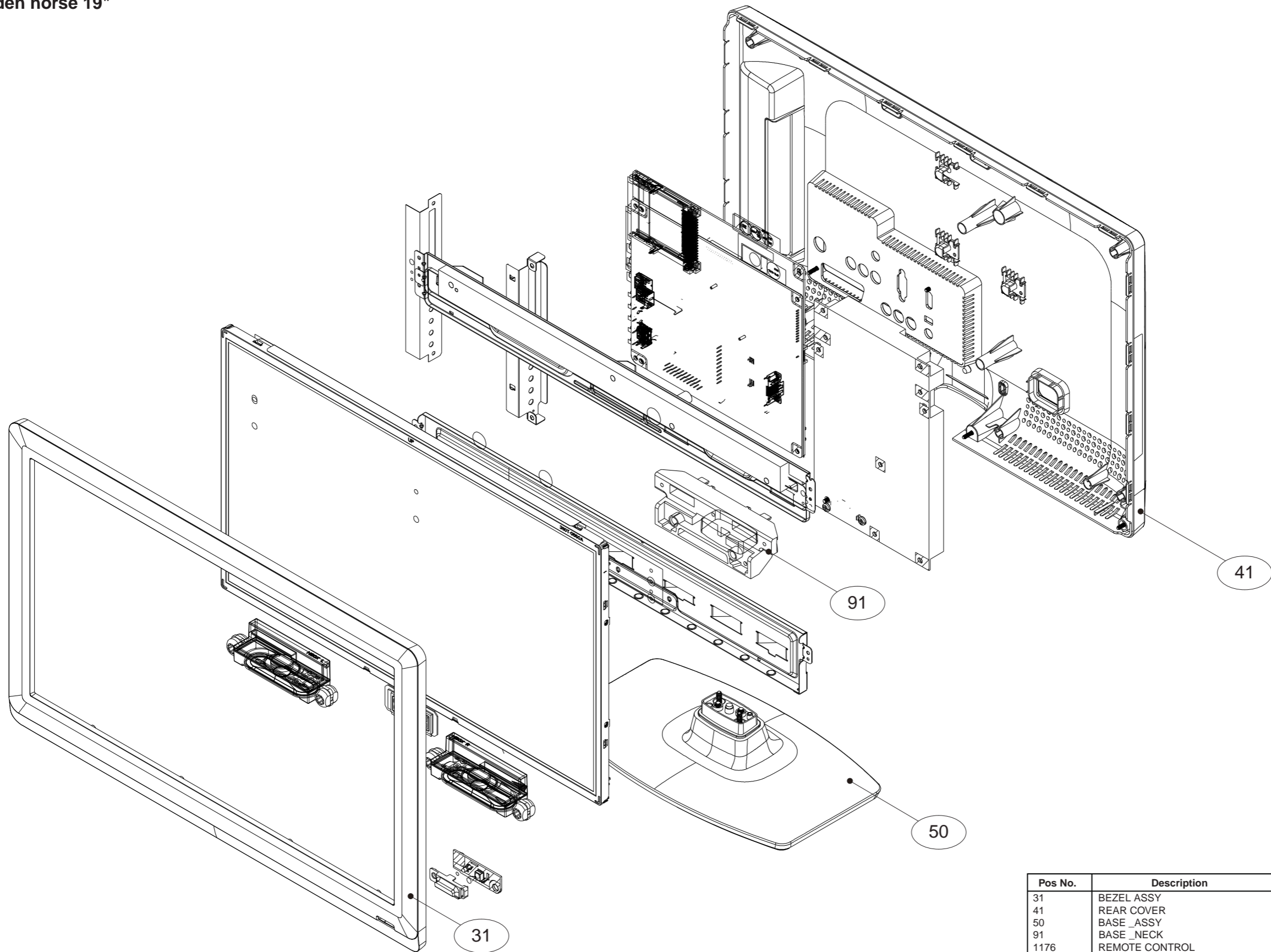

Pos No.	Description	Remarks
31	BEZEL ASSY	
41	REAR COVER	
50	BASE_ASSY	
91	BASE_NECK	
1176	REMOTE CONTROL	

FOR ELECTRICAL PARTS/ASSEMBLIES SEE WIRING DIAGRAM CHAPTER 9



11-2 Golden horse 22"

Golden horse 22"

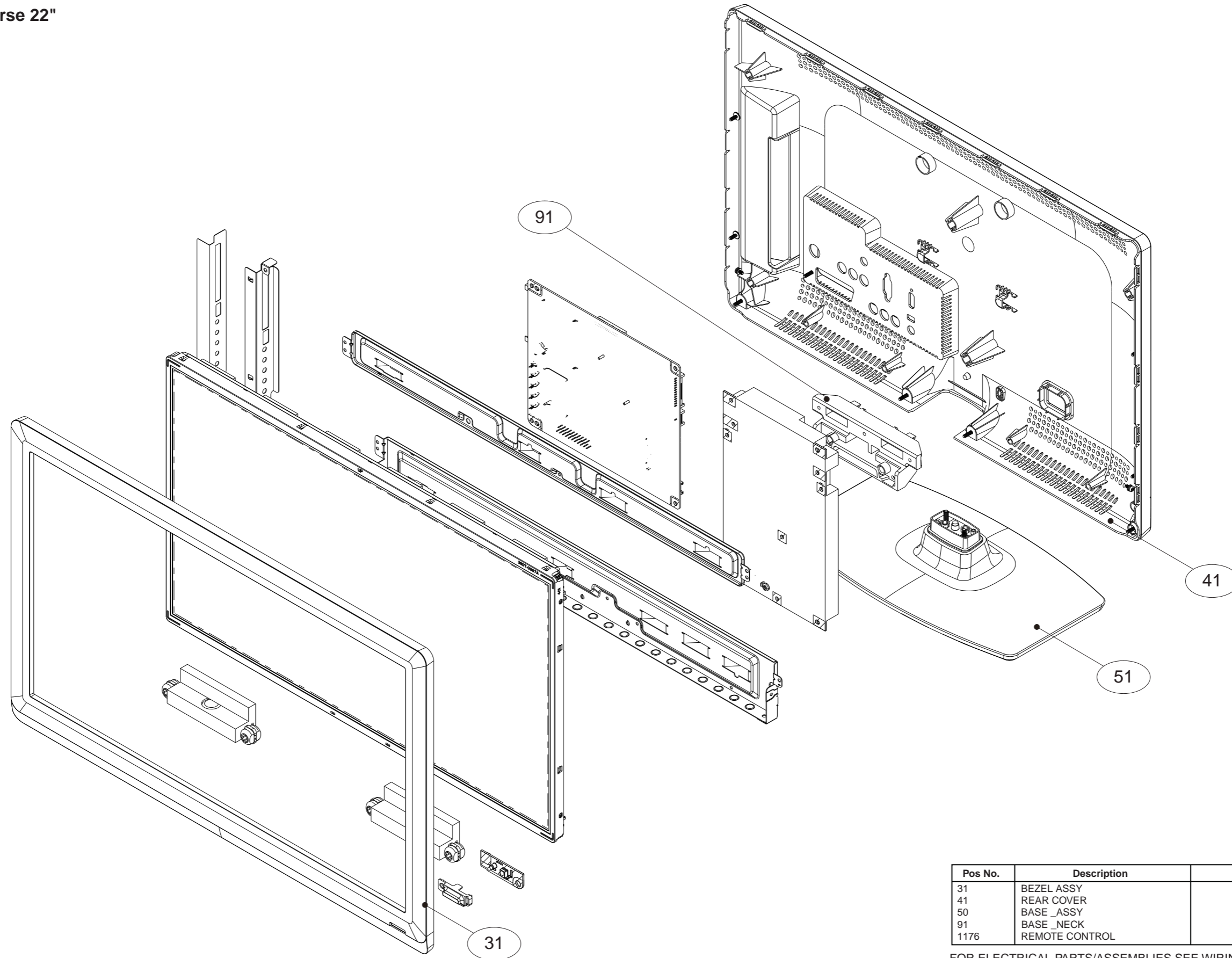

Pos No.	Description	Remarks
31	BEZEL ASSY	
41	REAR COVER	
50	BASE_ASSY	
91	BASE_NECK	
1176	REMOTE CONTROL	

FOR ELECTRICAL PARTS/ASSEMBLIES SEE WIRING DIAGRAM CHAPTER 9

11-3 Spot Deal 22"

Spot Deal 22"

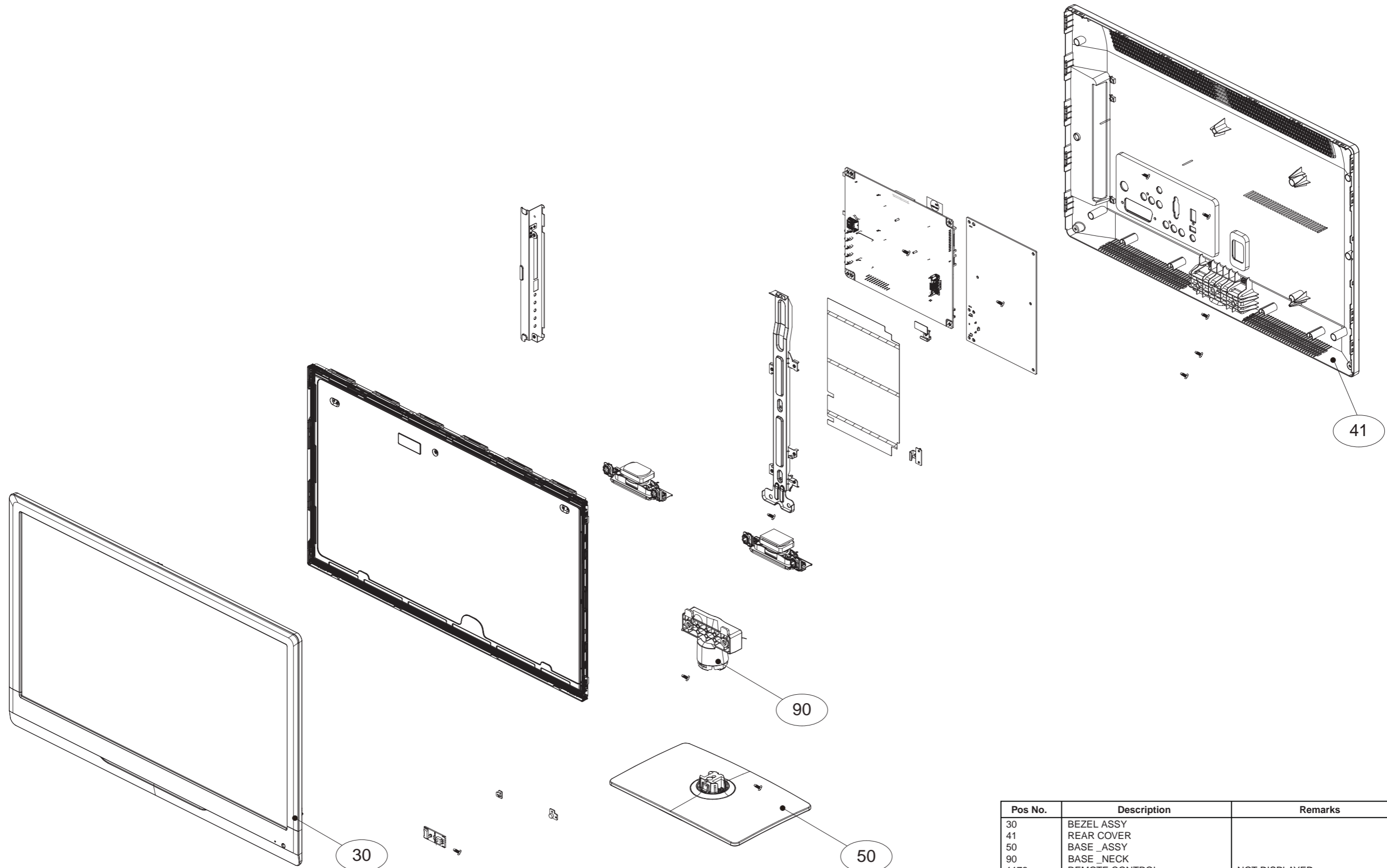

Pos No.	Description	Remarks
30	BEZEL ASSY	
41	REAR COVER	
50	BASE_ASSY	
90	BASE_NECK	
1176	REMOTE CONTROL	NOT DISPLAYED

FOR ELECTRICAL PARTS/ASSEMBLIES SEE WIRING DIAGRAM CHAPTER 9

11-4 Golden horse 26"

Golden horse 26"

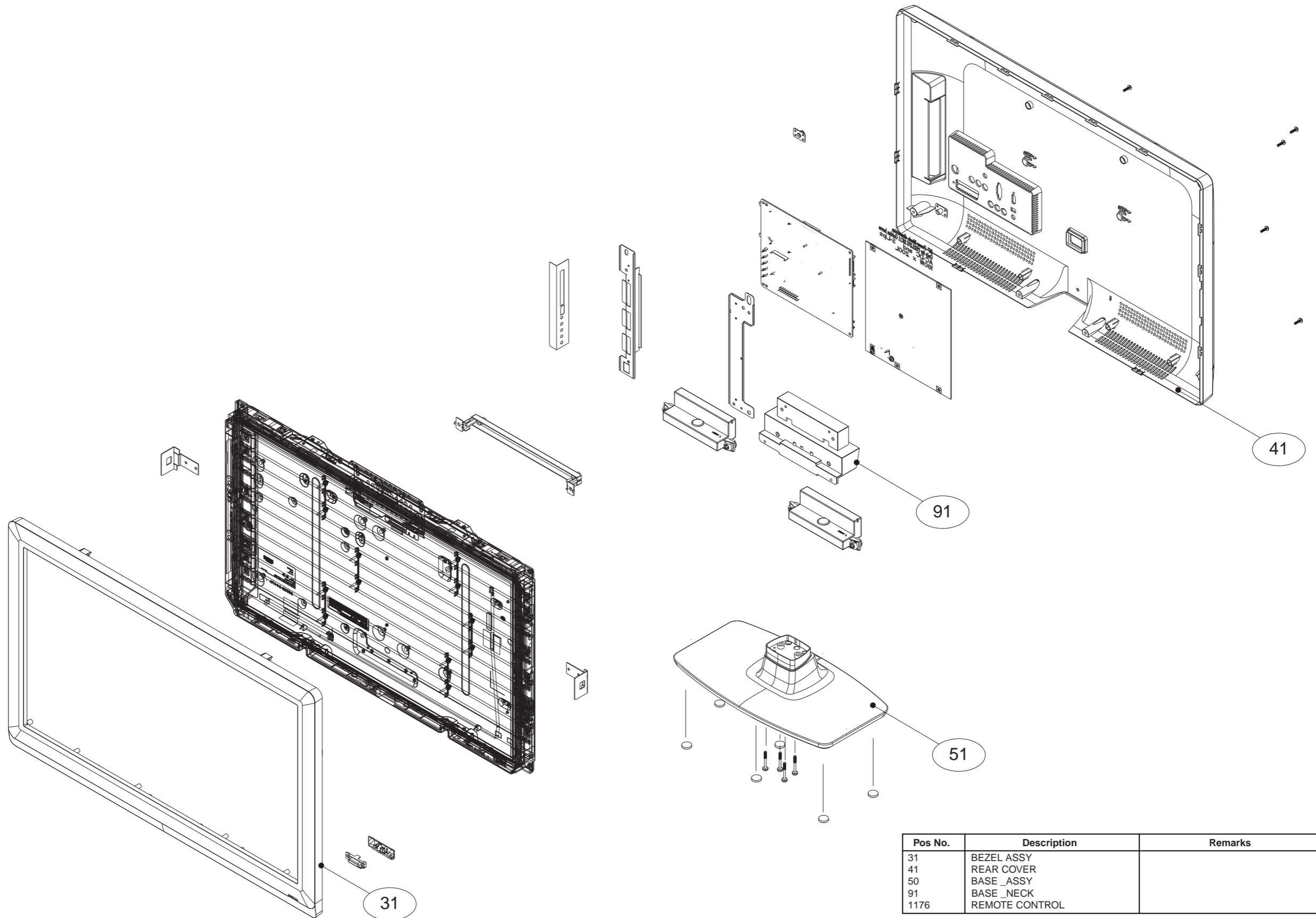

Pos No.	Description	Remarks
31	BEZEL ASSY	
41	REAR COVER	
50	BASE_ASSY	
91	BASE_NECK	
1176	REMOTE CONTROL	

FOR ELECTRICAL PARTS/ASSEMBLIES SEE WIRING DIAGRAM CHAPTER 9

11-5 Spot Deal 32"

Spot Deal 32"

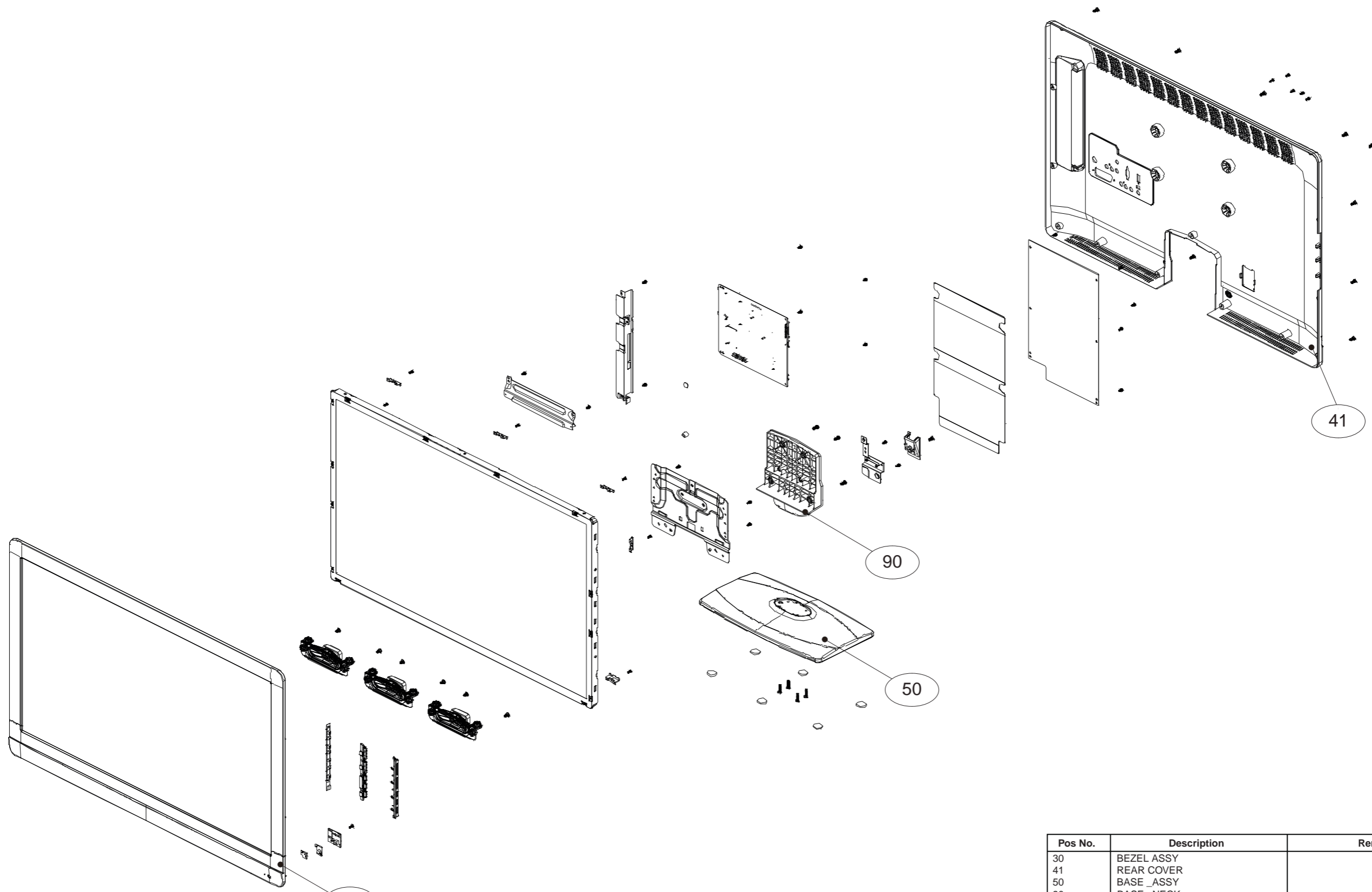

Pos No.	Description	Remarks
30	BEZEL ASSY	
41	REAR COVER	
50	BASE_ASSY	
90	BASE_NECK	
1176	REMOTE CONTROL	NOT DISPLAYED

FOR ELECTRICAL PARTS/ASSEMBLIES SEE WIRING DIAGRAM CHAPTER 9

19121\_801\_110914.eps  
110922