

Service Manual

ViewSonic VA703b / VA703m
Model No VS11280
17" Color TFT LCD Display

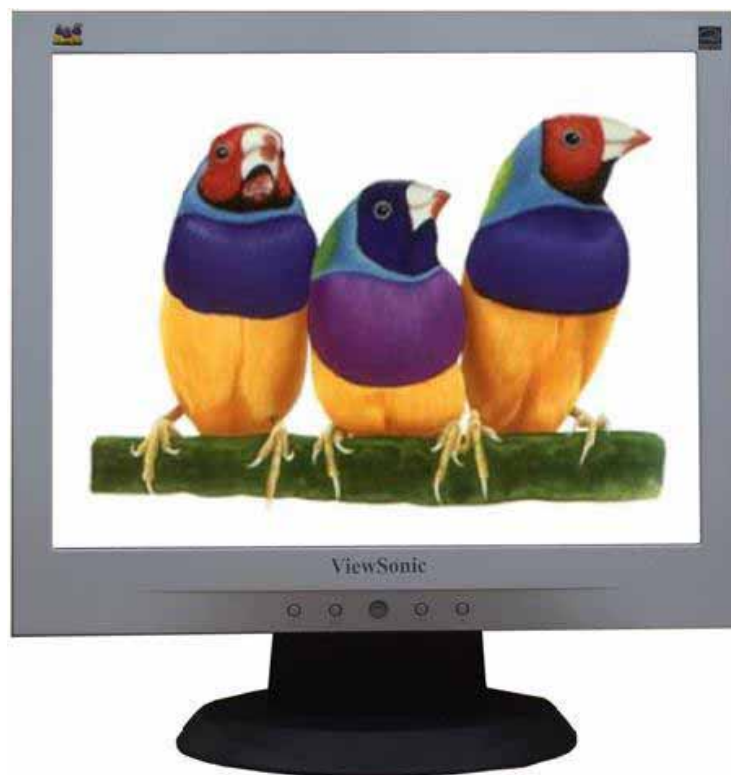

Manufacture Date: May-10-06

Copyright Information

Copyright © ViewSonic® Corporation, 2006. All rights reserved.

Macintosh and Power Macintosh are registered trademarks of Apple Computer, Inc.

Microsoft, Windows, Windows NT, and the Windows logo are registered trademarks of Microsoft Corporation in the United States and other countries.

ViewSonic, the three birds logo, OnView, ViewMatch, and ViewMeter are registered trademarks of ViewSonic Corporation.

VESA is a registered trademark of the Video Electronics Standards Association. DPMS and DDC are trademarks of VESA.

ENERGY STAR® is a registered trademark of the U.S. Environmental Protection Agency (EPA). As an ENERGY STAR® partner, ViewSonic Corporation has determined that this product meets the ENERGY STAR® guidelines for energy efficiency.

Disclaimer: ViewSonic Corporation shall not be liable for technical or editorial errors or omissions contained herein; nor for incidental or consequential damages resulting from furnishing this material, or the performance or use of this product.

In the interest of continuing product improvement, ViewSonic Corporation reserves the right to change product specifications without notice. Information in this document may change without notice.

No part of this document may be copied, reproduced, or transmitted by any means, for any purpose without prior written permission from ViewSonic Corporation.

Copyright © ViewSonic® Corporation, 2006. All rights reserved. No part of this publication may be reproduced, transmitted, transcribed, stored in a retrieval system, or translated into any language or manual or otherwise, without the prior written permission of ViewSonic® Corporation.

Revision History

Revision	Date	Description of changes	Approval
A00	May-10-06	Initial Release	YG.WANG

TABLE OF CONTENTS

1. Precautions And Safety Notices	4
2. Specification	7
3. Front Panel Control And Indicators	9
4. Circuit Description	15
5. Adjustment Procedure	23
6. Troubleshooting Flow Chart	42
7. Recommended Spare Parts List	43
8. Exploded Diagram And Spare Parts List	59
9. Disassemble Process	63
10. Block Diagram	68
11. Schematic Diagram	69
12. PCB Layout Diagram	78

1. Precautions And Safety Notices

1.1 SAFETY PRECAUTIONS

This monitor is manufactured and tested on a ground principle that a user's safety comes first. However, improper use or installation may cause damage to the monitor as well as the user. Carefully go over the following WARNINGS before installing and keep this guide handy.

WARNINGS

- . This monitor should be operated only at the correct power sources indicated on the label on the rear end of the monitor. If you're unsure of the power supply in your residence, consult you local dealer or power company.
- . Use only the special power adapter that comes with this monitor for power input.
- . Do not try to repair the monitor your self as it contains no user-serviceable parts. This monitor should only be repaired by a qualified technician.
- . Do not remove the monitor cabinet. There is high-voltage parts inside that may cause electric shock to human bodies, even when the power cord is unplugged.
- . Stop using the monitor if the cabinet is damaged. Have it checked by a service technician.
- . Put your monitor only in a clean, dry environment. If it gets wet, unplug the power cable immediately and consult your service technician.
- . Always unplug the monitor before cleaning it .Clean the cabinet with a clean, dry cloth. Apply non-ammonia based cleaner onto the cloth, not directly onto the glass screen.
- . Keep the monitor away from magnetic objects, motors, TV sets, and transformer.
- . Do not place heavy objects on the monitor or power cord.







1.2 PRODUCT SAFETY NOTICE

Many electrical and mechanical parts in this chassis have special safety visual inspections and the protection afforded by them cannot necessarily be obtained by using replacement components rated for higher voltages, wattage, etc. Before replacing any of these components read the parts list in this manual carefully. The use of substitute replacement parts which do not have the same safety characteristics as specified in the parts list may create shock, fire ,or other hazards.

1.3 SERVICE NOTES

1. When replacing parts or circuit boards, clamp the lead wires around terminals before soldering.
2. When replacing a high wattage resistor(more than 1W of metal oxide film resistor) in circuit board, keep the resistor about 5mm away from circuit board.
3. Keep wires away from high voltage, high temperature components and sharp edges.
4. Keep wires in their original position so as to reduce interference.
5. Usage of this product please refer to also user's manual.

1.4 HANDING AND PLACING METHODS

Correct Methods:	Incorrect Methods:
<p>Only touch the metal frame of the LCD panel or the front cover of the monitor. Do not touch the surface of the polarizer.</p>	<p>Surface of the LCD panel is pressed by fingers and that may cause "Mura."</p>
	
	
<p>Take out the monitor with cushions</p>	<p>Taking out the monitor by grasping the LCD panel. That may cause "Mura."</p>
	

Place the monitor on a clean and soft foam pad.



Placing the monitor on foreign objects. That could scratch the surface of the panel or cause "Mura."



Place the monitor on the lap, the panel surface must be upwards.



The panel is placed facedown on the lap. That may cause "Mura."



2. Specification

2.1 PRODUCT SPECIFICATIONS

LCD Panel	17.0" TFT
Recommend Resolution	1280 x 1024@60Hz
Pixel Dimension	0.264(H) x 0.264(V)mm
LCD Display Color	16.2M Colors (6+2bit panel)
Viewing Angle	Horizontal: 150 ° Vertical: 135 °
Contrast Ratio	700 : 1 (Typ.)
Brightness	300 cd/m ² (Typ.)
Response Time	8ms(Typ.)
Active Display Area	337.92mm(H) x 270.336mm(V)
Maximum Pixel Clock	135 MHz
Horizontal Frequency	30 – 82 kHz
Vertical Refresh Rate	50 – 85 Hz.
Temperature	Operating: 0°C to +40°C Storage: -20°C to +60°C
Power Management	Energy Star compliant VESA DPMS compatible <1 W
Power	Input Voltage : 100V~240V Consumption: ON Mode < 35 W (max) POWER SAVING < 2W OFF < 1W

2.2 INTERFACE DESCRIPTION

D-SUB 15 PIN CONNECTOR

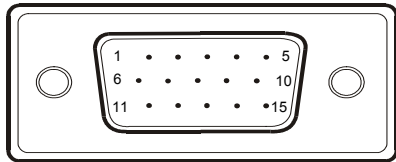

Pin Number	Pin Function
1	Red video input
2	Green video input
3	Blue video input
4	No Connection
5	Ground
6	Red video ground
7	Green video ground
8	Blue video ground
9	+5V
10	H/V sync ground
11	No connection
12	(SDA)
13	Horizontal sync (Composite sync)
14	Vertical sync
15	(SCL)

SIGNAL LEVEL

CONNECTOR	SIGNAL	DESCRIPTION
R	RED	0.7vp-p(VIDEO)
G	GREEN	0.7vp-p(VIDEO)
B	BLUE	0.7vp-p(VIDEO)
H	H/SYNC	TTL positive or negative
V	V/SYNC	TTL positive or negative
SDA	DDC1/2B	TTL
SCL	DDC1/2B	TTL

3. Front Panel Function Controls And Indicators

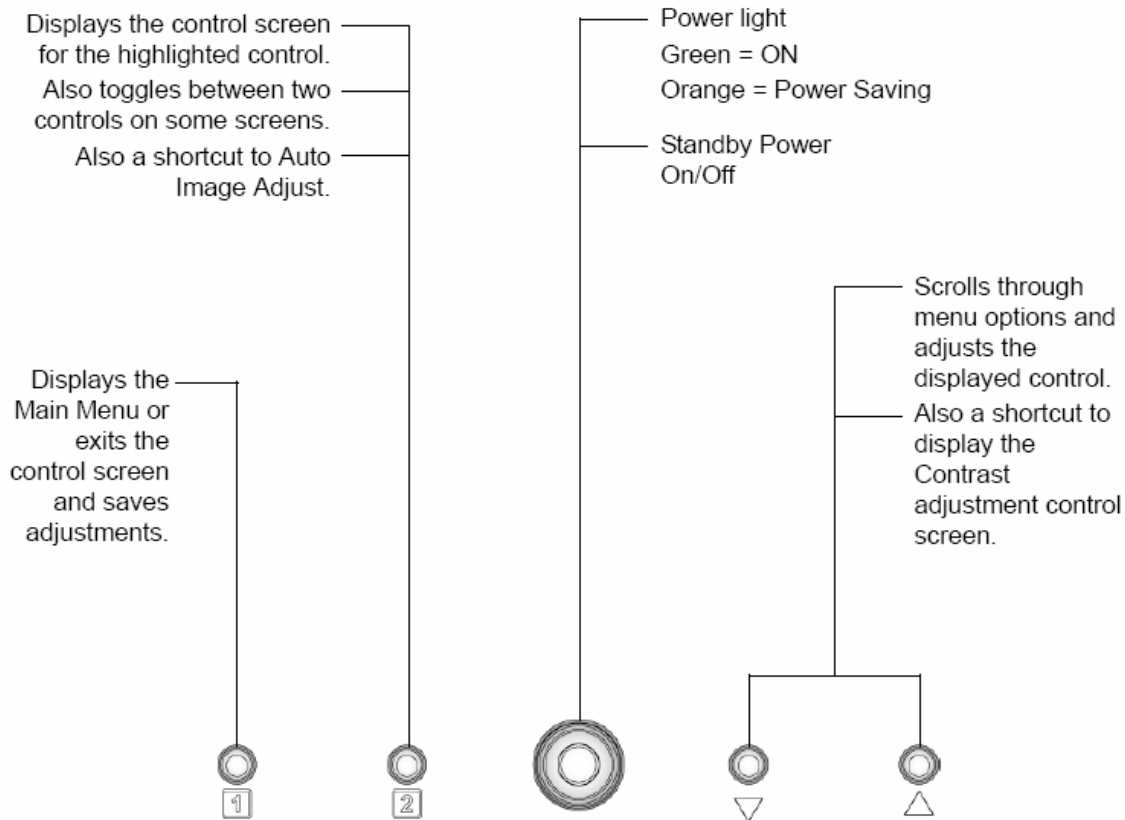
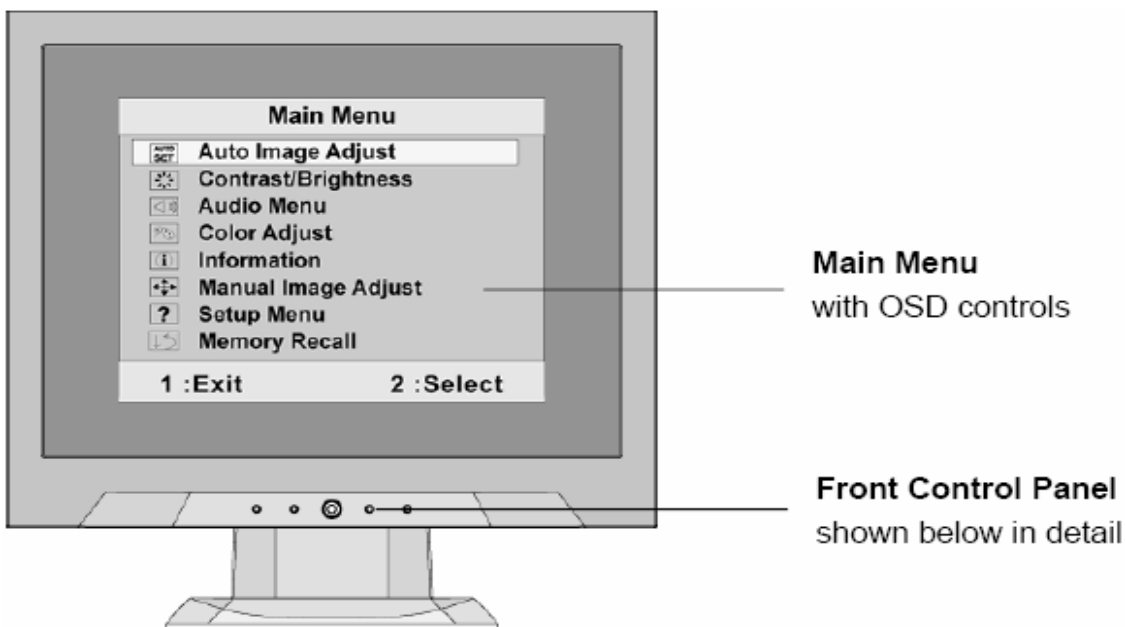

Do the following to adjust the display setting:

1. To display the Main Menu, press button [1].

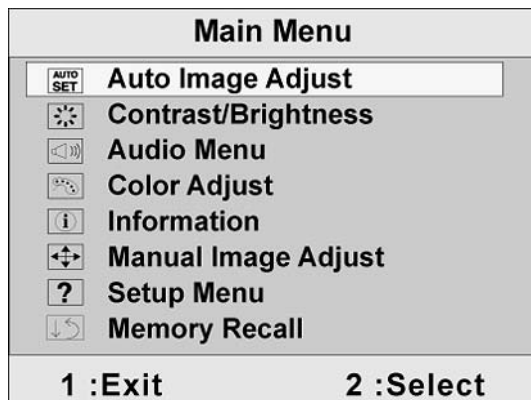

NOTE: All OSD menus and adjustment screens disappear automatically after about 15 seconds. This is adjustable through the OSD timeout setting in the setup menu.

2. To select a control to adjust, press ▲ or ▼ to scroll up or down in the Main Menu.
3. After the desired control is selected, press button [2]. A control screen like the one shown below appears.

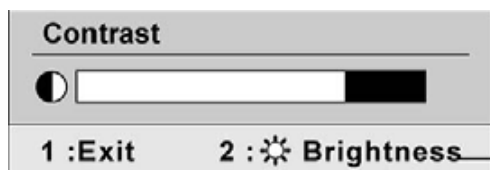

The line at the bottom of the screen shows the current functions of buttons 1 and 2: Exit or select the Brightness control.

4. To adjust the control, press the up ▲ or ▼ down T buttons.
5. To save the adjustments and exit the menu, press button [1] *twice*.





The following tips may help you optimize your display:















- Adjust the computer's graphics card so that it outputs a 1024 x 768 @ 60Hz video signal to the LCD display. (Look for instructions on "changing the refresh rate" in the graphics card's user guide.)
- If necessary, make small adjustments using H. POSITION and V. POSITION until the screen image is completely visible. (The black border around the edge of the screen should barely touch the illuminated "active area" of the LCD display.)

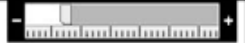
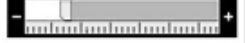



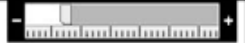
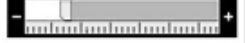

Downloaded from www.Manualslib.com manuals search engine

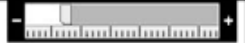
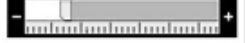
Main Menu Controls

Adjust the menu items shown below by using the up ▲ and down ▼ buttons.

Control	Explanation
	<p>Auto Image Adjust automatically sizes, centers, and fine tunes the video signal to eliminate waviness and distortion. Press the [2] button to obtain a sharper image.</p> <p>NOTE: Auto Image Adjust works with most common video cards. If this function does not work on your LCD display, then lower the video refresh rate to 60 Hz and set the resolution to its pre-set value.</p>
	<p>Contrast adjusts the difference between the image background (black level) and the foreground (white level).</p>
	<p>Brightness adjusts background black level of the screen image.</p>
	<p>Audio Adjust (For VA703m only)</p> <p>Volume increases the volume, decreases the volume, and mutes the audio. Mute temporarily silences audio output.</p>
	<p>Color Adjust provides several color adjustment modes, including preset color temperatures and a User Color mode which allows independent adjustment of red (R), green (G), and blue (B). The factory setting for this product is 6500K (6500 Kelvin).</p> <div data-bbox="407 1146 862 1419" style="border: 1px solid gray; padding: 5px; margin: 10px 0;"> <p style="text-align: center;">Color Adjust</p> <p>sRGB</p> <p>9300K</p> <p>• 6500K</p> <p>5400K</p> <p>User Color</p> <hr/> <p>1 :Exit 2 :Select</p> </div> <p>sRGB-This is quickly becoming the industry standard for color management, with support being included in many of the latest applications. Enabling this setting allows the LCD display to more accurately display colors the way they were originally intended. Enabling the intended. Enabling the sRGB setting will cause Contrast and Brightness adjustments to be disabled.</p> <p>9300K-Adds blue to the screen image for cooler white (used in most office settings with fluorescent lighting).</p> <p>6500K-Adds red to the screen image for warmer white and richer red.</p> <p>5400K-Adds green to the screen image for a darker color.</p> <p>User Color Individual adjustments for red (R), green (G), and blue (B).</p>

	<p>1. To select color (R, G or B) press button [2]. 2. To adjust selected color, press ▼ and ▲. Important: If you select RECALL from the Main Menu when the product is set to a Preset Timing Mode, colors return to the 6500K factory preset.</p>																
	<p>Information displays the timing mode (video signal input) coming from the graphics card in the computer, the LCD model number, the serial number, and the ViewSonic® website URL. See your graphics card's user guide for instructions on changing the resolution and refresh rate (vertical frequency). NOTE: VESA 1280 x 1024 @ 60Hz (recommended) means that the resolution is 1024 x 768 and the refresh rate is 60 Hertz.</p> <div data-bbox="409 653 880 1012" style="border: 1px solid black; padding: 5px;"> <p style="text-align: center;">Information</p> <table style="width: 100%; border-collapse: collapse;"> <tr> <td style="padding: 2px;">H. Frequency: XX</td> <td style="padding: 2px; text-align: right;">kHz</td> </tr> <tr> <td style="padding: 2px;">V. Frequency: XX</td> <td style="padding: 2px; text-align: right;">Hz</td> </tr> <tr> <td style="padding: 2px;">Pixel Clock: XX</td> <td style="padding: 2px; text-align: right;">MHz</td> </tr> <tr> <td style="padding: 2px;">Resolution: XXXXXXXX</td> <td></td> </tr> <tr> <td style="padding: 2px;">Model No: XXXXXXXXXXXX</td> <td></td> </tr> <tr> <td style="padding: 2px;">Serial No:</td> <td></td> </tr> <tr> <td colspan="2" style="padding: 2px; text-align: center;">www.ViewSonic.com</td> </tr> <tr> <td style="padding: 2px;">1 :Exit</td> <td style="padding: 2px;">2 :Select</td> </tr> </table> </div>	H. Frequency: XX	kHz	V. Frequency: XX	Hz	Pixel Clock: XX	MHz	Resolution: XXXXXXXX		Model No: XXXXXXXXXXXX		Serial No:		www.ViewSonic.com		1 :Exit	2 :Select
H. Frequency: XX	kHz																
V. Frequency: XX	Hz																
Pixel Clock: XX	MHz																
Resolution: XXXXXXXX																	
Model No: XXXXXXXXXXXX																	
Serial No:																	
www.ViewSonic.com																	
1 :Exit	2 :Select																
	<p>Manual Image Adjust displays the Manual Image Adjust menu.</p> <div data-bbox="409 1094 959 1373" style="border: 1px solid black; padding: 5px;"> <p style="text-align: center;">Manual Image Adjust</p> <table style="width: 100%; border-collapse: collapse;"> <tr> <td style="padding: 2px;"> H. / V. Position</td> </tr> <tr> <td style="padding: 2px;"> H. Size</td> </tr> <tr> <td style="padding: 2px;"> Fine Tune</td> </tr> <tr> <td style="padding: 2px;"> Sharpness</td> </tr> <tr> <td style="padding: 2px;">1 :Exit</td> <td style="padding: 2px;">2 :Select</td> </tr> </table> </div> <p>H. Size (Horizontal Size) adjusts the width of the screen image.</p> <p>H./V. Position (Horizontal/Vertical Position) moves the screen image left or right and up or down.</p> <div data-bbox="409 1535 896 1759" style="border: 1px solid black; padding: 5px;"> <p style="text-align: center;">H./V. Position</p> <table style="width: 100%; border-collapse: collapse;"> <tr> <td style="padding: 2px;">H. Position</td> <td style="padding: 2px; text-align: center;">  </td> </tr> <tr> <td style="padding: 2px;">V. Position</td> <td style="padding: 2px; text-align: center;">  </td> </tr> <tr> <td style="padding: 2px;">- : ↓</td> <td style="padding: 2px; text-align: right;">+ : ↑</td> </tr> <tr> <td style="padding: 2px;">1: Exit</td> <td style="padding: 2px;">2: Select</td> </tr> </table> </div> <p>Fine Tune sharpens the focus by aligning text and/or graphics with pixel boundaries.</p>	 H. / V. Position	 H. Size	 Fine Tune	 Sharpness	1 :Exit	2 :Select	H. Position		V. Position		- : ↓	+ : ↑	1: Exit	2: Select		
 H. / V. Position																	
 H. Size																	
 Fine Tune																	
 Sharpness																	
1 :Exit	2 :Select																
H. Position																	
V. Position																	
- : ↓	+ : ↑																
1: Exit	2: Select																

	<p>NOTE: Try Auto Image Adjust first.</p> <p>Sharpness adjusts the clarity and focus of the screen image.</p>
<p style="text-align: center; border: 1px solid black; width: 30px; margin: 0 auto;">?</p>	<p>Setup Menu displays the menu shown below:</p> <div style="border: 1px solid black; padding: 5px; margin: 10px 0;"> <p style="text-align: center;">Setup Menu</p> <p>  Language Select  Resolution Notice  OSD Position  OSD Timeout  Input Select </p> <p style="text-align: center;"> 1 :Exit 2 :Select </p> </div> <p>Language Select allows the user to choose the language used in the menus and control screens.</p> <p>Resolution Notice allows the user to enable or disable this notice.</p> <div style="border: 1px solid black; padding: 5px; margin: 10px 0;"> <p style="text-align: center;">Resolution Notice</p> <p style="text-align: center;">For the best quality, change the resolution to 1024 x 768</p> <p style="text-align: center;">Press "1" to clear message Press "2" to disable message</p> <p style="text-align: center;"> 1 :Exit 2 :Select </p> </div> <p>Resolution Notice advises the optimal resolution to use.</p> <p>OSD Position allows the user to move the OSD menus and control screens.</p> <p>OSD Timeout sets the length of time the OSD screen is displayed. For example, with a "15 second" setting, if control is not pushed within 15 seconds, the display screen disappears.</p> <p>OSD Background allows the user to turn the OSD background On or Off.</p>
<p style="text-align: center; border: 1px solid black; width: 30px; margin: 0 auto;">  </p>	<p>Memory Recall returns the adjustments back to factory settings if the display is operating in a factory Preset Timing Mode listed in the Specifications of this manual.</p> <p>Exception: This control does not affect changes made with the User Color control, Language Select or Power Lock setting.</p>

SHORT CUTS FUNCTION FROM THE BUTTONS

[1]	Main Menu
[2]	Auto Image Adjust
[▼] or [▲]	To immediately activate Contrast menu. It should be change to Brightness OSD by push button [2]
[▼] + [▲]	recall both of Contrast and Brightness to default
[1] + [2]	toggle 720x400 and 640x400 mode when input 720x400 or 640x400 mode
[1] + [▼] + [▲] (keep pushing 5 sec)	White Balance (Not shown on user's guide)
[1] + [▼]	Power Lock
[1] + [▲]	OSD Lock
Remark : All the short cuts function are only available while OSD off	

4. Circuit Description

4.1 LCD MONITOR DESCRIPTION

The LCD MONITOR will contain a Main Board, an Power Board, Key Board which house the flat panel control logic, brightness control logic and DDC.

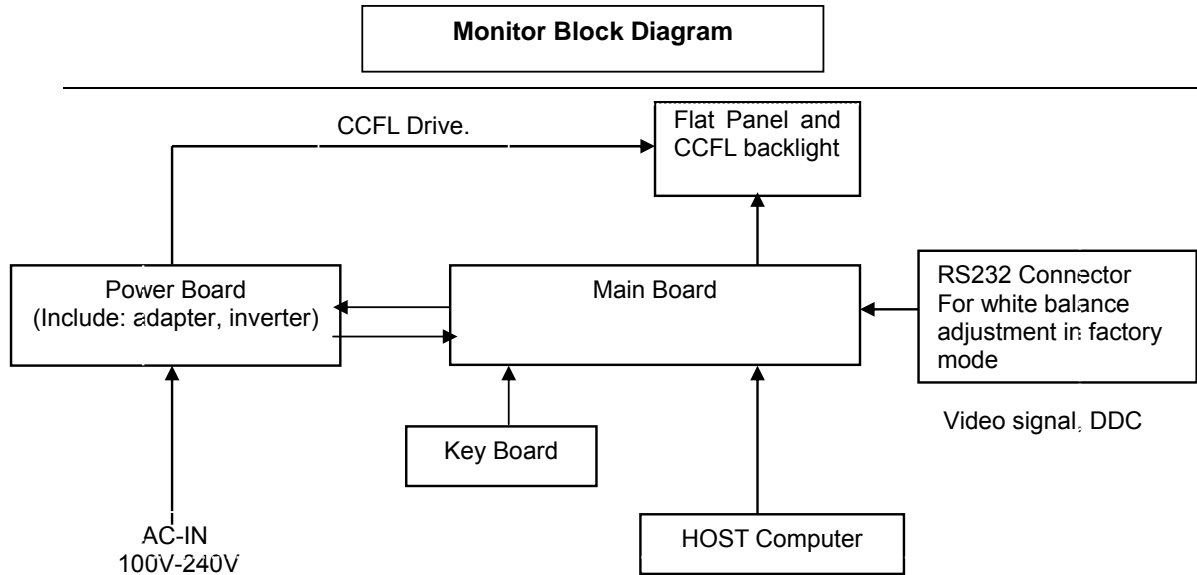

4.2 MAIN BOARD BLOCK FUNCTION DESCRIPTION

The main board contains panel control logic, brightness control logic, DDC and DC convert DC circuit and so on.

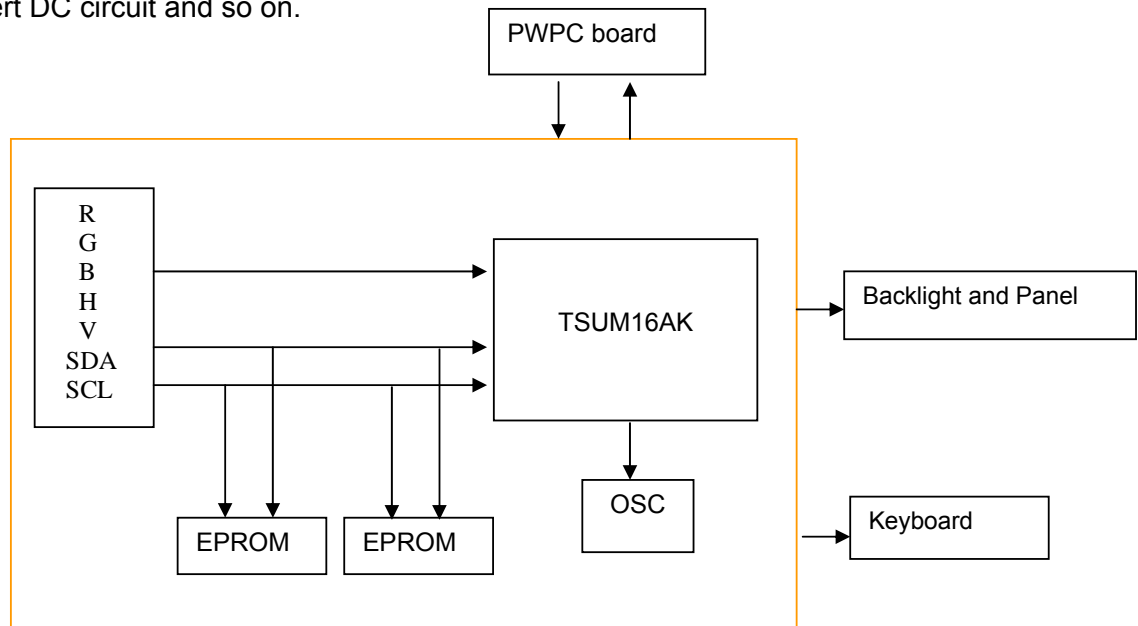

4.3 PWPC BOARD BLOCK FUNCTION DESCRIPTION

PWPC board combines to adapter and inverter, Adapter which commonly consists of bridge rectifier and filter, start circuit, PWM control circuit, protection circuits and convert to 12V, 5V DC voltage by input 90V-240V AC voltage that provide power supply for each chips in the main board and inverter. Inverter is DC TO AC circuit. It changes the 12v DC of power supply to about 600-800v AC that drives the backlight. It mostly consists of starting circuit, PWM controller, DC changing circuit, LC surging circuit, output circuit and protection circuit etc.

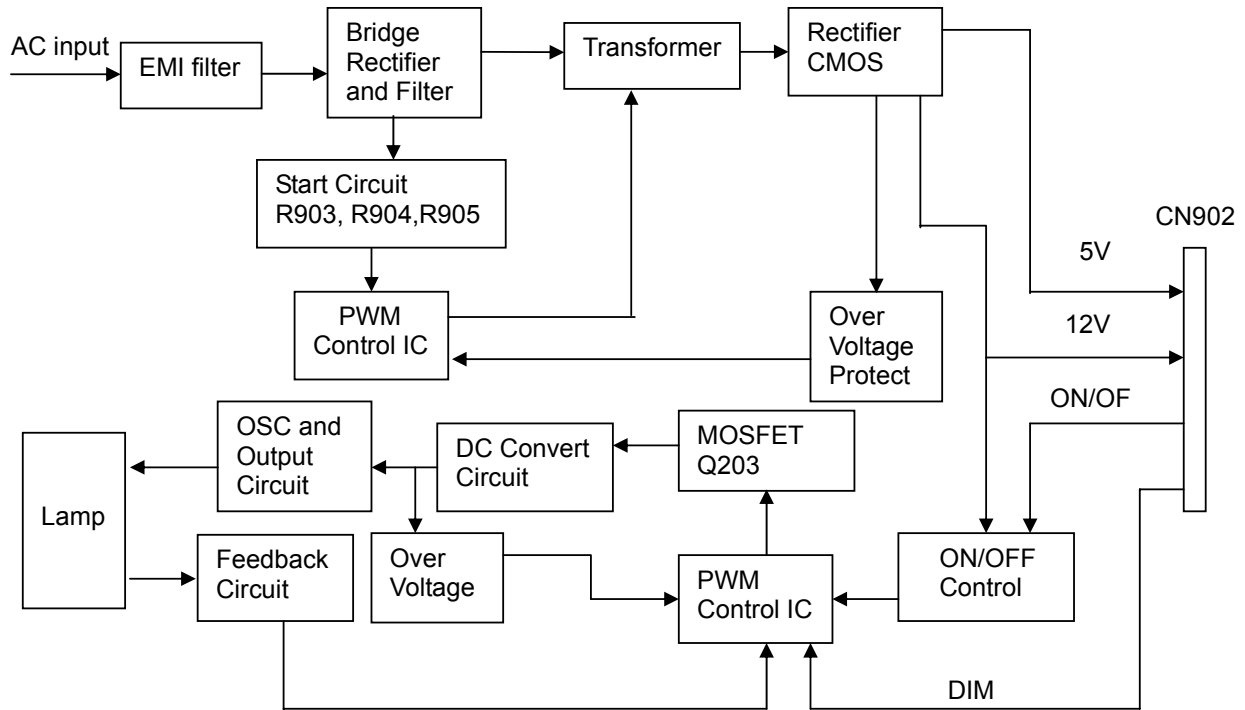

4.4 INTRODUCTION OF IC

TSUM16AK(U401): integrate ADC, OSD, SCALER, MCU, LVDS, convert analog RGB into digital and room and shrink scaling output to LCD panel.

PIN Function:

Pin	Symbol	Description
70	SDO	SPI flash serial data output; Input w/5V-tolerant
71	CSZ	SPI flash chip select; output
72	SCK	SPI flash serial select; output
73	SDI	SPI flash serial data input; output
65	DDCA_SDA/RS232_TX	DDC data for analog interface; 4mA driving strength/UART transmitter/GPIO; I/O w/5V-tolrant
66	DDCA_SDA/RS232_RX	DDC data for analog interface/UART transmitter/GPIO; Input w/5V-tolrant
19	RST	Chip reset; High reset; Input w/5V-tolerant
22	RSTN	Chip reset; Low reset; Input w/5W-toerant
11	VCTRL	Regulator control; Output
63	HSYNCO	Analog HSYNC input
64	VSYNCO	Analog VSYNC input
62	REFP	Internal ADC top de-coupling pin
61	REFM	Internal ADC bottom de-coupling pin
51	REXT	External resistor 390 ohm to AVDD_ADC
21	PWM1	PWM1; 4mA driving strength; Output
29	PWM0	PWM0; 4mA driving strength; Output
4	BYPASS	For External Bypass Capacitor
32	XIN	Xin; Crystal Oscillator Input
33	XOUT	Xout; Crystal Oscillator Output
44、 50、 60	AVDD_ADC	ADC Power 3.3V
52	AVDD_PLL	PLL Power 3.3V
34	AVDD_MPLL	MPLL Power 3.3V
14、 67、 95、 103、 115	VDDP	Digital Output Power 3.3V
12、 68、 97、 117	VDDC	Digital Core Power 1.8V

AIC1084-33PM (U702): DC power convert, used to 5v convert 3.3v.

LT1117-18(U701): DC power convert, used to 5v convert 3.3v.

PM25LV010-25SCE (U402): The PM25LV010 are 512 Kbit/1 Mbits 3.0 Volt-only serial Flash memories. These devices are designed to use a single low voltage, ranging from 2.7 Volt to 3.6 Volt for 25MHz or from 3.0 Volt to 3.6 Volt for 33MHz to perform read, erase and program operations. The devices can be programmed in standard EPROM programmers as well.

PIN Descriptions:

Symbol	Type	Description
CE#	INPUT	Chip Enable: CE# goes low activates the device's internal circuitries for device operation. CE# goes high deselected the device and switches into standby mode to reduce the power consumption. When the device is not selected, data will not be accepted via the serial input pin (SI), and the serial output pin (SO) will remain in a high impedance state.
SCK	INPUT	Serial Data Clock
SI	INPUT	Serial Data Input
SO	OUTPUT	Serial Data Output
GND		Ground
Vcc		Device Power Supply
WP#	INPUT	Write Protect: When the WP# pin brought to low and WPEN bit is "1", all write operations to the status register are inhibited.
HOLD#	INPUT	Hold: Pause serial communication with the master device without resetting the serial sequence.

Circuit Diagram

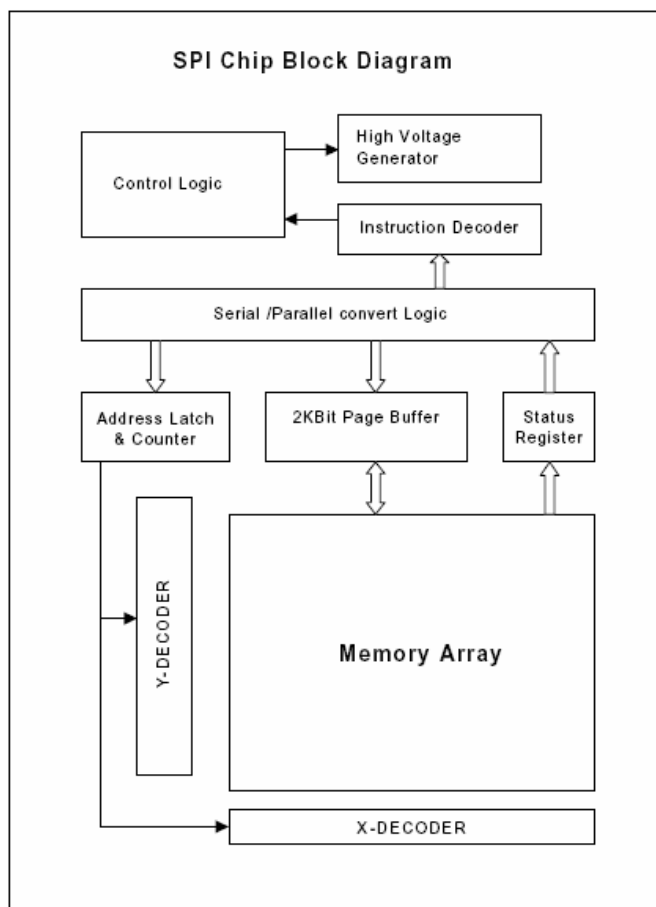

TDA7496L(U201): The TDA7496L is a stereo 2W+2W class AB power amplifier, specially designed for high quality sound, TV and Monitor applications. Features of the UTC TDA7496L include linear volume control, Stand-by and mute functions. The function of each pin and the inside circuit diagram are as follows:

Block Diagram

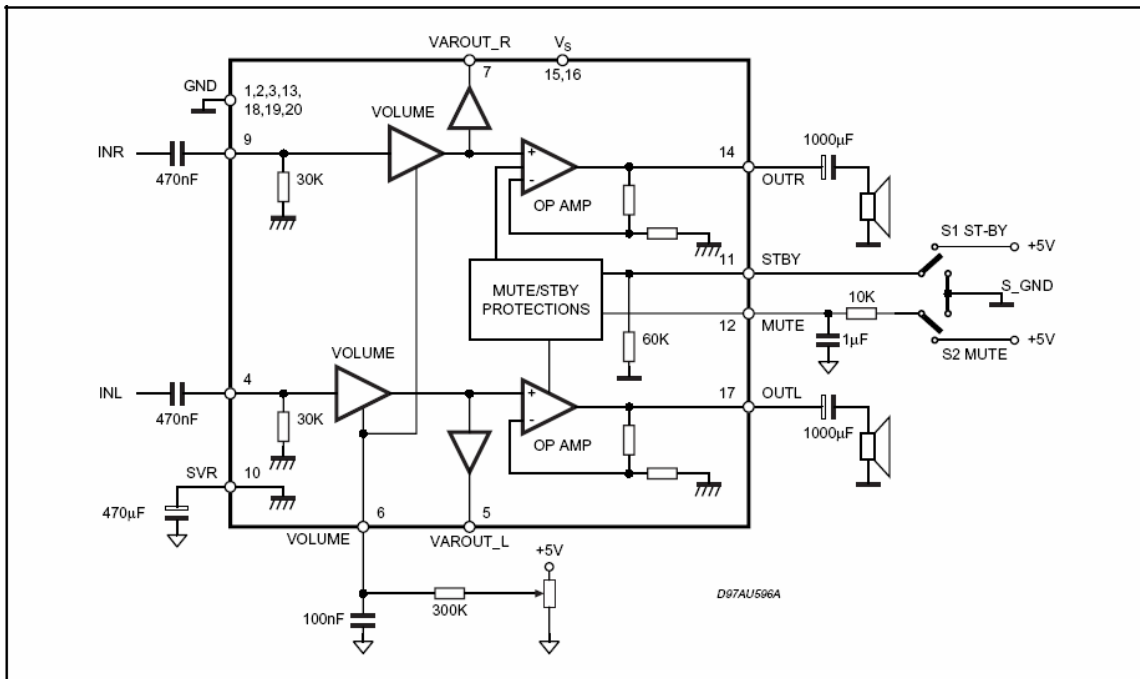

PIN Function

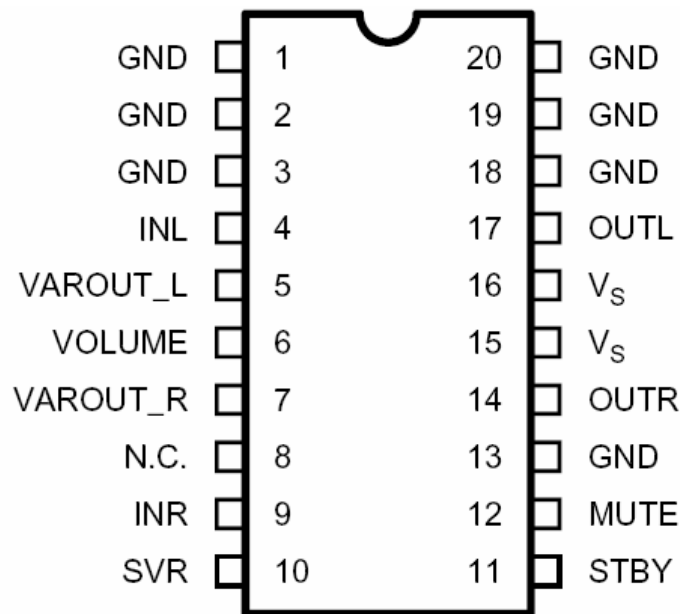

LD7575 PS (IC901): The LD7575 is a current-mode PWM controller with excellent power-saving operation. The embedded over voltage protection, over load protection and the special green-mode control provide the solution for users to design a high performance power circuit easily and etc. The function of each pin and the inside circuit diagram are as follows:

PIN Descriptions:

Pin	Name	Function
1	RT	This pin is to program the switching frequency. By connection a resistor to ground to set the switching frequency.
2	COMP	Voltage feedback pin(same as the COMP pin in UC384X), By connecting a photo-coupler to close the control loop and achieve the regulation.
3	CS	Current sense pin, connect to sense the MOSFET current
4	GND	Ground
5	OUT	Gate drive output to drive the external MOSFET
6	VCC	Supply voltage pin
7	NC	Unconnected Pin
8	HV	Connect this pin to positive of bulk capacitor to provide the startup current for the controller, when Vcc voltage trips the UVLO(on), this HV loop will be off to save the power loss on the startup circuit.

Block Diagram

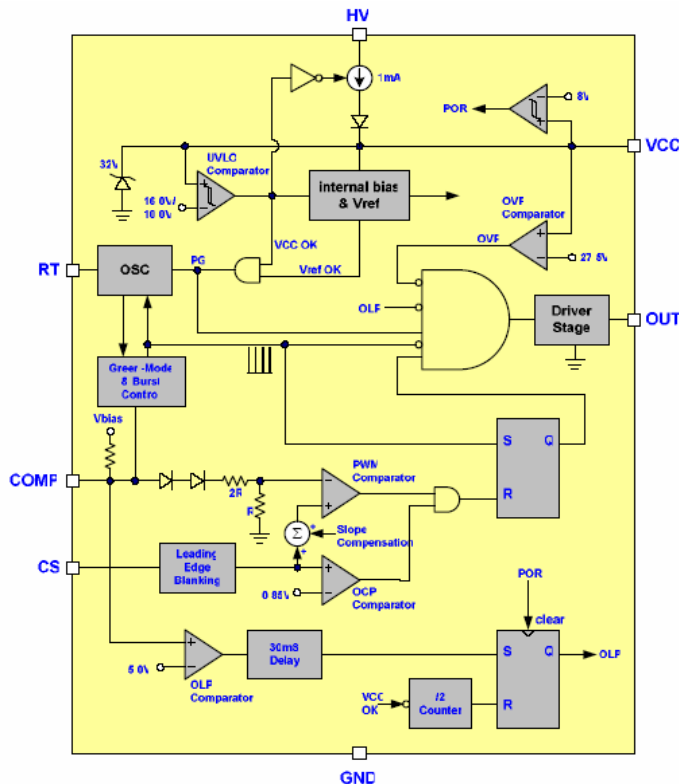

OZ9938GN(IC801): The OZ9938 is high performance, cost-effective CCFL controller designed for driving large-size LCD applications requiring 2 to 6 CCFLs. PWM control, Has such functions as short-voltage protection, Over-voltage protection, over-current protection and etc. The function of each pin and the circuit diagram inside are as follows:

PIN Descriptions:

Pin	Names	Description
1	DRV1	Drive output
2	VDDA	Supply voltage input
3	TIMER	Timing capacitor to set striking time and shutdown delay time
4	DIM	Analog dimming or Internal LPWM dimming or external PWM pulse input for dimming function
5	ISEN	Current sense feedback
6	VSEN	Voltage sense feedback
7	OVPT	Over-voltage/ over-current protection threshold setting pin
8	NC	No connection
9	NC	No connection
10	ENA	ON/OFF control of IC
11	LCT	Timing capacitor to set internal PWM dimming frequency and also a pin for analog dimming selection
12	SSECMP	Capacitor for soft start time and loop compensation
13	CT	Timing resistor and capacitor for operation and striking frequency
14	GNDA	Ground for analog signals
15	DRV2	Drive output
16	PGND	Ground for power paths

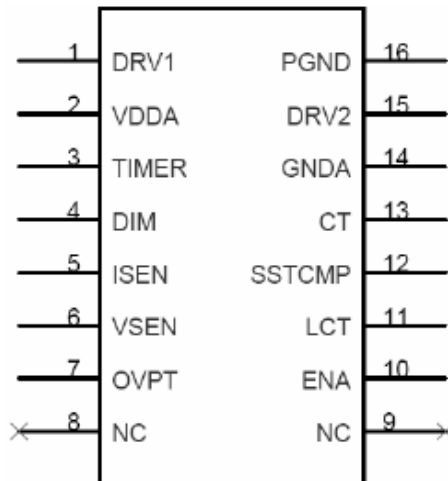

Block Diagram

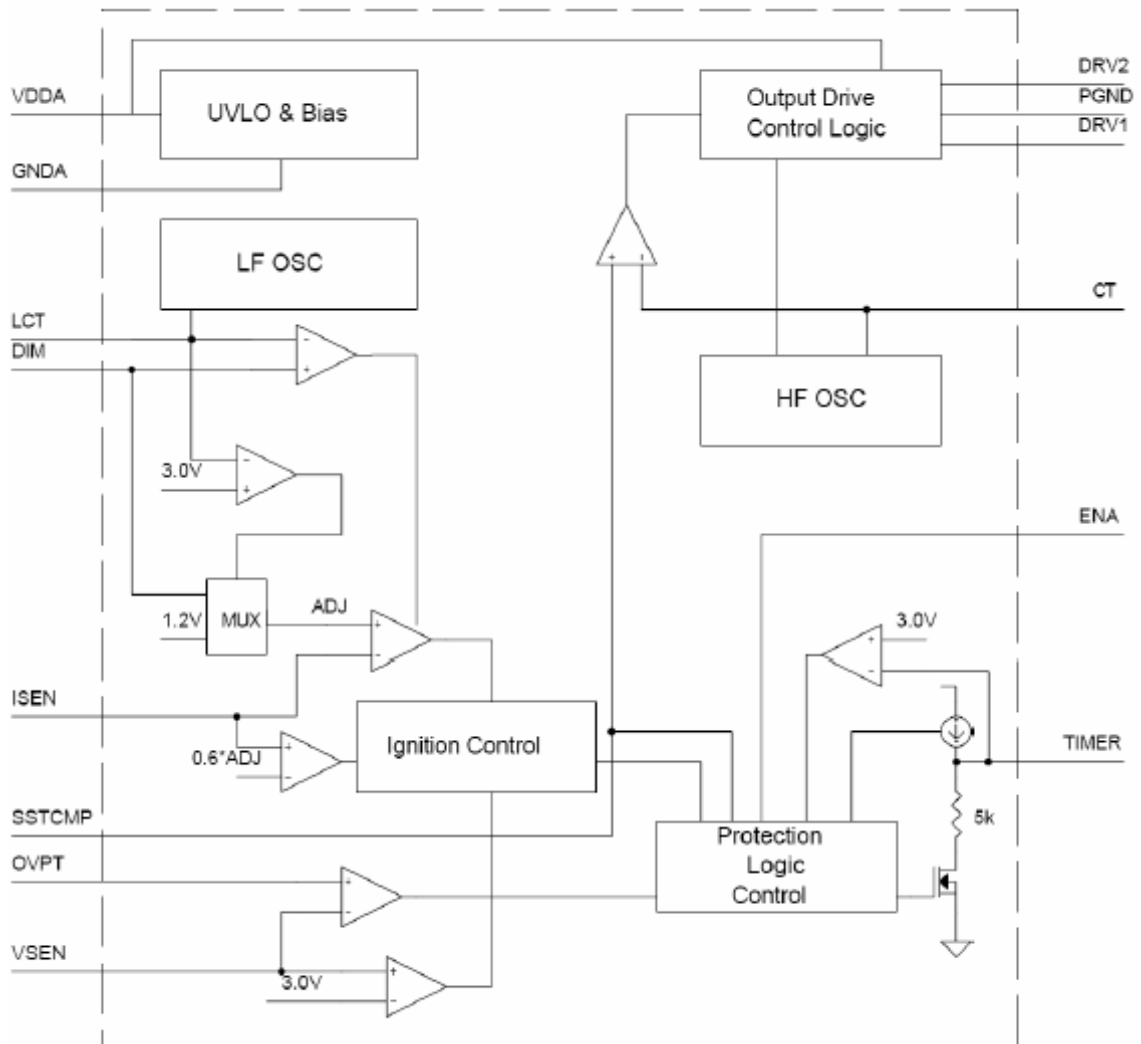

5. Adjustment Procedure

5.1 ADJUSTMENT CONDITIONS AND PRECAUTIONS

1. Approximately 30 minutes should be allowed for warm up before proceeding.
2. Adjustments should be undertaken only on those necessary elements since most of them have been carefully preset at the factory.
3. ESD protection is needed before adjustment.

5.2 MAIN ADJUSTMENTS

NO.	FUNCTIONS	DESIGNATION
1.	White Balance	Function Key
2.	Geometry	Function Key

5.3 ALIGNMENT PROCEDURES

Approximately 30 minutes should be allowed for warm up before proceeding White-Balance adjustment.

1. Adjust of White Balance

1.)How to do the Chroma-7120 MEM .Channel setting

- A、 Reference to chroma 7120 user guide
- B、 Use “**SC**” key and “**NEXT**” key to modify xyY value and use “**ID**” key to modify the TEXT description Following is the procedure to do white-balance adjust

2.)Setting the color temp. You want

- A、 MEM.CHANNEL9 (9300 color):
9300 color temp. parameter is $W_x = 0.283 \pm 0.03$; $W_y = 0.298 \pm 0.03$;
 $Y = 250 \pm 20 \text{ cd/m}^2$.
- B、 MEM.CHANNEL10 (6500 color):
6500 color temp. parameter is $W_x = 0.313 \pm 0.03$; $W_y = 0.329 \pm 0.03$;
 $Y = 260 \pm 20 \text{ cd/m}^2$.
- C、 MEM.CHANNEL 11 (5400 color):
5400 color temp. parameter is $W_x = 0.335 \pm 0.03$; $W_y = 0.350 \pm 0.03$;
 $Y = 250 \pm 20 \text{ cd/m}^2$.
- D、 MEM.CHANNEL10 (SRGB color):
6500 color temp. parameter is $W_x = 0.313 \pm 0.03$; $W_y = 0.329 \pm 0.03$;
 $Y = 220 \pm 20 \text{ cd/m}^2$.

3.)Into factory mode of VA503b/VA503m

- A、 First Power off, then press Switch 2 button along with press Power button will activate the factory mode, then MCU will do AUTO LEVEL automatically. Meanwhile press MENU the OSD screen will located at **LEFT TOP OF PANEL**.

4.)Bias adjustment :

Set the **Contrast**  to 70

Adjust the **Brightness**  to 100.

5.)Gain adjustment :

Move cursor to “-F-” and press MENU key

A、 Adjust 9300 color-temperature

- (1)、 Switch the Chroma-7120 to **RGB-Mode** (with press “MODE” button)
- (2)、 Switch the MEM. channel to Channel 9 (with up or down arrow on chroma 7120)
- (3)、 The LCD-indicator on chroma 7120 will show $x = 0.283 \pm 0.03$, $y = 0.298 \pm 0.03$,
 $Y = 250 \pm 20 \text{ cd/m}^2$
- (4)、 Adjust the RED of color1 on factory window until chroma 7120 indicator reached the value $R=100$
- (5)、 Adjust the GREEN of color1 on factory window until chroma 7120 indicator reached the value $G=100$
- (6)、 Adjust the BLUE of color1 on factory window until chroma 7120 indicator reached the value $B=100$
- (7)、 Repeat above procedure (item 4,5,6) until chroma 7120 RGB value meet the tolerance $=100 \pm 5$

B、 Adjust 6500 color-temperature

- (1)、 Switch the chroma-7120 to **RGB-Mode** (with press “MODE” button)
- (2)、 Switch the MEM .channel to Channel 10(with up or down arrow on chroma 7120)
- (3)、 The LCD-indicator on chroma 7120 will show $x = 0.313 \pm 0.03$, $y = 0.329 \pm 0.03$, $Y = 260 \pm 20 \text{ cd/m}^2$
- (4)、 Adjust the RED of color3 on factory window until chroma 7120 indicator reached the value $R=100$
- (5)、 Adjust the GREEN of color3 on factory window until chroma 7120 indicator reached the value $G=100$
- (6)、 Adjust the BLUE of color3 on factory window until chroma 7120 indicator reached the value $B=100$
- (7)、 Repeat above procedure (item 4,5,6) until chroma 7120 RGB value meet the tolerance $=100 \pm 5$

C、 Adjust 5400 color-temperature

- (1) Switch the chroma-7120 to **RGB-Mode** (with press “MODE” button)
- (2)、 Switch the MEM .channel to Channel 11(with up or down arrow on chroma 7120)
- (3)、 The LCD-indicator on chroma 7120 will show $x = 0.335 \pm 0.03$, $y = 0.350 \pm 0.03$, $Y = 250 \pm 20 \text{ cd/m}^2$
- (4)、 Adjust the RED of color3 on factory window until chroma 7120 indicator reached the value $R=100$
- (5)、 Adjust the GREEN of color3 on factory window until chroma 7120 indicator reached the value $G=100$
- (6)、 Adjust the BLUE of color3 on factory window until chroma 7120 indicator reached the value $B=100$
- (7)、 Repeat above procedure (item 4,5,6) until chroma 7120 RGB value meet the tolerance $=100 \pm 5$

D、 Adjust SRGB color-temperature

- (1)、 Switch the chroma-7120 to **RGB-Mode** (with press “MODE” button)
- (2)、 Switch the MEM .channel to Channel 10(with up or down arrow on chroma 7120)
- (3)、 The LCD-indicator on chroma 7120 will show $x = 0.313 \pm 0.03$, $y = 0.329 \pm 0.03$, $Y = 220 \pm 20 \text{ cd/m}^2$
- (4)、 Adjust the RED of color3 on factory window until chroma 7120 indicator reached the value $R=100$
- (5)、 Adjust the GREEN of color3 on factory window until chroma 7120 indicator reached the value $G=100$
- (6)、 Adjust the BLUE of color3 on factory window until chroma 7120 indicator reached the value $B=100$
- (7)、 Repeat above procedure (item 4,5,6) until chroma 7120 RGB value meet the tolerance $=100 \pm 5$

E、 Press reset key and Turn the Power-button “off to on” to quit from factory mode.

2. Geometry

- 1).Set cross-hatch pattern and preset timing as timing table listed.
- 2).Change to each mode in turn and wait for the monitor finish auto-alignment and save press before change to next mode.
- 3).Until all of modes are adjusted,exit OSD menu and press POWER OFF to exit factory mode.

5.4 Factory Defaults

Item	Defaults	Item	Defaults
Contrast	70%	Volume	50% (For VA703m only)
Brightness	100%	Balance	N/A
Color Temperature	6500K	Treble	N/A
Sharpness	0%	Bass	N/A
OSD H. Position	50%	720x400/640x400	720x400
OSD V. Position	50%	640x480@60Hz 720x480@60Hz	640x480@60Hz
OSD Time Out	15 Sec	In SOG and Composite, 720x480@60Hz 640x480@60Hz	N/A
OSD Background	Enabled	In SOG and Composite, 1152x864@75Hz 1152x870@75Hz	N/A
Resolution Notice	Enabled	In SOG and Composite, 1280x768@60/75/85Hz 1024x768@60/75/85Hz	N/A

5.5 Function Test

- 1 Product: 17" LCD Monitor
- 2 Test Equipment: Color Video Signal & Pattern (or PC with SXGA resolution and a sound card)
- 3 Test Condition: Before function test and alignment, each LCD Monitor should be warmed up for at least 30 minutes with the following conditions:
 - (a) In room temperature,
 - (b) With full-white screen, RGB, and Black
 - (c) With cycled display modes,
640*480 (H=43.27kHz, V=85Hz)
800*600 (H=53.7kHz, V=85Hz)
1024*768 (H=68.67kHz, V=85Hz)
1280*1024 (H=79.97kHz, V=75Hz)

4 Test Display Modes & Pattern

Compatible Modes

Item	Timing	Analog
1	640 x 350 @ 70Hz, 31.5kHz	Yes
2	640 x 480 @ 50Hz	Yes
3	640 x 480 @ 60Hz, 31.5kHz	Yes
4	640 x 480 @ 67Hz, 35.0kHz	Yes
5	640 x 480 @ 72Hz, 37.9kHz	Yes
6	640 x 480 @ 75Hz, 37.5kHz	Yes
7	640 x 480 @ 85Hz, 43.27kHz	Yes
8	720 x 400 @ 70Hz, 31.5kHz	Yes
9	800 x 600 @ 56Hz, 35.1kHz	Yes

10	800 x 600 @ 60Hz, 37.9kHz	Yes
11	800 x 600 @ 72Hz, 48.1kHz	Yes
12	800 x 600 @ 75Hz, 46.9kHz	Yes
13	800 x 600 @ 85Hz, 53.7kHz	Yes
14	832 x 624 @ 75Hz, 49.7kHz	Yes
15	1024 x 768 @ 60Hz, 48.4kHz	Yes
16	1024 x 768 @ 70Hz, 56.5kHz	Yes
17	1024 x 768 @ 72Hz, 58.1kHz	Yes
18	1024 x 768 @ 75Hz, 60.0kHz	Yes
19	1024 x 768 @ 85Hz	Yes
20	1152 x 864 @ 75Hz	Yes
21	1152 x 870 @ 75Hz	Yes
22	1280 x 720 @ 60Hz	Yes
23	1280 x 960 @ 60Hz	Yes
24	1280 x 960 @75Hz	Yes
25	1280 x 1024 @ 60Hz	Yes
26	1280 x 1024 @ 75Hz	Yes

Function Test Display Pattern

Item	Test Content	Pattern	Specification	Remark
1	Frequency & Tracking	Fine Line Moire	Eliminate visual wavy noise.	Figure 1
2	Contrast/Brightness	16 Gray Scale	16 gray levels sh should be distinguishable.	Figure 2
3	Boundary	Horizontal&Vertical Thickness	Horizontal and Vertical position of video should be adjustable to be within the screen frame.	Figure 3
4	RGB Color Performance	RGB Color Intensities	Contrast of each R, G, B, color should be normal.	Figure 4,5,6
5	Screen Uniformity & Flicker	Full White	Should be compliant with the spec.	Figure 7
6	Dead Pixel/Line	White Screen & Dark Screen	The numbers of dead pixels should be compliant with the spec.	Figure 7,8
7	White Balance	White & Black Pattern	The screen must have the pure white and black pattern, no other color.	Figure 9



Fine Line Morie Pattern (Figure 1)

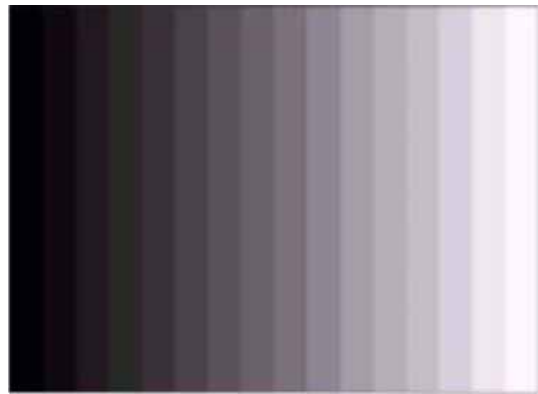

Gray Scale Pattern (Figure 2)



Horizontal & Vertical Thickness Pattern (Figure 3)



R. Color Pattern (Figure 4)



G. Color Pattern (Figure 5)



B. Color Pattern (Figure 6)



Full White Pattern (Figure 7)



Dark Screen Pattern (Figure 8)

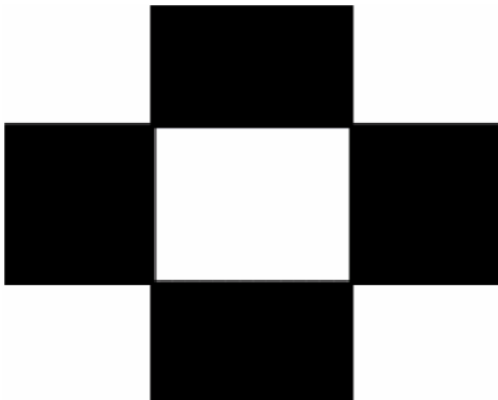

Black-White Pattern (Figure 9)

4.3 Function Test and Alignment Procedure

All Modes Reset

You should do “All Mode Reset” (Refer to Chapter III-3. Hot Keys for Function Controls) first. This action will allow you to erase all end-user’s settings and restore the factory defaults.

Auto Image Adjust

Please select and enter “Auto Image Adjust” function on Main Menu to see if it is workable. The “Auto Image Adjust” function is aimed to offer a better screen quality by built-in ASIC. For optimum screen quality, the user has to adjust each function manually.

Firmware

Test Pattern: Burn In Mode (Refer to Chapter III-3. Hot Keys for Function Controls)

- Make sure the F/W is the latest version.

DDC

Test Pattern: EDID program

Make sure it can pass test program.

Fine Tune and Sharpness

Test Signal: 1280*1024@60Hz

Test Pattern: Line Moire Pattern

Check and see if the image has noise and focus performs well. Eliminate visual

line bar.

If not, readjust by the following steps:

(a) Select and enter "Fine Tune" function on "Manual Image Adjust" to adjust the image to eliminate visual wavy noise.

(b) Then, select and enter "Sharpness" function to adjust the clarity and focus of the screen image.

Boundary

Test Signal: 1280*1024@60Hz

Test Pattern: Horizontal & Vertical Line Thickness Pattern

Check and see if the image boundary is within the screen frame.

If not, readjust by the following steps:

(a) Select and enter "Manual Image Adjust" function on OSD Main Menu.

(b) Then, select and enter "Horizontal Size" or "Horizontal/Vertical Position" function to adjust the video boundary to be full scanned and within screen frame.

White Balance

Test Signal: 640*480@60Hz

Test Pattern: White and Black Pattern

1.5.8 R, G, B, Colors Contrast

Test Signal: 1280*1024@60Hz

Test Pattern: R, G, B, Color Intensities Pattern and 16 Gray Scale Pattern

- Check and see if each color is normal and distinguishable.
- If not, please return the unit to repair area.

Screen Uniformity and Flicker

Test Signal: 1280*1024@60Hz

Test Pattern: Full White Pattern

- Check and see if it is in normal condition.

1.5.10 Dead Pixel and Line

Test Signal: 1280*1024@60Hz

Test Pattern: Dark and White Screen Pattern

- Check and see if there are dead pixels on LCD panel with shadow gauge and filter film.
- The total numbers and distance of dead pixels should be compliant with the spec.

Mura

Test Pattern: White, RGB, Black, & Grey

Test Tool: 10% ND Filter

- Check if the Mura can pass 10% ND Filter.

Audio

Test Signal: Voice signal (optional, depend on model)

Test Pattern: liberty

- Make sure there is audio output.
- Make sure that audio function (volume 80%) is working without noise and resonance.
- Make sure that the sound of right and left speakers are in balance.

Check for Secondary Display Modes

Test Signal:

Analog: 640*350@70Hz; 640*480@60/67/72/75/85Hz;

720*400@70Hz; 800*600@56/60/72/75/85Hz;
832*624@75Hz, 1024*768@60/70/72/75/85Hz;
1280*1024@60/75Hz

- Normally when the primary mode 1280*1024@60Hz is well adjusted and compliant with the specification, the secondary display modes will also be compliant with the spec. But we still have to check with the general test pattern to make sure every secondary is compliant with the specification.

All Modes Reset

After final QC step, we have to erase all saved changes again and restore the factory defaults. You should do "All Mode Reset" again.

Power Off Monitor

Turn off the monitor by pressing "Power" button.

5.6 Firmware Upgrade Procedure

When you receive the returned monitor, please check whether the firmware version is the latest. If not, please do the following procedures to upgrade it to the latest version.

1 Equipment Needed

- VA503/VA703/VA903 Monitor
- Fixture for Firmware Upgrade
- Power Adapter (P/N: 47.58201.001) *1 for Fixture
- VGA Cable (P/N: 42.59901.003) *1(Pin 4, 11 should be connected to GND)
- PC (Personal Computer)
- LPT Cable (P/N: 42.59906.001) *1
- Firmware Upgrade Program
- One additional monitor for checking the program execution



PC



Fixture



VA703b / VA703m



Power Adapter for Fixture
(P/N: 47.58201.001)



LPT Cable
(P/N: 42.59906.001)



VGA Cable
(P/N: 42.59901.003)

2 Setup Procedure

- 2.1 Connect P2 of Fixture with printer port of PC by LPT Cable.
- 2.2 Connect P1 of Fixture with VA503/VA703/VA903 Monitor by VGA Cable.
- 2.3 Plug Power Adapter to Fixture.
- 2.4 Connect Power Cord to VA503/VA703/VA903 Monitor.
- 2.5 Connect P3 to the Signal Generator (eg.Chroma2326) for verifying it after the operation being completed.
- 2.6 Connect PC to the additional monitor.

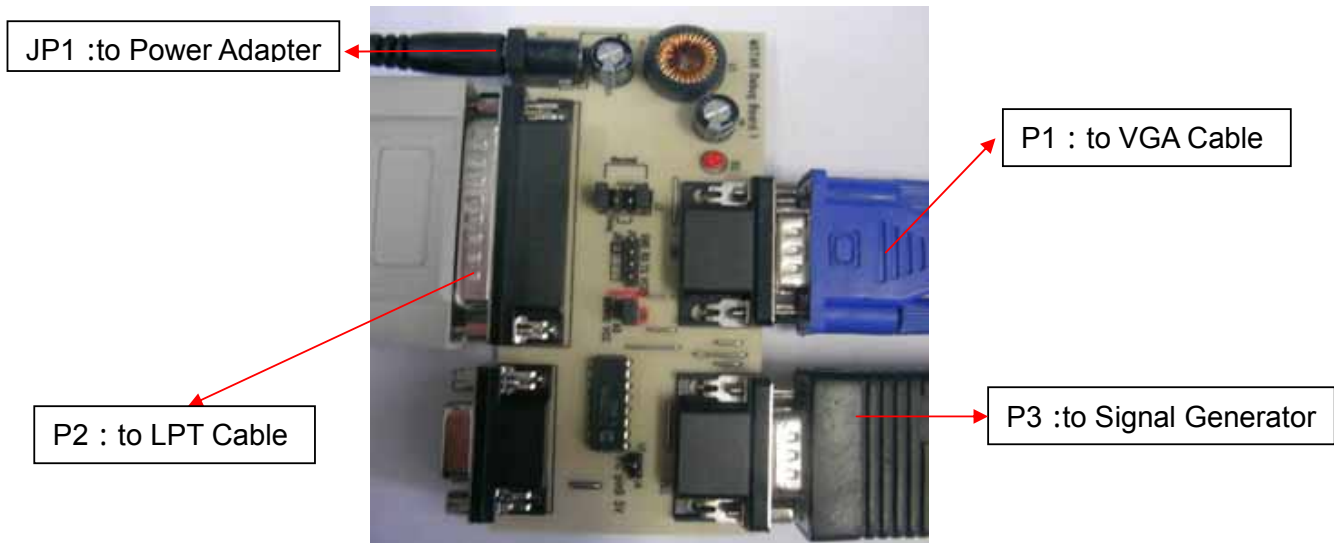

3 Firmware Upgrade Procedure

Step 1. Let VA503/VA703/VA903 set to be connected with AC cable and VGA cable.

Step 2. Execute the MSstar ISP tool.



Step 3. Click “Config” button . Select the Port Type: LPT1 and the Base Addr : 0x378 on “Communication Setting” flame, and then the Speed: 47 on “E2PROM Device Setting” flame

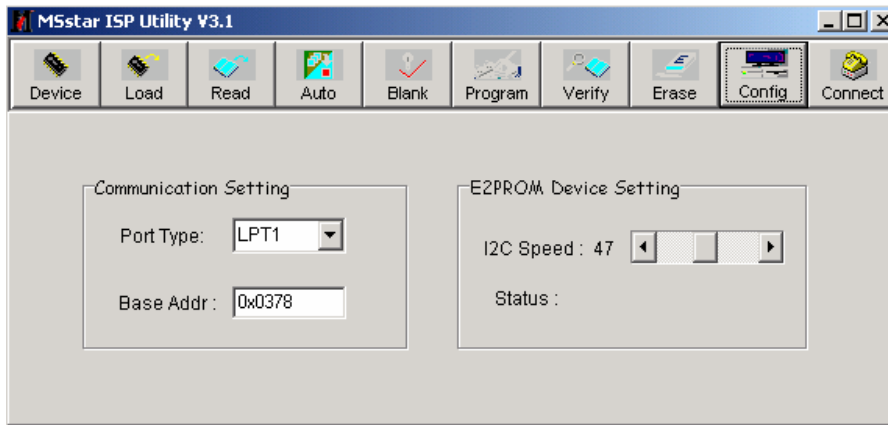

Step 4. Click “Connect” button. (On this step, if the connection is successful, the “Entry ISP Mode” Dialog will be showed. If not, the error dialog will be done.)



Step 5. Click “Device” button. Select the “PMC25LV010” or “SST25VF010” viewed on your set.

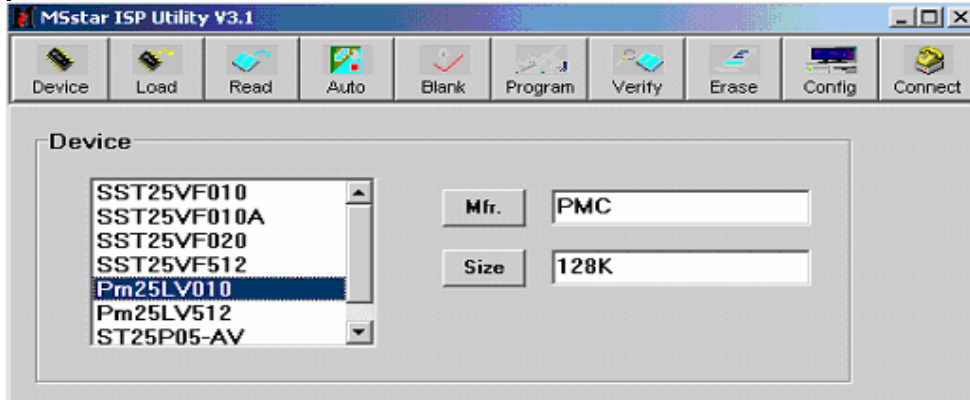

Step 6. Click “Read” button. Select the object bincode on your corresponding directory.

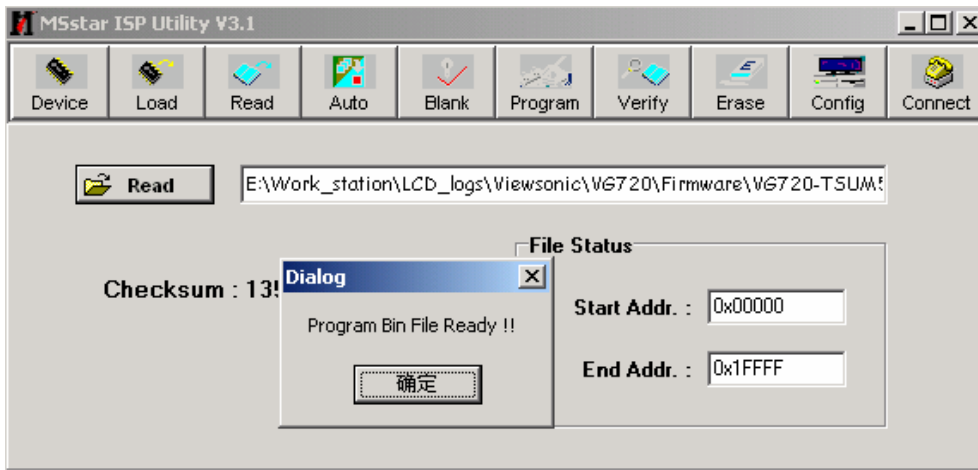

Step 7. Click “Auto” button. Execute the flashing action by clicking the “Run” button.

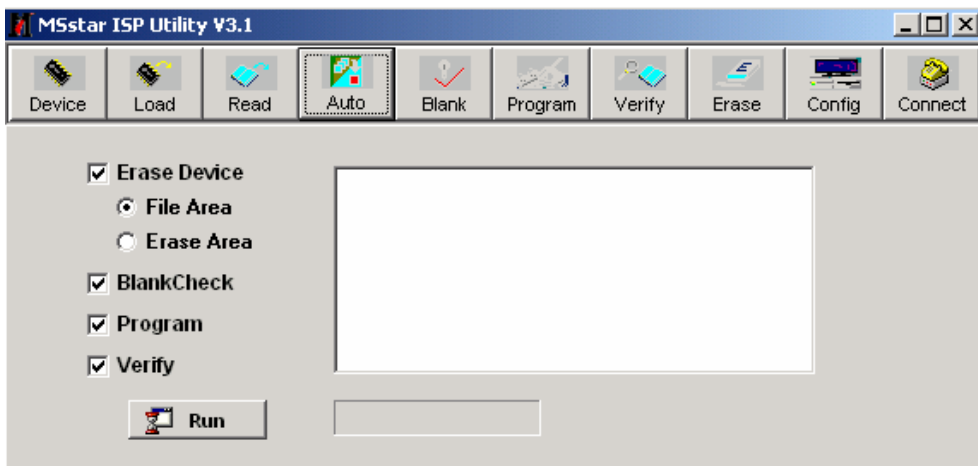

Step 8. If the flashing F/W has been completed, "Ok" message will be showed on the right TextBox.

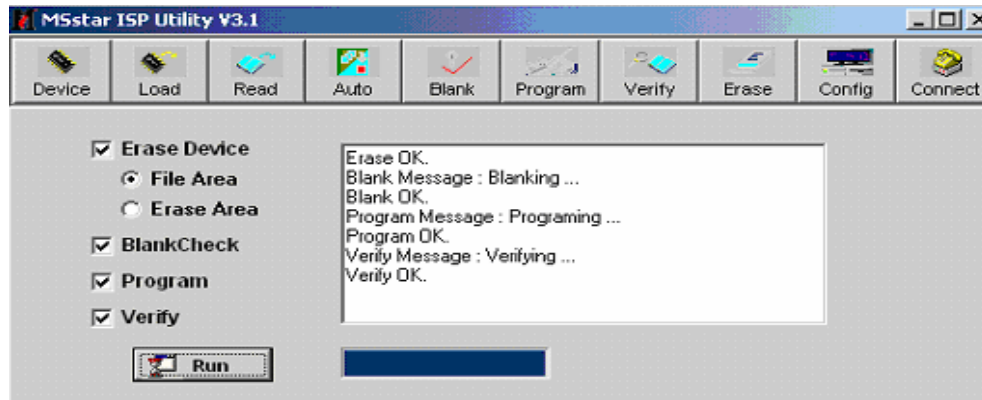

Step 9. Unplug and replug power cord of VA503/VA703/VA903 set and then check the OSD operation and image on screen.

Step 10. At last, do "Memory Recall."

3.2 Setup Procedure

3.2.1 Connect P2 and monitor of Fixture with VGA ports of VA503/VA703/VA903 by VGA Cable.

3.2.2 Connect P1 of Fixture with [Printer port](#) of PC by LPT Cable.

3.2.3 Plug Power Adapter to Fixture.

3.2.4 Connect Power Cord to VA503/VA703/VA903 Monitor.

3.2.5 Connect PC to the additional monitor.

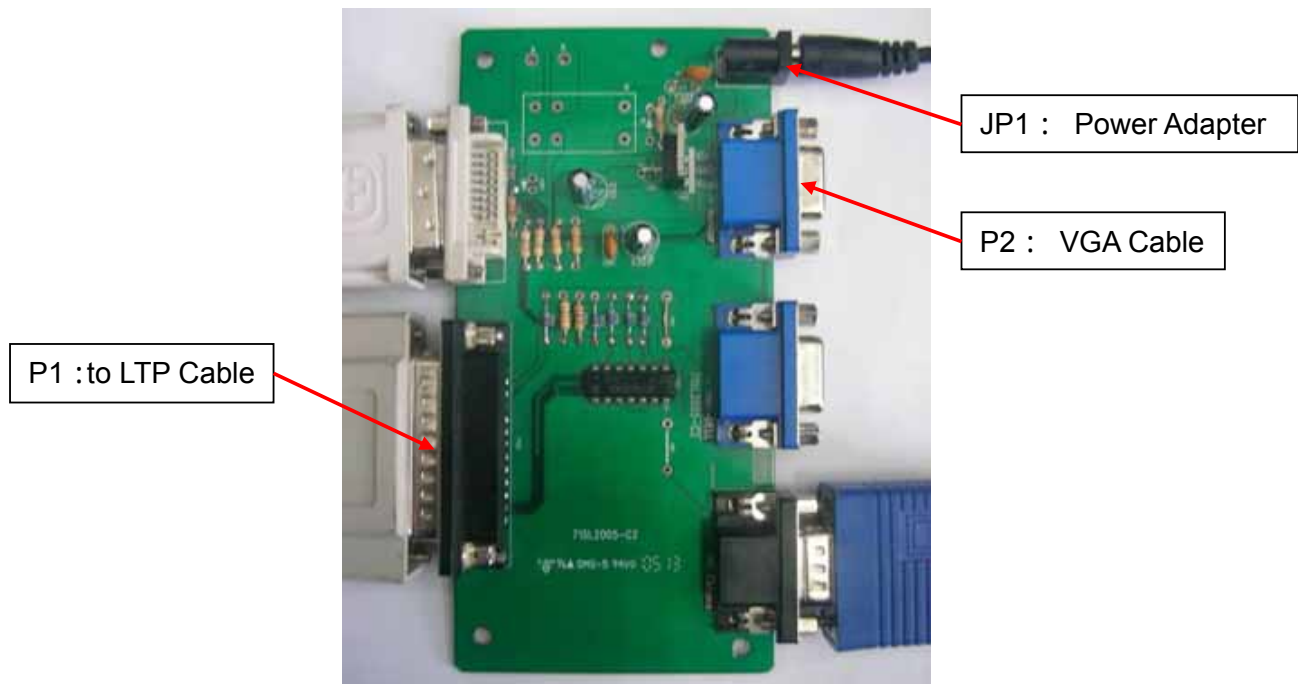

3.3 DDC Key In Procedure

Sep1.Select and execute DDC Key In program

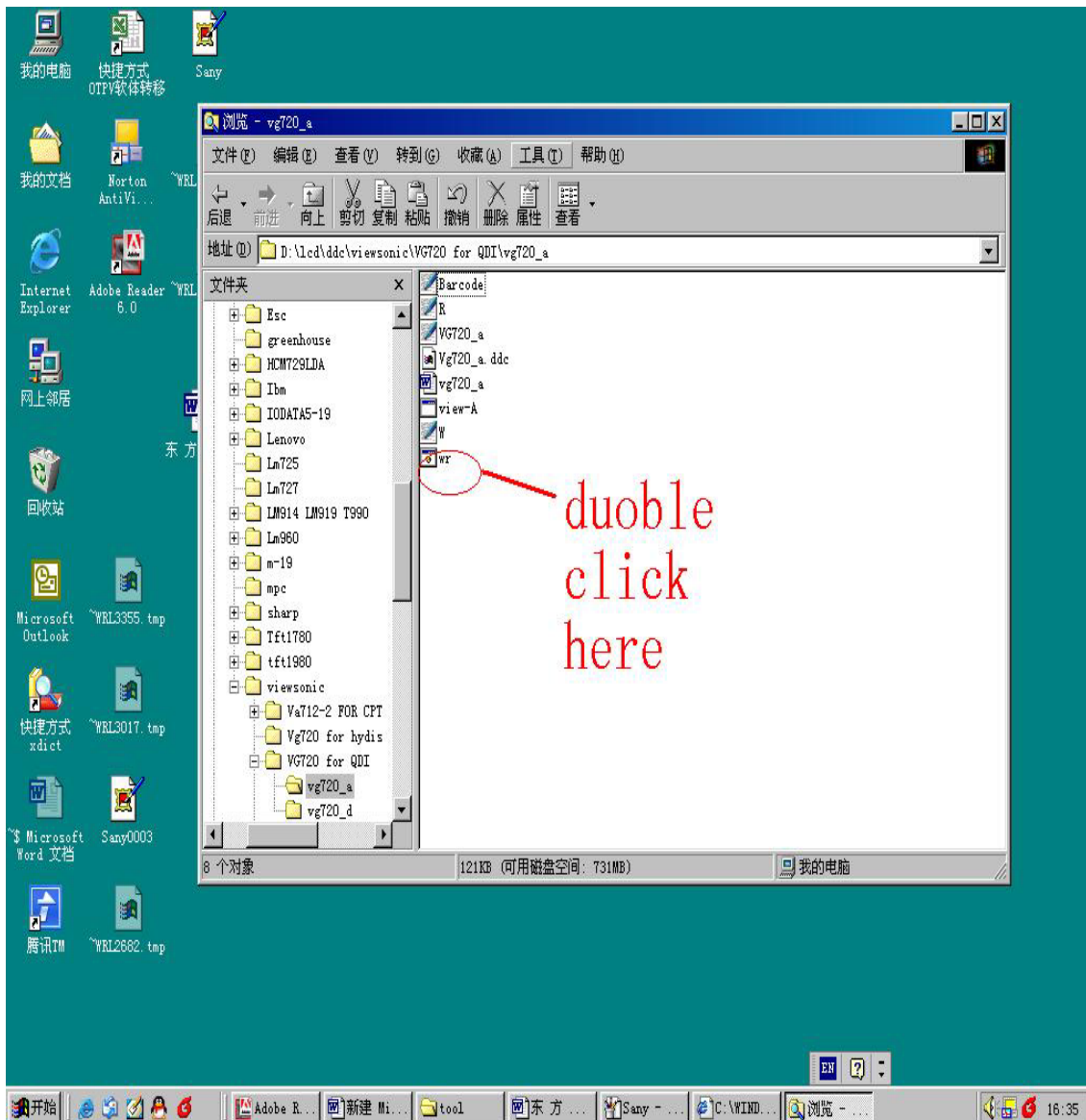

Sep2:Inpute the S/N and execute "Enter"

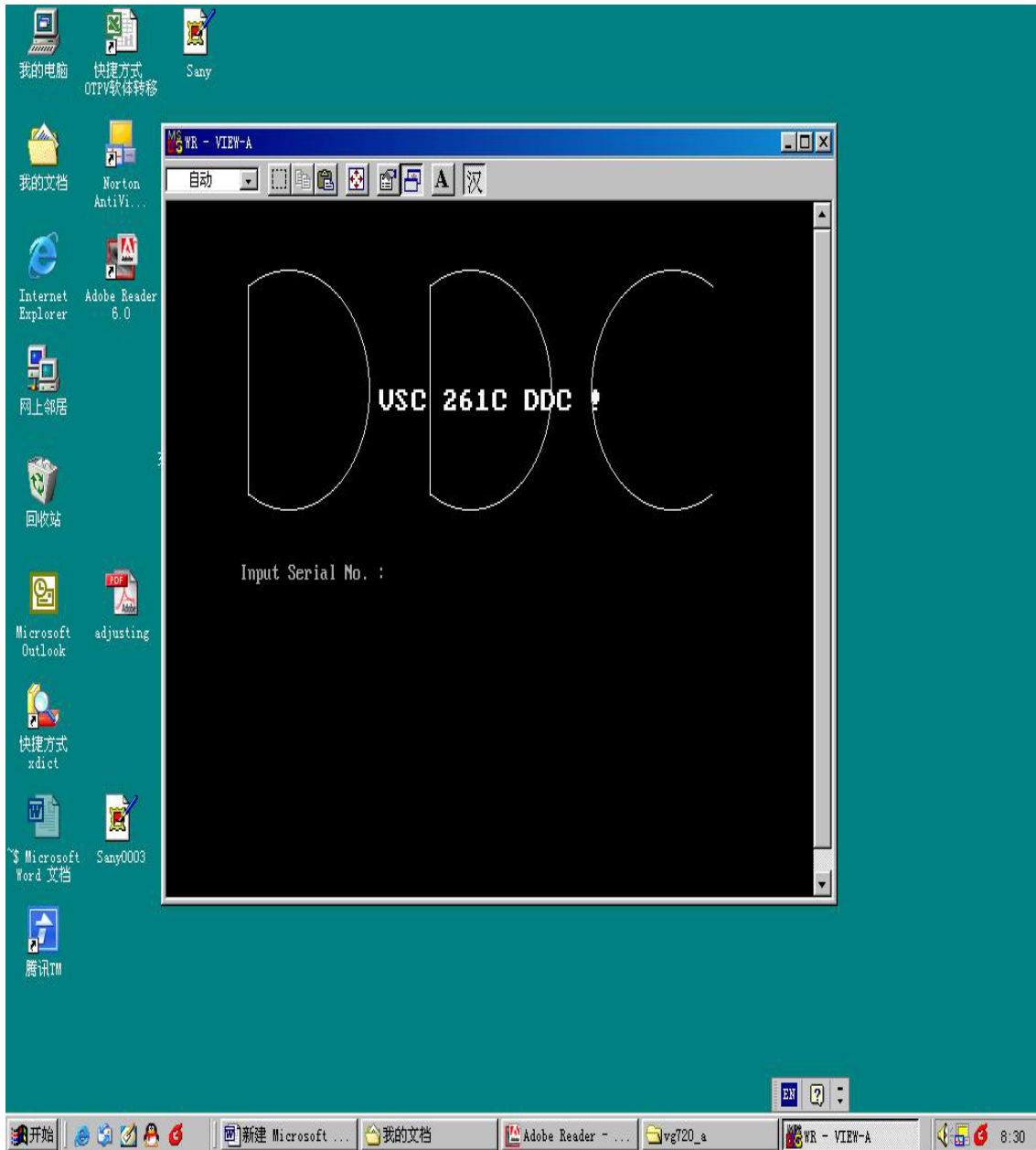

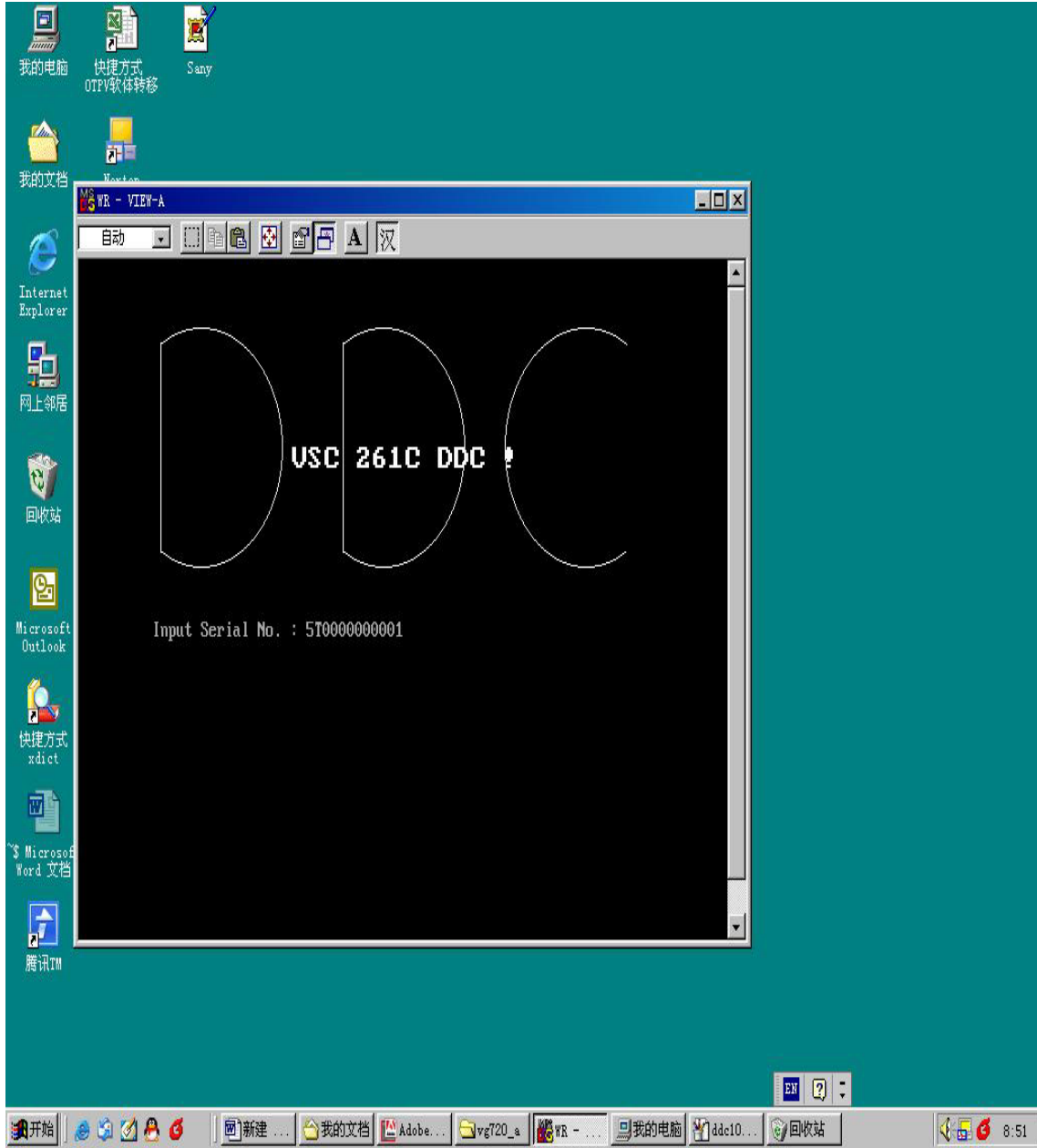

Sep3:Key the “Enter” and write the data

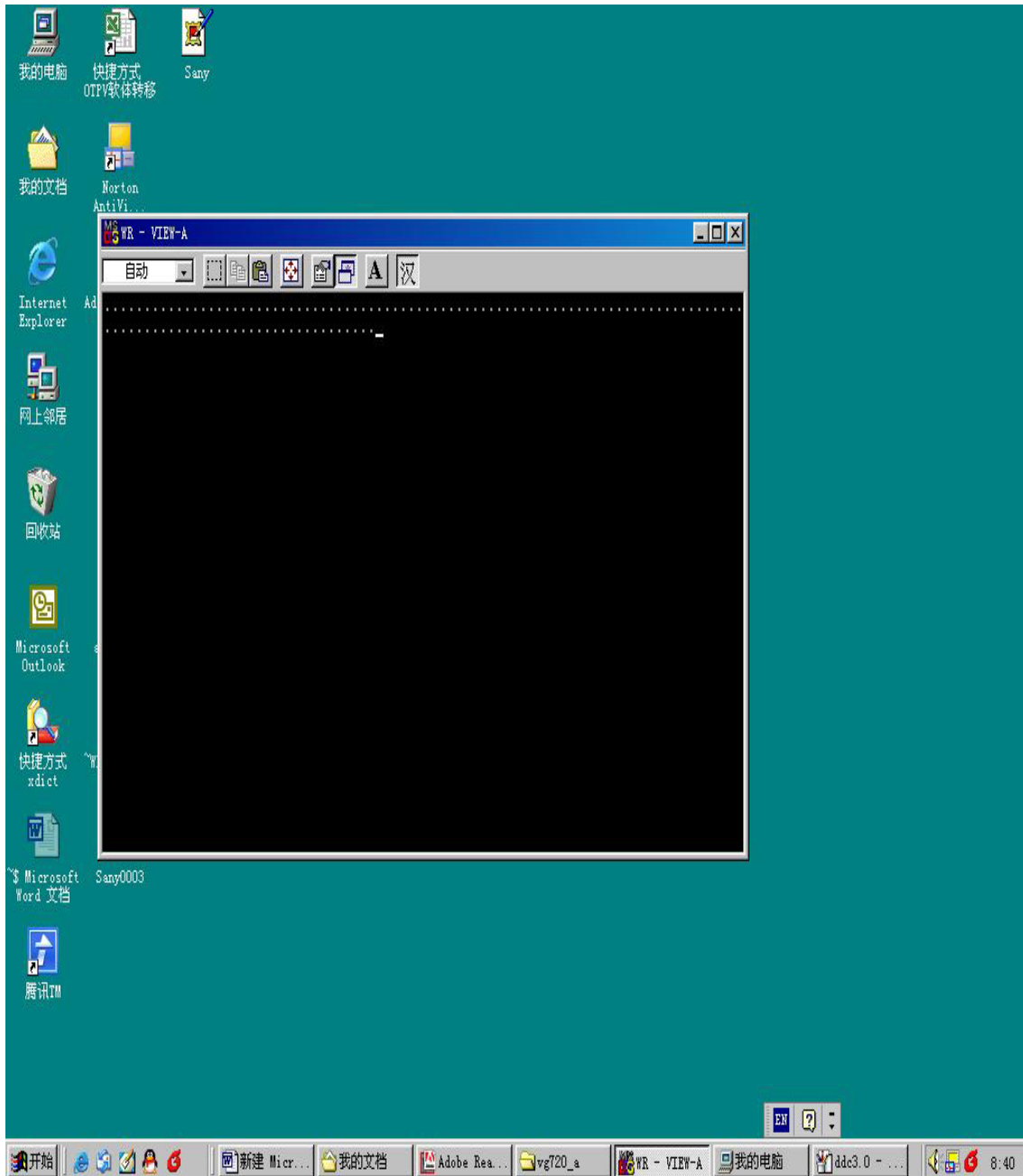

Sep4:If ddc program OK and show "data compare ok"

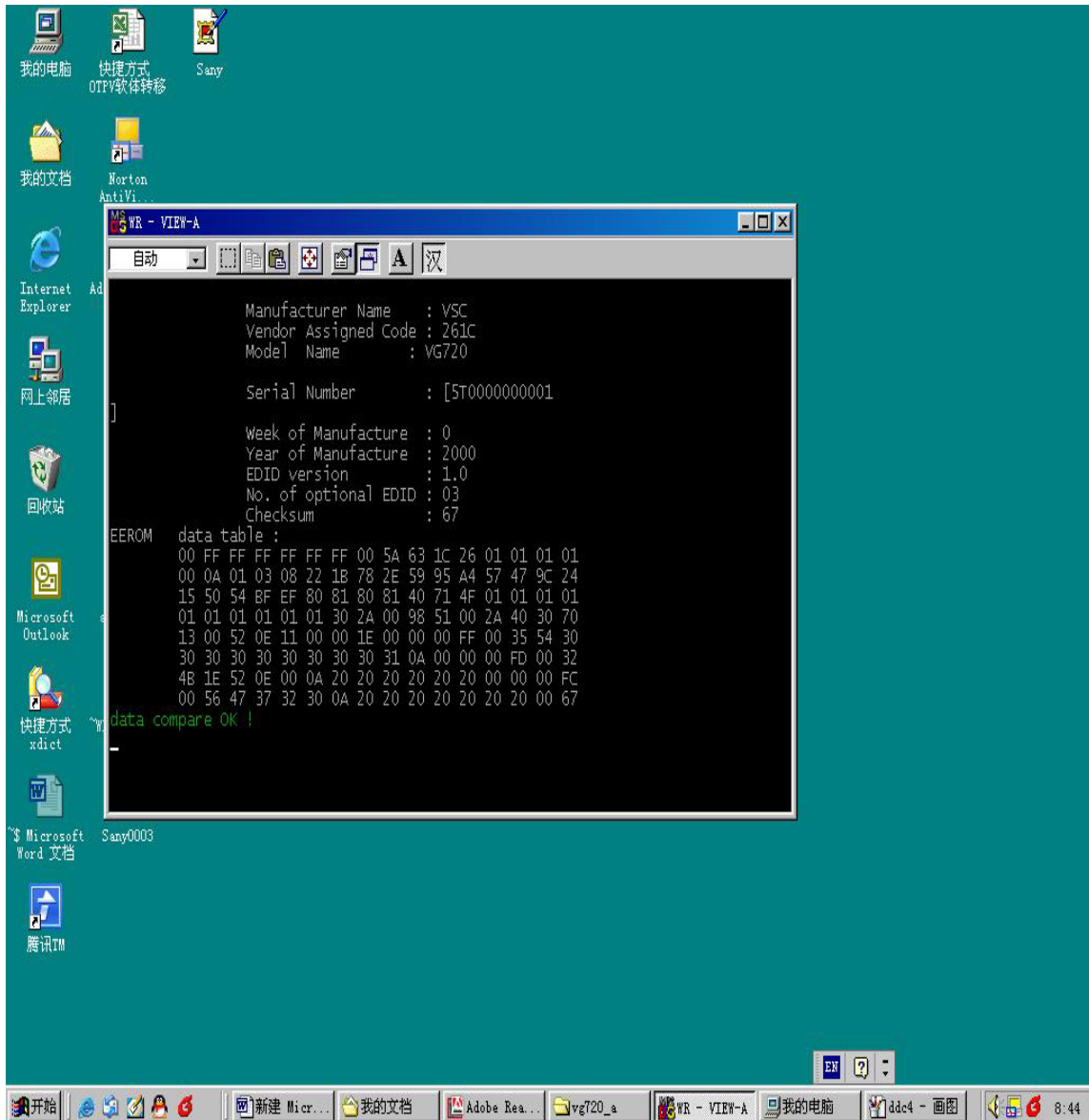

5.7 Packing Procedure

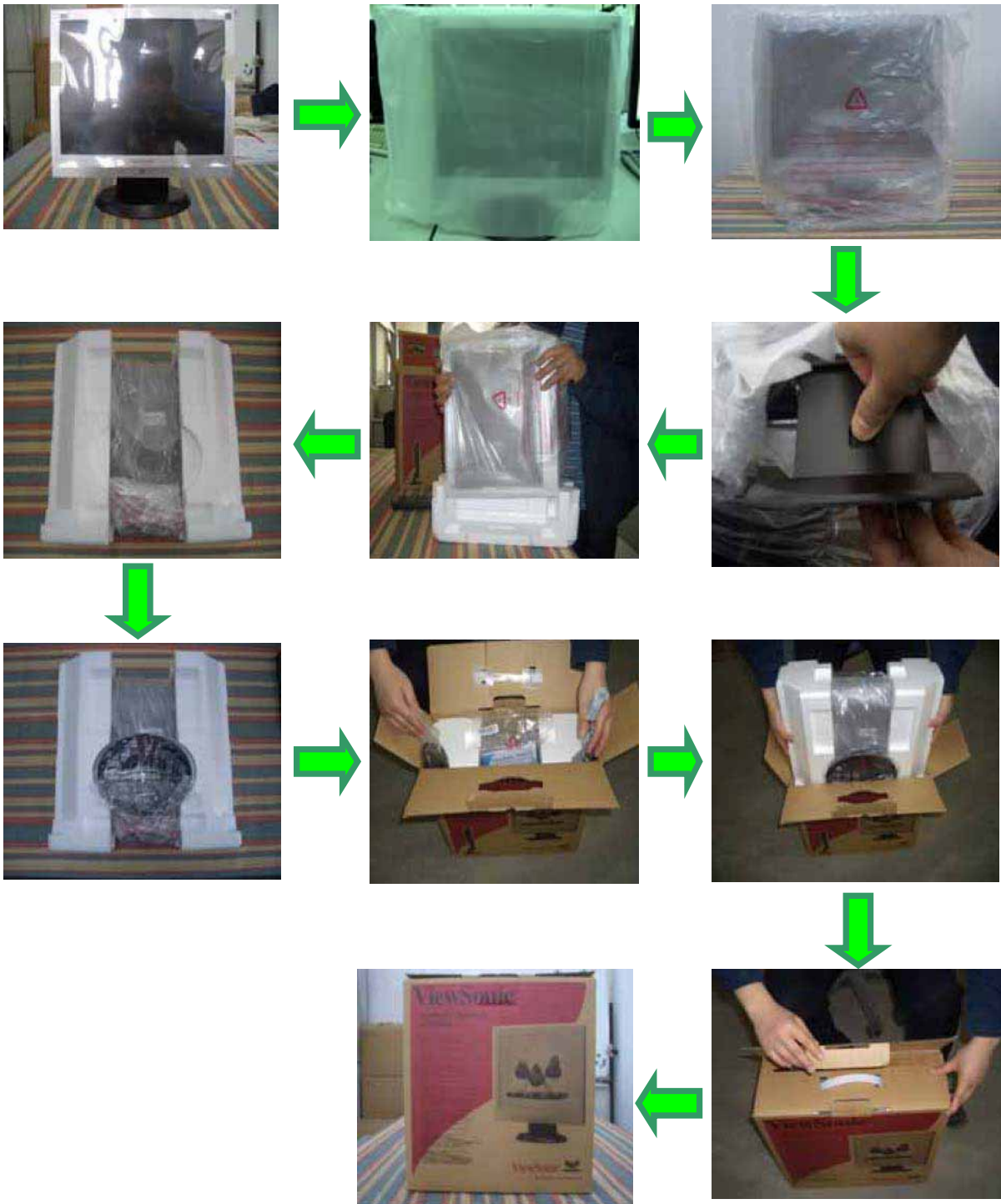

6. Troubleshooting Flow Chart

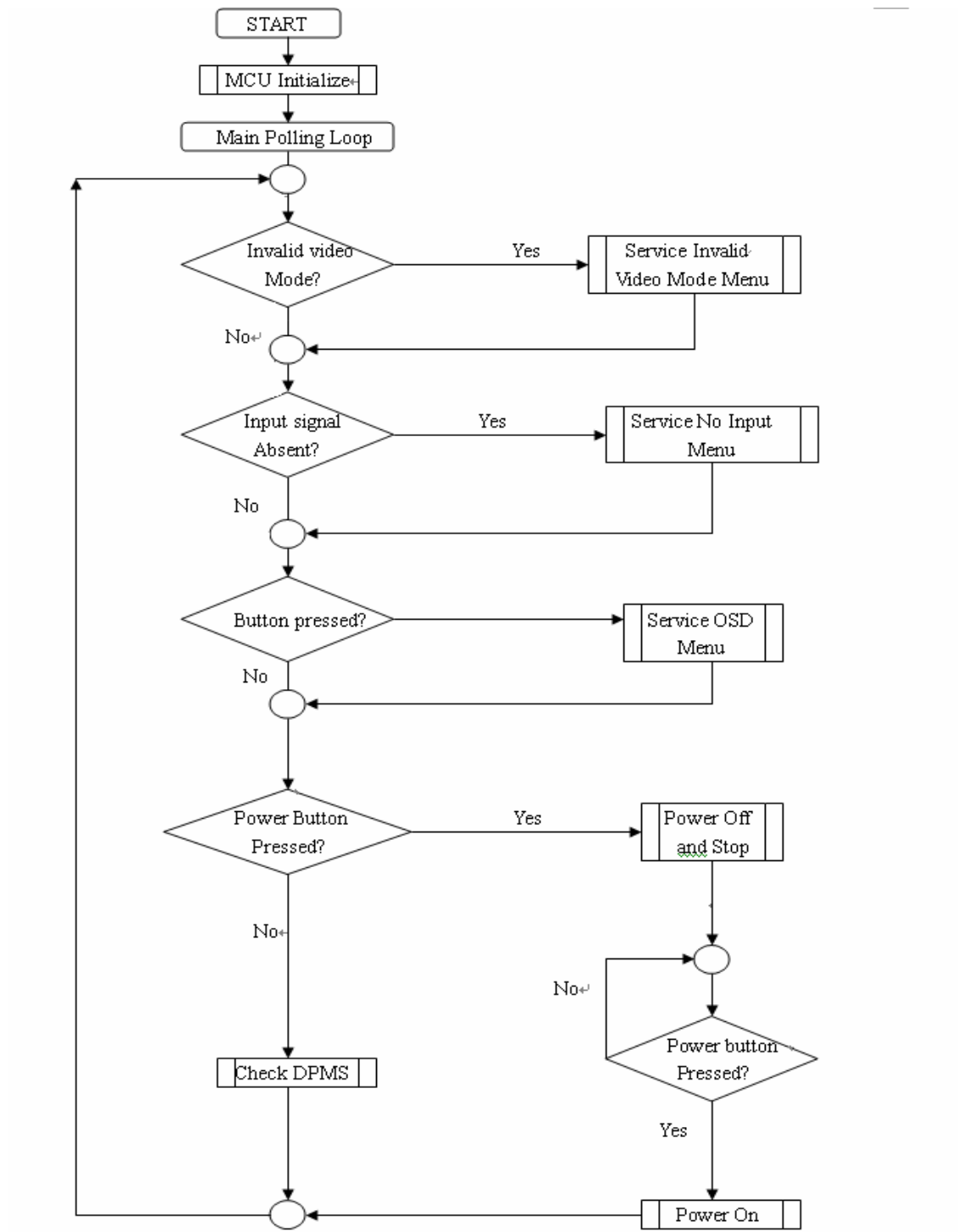

7. Recommended Spare Part List

VA703m BOM list—T780KK5HKUVWABP

Item	ViewSonic P/N	Ref. P/N	Description	Location	Universal number#	Q'ty
1		AUPC780B4P	AUDIO BOARD			1
2		CBPC780KK5VWAP	CONVERSION BOARD			1
3		KEPC560KD9P	KEPC BOARD			1
4		PWPC1742HDV3P	POWER BOARD			1
5		19G6014 2	塑料打包固定夹			0.2
6		23G3178709 4A	VSC17-LCD FRONT LOGO			1
7		23G3178709 6A	BIRD LOGO (E015-006)			1
8		33G5019 KD C	FUNC.BUTTON			1
9		37G 561 1	HINGE			1
10		40G 45760819A	机种标签			1
11		40G 459709 1B	CARTON LABEL			1
12		40G 459709 4A	H/V WARNING LABEL			1
13		40G 459709 5A	HI -POT LABEL FOR 17-LCD			1
14		40G 581 26704	唛头纸 FOR CARTON/PALLET			0
15		40G 58162435A	MANUAL P/N LABEL			1
16		40G457B709 1A	Hg LABEL			1
17		40G581B709 3A	8ms STICKER			1
18		40G581B709 4A	S/N LABEL			2
19		44G3231 12 A	EVA WASHER			1
20		44G9003194	CORNER PAPER			0.056
21		45G 76 28 V3	PE BAG			1
22		45G 77 3	TRANSPARENT SHEET			173
23		45G 88606	PE BAG FOR BASE			1
24		45G 88607	PE BAG			1
25		45G 88609 B	EPE COVER			1
26		50G 600 1 W	白色机用打包带			74
27		50G 600 2	HANDLE1			1
28		50G 600 3	HANDLE2			1
29		52G 1185	MIDDLE TAPE FOR CARTON			10
30		52G 1185 24	TAPE			65
31		52G 1207 A	铝箔胶带			1
32		52G 2191 D	美纹胶带			75
33		52G6020 1	PROTECT FILM			0.1
34		78G 455 3 K	SPEAKER,80HM 1.5W			2
35		78G 455 3 Y	SPEAKER,80HM 1.5W			0
36		89G 173 56 31	AUDIO CABLE			1

37		89G 725GAA903	SIGNAL CABLE			0
38		89G 725HAA903	SIGNAL CABLE			1
39		89G402A18N IS	POWER CABLE			0
40		89G402A18N LS	POWER CORD			1
41		95G8014 16702 X	KEY HARNESS			1
42		95G8018 30695	LVDS			1
43		M1G 130 5120	SCREW M3X5	XN01A		4
44		M1G 330 4120	SCREW	XN01A		4
45		M1G 330 6 47	SCREW	XN01A		4
46		M1G1140 6120	SCREW	XN01A		1
47		M1G1730 6120	M3*6	XN01A		2
48		M1G1730 6120	M3*6	XN01B		3
49		M1G1730 6120	M3*6	XN01C		4
50		M1G2640 8 47	M4*8	XN01A		4
51		Q1G 330 6120	SCREW M3X6MM	XN01A		3
52		Q1G1140 8120	SCREW	XN01A		3
53		750GLK70E1131N	HT170E01-101 17" LCD PAN			1
54		750GLK70E1141N	HT170E01-101 17" LCD PAN			0
55		A34G0025 KR 1L	REAR COVER PSWG/W AUDIO			1
56		A34G0026AKD L	BEZEL			1
57		A34G0027 KR L	STAND			1
58		A34G0028 KR L	BASE			1
59		A34G0029 KR L	HINGE COVER			1
60		J 7G 1 S 48	WOODEN PALLET			0.014
61		J12G 394800	FOOT			6
62		J12G 808 1	VESA RUBBER			4
63		J15G0013 1	VESA PLATE			2
64		J15G8312 1	MAIN FRAME HYDIS			1
65		J15G8313 1	AC SOCKET BRKT			1
66		J40G 581709 1A	栈板标签			0.25
67		J40G170T709 7A	ID VA703M			1
68		J40GSTAR709 1A	EPA LABEL			1
69		J41G7801709 8A	QSG			1
70		J44G6002 S 40	PAPER PLATE			0.014
71		J44G6002 S 41	PAPER PLATE			0.014
72		J44G6002709 1A	FILLING CARTON			0.06
73		J44G7003 1	EPS(L)			1
74		J44G7003 2	EPS(R)			1
75		J44G7003709 1A	CARTON			1

76		J52G8001 9	NON-WOVEN FABRICS			2
77		J52G8001 10	NON-WOVEN FABRICS			1
78		J70G170170912A	CD MANUAL			1
79		J85G 740 1 3	MAIN SHIELD			1
80		Q52G6025 11997	绝缘片			1
81		AUPC780B4P	AUDIO BOARD			
82		AUPC780B4SMTP	AUDIO BOARD			1
83		33G802414C H	WAFER	CN202		1
84		51G6002 1	导热胶			0.2
85		56G 616 1	AMPLIFIER IC E-TDA7496L	U201		1
86		67G215L471 3N	470UF/16V	C201		1
87		67G215L471 3N	470UF/16V	C202		1
88		67G215L471 3N	470UF/16V	C205		1
89		67G215L471 3N	470UF/16V	C207		1
90		67G215L471 3N	470UF/16V	C208		1
91		88G 30214K	PHONE JACK 5PIN	CN201		1
92		90G6059 1	HEAT SINK	U201		1
93		AUPC780B4SMTP	AUDIO BOARD			
94		AUPC780B4AIP	AUDIO BOARD			1
95		61L0603102	CHIPR 1KOHM +-5% 1/10W	R207		1
96		61L0603102	CHIPR 1KOHM +-5% 1/10W	R208		1
97		61L0603183	CHIP 18K OHM 1/10W	R201		1
98		61L0603183	CHIP 18K OHM 1/10W	R203		1
99		61L0603203	CHIPR 20KOHM +-5% 1/10W	R210		1
100		61L0603203	CHIPR 20KOHM +-5% 1/10W	R211		1
101		61L0603204	200K 0603	R202		1
102		65G0805101 31	CHIP 100PF 50V NPD 0805	C211		1
103		65G0805101 31	CHIP 100PF 50V NPD 0805	C212		1
104		65G0805104 32	CHIP 0.1UF 50V X7R 0805	C203		1
105		65G0805104 32	CHIP 0.1UF 50V X7R 0805	C213		1
106		65G0805474 22	CHIP 0.47UF 25V Y5V 0805	C204		1
107		65G0805474 22	CHIP 0.47UF 25V Y5V 0805	C206		1
108		AUPC780B4AIP	AUDIO BOARD			
109		61G 60218352T	18K OHM 5% 1/6	R301		1
110		61G 60218352T	18K OHM 5% 1/6	R302		1
111		61G 60222452T	220KOHM 5% 1/6W	R212		1
112		67G 2151007NT	10UF 50V	C209		1
113		67G 2151007NT	10UF 50V	C210		1
114		95G 90 23	TINCOATEDCOPPER	J201		1

115		95G 90 23	TINCOATEDCOPPER	J203		1
116		95G 90 23	TINCOATEDCOPPER	J205		1
117		95G 90 23	TINCOATEDCOPPER	J207		1
118		715G1841 C	AUDIO BOARD			1
119		CBPC780KK5VWAP	CONVERSION BOARD			
120		AIC780KK5VWAP	AIN BOARD			1
121		33G801714H H	PIN2*7	CN404		1
122		33G8027 12	WAFER 2*6P 2.0MM R/A	CN701		1
123		33G8027 16	WAFER 16PIN 2.0MM DIP	CN403		1
124		33G802724B H	WAFER&PLUG	CN101		1
125		40G 45762412B	CBPC LABEL			1
126		51G6002 1	导热胶			0.2
127		67G215L101 4N	LOW ESR EC 100UF 25V NCC	C707		1
128		67G215L101 4N	LOW ESR EC 100UF 25V NCC	C710		1
129		67G215L101 4N	LOW ESR EC 100UF 25V NCC	C712		1
130		67G305V100 3	CAPACITOR 10UF/16V	C408		1
131		67G305V100 3	CAPACITOR 10UF/16V	C717		1
132		67G305V479 3P	4.7UF 16V +-20% 105	C403		1
133		67G305V479 3P	4.7UF 16V +-20% 105	C702		1
134		88G 35315F H	D-SUB 15PIN	CN405		1
135		90G6250 1902	HEAT SINK	U401		1
136		90G6250 1903	HEAT SINK	U401		0
137		93G 22 53	CRYSTAL 14.31818MHZ HC-4	X401		1
138		93G 22 53 H	CRYSTAL 12.318180HMZ/HC-	X401		0
139		AIC780KK5VWAP	AIN BOARD			
140		56G 562100	TSUM16AK PQFP-128 IC	U401		1
141		56G 563 7	AIC1084-33PM TO-263	U702		1
142		56G 643 6	IC MICROPROCESSOR MAX810	U406		0
143		56G 643 20	RESET_4.38V_G690H438T73U	U406		1
144		56G1133 34	IC M24C02-WMN6TP	U404		1
145		56G1133 56	IC M24C16-WMN6TP	U403		1
146		56G1133 63KV3	PM25LV010-25SCE	U402		1
147		57G 417 4	PMBS3904/PLILIPS	Q402		1
148		57G 417 4	PMBS3904/PLILIPS	Q701		1
149		57G 417 4	PMBS3904/PLILIPS	Q703		1
150		57G 417 4	PMBS3904/PLILIPS	Q706		1
151		57G 417 6	PMBS3906 PNP	Q401		1
152		57G 417 6	PMBS3906 PNP	Q403		1
153		57G 417 17 T	PZT2907A SOT-223	Q702		1

154		57G 763 1	A03401L	Q704		1
155		61L0603000	CHIPR 00HM +-5% 1/10W	FB410		1
156		61L0603000	CHIPR 00HM +-5% 1/10W	FB411		1
157		61L0603000	CHIPR 00HM +-5% 1/10W	FB412		1
158		61L0603000	CHIPR 00HM +-5% 1/10W	R419		1
159		61L0603000	CHIPR 00HM +-5% 1/10W	R421		1
160		61L0603000	CHIPR 00HM +-5% 1/10W	R431		1
161		61L0603000	CHIPR 00HM +-5% 1/10W	R432		1
162		61L0603000	CHIPR 00HM +-5% 1/10W	R488		1
163		61L0603000	CHIPR 00HM +-5% 1/10W	R492		1
164		61L0603000	CHIPR 00HM +-5% 1/10W	R720		1
165		61L0603000	CHIPR 00HM +-5% 1/10W	R721		1
166		61L0603000	CHIPR 00HM +-5% 1/10W	R730		1
167		61L0603101	CHIPR 1000HM +-5% 1/10W	R411		1
168		61L0603101	CHIPR 1000HM +-5% 1/10W	R418		1
169		61L0603101	CHIPR 1000HM +-5% 1/10W	R420		1
170		61L0603101	CHIPR 1000HM +-5% 1/10W	R427		1
171		61L0603101	CHIPR 1000HM +-5% 1/10W	R428		1
172		61L0603101	CHIPR 1000HM +-5% 1/10W	R429		1
173		61L0603101	CHIPR 1000HM +-5% 1/10W	R441		1
174		61L0603101	CHIPR 1000HM +-5% 1/10W	R442		1
175		61L0603101	CHIPR 1000HM +-5% 1/10W	R443		1
176		61L0603101	CHIPR 1000HM +-5% 1/10W	R445		1
177		61L0603101	CHIPR 1000HM +-5% 1/10W	R453		1
178		61L0603101	CHIPR 1000HM +-5% 1/10W	R454		1
179		61L0603101	CHIPR 1000HM +-5% 1/10W	R704		1
180		61L0603102	CHIPR 1KOHM +-5% 1/10W	R430		1
181		61L0603102	CHIPR 1KOHM +-5% 1/10W	R446		1
182		61L0603102	CHIPR 1KOHM +-5% 1/10W	R447		1
183		61L0603102	CHIPR 1KOHM +-5% 1/10W	R476		1
184		61L0603102	CHIPR 1KOHM +-5% 1/10W	R701		1
185		61L0603103	CHIPR 10KOHM+-5% 1/10W	R406		1
186		61L0603103	CHIPR 10KOHM+-5% 1/10W	R408		1
187		61L0603103	CHIPR 10KOHM+-5% 1/10W	R412		1
188		61L0603103	CHIPR 10KOHM+-5% 1/10W	R413		1
189		61L0603103	CHIPR 10KOHM+-5% 1/10W	R415		1
190		61L0603103	CHIPR 10KOHM+-5% 1/10W	R416		1
191		61L0603103	CHIPR 10KOHM+-5% 1/10W	R424		1
192		61L0603103	CHIPR 10KOHM+-5% 1/10W	R425		1

193		61L0603103	CHIPR 10KOHM+-5% 1/10W	R426		1
194		61L0603103	CHIPR 10KOHM+-5% 1/10W	R444		1
195		61L0603103	CHIPR 10KOHM+-5% 1/10W	R452		1
196		61L0603103	CHIPR 10KOHM+-5% 1/10W	R470		1
197		61L0603103	CHIPR 10KOHM+-5% 1/10W	R484		1
198		61L0603103	CHIPR 10KOHM+-5% 1/10W	R485		1
199		61L0603103	CHIPR 10KOHM+-5% 1/10W	R486		1
200		61L0603103	CHIPR 10KOHM+-5% 1/10W	R708		1
201		61L0603103	CHIPR 10KOHM+-5% 1/10W	R711		1
202		61L0603103	CHIPR 10KOHM+-5% 1/10W	R714		1
203		61L0603103	CHIPR 10KOHM+-5% 1/10W	R717		1
204		61L0603103	CHIPR 10KOHM+-5% 1/10W	R727		1
205		61L0603104	CHIPR 100KOHM +-5% 1/10W	R487		1
206		61L0603121	CHIPR 120 OHM 1/10W	R409		1
207		61L0603121	CHIPR 120 OHM 1/10W	R414		1
208		61L0603202	CHIPR 2KOHM+-5%1/10W	R703		1
209		61L0603203	CHIPR 20KOHM +-5% 1/10W	R417		1
210		61L0603222	CHIPR 2.2KOHM+-5%1/10W	R448		1
211		61L0603222	CHIPR 2.2KOHM+-5%1/10W	R449		1
212		61L0603390 OF	3900HM +-1%	R403		1
213		61L0603392	CHIP 3.9K OHM 1/10W	R474		1
214		61L0603392	CHIP 3.9K OHM 1/10W	R475		1
215		61L0603392	CHIP 3.9K OHM 1/10W	R491		1
216		61L0603471	CHIPR 4700HM+-5%1/10W	R437		1
217		61L0603472	CHIP 4.7KOHM +-5% 1/10W	R405		1
218		61L0603472	CHIP 4.7KOHM +-5% 1/10W	R422		1
219		61L0603472	CHIP 4.7KOHM +-5% 1/10W	R423		1
220		61L0603472	CHIP 4.7KOHM +-5% 1/10W	R450		1
221		61L0603472	CHIP 4.7KOHM +-5% 1/10W	R451		1
222		61L0603472	CHIP 4.7KOHM +-5% 1/10W	R705		1
223		61L0603472	CHIP 4.7KOHM +-5% 1/10W	R707		1
224		61L0603472	CHIP 4.7KOHM +-5% 1/10W	R712		1
225		61L0603472	CHIP 4.7KOHM +-5% 1/10W	R725		1
226		61L0603510	CHIP 510HM 5% 1/10W	R702		1
227		61L0603513	CHIP 51K OHM	R723		1
228		61L0603560	CHIPR 56 OHM +-5% 1/10W	R434		1
229		61L0603560	CHIPR 56 OHM +-5% 1/10W	R435		1
230		61L0603560	CHIPR 56 OHM +-5% 1/10W	R436		1
231		61L0603750	CHIPR 750HM+-5%1/10W	R438		1

232		61L0603750	CHIPR 750HM+-5%1/10W	R439		1
233		61L0603750	CHIPR 750HM+-5%1/10W	R440		1
234		65G0603104 32	CHIP 0.1UF 50V X7R	C401		1
235		65G0603104 32	CHIP 0.1UF 50V X7R	C404		1
236		65G0603104 32	CHIP 0.1UF 50V X7R	C405		1
237		65G0603104 32	CHIP 0.1UF 50V X7R	C406		1
238		65G0603104 32	CHIP 0.1UF 50V X7R	C407		1
239		65G0603104 32	CHIP 0.1UF 50V X7R	C409		1
240		65G0603104 32	CHIP 0.1UF 50V X7R	C410		1
241		65G0603104 32	CHIP 0.1UF 50V X7R	C411		1
242		65G0603104 32	CHIP 0.1UF 50V X7R	C412		1
243		65G0603104 32	CHIP 0.1UF 50V X7R	C413		1
244		65G0603104 32	CHIP 0.1UF 50V X7R	C414		1
245		65G0603104 32	CHIP 0.1UF 50V X7R	C415		1
246		65G0603104 32	CHIP 0.1UF 50V X7R	C416		1
247		65G0603104 32	CHIP 0.1UF 50V X7R	C417		1
248		65G0603104 32	CHIP 0.1UF 50V X7R	C419		1
249		65G0603104 32	CHIP 0.1UF 50V X7R	C420		1
250		65G0603104 32	CHIP 0.1UF 50V X7R	C422		1
251		65G0603104 32	CHIP 0.1UF 50V X7R	C424		1
252		65G0603104 32	CHIP 0.1UF 50V X7R	C425		1
253		65G0603104 32	CHIP 0.1UF 50V X7R	C426		1
254		65G0603104 32	CHIP 0.1UF 50V X7R	C427		1
255		65G0603104 32	CHIP 0.1UF 50V X7R	C428		1
256		65G0603104 32	CHIP 0.1UF 50V X7R	C429		1
257		65G0603104 32	CHIP 0.1UF 50V X7R	C430		1
258		65G0603104 32	CHIP 0.1UF 50V X7R	C439		1
259		65G0603104 32	CHIP 0.1UF 50V X7R	C440		1
260		65G0603104 32	CHIP 0.1UF 50V X7R	C441		1
261		65G0603104 32	CHIP 0.1UF 50V X7R	C444		1
262		65G0603104 32	CHIP 0.1UF 50V X7R	C706		1
263		65G0603104 32	CHIP 0.1UF 50V X7R	C709		1
264		65G0603104 32	CHIP 0.1UF 50V X7R	C711		1
265		65G0603104 32	CHIP 0.1UF 50V X7R	C713		1
266		65G0603104 32	CHIP 0.1UF 50V X7R	C714		1
267		65G0603104 32	CHIP 0.1UF 50V X7R	C715		1
268		65G0603104 32	CHIP 0.1UF 50V X7R	C718		1
269		65G0603105 12	CHIP CAP 1UF.	C708		1
270		65G0603220 32	Chip Cap 22PF	C421		1

271		65G0603220 32	Chip Cap 22PF	C423		1
272		65G0603221 32	220PF/50V X7R	C443		1
273		65G0603330 32	CHIP 33PF 50V NPO	C442		1
274		65G0603473 32	CHIP 47NF 50V X7R	C432		1
275		65G0603473 32	CHIP 47NF 50V X7R	C433		1
276		65G0603473 32	CHIP 47NF 50V X7R	C434		1
277		65G0603473 32	CHIP 47NF 50V X7R	C435		1
278		65G0603473 32	CHIP 47NF 50V X7R	C436		1
279		65G0603473 32	CHIP 47NF 50V X7R	C437		1
280		65G0603473 32	CHIP 47NF 50V X7R	C438		1
281		71G 56Z601	2.0X1.2 100M=6000HM	FB401		1
282		71G 56Z601	2.0X1.2 100M=6000HM	FB402		1
283		71G 56Z601	2.0X1.2 100M=6000HM	FB403		1
284		71G 56Z601	2.0X1.2 100M=6000HM	FB404		1
285		71G 56Z601	2.0X1.2 100M=6000HM	FB405		1
286		71G 56Z601	2.0X1.2 100M=6000HM	FB406		1
287		71G 56Z601	2.0X1.2 100M=6000HM	FB407		1
288		71G 56Z601	2.0X1.2 100M=6000HM	FB408		1
289		71G 59B121	贴片磁珠	FB409		1
290		93G 39149	ZENER MLL5232B BY FULL P	D406		1
291		93G 39149	ZENER MLL5232B BY FULL P	D408		1
292		93G 39149	ZENER MLL5232B BY FULL P	D409		1
293		93G 39149	ZENER MLL5232B BY FULL P	D410		1
294		93G 39149	ZENER MLL5232B BY FULL P	D411		1
295		93G 39149	ZENER MLL5232B BY FULL P	D412		1
296		93G 64 42 P	BAV70 DIODE	D407		1
297		93G 6432P	LL4148 MINI-MELF/LL-34	D701		1
298		93G 6432P	LL4148 MINI-MELF/LL-34	D702		1
299		93G 6433P	BAV99 SOT-23	D403		1
300		93G 6433P	BAV99 SOT-23	D404		1
301		93G 6433P	BAV99 SOT-23	D405		1
302		93G 39S 45 T	RLZ36B ZENER DIODE	D401		1
303		93G 39S 45 T	RLZ36B ZENER DIODE	D402		1
304		93G 39S 45 T	RLZ36B ZENER DIODE	D425		1
305		93G1004 4	SCHOTTKY DIODE 1A 40V SM	D704		1
306		715G1558 1 VS	MAIN PCB			1
307		KEPC560KD9P	KEPC BOARD			
308		KEPC560KD9SMT	KEPC BOARD FOR SMT			1
309		33G3802 2H	WAFER	CN3		1

310		33G3802 2H	WAFER	CN4		1
311		33G8027 12 H	WAFER 2*6P 2.0mm R/A	CN001		1
312		77G 600 1GCJ	轻触开关	SW1		1
313		77G 600 1GCJ	轻触开关	SW2		1
314		77G 600 1GCJ	轻触开关	SW3		1
315		77G 600 1GCJ	轻触开关	SW4		1
316		77G 600 1GCJ	轻触开关	SW5		1
317		81G 12 1 GP	LED GP32032ME/R003-50-ZY	DP1		1
318		KEPC560KD9SMTP	KEPC BOARD FOR SMT			
319		KEPC560KD9AIP	KEPC BOARD			1
320		71G 59B121	贴片磁珠	FB01		1
321		71G 59B121	贴片磁珠	FB02		1
322		KEPC560KD9AIP	KEPC BOARD			
323		95G 90 23	TINCOATEDCOPPER	J12		1
324		95G 90 23	TINCOATEDCOPPER	J13		1
325		95G 90 23	TINCOATEDCOPPER	J14		1
326		95G 90 23	TINCOATEDCOPPER	J15		1
327		95G 90 23	TINCOATEDCOPPER	J16		1
328		715G1898 1	PCB			1
329		PWPC1742HDV3P	POWER BOARD			
330		PW1742HDV3SMTP	POWER BOARD FOR SMT			1
331		S80GL17T33V	变压器组件	T901		0
332		S80GL17T36V	变压器组件	PT801		0
333		S80GL17T36V	变压器组件	PT802		0
334		9G6005 1	PIN FOOT	GND1		1
335		9G6005 1	PIN FOOT	GND2		1
336		33G8021 2D U	CON.2PR/A	CN801		1
337		33G8021 2D U	CON.2PR/A	CN802		1
338		33G8021 2D U	CON.2PR/A	CN803		1
339		33G8021 2D U	CON.2PR/A	CN804		1
340		33G8021 2D AC	WAFER	CN801		0
341		33G8021 2D AC	WAFER	CN802		0
342		33G8021 2D AC	WAFER	CN803		0
343		33G8021 2D AC	WAFER	CN804		0
344		40G 45762412B	CBPC LABEL			1
345		51G 6 4503	RTV 胶			2
346		56G 139 3A	PC123Y22FZOF	IC902		1
347		61G 58080 WT	NTCR	NR901		1
348		61G152M438 64	RES	R916		1

349		63G 107474 HS	X2 CAP. 0.47UF	C909		0
350		63G 10747410S	0.47UF +-10% 250VAC	C909		1
351		65G 3J1206ET	12PF 5% SL 3KV TDK	C816		1
352		65G 3J1206ET	12PF 5% SL 3KV TDK	C825		1
353		65G 3J3096ET	3PF ,J, 3KV .Z5P	C817		1
354		65G 3J3096ET	3PF ,J, 3KV .Z5P	C826		1
355		65G305M1022EM	1000pF Y2 250V 20% BY MU	C901		1
356		65G305M1022EM	1000pF Y2 250V 20% BY MU	C902		1
357		65G306M2222BP	2200PF Y1 400 20% BY UK	C900		1
358		67G 2154713KT	EC CAP 105 470uF 16V	C927		0
359		67G215H471 4K	LOW ESR EC 470UF 25V	C811		0
360		67G215H471 4K	LOW ESR EC 470UF 25V	C820		0
361		67G215H471 4K	LOW ESR EC 470UF 25V	C925		0
362		67G215L1023HS	EC 1000uF 16V LLR102M1CG	C926		0
363		67G215L4713HL	LOW ESR EC. 470uF 16V	C927		1
364		67G215S10115H	100UF 450WV 105 18*36M	C907		1
365		67G215S10115K	LOW ESR EC 100uF 450V	C907		0
366		67G215S102 3K	ED1000UF 16V	C926		1
367		67G215S4714KL	LOW ESR EC 470UF 25V	C811		0
368		67G215S4714KL	LOW ESR EC 470UF 25V	C820		0
369		67G215S4714KL	LOW ESR EC 470UF 25V	C925		0
370		67G215S6814KL	EC 105 680UF M 25V KIN	C922		0
371		67G215S6814KL	EC 105 680UF M 25V KIN	C923		0
372		67G215S6814KL	EC 105 680UF M 25V KIN	C924		0
373		67G215Y471 4H	EC CAP 105 度 470UF 25V	C811		1
374		67G215Y471 4H	EC CAP 105 度 470UF 25V	C820		1
375		67G215Y471 4H	EC CAP 105 度 470UF 25V	C925		1
376		67G215Y681 4H	EC 680uF 25V ZLR681M1EG1	C922		1
377		67G215Y681 4H	EC 680uF 25V ZLR681M1EG1	C923		1
378		67G215Y681 4H	EC 680uF 25V ZLR681M1EG1	C924		1
379		73G 174 65 H	LINE FILTER	L902		1
380		73G 174 65 LS	LINE FILTER	L902		0
381		73G 174 76 L	CHOKE COIL CC-004668	L901		1
382		73G 174 76 LS	LINE FILTER LISHIN	L901		0
383		73G 174 76 YS	CHOKE COIL YSFDA550135G	L901		0
384		73G 253 91 H	阻流圈	L921		0
385		73G 253 91 H	阻流圈	L922		0
386		73G 253 91 S	阻流圈	L921		1
387		73G 253 91 S	阻流圈	L922		1

388		80GL17T 33 N	X'FMR YUVA-644	T901		1
389		80GL17T 33 T	X'FMR SRW28EC-T133H0110	T901		0
390		80GL17T 36 H	XFMR FOR INVERTER	PT801		0
391		80GL17T 36 H	XFMR FOR INVERTER	PT802		0
392		80GL17T 36 DN	X'FMR TK.2039M.101	PT801		1
393		80GL17T 36 DN	X'FMR TK.2039M.101	PT802		1
394		80GL17T 36 YS	SFMR FOR INVERTER TOP NA	PT801		0
395		80GL17T 36 YS	SFMR FOR INVERTER TOP NA	PT802		0
396		87G 501 32 S	AC SOCKET	CN901		1
397		93G 50460 13	KBP206G 2A 600V	BD901		1
398		93G 50460502	BRIDGE KBP206G 2A 800V	BD901		0
399		93G3006 1	DIODE 31DQ06FC	D922		1
400		95G8014 12701 Q	HARNESS	CN902		0
401		95G8014 12701 W	WIRE HARNESS	CN902		1
402		95G8014 12701 X	WIRE HARNESS	CN902		0
403		705G 900 11 06	Q900 ASS'Y			1
404		705G 909 11 06	R909 ASS'Y			1
405		705G 920 06 14	D920 ASS'Y			1
406		705G D90 11 06	D900 ASS'Y			1
407		Q85G0003 1	SHIELD	HS6		1
408		PW1742HDV3SMTP	POWER BOARD FOR SMT			
409		PW1742HDV3AIP	POWER BOARD FOR AI			1
410		56G 379 61	LD7575 PS SOP-8	IC901		1
411		56G 608 10	OZ9938GN SOIC-16	IC801		1
412		57G 417 4	PMBS3904/PLILIPS	Q801		1
413		57G 417 4	PMBS3904/PLILIPS	Q802		1
414		57G 417 4	PMBS3904/PLILIPS	Q803		1
415		57G 763 14	AM9945N-T1-PF SOIC-8	Q805		1
416		57G 763 14	AM9945N-T1-PF SOIC-8	Q806		1
417		61L0805100	CHIPR 10 OHM +-5% 1/8W	R837		1
418		61L0805100	CHIPR 10 OHM +-5% 1/8W	R842		1
419		61L0805100 3F	CHIP 100KOHM +-1% 1/8W	R821		1
420		61L0805100 3F	CHIP 100KOHM +-1% 1/8W	R831		1
421		61L0805101	CHIPR 100OHM+-5%1/8W	R927		1
422		61L0805101	CHIPR 100OHM+-5%1/8W	R930		1
423		61L0805102	CHIPR 1K OHM +-5% 1/8W	R836		1
424		61L0805102	CHIPR 1K OHM +-5% 1/8W	R843		1
425		61L0805102	CHIPR 1K OHM +-5% 1/8W	R913		1
426		61L0805102	CHIPR 1K OHM +-5% 1/8W	R925		1

427		61L0805102	CHIPR 1K OHM +-5% 1/8W	R928		1
428		61L0805103	CHIPR 10KOHM+-5%1/8W	R803		1
429		61L0805103	CHIPR 10KOHM+-5%1/8W	R812		1
430		61L0805103	CHIPR 10KOHM+-5%1/8W	R915		1
431		61L0805103	CHIPR 10KOHM+-5%1/8W	R923		1
432		61L0805104	CHIPR 100K OHM +-5% 1/8W	R810		1
433		61L0805104	CHIPR 100K OHM +-5% 1/8W	R815		1
434		61L0805104	CHIPR 100K OHM +-5% 1/8W	R911		1
435		61L0805105	CHIP 1M OHM 5% 1/8W	R809		1
436		61L0805105	CHIP 1M OHM 5% 1/8W	R813		1
437		61L0805105	CHIP 1M OHM 5% 1/8W	R816		1
438		61L0805150 2F	CHIPR 15KOHM+-1% 1/8W	R820		1
439		61L0805150 2F	CHIPR 15KOHM+-1% 1/8W	R830		1
440		61L0805154	CHIP 150KOHM 5% 1/8W	R811		1
441		61L0805240 1F	CHIPR 2.4KOHM +-1% 1/8W	R929		1
442		61L0805330 2F	CHIP 33KOHM 1/8W/1%	R926		1
443		61L0805360 0F	360 OHM	R841		1
444		61L0805360 1F	CHIP 3.6KOHM 1/8W 1%	R827		1
445		61L0805360 1F	CHIP 3.6KOHM 1/8W 1%	R834		1
446		61L0805360 1F	CHIP 3.6KOHM 1/8W 1%	R924		1
447		61L0805390 0F	CHIPR 390OHM +-1% 1/8W	R826		1
448		61L0805390 2F	CHIP 39K 1/10W 1%	R817		1
449		61L0805561	CHIPR 560 OHM +-5% 1/8W	R825		1
450		61L0805561	CHIPR 560 OHM +-5% 1/8W	R835		1
451		61L0805563	CHIP 56K OHM 5% 1/10W	R814		1
452		61L1206000	CHIPR 0OHM+-5% 1/4W	C835		1
453		61L1206000	CHIPR 0OHM+-5% 1/4W	C836		1
454		61L1206000	CHIPR 0OHM+-5% 1/4W	C837		1
455		61L1206000	CHIPR 0OHM+-5% 1/4W	C838		1
456		61L1206000	CHIPR 0OHM+-5% 1/4W	F902		1
457		61L1206000	CHIPR 0OHM+-5% 1/4W	F903		1
458		61L1206000	CHIPR 0OHM+-5% 1/4W	RJ801		1
459		61L1206000	CHIPR 0OHM+-5% 1/4W	RJ901		1
460		61L1206000	CHIPR 0OHM+-5% 1/4W	RJ902		1
461		61L1206100	CHIPR 10 OHM +-5% 1/4W	R912		1
462		61L1206103	CHIP 10KOHM 5% 1/4W	R804		1
463		61L1206103	CHIP 10KOHM 5% 1/4W	R905		1
464		61L1206103	CHIP 10KOHM 5% 1/4W	R931		1
465		61L1206150	CHIP 15 OHM 5% 1206 1/4	R818		1

466		61L1206150	CHIP 15 OHM 5% 1206 1/4	R819		1
467		61L1206150	CHIP 15 OHM 5% 1206 1/4	R828		1
468		61L1206150	CHIP 15 OHM 5% 1206 1/4	R829		1
469		61L1206220	CHIP 220HM 1/8W	R807		1
470		61L1206304	CHIP 300K OHM 1/4W	R802		1
471		61L1206334	330K 1/4W	R900		1
472		61L1206334	330K 1/4W	R901		1
473		61L1206334	330K 1/4W	R902		1
474		61L1206470	CHIP 470HM 5% 1/4W	R951		1
475		61L1206470	CHIP 470HM 5% 1/4W	R952		1
476		61L1206470	CHIP 470HM 5% 1/4W	R954		1
477		61L1206470	CHIP 470HM 5% 1/4W	R955		1
478		61L1206471	CHIPR 470 OHM +-5% 1/4W	R805		1
479		61L1206474	470KOHM CHIP	R808		1
480		61L1206759	SMD 7R50HM/1206/+5% 1/4	R910		1
481		65G0805101 31	CHIP 100PF 50V NPD 0805	C833		1
482		65G0805102 31	1000PF 50V NPO	C914		1
483		65G0805102 32	CHIP 1000PF 50V X7R 0805	C805		1
484		65G0805103 32	CHIP 10000 PF 50V X7R 08	C803		1
485		65G0805103 32	CHIP 10000 PF 50V X7R 08	C807		1
486		65G0805104 32	CHIP 0.1UF 50V X7R 0805	C912		1
487		65G0805104 32	CHIP 0.1UF 50V X7R 0805	C916		1
488		65G0805104 32	CHIP 0.1UF 50V X7R 0805	C928		1
489		65G0805104 32	CHIP 0.1UF 50V X7R 0805	C929		1
490		65G0805104 32	CHIP 0.1UF 50V X7R 0805	C930		1
491		65G0805104 32	CHIP 0.1UF 50V X7R 0805	C931		1
492		65G0805105 22	CHIP 1UF 25V X7R 0805	C806		1
493		65G0805152 32	贴片电容	C812		1
494		65G0805152 32	贴片电容	C813		1
495		65G0805152 32	贴片电容	C822		1
496		65G0805152 32	贴片电容	C823		1
497		65G0805221 32	CHIP 220PF 50V X7R	C913		1
498		65G0805223 22	E65	C819		1
499		65G0805225 12	CHIP 2.2UF 15V X7R 0805	C804		1
500		65G0805271 31	CHIP 270pF 50V NPO 0805	C818		1
501		65G0805271 31	CHIP 270pF 50V NPO 0805	C827		1
502		65G0805271 31	CHIP 270pF 50V NPO 0805	C831		1
503		65G0805471 31	CHIP 470PF 50V NPO	C810		1
504		65G0805473 32	SMD 47NF +-10% 50V	C809		1

505		65G0805682 32	CHIP 6.8nF 50V X7R 0805	C808		1
506		93G 64 33	BAV99 SOT-23	D802		0
507		93G 64 33	BAV99 SOT-23	D804		0
508		93G 64 42 P	BAV70 DIODE	D801		0
509		93G 64 42 P	BAV70 DIODE	D803		0
510		93G 64 42 PP	DIODE BAV70 SOT-23	D801		1
511		93G 64 42 PP	DIODE BAV70 SOT-23	D803		1
512		93G 64 44 S	CHIP DIODE LL4148WP	D910		1
513		93G 64 44 S	CHIP DIODE LL4148WP	D915		1
514		93G 64 44 S	CHIP DIODE LL4148WP	D916		1
515		93G 6433P	BAV99 SOT-23	D802		1
516		93G 6433P	BAV99 SOT-23	D804		1
517		93G 39S 24 T	RLZ5.6B ROHM	ZD801		1
518		93G 39S 25 T	RLZ5.1B ROHM	ZD922		1
519		93G 39S 38 T	PTZ9.1B ROHM	ZD920		1
520		93G 39S 40 T	RLZ13B ROHM	ZD921		1
521		93G 39S 70 T	TPSMP91A-E3	ZD920		0
522		PW1742HDV3AIP	POWER BOARD FOR AI			
523		6G 31500	EYELET	CN901		2
524		6G 31502	1.5MM RIVET	C907		2
525		6G 31502	1.5MM RIVET	L901		4
526		6G 31502	1.5MM RIVET	L902		4
527		6G 31502	1.5MM RIVET	NR901		2
528		6G 31502	1.5MM RIVET	PT801		2
529		6G 31502	1.5MM RIVET	PT802		2
530		6G 31502	1.5MM RIVET	Q900		1
531		6G 31502	1.5MM RIVET	R916		2
532		6G 31502	1.5MM RIVET	T901		5
533		56G 158 10 T	IC AZ431AZ-AE1 TO-92	IC921		0
534		56G 158 12	KIA431A-AT/P TO-92 IC	IC921		1
535		61G 17222152T	220OHM 5% 1/4W	R922		1
536		61G212Y305 KT	MGFR 3M OHM +-5% 1/2W	R822		1
537		61G212Y305 KT	MGFR 3M OHM +-5% 1/2W	R832		1
538		65G 1K152 1T	1500PF +/-10% 1KV Y5P	C910		1
539		65G517K102 5T	1000PF 10% Y5P 500V	C920		1
540		65G517K102 5T	1000PF 10% Y5P 500V	C921		1
541		67G 2152207NT	22UF/50V	C911		1
542		67G 2152207RT	22UF +-20% 50V	C911		0
543		84G 55 2	FUSE 2.5A 250V MET250	F901		1

544		93G1020 752T	UF4003PT DO-41 DIODE 1A	D901		1
545		95G 90 23	TINCOATEDCOPPER	J811		1
546		95G 90 23	TINCOATEDCOPPER	J812		1
547		95G 90 23	TINCOATEDCOPPER	J814		1
548		95G 90 23	TINCOATEDCOPPER	J815		1
549		95G 90 23	TINCOATEDCOPPER	J816		1
550		95G 90 23	TINCOATEDCOPPER	J817		1
551		95G 90 23	TINCOATEDCOPPER	J818		1
552		95G 90 23	TINCOATEDCOPPER	J820		1
553		95G 90 23	TINCOATEDCOPPER	J821		1
554		95G 90 23	TINCOATEDCOPPER	J822		1
555		95G 90 23	TINCOATEDCOPPER	J823		1
556		95G 90 23	TINCOATEDCOPPER	J824		1
557		95G 90 23	TINCOATEDCOPPER	J825		1
558		95G 90 23	TINCOATEDCOPPER	J826		1
559		95G 90 23	TINCOATEDCOPPER	J827		1
560		95G 90 23	TINCOATEDCOPPER	J901		1
561		95G 90 23	TINCOATEDCOPPER	J902		1
562		95G 90 23	TINCOATEDCOPPER	J903		1
563		95G 90 23	TINCOATEDCOPPER	J904		1
564		95G 90 23	TINCOATEDCOPPER	J905		1
565		95G 90 23	TINCOATEDCOPPER	J906		1
566		95G 90 23	TINCOATEDCOPPER	J907		1
567		95G 90 23	TINCOATEDCOPPER	J908		1
568		95G 90 23	TINCOATEDCOPPER	J909		1
569		95G 90 23	TINCOATEDCOPPER	J910		1
570		95G 90 23	TINCOATEDCOPPER	J911		1
571		715G1823 1	POWER BOARD			1
572		705G 900 11 06	Q900 ASS'Y			
573		51G 200 1	散热油			2
574		57G 667 46	MOSFET_6A/600V_2SK2628LS	Q900		0
575		57G 667 47	MOSFET_7.5A/600V_FQPF8N6	Q900		1
576		90G6264 1	HEAT SINK	HS4 Q90		1
577		M1G1730 8128	SCREW			1
578		705G 909 11 06	R909 ASS'Y			
579		61G152M10458G	100K OHM 5% 2W	R909		1
580		96G 29 6	SHRINK TUBE UL/CSA			20
581		705G 920 06 14	D920 ASS'Y			
582		51G 200 1	散热油			2

583		90G6264 1	HEAT SINK	HS3 D92		1
584		93G 60237	DIODE SRF20100C	D920		0
585		93G 60276	DIODE_15A/100V_SBT150-10	D920		1
586		M1G1730 10128	SCREW			1
587		705G D90 11 06	D900 ASS'Y			
588		93G1100 1052T	BA159GPT DO-41 DIODE 1A	D900		1
589		96G 29 1	H.S.TUBE			12

8. Exploded Diagram And Spare Parts List

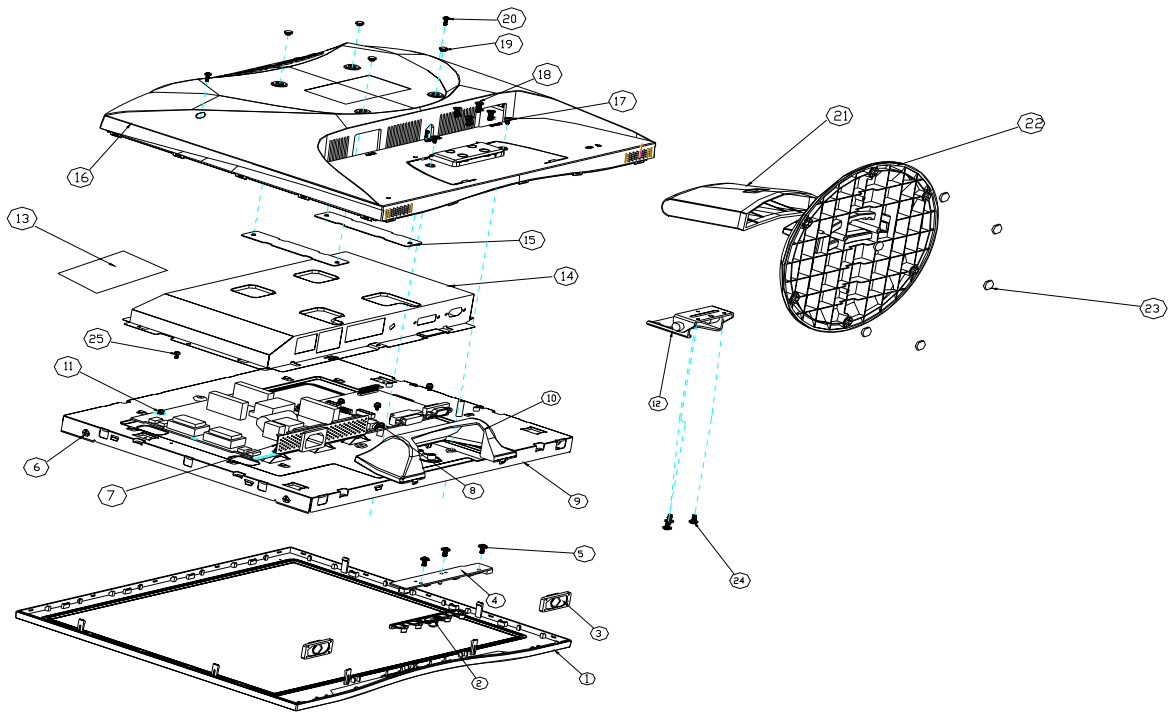

VA703m EPL Part List

ITEM	DESCRIPTION	PART NUMBER	Q'TY
1	BEZEL	A34G0026AKD L	1
2	FUNC.BUTTON	33G5019 KD C	1
3	SPEAKER,8OHM 1.5W	78G 455 3 K	2
4	KEPC BOARD	KEPC560KD9P	1
5	SCREW	Q1G 330 6120	3
6	SCREW	M1G 130 5120	4
7	AC SOCKET BRKT	J15G8313 1	1
8	SCREW	M1G1730 6120	5
9	MAIN FRAME HYDIS	J15G8312 1	1
10	HINGE COVER	A34G0029 KR L	1
11	SCREW	M1G1730 6120	4
12	HINGE	37G 561 1	1
13	绝缘片	Q52G6025 11997	1
14	MAIN SHIELD	J85G 740 1 3	1
15	VESA PLATE	J15G0013 1	2
16	REAR COVER	A34G0025 KR 1L	1
17	SCREW	M1G 330 6 47	2
18	SCREW	M1G2640 8 47	4
19	VESA RUBBER	J12G 808 1	4
20	SCREW	M1G 330 6 47	2
21	STAND	A34G0027 KR L	1
22	BASE	A34G0028 KR L	1
23	FOOT	J12G 394800	6
24	SCREW	Q1G1140 8120	3
25	SCREW	M1G 330 4120	4

Packing For Shipping

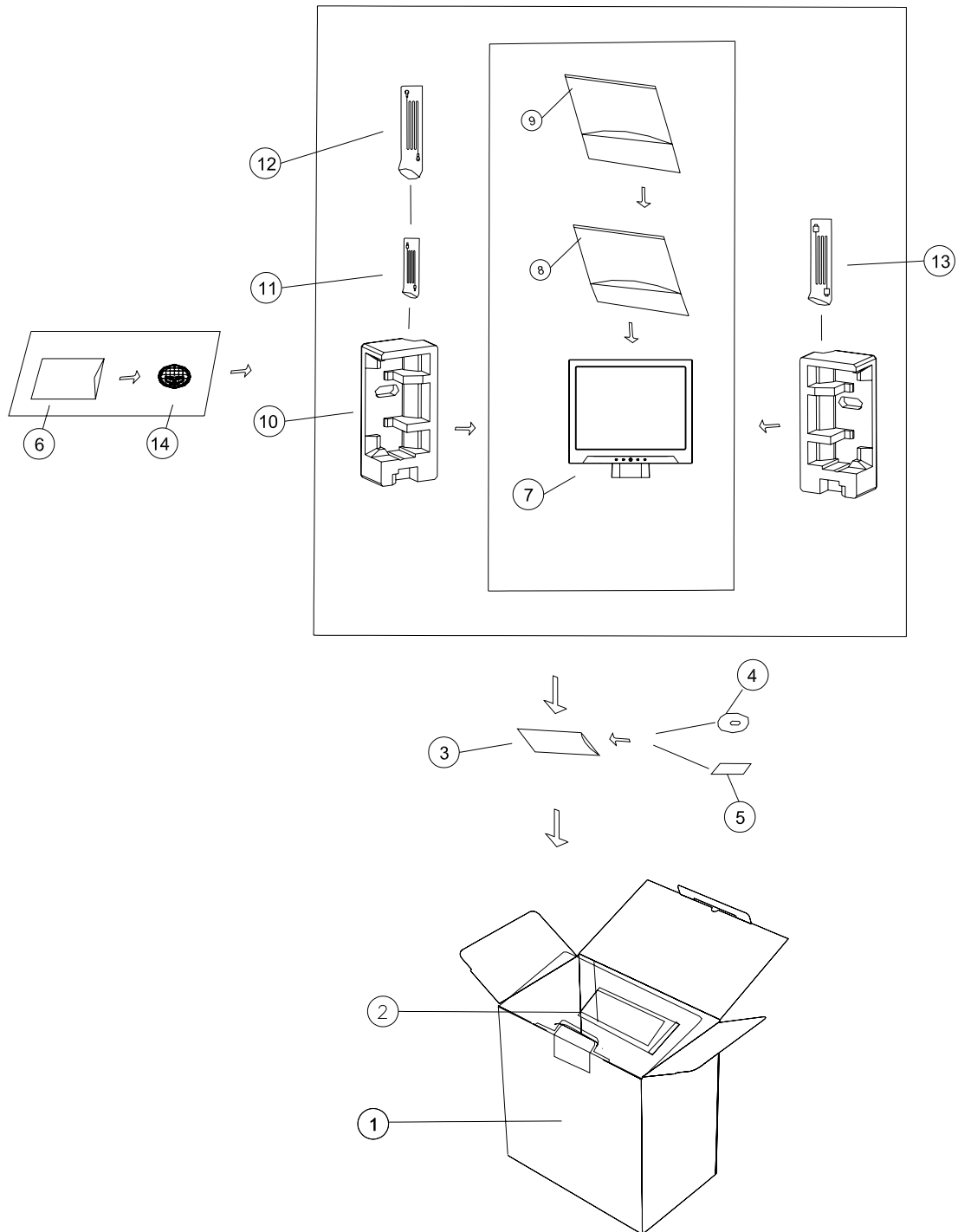

Packing Part List

ITEM	DESCRIPITON	PART NUMBER	Q'TY
1	CARTON	J44G7003709 2A	1
2	HANDLE1	50G 600 2	1
	HANDLE2	50G 600 3	1
3	PE BAG	45G 76 28 V3	1
4	CD MANUAL	J70G170170913A	1
5	QSG	J41G7801709 7A	1
6	PE BAG FOR BASE	45G 88606	1
7	MONITOR	T780KK5HKUVWABP	1
8	EPE BAG	45G 88609 B	1
9	PE BAG	45G 88607	1
10	EPS	J44G7003 1	1
		J44G7003 2	1
11	AUDIO CABLE	89G 173 56 31	1
12	POWER CORD	89G402A18N LS	1
13	SIGNAL CABLE	89G 725HAA903	1
14	BASE	A34G0028 KR L	1

9. Disassemble Process

9.1 Units Disassemble Process

9.1.1 Tools

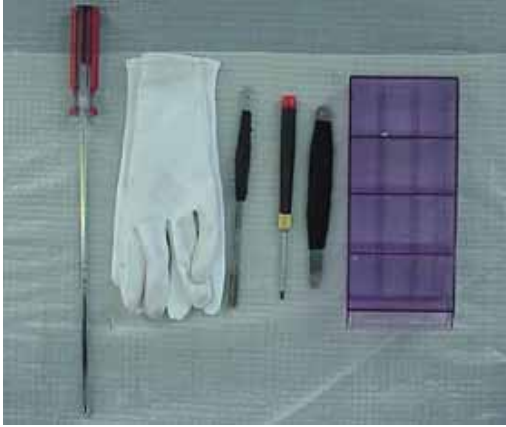

- ✧ Glove
- ✧ Big cross screwdriver
- ✧ Small cross screwdriver
- ✧ Prize equipment or abandoned IC card
- ✧ Screw box
- ✧ Cushion
- ✧ Six angle sleeve spanner

9.1.2 Disassemble process

- 1、Tide up the worktable, spread straight cushion, put the monitor on it, the front side adown.(**Picture 1**)
- 2、Remove the decorate slice of the back cover.(**Picture 2, 3**)
- 3、Disassemble the 4 screws that fix the stand, remove the stand..(**Picture, 4**)
- 4、Disassemble the 4 screws of the back cover. (**Picture 5**)
- 5、Use equipment or abandoned IC card to prize up the bezel through the bottom flute, and rip up the bezel downwards.(as showed in the following the **picture 6,7,8**)
- 6、Disassemble the 3 screws and 3 pins of the Key board, remove the Key board. (as showed in the following the **picture 9,10**)
- 7、Remove the back cover, refer to the following **picture 11**.
- 8、Disassemble the 6 fixed screw in the shield, remove the shield as the direction arrowhead showed, refer to the following **picture 12**.
- 9、Disassemble the 5 screws and 5 pins of the PWPC board, remove the PWPC board.(symbolized the following **picture 13** with red color)
- 10、Disassemble the 2 screws and 1 pins of the audio board, remove the audio board. (symbolized the following **picture 13** with yellow color)
- 11、Disassemble the 3 screws and 2 pins of the main board, remove the main board. (symbolized the following **picture 13,14** with blue color)
- 12、Disassemble the 4 fixed screws of the panel, remove the main frame, as showed in the following the **picture 15,16,17**. Do not damage the cable of the panel.
- 13、That's all. The disassemble process of the unit is over.

9.1.3 Show pictures :



(Picture 1)

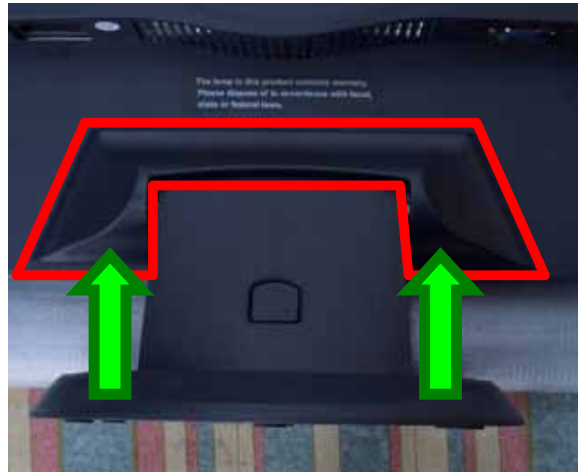

(Picture 2)



(Picture 3)



(Picture 4)



(Picture 5)



(Picture 6)



(Picture 7)



(Picture 8)

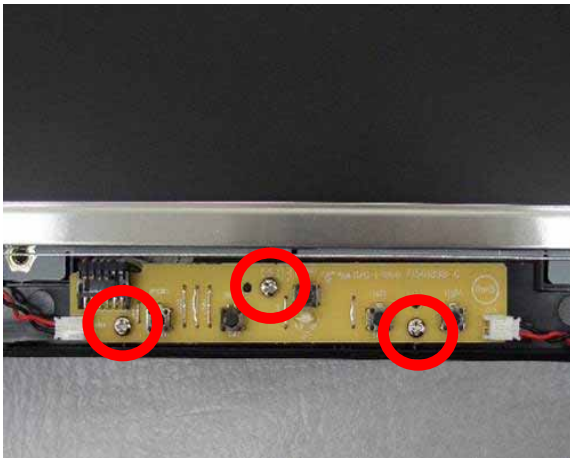

(Picture 9)

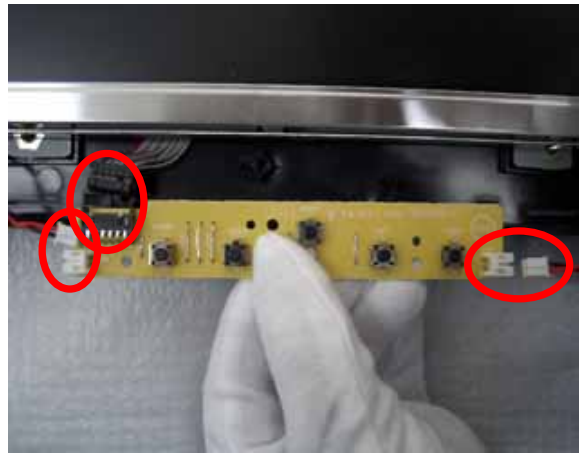

(Picture 10)

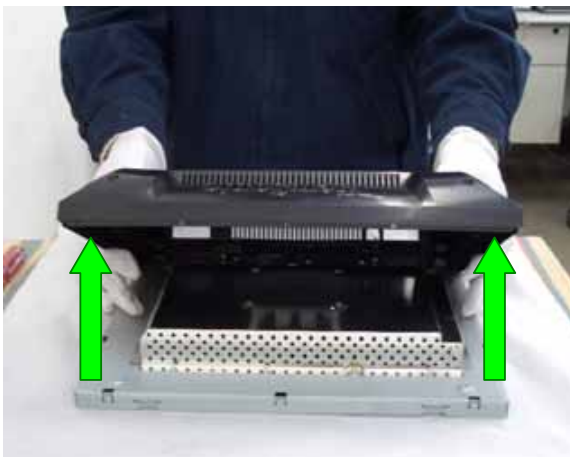

(Picture 11)

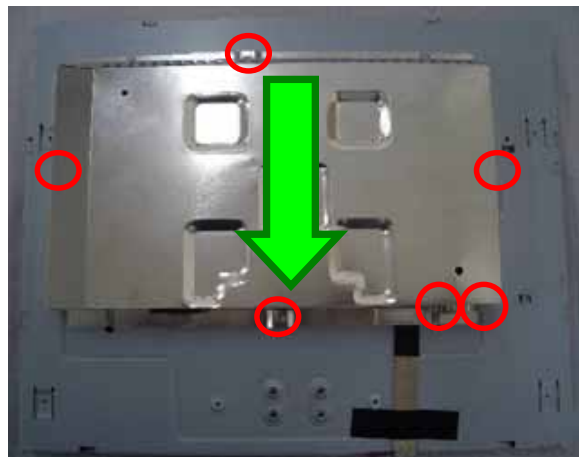

(Picture 12)

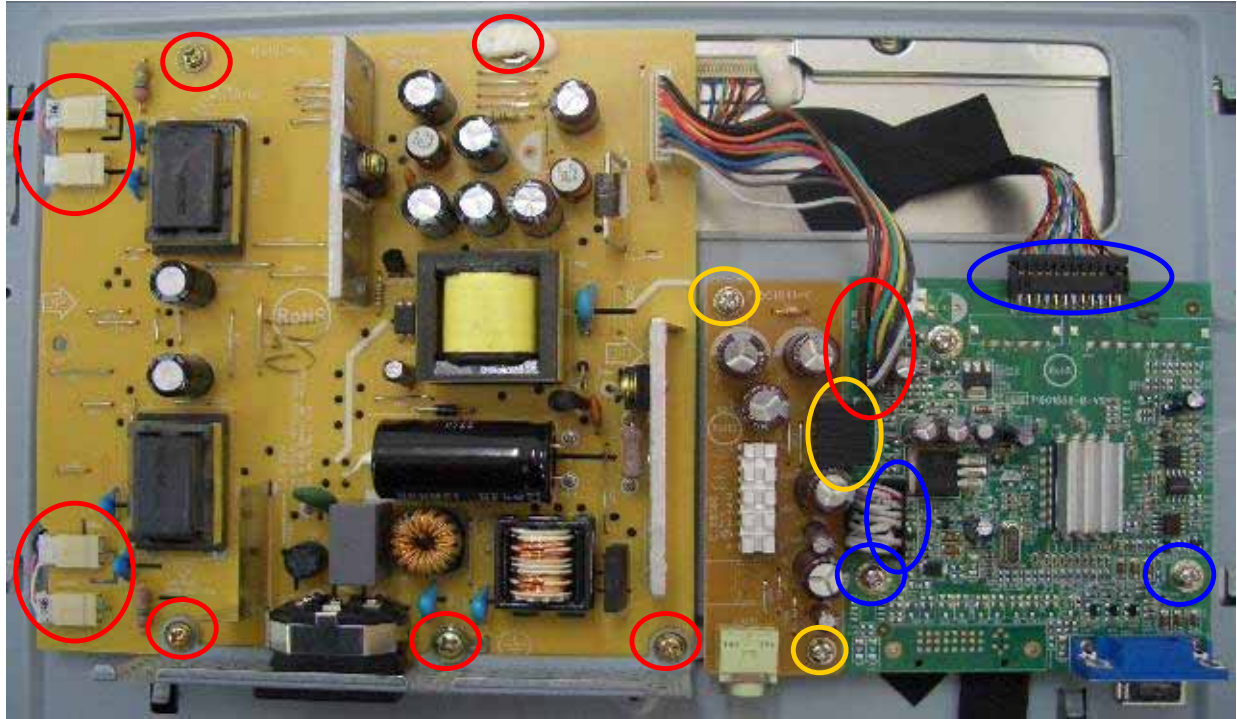

(Picture 13)



(Picture 14)



(Picture 15)



(Picture 16)



(Picture 17)

10. Block Diagram

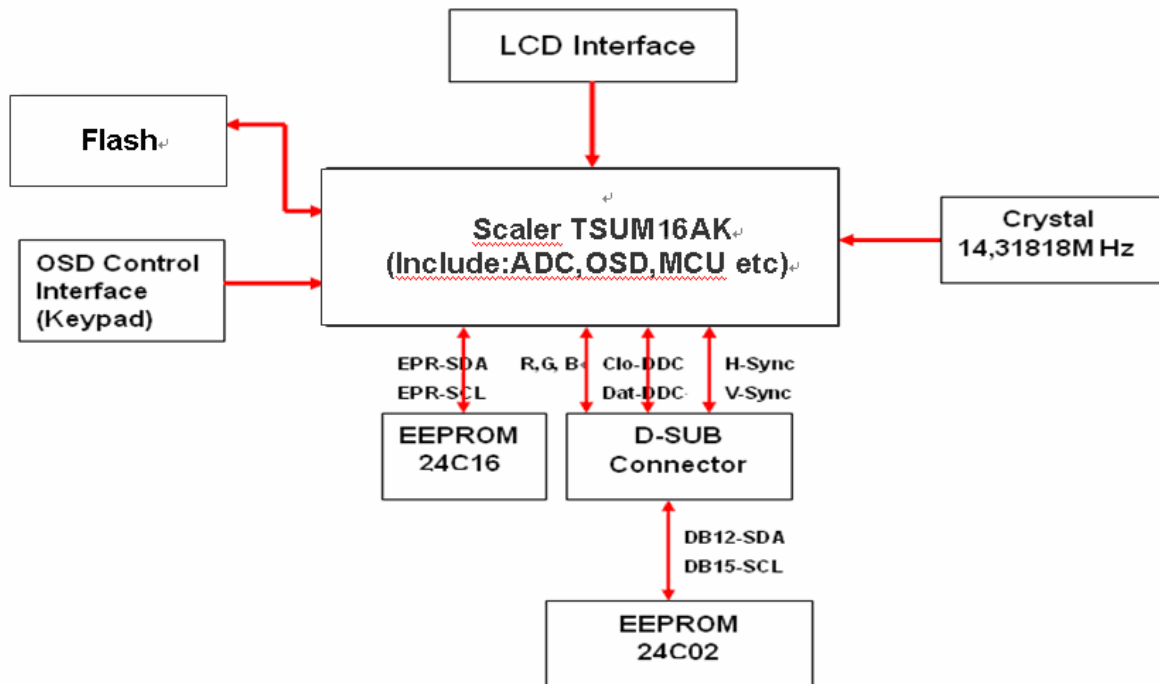

11. Schematic Diagram

11.1 Top

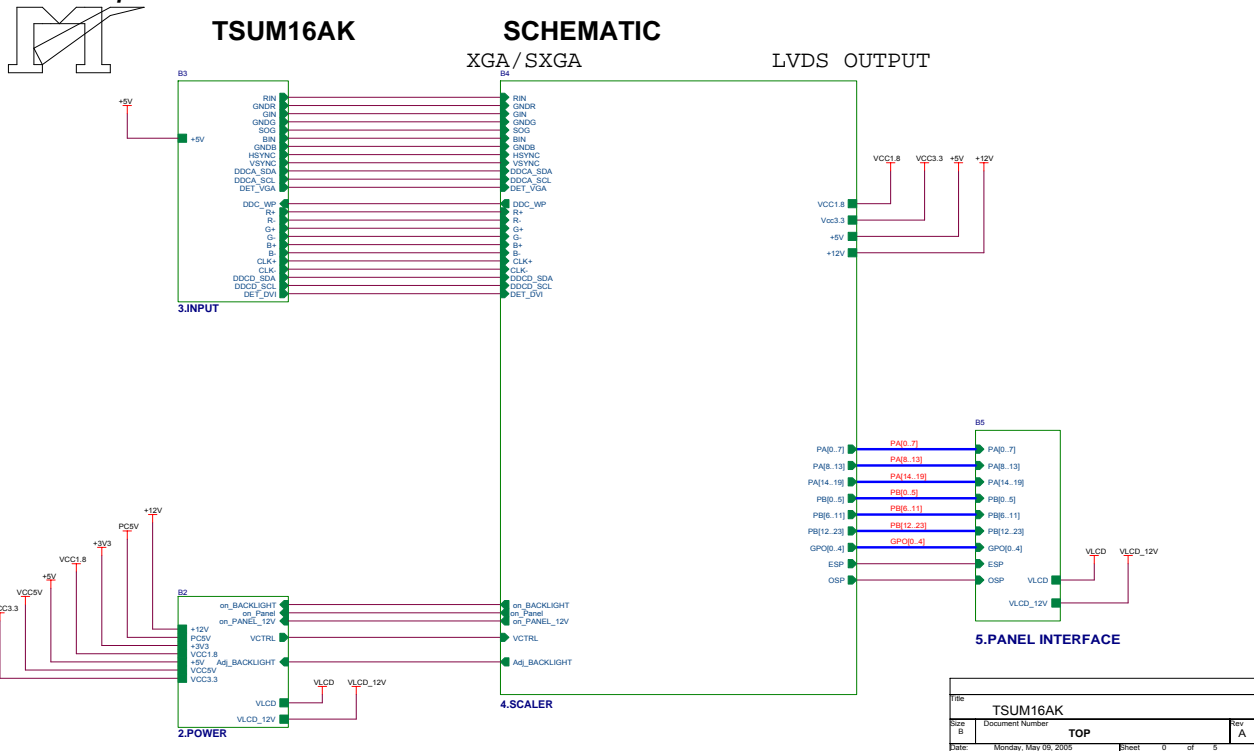

11.2 Power

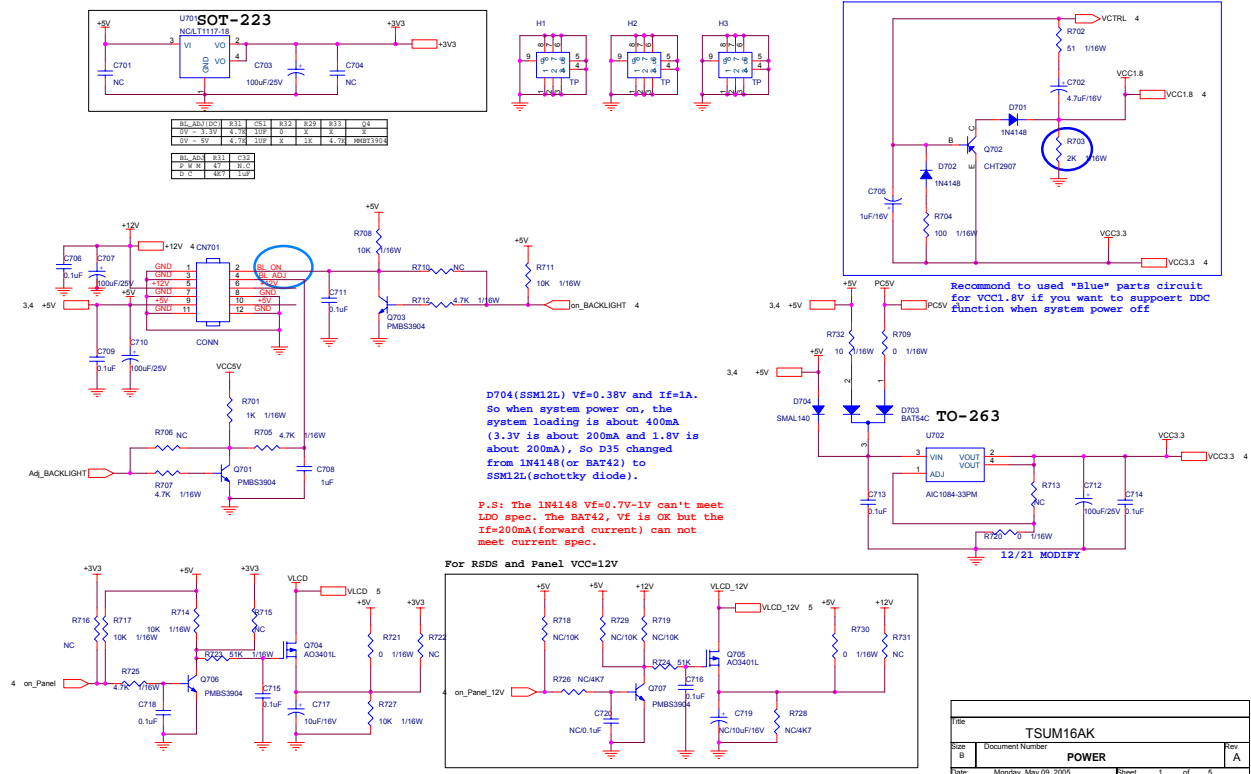

Title		TSUM16AK	
Doc No	Document Number	POWER	
Date	Monday, May 09, 2005	Sheet	1 of 5
		Rev	A

11.3 Input

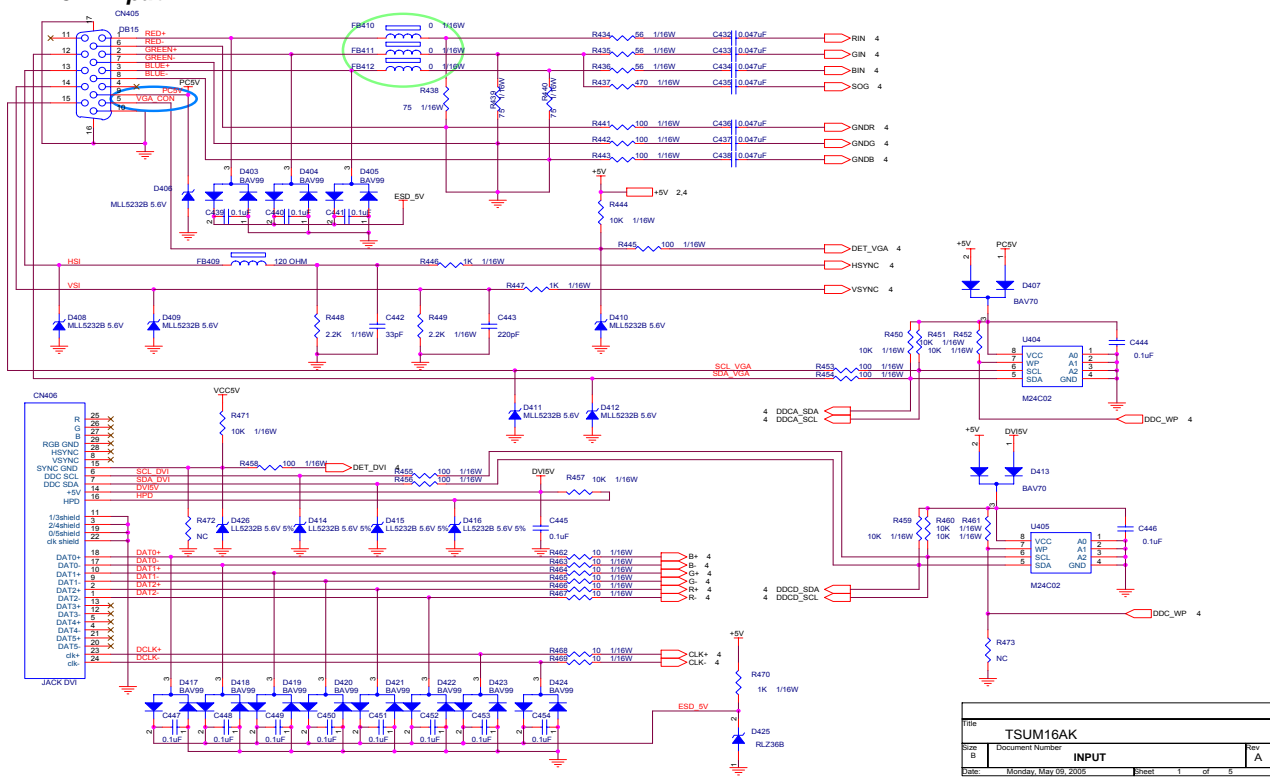

Part	TSUM16AK		Rev
Size	Document Number	INPUT	A
Date:	Monday, May 09, 2005	Sheet	1 of 5

11.4 Scaler

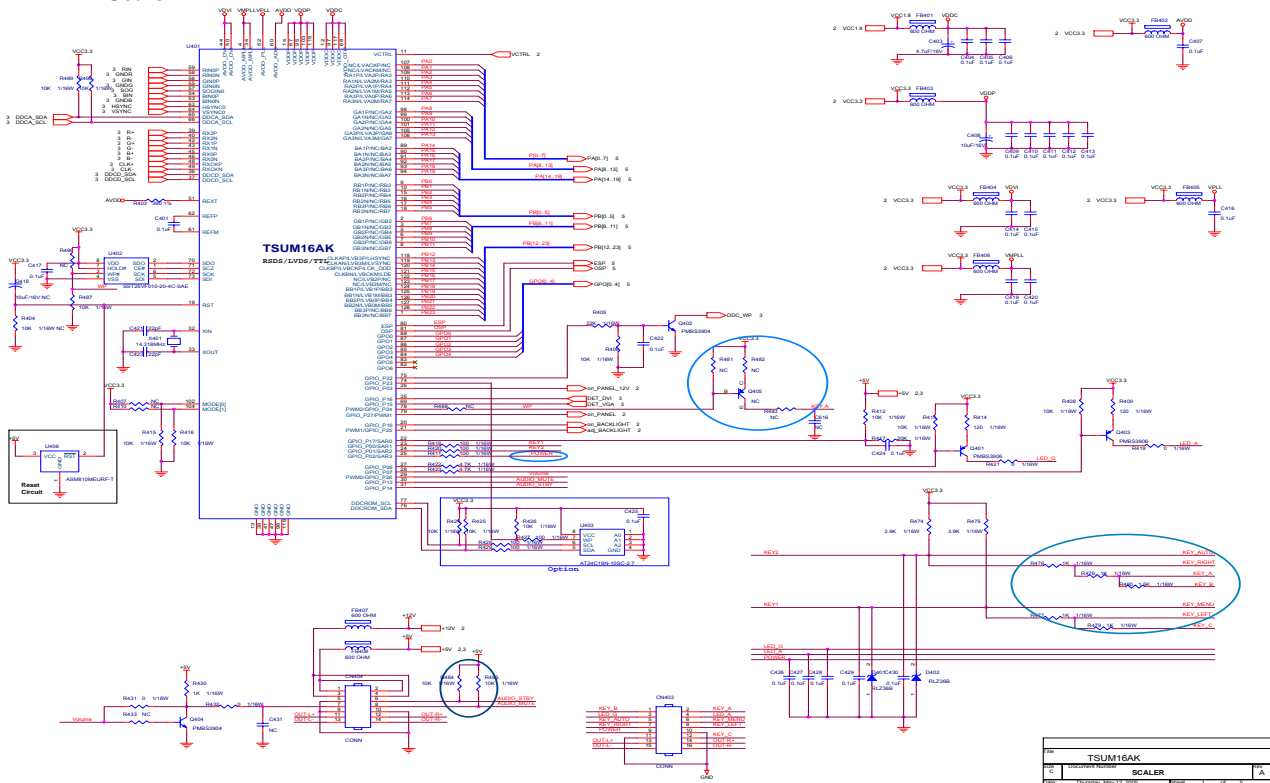

11.5 Panel Interface

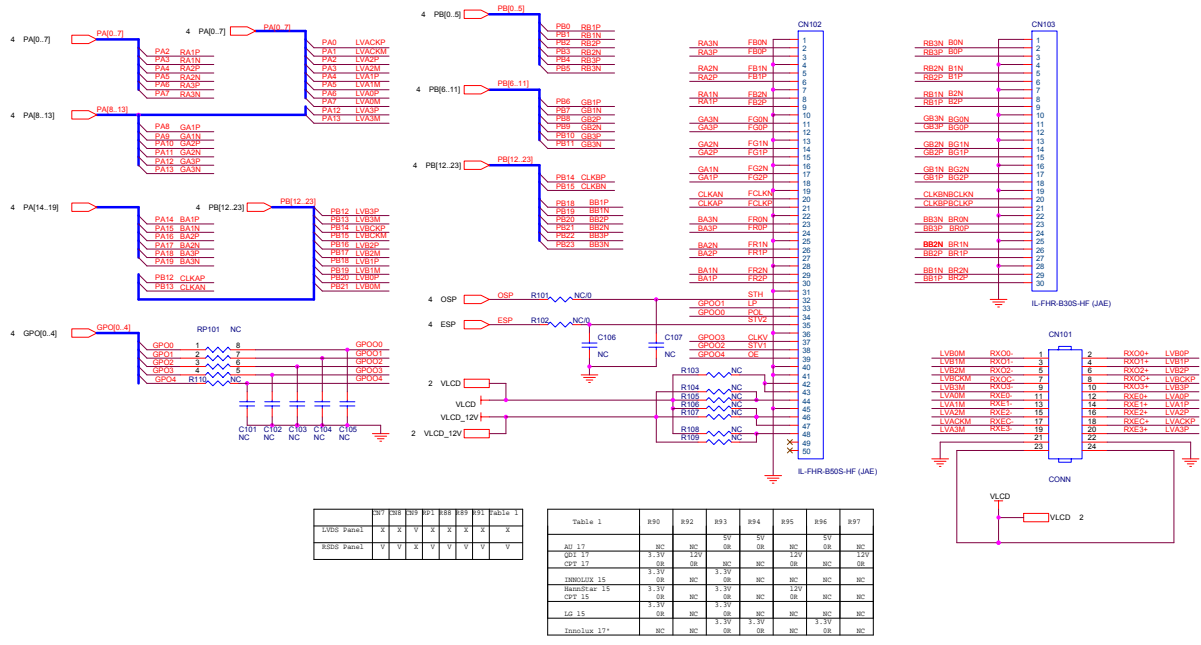

	837	838	839	841	844	847	848	849	850	851	852	853	854	855	856	857
LVDS Panel1	X	X	X	V	X	X	X	X	X	X	X	X	X	X	X	X
ESDP Panel1	V	V	V	X	V	V	V	V	V	V	V	V	V	V	V	V

Table 1	830	832	833	834	835	836	837
AB 17	NC	NC	NC	OV	OV	NC	OV
GD 14	3.3V	3.3V	3.3V	3.3V	3.3V	3.3V	3.3V
CPT 17	OV	OV	NC	NC	OV	NC	OV
ENHOLUX 15	OV	NC	OV	NC	NC	NC	NC
Modulux 15	3.3V	3.3V	3.3V	3.3V	3.3V	3.3V	3.3V
CPT 15	OV	NC	OV	NC	OV	NC	OV
Ld 15	OV	NC	OV	NC	NC	NC	NC
Modulux 17*	NC	NC	OV	OV	OV	OV	OV

Doc		TSM16AK	
Size	Document Number	PANEL INTERFACE	
Date	Monday, May 09, 2005	Sheet	1 of 5

11.6 Inverter

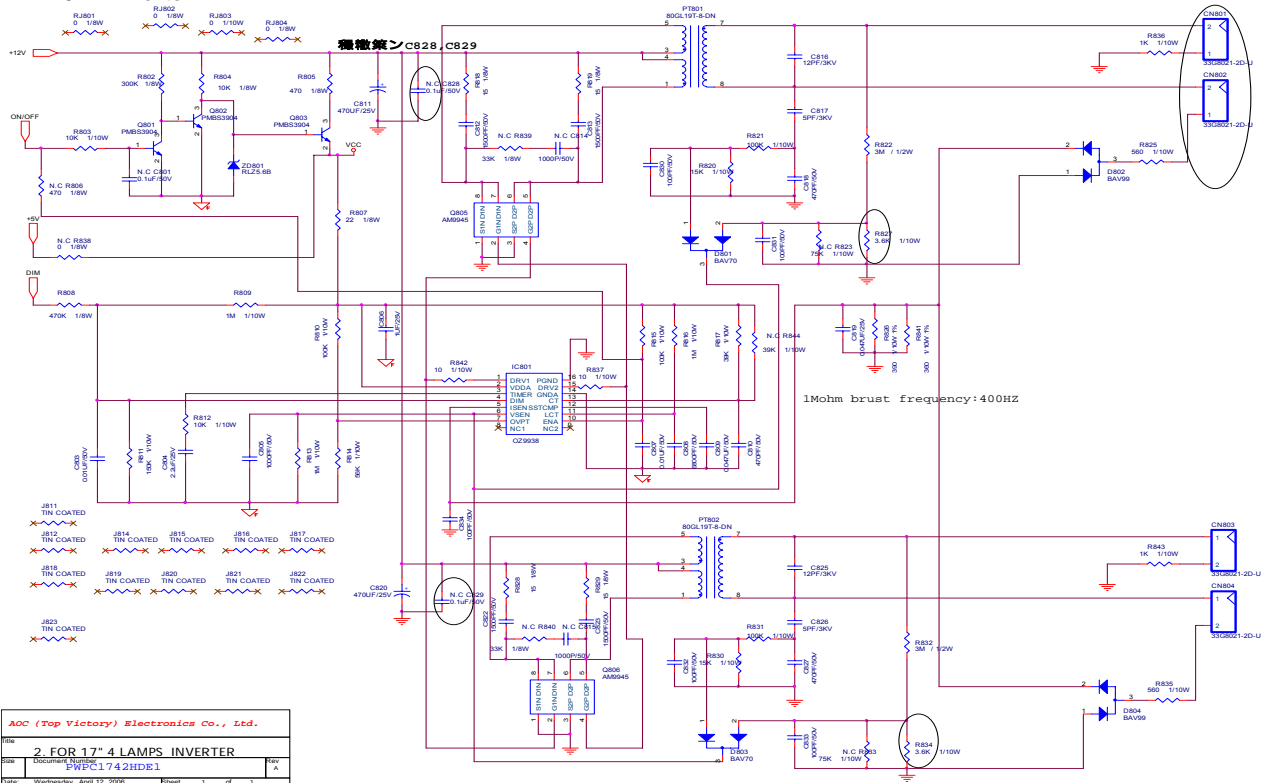

AOC (Top Victory) Electronics Co., Ltd.			
Item	2 FOR 17" 4 LAMPS INVERTER		
Rev	Document No.	PWPC1742HDE1	
Date	Wednesday, April 12, 2006	Sheet	1 of 1

11.7 A-D Power

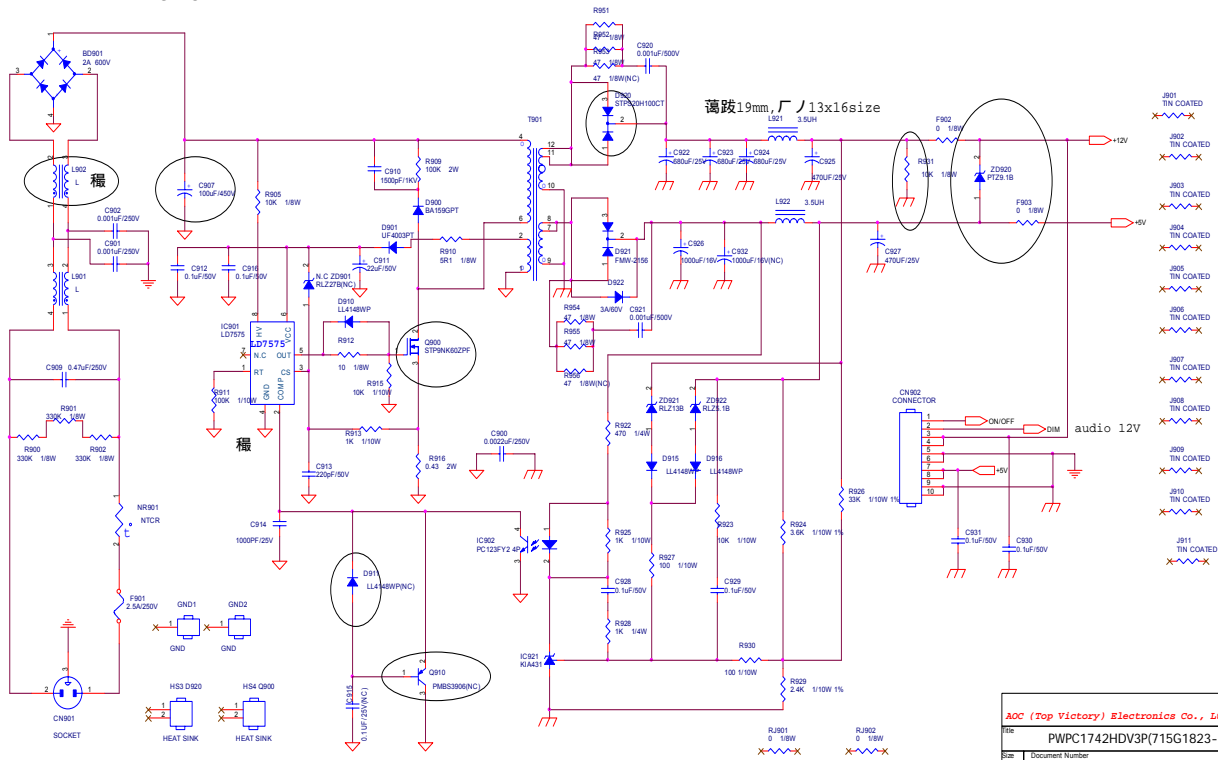

AOC (Top Victory) Electronics Co., Ltd.		
PWPC1742HDV3P(715G1823-N)		
Doc	Document Number	Rv
Rev	Customer	A
Date: Wednesday, April 12, 2006	Sheet	1 of 1

11.8 Audio

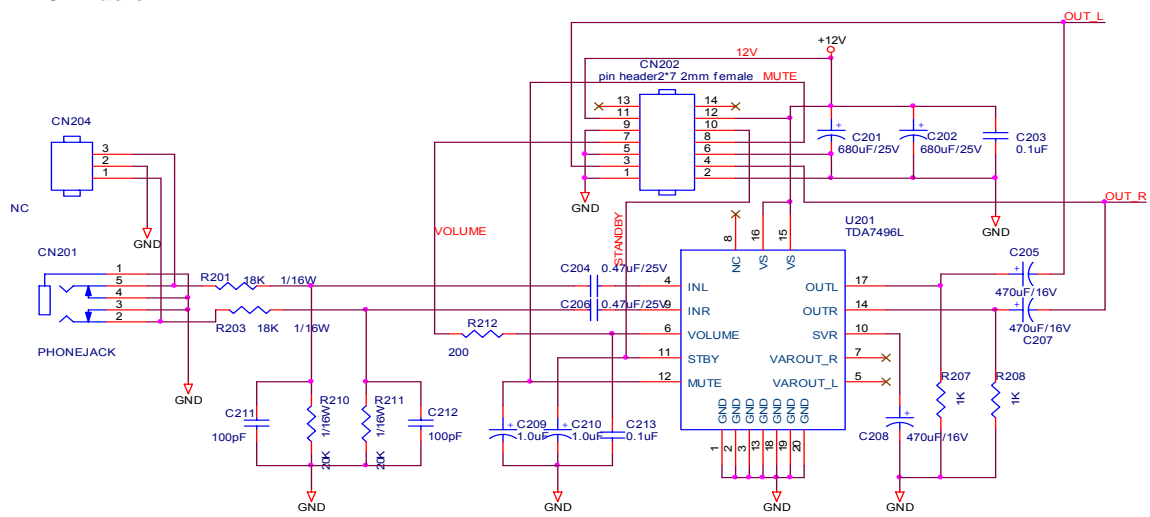

Title		
Audio		
Size	Document Number	Rev
A	<Doc>	<Rev Code>
Date:	Tuesday, March 21, 2006	Sheet 7 of 8

11.9 Key Pad

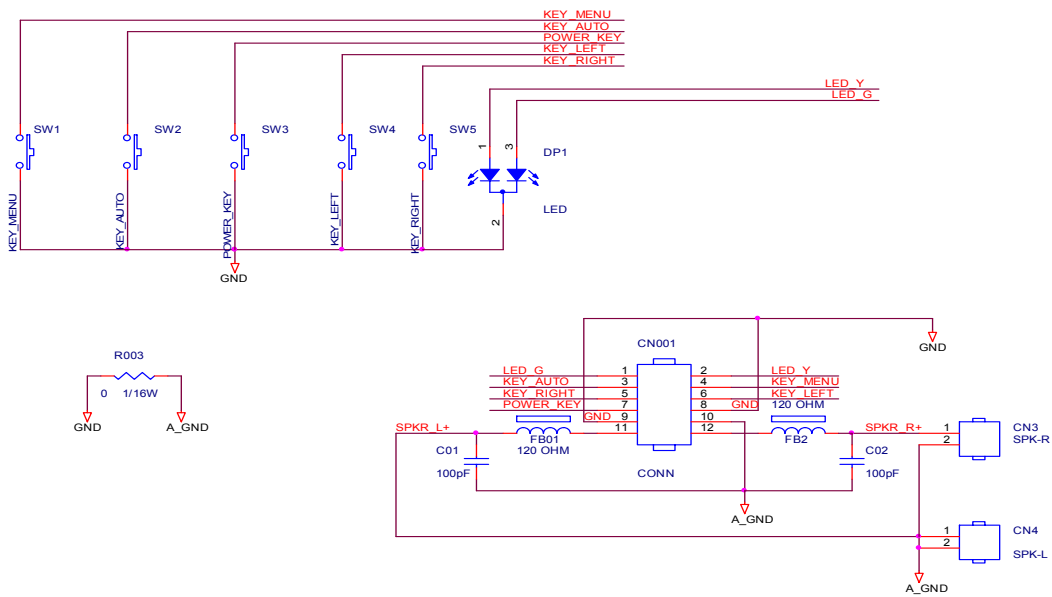

AOC (Top Victory) Electronics Co., Ltd.

Title		
KEY PAD		
Size	Document Number	Rev
A		B
Date:	Tuesday, March 21, 2006	Sheet 8 of 8

12.2 MAIN BOARD PCB BUTTON VIEW

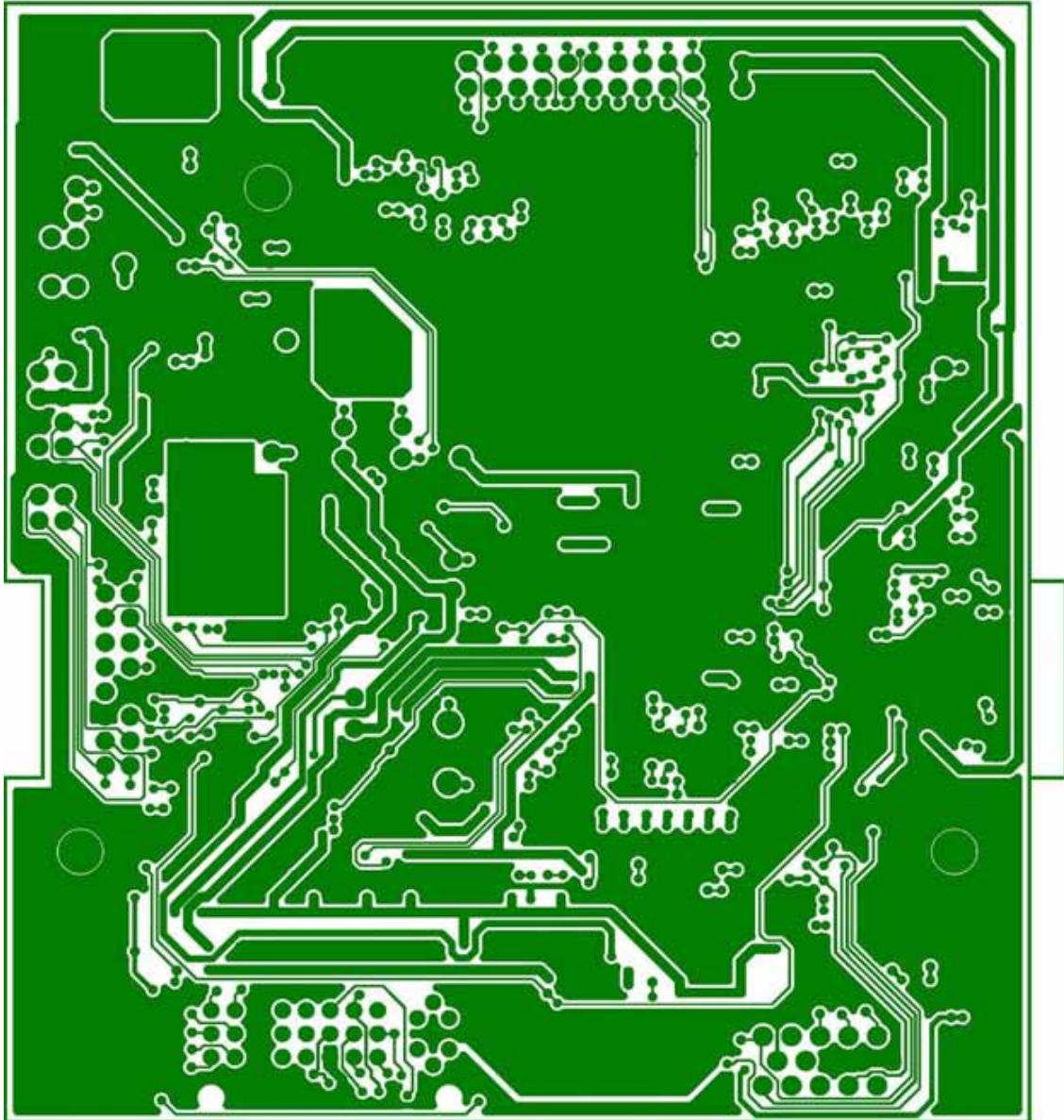

12.3 POWER PCB TOP VIEW

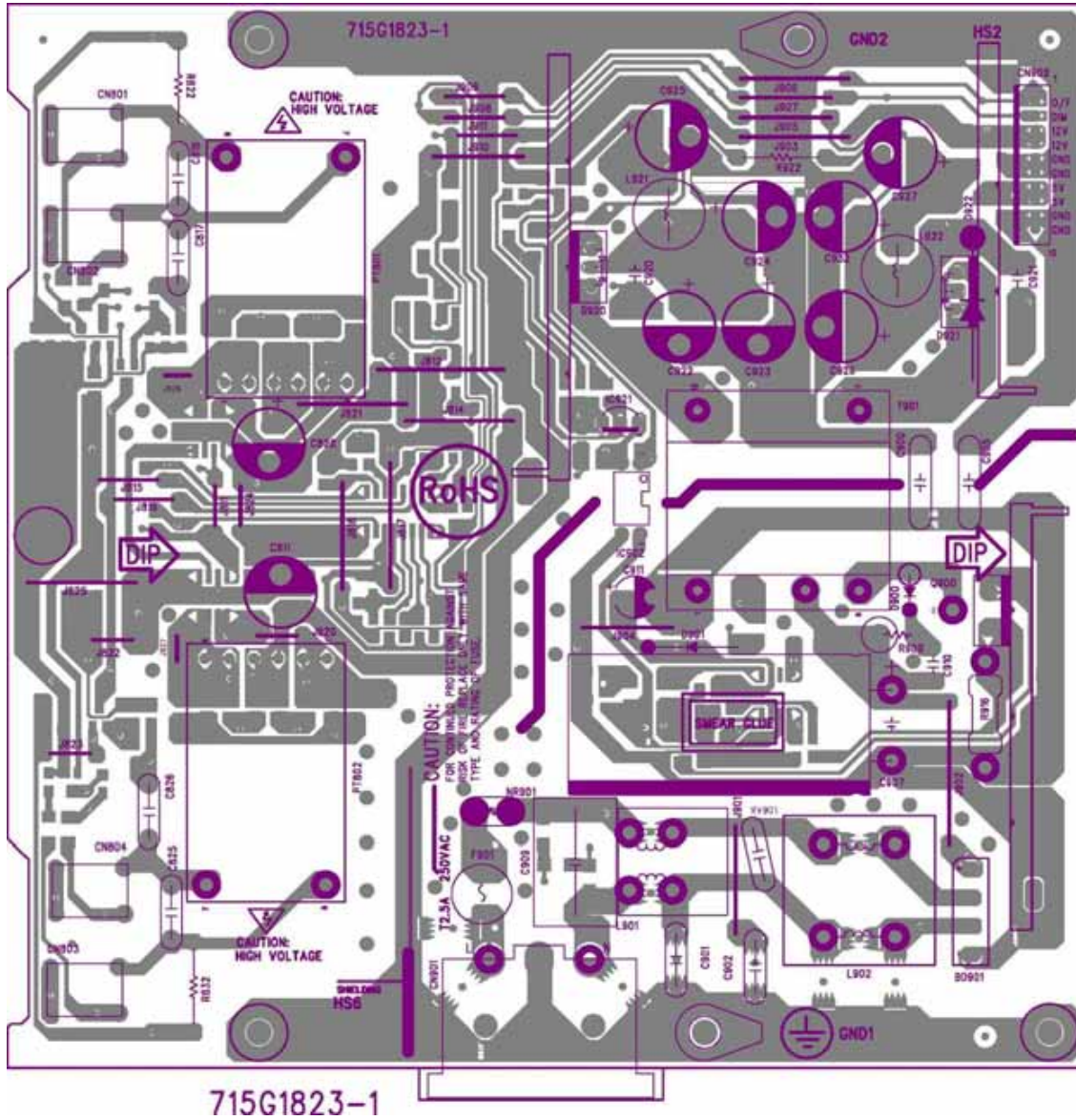

12.4 POWER PCB BUTTON VIEW

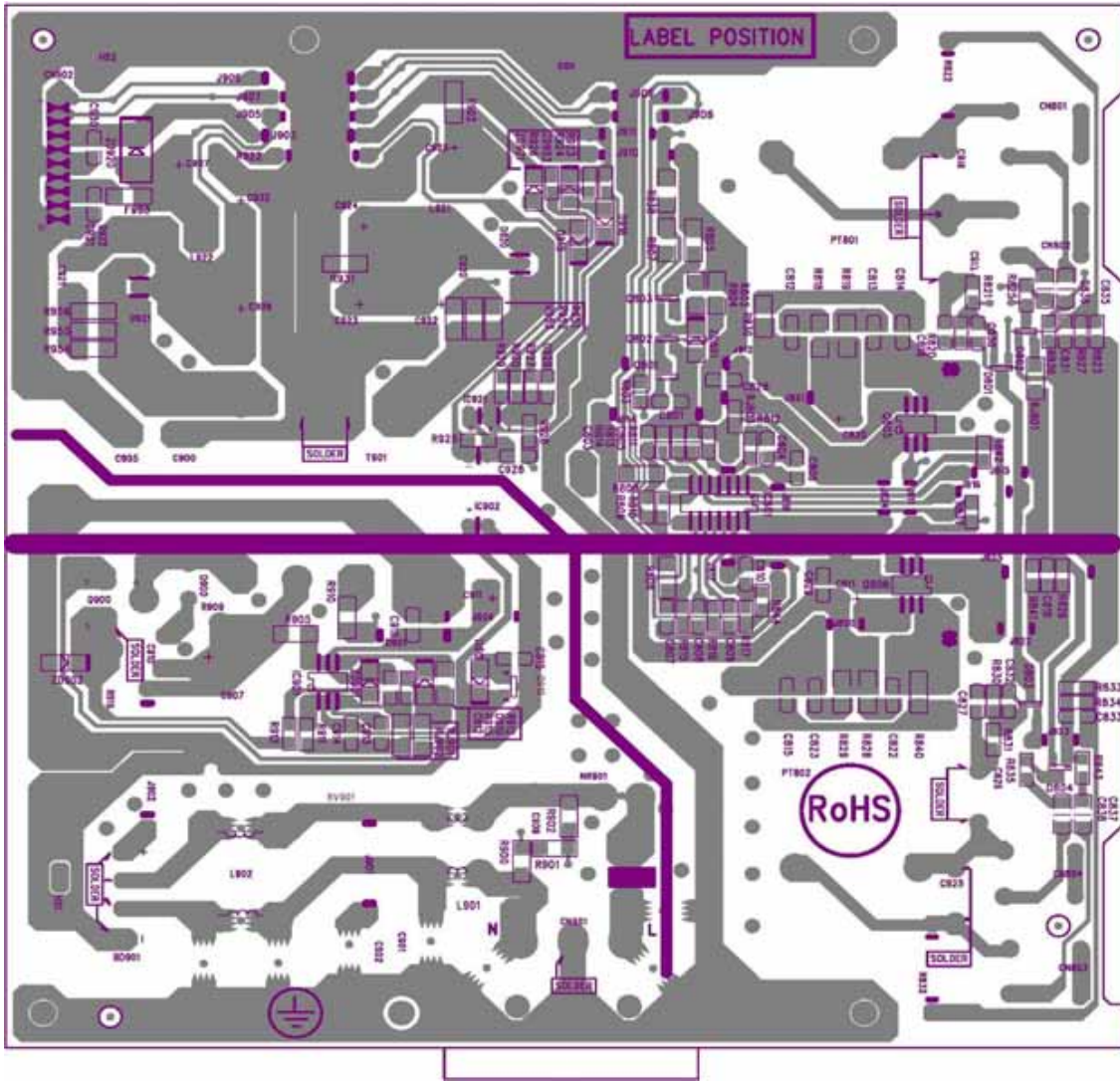

12.7 AUDIO PCB TOP VIEW & BUTTON VIEW

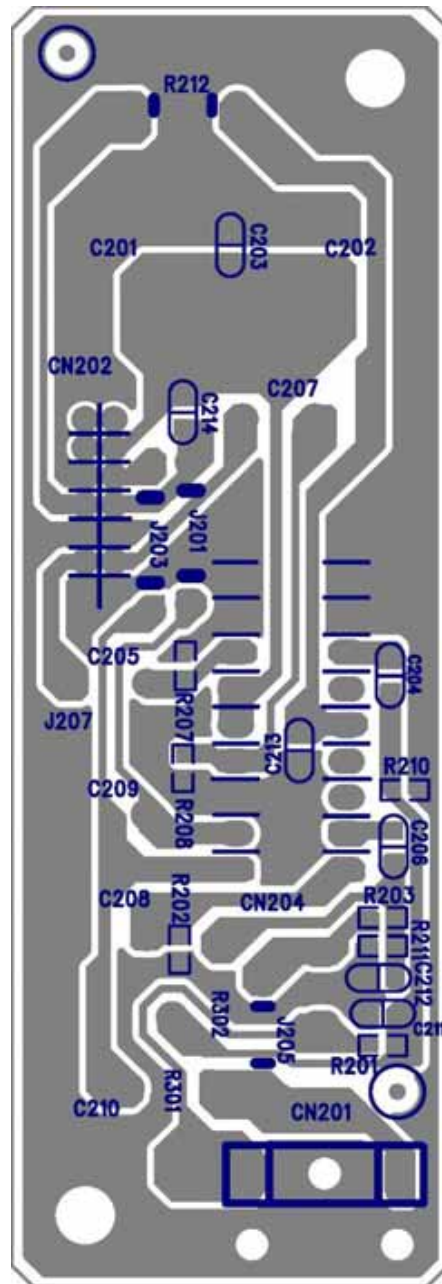
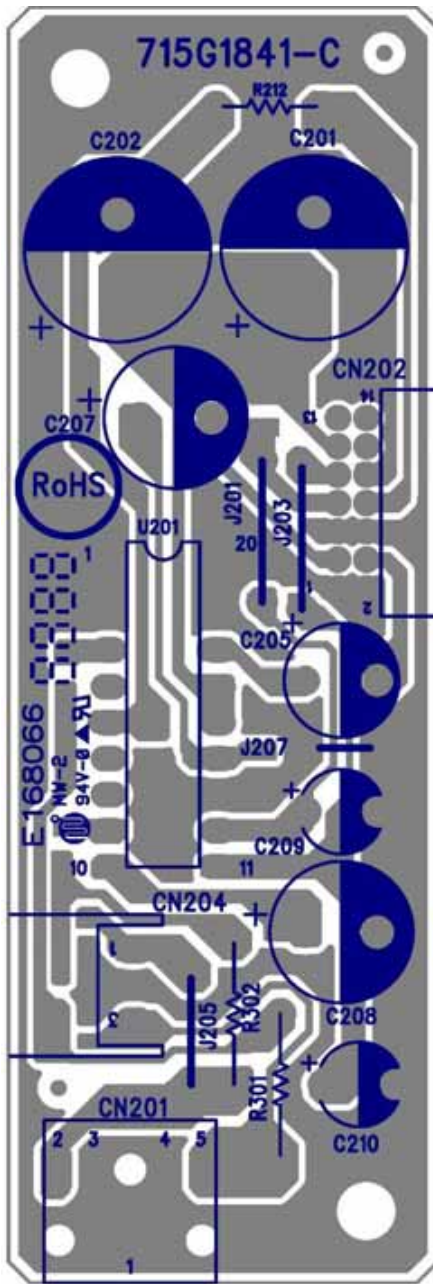

* Reader's Response *

Dear Readers:

Thank you in advance for your feedback on our Service Manual, which allows continuous improvement of our products. We would appreciate your completion of the Assessment Matrix below, for return to ViewSonic Corporation.

Assessment

A. What do you think about the content after reading **VA703b/VA703m** Service Manual?

Unit	Excellent	Good	Fair	Bad
1. Precautions And Safety Notice				
2. Specification				
3. Front Panel Control and Indicators				
4. Circuit Description				
5. Adjustment Procedure				
6. Troubleshooting Flow Chart				
7. Recommended Spare Parts List				
8. Exploded Diagram And Spare Parts List				
9. Block Diagram				
10. Schematic Diagram				
11. PCB Layout Diagram				

B. Are you satisfied with the **VA703b/VA703m** Service Manual?

Item	Excellent	Good	Fair	Bad
1. Service Manual Content				
2. Service Manual Layout				
3. The form and listing				

C. Do you have any opinion and suggestion about this Service Manual?

Reader's Basic Data:

Name:		Title:	
Company:			
Add:			
Tel:		Fax :	
E-Mail:			

After completing this form, please return it to ViewSonic Quality Assurance in the USA at facsimile 1-909-839-7943. You may also e-mail any suggestion to the Director, Quality System & Process (marc.maupin@viewsonic.com)