

Service
Service
Service



Service Manual



TABLE OF CONTENTS

	Chapter
Location Of PCB Boards	1-2
Versions Variation	1-2
Specifications	1-3
Measurement Setup	1-6
Service Aids	1-7
ESD & Safety Instruction	1-8
Lead-free Soldering Information	1-9
Setting Procedure & Repair Instructions	2
Disassembly Instructions & Service Positions	3
Block & Wiring Diagram	4
Diagram Quick Start Guide	5
Main+VFD+FR+FL+MP3+WIFI+Open+Clos+RFS Board..	6
Power & AMP Board	7
BD Board.....	8
Touch Board	9
Mechanical Exploded View.....	10
Revision List	11

© Copyright 2011 Philips Consumer Electronics B.V. Eindhoven, The Netherlands
 All rights reserved. No part of this publication may be reproduced, stored in a retrieval system or transmitted, in any form or by any means, electronic, mechanical, photocopying, or otherwise without the prior permission of Philips.

Published by RY_RLYF 1125 Service Audio Printed in The Netherlands Subject to modification

GB 3139 785 35752

Version 1.2



PHILIPS

LOCATION OF PCB BOARDS

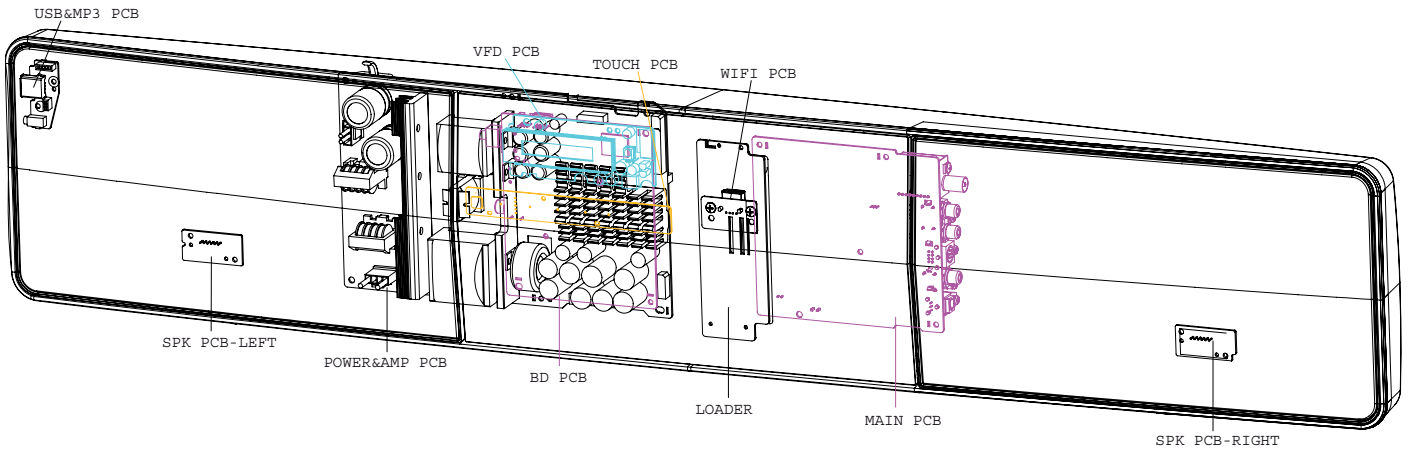

VERSION VARIATION:

Type/Versions	HTS5131		
	/12	/98	/51
Features			
Output Power - 400W	X	X	X
Voltage (220~240V)	X	X	X
Voltage (110~127V)		X	
Music iLink	X	X	X

SERVICE SCENARIO MATRIX:

Type/Versions	HTS5131		
	/12	/98	/51
Board in used			
Main+VFD+FR+FL+MP3+WIFI+Open+CLOS+RFS Board	C	C	C
Power & AMP Board	C	C	C
Touch Board	Bd	C	C
BD Board	Bd	Bd	Bd

*Bd= Board Level Replacement

*C = Component Level Repair

SPECIFICATIONS

Media formats

- AVCHD, BD-RE, BD-Video, DVD-Video, DVD+R/RW, DVD-R/RW, DVD+R/-R DL, CD-R/CD-RW, Audio CD, Video CD/SVCD, Picture files, MP3-CD, WMA-CD, DivX (Ultra)-CD, USB storage device

File formats

- Audio: .aac, .mka, .mp3, .wma, .wav
- Video: .avi, .divx, .mp4, .mkv, .asf, .mpg, .mpeg
- Picture: .jpg, .jpeg, .gif, .png

Audio formats

Your home theater supports the following audio files.

Extension	Container	Audio codec	Bit rate
.mp3	MP3	MP3	32 kbps ~ 320 kbps
.wma	ASF	WMA	64 kbps ~ 160 kbps
.aac	AAC	AAC, HE-AAC	192 kbps
.wav	WAV	PCM	1.4 Mbps
.m4a	MKV	AAC	192 kbps
.mka	MKA	PCM	27.648 Mbps
.mka	MKA	Dolby Digital	640 kbps
.mka	MKA	DTS core	1.54 Mbps
.mka	MKA	MPEG	912 kbps
.mka	MKA	MP3	32 kbps ~ 320 kbps
.mka	MKA	WMA	64 kbps ~ 160 kbps
.mka	MKA	AAC, HE-AAC	192 kbps

Video formats

If you have a high definition TV, your home theater allows you to play your video files with:

- Resolution: 1920 x 1080 pixels at
- Frame rate: 6 ~ 30 frames per second.

.avi files in AVI container

Audio codec	Video codec	Bit rate
PCM, Dolby Digital, DTS core, MP3, WMA	DivX 3.11, DivX 4.x, DivX 5.x, DivX 6.x	10 Mbps max
	MPEG 1, MPEG 2	20 Mbps (peak 40 Mbps)
	MPEG 4 ASP	10 Mbps max
	H.264/AVC HP@4.1/4.0; MP@3.2/3.1/3.0	20 Mbps (peak 40 Mbps)

.divx files in AVI container

Audio codec	Video codec	Bit rate
PCM, Dolby Digital, MP3, WMA	DivX 3.11, DivX 4.x, DivX 5.x, DivX 6.x	10 Mbps max
	MPEG 1, MPEG 2	20 Mbps (peak 40 Mbps)
	MPEG 4 ASP	10 Mbps max

.mp4 or .m4v files in MP4 container

Audio codec	Video codec	Bit rate
Dolby Digital, MPEG, MP3, AAC, HE-AAC	MPEG 1, MPEG 2	20 Mbps (peak 40 Mbps)
	MPEG 4 ASP	10 Mbps max
	H.264/AVC HP@4.1/4.0; MP@3.2/3.1/3.0	20 Mbps (peak 40 Mbps)

.mkv files in MKV container

Audio codec	Video codec	Bit rate
PCM, Dolby Digital, DTS core, MPEG, MP3, WMA, AAC, HE-AAC	MPEG 1, MPEG 2	20 Mbps (peak 40 Mbps)
	MPEG 4 ASP	10 Mbps max
	H.264/AVC HP@4.1/4.0; MP@3.2/3.1/3.0	20 Mbps (peak 40 Mbps)

.asf files in ASF container

Audio codec	Video codec	Bit rate
PCM, Dolby Digital, MP3, WMA	MPEG 4 ASP	10 Mbps max
	H.264/AVC HP@4.1/4.0; MP@3.2/3.1/3.0	20 Mbps (peak 40 Mbps)

.mpg and .mpeg files in PS container

Audio codec	Video codec	Bit rate
PCM, DTS core, MPEG, MP3	MPEG 1, MPEG 2	20 Mbps (peak 40 Mbps)
	MPEG 1, MPEG 2	20 Mbps (peak 40 Mbps)

Amplifier

- Total output power: 400W RMS (30% THD)/ 300W RMS (10% THD)
- Frequency response: 20 Hz-20 kHz / ± 3 dB
- Signal-to-noise ratio: > 65 dB (CCIR) / (A-weighted)
- Input sensitivity:
 - AUX : 500 mV
 - Music iLink: 250 mV

Video

- Signal system: PAL / NTSC
- HDMI output: 480i/576i, 480p/576p, 720p, 1080i, 1080p, 1080p24

USB

- Compatibility: Hi-Speed USB (2.0)
- Class support: USB Mass Storage Class (MSC)
- Filesystem: FAT16, FAT32, NTFS
- Maximum memory support: < 160 GB

Main unit

- Power supply:
 - Europe /China: 220-240 V~, 50 Hz
 - Latin America/Asia Pacific: 110-127 V/220-240 V~, 50-60 Hz
 - Russia/India: 220-240 V~, 50 Hz
- Power consumption: 75 W
- Standby power consumption: ≤ 0.3 W
- Left/Right speakers:
 - Speaker impedance: 6 ohm
 - Speaker drivers: 2 x 64 mm (2.5" woofer + 1 x 25 mm (1" tweeter
 - Frequency response: 150 Hz-20 kHz
- Dimensions (W xHxD): 945 x 178.5 x 96mm
- Weight: 5.0 kg

Audio

- S/PDIF Digital audio input:
 - Coaxial: IEC 60958-3
 - Optical: TO SLINK
- Sampling frequency:
 - MP3: 32 kHz, 44.1 kHz, 48 kHz
 - WMA: 44.1 kHz, 48 kHz
- Constant bit rate:
 - MP3: 32 kbps - 320 kbps
 - WMA: 48 kbps - 192 kbps

Radio

- Tuning range:
 - Europe /China: FM 87.5-108 MHz (50 kHz)
 - Asia Pacific/Russia/Latin America: FM 87.5-108 MHz (50/100 kHz)
- Signal-to-noise ratio: FM 50 dB
- Frequency response: FM 180 Hz-12.5 kHz / ± 3 dB

Subwoofer

- Power output: 200W RMS (30% THD)/ 150W RMS (10% THD)
- Impedance: 3 ohm
- Speaker drivers: 165 mm (6.5") woofer
- Frequency response: 20 Hz-150 Hz
- Dimensions (W xHxD): 123 x 309 x 369 mm
- Weight: 3.6 kg
- Cable length: 3 m

Wall mount

- Dimensions (W xHxD): 37.6 x 50 x 46.4 mm
- Weight: 0.05 kg/each

Remote control batteries

- 2 x AAA-R03-1.5 V

Laser

- Laser Type (Diode): InGaN/AlGaIn (BD), AlGaInP (DVD/CD)
- Wave length: 405 +7 nm/-7 nm (BD), 655 +10 nm/-10 nm (DVD), 790 +10 nm/-20 nm (CD)
- Output power (Max. ratings): 20 mW (BD), 6 mW (DVD), 7 mW (CD)

Specifications subject to change without prior notice.

MEASUREMENT SETUP

Tuner FM

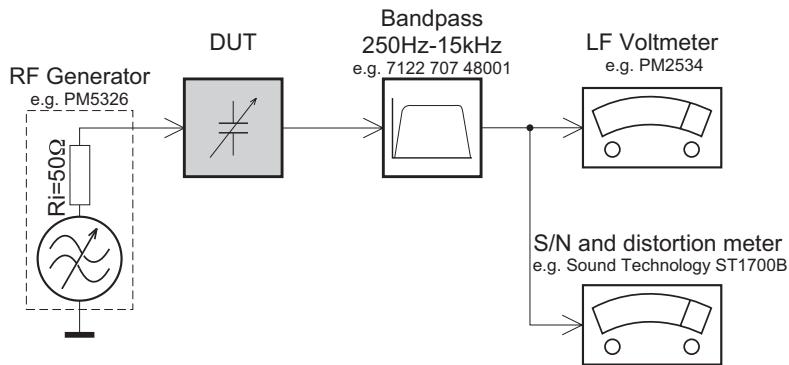

Use a bandpass filter to eliminate hum (50Hz, 100Hz) and disturbance from the pilotone (19kHz, 38kHz).

CD

Use Audio Signal Disc SBC429 4822 397 30184
(replaces test disc 3)

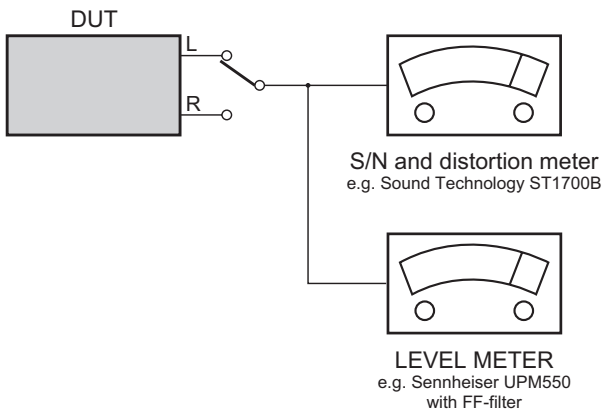

SERVICE AIDS

Service Tools:

- Universal Torx driver holder4822 395 91019
- Torx bit T10 150mm4822 395 50456
- Torx driver set T6-T204822 395 50145
- Torx driver T10 extended4822 395 50423

Compact Disc:

- SBC426/426A Test disc 5 + 5A4822 397 30096
- SBC442 Audio Burn-in test disc 1kHz4822 397 30155
- SBC429 Audio Signals disc4822 397 30184
- Dolby Pro-logic Test Disc4822 395 10216

HANDLING CHIP COMPONENTS

GENERAL

SOLDER
CHIP COMPONENT
SOLDER
COPPER TRACK
P.C.B.
GLUE

SERVICE PACKAGE

DISMOUNTING

VACUUM PISTON
4822 395 10082

SOLDERING IRON
e.g. WELLER solder tip PT-H7

SOLDERING IRON
SOLDER WICK
4822 321 40042

e.g. A PAIR OF TWEEZERS

HEATING HEATING

SOLDERING IRON
SOLDER WICK
CLEANING

PRECAUTIONS

SOLDERING IRON
CORRECT
COPPER TRACK

SOLDERING IRON
CORRECT
CHIP COMPONENT

MOUNTING

e.g. A PAIR OF TWEEZERS

SOLDERING IRON
SOLDER ø0.5-0.8mm
PRESSURE

SOLDERING TIME < 3 sec/side

SOLDER ø0.5-0.8mm
PRESSURE
SOLDERING IRON

EXAMPLES

CORRECT

SOLDERING IRON
NO!

ESD**GB WARNING**

All ICs and many other semi-conductors are susceptible to electrostatic discharges (ESD). Careless handling during repair can reduce life drastically.

When repairing, make sure that you are connected with the same potential as the mass of the set via a wrist wrap with resistance. Keep components and tools also at this potential.

F ATTENTION

Tous les IC et beaucoup d'autres semi-conducteurs sont sensibles aux décharges statiques (ESD).

Leur longévité pourrait être considérablement écourtée par le fait qu'aucune précaution n'est prise à leur manipulation.

Lors de réparations, s'assurer de bien être relié au même potentiel que la masse de l'appareil et enfilez le bracelet serti d'une résistance de sécurité.

Veiller à ce que les composants ainsi que les outils que l'on utilise soient également à ce potentiel.

D WARNUNG

Alle ICs und viele andere Halbleiter sind empfindlich gegenüber elektrostatischen Entladungen (ESD).

Unvorsichtige Behandlung im Reparaturfall kann die Lebensdauer drastisch reduzieren. Veranlassen Sie, dass Sie im Reparaturfall über ein Pulsarmband mit Widerstand verbunden sind mit dem gleichen Potential wie die Masse des Gerätes. Bauteile und Hilfsmittel auch auf dieses gleiche Potential halten.

NL WAARSCHUWING

Alle IC's en vele andere halfgeleiders zijn gevoelig voor electrostatische ontladingen (ESD).

Onzorgvuldig behandelen tijdens reparatie kan de levensduur drastisch doen verminderen. Zorg ervoor dat u tijdens reparatie via een polsband met weerstand verbonden bent met hetzelfde potentiaal als de massa van het apparaat.

Houd componenten en hulpmiddelen ook op ditzelfde potentiaal.

I AVVERTIMENTO

Tutti IC e parecchi semi-conduttori sono sensibili alle scariche statiche (ESD).

La loro longevità potrebbe essere fortemente ridotta in caso di non osservazione della più grande cauzione alla loro manipolazione. Durante le riparazioni occorre quindi essere collegato allo stesso potenziale che quello della massa dell'apparecchio tramite un braccialetto a resistenza.

Assicurarsi che i componenti e anche gli utensili con quali si lavora siano anche a questo potenziale.

GB ESD PROTECTION EQUIPMENT

Complete Kit ESD3 (small tablemat, wristband, connection box, estention cable and earth cable 4822 310 10671
Wristband tester 4822 344 13999

GB

Safety regulations require that the set be restored to its original condition and that parts which are identical with those specified, be used.

Safety components are marked by the symbol Δ .

NL

Veiligheidsbepalingen vereisen, dat het apparaat bij reparatie in zijn oorspronkelijke toestand wordt teruggebracht en dat onderdelen, identiek aan de gespecificeerde, worden toegepast.

De Veiligheidsonderdelen zijn aangeduid met het symbol Δ .

F

Les normes de sécurité exigent que l'appareil soit remis à l'état d'origine et que soient utilisés les pièces de rechange identiques à celles spécifiées.

Less composants de sécurité sont marqués Δ .

D

Bei jeder Reparatur sind die geltenden Sicherheitsvorschriften zu beachten. Der Originalzustand des Geräts darf nicht verändert werden; für Reparaturen sind Original-Ersatzteile zu verwenden.

Sicherheitsbauteile sind durch das Symbol Δ markiert.

I

Le norme di sicurezza esigono che l'apparecchio venga rimesso nelle condizioni originali e che siano utilizzati i pezzi di ricambio identici a quelli specificati.

Componenti di sicurezza sono marcati con Δ .

GB

After servicing and before returning set to customer perform a leakage current measurement test from all exposed metal parts to earth ground to assure no shock hazard exist, The leakage current must not exceed 0.5mA.

**GB Warning !**

Invisible laser radiation when open.
Avoid direct exposure to beam.

S Varning !

Osynlig laserstrålning när apparaten är öppnad och spårren är urkopplad. Betrakta ej strålen.

SF Varoitus !

Avatussa laitteessa ja suojalukituksen ohitettaessa olet alttiina näkymättömälle laserisäteilylle. Älä katso säteeseen!

DK Advarse !

Usynlig laserstrålning ved åbning når sikkerhedsafbrydere er ude af funktion. Undgå udsættelse for strålning.

F

"Pour votre sécurité, ces documents doivent être utilisés par des spécialistes agréés, seuls habilités à réparer votre appareil en panne".

Pb(Lead) Free Solder

When soldering, be sure to use the pb free solder.

IDENTIFICATION:

Regardless of special logo (not always indicated)



one must treat all sets from **1 Jan 2005** onwards, according next rules:

Important note: In fact also products of year 2004 must be treated in this way as long as you avoid mixing solder-alloys (leaded/ lead-free). So best to always use SAC305 and the higher temperatures belong to this.

Due to lead-free technology some rules have to be respected by the workshop during a repair:

- Use only lead-free solder alloy Philips SAC305 with order code 0622 149 00106. If lead-free solder-paste is required, please contact the manufacturer of your solder-equipment. In general use of solder-paste within workshops should be avoided because paste is not easy to store and to handle.
- Use only adequate solder tools applicable for lead-free solder alloy. The solder tool must be able
 - To reach at least a solder-temperature of 400°C,
 - To stabilize the adjusted temperature at the solder-tip
 - To exchange solder-tips for different applications.
- Adjust your solder tool so that a temperature around 360°C – 380°C is reached and stabilized at the solder joint. Heating-time of the solder-joint should not exceed ~ 4 sec. Avoid temperatures above 400°C otherwise wear-out of tips will rise drastically and flux-fluid will be destroyed. To avoid wear-out of tips switch off unused equipment, or reduce heat.
- Mix of lead-free solder alloy / parts with leaded solder alloy / parts is possible but PHILIPS recommends strongly to avoid mixed solder alloy types (leaded and lead-free).
If one cannot avoid or does not know whether product is lead-free, clean carefully the solder-joint from old solder alloy and re-solder with new solder alloy (SAC305).
- Use only original spare-parts listed in the Service-Manuals. Not listed standard-material (commodities) has to be purchased at external companies.
- Special information for BGA-ICs:
 - Always use the 12nc-recognizable soldering temperature profile of the specific BGA (for desoldering always use the lead-free temperature profile, in case of doubt)
 - Lead free BGA-ICs will be delivered in so-called 'dry-packaging' (sealed pack including a silica gel pack) to protect the IC against moisture. After opening,

dependent of MSL-level seen on indicator-label in the bag, the BGA-IC possibly still has to be baked dry. (MSL=Moisture Sensitivity Level). This will be communicated via AYS-website.

Do not re-use BGAs at all.

- For sets produced before 1.1.2005 (except products of 2004), containing leaded solder-alloy and components, all needed spare-parts will be available till the end of the service-period. For repair of such sets nothing changes.
- On our website www.atyourservice.ce.Philips.com you find more information to:
 - BGA-de-/soldering (+ baking instructions)
 - Heating-profiles of BGAs and other ICs used in Philips-sets

You will find this and more technical information within the "magazine", chapter "workshop news".

For additional questions please contact your local repair-helpdesk.

Software upgrade & Procedure to restore product setting

1) Restore factory setting

- Press “” <Home> button on R/C.
- Select <Setup>, then press “OK” button on R/C.
- Select <Advanced>, then press < OK > button on R/C.
- Select <Restore default settings>,then press <OK> to confirm.

2) Password change

- Press “” <Home> button on R/C.
 - Select <Setup>, then press “OK” button on R/C.
 - Select <Preference>, then press <OK> button on R/C.
 - Select <Change Password> <Confirm>, then press <OK> button on R/C.
- “0000” is default password supplied.

3) Trade mode

- In open model,press “” <Home> button on R/C.
- Press “2” “5” “9” on R/C,VFD will display “TRA ON” or “TRA OFF”.

4) Check software version

- Press “” <Home> button on R/C
- Select <Setup>, then press <OK> button on R/C.
- Select <Advanced> <Version Info.>,then press <OK> button on R/C.
- TV will show message as follow:

Model:HTS5131/12/98/51
 Versions:
 System SW:XXX
 Subsystem SW:XX-XX-XX-XX
 Ethernet MAC:XX:XX:XX:XX:XX:XX
<http://www.philips.com/support>

Close

- Select <Close> on the version display screen and press <OK> button to exit .

5) Upgrading new software

- Method 1: Update software from a USB storage device
- Create a folder named “UPG_ALL” in your USB storage device, and Copy the latest upgrading software into the folder.
 - Connect the USB storage device to the home theater.
 - Press “” <Home> button on R/C, and select <Setup>.
 - Select <Advanced> <Software Update> <USB>.
 - TV will show message as follow:

Now searching for upgrade software!
Please wait...!

Software updates for this player have been found. Do you want to upgrade?

Cancel

Start

- Select <Start>, press <OK> button on R/C.

Software upgrade will take 5 minutes

Do not switch off!

Package version: 000025.0

Software BE	80%
Software FE	Completed
Software MCU1:	
Software Dock:	
Software MCU3:	

Software upgrade will take 5 minutes

Do not switch off!

Package version: 000025.0

Software BE	Completed
Software FE	Completed
Software MCU1:	Not started
Software Dock:	2%
Software MCU3:	Not started

Software upgrade will take 5 minutes

Do not switch off!

Package version: 000025.0

Software BE	Completed
Software FE	Completed
Software MCU1:	1%
Software Dock:	Failed
Software MCU3:	

- The set will shut down automatically when the software upgrade is completed.

Method 2: Update software from the internet

Note: To check for new updates, compare the current software version of your home theater with the latest software version (if available) on the Philips web site, and for BD-Live application and software update, make sure that the network router has access to the Internet and the firewall is disabled.

- The “LAN” jack at the back panel of the set must be connect to the network router via network cable and the set connect to TV, Prepare the connection as shown follow:

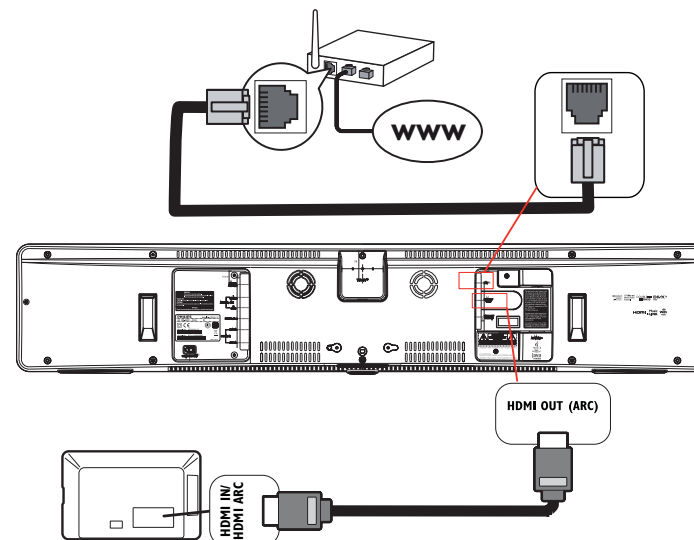

- Press “” <Home> button on R/C, and select <Setup>.
- Select <Advance Setup> <Software Update> <Network>.
- TV will show message as follow:

Now searching for upgrade software!
Please wait...!

Software updates for this player have been found. Do you want to upgrade?

Cancel

Start

- Select <Start>, press <OK> button on R/C.

Software upgrade will take 5 minutes

Do not switch off!

Package version: 000025.0

Software BE	80%
Software FE	Completed
Software MCU1:	
Software Dock:	
Software MCU3:	

Software upgrade will take 5 minutes

Do not switch off!

Package version: 000025.0

Software BE	Completed
Software FE	Completed
Software MCU1:	Not started
Software Dock:	2%
Software MCU3:	Not started

Software upgrade will take 5 minutes

Do not switch off!

Package version: 000025.0

Software BE	Completed
Software FE	Completed
Software MCU1:	1%
Software Dock:	Failed
Software MCU3:	

f) The set will shut down automatically when the software upgrade is completed.

6) How to replace the defective Blu-ray Loader

- a) Remove the defective Blu-ray Loader.
- b) Loosen 2 screws "A" on the top of BD loader jack pcb to remove the board as shown below.

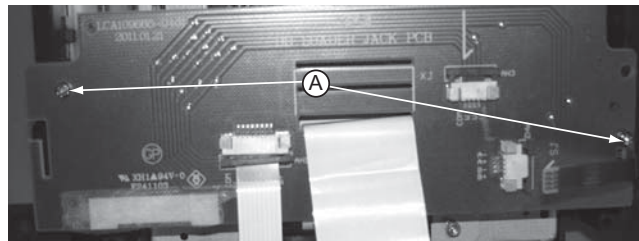

- c) Loosen 4 screws "B" to take out the "Sanyo TRV-414H05" as shown below.

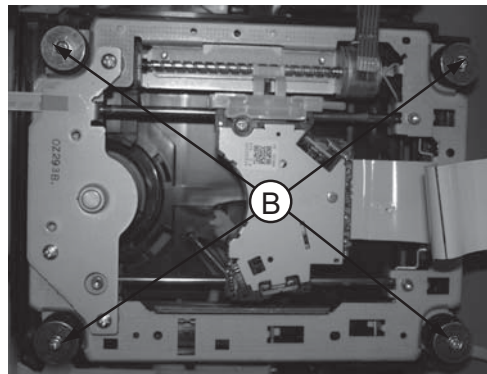

- d) Blu-ray Loader to connect "HA802" on the top of BD Board as shown below.

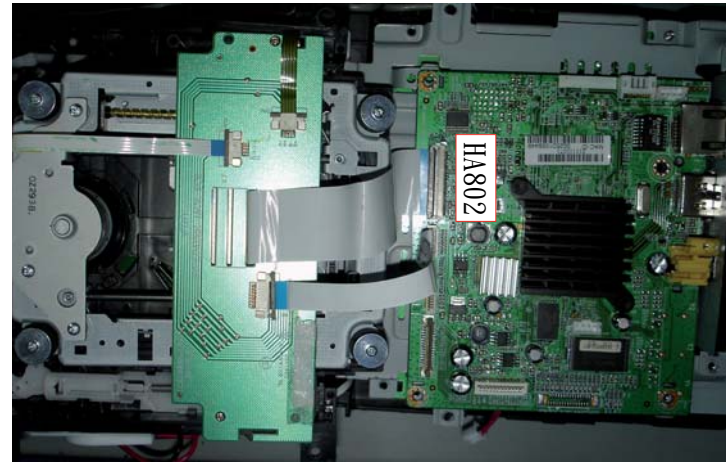

- e) Remove soldered joint on the ESD protection points.

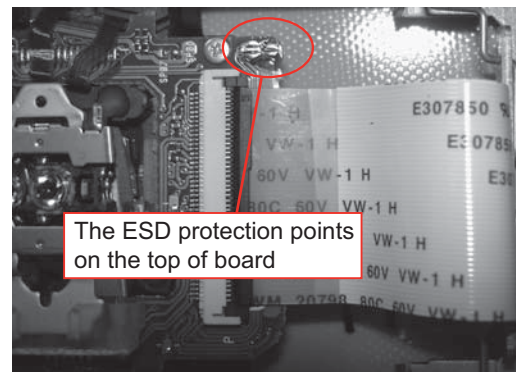

Note: The 2 ESD protection points on any one side must be soldered if

- o the Blu-ray Loader is OK and needs to be disconnected from connector HA802 of the BD Board.
- o the defective Blu-ray Loader is needed to be send back to supplier for failure analysis and to support backcharging evidence.

7) OSD Language setup (only for 51 version)

- a) Press "Home" button on R/C.
- b) Select <Setup>, then press "OK" button on R/C.
- c) Select <Preference>, then press <OK> button on R/C.
- d) Select <Menu language>, then press <OK> button on R/C.
- C) Select <English>, then press <OK> button on R/C.

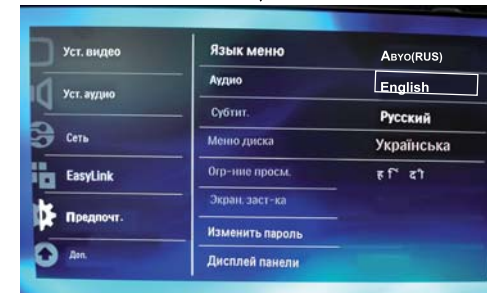
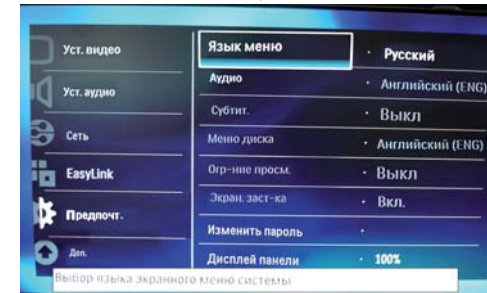
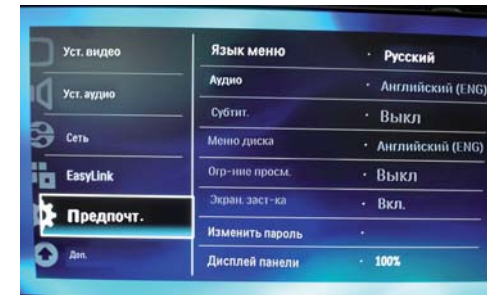

CAUTION!

This information is confidential and may not be distributed. Only a qualified service person should reprogram the Region Code.

SCH5131REPAIR CHAR T

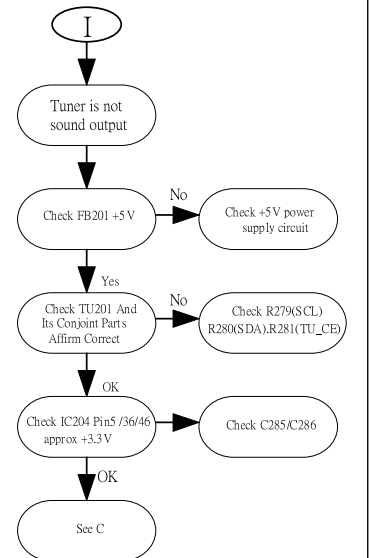
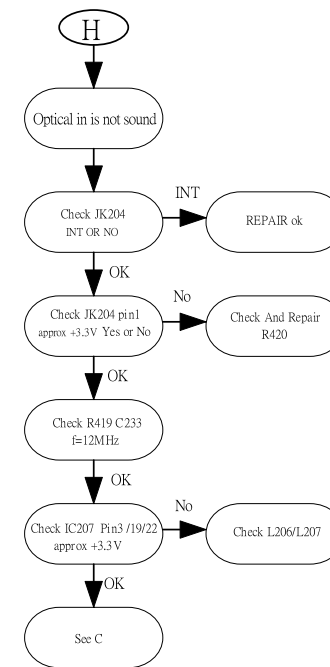
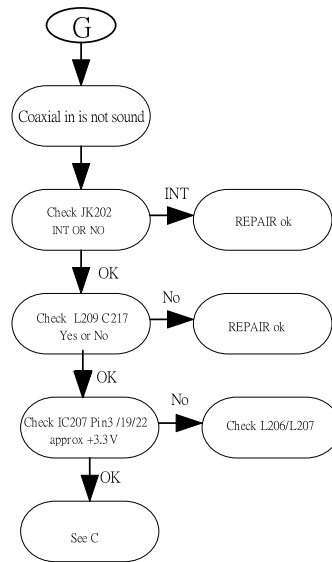
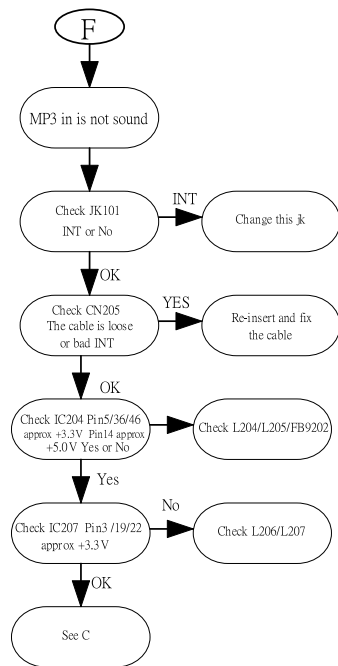
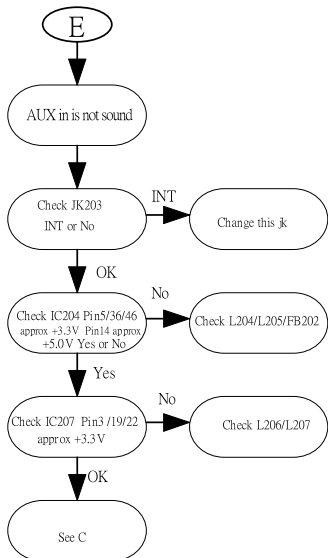
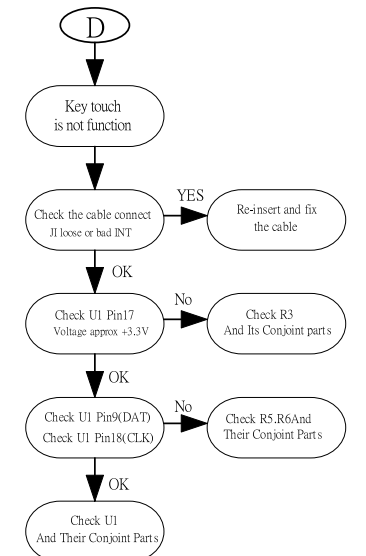
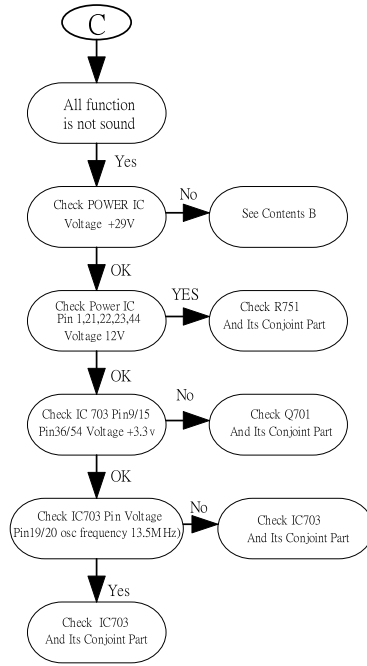
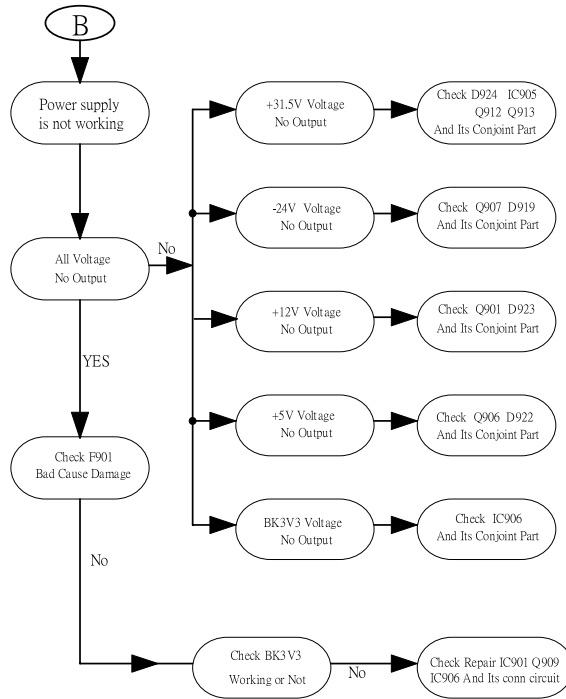
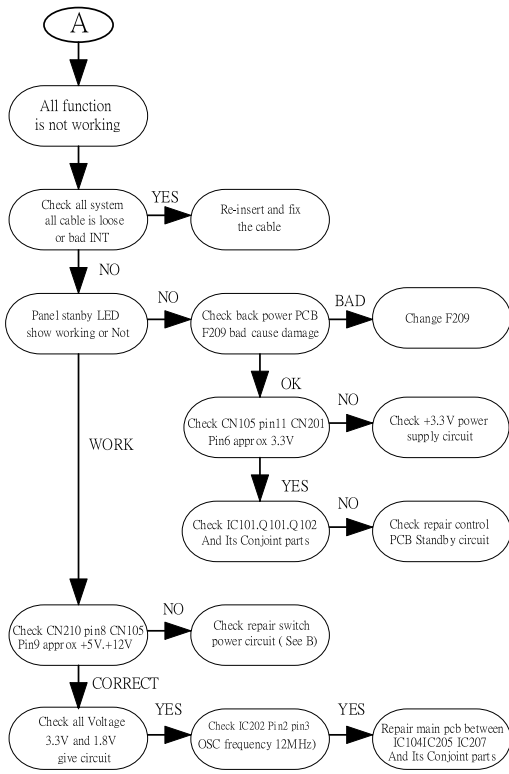
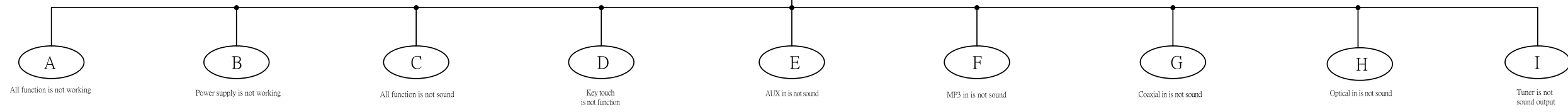

MAIN UNIT REPAIR CHART

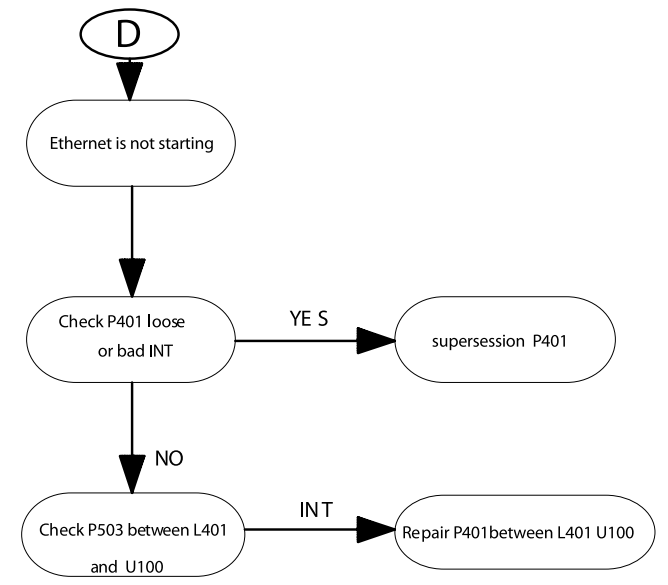
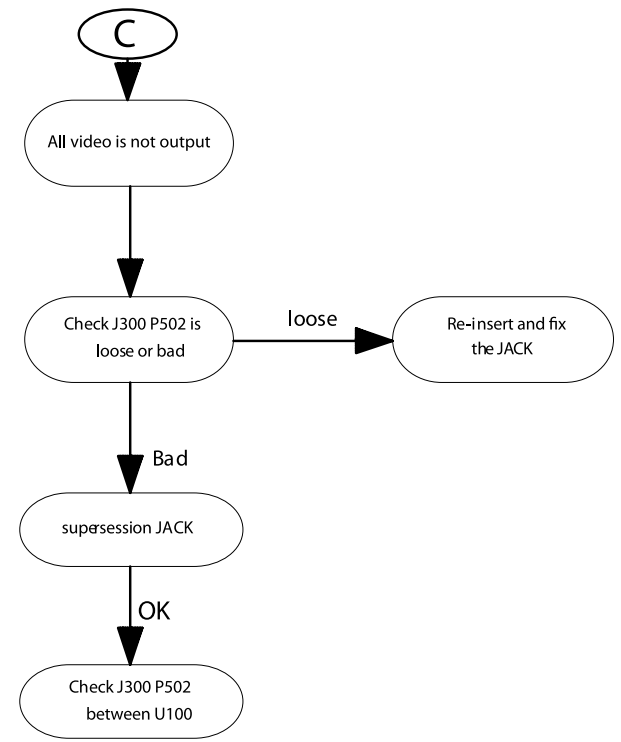
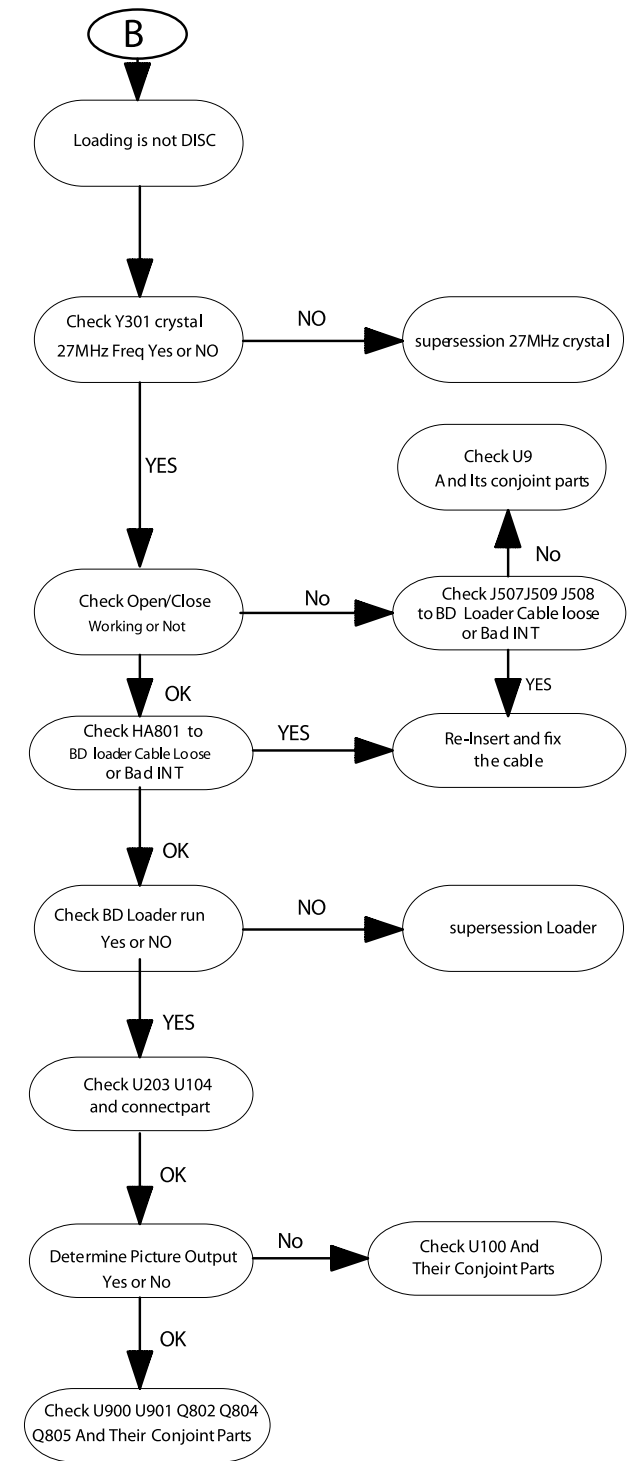
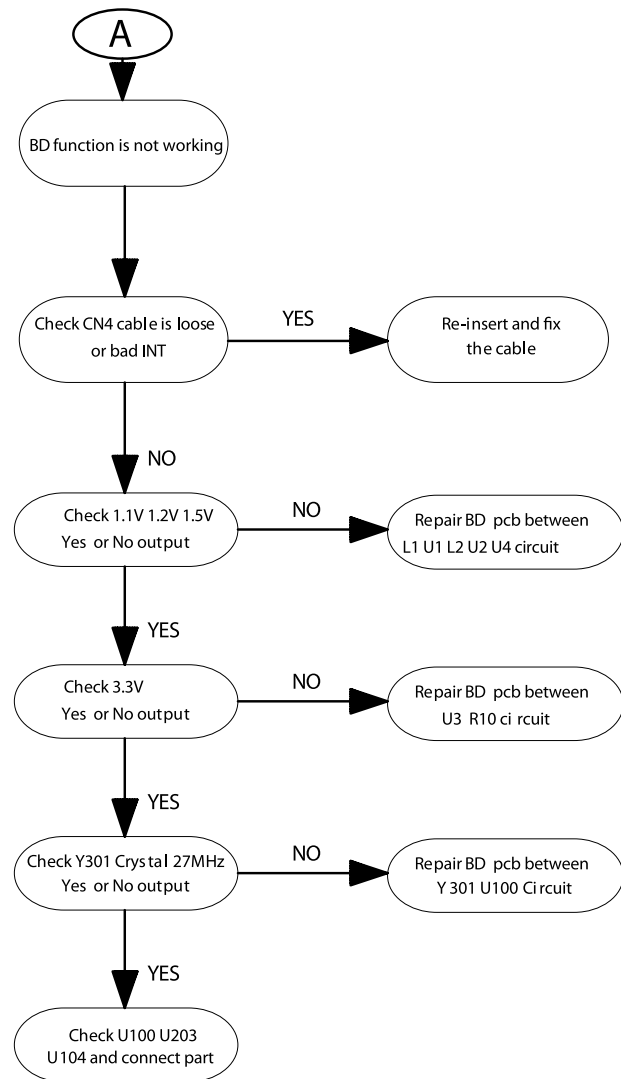

DISASSEMBLY INSTRUCTIONS

Note: In some service positions the components or copper patterns of one board may risk touching its neighbouring pc boards or metallic parts. To prevent such short-circuit use a piece of hard paper or other insulating material between them.

Dismantling of the Rear Panel Assemble

- 1) Loosen 2 screws "A" at the rear panel to remove rear stand as shown in figure 1.
- 2) Loosen 12 screws "B" at the rear panel to remove rear panel as shown in figure 2.

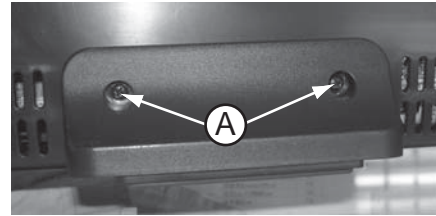

Figure 1

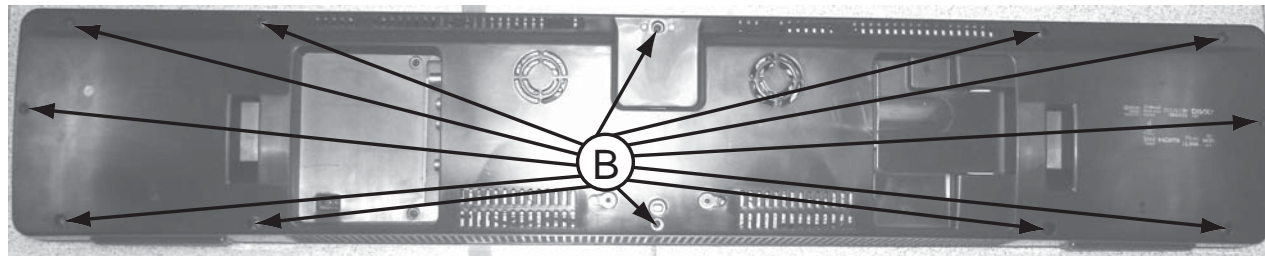

Figure 2

Dismantling of the WIFI & MP3 Board

- 1) Loosen 2 screws "C" on the top of WIFI board as shown in figure 3.
- 2) Loosen 2 screws "D" on the top of MP3 board as shown in figure 4.

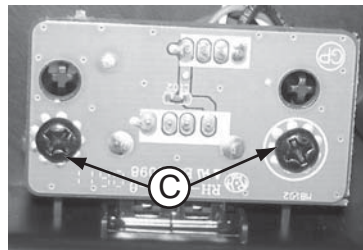

Figure 3

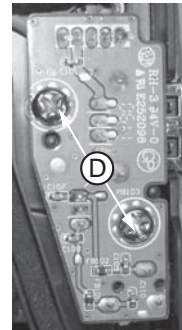

Figure 4

Dismantling of the PCB Bracket

- 1) Loosen 9 screws "E" at the PCB bracket as shown in figure 5.

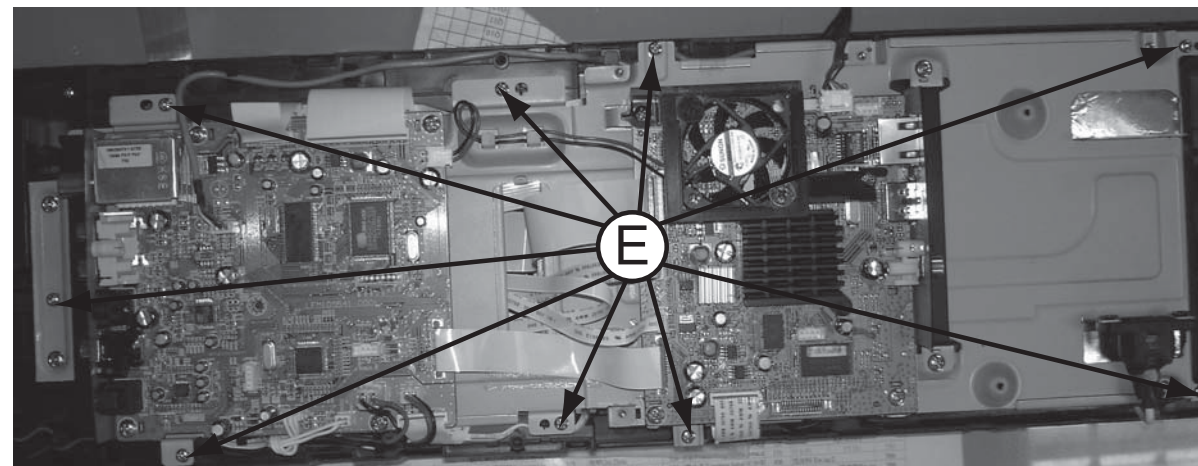

Figure 5

Dismantling of the Main Board

- 1) Loosen 6 screws "F" on the top of main board as shown in figure 6.
- 2) Loosen 5 screws "G" at the main board jack bracket to remove the main board as shown in figure 7.

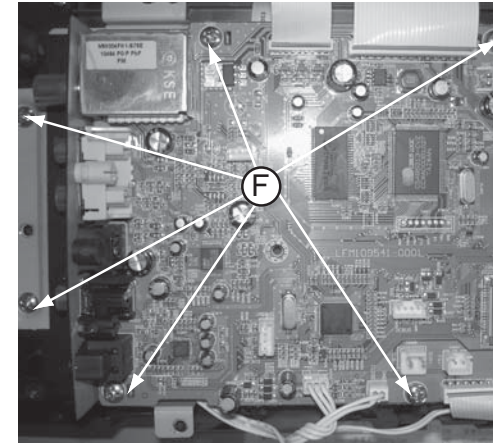

Figure 6

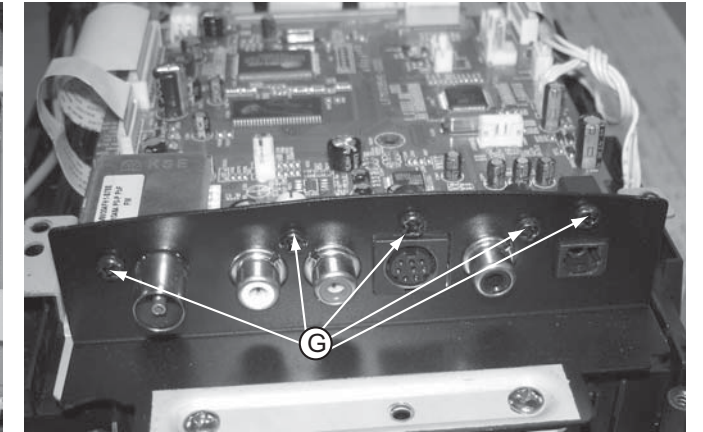

Figure 7

Dismantling of the BD Board

- 1) Loosen 2 screws "H" at the BD board jack bracket as shown in figure 8.
- 2) Loosen 6 screws "I" to remove BD board as shown in figure 9.

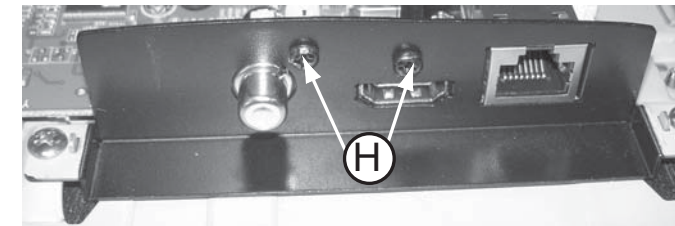

Figure 8

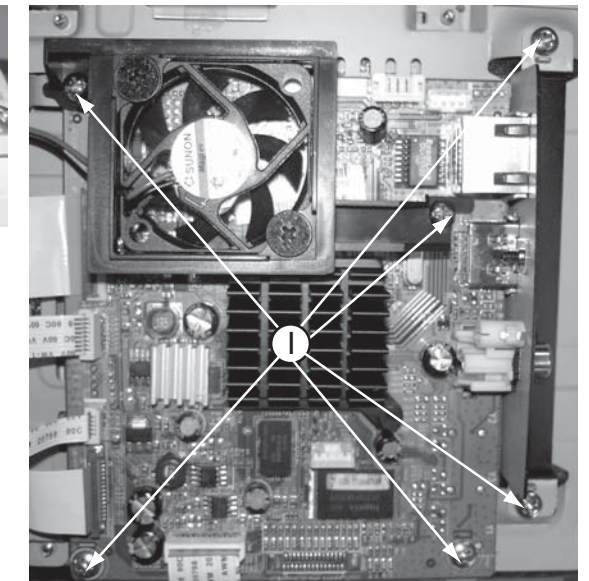

Figure 9

Dismantling of the Power Board

- 1) Loosen 6 screws "J" to remove the power board as shown in figure 10.
- 2) Loosen 2 screws "K" to remove the AC socket as shown in figure 11.

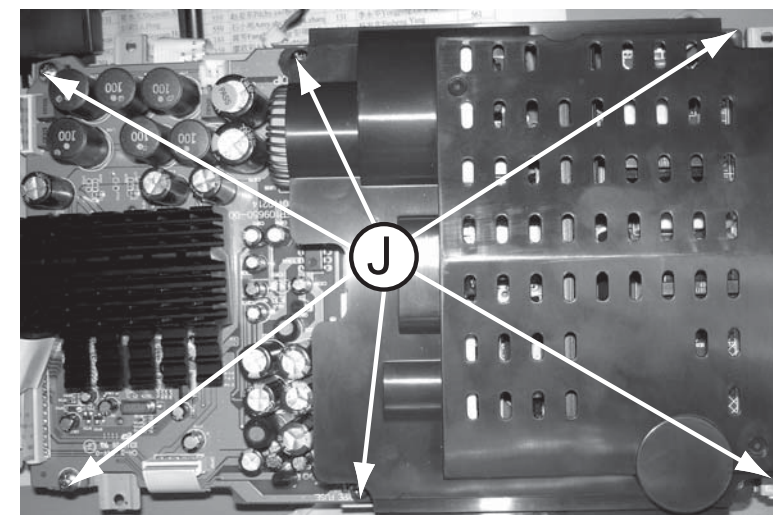

Figure 10

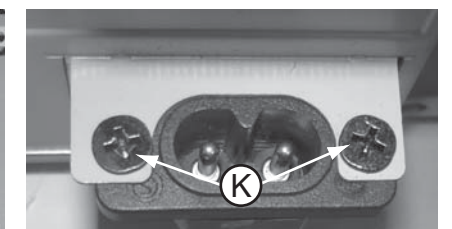

Figure 11

Dismantling of the BD Module

- 1) Loosen 6 screws "L" as shown in figure 12.
 - 2) Loosen 2 screws "M" to remove the BD module as shown in figure 13.
- Note: When install the BD module, please note the part of as shown in figure 14.

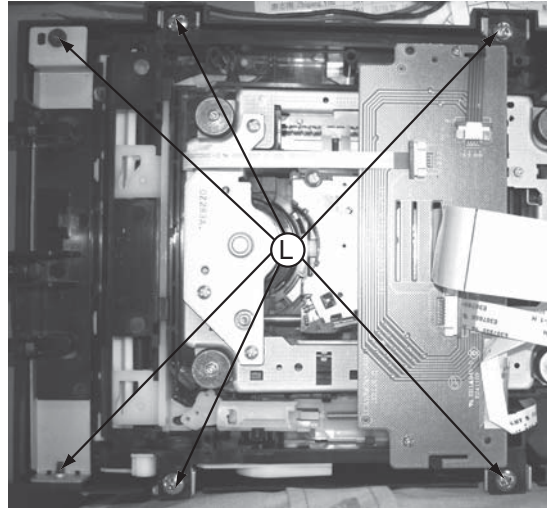

Figure 12

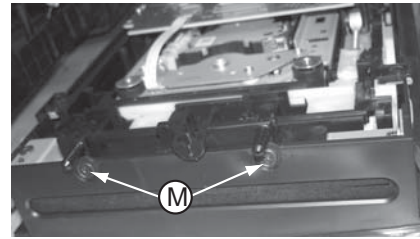

Figure 13

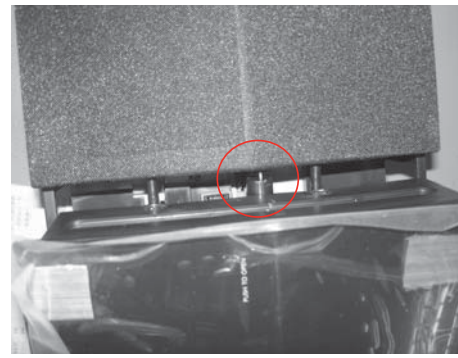

Figure 14

Dismantling of the VFD Board

- 1) Loosen 1 screw "N" on the top of VFD board to remove the VFD board as shown in figure 15.

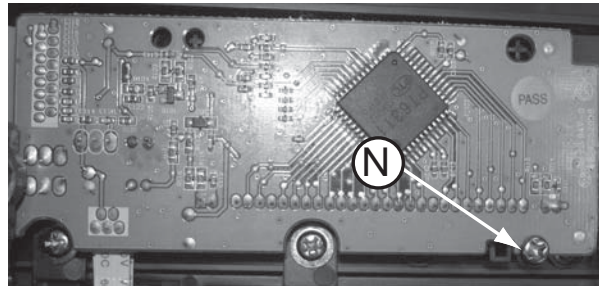

Figure 15

Dismantling of the Touch Board

- 1) Loosen 6 screws "O" to remove the Touch board as shown in figure 16.

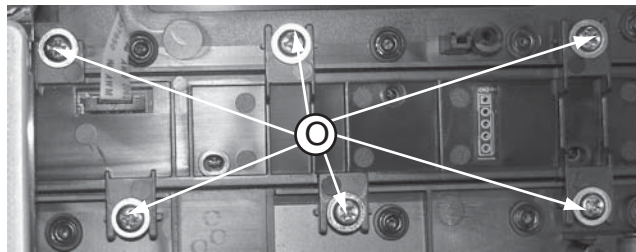

Figure 16

Dismantling of the Stop SW+Open SW+Close SW Board & Damper

- 1) Loosen 2 screws "P" to remove stop sw+open sw board as shown in figure 17.
- 2) Loosen 1 screws "Q" to remove close sw board as shown in figure 18.

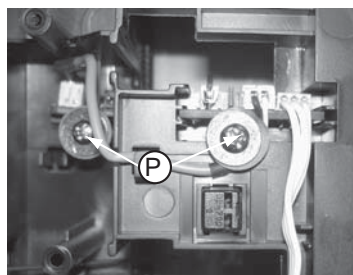

Figure 17

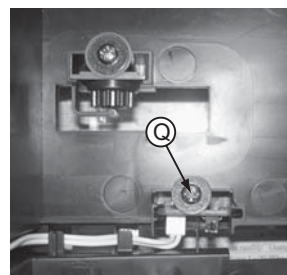
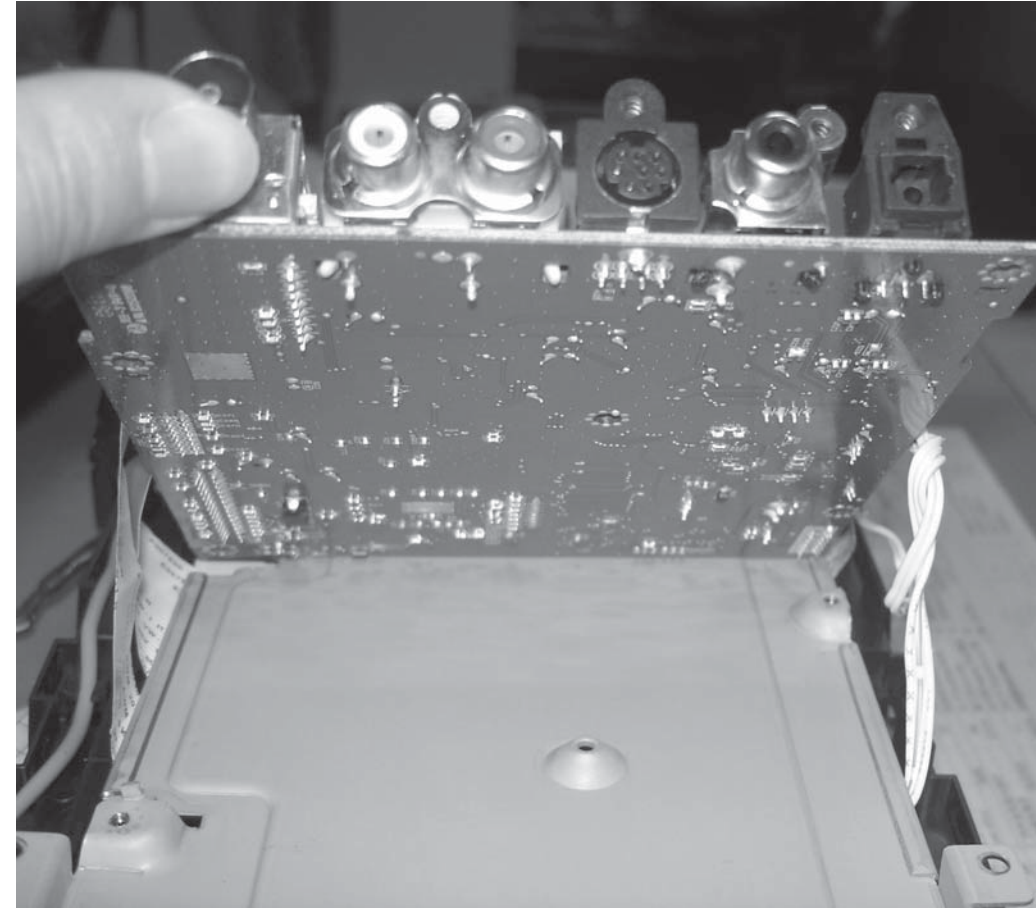

Figure 18

SERVICE POSITIONS

Service Position A - Main Board



Service Position B - BD Board

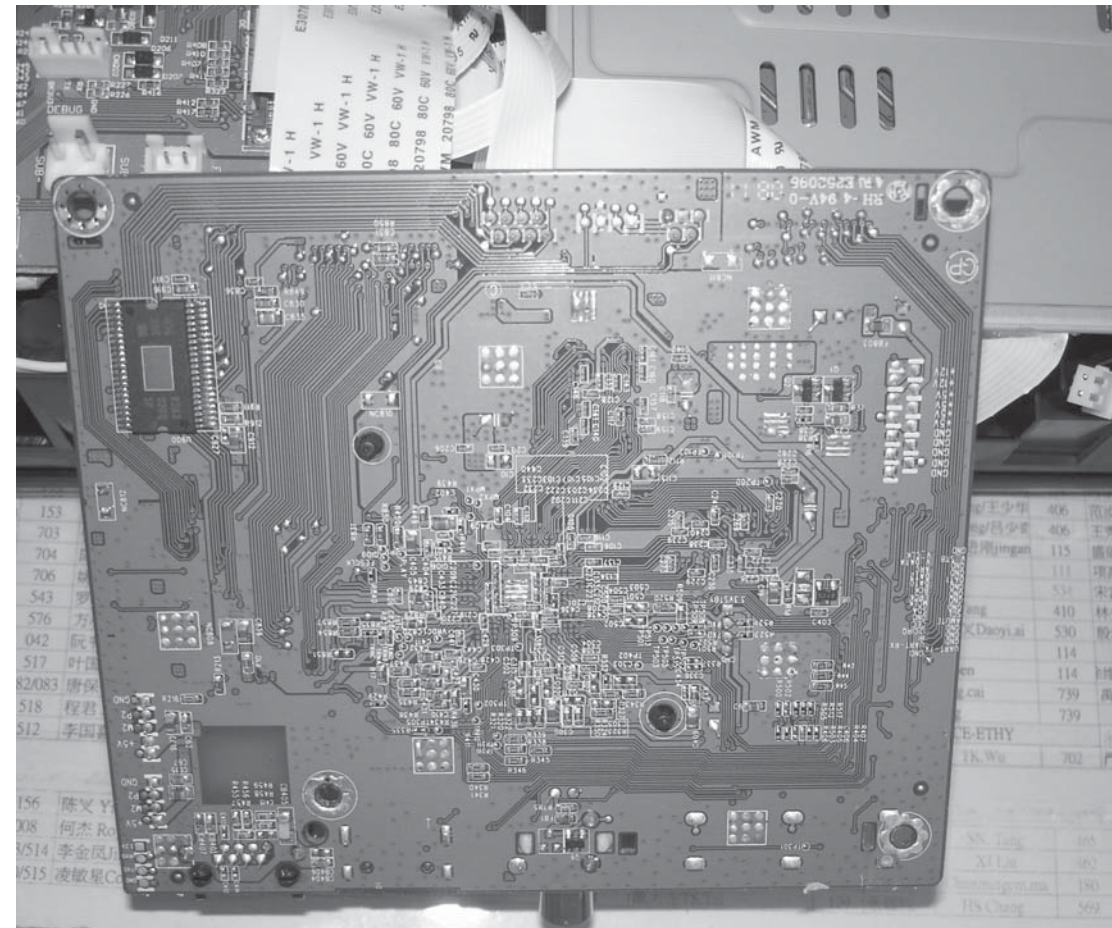

Service Position C - VFD Board

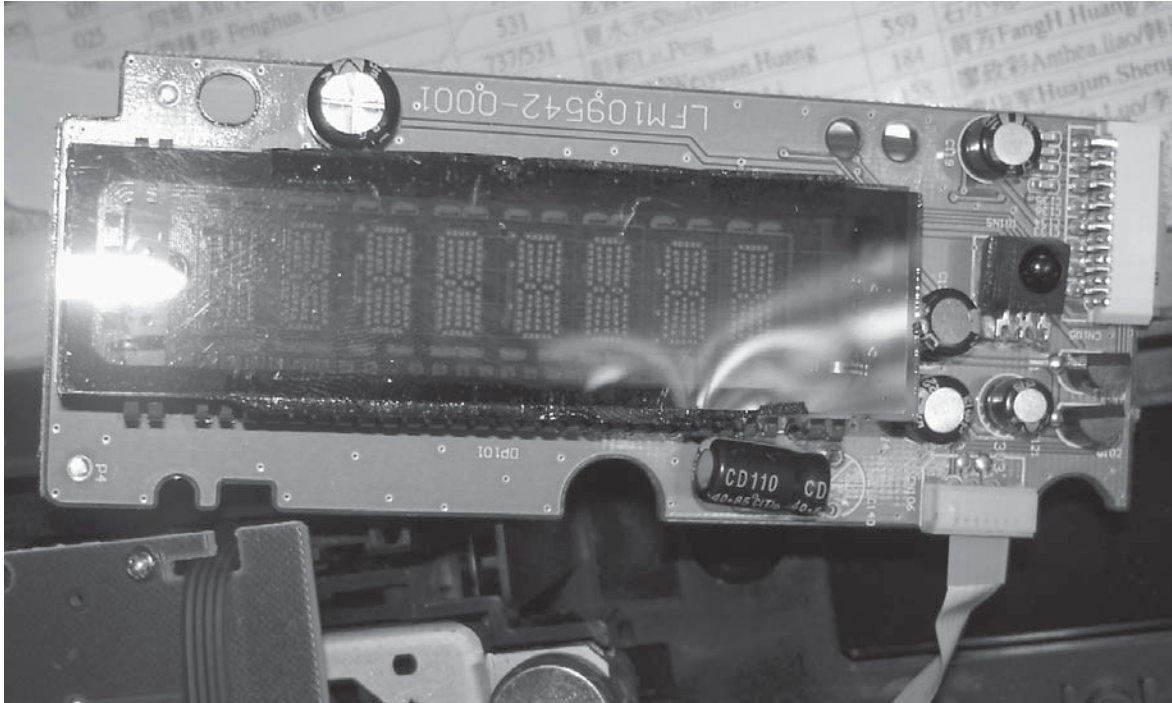

Service Position D - ALL Board

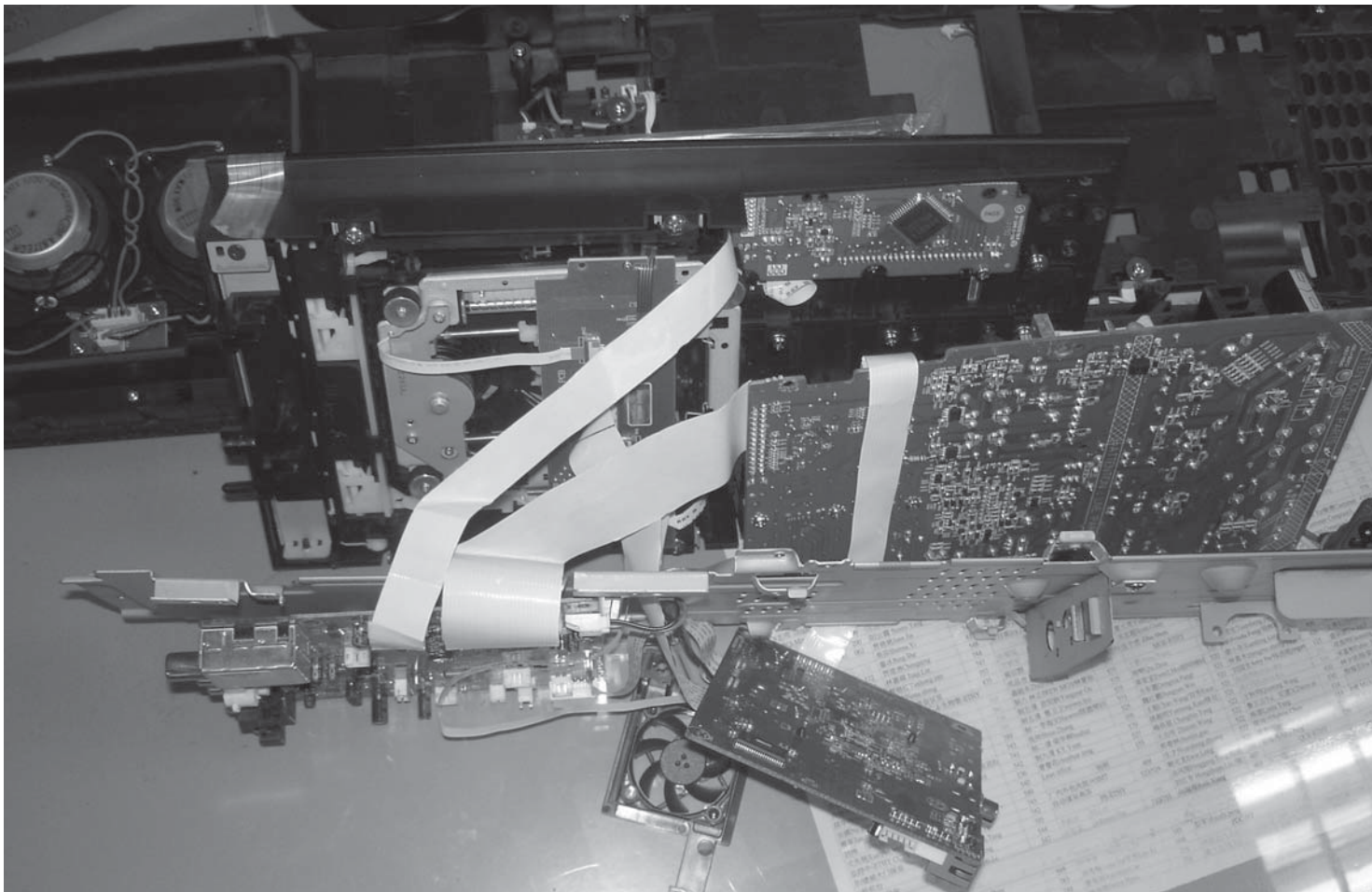

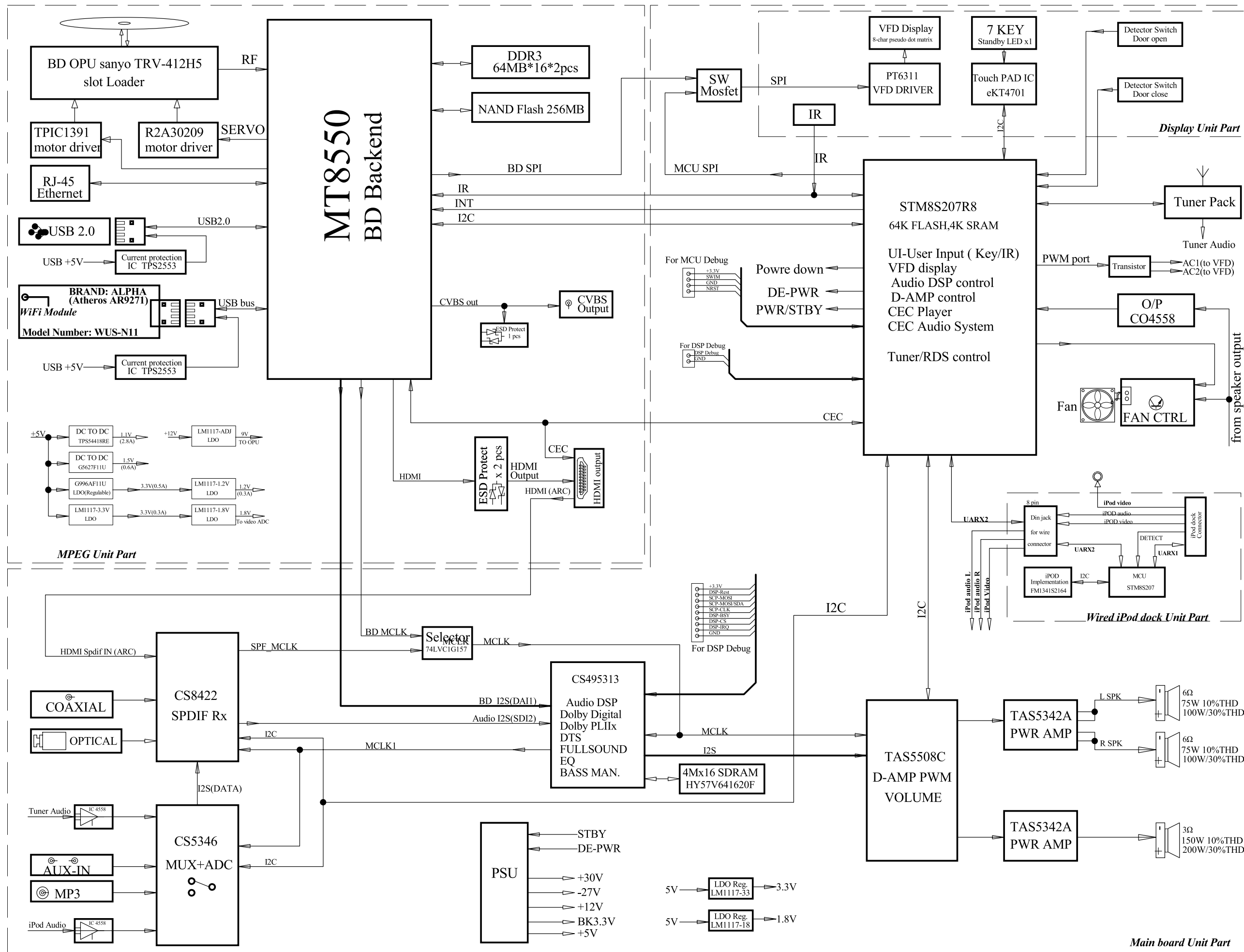

WIRING DIAGRAM

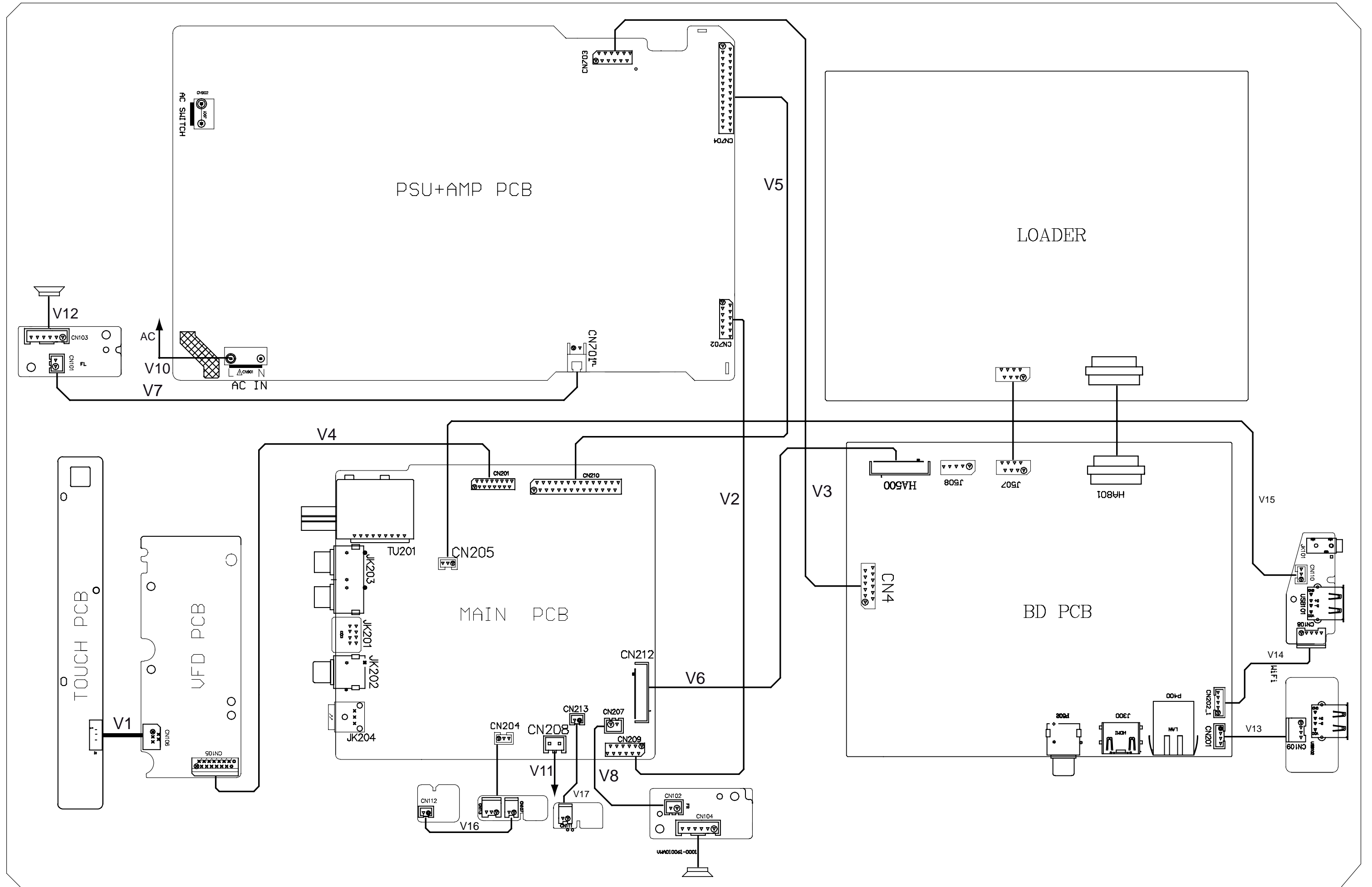

QUICK START GUIDE

The following excerpt of the QSG/DFU serves as an introduction to the set.

The complete Direction for Use can be download in the different languages from the internet site of Philips Consumer Care Center: www.support.philips.com.

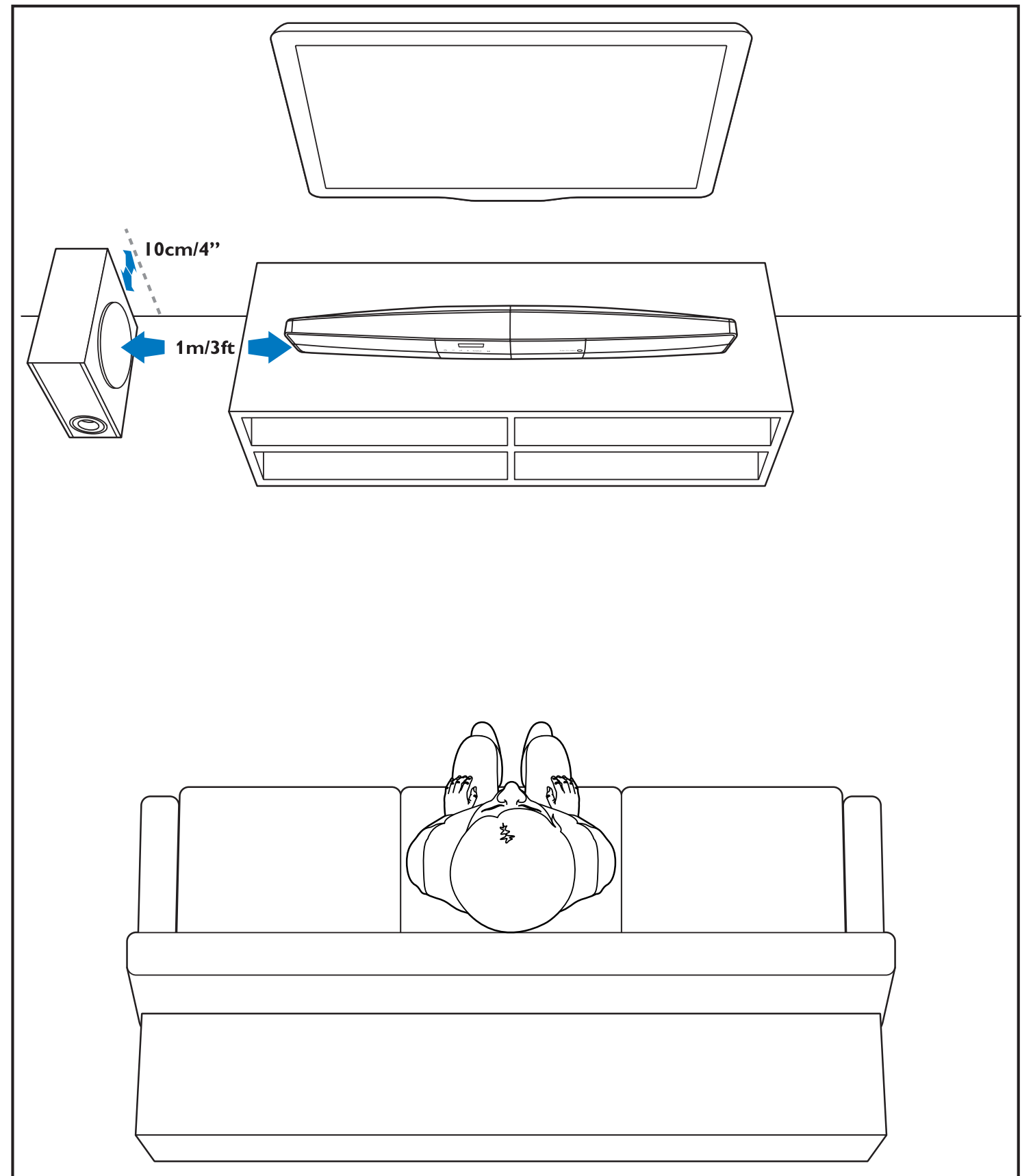
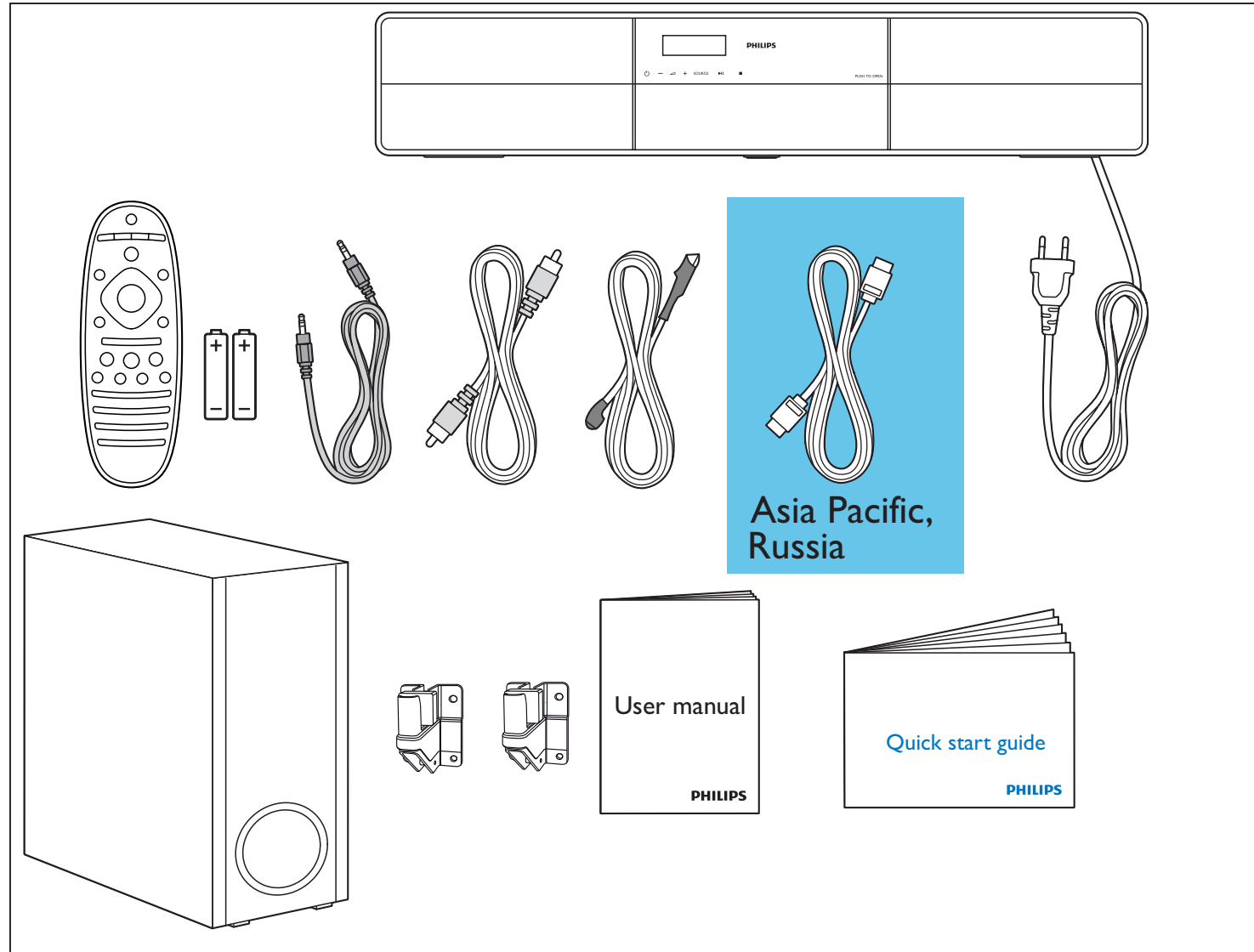

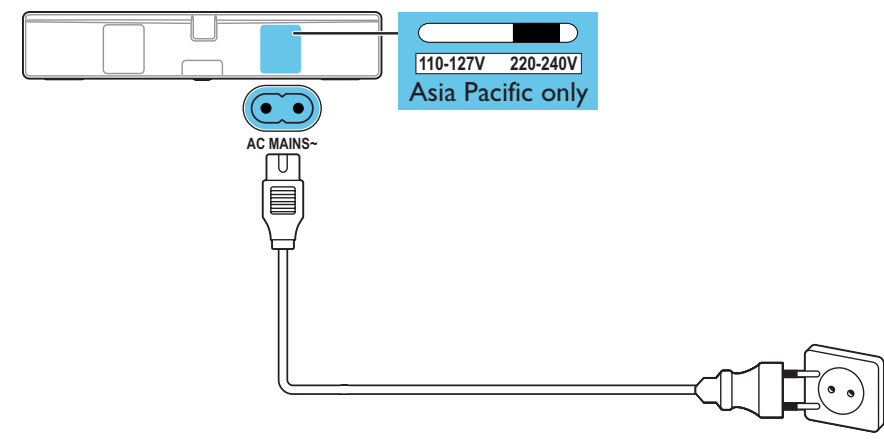
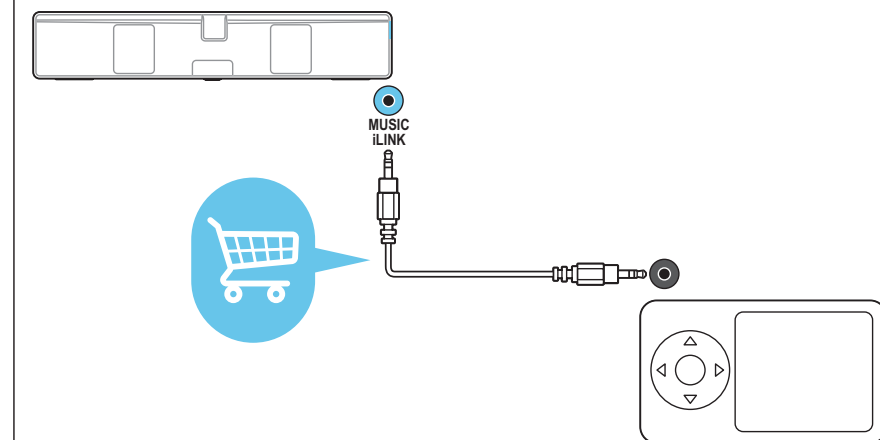
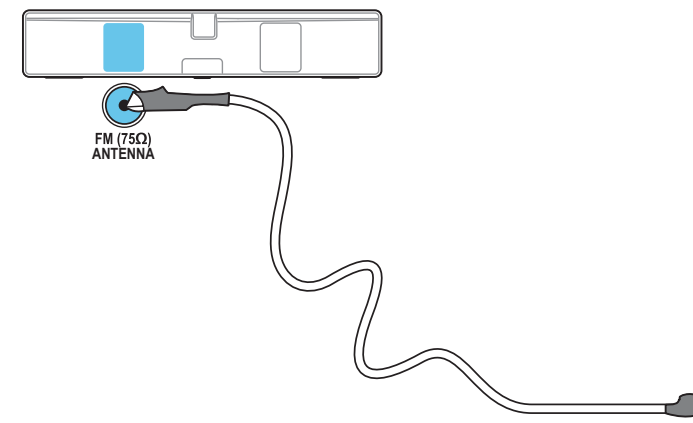
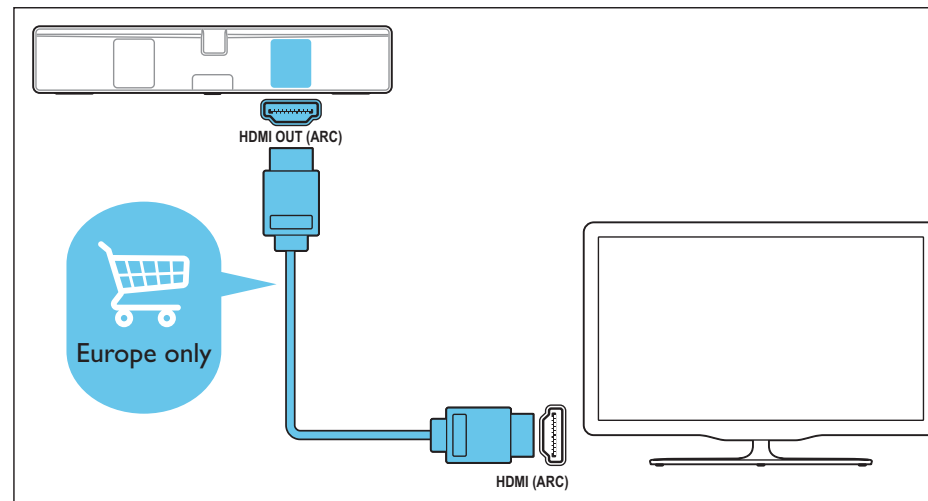
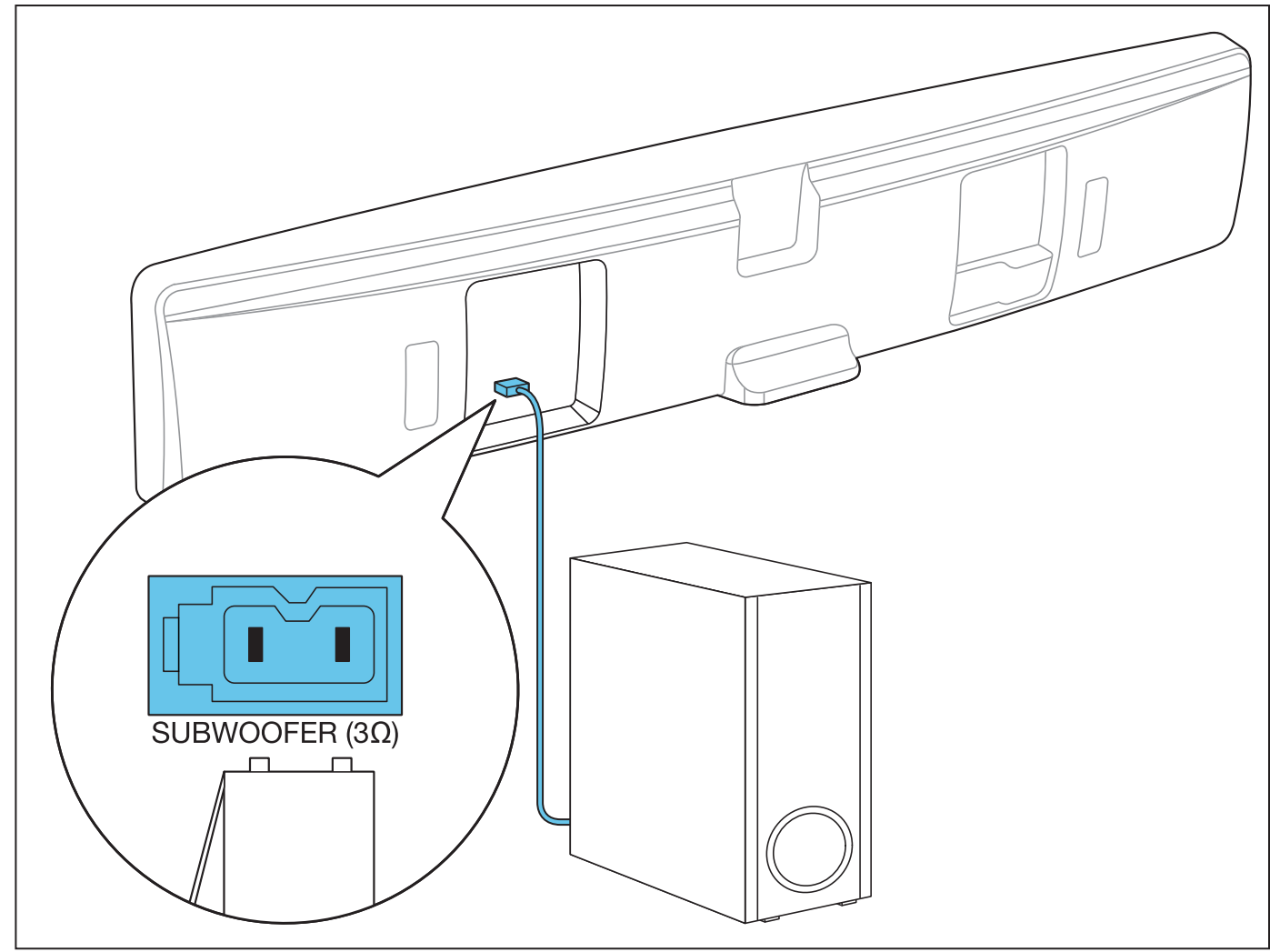
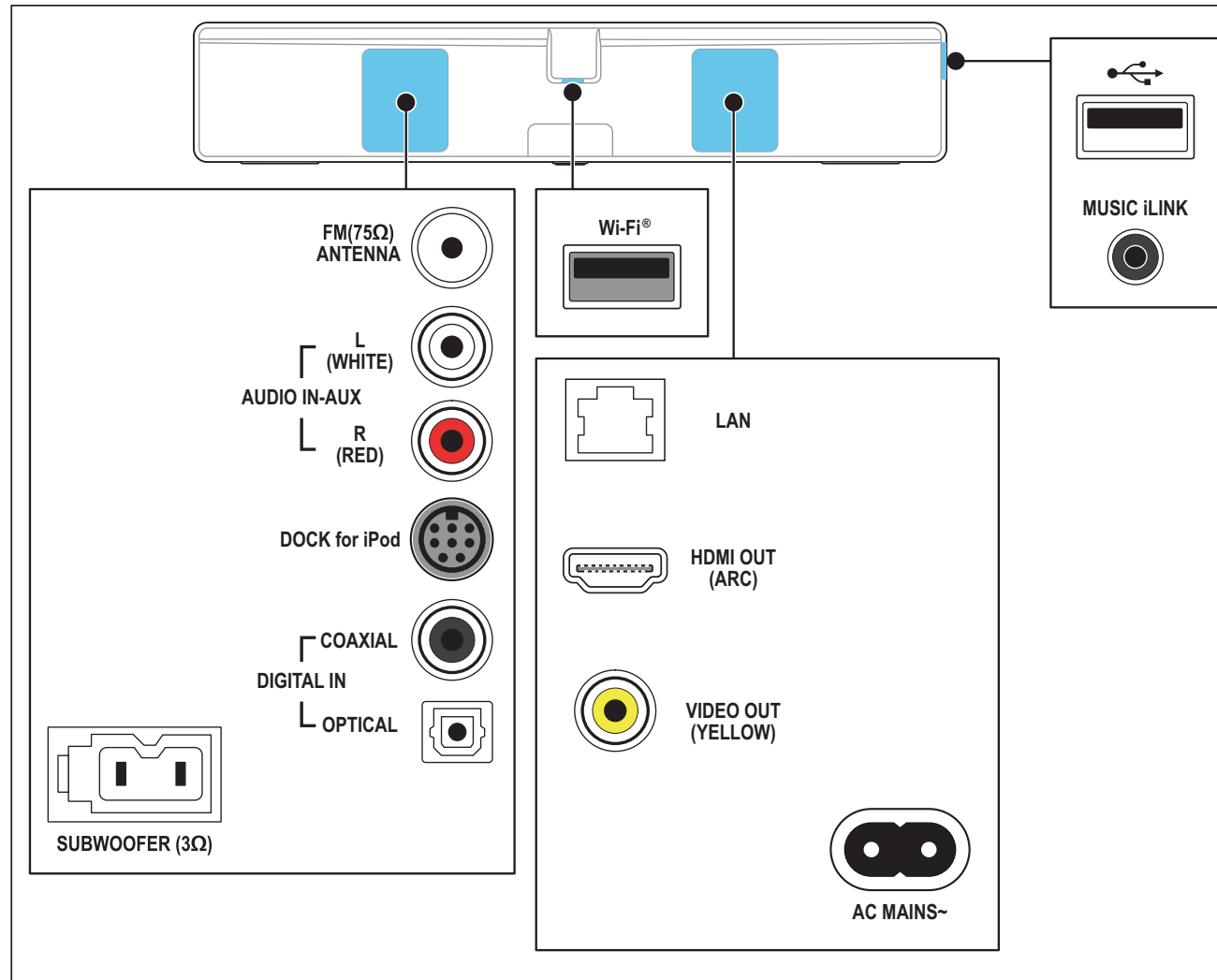

1

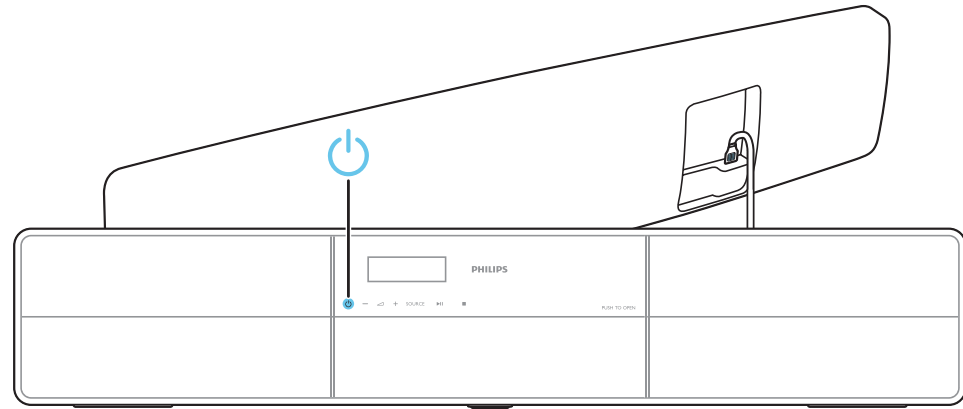

2

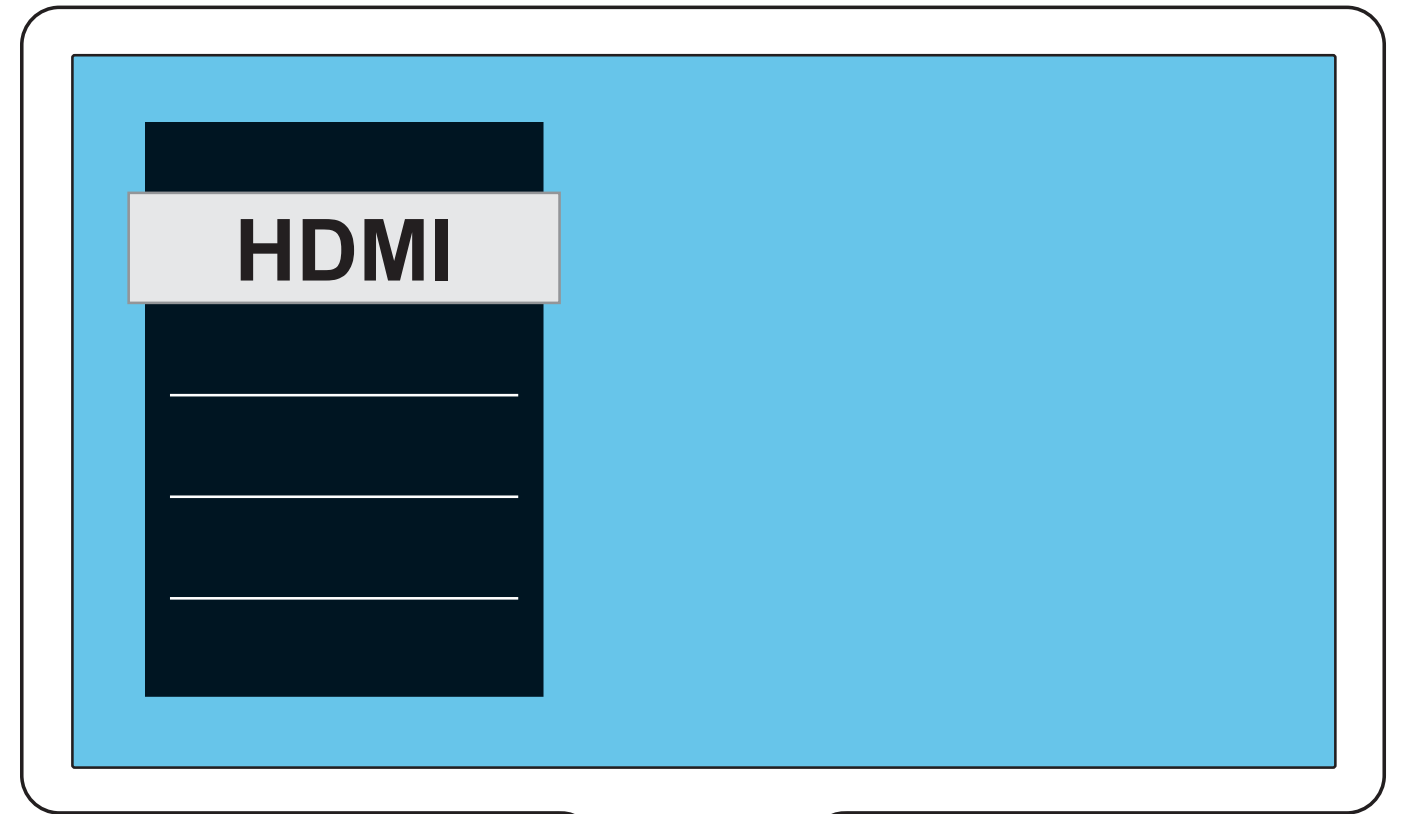
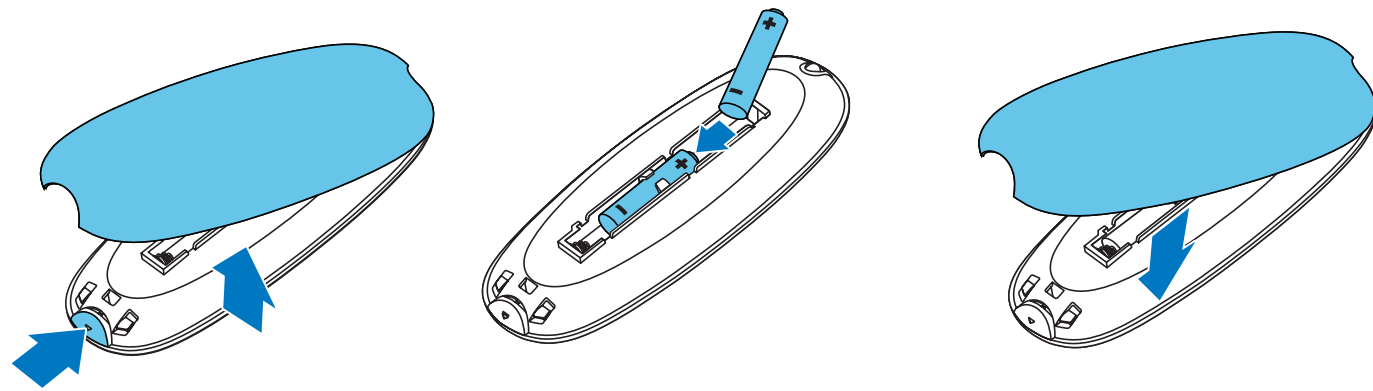

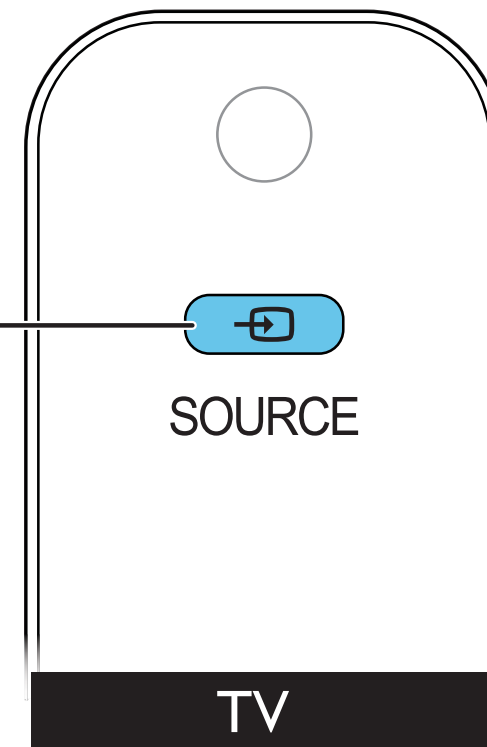

1

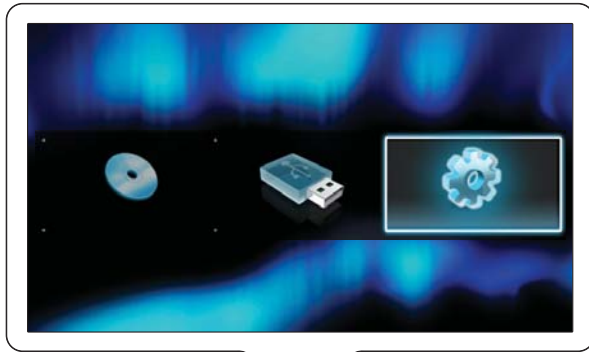
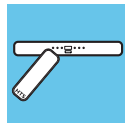

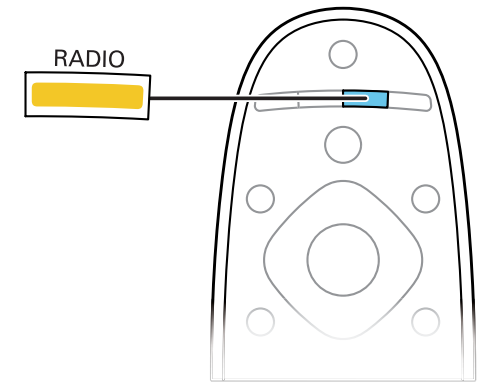
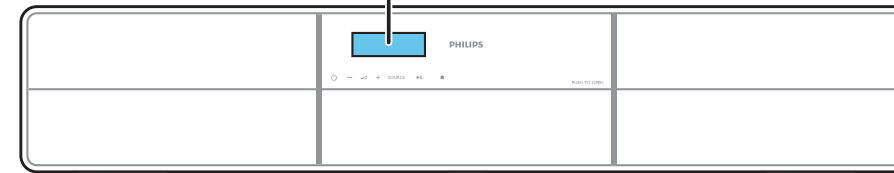
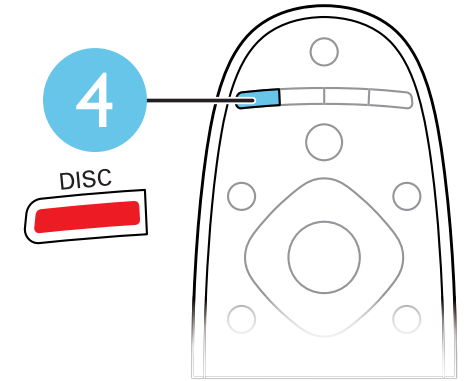
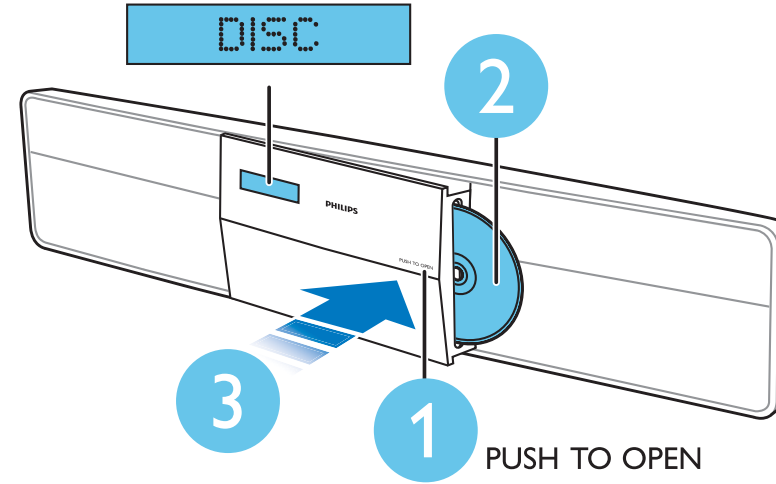
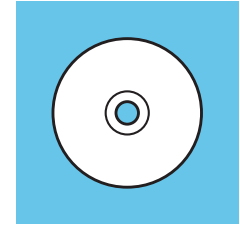
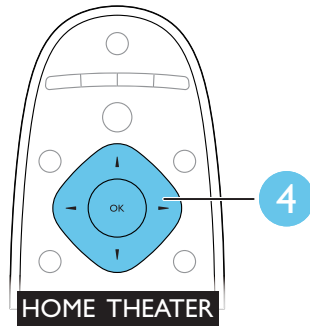
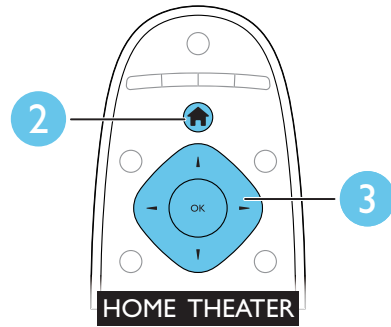

Video	Menu language	Auto (ENG)
Audio	Audio	English
Network	Subtitle	Français
EasyLink	Disc Menu	Deutsch
Preference	Parental Control	Italiano
Advanced	Screen Saver	Español
	Change Password	Português
	Display Panel	Nederlands
	Auto Standby	Dansk
		Norsk
		Svenska





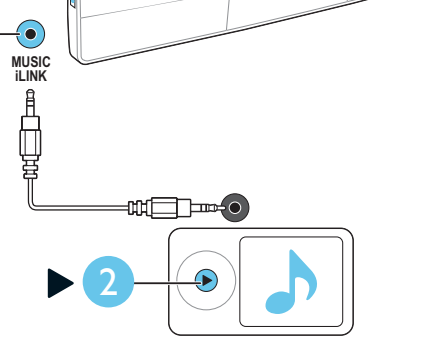

1. Connect I-LINK cable to the remote.



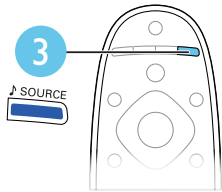

2. Press the I-LINK button on the remote.



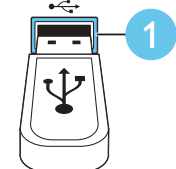

1. Insert MP3 player into the remote.





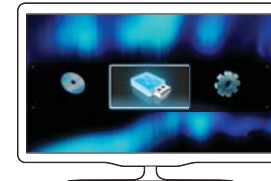

1. Insert USB drive into the remote.

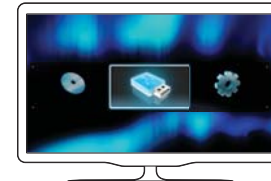

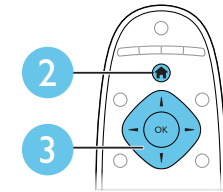

2. Press the OK button on the remote.





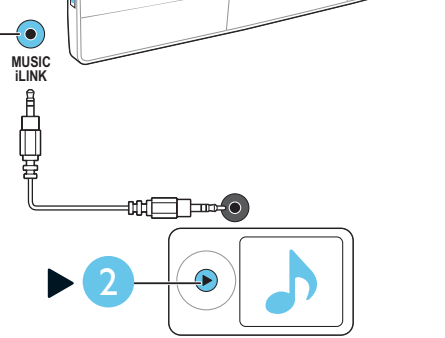

1. Connect I-LINK cable to the remote.



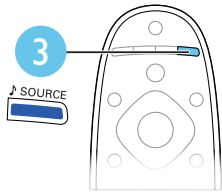

2. Press the I-LINK button on the remote.



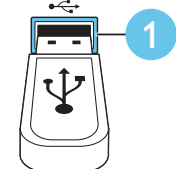

1. Insert MP3 player into the remote.





1. Insert USB drive into the remote.

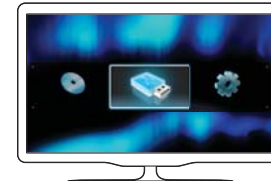

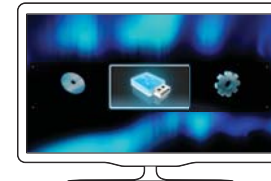

2. Press the OK button on the remote.

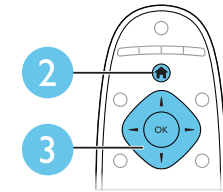

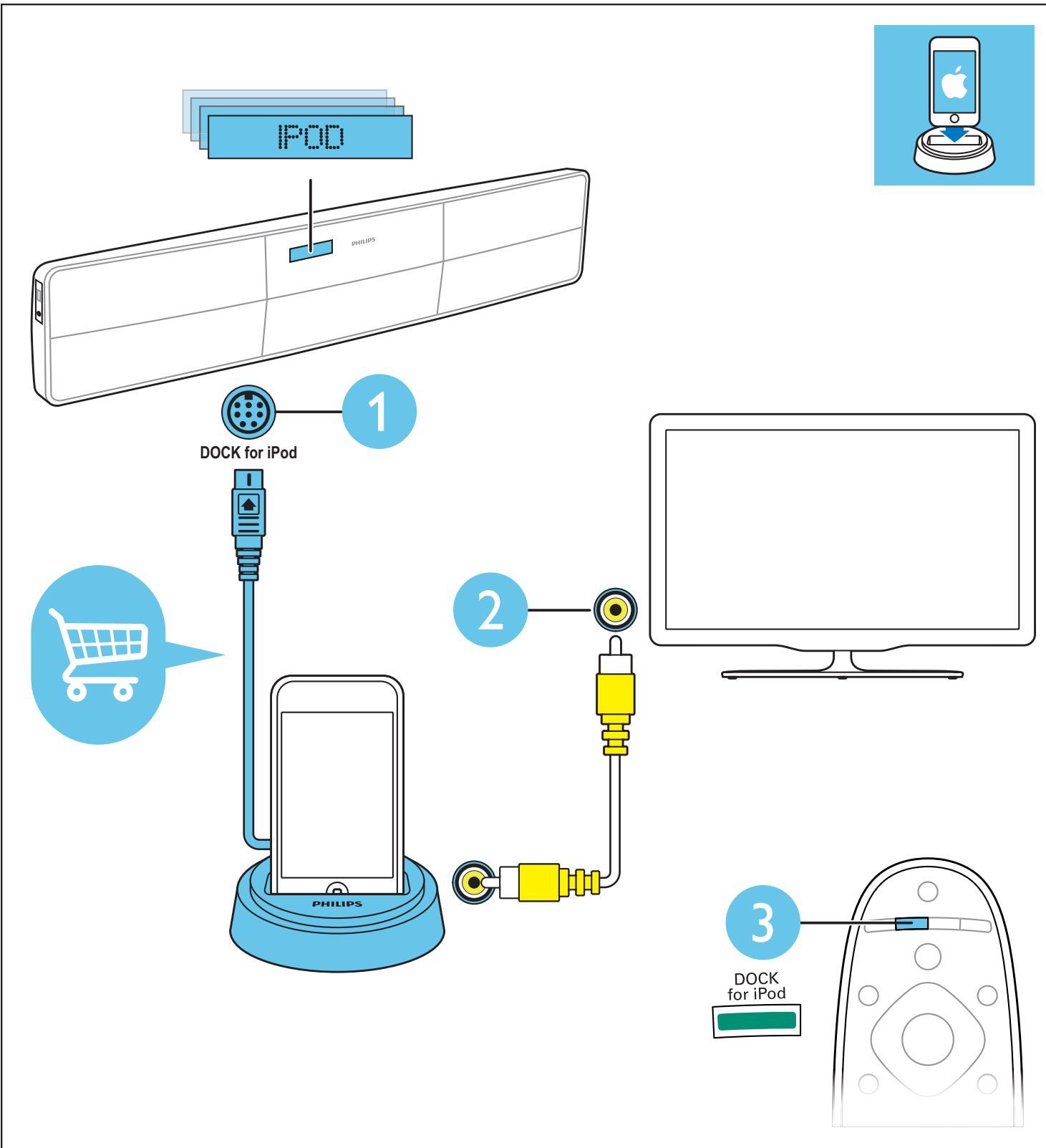

MAIN+VFD+FR+FL+MP3+WIFI+OPEN+CLOS+RFS BOARD

TABLE OF CONTENTS

Internal IC Diagram 6-1
 Circuit Diagram (part one) 6-2
 Circuit Diagram (part two)..... 6-3
 PCB Layout Top View 6-4
 PCB Layout Bottom View 6-5

6 - 1
INTERNAL IC DIAGRAM - CS495313-CVZ

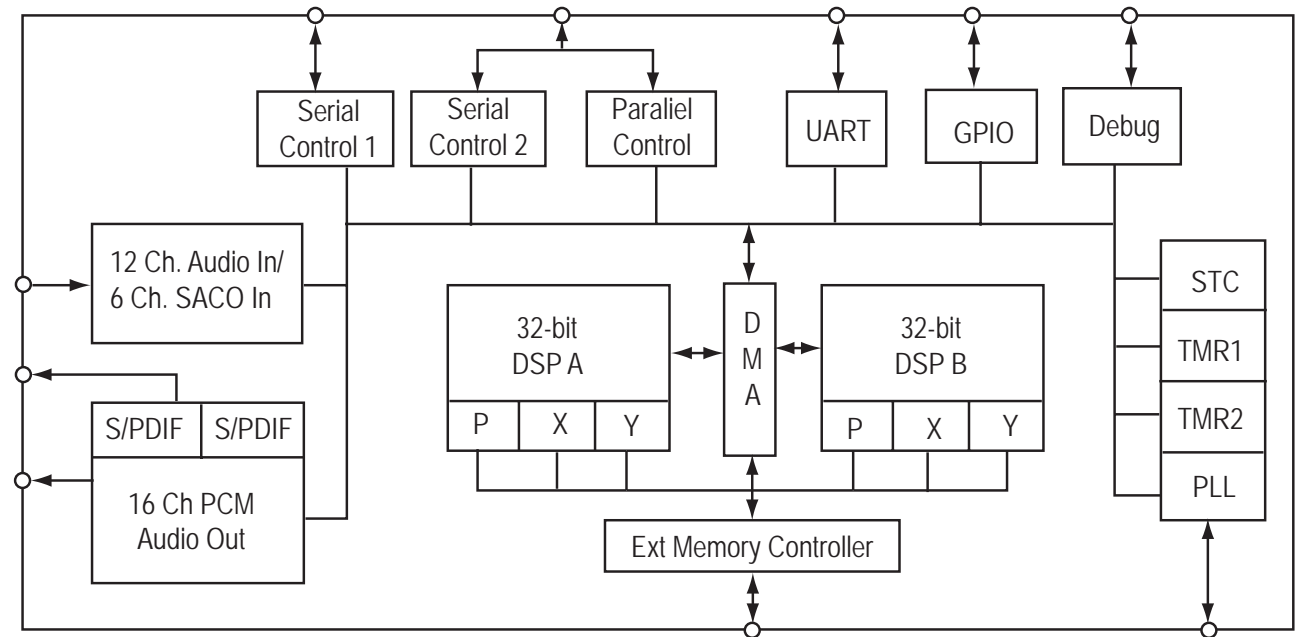

INTERNAL IC DIAGRAM - EM638165TS-6G

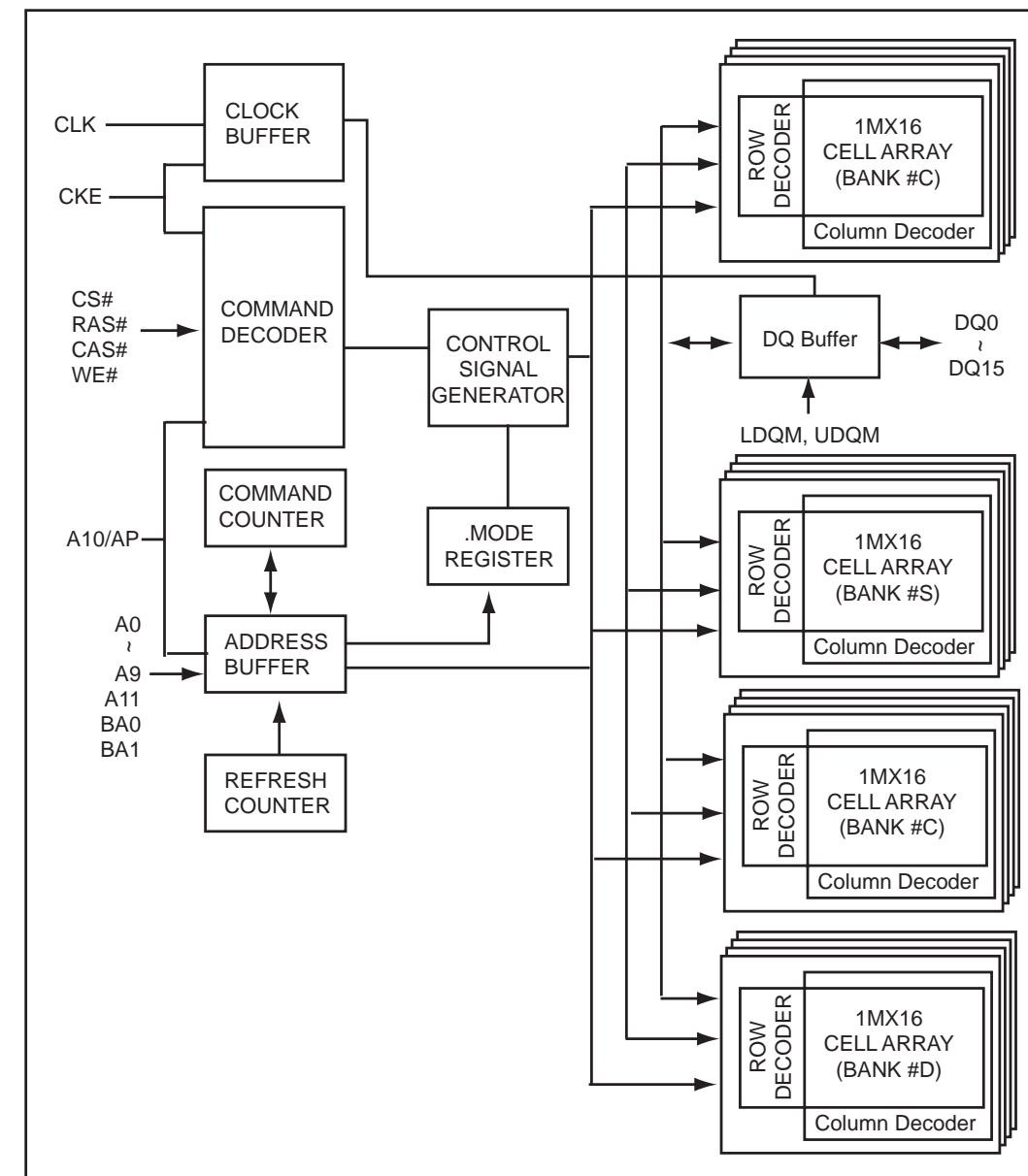

CIRCUIT DIAGRAM-(part one)

C201	A1	C220	C2	C237	D1	C254	D3	C271	A1	C290	A2	C308	B3	C328	B4	C347	C2	C364	C4	C381	D2	CN213	A1	FB208	B4	L201	B2	Q204	A3	R229	A2	R246	A2	R263	B2	R279	B1	R296	C3	R315	C2	R334	D1	R355	B3	R372	B3	R390	C1	R407	C4	R426	B2
C202	A1	C221	B4	C238	D1	C255	D3	C272	A1	C291	A2	C309	B3	C329	D4	C348	C2	C365	C4	C382	D3	D201	A3	FB209	A4	L202	B2	Q205	A4	R230	A2	R247	A2	R264	A3	R280	A1	R297	C3	R316	D1	R335	C1	R356	D2	R373	A3	R391	C1	R408	C4	R427	B4
C203	A1	C222	B4	C239	C1	C256	D3	C273	C4	C292	A2	C310	B1	C330	D4	C349	C2	C366	C4	C383	C3	D203	A4	IC202	A2	L203	B2	R201	A1	R231	A2	R248	A2	R265	B3	R281	B1	R298	B3	R317	D2	R336	D1	R357	D4	R374	B4	R392	C1	R409	C4	RA201	C3
C204	A1	C223	B4	C240	C2	C257	D3	C274	C4	C293	A3	C311	B1	C333	B4	C350	C3	C367	D1	C384	D3	D204	A4	IC203	B2	L204	C2	R203	A3	R232	A2	R249	B2	R266	B3	R282	B3	R299	C3	R318	C3	R337	B1	R358	D4	R375	B4	R393	C2	R410	C4	RA202	C3
C205	A1	C224	B4	C241	C2	C258	D3	C275	C4	C294	A3	C312	B1	C334	C1	C351	B3	C368	D1	C387	A2	D205	A4	IC204	C2	L205	C2	R205	A1	R233	A2	R250	B2	R267	B3	R283	C2	R300	C3	R319	C3	R338	B1	R359	D4	R376	B4	R394	D1	R411	D4	RA203	C3
C206	A2	C225	B4	C242	C2	C259	D3	C276	C4	C295	A3	C313	B1	C335	C1	C352	C3	C369	D1	C388	A4	D206	B4	IC205	C3	L206	D1	R206	A1	R234	A2	R251	B2	R268	A2	R284	C2	R301	C3	R320	C3	R339	B1	R360	B3	R377	B4	R395	C3	R412	D4	RA204	B3
C207	A4	C226	B4	C243	D2	C260	D3	C277	C4	C297	A4	C314	B1	C336	C1	C353	C4	C370	D2	CN201	A1	D208	D4	IC206	C4	L207	C2	R207	A1	R235	A2	R252	B2	R269	A3	R285	C2	R302	C3	R321	C3	R340	A1	R361	B3	R378	B4	R396	C2	R413	C2	RA205	C3
C208	A4	C227	B4	C244	D3	C261	D3	C278	C4	C298	A4	C315	C1	C337	C1	C354	B4	C371	D1	CN202	A1	D209	B2	IC206	C4	L208	D2	R218	A2	R236	A2	R253	B2	R270	A3	R286	C2	R303	C3	R322	C4	R341	B1	R362	C3	R379	B4	R397	C2	R414	C2	RA206	C3
C209	A4	C228	C4	C245	D3	C262	D3	C279	A1	C299	B1	C316	C1	C338	C1	C355	C4	C372	D1	CN203	A1	D210	B4	IC207	C1	L209	C1	R219	A3	R237	A3	R254	B2	R271	A3	R287	C2	R304	C4	R323	D4	R346	B2	R363	C3	R380	B4	R398	C2	R415	C3	RA207	C3
C210	A4	C229	C4	C246	D3	C263	D4	C280	A1	C300	B1	C317	C1	C339	C1	C356	C4	C373	D1	CN204	A1	D211	B4	IC208	D2	L210	D3	R220	A2	R238	D1	R255	B2	R271	A3	R288	C2	R305	C4	R326	B1	R347	B2	R364	B3	R382	C1	R399	C2	R417	D4	TU201	A1
C211	B1	C230	C4	C247	D3	C264	D4	C281	A1	C301	B1	C318	C1	C340	C1	C357	C4	C374	C1	CN205	C1	D212	A2	IC209	D4	MS201	A1	R221	A2	R239	A3	R256	B2	R272	A3	R289	C2	R306	D1	R327	B1	R348	B2	R365	B3	R383	D1	R400	C2	R418	C3	XL201	A2
C214	A3	C231	C4	C248	D3	C265	A1	C284	A1	C302	B1	C322	B2	C341	B1	C358	D4	C375	D2	CN206	A3	FB201	A1	IC209	D4	MS202	A1	R222	A2	R240	A3	R257	B2	R273	A4	R290	C2	R307	C1	R328	B1	R349	B2	R366	A3	R384	C1	R401	C2	R419	C1	XL202	C2
C215	B4	C232	D1	C249	D3	C266	A1	C285	B1	C303	B1	C323	B2	C342	B1	C359	D4	C376	C2	CN207	A4	FB202	B4	IC209	D4	MS203	A1	R223	A2	R241	A3	R258	B2	R274	A4	R291	C2	R308	D1	R329	B1	R350	B2	R367	A3	R385	C1	R402	C2	R420	D1	ZD202	B3
C216	B4	C233	C1	C250	D3	C267	A1	C286	A1	C304	B3	C324	B2	C343	C1	C360	D4	C377	C2	CN208	A4	FB203	D3	JK201	B1	Q201	A2	R225	A2	R242	A3	R259	B2	R275	A4	R292	C2	R309	C1	R330	B1	R351	B3	R368	B3	R386	C1	R403	D1	R422	C1		
C217	C1	C234	D1	C251	D3	C268	A1	C287	B1	C305	B3	C325	B2	C344	C1	C361	C4	C378	D2	CN209	A4	FB204	D4	JK202	C1	Q202	B4	R226	D4	R243	A3	R260	B2	R276	A4	R293	C2	R310	C1	R331	B1	R352	B3	R369	B3	R387	C1	R404	C2	R423	D2		
C218	C2	C235	D1	C252	D3	C269	A1	C288	A2	C306	B3	C326	B4	C345	C1	C362	C4	C379	C2	CN210	A4	FB206	B2	JK203	B1	Q203	A3	R227	D4	R244	A3	R261	B2	R277	A4	R294	C2	R311	C1	R332	D1	R353	B3	R370	B3	R388	C1	R405	C2	R424	C4		
C219	C2	C236	D1	C253	D3	C270	A1	C289	A3	C307	B3	C327	A4	C346	C2	C363	C4	C380	C2	CN212	C4	FB207	B4	JK204	D1	Q203	A3	R228	A2	R245	A3	R262	A3	R278	A4	R295	C3	R313	C1	R333	D1	R354	B3	R371	B3	R389	C1	R406	C2	R425	B3		

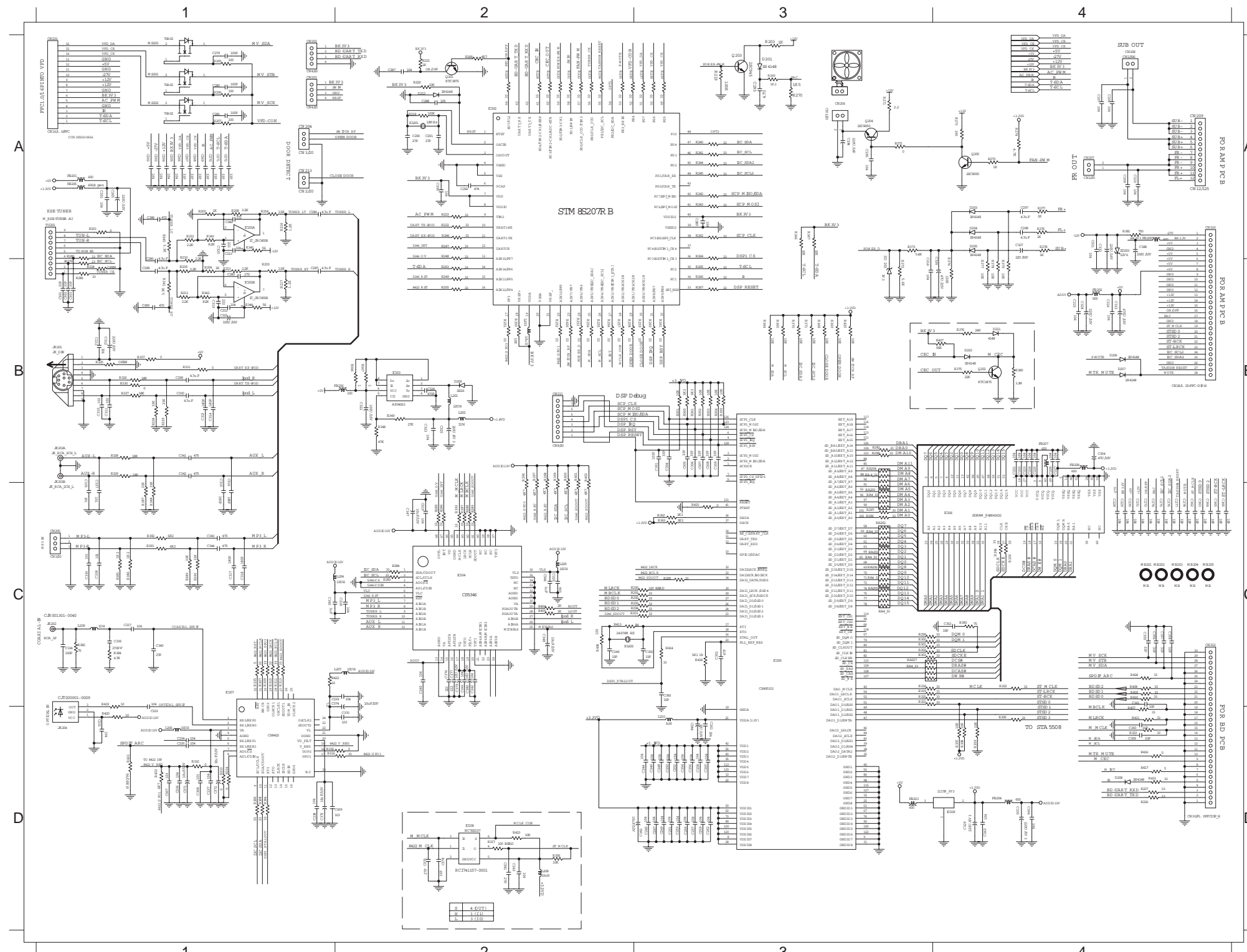

CIRCUIT DIAGRAM-(part two)

C101	A1	C106	A2	C111	B3	C116	C1	C121	B1	C126	B2	C131	C1	C136	C1	CN101	A2	CN106	C1	CN111	A3	FB102	A1	Q101	B1	R102	B1	R107	C2	R112	B2	R117	C2	R122	C2	SW101	A3	ZD101	B2
C102	A1	C107	A1	C112	B3	C117	C1	C122	B1	C127	C2	C132	C1	C137	C2	CN102	A2	CN107	A3	CN112	A3	IC101	C2	Q102	B2	R103	B1	R108	C2	R113	B2	R118	C2	R123	C2	SW102	A3	ZD101	B2
C103	C1	C108	A1	C113	B2	C118	C1	C123	C1	C128	C2	C133	C1	C138	C2	CN103	A2	CN108	A1	CN113	A3	JK101	A1	Q102	B2	R104	B1	R109	C2	R114	B2	R119	C2	R124	C2	SW103	A3		
C104	C2	C109	A1	C114	B1	C119	B2	C124	B2	C129	C3	C134	C1	C139	C2	CN104	A2	CN109	A1	DP101	B3	L101	A2	Q103	B2	R105	B1	R110	B2	R115	B2	R120	C2	R125	C1	USB101A1			
C105	A2	C110	A1	C115	C1	C120	B1	C125	B2	C130	C1	C135	C1	C140	C3	CN105	B1	CN110	A1	FB101	A1	L102	A2	R101	B1	R106	B1	R111	B2	R116	B2	R121	C2	SN101	B1	USB102A1			

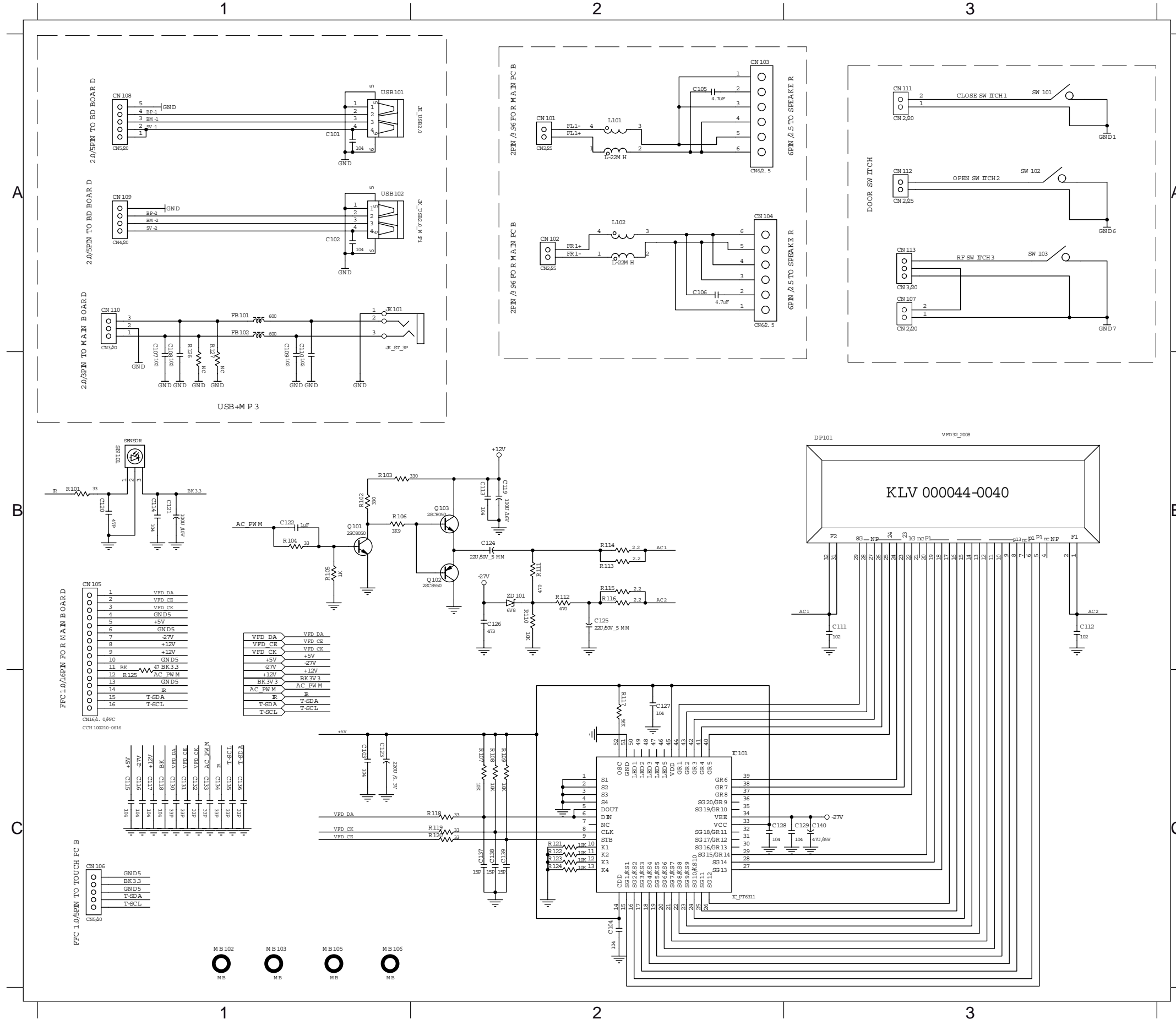

- MB102
- MB103
- MB105
- MB106

PCB LAYOUT - TOP VIEW

C105	A1	C206	B2	C240	B2	C288	B2	C311	B2	C330	B2	C346	B2	C380	B2	CN108B1	CN209C4	FB202B2	IC208	B4	L205	B2	R121	B4	R226	C3	R241	A2	R255	C3	R278	C3	R292	A4	R306	C2	R322	A4	R339	B2	R373	C2	R389	B2	R403	C2	R420	C2	SW101A4
C106	A1	C207	C2	C241	B2	C292	C2	C312	B2	C333	A3	C347	B2	C381	B3	CN109C1	CN210A3	FB203A2	IC209	A2	L206	C2	R122	B4	R227	C3	R242	C3	R256	C3	R279	A2	R293	A3	R307	C2	R323	C3	R340	B2	R374	C2	R390	B2	R404	B2	R422	C2	SW102A4
C119	A4	C211	B2	C242	B2	C294	A4	C313	B2	C334	B2	C348	B2	C382	A3	CN110B1	CN212B4	FB204A2	IC209	A2	L207	C2	R123	B4	R228	B3	R243	C3	R257	C3	R280	A2	R294	A4	R308	C2	R326	B2	R341	B2	R376	C3	R391	B2	R405	B2	R423	B4	SW103B1
C121	A4	C214	C2	C243	B3	C297	C3	C314	B2	C335	B2	C351	B3	C383	B3	CN111A4	CN213C3	FB206A3	IC209	A2	L209	C2	R124	B4	R229	B3	R244	C3	R258	C3	R281	A2	R295	A4	R309	C2	R327	B2	R346	A3	R377	B2	R392	B2	R406	B3	R424	C2	TU201A2
C123	C4	C215	B2	C261	A3	C298	C3	C315	B2	C336	B2	C353	A3	C384	B4	CN112A4	D203	C2	FB207A2	JK101B1	MS201A2	R203	A3	R230	B3	R245	C3	R259	C3	R282	B3	R296	B3	R310	C2	R328	B2	R347	A3	R378	C2	R393	B2	R407	C3	R426	C3	USB101B1	
C124	B4	C216	A3	C264	B2	C299	B2	C316	B2	C337	B2	C354	A2	C387	C3	CN113C1	D204	C2	FB208A2	JK201B1	MS202A2	R205	A3	R232	B3	R246	C2	R260	C3	R283	B2	R297	B3	R311	C2	R329	B2	R349	A3	R379	C2	R394	C2	R408	B3	R427	B3	USB102C1	
C125	B4	C217	C2	C265	A2	C300	B2	C317	B2	C338	B2	C371	C2	C388	A2	CN201A2	D205	C2	FB209A3	JK202B2	MS203A3	R206	A2	R233	B3	R247	C2	R261	C3	R284	B2	R298	C3	R313	C2	R330	B2	R350	C2	R380	B3	R395	A4	R409	B4	RA201A3	XL201B2		
C133	A4	C218	B2	C279	A3	C304	B3	C318	B2	C339	C2	C372	C2	CN101A1	CN202C3	D206	C3	IC202	B3	JK203A2	Q102	A4	R207	A2	R234	B3	R248	C2	R262	C3	R285	C2	R299	C3	R315	A3	R331	B2	R356	B4	R382	C2	R396	C2	R410	C3	RA202A3	XL202B4	
C134	A4	C219	B2	C280	A2	C305	B3	C322	A3	C340	C2	C373	C2	CN102A1	CN203C2	D209	A3	IC203	A3	JK204C1	Q102	A4	R219	A3	R235	B3	R249	C2	R264	C3	R286	C2	R300	A3	R316	C2	R333	C2	R357	A3	R383	A3	R397	B2	R411	C3	RA203B3	ZD202C2	
C135	A4	C220	B2	C281	A2	C306	B3	C325	A3	C341	B2	C374	C2	CN103A1	CN204C3	D210	B3	IC204	B2	L101	A1	Q103	A4	R220	C2	R236	B3	R250	C2	R267	C3	R287	B2	R301	A3	R317	B4	R334	C2	R358	A4	R384	C2	R398	C2	R412	C3	RA204B3	
C136	A4	C222	A3	C284	B2	C307	B3	C326	C2	C342	B2	C375	B3	CN104A1	CN205A2	D211	B3	IC205	A3	L102	A1	Q201	B3	R221	B3	R237	B3	R251	C2	R268	B3	R288	B2	R302	A3	R318	A4	R335	C2	R359	A4	R385	B2	R399	A3	R414	B3	RA205A3	
C140	A4	C233	C2	C285	A2	C308	B3	C327	C2	C343	B2	C376	B2	CN105A4	CN206A4	D212	C2	IC206	A3	L201	A3	Q202	B3	R222	C2	R238	B3	R252	C3	R273	A4	R289	B3	R303	A3	R319	A3	R336	C2	R362	A3	R386	B2	R400	B2	R415	A4	RA206A3	
C201	A2	C234	C2	C286	B2	C309	B3	C328	B2	C344	B2	C377	B2	CN106A4	CN207C3	DP101B4	IC206	A3	L203	C3	Q203	A4	R223	B3	R239	B3	R253	C3	R276	C3	R290	A3	R304	A3	R320	A3	R337	B2	R363	A3	R387	B2	R401	B2	R417	C3	RA207B3		
C204	B2	C235	C2	C287	B2	C310	B2	C329	A2	C345	B2	C379	B2	CN107B1	CN208C3	FB201A2	IC207	C2	L204	B2	Q203	A4	R225	B3	R240	B3	R254	C3	R277	C3	R291	A3	R305	B3	R321	A3	R338	B2	R372	C2	R388	B2	R402	C2	R419	C2	SN101A4		

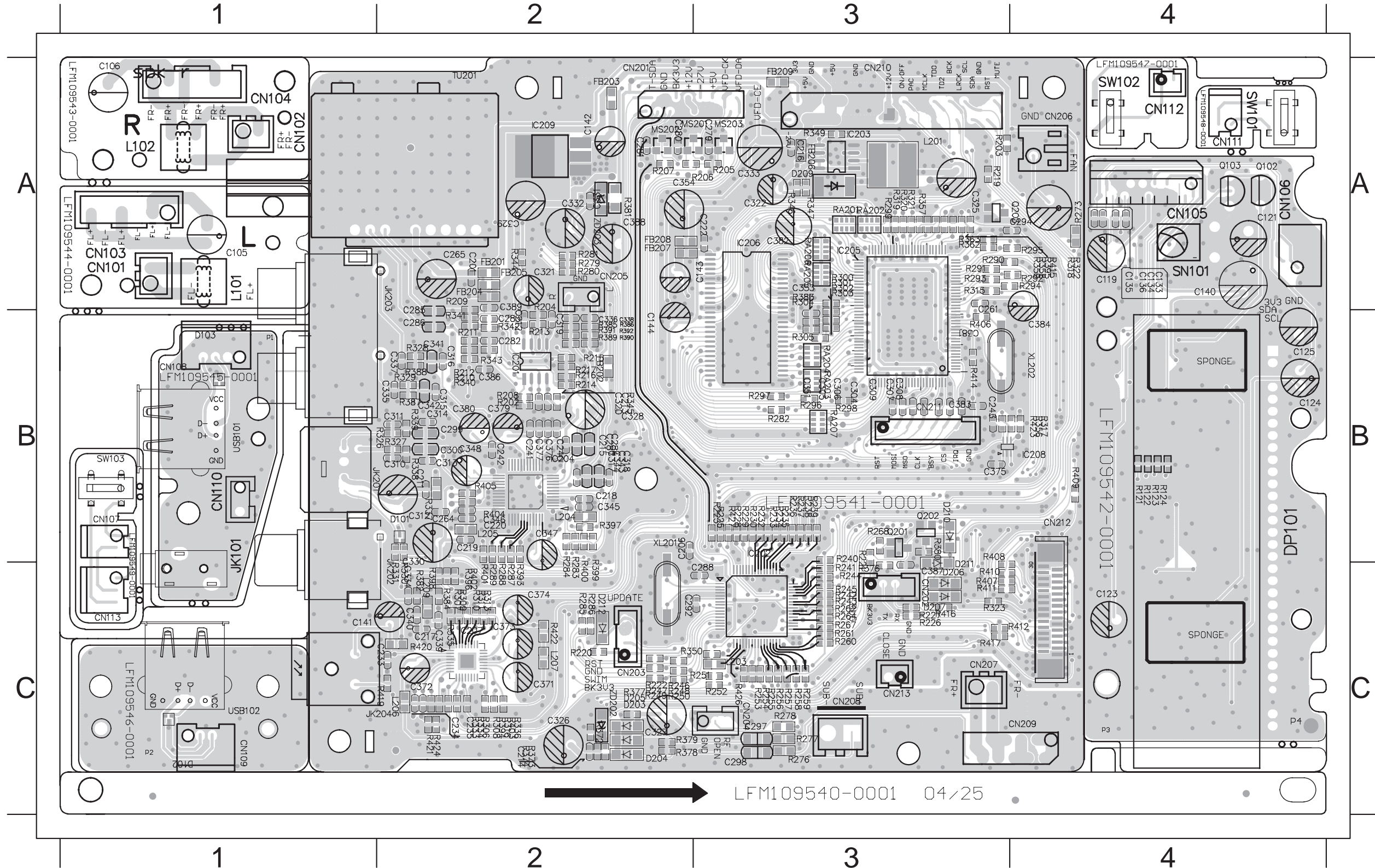

PCB LAYOUT - BOTTOM VIEW

C101 B1 C111 C4 C120 A4 C132 A4 C207 C3 C226 A3 C237 C2 C249 A2 C257 A3 C268 A3 C276 A3 C301 A2 C355 B3 C363 A3 C378 B4 L210 B3 R105 B4 R113 C4 R125 A4 R270 A3 R351 B3 R365 C3 R413 B3
 C102 C1 C112 B4 C122 B4 C137 B4 C208 C3 C227 A3 C238 C2 C250 A3 C258 B3 C269 A2 C277 A3 C302 A2 C356 C4 C364 A3 D201 A4 Q101 B4 R106 B4 R114 C4 R201 A1 R271 A4 R352 B3 R366 C3 R418 A3
 C103 C4 C113 A4 C126 B4 C138 B4 C209 C4 C228 A3 C239 C2 C251 A3 C259 B3 C270 A2 C278 A3 C303 A2 C357 C4 C365 A3 D208 C3 Q204 A4 R107 B4 R115 B4 R218 C2 R271 A4 R353 B4 R367 C3 R425 C3
 C104 B4 C114 A4 C127 C4 C139 B4 C210 C3 C229 A3 C244 A3 C252 A3 C260 A3 C271 A2 C289 C3 C323 A3 C358 C4 C366 A3 FB101B1 Q205 A4 R108 B4 R116 B4 R231 C3 R272 A4 R354 B3 R368 C3 ZD101B4
 C107 B1 C115 A4 C128 B4 C202 A3 C221 A3 C230 A3 C245 B3 C253 A3 C262 B3 C272 A2 C290 C2 C324 A3 C359 C4 C367 C2 FB102B1 R101 A4 R109 B4 R117 B4 R263 C3 R274 A4 R355 B3 R369 C3 ZD101B4
 C108 B1 C116 A4 C129 C4 C203 A3 C223 B3 C231 A3 C246 A3 C254 B3 C263 A2 C273 A3 C291 C2 C349 B3 C360 C4 C368 C2 IC101C4 R102 B4 R110 A4 R118 B4 R265 C3 R275 A4 R360 B3 R370 C3
 C109 B1 C117 A4 C130 A4 C204 A3 C224 A3 C232 C2 C247 B3 C255 A3 C266 A3 C274 A3 C293 A3 C350 B3 C361 C4 C369 C2 L202 A3 R103 A4 R111 B4 R119 B4 R266 C3 R332 C2 R361 B3 R371 C3
 C110 C1 C118 A4 C131 A4 C205 A2 C225 A3 C236 C2 C248 B3 C256 B3 C267 A3 C275 A3 C295 A4 C352 B3 C362 A3 C370 C2 L208 B3 R104 B4 R112 B4 R120 B4 R269 A3 R348 A3 R364 C3 R375 B3

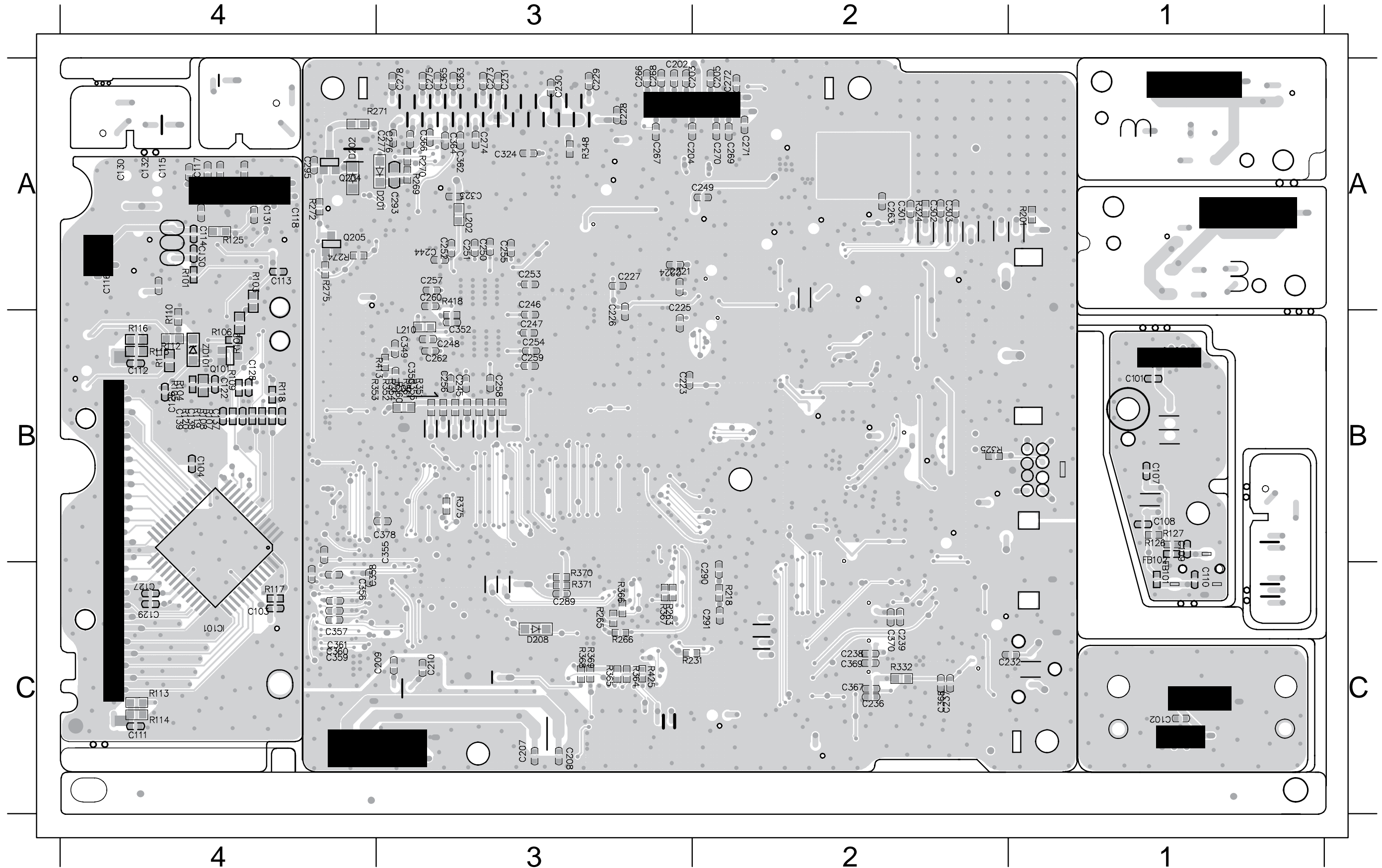

POWER & AMP BOARD

TABLE OF CONTENTS

- Internal IC Diagram 7-1
- Circuit Diagram (AMP)..... 7-2
- Circuit Diagram (power)..... 7-3
- PCB Layout Top View 7-4
- PCB Layout Bottom View 7-5

INTERNAL IC DIAGRAM - TAS5508BPAG

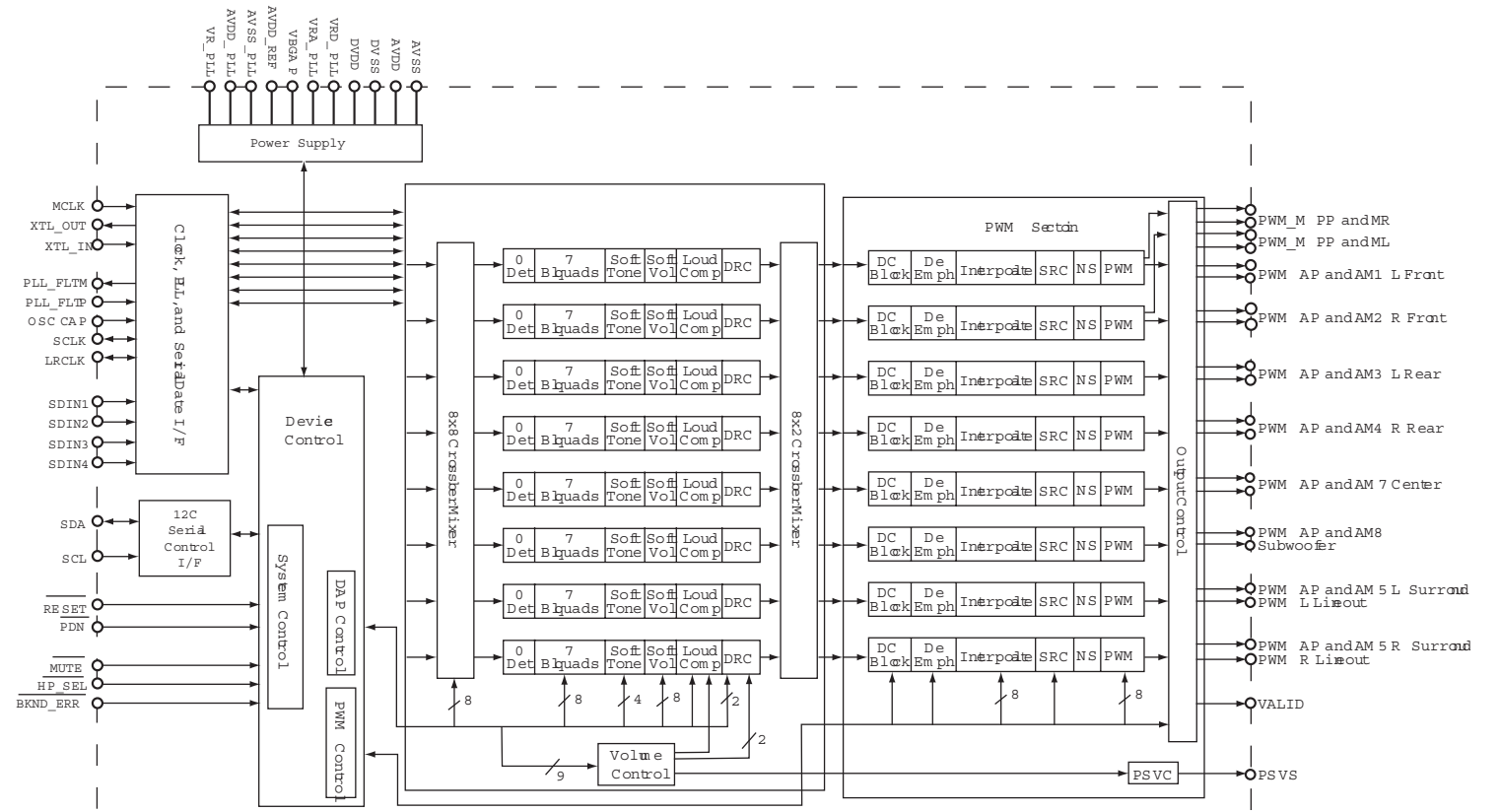

INTERNAL IC DIAGRAM - TAS5342ADD

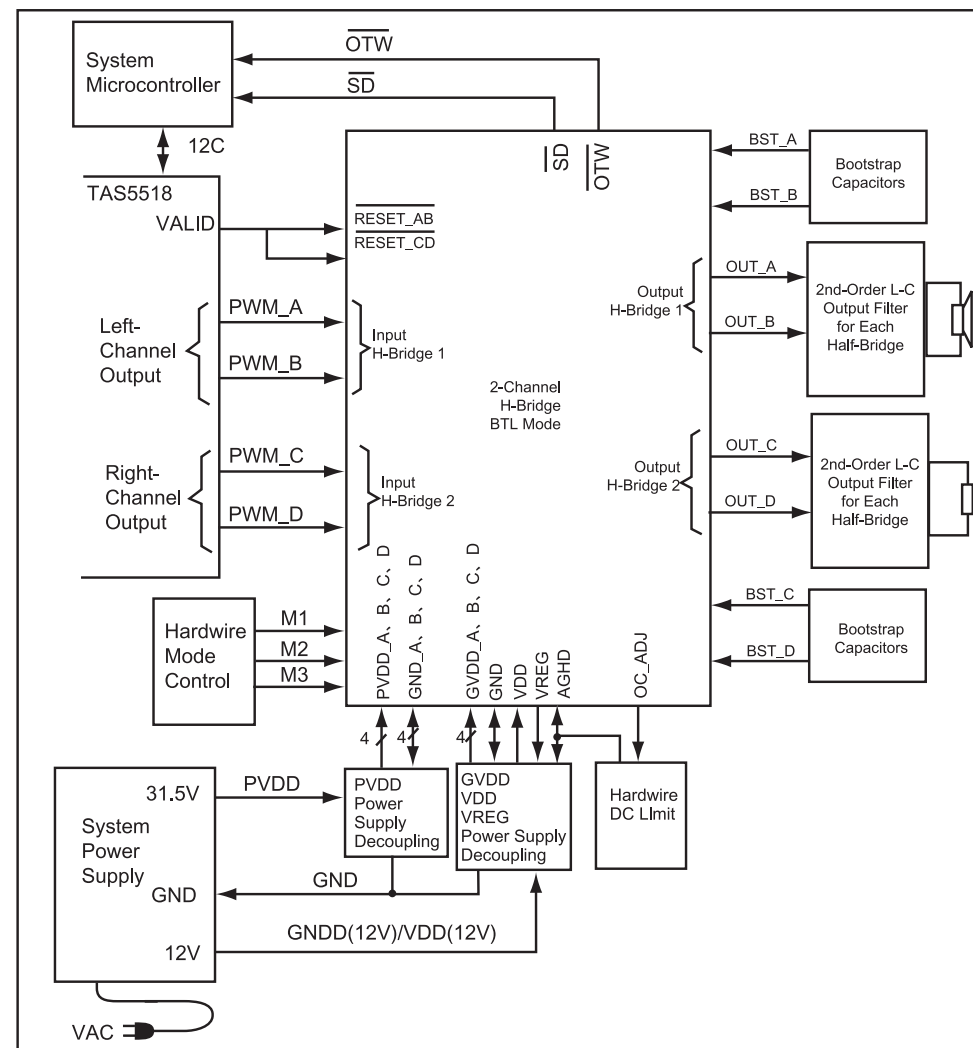

CIRCUIT DIAGRAM - (AMP)

C701 A2 C709 A2 C717 A2 C725 A2 C733 C2 C741 A1 C749 B3 C757 B4 C765 B3 C773 A2 C781 C2 C789 C3 C797 C3 C805 C1 C813 C2 FB701A2 L704 A3 R702 A2 R710 B1 R718 B3 R728 C4 R736 B2 R748 B4 R756 C3 R764 B3 XL701C3
 C702 A2 C710 A2 C718 A3 C726 A2 C734 A2 C742 A2 C750 A3 C758 B1 C766 C4 C774 A3 C782 C3 C790 C3 C798 C3 C806 C2 C814 C3 FB702A2 L705 A3 R703 A2 R711 A3 R721 B2 R729 C4 R739 B2 R749 C1 R757 C3 R766 C1
 C703 A2 C711 A3 C719 A3 C727 A2 C735 A2 C743 A2 C751 B3 C759 B1 C767 C3 C775 A3 C783 C3 C791 C3 C799 C1 C807 C2 C815 C3 IC701B1 L706 A4 R704 A2 R712 B3 R722 B2 R730 C4 R740 B4 R750 C2 R758 C3 R767 C2
 C704 A2 C712 A4 C720 A3 C728 C1 C736 A2 C744 A4 C752 A3 C760 C2 C768 C4 C776 A4 C784 C3 C792 C3 C800 C1 C808 C2 CN701A1 IC702A3 Q701 C2 R705 A3 R713 A3 R723 B2 R731 C4 R741 B2 R751 B2 R759 C3 R768 C2
 C705 A3 C713 A2 C721 A4 C729 C1 C737 A2 C745 A1 C753 B3 C761 C2 C769 C4 C777 A4 C785 C3 C793 C3 C801 C1 C809 C2 CN702A1 IC703A3 Q702 C2 R706 A3 R714 B3 R724 B3 R732 C4 R743 B3 R752 C2 R760 B3 R769 C2
 C706 A4 C714 A2 C722 A4 C730 C1 C738 A4 C746 A1 C754 B4 C762 C3 C770 C4 C778 A4 C786 C3 C794 C3 C802 C1 C810 C2 CN703B1 L701 A1 Q703 C2 R707 A4 R715 B4 R725 B3 R733 C4 R744 B4 R753 C2 R761 B3 R770 C3
 C707 A2 C715 A3 C723 A1 C731 C2 C739 A4 C747 B1 C755 B4 C763 C3 C771 A1 C779 B1 C787 C3 C795 C3 C803 C1 C811 C2 CN704B1 L702 A2 Q704 C2 R708 A1 R716 A4 R726 C3 R734 C4 R745 B4 R754 C2 R762 B3 R773 C2
 C708 A2 C716 A2 C724 A2 C732 C2 C740 A4 C748 B2 C756 A4 C764 C3 C772 A2 C780 C2 C788 B3 C796 C3 C804 C1 C812 C2 D702 C2 L703 A2 R701 A2 R709 A1 R717 B2 R727 B3 R735 C4 R746 C4 R755 C3 R763 B3 R774 C2

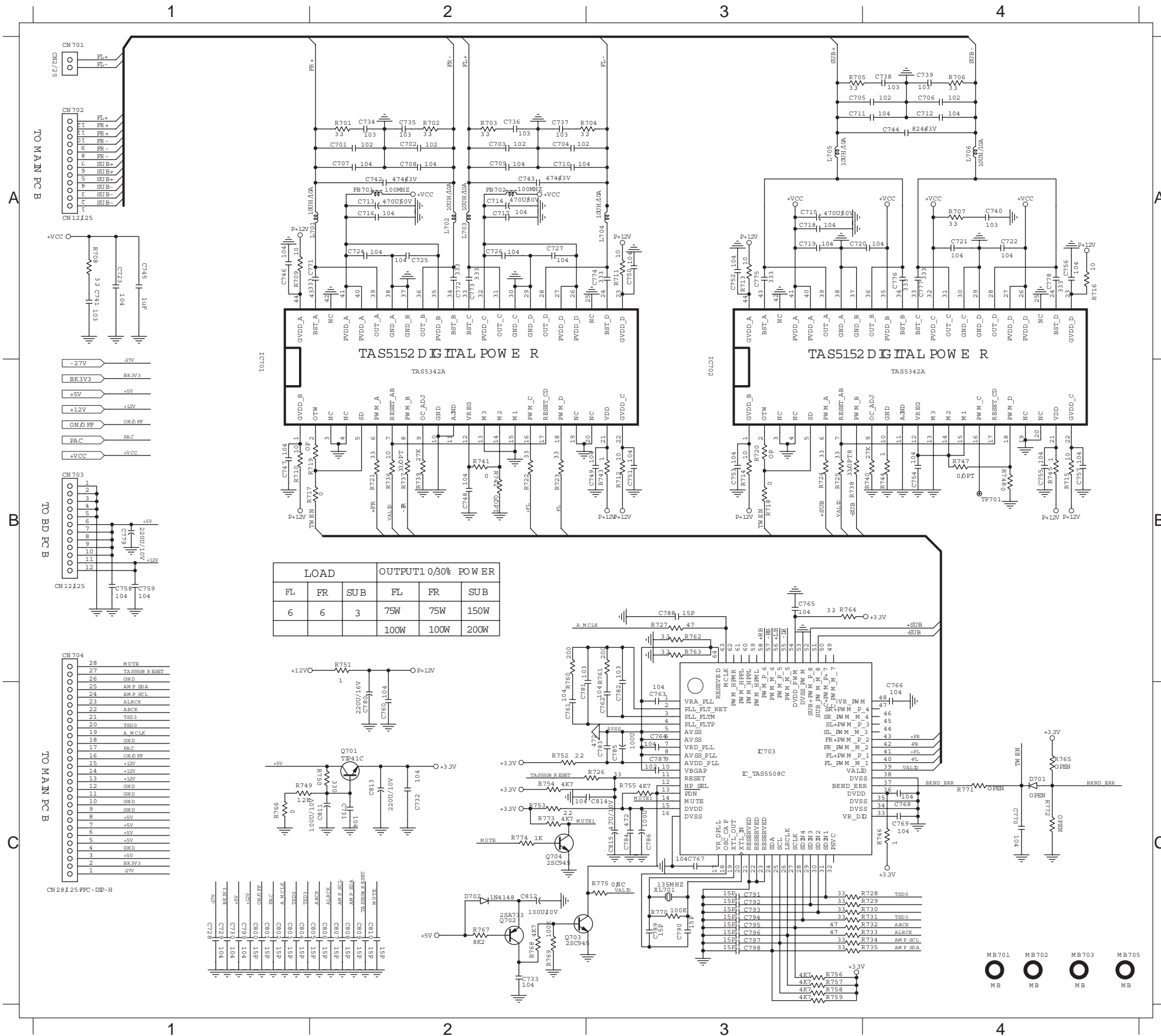

CIRCUIT DIAGRAM - (power)

BD901A1 C912 C3 C927 C3 C948 B3 C960 C3 C970 A3 C990 A2 CN902A1 D905 B2 D915 B4 D928 B4 IC903 C2 LF902 B1 Q909 C2 R902 B1 R908 B3 R919 A4 R930C2 R931 B4 R9402 B2 R9456 A3 R947 C3 R961 B4 R971 A3 R981 C2 R992 C3 TVR901C1 ZD909 A4
C901 C3 C913 C4 C928 C3 C949 A3 C961 C3 C971 A3 C991 B3 CX901B1 D906 A2 D916 B3 D930 A2 IC904 C3 NTC901C1 Q910 B3 R902AC4 R909 A3 R920 C2 R9301 C2 R932 A2 R9403 B2 R9457 A3 R948 C3 R962 C3 R972 A3 R982 B4 R993 C4 TVR902A1 ZD910 A4
C902 C1 C914 C3 C929 B3 C950 A3 C962 B3 C972 A3 C993 C4 CX902B1 D907 B3 D917 B2 D931 B2 IC905 B4 Q901 B3 Q911 C3 R9302 C2 R933 C2 R941 B2 R9458 A3 R949 A2 R963 B3 R973 A3 R983 B3 R994 C4 TVR903A1 ZD913 A3
C903 C1 C915 B3 C930 B4 C951 A3 C963 B3 C973 C4 C994 A2 CY903B1 D908 A3 D918 B2 D934 A4 IC906 C4 Q902 C4 Q912 A2 R903AC3 R911 B4 R923 C3 R9303 C2 R934 B1 R942 B2 R9459 A3 R950 C3 R964 B4 R974 A4 R984 C4 R995 B4 ZD901 B3
C904 A1 C917 A4 C931 C3 C953 C4 C964 B4 C974 B4 C997 C1 CY904B1 D909 A3 D919 C3 F901 C1 L904 C3 Q903 B4 Q913 A2 R904 B1 R912 B1 R924 B1 R9304 C2 R935 C1 R9450 A3 R9460 A3 R952 B3 R965 A3 R975 A4 R985 B3 R997 B4 ZD902 C2
C905 A1 C918 B3 C936 B2 C954 C4 C965 A3 C975 B4 C998 C4 CY905C1 D910 A4 D920 B3 GT902B1 L905 B3 Q904 C3 Q915 B3 R904AC3 R914 A4 R925 C3 R9305 C2 R936 C2 R9451 A3 R9461 A3 R953 B3 R966 A3 R976 A4 R986 B4 R998 B4 ZD903 B2
C906 B3 C922 C2 C938 C2 C955 B3 C966 B4 C978 C2 CE901A1 CY906C1 D911 A3 D921 B3 GT903C2 L906 C3 Q905 B3 Q917 C4 R905 B1 R915 A1 R926 A4 R9306 C2 R937 B2 R9452 A3 R9462 A3 R954 C3 R967 A3 R977 B4 R987 B3 R999 B4 ZD904 A2
C909 C4 C923 C3 C941 B2 C956 C3 C967 A4 C976 B4 CE902A1 D902 C4 D912 A4 D922 C3 GT904A2 L907 A3 Q906 C3 Q995 B4 R905AB3 R916 A1 R927 C3 R9307 C2 R938 B3 R9453 A3 R9463 A3 R955 C3 R968 A4 R978 C4 R989 A4 T901 B2 ZD905 A3
C910 B3 C924 C3 C946 A2 C957 A4 C968 A3 C981 B4 CM901A2 D903 B2 D913 A4 D923 B3 GT905B2 L908 A3 Q907 C3 R901 B3 R906 B3 R917 A1 R928 C2 R9308 C2 R940 B2 R9454 A3 R9464 A3 R956 B3 R969 A4 R979 B4 R990 C3 T902 B2 ZD907 B4
C911 B2 C925 C3 C947 C3 C958 A4 C969 A3 C985 C2 CN901C1 D904 C2 D914 A4 D924 A3 IC901 C1 LF901 B1 Q908 B3 R901AC4 R907 B3 R918 A1 R929 C3 R9309 C2 R9401 B2 R9455 A3 R9465 A3 R960 A4 R970 A4 R980 B4 R991 C3 T903 A2 ZD908 A4

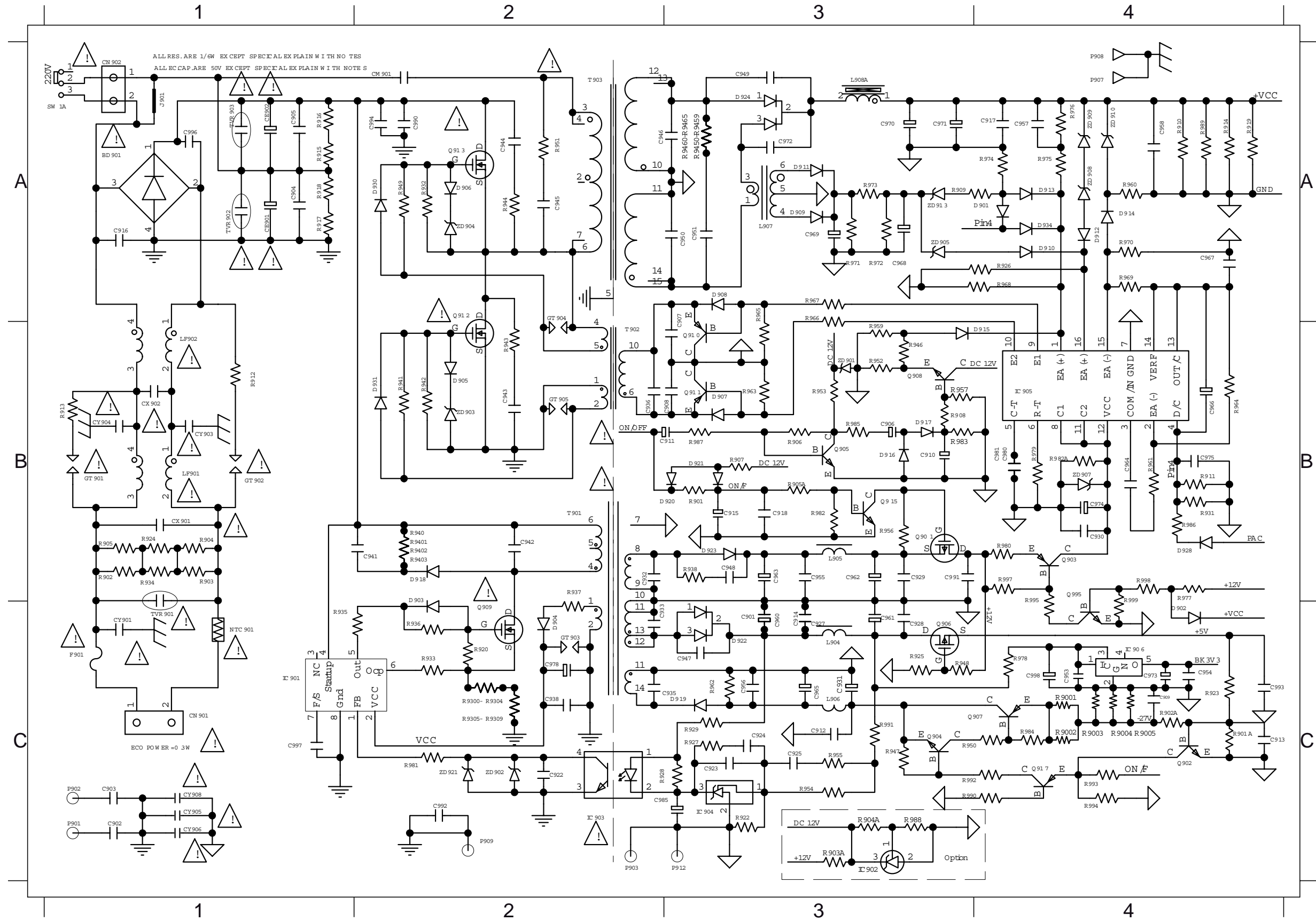

PCB LAYOUT - TOP VIEW

BD901 A1 C722 B4 C742 C4 C750 B3 C761 A4 C769 A4 C777 B4 C788 B4 C910 B3 C961 A3 C971 C3 CE902A1 CX901C1 D907 B3 D924 C3 GT904B2 IC905 B3 L905 B3 Q702 A4 Q912 B2 R713 B4 R723 B4 R731 A4 R741 B4 R753 A4 R774 B4 T901 A2
 C713 C4 C723 C4 C743 C3 C751 B3 C762 A4 C770 B4 C778 B4 C811 A4 C911 B3 C962 B3 C973 A3 CM901B1 CX902B1 D908 B3 D930 B2 GT905B2 L701 C4 L906 A3 Q703 A4 Q913 B2 R714 B4 R724 B4 R732 A4 R743 B4 R754 A4 R912 B1 T902 B2
 C714 C3 C724 B4 C744 C4 C752 B4 C763 B4 C771 B4 C779 A4 C812 A4 C915 B3 C963 A3 C974 B3 CN701C3 CY903B1 D909 B2 D931 B2 HT901A1 L702 C4 L907 B3 Q704 B4 R707 C4 R715 B4 R725 B4 R733 A4 R744 B4 R755 A4 R929 A2 T903 B2
 C715 B4 C725 B4 C745 C4 C753 B4 C764 A4 C772 B4 C780 B4 C813 A4 C923 A2 C965 A3 C978 A2 CN702C4 CY904B1 D911 B2 F901 C1 HT902B3 L703 C3 L908 C3 Q903 B3 R708 C4 R716 B4 R726 A4 R734 A4 R745 B4 R760 A4 R937 A2 TVR901C1
 C718 C4 C726 B4 C746 B4 C754 B4 C765 B4 C773 B4 C781 A4 C815 A4 C931 A3 C966 B3 C985 A2 CN703A3 CY905A2 D918 A2 FB701B4 IC701 B3 L704 C4 LF901 B1 Q907 A3 R709 B4 R717 B4 R727 B4 R735 A4 R746 B4 R761 A4 R940A2 TVR902A1
 C719 B4 C727 B4 C747 B4 C755 B4 C766 B4 C774 B3 C782 A4 C901 A3 C941 A2 C968 B3 C997 A2 CN704A4 CY906B2 D919 A3 FB702C3 IC702 B4 L705 C4 LF902 B1 Q909 A2 R710 B4 R718 B4 R728 A4 R736 B4 R748 B4 R764 B4 R940A2 TVR903B1
 C720 B4 C740 C4 C748 B4 C756 B4 C767 A4 C775 B4 C785 A4 C902 C2 C951 C3 C969 B2 C998 A3 CN901C1 D702 A4 D922 A3 GT902C1 IC703 B4 L706 C4 NTC901C1 Q910 B3 R711 B3 R721 B4 R729 A4 R739 B4 R751 A3 R767 A4 R941 B2 XL701A4
 C721 B4 C741 C4 C749 B4 C757 B4 C768 A4 C776 B4 C786 A4 C906 B3 C960 A3 C970 C3 CE901A1 CN902A1 D904 A2 D923 B3 GT903A2 IC904 A2 L904 A3 Q701 A4 Q911 B3 R712 B3 R722 B4 R730 A4 R740 B4 R752 A4 R773 A4 R949 B2

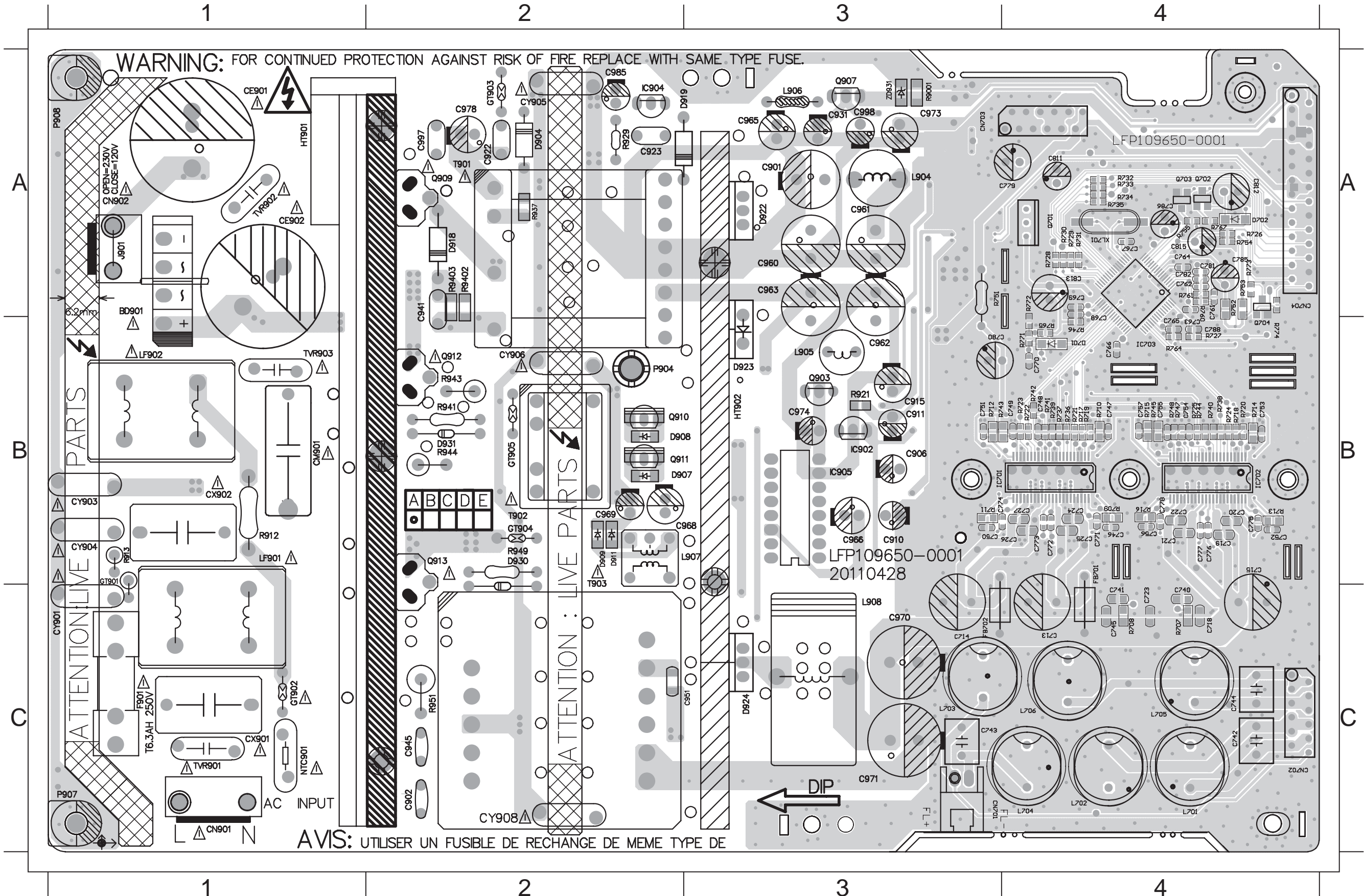

PCB LAYOUT - BOTTOM VIEW

C701	C4	C711	C4	C734	C4	C784	A4	C797	A4	C807	A4	C913	A3	C936	B2	C956	A3	C991	A3	D914	B3	IC906	A3	R701	C4	R758	A4	R902	C1	R908	B3	R920	A2	R9302A1	R933	A2	R9452C3	R9461C3	R954	A3	R967	B2	R977	B3	R987	B3	R999	B3	ZD913B2
C702	C4	C712	C4	C735	C4	C787	A4	C798	A4	C808	A4	C914	A3	C938	A2	C957	C3	C993	A3	D915	C3	Q901	A3	R702	C4	R759	A4	R902AA3	R909	B3	R922	A2	R9303A1	R934	C1	R9453C3	R9462C3	R955	A3	R968	B3	R978	A3	R989	C3	ZD901B3			
C703	C3	C716	B4	C736	C3	C789	A4	C799	A4	C809	A4	C917	C3	C946	C2	C958	C3	C994	B2	D916	B3	Q902	A3	R703	C3	R762	A4	R903	C1	R910	C3	R923	A3	R9304A1	R935	A2	R9454C3	R9463C3	R956	B3	R969	B3	R979	B3	R990	A3	ZD902A2		
C704	C3	C717	B3	C737	C4	C790	A4	C800	A4	C810	A4	C918	B3	C947	A3	C964	B3	D902	C3	D917	B3	Q904	A3	R704	C3	R763	A4	R903AB3	R911	B3	R924	C1	R9305A1	R936	A2	R9455C3	R9464C3	R960	C3	R970	B3	R980	B3	R991	A3	ZD903B2			
C705	C4	C728	A4	C738	C4	C791	A4	C801	A4	C814	A4	C924	A2	C948	B3	C967	B3	D903	A2	D920	B3	Q905	B3	R705	C4	R766	A4	R904	C1	R914	C3	R925	A3	R9306A1	R938	B3	R9456C3	R9465C3	R961	B3	R971	B2	R981	A2	R992	A3	ZD904B2		
C706	C4	C729	A4	C739	C4	C792	A4	C802	A4	C903	A1	C925	A3	C949	C3	C972	C3	D905	B2	D921	B3	Q906	A3	R706	C4	R768	A4	R904AB3	R915	A1	R926	B3	R9307A1	R940	A2	R9457C3	R947	A3	R962	A3	R972	B2	R982	B3	R993	A3	ZD905B2		
C707	C4	C730	A4	C758	A4	C793	A4	C803	A4	C904	A1	C927	A3	C950	C2	C975	B3	D906	C2	D928	B3	Q908	B3	R749	A4	R769	A4	R905	C1	R916	A1	R927	A2	R9308A1	R9401A2	R9458C3	R948	A3	R963	B2	R973	B2	R983	B3	R994	A3	ZD907B3		
C708	C4	C731	A4	C759	A4	C794	A4	C804	A4	C905	A1	C928	A3	C953	A3	C980	B3	D910	B3	D934	B3	Q915	B3	R750	A4	R770	A4	R905AB3	R917	A1	R928	A2	R9309A1	R942	B2	R9459C3	R950	A3	R964	B3	R974	C3	R984	A3	R995	B3	ZD908C3		
C709	C3	C732	A4	C760	B4	C795	A4	C805	A4	C909	A3	C929	A3	C954	A3	C981	B3	D912	C3	IC901	A2	Q917	A3	R756	A4	R901	B3	R906	B3	R918	A1	R9300A1	R931	B3	R9450C3	R946	B3	R952	B3	R965	B2	R975	C3	R985	B3	R997	B3	ZD909C3	
C710	C3	C733	A4	C783	A4	C796	A4	C806	A4	C912	A3	C930	B3	C955	A3	C980	B1	D913	B3	IC903	A2	Q995	B3	R757	A4	R901AA3	R907	B3	R919	C3	R9301A1	R932	C2	R9451C3	R9460C3	R953	B3	R966	B2	R976	C3	R986	B3	R998	B3	ZD910C3			

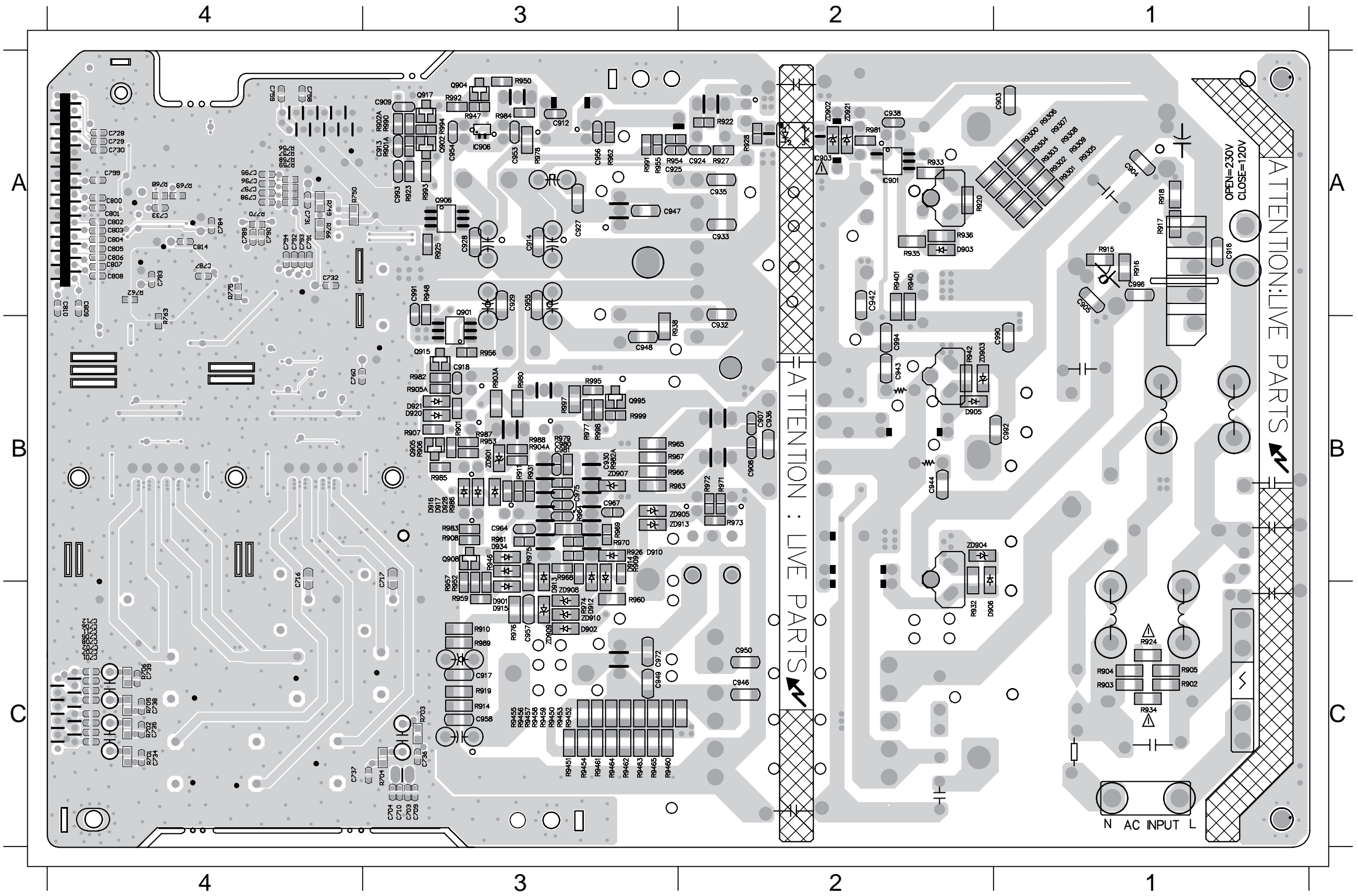

BD BOARD

TABLE OF CONTENTS

Block Diagram(BD Board) 8-1
 Voltages for connector pin..... 8-2
 Waveforms for measure point 8-3

BLOCK DIAGRAM

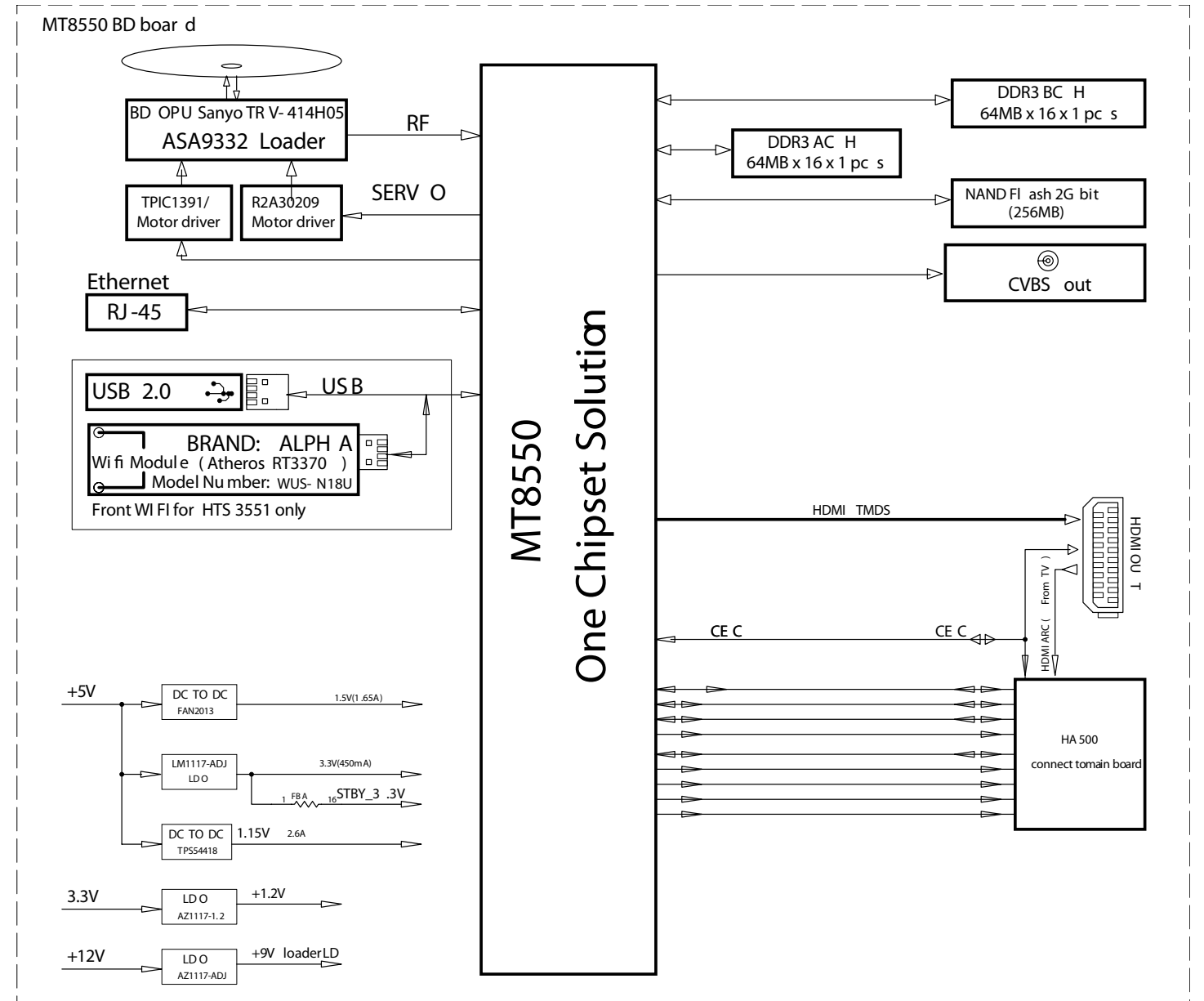

Voltages for per connection pin

1. HA500--->>from BD board connect to main board

PIN NO	PIN Assign	Remarks
1	GND	
2	IPOD_TXD	
3	IPOD_RXD	
4	GND	
5	IR	
6	GND	
7	I2C_IRQ	
8	GND	
9	CEC	
10	AMUTE	
11	GND	
12	SCL	
13	SDA	
14	GND	
15	MCLK	
16	GND	
17	LRCK	
18	GND	
19	BCK	
20	GND	
21	DATA0	
22	DATA1	
23	DATA2	
24	GND	
25	HDMI_ARC	
26	GND	
27	V_DATA	N/A
28	V_STB	N/A
29	V_SCLK	N/A
30	GND	

2. CN202--->>from BD board connect to USB connect PCB

PIN NO	PIN Assig	Remarks
1	USB+5V	4.75V-5.25V
2	USB+5V	
3	USBP	High speed
4	USBM	difference
5	GND	

3. J507 --->>from BD board connect to BD loader(SERVO use)

PIN NO	PIN Assign	Remarks
1	A+	0-11.6V
2	A-	0-11.6V
3	B-	0-1.6V
4	B+	0-1.6V
5	U	4.52V
6	V	4.52V
7	W	4.52V
8	COMMON	4.52V

4. HA801---->>from BD board connect to BD loader(SERVO use)

PIN NO	PIN Assign	Remarks
	Disc type voltage	CD DVD BD
1	FOC2+	2.66V 2.4V 2.68v
2	FOC2-	2.49V 2.8V 2.52v
3	TR-	2.58V 2.59V 2.55v
4	FOC1+	2.66V 2.59V 2.7v
5	TR+	2.59V 2.62V 2.58v
6	FOC1-	2.48V 2.66V 2.52v
7	A-	0.49V 0.26V 0.48v
8	B-	0.49V 0.35V 0.4v
9	A+	0.72V 0.26V 0.42v
10	B+	0.72V 0.35V 0.4v
11	GND	GND
12	SIG_PO	n/a
13	GND	GND
14	B	2.22V 2.05V 2.36V
15	A	2.22V 2.05V 2.44V
16	D	2.26V 2.05V 2.45V
17	C	2.23V 2.06V 2.31V
18	G	2.09V 1.9V 2.37V
19	H	2.09V 1.9V 2.30V
20	F	2.09V 1.88V 2.43V
21	E	2.09V 1.9V 2.24V
22	LDO_SDIO	2.35V 2.15V 0V
23	RFO+	3.11V 2.82V 2.72V
24	RFO-	2.11V 1.92V 2.54V
25	LDO_CLK	3.25V 3.04V 0V
26	LDO_SEN	3.25V 3.02V 3.3V
27	HAVC	2.09V 1.8V 2.1V
28	VCC_PDIC	4.95V
29	GND	GND
30	GAIN_SW	3.25V 0V 1.65V
31	GND	GND
32	BD_LD	0V 0V 4.54V
33	CD_LD	1.74V 0V 0V
34	DVD_LD	0V 1.96V 0V
35	GND	GND
36	AUX1	1.55V 1.23V 1.48V
37	VCC_HFM	4.92V
38	MDI_DVD	0.15V 0V 0.15V
39	MDI_BD	0V 0V 0.08V
40	DVD_VR	0.15V 0V 0.15V
41	CD_VR	0V 0V 0V
42	DVD_HFM	0V 0V 0V
43	CD_HFM	0V 0V 0V
44	GND	GND
45	GND	GND

5. J508 --->>from BD board connect to BD loader(SERVO use)

PIN NO	PIN Assign	Remarks
1	LOAD-	0.65V
2	LOAD+	0.65V
3	GND	GND
4	TRAY_IN	0V-->>open/close 3.3V
5	TRAY_OUT	N/A

Waveforms for measure point

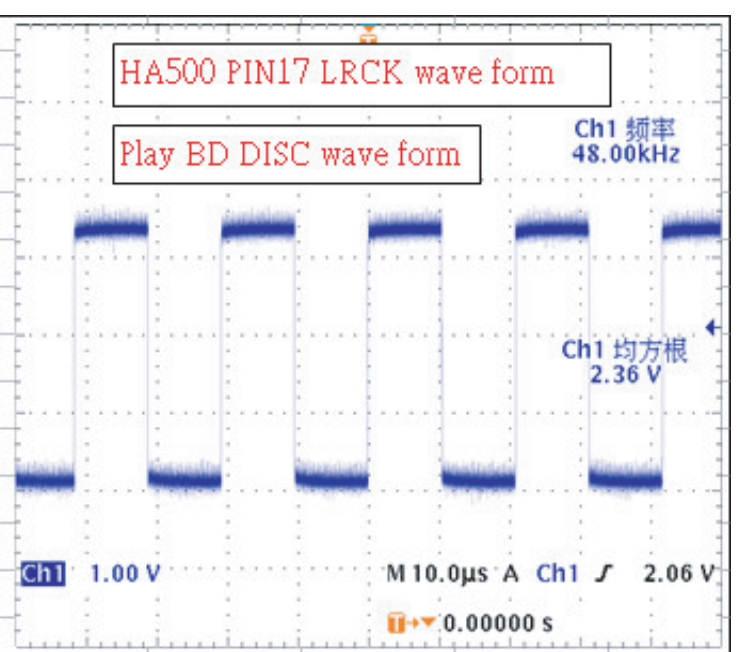
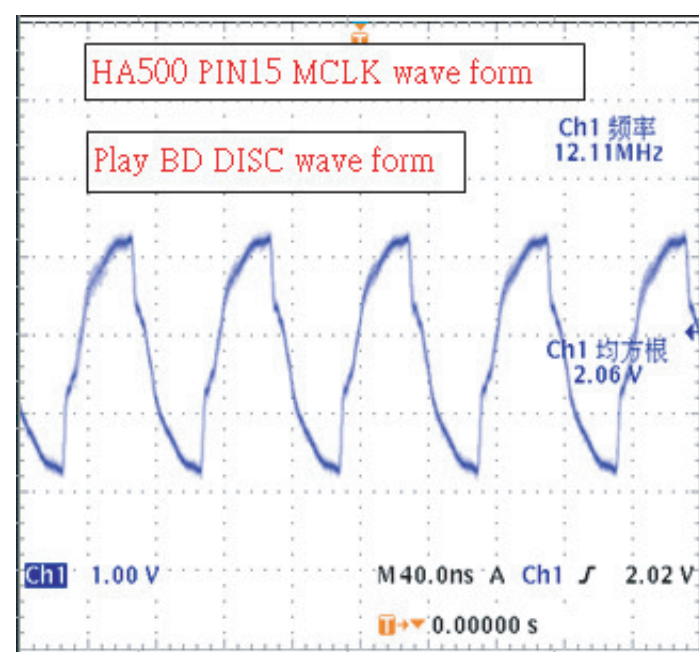
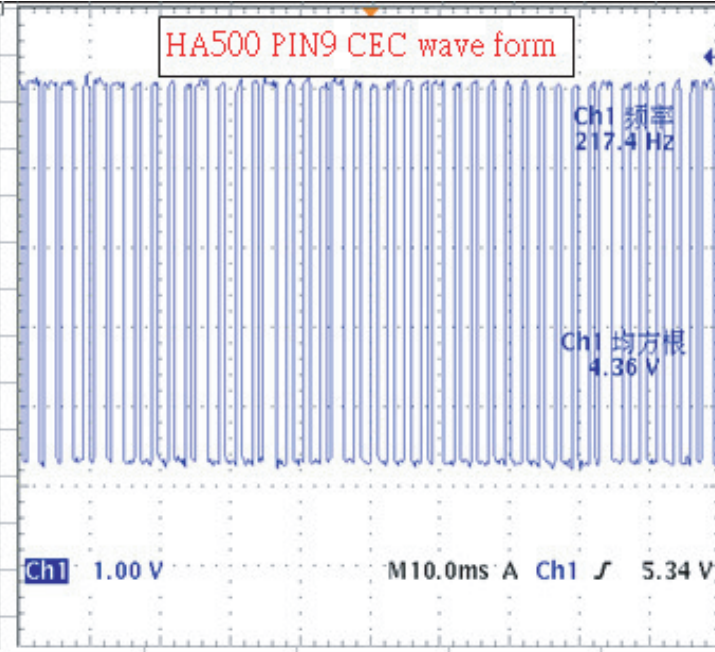
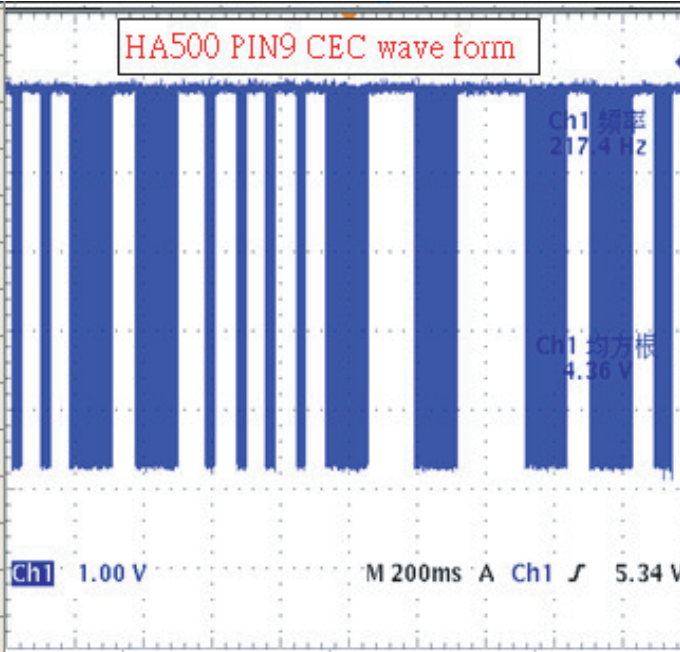
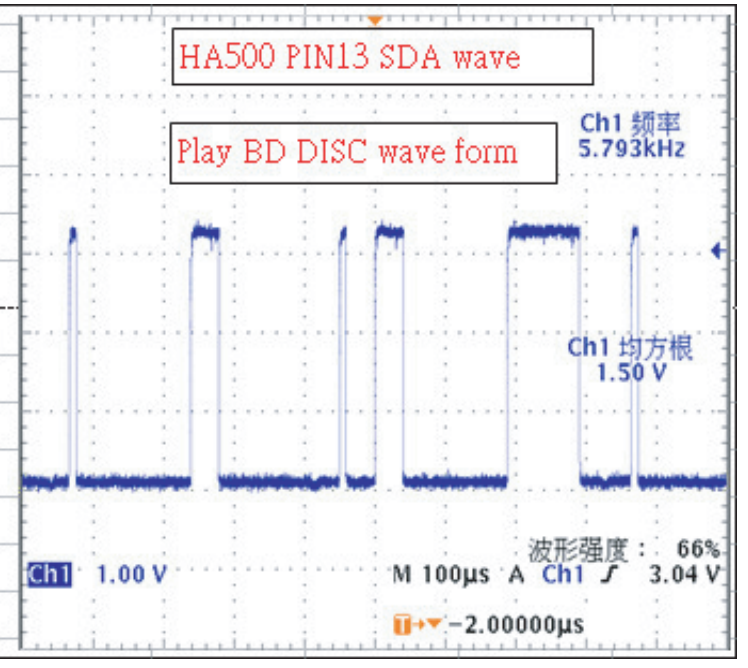
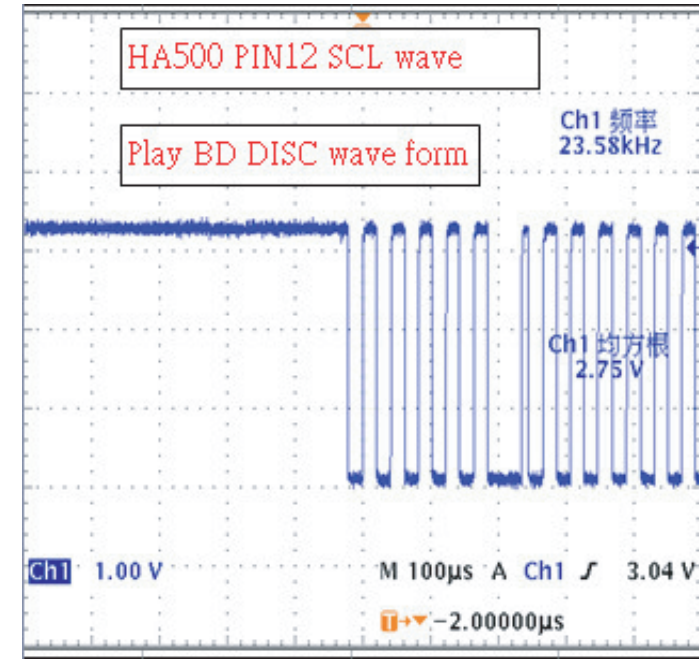
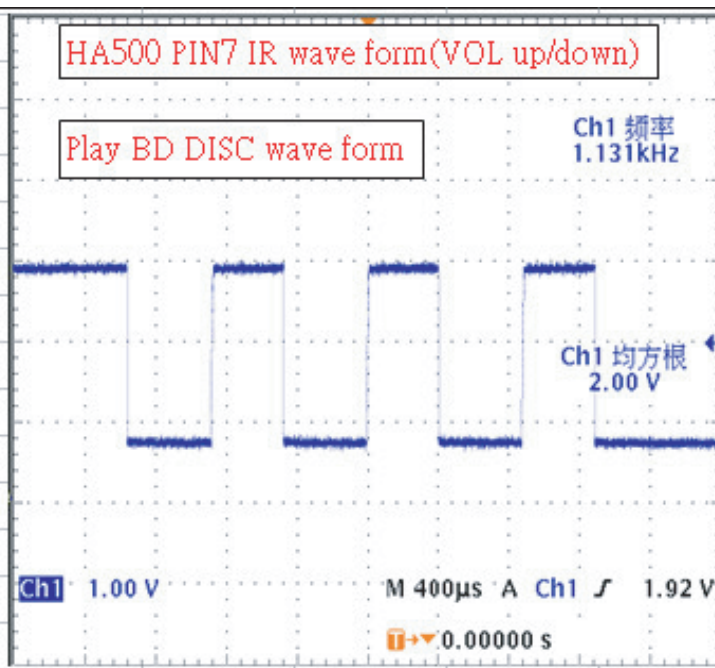
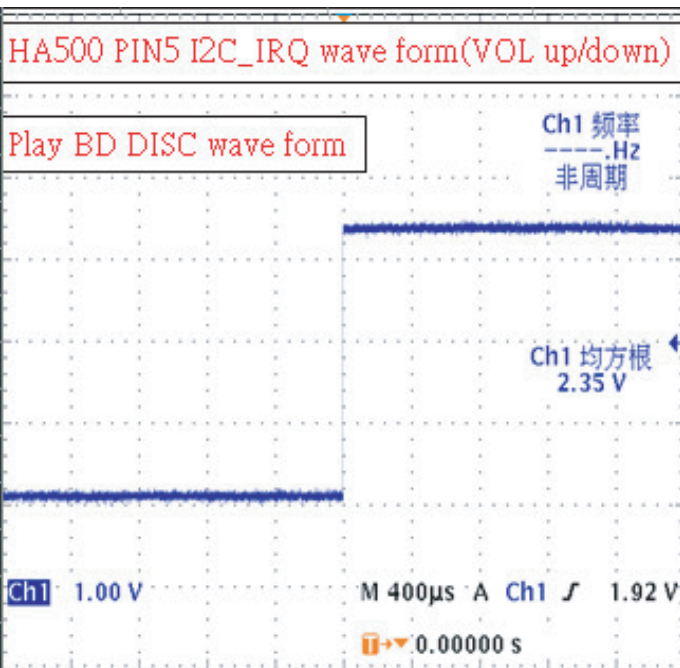
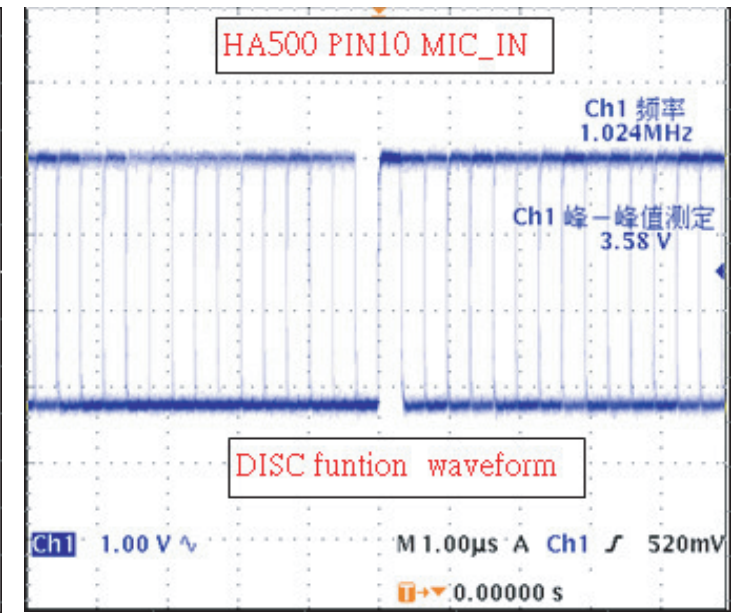
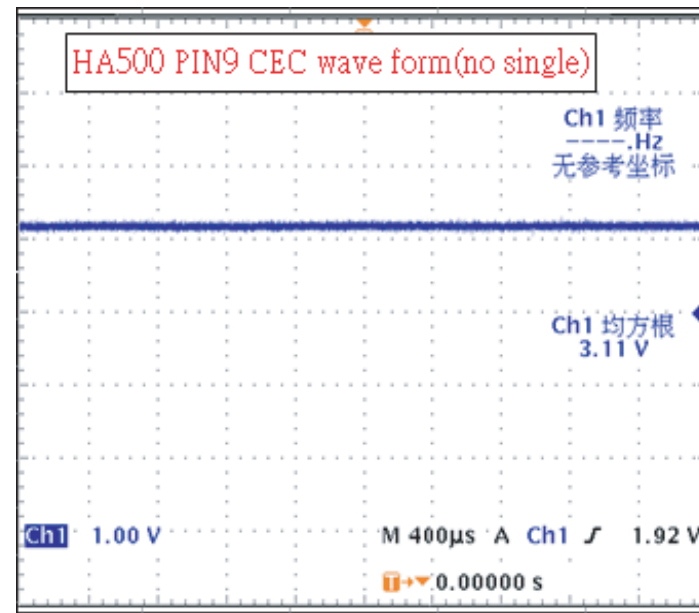
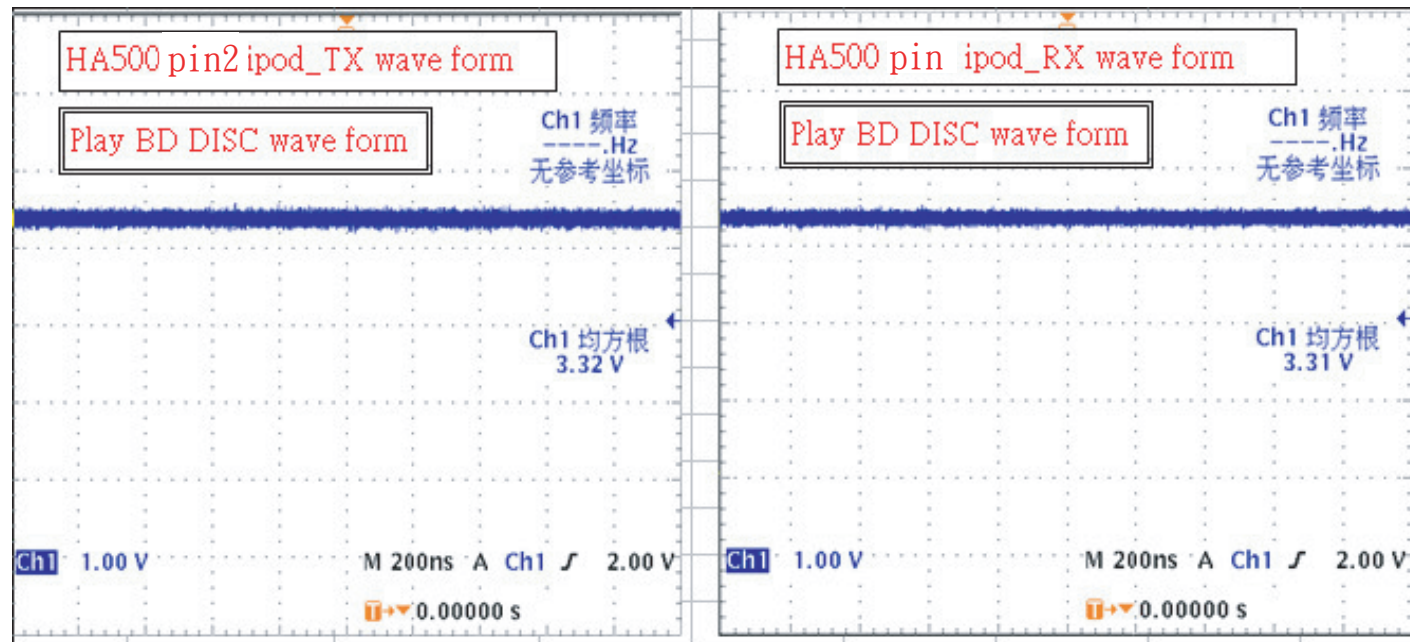

Waveforms for measure point

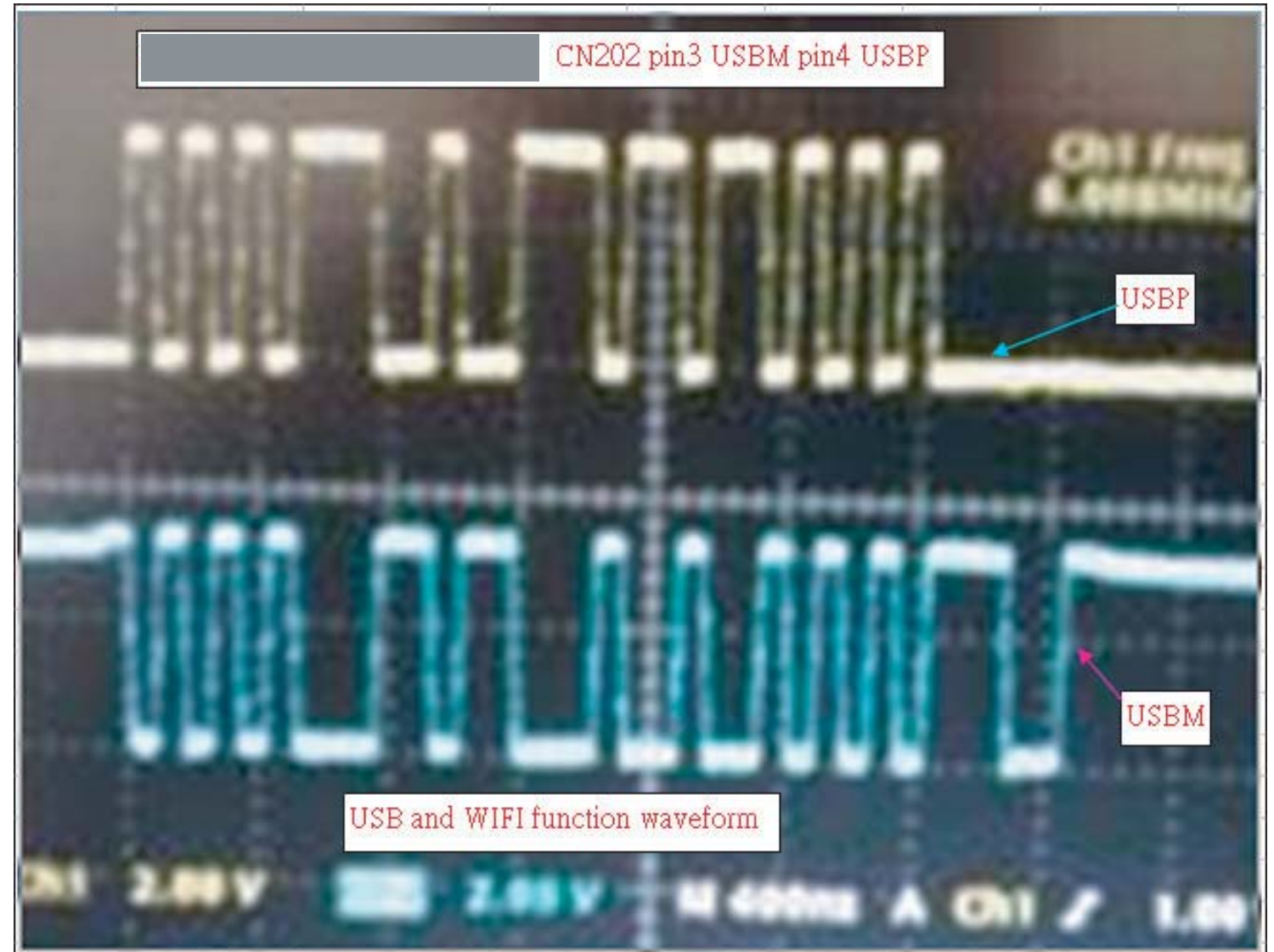
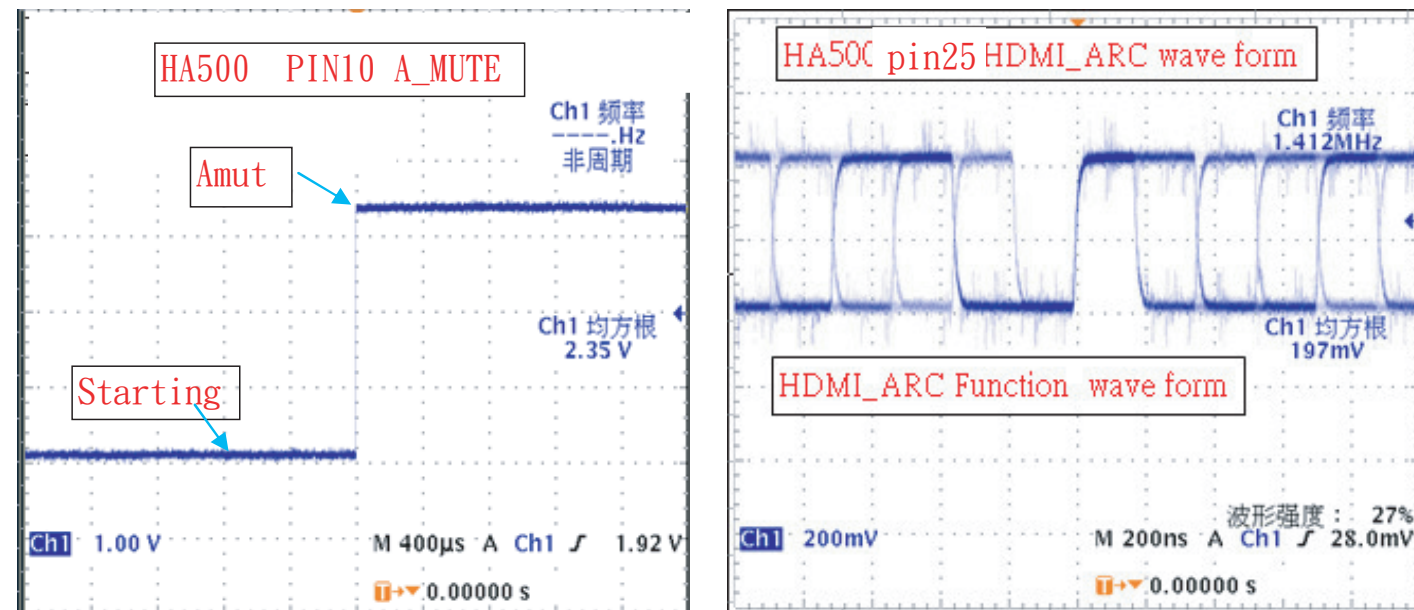
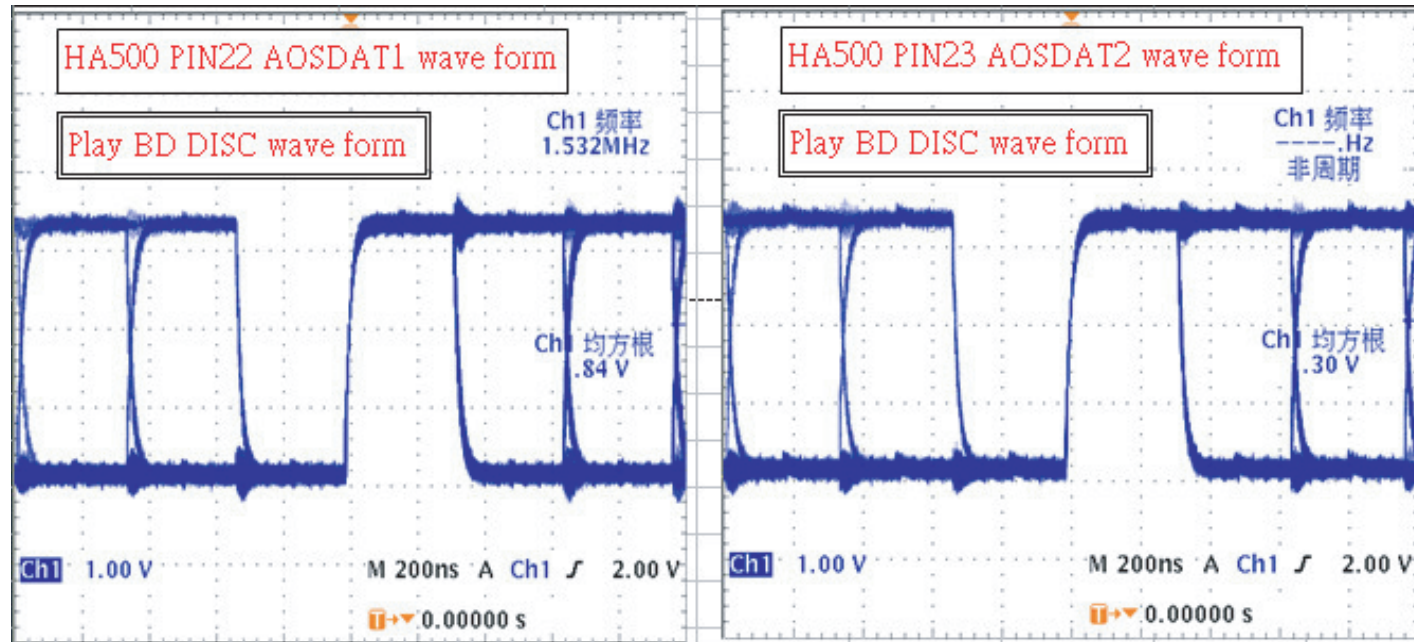
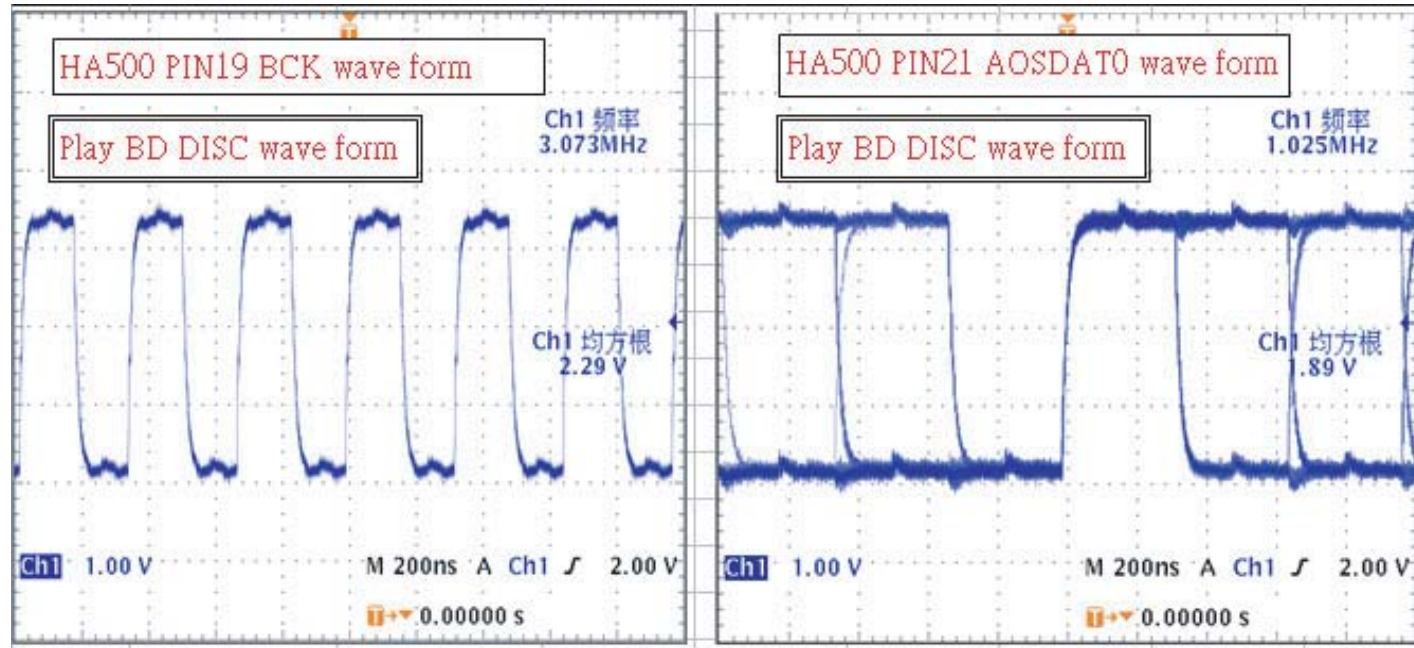

TOUCH BOARD

TABLE OF CONTENTS

Circuit Diagram.....	9-2
PCB Layout Top & Bottom View.....	9-3

CIRCUIT DIAGRAM

C1 A3 C2 A2 C4 A4 C6 B2 C9 B4 J1 A4 R10 B1 R12 B2 R14 B3 R16 B3 R2 A3 R4 A3 R6 A4 R8 B3
 C10 B4 C3 A2 C5 A4 C8 B3 D1 A3 R1 A3 R11 B1 R13 B2 R15 B3 R17 B3 R3 A4 R5 A4 R7 A3 U1 B2

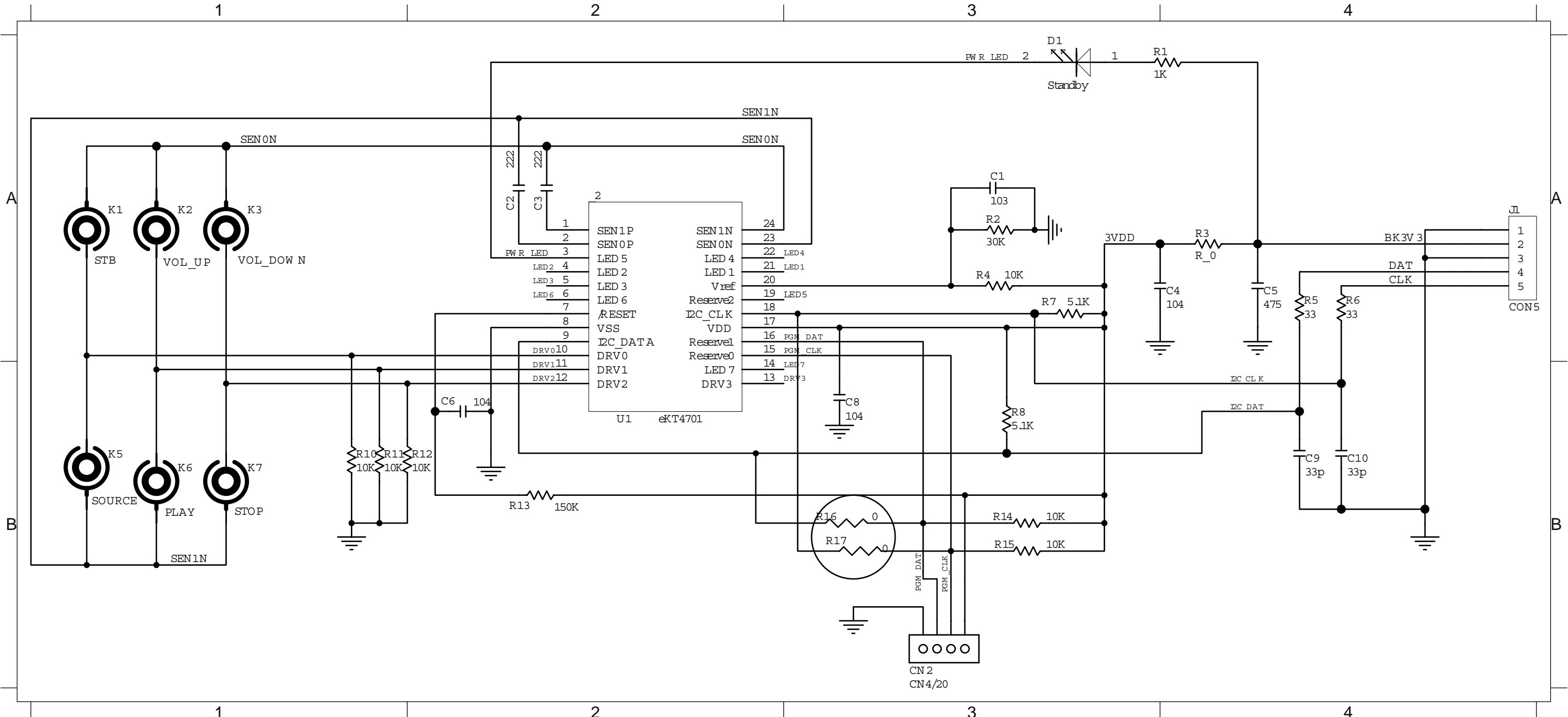

PCB LAYOUT - TOP VIEW

9-3

9-3

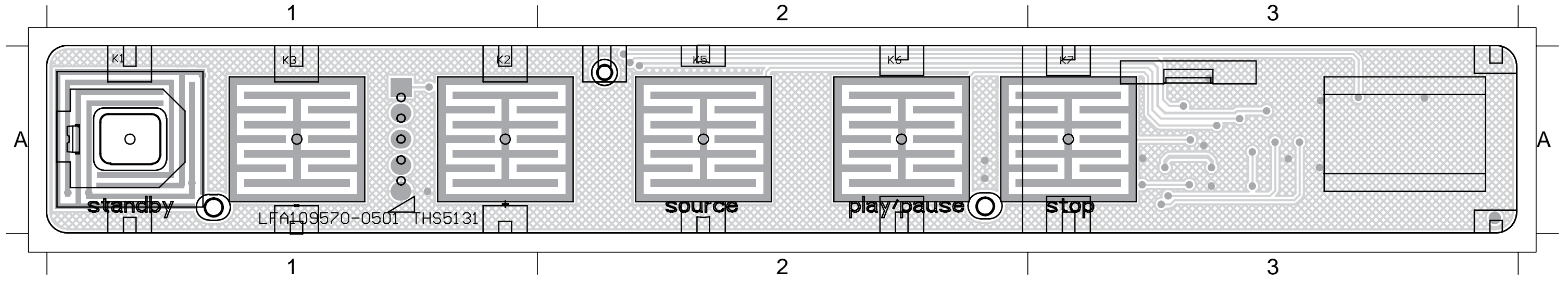

PCB LAYOUT - BOTTOM VIEW

- C1 A3 C2 A3 C4 A3 C6 A3 C9 A3 J1 A3 R10 A3 R12 A3 R14 A3 R16 A3 R2 A3 R4 A3 R6 A3 R8 A3
- C10 A3 C3 A3 C5 A3 C8 A3 D1 A1 R1 A3 R11 A3 R13 A3 R15 A3 R17 A3 R3 A3 R5 A3 R7 A3 U1 A3

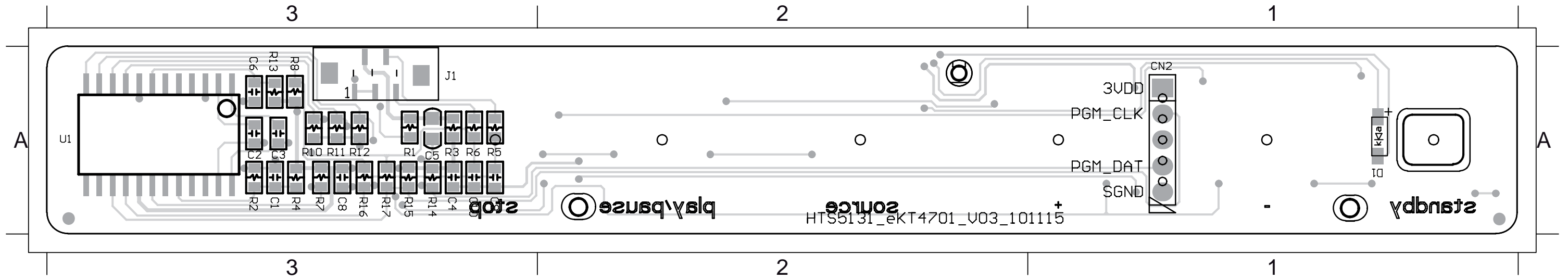

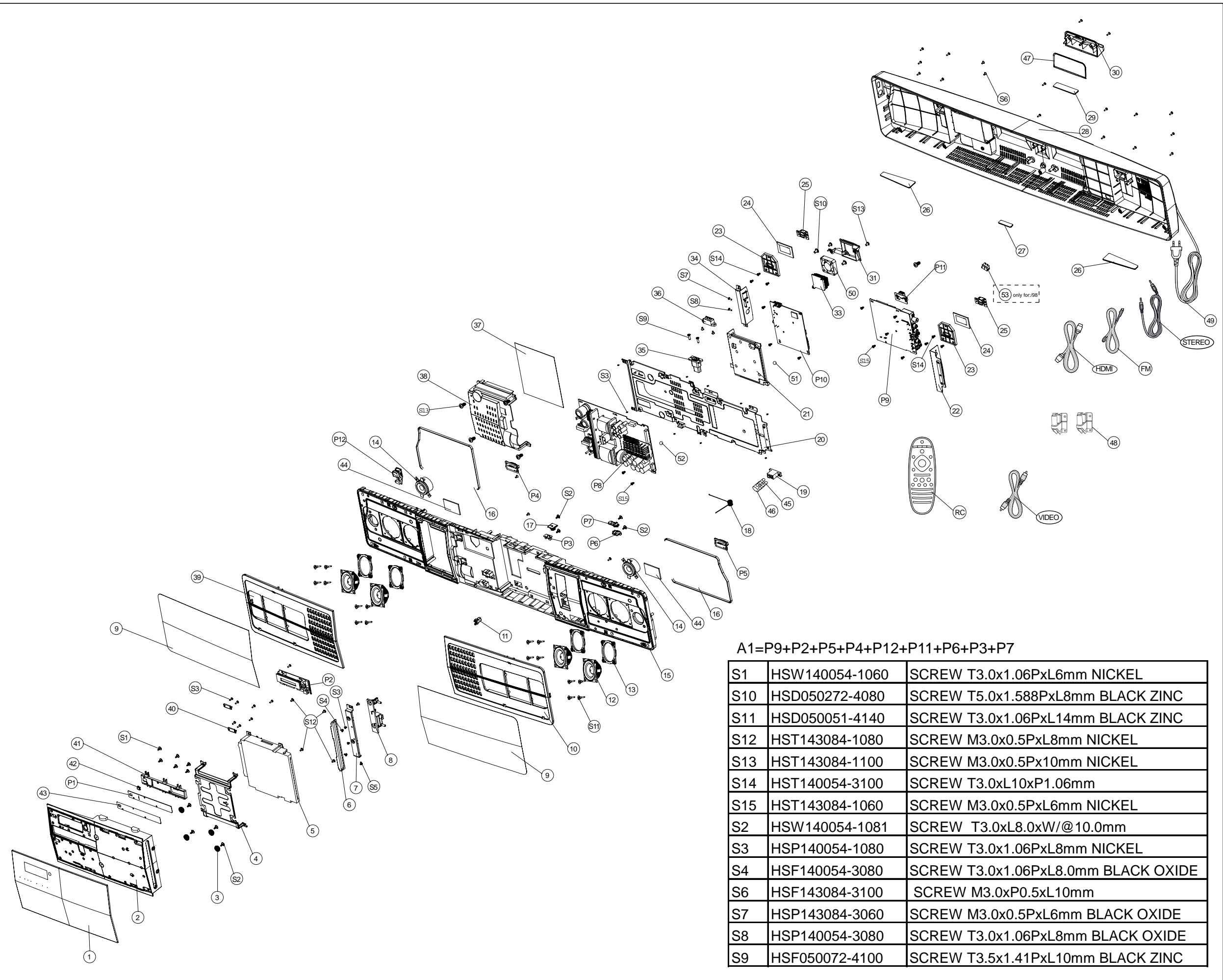

A1=P9+P2+P5+P4+P12+P11+P6+P3+P7

S1	HSW140054-1060	SCREW T3.0x1.06PxL6mm NICKEL
S10	HSD050272-4080	SCREW T5.0x1.588PxL8mm BLACK ZINC
S11	HSD050051-4140	SCREW T3.0x1.06PxL14mm BLACK ZINC
S12	HST143084-1080	SCREW M3.0x0.5PxL8mm NICKEL
S13	HST143084-1100	SCREW M3.0x0.5Px10mm NICKEL
S14	HST140054-3100	SCREW T3.0xL10xP1.06mm
S15	HST143084-1060	SCREW M3.0x0.5PxL6mm NICKEL
S2	HSW140054-1081	SCREW T3.0xL8.0xW/@10.0mm
S3	HSP140054-1080	SCREW T3.0x1.06PxL8mm NICKEL
S4	HSF140054-3080	SCREW T3.0x1.06PxL8.0mm BLACK OXIDE
S6	HSF143084-3100	SCREW M3.0xP0.5xL10mm
S7	HSP143084-3060	SCREW M3.0x0.5PxL6mm BLACK OXIDE
S8	HSP140054-3080	SCREW T3.0x1.06PxL8mm BLACK OXIDE
S9	HSF050072-4100	SCREW T3.5x1.41PxL10mm BLACK ZINC

REVISION LIST

Version 1.0

*Initial release

Version 1.1

*Updated to include /98 version.

Version 1.2

*Updated to include /51 version.