

Block Diagram

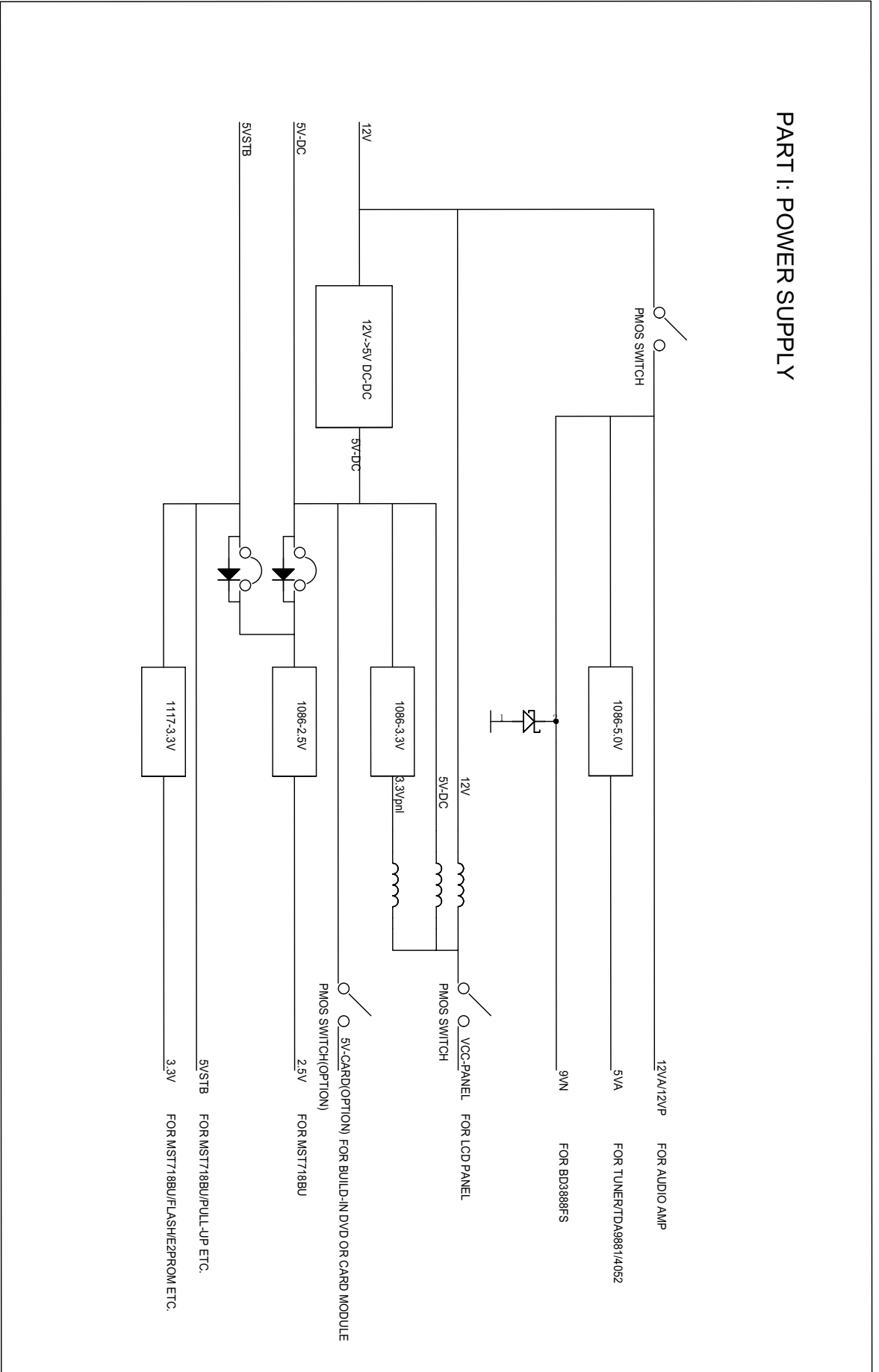

Block Diagram

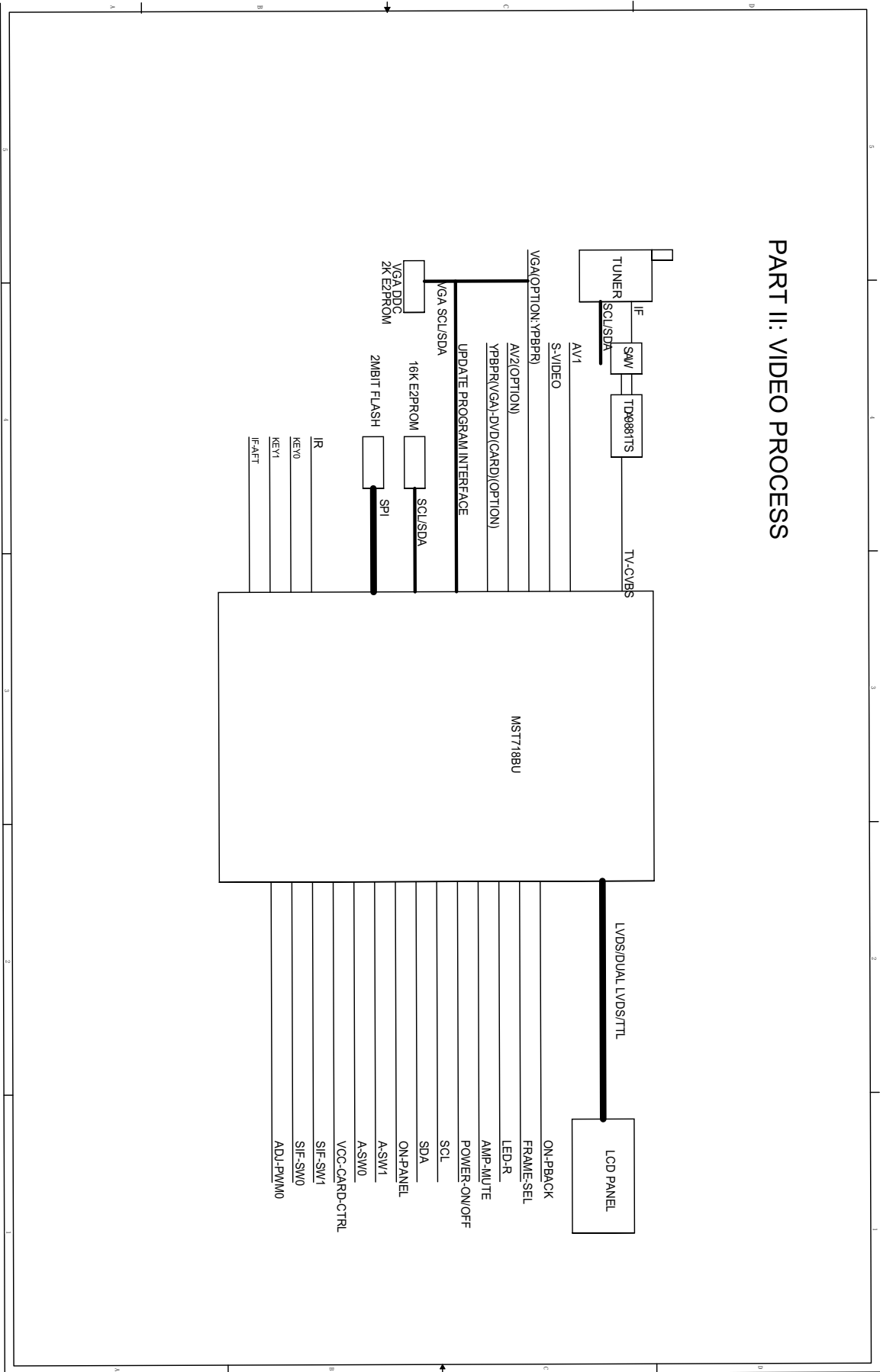

Block Diagram

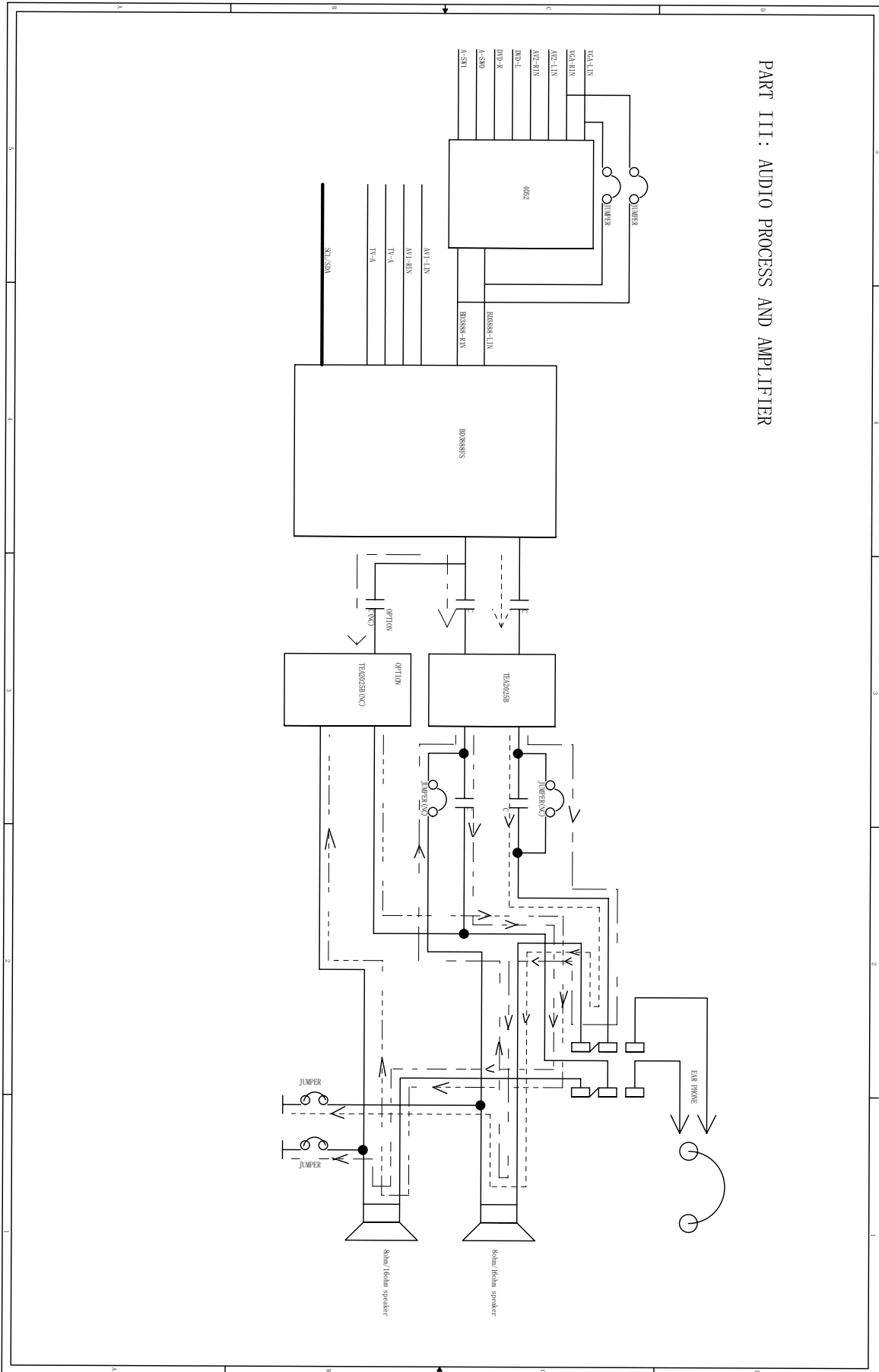

IC Block Diagram

U701(STEREO AUDIO AMPLIFIER)TEA2025B
BLOCK DIAGRAM

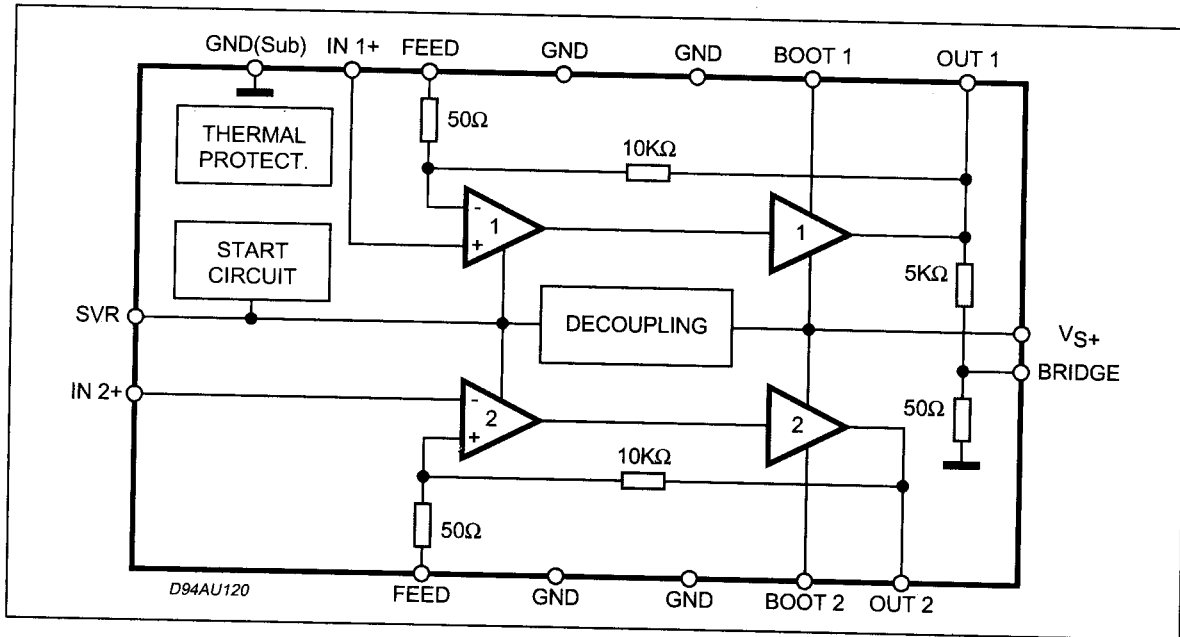

U402(2M BIT SERIAL FLASH MEMORY)EN25P20-100GCP

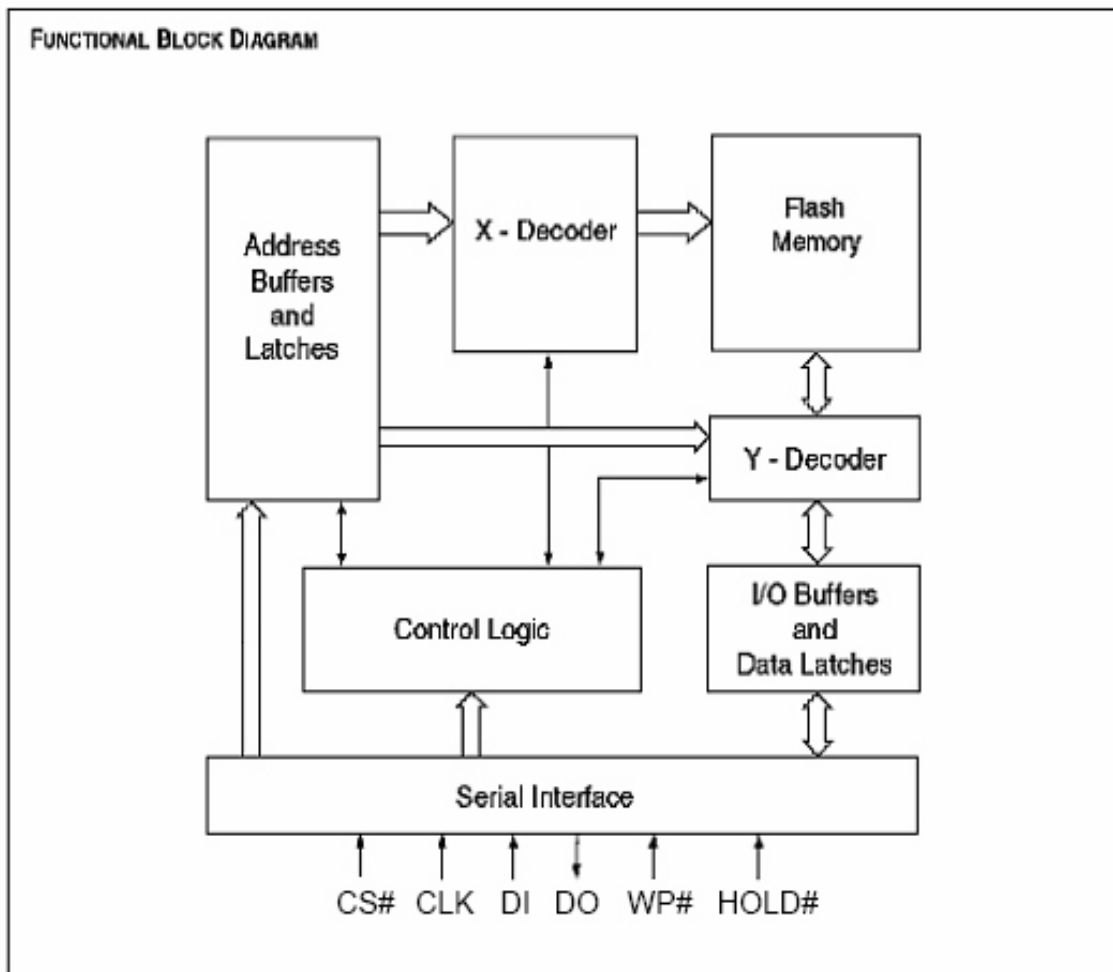

IC Block Diagram

U603(SYNCHRONOUS PWM CONTROLLER)IRU3037CS

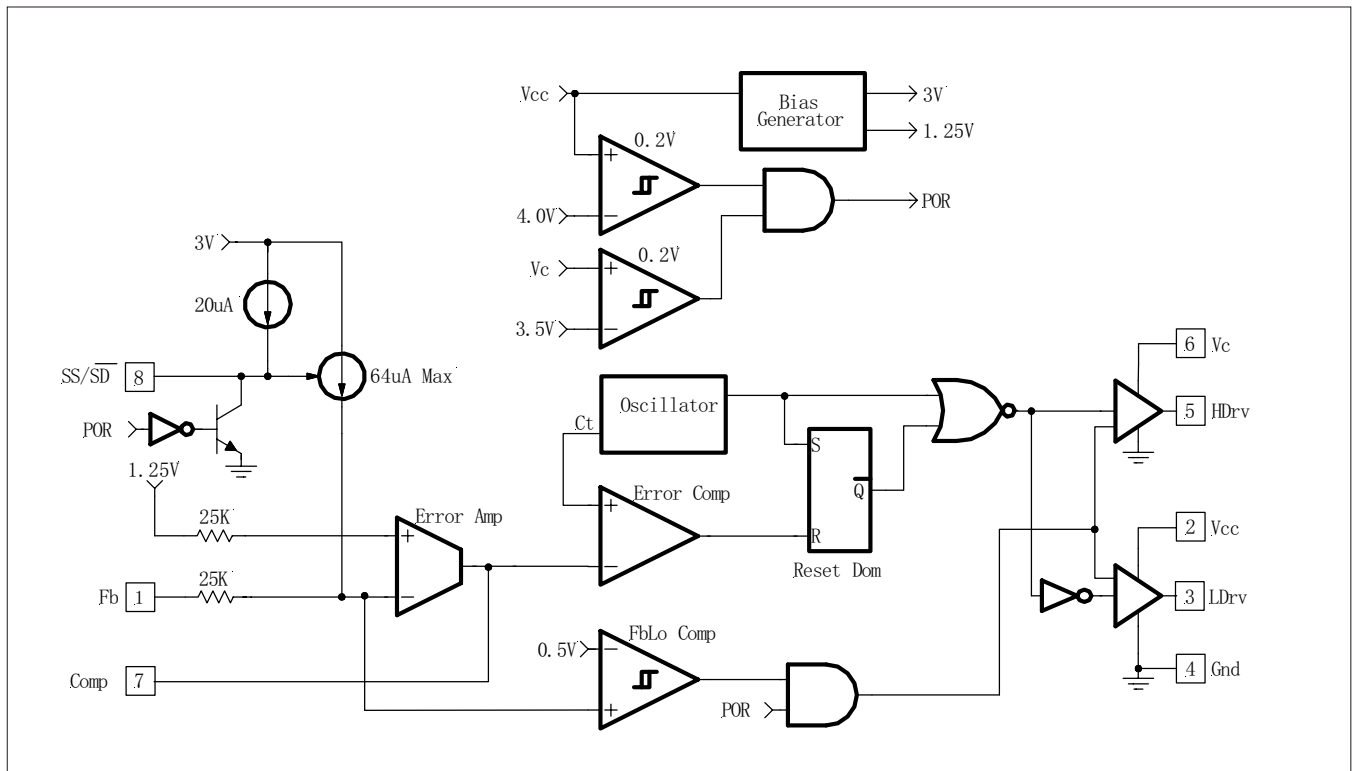

IC Block Diagram

U400(LCD TV PROCESSOR WITH VIDEO DECODER)MST718BU

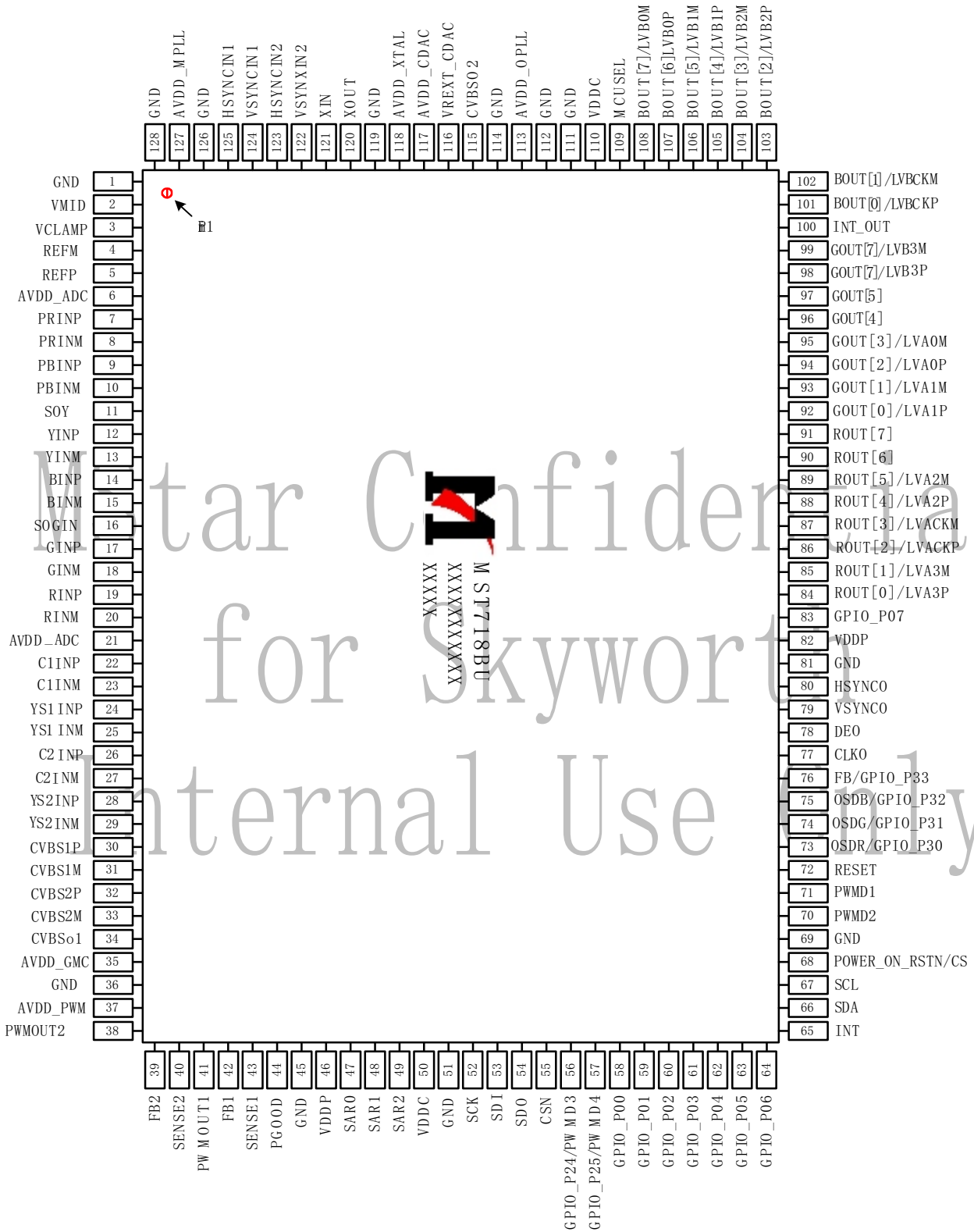

IC Block Diagram

U604(1A LOW DROPOUT VOLTAGE REGULATOR)

PIN DESCRIPTIONS

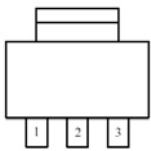
FIXED VERSION	ADJUSTABLE VERSION	SOT-223 Top View
1- Ground	1-Adjust	
2- V_{OUT}	2- V_{OUT}	
3- V_{IN}	3- V_{IN}	

U200(2K 2-WIRE SERIAL EEPROM) AT24C02AN-10SC

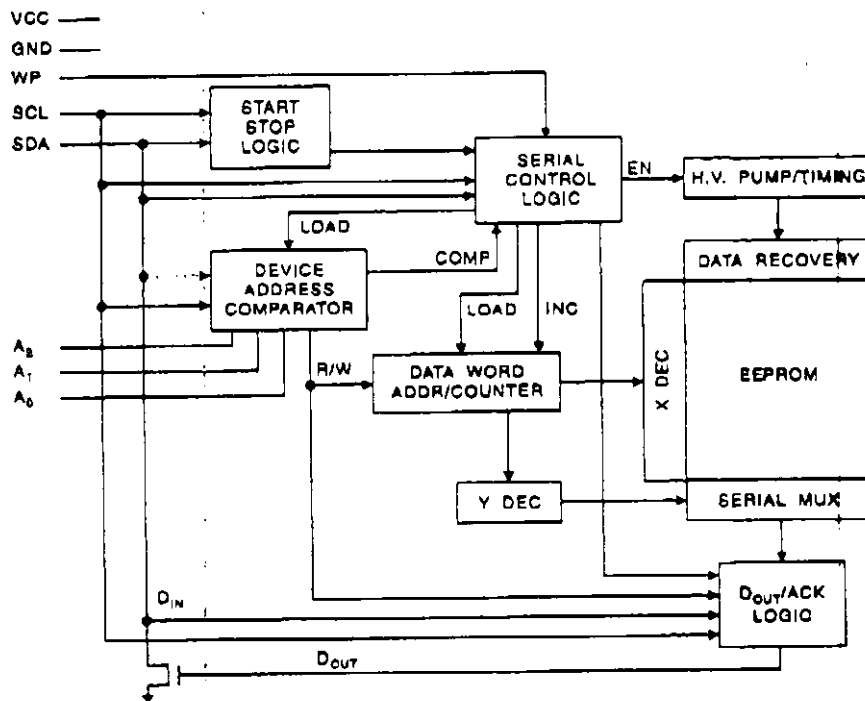

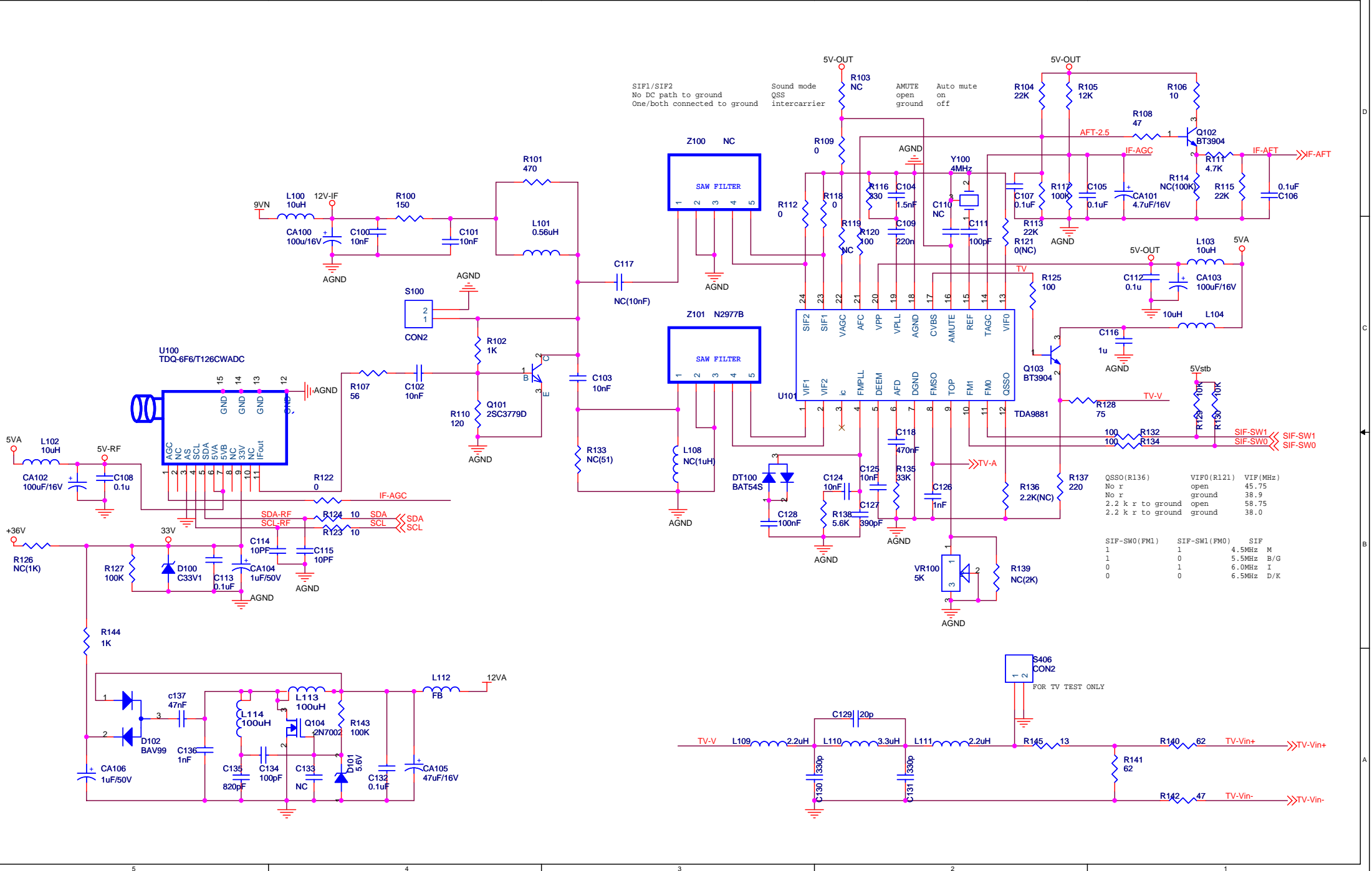

FOR TV TEST ONLY

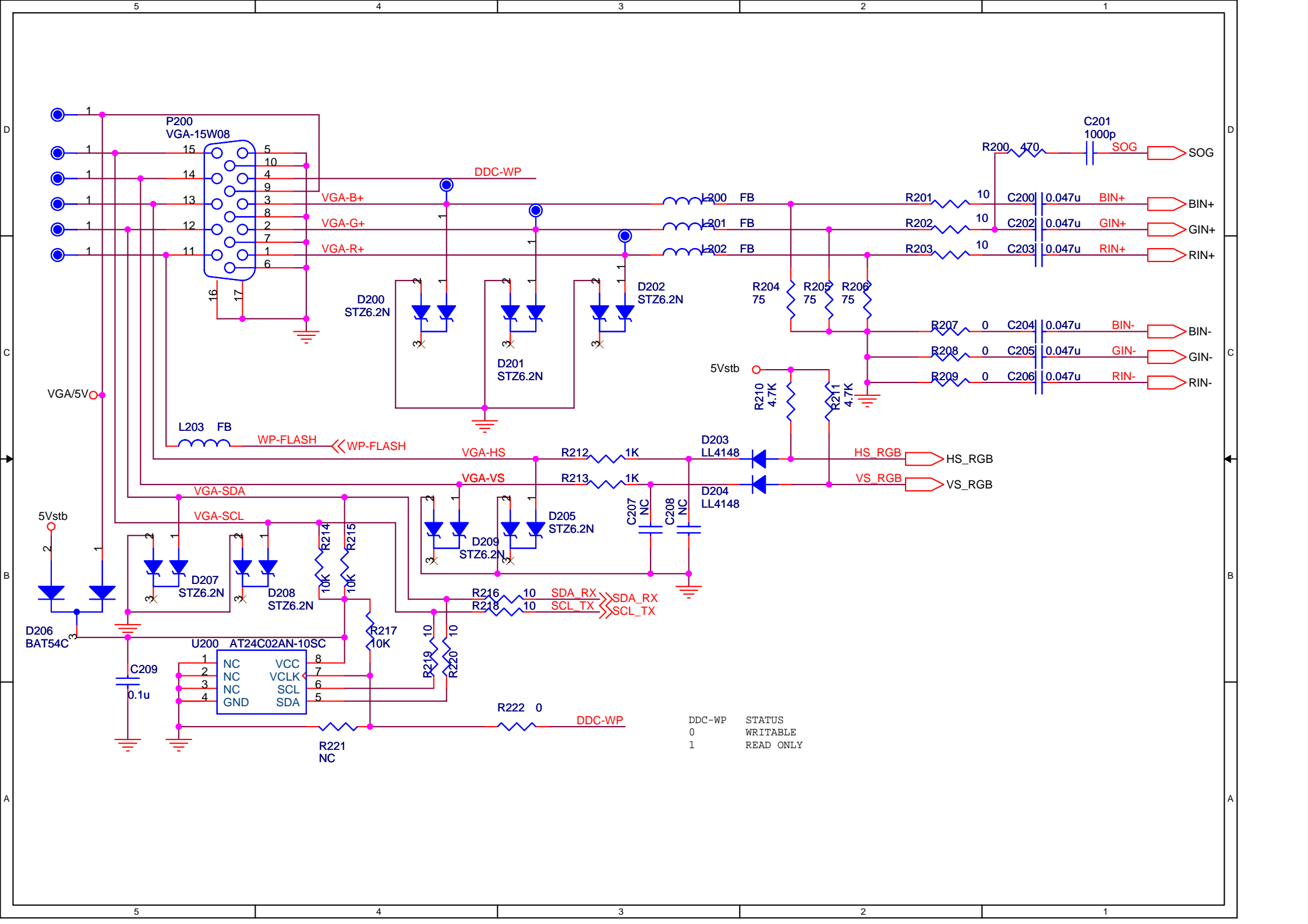

DDC-WP STATUS
 0 WRITABLE
 1 READ ONLY

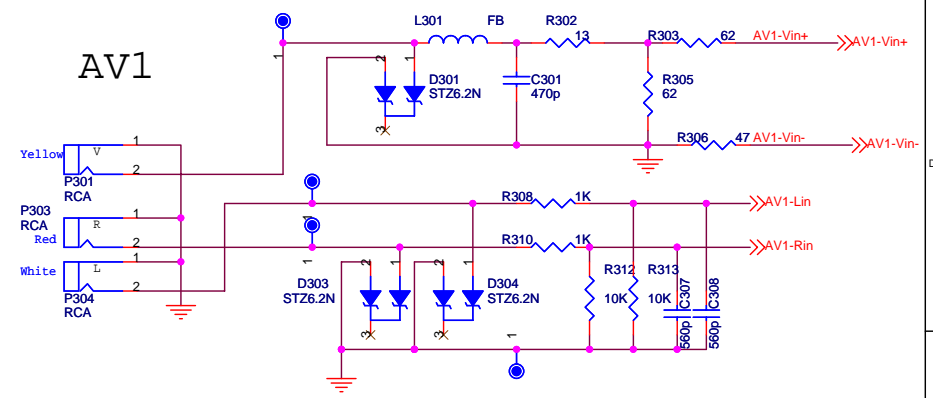
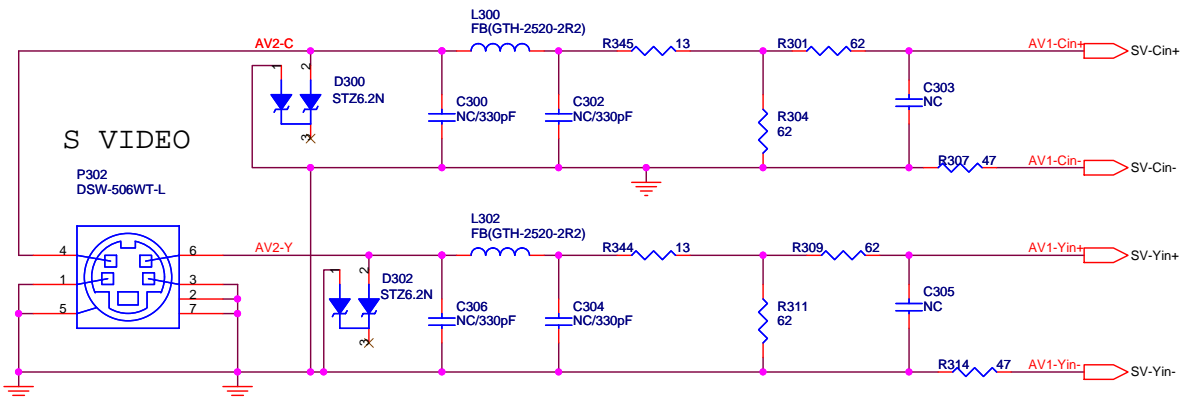

AV1/S-VIDEO AUDIO

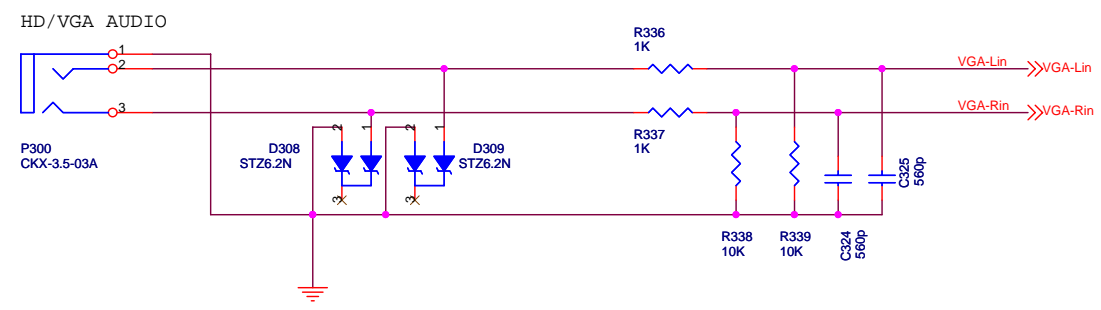
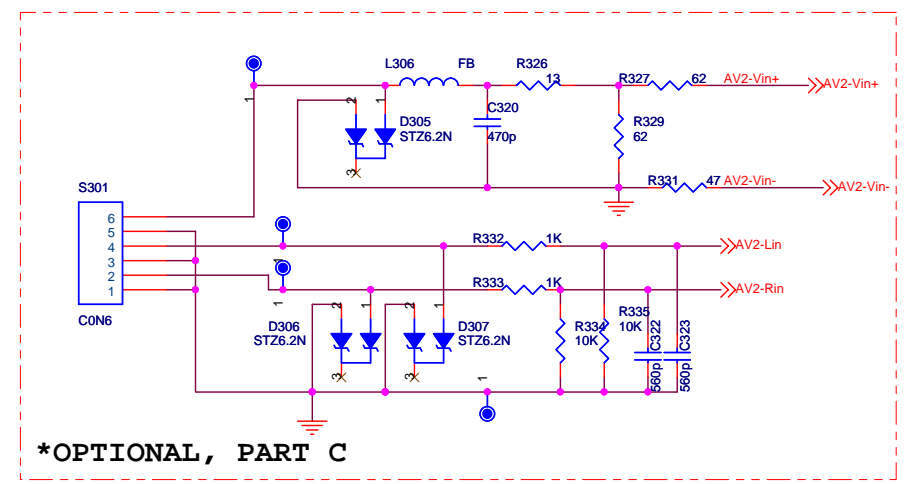
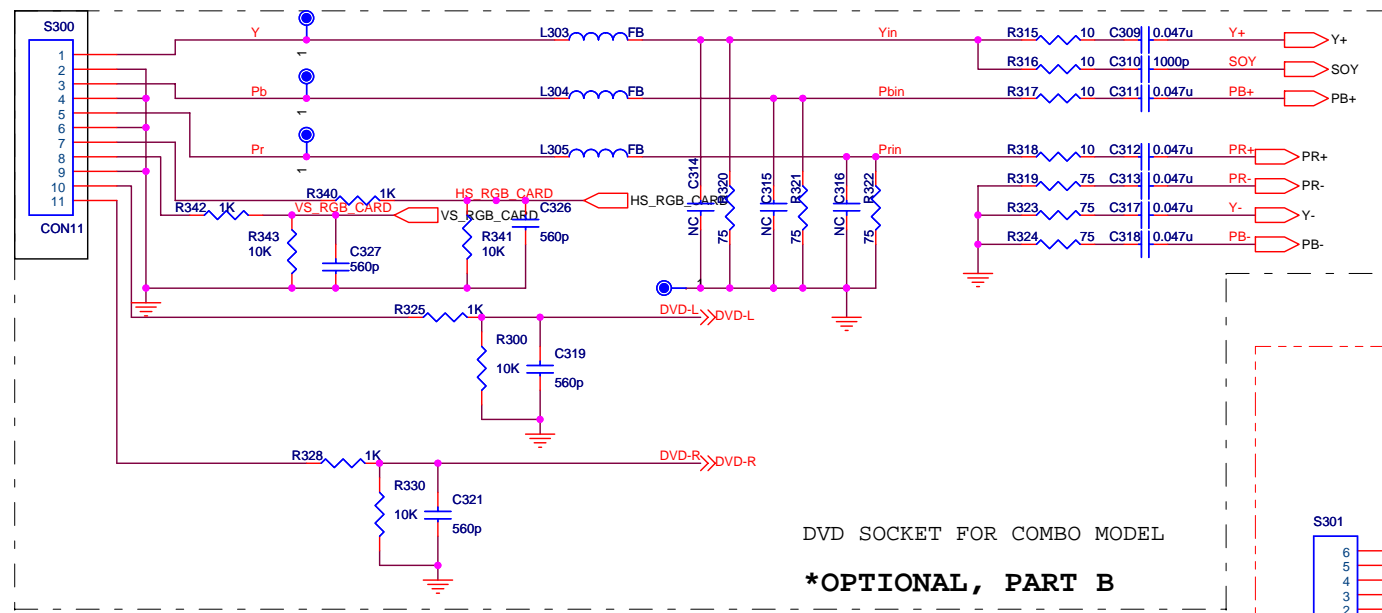

Debug port

MST718BU

Shield for MST718BU

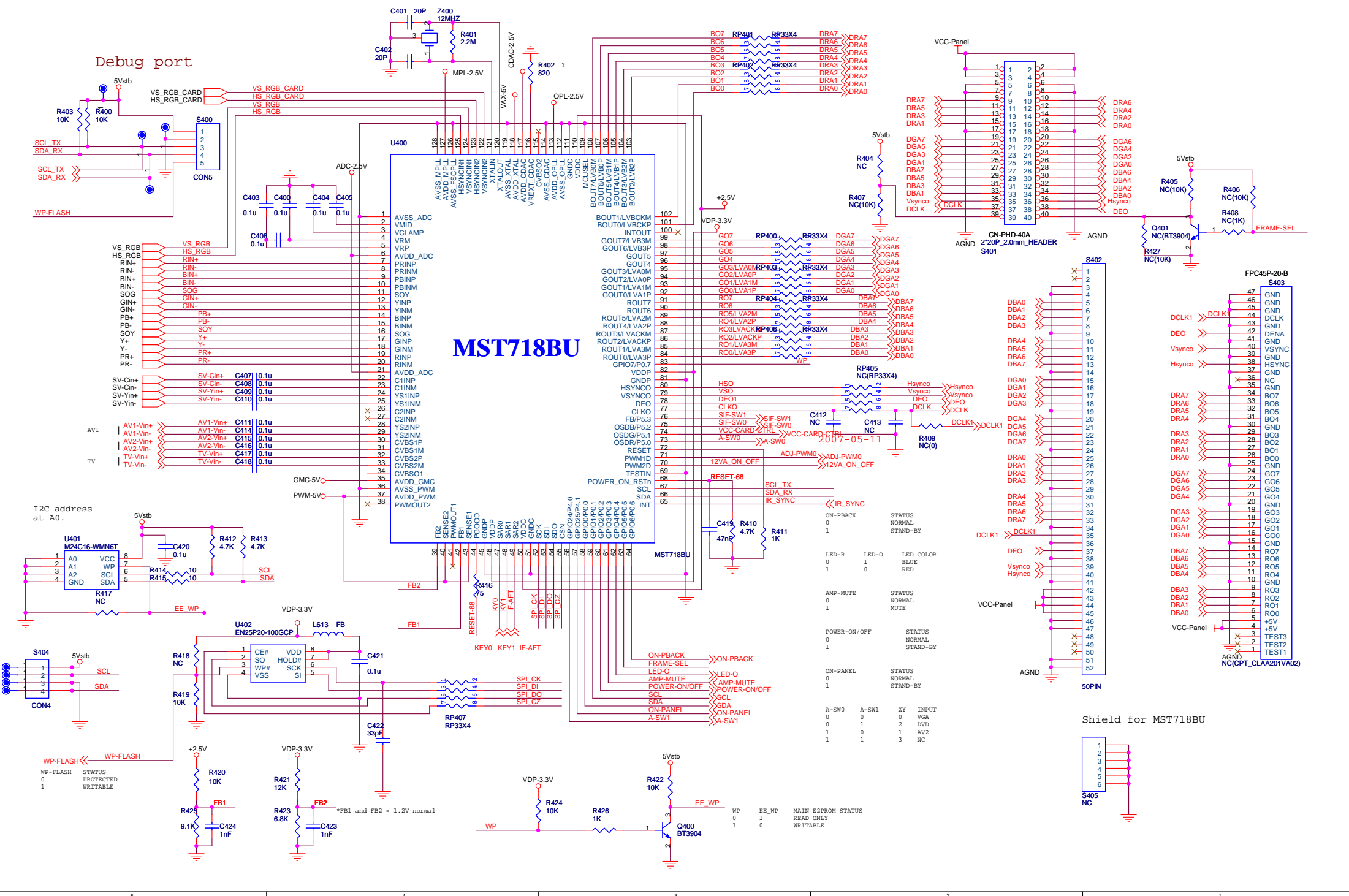

I2C address at A0.

WP-FLASH
0 PROTECTED
1 WRITABLE

WP EE_WP MAIN E2PROM STATUS
0 1 READ ONLY
1 0 WRITABLE



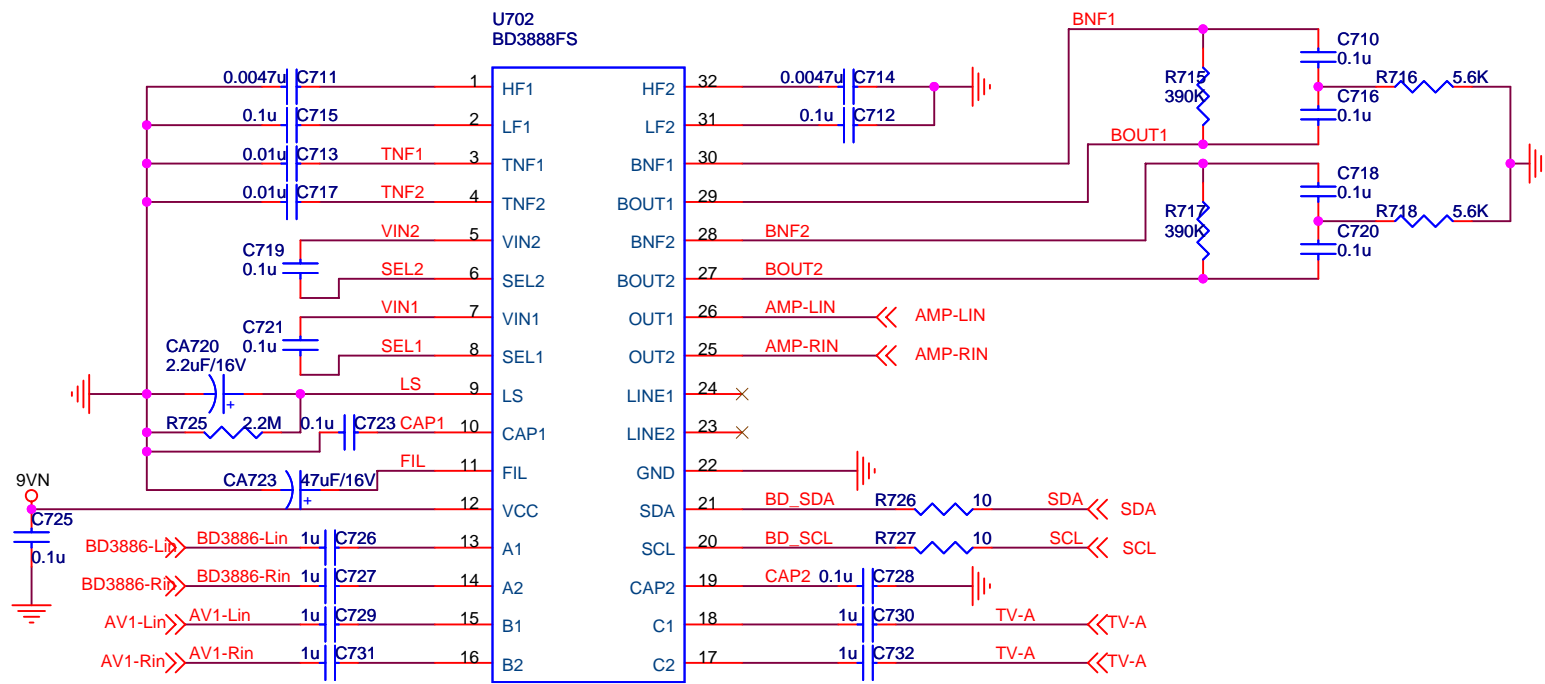
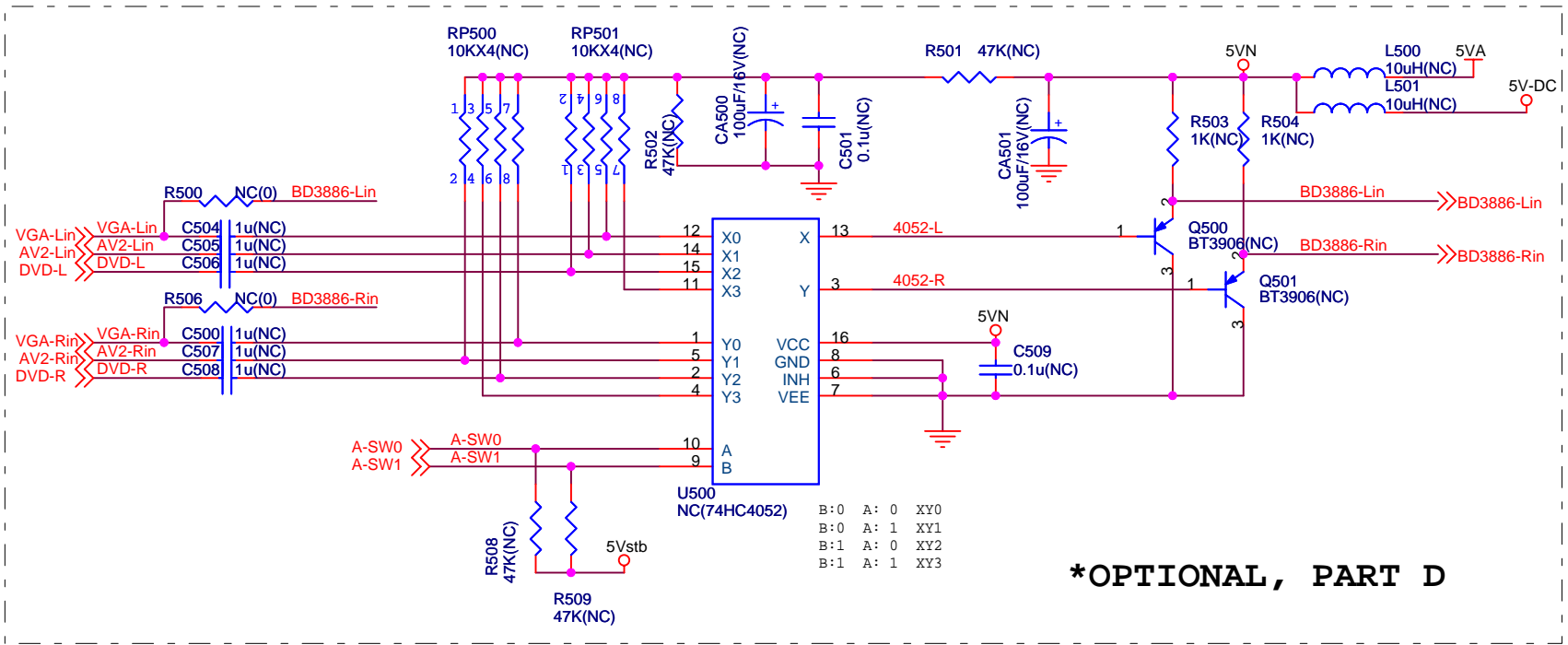

POWER ADAPTER PORT

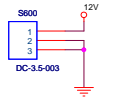

For audio amplifier

Power for 3.3V Panel
*OPTIONAL, PART E

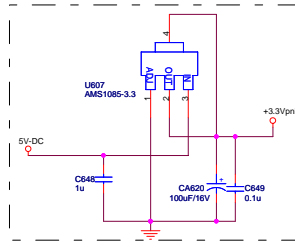

Power for Panel

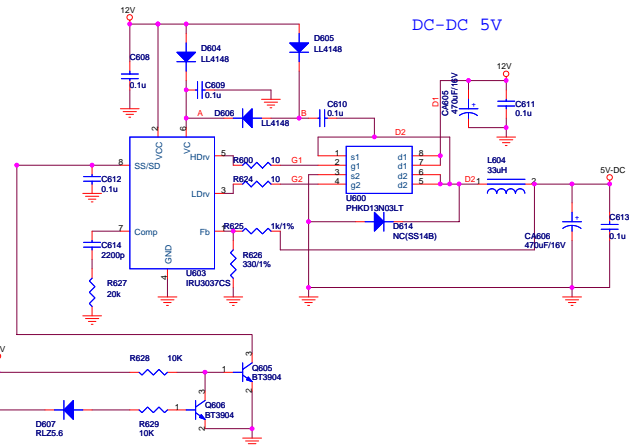
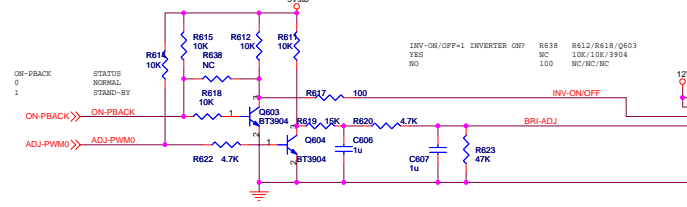
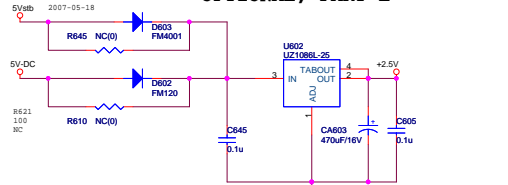
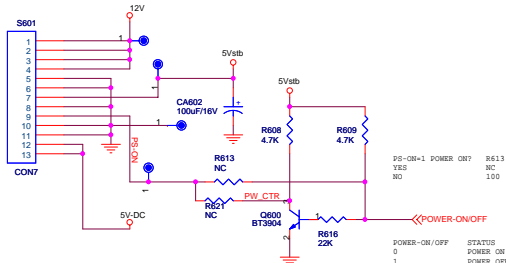
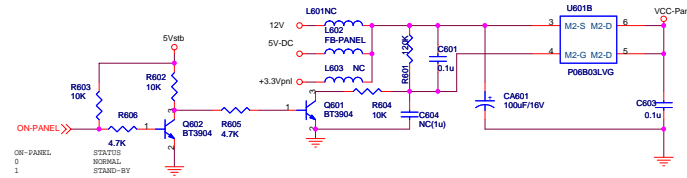

DC-DC 5V

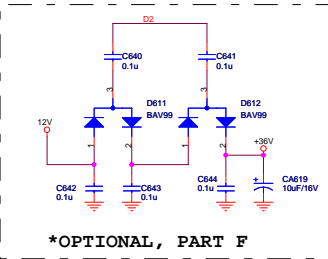

Power for MST718A

*OPTIONAL, PART F

9V for Audio processor

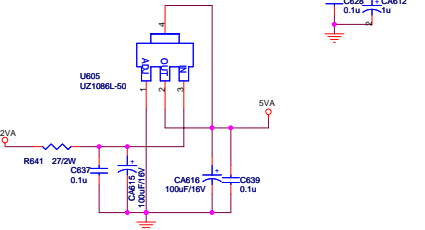
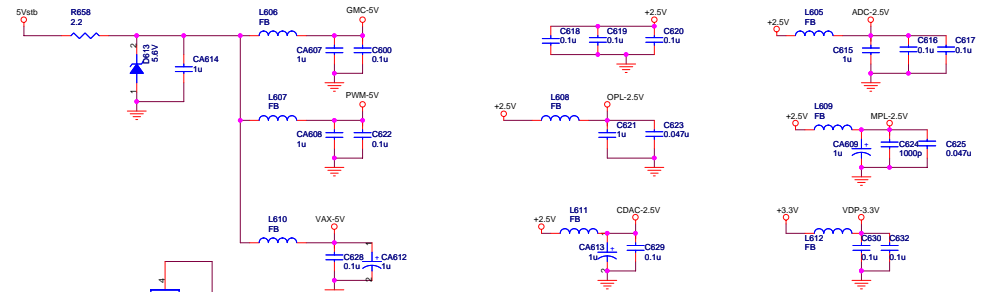
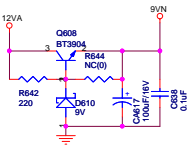

Power for DVD

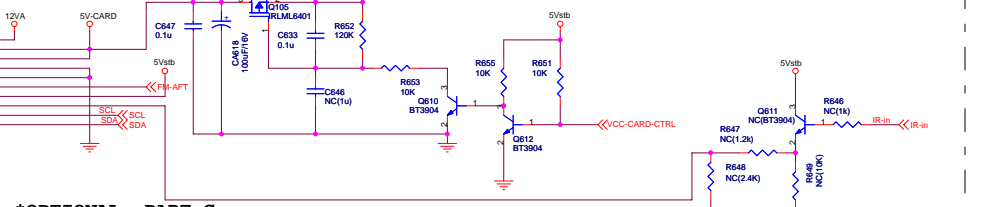

*OPTIONAL, PART G

3.3V for flash

