

Service Manual

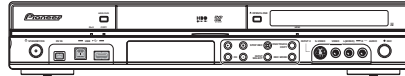

DVR-LX60

ORDER NO.
RRV3557

DVD RECORDER

DVR-LX60

DVR-550H-S

DVR-550H-AV

THIS MANUAL IS APPLICABLE TO THE FOLLOWING MODEL(S) AND TYPE(S).

Model	Type	Power Requirement	Region No.	Serial No. Please confirm 3rd & 4th alphabetical letters.
DVR-LX60	WYXV5	AC 220 V to 240 V	2	&&DL#####\$
DVR-LX60	YXVRE5	AC 220 V to 240 V	5	&&DL#####\$
DVR-550H-S	WYXV5	AC 220 V to 240 V	2	&&DL#####\$
DVR-550H-S	YXVRE5	AC 220 V to 240 V	5	&&DL#####\$
DVR-550H-AV	WYXV5	AC 220 V to 240 V	2	&&DL#####\$



For details, refer to "Important Check Points for good servicing".

SAFETY INFORMATION

■ LABEL CHECK

WARNING!

The laser component is capable of emitting radiation exceeding the limit for CLASS 1. A specially instructed person should do servicing operation of the apparatus.

Laser Pickup specifications and Laser characteristics

For CD

Wave length : 785nm

Operating output :

Read mode : 1.07mW (CW), Class1

Maximum output : Class1M

For DVD

Wave length : 660nm

Operating output :

Read mode : 1.08mW, Class1

Write mode : 21.89mW (Pulse), Class1M

Maximum output : Class2M

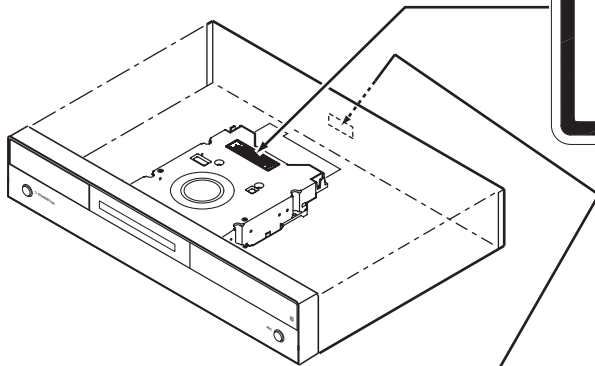

CAUTION CLASS 3B VISIBLE AND INVISIBLE LASER RADIATION WHEN OPEN, AVOID EXPOSURE TO THE BEAM. VRW2282 - A
ATTENTION RADIATIONS LASER VISIBLES ET INVISIBLES DE CLASSE 3B QUAND OUVERT. ÉVITEZ TOUTE EXPOSITION AU FAISCEAU.
ADVARSEL KLASSE 3B SYNLIG OG USYNLIG LASERSTRÅLING VED ÅBNING. UNDGÅ UDSÆTTELSE FOR STRÅLING.
VARNING KLASS 3B SYNLIG OCH OSYNLIG LASERSTRÅLNING NÄR DENNA DEL ÄR ÖPPNAD. UNDVIK ATT UTSÄTTA DIG FÖR STRÅLEN.
VORSICHT BEI GEÖFFNETER ABDECKUNG IST SICHTBARE UND UNSICHTBARE LASERSTRAHLUNG DER KLASSE 3B IM GERÄTENINNEN VORHANDEN.
NICHT DEM LASERSTRAHLE AUSSETZEN!
PRECAUCIÓN CUANDO SE ABRE HAY RADIACIÓN LÁSER DE CLASE 3B VISIBLE E INVISIBLE. EVITE LA EXPOSICIÓN A LOS RAYOS LÁSER.
VARO! AVATTASSA OLET ALTUUNA NÄKYMÄLLI JA NÄKYMÄTTÖMÄLLI LUKKAN 3B LASERSTRÄLLE. ÄLÄ KATSO SÄRTESEEN.
注意 打開時會有CLASS 3B可視和不可見雷射輻射・請勿近距離察視・
注意 ここを開くとCLASS 3Bの可視レーザー光及び不可視レーザー光が出ます。ビームを直接見たり、触れたりしないこと。

VRW2262

Additional Laser Caution

1. The ON/OFF(ON:low level,OFF:high level) status of the CLAMP signals for detecting the loading state are detected by the drive CPUs, and the design prevents laser diode oscillation when the CLAMP signal turns OFF. In normal operation, if no disc is clamped, the laser diode oscillation is disabled. However, the interlock does not always operate in the test mode.
2. When the cover is opened, close viewing of the objective lens with the naked eye will cause exposure to a Class 3A laser beam.

[Important Check Points for Good Servicing]

In this manual, procedures that must be performed during repairs are marked with the below symbol. Please be sure to confirm and follow these procedures.

1. Product safety



Please conform to product regulations (such as safety and radiation regulations), and maintain a safe servicing environment by following the safety instructions described in this manual.

- ① Use specified parts for repair.

Use genuine parts. Be sure to use important parts for safety.

- ② Do not perform modifications without proper instructions.

Please follow the specified safety methods when modification (addition/change of parts) is required due to interferences such as radio/TV interference and foreign noise.

- ③ Make sure the soldering of repaired locations is properly performed.

When you solder while repairing, please be sure that there are no cold solder and other debris. Soldering should be finished with the proper quantity. (Refer to the example)

- ④ Make sure the screws are tightly fastened.

Please be sure that all screws are fastened, and that there are no loose screws.

- ⑤ Make sure each connectors are correctly inserted.

Please be sure that all connectors are inserted, and that there are no imperfect insertion.

- ⑥ Make sure the wiring cables are set to their original state.

Please replace the wiring and cables to the original state after repairs. In addition, be sure that there are no pinched wires, etc.

- ⑦ Make sure screws and soldering scraps do not remain inside the product.

Please check that neither solder debris nor screws remain inside the product.

- ⑧ There should be no semi-broken wires, scratches, melting, etc. on the coating of the power cord.

Damaged power cords may lead to fire accidents, so please be sure that there are no damages. If you find a damaged power cord, please exchange it with a suitable one.

- ⑨ There should be no spark traces or similar marks on the power plug.

When spark traces or similar marks are found on the power supply plug, please check the connection and advise on secure connections and suitable usage. Please exchange the power cord if necessary.

- ⑩ Safe environment should be secured during servicing.

When you perform repairs, please pay attention to static electricity, furniture, household articles, etc. in order to prevent injuries. Please pay attention to your surroundings and repair safely.

2. Adjustments



To keep the original performance of the products, optimum adjustments and confirmation of characteristics within specification. Adjustments should be performed in accordance with the procedures/instructions described in this manual.

3. Lubricants, Glues, and Replacement parts



Use grease and adhesives that are equal to the specified substance. Make sure the proper amount is applied.

4. Cleaning



For parts that require cleaning, such as optical pickups, tape deck heads, lenses and mirrors used in projection monitors, proper cleaning should be performed to restore their performances.

5. Shipping mode and Shipping screws



To protect products from damages or failures during transit, the shipping mode should be set or the shipping screws should be installed before shipment. Please be sure to follow this method especially if it is specified in this manual.

CONTENTS

	SAFETY INFORMATION.....	2
	1. SERVICE PRECAUTIONS.....	6
A	1.1 NOTES ON SOLDERING.....	6
	1.2 NOTES ON HANDLING THE HDD.....	7
	1.3 NOTES ON REPLACEMENT OF THE SDRAM.....	9
	1.4 NOTE ON INSULATORS AND THEIR SET SCREWS.....	9
	2. SPECIFICATIONS.....	10
	2.1 ACCESSORIES.....	10
	2.2 SPECIFICATIONS.....	11
	2.3 DISC/CONTENT FORMAT.....	13
	2.4 PANEL FACILITIES.....	17
	3. BASIC ITEMS FOR SERVICE.....	22
	3.1 CHECK POINTS AFTER SERVICING.....	22
	3.2 QUICK REFERENCE.....	23
B	3.3 PCB LOCATIONS.....	24
	3.4 JIGS LIST.....	25
	4. BLOCK DIAGRAM.....	26
	4.1 OVERALL WIRING DIAGRAM.....	26
	4.2 OVERALL BLOCK DIAGRAM.....	28
	4.3 DETECTION AND ENCODE SYSTEM BLOCK DIAGRAM.....	30
	4.4 POWER BLOCK DIAGRAM.....	31
	5. DIAGNOSIS.....	32
	5.1 SETUP SEQUENCE.....	32
	5.2 DIAGNOSIS OF THE MAIN ASSY.....	33
	6. SERVICE MODE.....	37
	6.1 VERSION INFORMATION, ETC. (FIRST SCREEN).....	39
C	6.2 ATA/ATAPI DEBUG SCREEN (SECOND SCREEN).....	44
	6.3 VR-RECORDING-RELATED ERROR LOGS (FOURTH SCREEN).....	46
	6.4 VR-PLAYBACK-RELATED ERROR LOGS (FIFTH SCREEN).....	50
	6.5 DV SERVICE MODE.....	53
	6.6 EPG SERVICE MODE.....	56
	6.7 HDMI SERVICE MODE.....	58
	6.8 AGING MODE.....	60
	6.9 USB CHECK MODE.....	62
	6.10 HDD CHECK MODE.....	63
	7. DISASSEMBLY.....	69
	8. EACH SETTING AND ADJUSTMENT.....	74
	8.1 MODEL SETTING.....	74
D	8.2 LD POWER ADJUSTMENT.....	75
	8.3 CPRM ID NUMBER AND DATA SETTING.....	79
	8.4 FIRMWARE UPDATE METHOD.....	83
	8.5 VIDEO ADJUSTMENT FOR SPECIFIC AREA.....	86
	9. EXPLODED VIEWS AND PARTS LIST.....	90
	9.1 PACKING.....	90
	9.2 EXTERIOR SECTION.....	92
	9.3 FRONT PANEL SECTION.....	94
	9.4 SERVICE LOADER MAIN SECTION.....	98
	10. SCHEMATIC DIAGRAM.....	100
	10.1 SERVICE TUSB ASSY (1/4).....	100
E	10.2 SERVICE TUSB ASSY (2/4).....	102
	10.3 SERVICE TUSB ASSY (3/4).....	104
	10.4 SERVICE TUSB ASSY (4/4).....	106
	10.5 SERVICE FLKY ASSY.....	108
	10.6 SERVICE MAIN ASSY (1/5).....	110
	10.7 SERVICE MAIN ASSY (2/5).....	112
	10.8 SERVICE MAIN ASSY (3/5).....	114
	10.9 SERVICE MAIN ASSY (4/5).....	116
	10.10 SERVICE MAIN ASSY (5/5).....	118
	10.11 VDEC ASSY.....	120
	10.12 SERVICE DVUB ASSY.....	122
	10.13 POWER SUPPLY ASSY.....	124
F	10.14 WAVE FORMS.....	126
	11. PCB CONNECTION DIAGRAM.....	131
	11.1 SERVICE TUSB ASSY.....	132
	11.2 SERVICE FLKY ASSY.....	136

5	6	7	8
11.3 SERVICE FRJB ASSY.....			138
11.4 SERVICE MAIN ASSY.....			140
11.5 VDEC ASSY.....			144
11.6 SERVICE DVUB ASSY.....			148
11.7 POWER SUPPLY ASSY.....			150
12. PCB PARTS LIST.....			152
13. IC INFORMATION.....			179

A
B
C
D
E
F

1. SERVICE PRECAUTIONS

•When servicing this model, some service procedures may reset the customer settings to the factory default settings. Make sure to explain this to the customer.

•An HDD (Hard Disc Drive) is mounted in this product.

When an HDD becomes defective and inoperable, restoration of the user's data recorded on the HDD, or copying of the user's recorded data to other media (such as a new HDD) is totally impossible.

Before servicing, OBTAIN THE USER'S PRIOR CONSENT to that effect.

The user must be made aware that all recorded data are deleted if the HDD is initialized.

1.1 NOTES ON SOLDERING

• For environmental protection, lead-free solder is used on the printed circuit boards mounted in this unit.

Be sure to use lead-free solder and a soldering iron that can meet specifications for use with lead-free solders for repairs accompanied by reworking of soldering.

• Compared with conventional eutectic solders, lead-free solders have higher melting points, by approximately 40 °C.

Therefore, for lead-free soldering, the tip temperature of a soldering iron must be set to around 373 °C in general, although the temperature depends on the heat capacity of the PC board on which reworking is required and the weight of the tip of the soldering iron.

Compared with eutectic solders, lead-free solders have higher bond strengths but slower wetting times and higher melting temperatures (hard to melt/easy to harden).

The following lead-free solders are available as service parts:

• Parts numbers of lead-free solder:

GYP1006 1.0 in dia.

GYP1007 0.6 in dia.

GYP1008 0.3 in dia.

1.2 NOTES ON HANDLING THE HDD

(1) Cautions on Handling the HDD

- The HDD is very sensitive to shocks and vibrations. Care must be taken especially during operation (when the power is on).
- The HDD is very sensitive to electrostatic charges.
- Rapid change in temperature or humidity may cause deterioration of the HDD.

Note: After receiving damage caused by any above-mentioned factors, the HDD may operate normally for dozens or some hundreds of hours but then suddenly crash. If you are certain you have damaged a new repair part (HDD) while making repairs, do not use the part.

The HDD is about 10 times as sensitive to shock during operation than during nonoperation.

Reference: Main specifications on damage to the HDD

	During operation	During nonoperation
Shock G (acceleration)	<approx. 20 G	<approx. 200 G
Temperature change	< 20°C/hour	
Moisture change	< 20%/hour	

Reference: Estimate value of falling distance vs. shock (G) when the HDD is dropped without protection

Falling distance	Landing surface	Granite surface	Concrete floor	Synthetic-resin-coated table	Antistatic sponge
0.5 inch / 12.7 mm		387	217	200	26
1.0 inch / 25.4 mm		595	457	310	37
2.0 inch / 50.8 mm		1133	600	680	70
4.0 inch / 101.6 mm		1795	1040	1050	267

(2) Cautions on handling the product on which the HDD is mounted or the HDD as a repair part, and examples of dangerous handling

[Cautions on handling the product on which the HDD is mounted]

- While the unit is turned on, the HDD is always in operation. Be sure NOT to impart shock to the unit.

● Examples of dangerous handling: while the power is on

- Bumping on the bonnet
- Dropping an object, such as a small screwdriver or remote control unit, onto the bonnet, or bumping an object against the cabinet
- Moving the unit by dragging
- Stacking another product on the unit

Note: Be sure NOT to impart shock, such as bumping or hitting a screwdriver against the HDD, during diagnosis with the bonnet open.

● Examples of dangerous handling: while the power is off

- Imparting strong shock, although the HDD is more resistant to shock when the power is off
- Dropping the unit from a height of several centimeters, or after lifting one side of the unit up, then letting the unit drop.
- Do NOT move the unit immediately after the power is turned off. Wait at least 30 seconds after the indication on the FL display changed from POWER OFF to the clock indication before moving the unit. If the AC power cord is accidentally disconnected before turning the unit off, wait at least for one minute before moving it. In this case, damage to the HDD caused by sudden shutoff may be small, because the emergency relief mechanism is activated. However, if sudden shutoff occurs during recording or playback, recorded data may be damaged. Be sure to check operations.

[Cautions on handling the HDD as a repair part]

1. Handle the HDD in a safe environment:
 - Handle the HDD over an antistatic pad that can also absorb shock.
 - Wear wrist bands to prevent electrostatic charges generated in your body from affecting the HDD.
2. The following must be observed when handling the HDD:
 - Handle one HDD at a time. Do NOT hold several HDDs at the same time.
 - Grip the HDD on both sides so that you do not touch its terminals or circuit boards.
 - Do NOT stack one HDD onto another HDD (even if the HDDs are protected in antistatic bags).
 - Do NOT bump the HDDs against one another.
 - Do NOT bump any tool, such as a screwdriver, or other hard object against the HDD.
 - When a repair part (HDD) is transported and there is a large temperature difference between outdoors and indoors, to the indoor, leave it in its package for about a half day to gradually cool or warm the HDD to room temperature before unpacking it.

[Notes on packing for shipment]

- When returning a defective HDD for analysis, handle with care as if it were a good product. Otherwise, the results of analysis may not be correct.
- When packing, use the antistatic bag and packing materials in which the repair part for service was delivered. Attach a copy of the slip for service or a memo stating symptoms in as much detail as possible.

■ Outline and part No. of the HDDs

*Pioneer's part No. is not stamped.

Model Name	Capacity	SEAGATE	
		Pioneer's Part No. (for service)	Manufacturer's Part No.
DVR-LX60	250GB	VXF1131	ST3250820SCE
DVR-550H-S DVR-550H-AV	160GB	VXF1137	WD1600AABS-xxPRAx

- When replacing the HDD, carefully check the capacity and manufacturer's part No. on the part label to avoid replacing with a similar but inappropriate product. You can also check the model No. of the mounted HDD on the Service mode screen.
- Do NOT use repair parts, such as commercially available HDDs, other than those designated above, as their functions, performance or reliability cannot be guaranteed.

Wistern Digital(160GB)

Seagate(250GB)

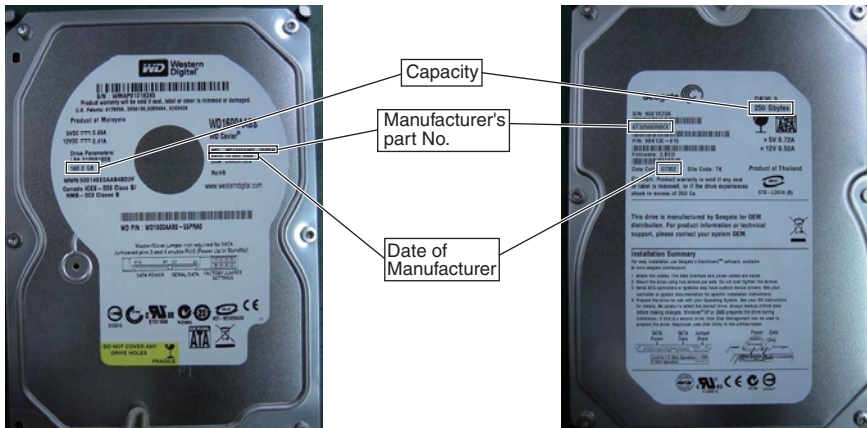

1.3 NOTES ON REPLACEMENT OF THE SDRAM

Note when replacing the SDRAM

When replacement of the SDRAM (IC1201 or IC1221) on the MAIN Assy is required, identify the manufacturer of the SDRAM. If the SDRAM that needs replacement was manufactured by ELPIDA, both IC1201 and IC1221 must be replaced at the same time.

SDRAMs for service are manufactured by SAMSUNG.

• How to identify the manufacturer

Confirm the name of the manufacturer stamped on the surface of the part.

By ELPIDA (replacement of both SDRAMs required)



By SAMSUNG (replacement of only the defective SDRAM possible)

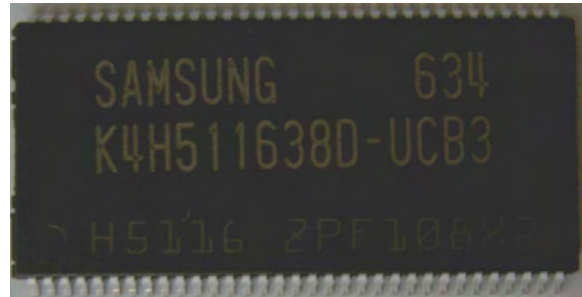

• Measures to be taken

- ① If the SDRAM that needs replacement was manufactured by ELPIDA:
Replace both IC1201 and IC1221 at the same time.
- ② If the SDRAM that needs replacement was manufactured by SAMSUNG:
Replacement of only the defective SDRAM (IC1201 or IC1221) is possible.

• Possible malfunctions

If SDRAMs made by different manufacturers are mounted on the MAIN Assy, the following malfunctions may occur:

- ① The power does not come on.
- ② High-speed dubbing disabled
- ③ Other malfunctions related to the SDRAM

1.4 NOTE ON INSULATORS AND THEIR SET SCREWS

For compliance with the safety standards, removal of the insulators and their set screws, as shown in the figure below, is prohibited. If they are removed, this product may not meet the official standards. NEVER remove these parts from the product.

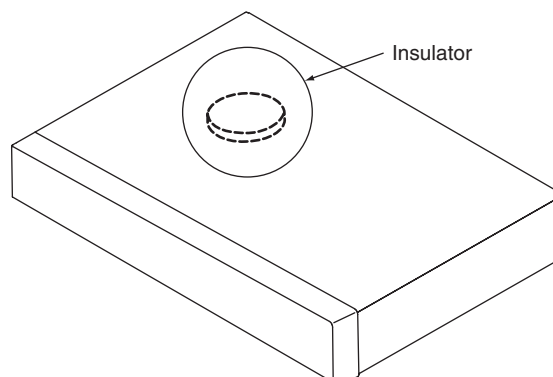

2. SPECIFICATIONS

2.1 ACCESSORIES

For DVR-LX60/WYXV5

- Remote control ×1 (VXX3222)



- Power cable ×1 (ADG1127)

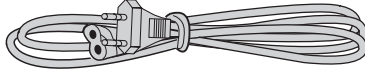

- Dry cell batteries ×2 (AA/R6P)



- RF antenna cable(PAL) ×1 (VDE1075)

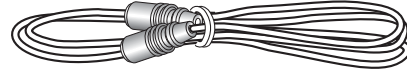

- Audio / Video cable(1.5m) ×1 (red/white/yellow) (VDE1077)

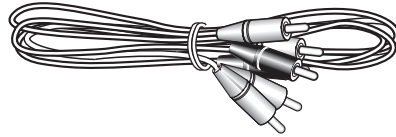

- G-Link™ Cable (3m) ×1 (VDX1010)

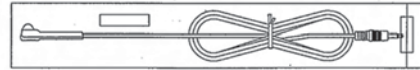

- Operating Instructions (French)(VRC1381)
- Operating Instructions (German)(VRC1386)
- Operating Instructions (Italian)(VRC1390)
- Operating Instructions (Dutch)(VRC1394)
- Operating Instructions (Spanish)(VRC1398)
- Warranty Card

2.2 SPECIFICATIONS

General

Power requirements 220 V to 240 V, 50 Hz/60 Hz
 Power consumption 48 W
 Power consumption in standby mode 0.67 W
 (Front panel display: off)
 Weight 4.6 kg
 Dimensions
 420 mm (W) x 77 mm (H) x 288 mm (D)
 Operating temperature +5 °C to +35 °C
 Operating humidity 5 % to 85 % (no condensation)
 TV system NTSC (external input only)
 /PAL/SECAM

Readable discs

DVD-Video, DVD-RW, DVD-R, DVD+R, DVD+RW,
 DVD-RAM, Video CD, Super VCD, CD, CD-R/-RW
 (WMA, MP3, JPEG, CD-DA, DivX)

Recording discs and formats

DVD-R/-RW: VR mode and Video mode
 DVD+R/+RW: +VR mode
 DVD-RAM: VR mode
 DVD-R DL: VR mode and Video mode
 DVD+R DL: +VR mode

Video recording format

Sampling frequency 13.5 MHz
 Compression format MPEG

Audio recording format

Sampling frequency 48 kHz
 Compression format Dolby Digital or Linear PCM
 (uncompressed)

Recording time

HDD (250 GB)

XP+ Approx. 36 h
 Fine (XP) Approx. 53 h
 Standard Play (SP) Approx. 106 h
 Long Play (LP) Approx. 212 h
 Extended Play (EP) Approx. 319 h
 Super Long Play (SLP) Approx. 425 h
 Super Extended Play (SEP) Approx. 532 h
 Manual Mode (MN) Approx. 36 h to 711 h

DVD-R/-RW, DVD+R/+RW, DVD-RAM

Fine (XP) Approx. 1 h
 Standard Play (SP) Approx. 2 h
 Long Play (LP) Approx. 4 h
 Extended Play (EP) Approx. 6 h
 Super Long Play (SLP) Approx. 8 h
 Super Extended Play (SEP) Approx. 10 h
 (DVD-R/-RW, DVD-RAM only)

Manual Mode (MN)

DVD-R/-RW/-RAM Approx. 1 h to 13 h
 DVD+R/+RW Approx. 1 h to 8 h

DVD-R DL/DVD+R DL

Fine (XP) Approx. 1 h 51 m
 Standard Play (SP) Approx. 3 h 35 m
 Long Play (LP) Approx. 7 h 11 m
 Extended Play (EP) Approx. 10 h 46 m
 Super Long Play (SLP) Approx. 14 h 21 m
 Super Extended Play (SEP) Approx. 17 h 57 m
 (DVD-R DL only)

Manual Mode (MN)

DVD-R DL Approx. 1 h 51 m to 24 h
 DVD+R DL Approx. 1 h 51 m to 14 h 21 m

Timer

Programmes 1 month/32 programmes
 Clock Quartz lock (24-hour digital display)

Tuner

Receivable channels

	SECAM B/G		PAL I	
	Frequency	Channel	Frequency	Channel
VHF (low)	47 MHz to 89 MHz	E2 to E4 X to Z	44 MHz to 89 MHz	A to C X to Z
VHF (high)	104 MHz to 300 MHz	E5 to E12 S1 to S20 M1 to M10 U1 to U10	104 MHz to 300 MHz	D to J 11, 13 S1 to S20
Hyper	302 MHz to 470 MHz	S21 to S41	302 MHz to 470 MHz	S21 to S41
UHF	470 MHz to 862 MHz	E21 to E69	470 MHz to 862 MHz	E21 to E69

	SECAM L		SECAM D/K	
	Frequency	Channel	Frequency	Channel
VHF (low)	49 MHz to 65 MHz	FB, FC1, FC	49 MHz to 94 MHz	R1 to R5
VHF (high)	104 MHz to 300 MHz	F1 to F6 B to Q	104 MHz to 300 MHz	R6 to R12 S1 to S20
Hyper	300 MHz to 470 MHz	S21 to S41	302 MHz to 470 MHz	S21 to S41
UHF	470 MHz to 862 MHz	21 to 69	470 MHz to 862 MHz	E21 to E69

STEREO
 B/G - A2
 I - NICAM
 L - NICAM
 B/G - NICAM
 D/K - NICAM

Input/Output

VHF/UHF antenna input/output terminal	VHF/UHF set 75 Ω (IEC connector)
Video input	AV2 (Input 1), Input 2 (front), Input 3 (rear)
Input level	1 Vp-p (75 Ω)
Jacks	AV connector (Input 1), RCA jack (Input 2, Input 3)
Video output	AV1, Output
Output level	1 Vp-p (75 Ω)
Jacks	AV connector (AV1) RCA jack (Output)
S-Video input	AV2 (Input 1), Input 2 (front), Input 3 (rear)
Y (luminance) - Input level	1 Vp-p (75 Ω)
C (colour) - Input level	300 mVp-p (75 Ω)
Jacks	AV connector (Input 1), 4 pin mini DIN (Input 2, Input 3)
S-Video output	AV1, Output
Y (luminance) - Output level	1 Vp-p (75 Ω)
C (colour) - Output level	300 mVp-p (75 Ω)
Jacks	AV connector (AV1), 4 pin mini DIN (Output)
Component video output	Y: 1.0 Vp-p (75 Ω) PB, PR: 0.7 Vp-p (75 Ω)
Jacks	RCA jacks
RGB input	AV2 (Input 1)
Input level	0.7 Vp-p (75 Ω)
Jacks	AV connector (Input 1)
RGB output	AV1
Output level	0.7 Vp-p (75 Ω)
Jacks	AV connector (AV1)
Audio input	AV2 (Input 1), Input 2 (front), Input 3 (rear) L/R
Input level	2 V rms (Input impedance: more than 22 k Ω)
Jacks	AV connector (Input 1), RCA jacks (Input 2)
Audio output	AV1, Output
During audio output	2 V rms (Output impedance: less than 1.5 k Ω)
Jacks	AV connector (AV1), RCA jacks (Output)
Control input	Mini jack
Digital audio output	Coaxial
G-LINK™	Mini jack
DV input	4 pin (front) (i.LINK/IEEE 1394 standard)
USB	Type A (front), Type B (front)
HDMI	19 pin

AV Connectors (21-pin connector assignment)

AV connector input/output 21-pin connector
This connector provides the video and audio signals
for connection to a compatible colour TV or monitor.

1 3 5 7 9 11 13 15 17 19 21

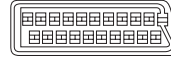

2 4 6 8 10 12 14 16 18 20

PIN no.	AV1 (RGB)-TV / AV2 (INPUT 1/DECODER)
1	Audio 2/R out / Audio 2/R out
2	- / Audio 2/R in
11	G out / G in
3	Audio 1/L out / Audio 1/L out
6	- / Audio 1/L in
15	R or C out / R or C in
4	GND
17	GND
7	B out / B in
19	Video out or Y out / Video out
20	- / Video in or Y in
8	Status
21	GND

Supplied accessories

















Remote control	1
Dry cell batteries (AA/R6P)	2
Audio/Video cable (red/white/yellow)	1
G-LINK™ cable	1
RF antenna cable	1
Power cable	1
Operating Instructions	1
Warranty card	1

Note: The specifications and design of this product are
subject to change without notice, due to improvement.

This product includes FontAvenue® fonts licenced
by NEC corporation. FontAvenue is a registered
trademark of NEC Corporation.

Microsoft product screen shots reprinted with
permission from Microsoft Corporation.

2.3 DISC/CONTENT FORMAT

	HDD	DVD-R	DVD-RW	DVD+R	DVD+RW	DVD-RAM		
Marks used in this manual		 	 					
		*1	*1	*2		*13, 16		
Logos			 					
								
Re-recordable/ Erasable	●	*3	*3	●	●	*3	● *14	●
Editing of recorded programmes	●	●	● *4	●	● *4	● *4	● *4	●
Recording of Copy- once protected material	●	● *12		● *12				● *12
Playback in other players/recorders	n/a	*5	● *6	*7	● *6	● *6, 15	● *8	● *9
Chase play	●							
16:9 and 4:3 programme recording	●	●		●				●
Bilingual broadcast recording of both audio channels	● *10, 11	● *11		● *11				● *11

Notes to table

- *1 Must be initialized for VR mode recording .
- *2 Must be initialized for Video mode recording.
- *3 Erasable, but free space does not increase.
- *4 Cannot erase sections, edit chapters or use playlist editing.
- *5 Must be compatible with DVD-R (VR) playback.
- *6 Finalize using this recorder (may not playback in some units).
- *7 Must be compatible with DVD-RW (VR) playback.
- *8 Must be compatible with DVD+RW playback.
- *9 Must be compatible with DVD-RAM playback.
- *10 Only when HDD Recording Format is set to Video Mode Off .

- *11 Only when the recording mode is not set to LPCM.
- *12 CPRM-compatible discs only.
- *13 Take the disc out of the cartridge before use. Only Panasonic and Maxell discs have been tested to work reliably with this recorder. Discs from other makers may become unusable when recorded or edited.
- *14 Erasing a title does not increase the available recording time, nor increase the number of recordable titles left.
- *15 Must be compatible with DVD+R playback.
- *16 Depending on the disc, it may have to be initialized before it can be recorded. In this case, initialization will take about an hour.

 is a trademark of DVD Format/Logo Licensing Corporation.

Using DVD-R DL/DVD+R DL discs

DVD-R DL (Dual-Layer) and DVD+R DL (Double-Layer) discs contain two recordable layers on a single side, giving about 1.8 times the recording capacity of a conventional single-layer disc. This unit can record to both DVD-R DL and DVD+R DL discs.

- If you intend to play DVD-R DL (Video mode) or DVD+R DL discs recorded on this unit on other DVD recorders/players, you must finalize them. (Note that some DVD recorders/players may not play even finalized DL discs.)
- This logo indicates that the disc is a DVD-R DL or DVD+R DL disc:



Correct operation has been confirmed for DL discs:

- DVD-R DL ver. 3.0/2x to 4x
Mitsubishi Kagaku Media (Verbatim)
- DVD-R DL ver. 3.0/2x to 8x
Mitsubishi Kagaku Media (Verbatim)
That's
JVC
- DVD+R DL 2.4x
Mitsubishi Kagaku Media (Verbatim)
RICOH
- DVD+R DL 2.4x to 8x
Mitsubishi Kagaku Media (Verbatim)
RICOH

About DualDisc playback

A DualDisc is a new two-sided disc, one side of which contains DVD content –video, audio, etc. –while the other side contains non-DVD content such as digital audio material.

The non-DVD, audio side of the disc is not compliant with the CD Audio specification and therefore may not play.

It is possible that when loading or ejecting a DualDisc, the opposite side to that being played will be scratched. Scratched discs may not be playable.

The DVD side of a DualDisc plays in this product. DVD-Audio content will not play.

For more detailed information on the DualDisc specification, please refer to the disc manufacturer or disc retailer.

Other disc compatibility

In addition to DVD, this recorder is compatible with a wide range of disc types (media) and formats. Playable discs will generally feature one of the logos on the disc and/or disc packaging shown below. Note however that some disc types, such as recordable CD (and DVD), may be in an unplayable format — see below for further compatibility information.



CD-R/-RW compatibility

This recorder cannot record CD-R or CD-RW discs.

- Readable formats: CD-Audio, Video CD/ Super VCD, ISO 9660 CD-ROM* containing MP3, WMA, JPEG or DivX files
*ISO 9660 Level 1 or 2 compliant. CD physical format: Mode1, Mode2 XA Form1. Romeo and Joliet file systems are both compatible with this recorder.
- Multi-session playback: Yes (except CD-Audio and Video CD/Super VCD)
- Unfinalized disc playback: CD-Audio only

Compressed audio compatibility

- Compatible media: DVD-ROM, DVD-R/-RW, DVD+R/+RW, DVD-RAM, CD-ROM, CD-R, CD-RW, USB
- Compatible formats: MPEG-1 Audio Layer 3 (MP3), Windows Media Audio (WMA)

- Sampling rates: 32 kHz, 44.1 kHz or 48 kHz
- Bit-rates: Any (128 kbps or higher recommended)
- Variable bit-rate (VBR) MP3 playback: Yes
- VBR WMA playback: No
- WMA encoder compatibility: Windows Media Codec 8(files encoded using Windows Media Codec 9 may be playable but some parts of the specification are not supported; specifically, Pro, Lossless, Voice and VBR)
- DRM (Digital Rights Management)¹ file playback: No
- File extensions: .mp3, .wma (these must be used for the recorder to recognize MP3 and WMA files – do not use for other file types)
- File structure: Up to 99 folders / 999 files (if these limits are exceeded, only files and folders up to these limits are playable)

WMA (Windows Media™ Audio) compatibility

This recorder can playback Windows Media Audio content.

WMA is an acronym for Windows Media Audio and refers to an audio compression technology developed by Microsoft Corporation. WMA content can be encoded by using Windows Media Player for Windows XP, Windows Media Player 9 or Windows Media Player 10 series.

Windows Media is a trademark of Microsoft Corporation.

This product includes technology owned by Microsoft Corporation and cannot be used or distributed without a license from Microsoft Licensing, Inc.

Note

¹ DRM (digital rights management) copy protection is a technology designed to prevent unauthorized copying by restricting playback, etc. of compressed audio files on devices other than the PC (or other recording equipment) used to record it. For detailed information, please see the instruction manuals or help files that came with your PC and/or software.

DivX video compatibility



DivX is a compressed digital video format created by the DivX[®] video codec from DivX, Inc. This recorder can play DivX video files burned on CD-R/-RW/-ROM discs. Keeping the same terminology as DVD-Video, individual DivX video files are called "Titles". When naming files/titles on a CD-R/-RW disc prior to burning, keep in mind that by default they will be played in alphabetical order.

- Official DivX[®] Certified product.
- Plays all versions of DivX[®] video (including DivX[®] 6) with standard playback of DivX[®] media files.
- File extensions: .avi and .divx (these must be used for the recorder to recognize DivX video files). Note that all files with the .avi extension are recognized as MPEG4, but not all of these are necessarily DivX video files and therefore may not be playable on this recorder.
- File structure: Up to 99 folders or 999 files.

DivX, DivX Certified, and associated logos are trademarks of DivX, Inc. and are used under license.

DivX® VOD content



In order to play DivX VOD (video on demand) content on this recorder, you first need to register the recorder with your DivX VOD content provider. You do this by generating a DivX VOD registration code, which you submit to your provider.

Some DivX VOD content may only be playable a fixed number of times. When you load a disc containing this type of DivX VOD content, the remaining number of plays is shown on-screen and you then have the option of playing the disc (thereby using up one of the remaining plays), or stopping. If you load a disc that contains expired DivX VOD content (for example, content that has zero remaining plays), the message **Rental Expired** is displayed.

If your DivX VOD content allows an unlimited number of plays, then you may load the disc into your recorder and play the content as often as you like, and no message will be displayed.

Important

- DivX VOD content is protected by a DRM system. This restricts playback of content to specific, registered devices.
- If you load a disc that contains DivX VOD content not authorized for this recorder, the message **Authorization Error** is displayed and the content will not play.
- Resetting the recorder will not cause you to lose your registration code.

JPEG file compatibility

- Compatible formats: Baseline JPEG and EXIF 2.2* still image files
*File format used by digital still cameras
- Sampling ratio: 4:4:4, 4:2:2, 4:2:0
- Horizontal resolution: 160 to 5120 pixels
- Vertical resolution: 120 to 3840 pixels
- Progressive JPEG compatible: No

- File extensions: .jpg, .jpeg, .jpe, .jif, .jfif (must be used for the recorder to recognize JPEG files – do not use for other file types)
- File structure: The recorder can load up to 99 folders/999 files at one time (if there are more files/folders than this on the disc then more can be reloaded)

PC-created disc compatibility

Discs recorded using a personal computer may not be playable in this unit due to the setting of the application software used to create the disc. In these particular instances, check with the software publisher for more detailed information.

Discs recorded in packet write mode (UDF format) are not compatible with this recorder.

Check the DVD-R/-RW or CD-R/-RW software disc boxes for additional compatibility information.

Dolby Digital



Manufactured under license from Dolby Laboratories. "Dolby" and the double-D symbol are trademarks of Dolby Laboratories.

DTS



"DTS" and "DTS Digital Out" are registered trademarks of DTS, Inc.

2.4 PANEL FACILITIES

◆ Rear Panel

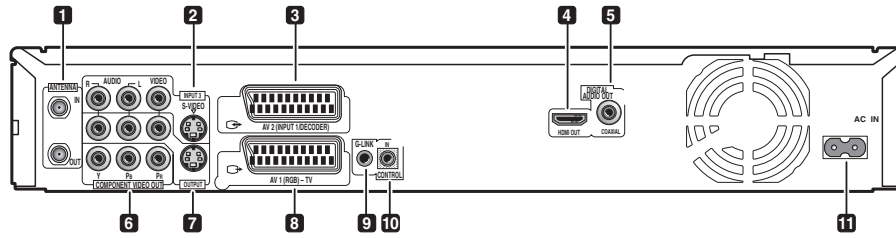

1 ANTENNA IN (RF IN)/OUT

Connect your TV antenna to the **ANTENNA IN (RF IN)** jack. The signal is passed through to the **ANTENNA OUT** jack for connection to your TV.

2 INPUT 3

Stereo analog audio, video and S-video inputs for connection to a VCR or other source component.

3 AV2 (INPUT 1/DECODER) AV connector

Audio/video input/output SCART-type AV connector for connecting to a VCR, or other equipment with a SCART connector. The input accepts video, S-video and RGB.

4 HDMI OUT

HDMI output for high quality digital audio and video.

5 DIGITAL AUDIO OUT

Coaxial digital audio jack for connecting to an AV amplifier/receiver, Dolby Digital/DTS/MPEG decoder or other equipment with a digital input.

6 COMPONENT VIDEO OUT

A high-quality video output for connecting to a TV or monitor with a component video input.

7 OUTPUT

Stereo analog audio, video and S-video outputs for connection to a TV or AV amplifier/receiver.

8 AV1 (RGB)-TV AV connector

Audio/video output SCART-type AV connector for connecting to a TV or other equipment with a SCART connector. The video output is switchable between video, S-video and RGB.

9 G-LINK™

Use to connect the supplied G-LINK™ cable to enable GUIDE Plus+™ to control an external satellite receiver, etc.

10 CONTROL IN

Use to control this recorder from the remote sensor of another Pioneer component with a **CONTROL OUT** terminal and bearing the Pioneer  mark. Connect the **CONTROL OUT** of the other component to the **CONTROL IN** of this recorder using a mini-plug cord.

11 AC IN – Power inlet

◆ Front panel

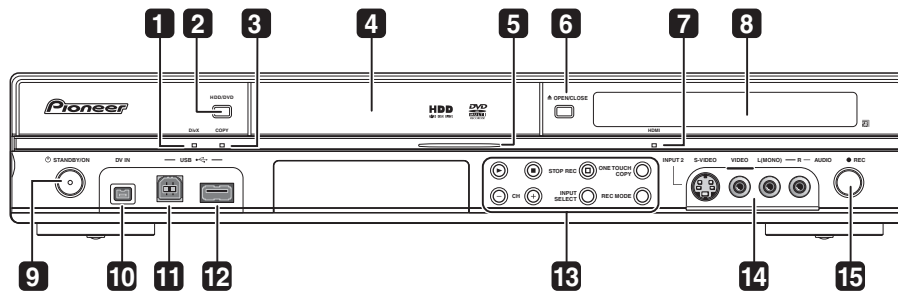

1 DivX indicator

Lights when this recorder plays DivX video files.

2 HDD/DVD

Press to switch between HDD and DVD for recording and playback.

3 COPY indicator

Lights when copying is underway.

4 Disc tray

Indicator lights blue when the hard disk (HDD) is selected; orange when the DVD drive is selected.

6 ▲ OPEN/CLOSE

Press to open/close the disc tray.

7 HDMI indicator

Lights when this recorder is connected to HDMI (HDCP) compatible component.

8 Front panel display and IR remote sensor

9 ⏻ STANDBY/ON

Press to switch the recorder on/into standby.

10 DV IN

A DV input i.LINK connector, suitable for connecting a DV camcorder.

11 USB port (Type B)

USB port for connecting a PictBridge-compatible printer or PC.

12 USB port (Type A)

USB port for connecting a digital camera, keyboard or other USB device.

13 ▶

Press to start or restart playback.

Press to stop playback.

◻ STOP REC

Press to stop recording.

○ ONE TOUCH COPY

Press to start One Touch Copy of the currently playing title to DVD or the HDD.

CH +/-

Use to change channels, skip chapters/tracks, etc.

INPUT SELECT

Press to change the input used for recording.

REC MODE

Press repeatedly to cycle through recording modes (picture quality).

14 INPUT 2

Audio/video input (stereo analog audio; composite and S-video), especially suitable for camcorders, game consoles, portable audio, etc.

15 ● REC

Press to start recording. Press repeatedly to set the recording time in 30 minute blocks.

◆ Display

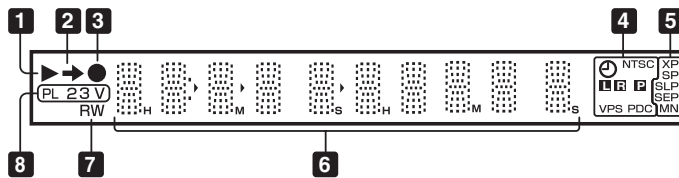

1 ▶

Lights during playback; blinks when playback is paused.

2 ➔

Lights when copying.

3 ●

Lights during recording; blinks when recording is paused.

4 ⌚

Lights when a timer recording has been set. (Indicator blinks if the timer has been set to DVD but there isn't a recordable disc loaded, or the timer has been set to HDD but the HDD is not recordable.)

NTSC

Lights when the video output signal format is NTSC.

Ⓛ Ⓜ

Indicates which channels of a bilingual broadcast are recorded.

Ⓜ

Lights when the component video output is set to progressive scan.

VPS/PDC

Lights when receiving a VPS/PDC broadcast during a VPS/PDC-enabled timer recording.

5 Recording quality indicators

XP

Lights when the recording mode is set to **XP** (high quality).

SP

Lights when the recording mode is set to **SP** (standard play).

LP/SLP

Lights when the recording mode is set to **LP** (long play) or **SLP** (super-long play).

EP/SEP

Lights when the recording mode is set to **EP** (extended play) or **SEP** (super-extended play).

MN

Lights when the recording mode is set to **MN** (manual recording level) mode.

6 Character display

7 R/RW

Lights when a recordable DVD-R or DVD-RW disc is loaded.

8 PL

Lights when a VR mode disc is loaded and the recorder is in Play List mode.

2 3

Shows the remote control mode (if nothing is displayed, the remote control mode is 1).

V

Lights when an unfinalized Video mode disc is loaded.

◆ Remote Control Unit

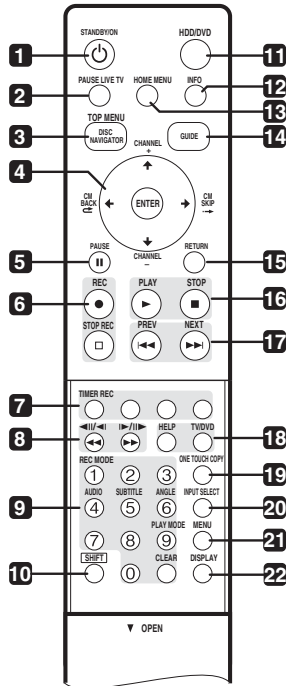

1 STANDBY/ON

Press to switch the recorder on/into standby.

2 PAUSE LIVE TV

Press to start recording the current TV channel, but with playback paused, effectively pausing the broadcast.

3 DISC NAVIGATOR / TOP MENU

Press to display the Disc Navigator screen, or the top menu if a DVD-Video or finalized DVD-R/-RW (Video) disc is loaded.

4 and ENTER

Used to navigate all on-screen displays. Press **ENTER** to select the currently highlighted option.

CM BACK (commercial back)

Press repeatedly to skip progressively backward through the video playing.

CM SKIP (commercial skip)

Press repeatedly to skip progressively forward through the video playing.

CHANNEL +/-

Press to change the channel of the built-in TV tuner.

5 PAUSE

Press to pause playback or recording.

6 Recording controls

REC

Press to start recording. Press repeatedly to set the recording time in blocks of 30 mins.

When the red action button is visible in a GUIDE Plus+™ screen, use for One-Button-Record.

STOP REC

Press to stop recording.

7 GUIDE Plus+™ Action buttons

When in the GUIDE Plus+™ system, these buttons act as the Red, Green, Yellow and Blue Action buttons (the functions of these buttons change according to the GUIDE Plus+™ Area).

TIMER REC

Hold **SHIFT** and press to set a timer recording from the GUIDE Plus+™ system.

8

Press to start reverse or forward scanning. Press again to change the speed.

While paused, press and hold to start slow-motion playback. Press repeatedly to change the playback speed.

While paused, press to advance a single frame in either direction.

When GUIDE Plus+™ is displayed, use to display the previous/next day.

9 Number buttons, CLEAR

Use the number buttons for track/ chapter/title selection; channel selection, and so on. The same buttons can also be used to enter names for titles, discs and so on.

Use **CLEAR** to clear an entry and start again.

REC MODE

Hold **SHIFT** and press repeatedly to change the recording mode (picture quality).

AUDIO

Hold **SHIFT** and press to change the audio language or channel. (When the recorder is stopped, press to change the tuner audio.)

SUBTITLE

Hold **SHIFT** and press to display/change the subtitles included in multilingual DVD-Video discs.

ANGLE

Hold **SHIFT** and press to switch camera angles on discs with multi-angle scenes.

PLAY MODE

Hold **SHIFT** and press to change the play mode (search, repeat, programme play, etc.).

10 SHIFT

Use to access functions on the remote printed in green.

11 HDD/DVD

Press to select the hard disk (HDD) or DVD for recording and playback.

12 INFO

Press to see additional information for the highlighted item in GUIDE Plus+™.

13 HOME MENU

Press to display the Home Menu, from which you can navigate all the functions of the recorder.

14 GUIDE

Press to display the GUIDE Plus+™ screen; press again to exit.

15 RETURN

Press to go back one level in the on-screen menu or display.

16 ► PLAY

Press to start playback.

■ STOP

Press to stop playback.

17 ◀◀ PREV ▶▶ NEXT

Press to skip to the previous or next title/ chapter/track/folder; or to display the previous or next menu page.

When GUIDE Plus+™ is displayed, use to display the previous/next page.

18 HELP

Press for help on how to use the current GUI screen.

TV/DVD

Press to switch between 'TV mode', in which you get the picture and sound from the TV's tuner, and 'DVD mode', in which you get picture and sound from the recorder's tuner (or an external input).

19 ONE TOUCH COPY

Press to start One Touch Copy of the currently playing title to DVD or the HDD.

20 INPUT SELECT

Press to change the input to use for recording.

21 MENU

Press to display the disc menu if a DVD-Video, finalized DVD-R/-RW (Video mode) or finalized DVD+R/+RW disc is loaded.

When in the GUIDE Plus+™ system, use to jump directly to the Menu bar.

22 DISPLAY

Displays/changes the on-screen information displays.

3. BASIC ITEMS FOR SERVICE

3.1 CHECK POINTS AFTER SERVICING

To keep the product quality after servicing, confirm recommended check points shown below.

No.	Procedures	Item to be checked
1	Confirm the firmware version on the first screen on Service Mode. Also check the compatibility of each firmware (OK or NG).	The version of each firmware must be the latest. All of firmware compatibility must be "OK". Update firmware to the latest one, if it is not the latest or the compatibility is "NG".
2	Confirm whether the customer complain has been solved. If the customer complain occurs with the specific disc, use it for the operation check.	The customer complain must not be reappeared. Video, audio and operations must be normal.
3	Perform the HDD physical test (Self-Test on HDD check mode).	"NG" must not be appeared.
4	Confirm playback error rates at the innermost and outermost tracks by using the following disc. DVD test disc (GGV1025)	The error rates must be less than 8.0e-4.
5	Record from the tuner (or an external source) to the HDD for 1 minute. After that, play back the content.	Video, audio and operations must be normal.
6	Copy the recorded content on the HDD in the previous step to a DVD-RW disc. After that, play back the disc.	Video, audio and operations must be normal.
7	Confirm the user setting, and whether the test-recorded content have been deleted.	Be sure to delete the test-recorded content on the HDD.
8	Check the appearance of the product.	No scratches or dirt on its appearance after receiving it for service.

See the table below for the items to be checked regarding video and audio:

Items to be checked regarding video	Item to be checked regarding audio
Block noise	Distortion
Horizontal noise	Noise
Dot noise	Volume too low
Disturbed image (video jumpiness)	Volume too high
Too dark	Volume fluctuating
Too bright	Sound interrupted
Mottled color	

◆ Necessary Procedure List When Replacing Assys

Following is the surely necessary procedures and the product state after changing, when replacing next ASSYs.

Replaced ASSY	Necessary setting	State after replacing	
		User setting	HDD contents
MAIN ASSY	1. Model setting 2. LD power adjustment 3. CPRM setting 4. Firmware update	×	○
TUSB ASSY	1. Model setting 2. CPRM setting 3. Firmware update	×	○
LOADER ASSY	1. LD power adjustment	○	○
HDD	1. CPRM setting	○	×

3.2 QUICK REFERENCE

Description of work	Procedure	Jigs
LD power adjustment	[ESC]+[CX]+[1]+[0]	GGF1381 : Service Remote Control Unit GGV1054 : CD-ROM (CDT-313) GGV1036 : DVD-ROM DL (DVDT-002) GGV1278 : Blank DVD-R (That's DR-C12WTY5PA) GGV1282 : Blank DVD-RW (JVC VD-W120XH5) GGV1284 : Blank DVD-RAM (maxell DRM120C.1P5S)
ID input	[ESC]+[STEREO]	GGF1381 : Service Remote Control Unit GGV1305 : ID disc
Firmware update	[REC STOP]+[PLAY]	Update disc
Version check	[ESC]+[DISP]	GGF1381 : Service Remote Control Unit
Error Rate Measurement	[ESC]+[DISP]+[DIG/ANA] × twice	GGF1381 : Service Remote Control Unit Operation check disc (See remarks)
HDD Check Mode	[ESC]+[CX]+[0]+[1]	GGF1381 : Service Remote Control Unit
Indication of VR-playback-related error log	[ESC]+[DISP]+[5]+[DIG/ANA]	GGF1381 : Service Remote Control Unit
Indication of VR-recording-related error log	[ESC]+[DISP]+[4]+[DIG/ANA] × 3times	GGF1381 : Service Remote Control Unit

Remarks

Disc for check of recording/playback operations	Operation check discs (manufacturers and model numbers)	Error rate threshold
(Note)	GGV1278 : Blank DVD-R (That's DR-C12WTY5PA)	1.0e-3 or below
When judging the drive quality, make sure to use the operation check disc.	GGV1279 : Blank DVD-R DL (MCM VHR21YD1)	L0 : 1.0e-3 or below L1 : 3.3e-3 or below
	GGV1280 : Blank DVD+R (That's DR+120TY5PA)	1.0e-3 or below
	GGV1281 : Blank DVD+R DL (MCM VTR21N1)	L0 : 1.0e-3 or below L1 : 3.3e-3 or below
	GGV1189 : Blank DVD-RW (JVC VD-W120N10)	1.0e-3 or below
	GGV1282 : Blank DVD-RW [RW2] (JVC VD-W120XH5)	1.0e-3 or below
	GGV1283 : Blank DVD+RW (RICOH D4RWV-S3CW)	1.0e-3 or below
	GGV1284 : Blank DVD-RAM (maxell DRM120C.1P5S)	1.0e-3 or below
	GGV1036 : DVD-ROM DL (DVDT-002)	L0/L1 : 8.0e-4 or below
How to read error rate	X.Xe-Y Y: The bigger the better, X X: The smaller the better	
How to exit from Service Mode	[ESC]	

3.3 PCB LOCATIONS

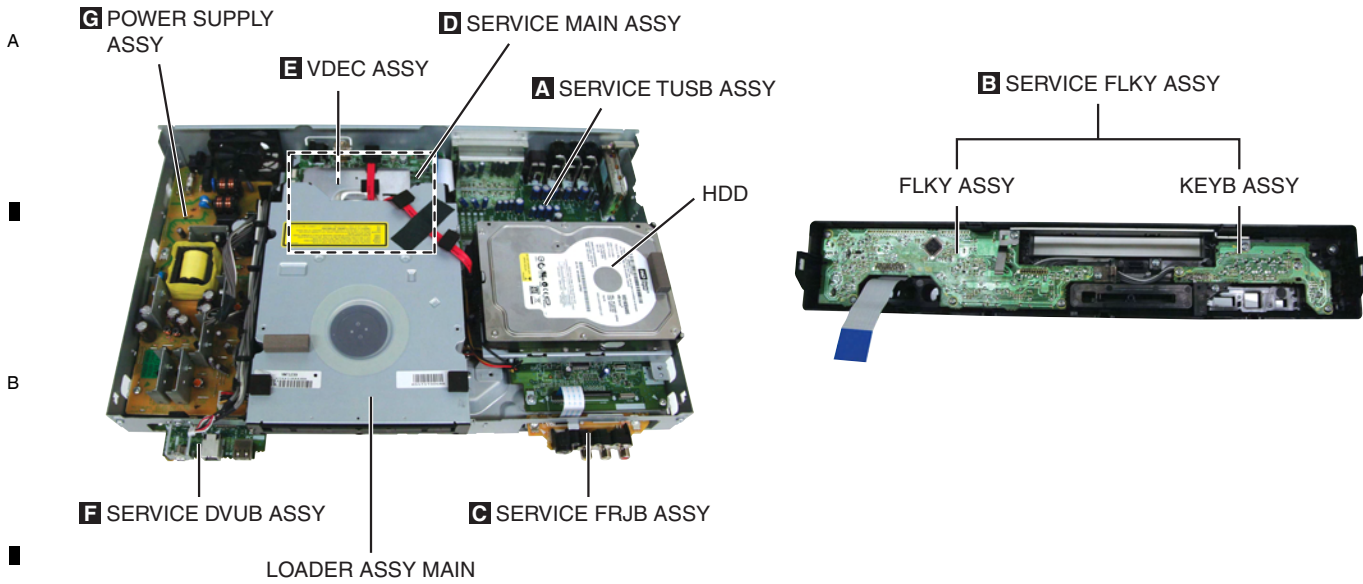

NOTES: ● Parts marked by "NSP" are generally unavailable because they are not in our Master Spare Parts List.
 ● The ⚠ mark found on some component parts indicates the importance of the safety factor of the part.
 Therefore, when replacing, be sure to use parts of identical designation.

◆ LIST OF ASSEMBLIES

Mark	No. Description	Part No.
NSP	1.. TUSB ASSY (DVR-LX60)	VWM2428
NSP	1.. TUSB ASSY (DVR-550H-S, DVR-550H-AV)	VWM2429
	2.. SERVICE TUSB ASSY	VXX3230
	2.. SERVICE DVUB ASSY (DVR-LX60)	VXX3231
	2.. SERVICE DVUB ASSY (DVR-550H-S, DVR-550H-AV)	VXX3232
NSP	1.. FLKB ASSY (DVR-LX60)	VWM2449
NSP	1.. FLKB ASSY (DVR-550H-S, DVR-550H-AV)	VWM2434
	2.. SERVICE FLKY ASSY (DVR-LX60)	VXX3259
	2.. SERVICE FLKY ASSY (DVR-550H-S, DVR-550H-AV)	VXX3226
	3.. FLKY ASSY	
	3.. KEYB ASSY	
	2.. SERVICE FRJB ASSY	VXX3227
	1.. VDEC ASSY	VWV2304
	1.. SERVICE MAIN ASSY (DVR-LX60)	VXX3241
	1.. SERVICE MAIN ASSY (DVR-550H-S, DVR-550H-AV)	VXX3240
⚠	1.. POWER SUPPLY ASSY	VWR1406

3.4 JIGS LIST

Jigs List

Name	Jig No.	Remarks
Service Remote Control Unit	GGF1381	Adjustment, diagnosis
DVD Test Disc (DVD-Video)	GGV1025	Check of DVD-Video
DVD Recorder Data Disc Type2	———— (*)	Diagnosis (ID data setting)
FFC Cable (40p)	GGD1436	Diagnosis of MAIN Assy
FFC Cable (28p)	GGD1517	Diagnosis of MAIN Assy
CD-ROM	GGV1054	LD Power Adjustment
DVD-ROM DL	GGV1036	LD Power Adjustment
Blank DVD-R	GGV1278	LD Power Adjustment
Blank DVD-RW	GGV1282	LD Power Adjustment
Blank DVD-RAM	GGV1284	LD Power Adjustment
Disc Ejection Rod	GGF1529	Emergency Disc Ejection

(*) Be sure to use the latest disc (Type 2).
In Feb, 2007, the latest disc is GGV1305.

Lubricants and Glues List

Name	Lubricants and Glues No.	Remarks
Hanarl	GEM1041	refer to "9.3 FRONT PANEL SECTION"

Cleaning



Before shipping out the product, be sure to clean the following positions by using the prescribed cleaning tools:

Position to be cleaned	Cleaning tools
Pickup lenses	Cleaning liquid : GEM1004 Cleaning paper : GED-008

Position to be cleaned	Cleaning tools
Fans	Cleaning paper : GED-008

4. BLOCK DIAGRAM

4.1 OVERALL WIRING DIAGRAM

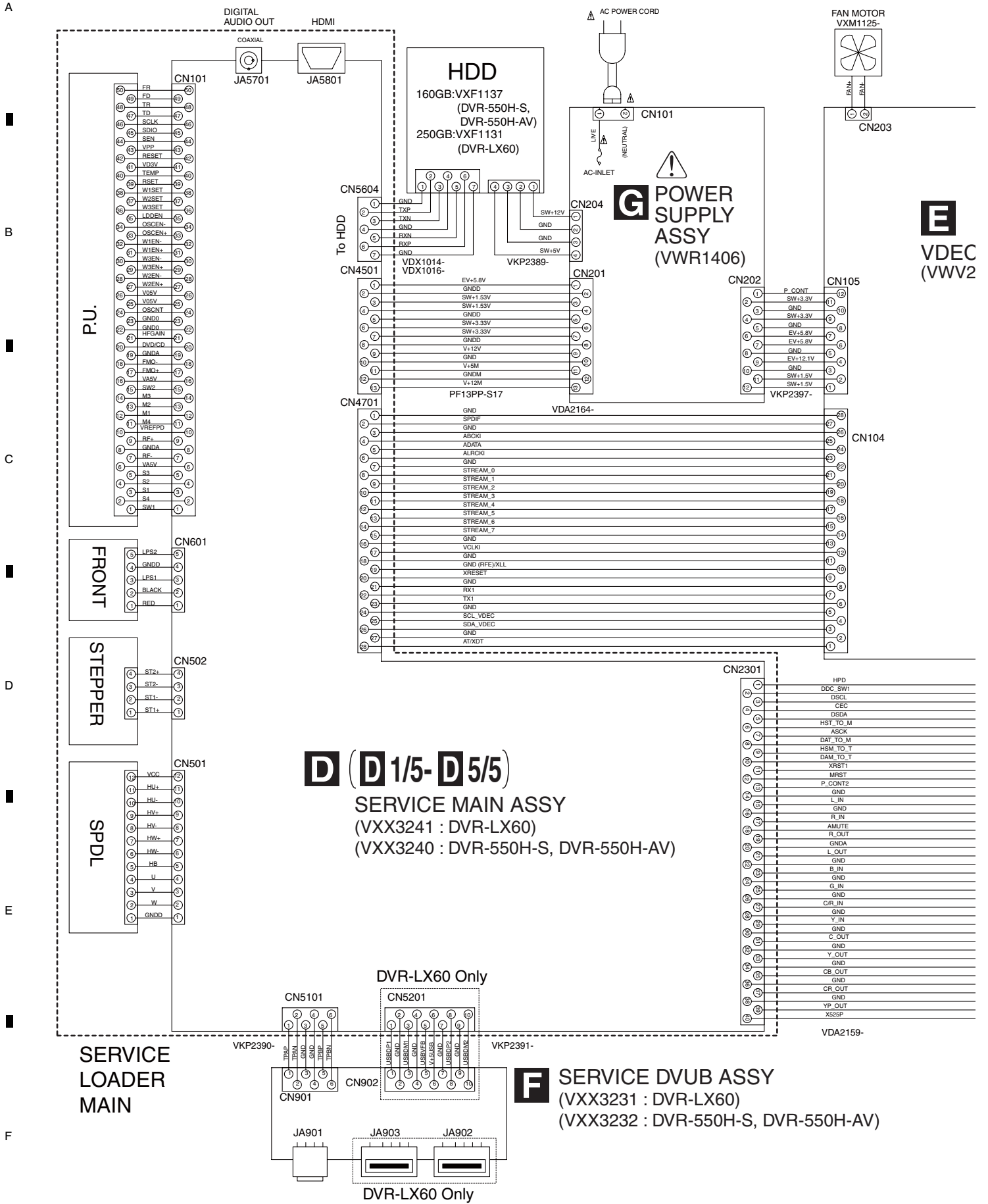



When ordering service parts, be sure to refer to "EXPLODED VIEWS and PARTS LIST" or "PCB PARTS LIST".
 The ⚠ mark found on some component parts indicates the importance of the safety factor of the part. Therefore, when replacing, be sure to use parts of identical designation.
 ⚡ : The power supply is shown with the marked box.

E
VDEC ASSY
 (VWV2304)

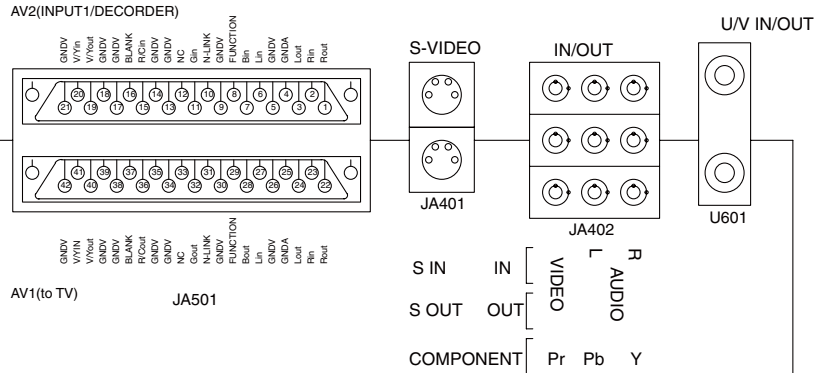
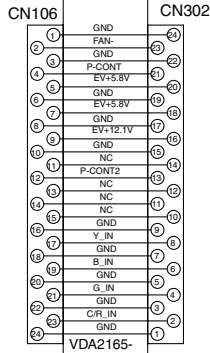

A (A 1/4- A 4/4)
SERVICE TUSB ASSY
 (VXX3230)

N104

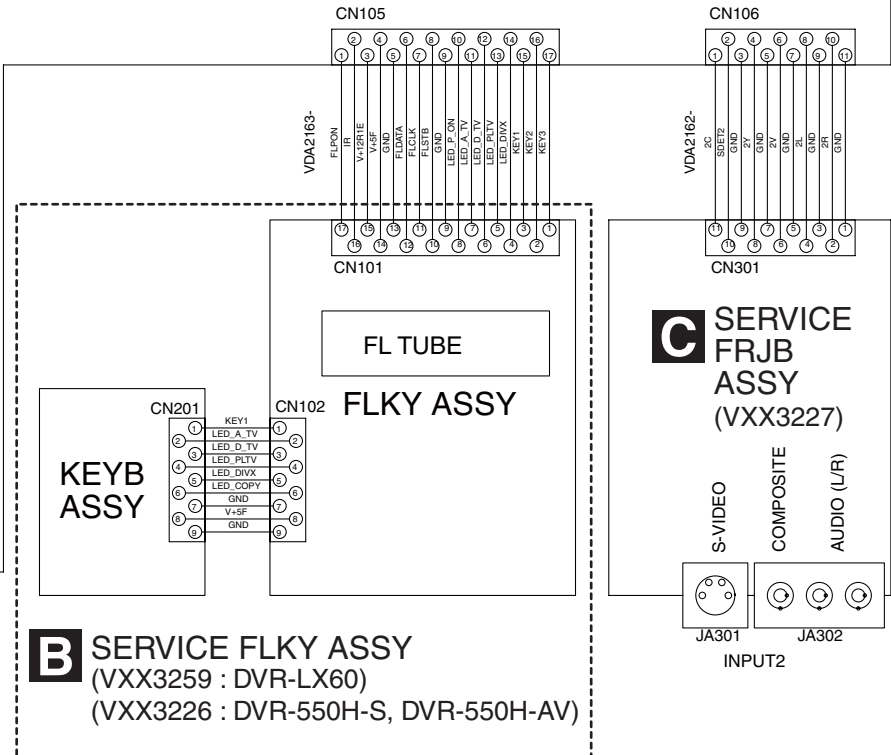
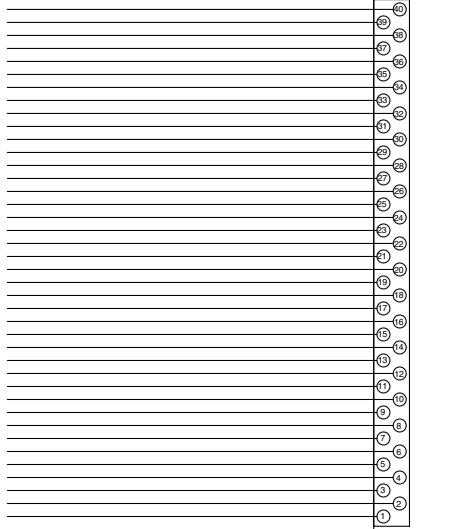

B
SERVICE FLKY ASSY
 (VXX3259 : DVR-LX60)
 (VXX3226 : DVR-550H-S, DVR-550H-AV)

V)

4.2 OVERALL BLOCK DIAGRAM

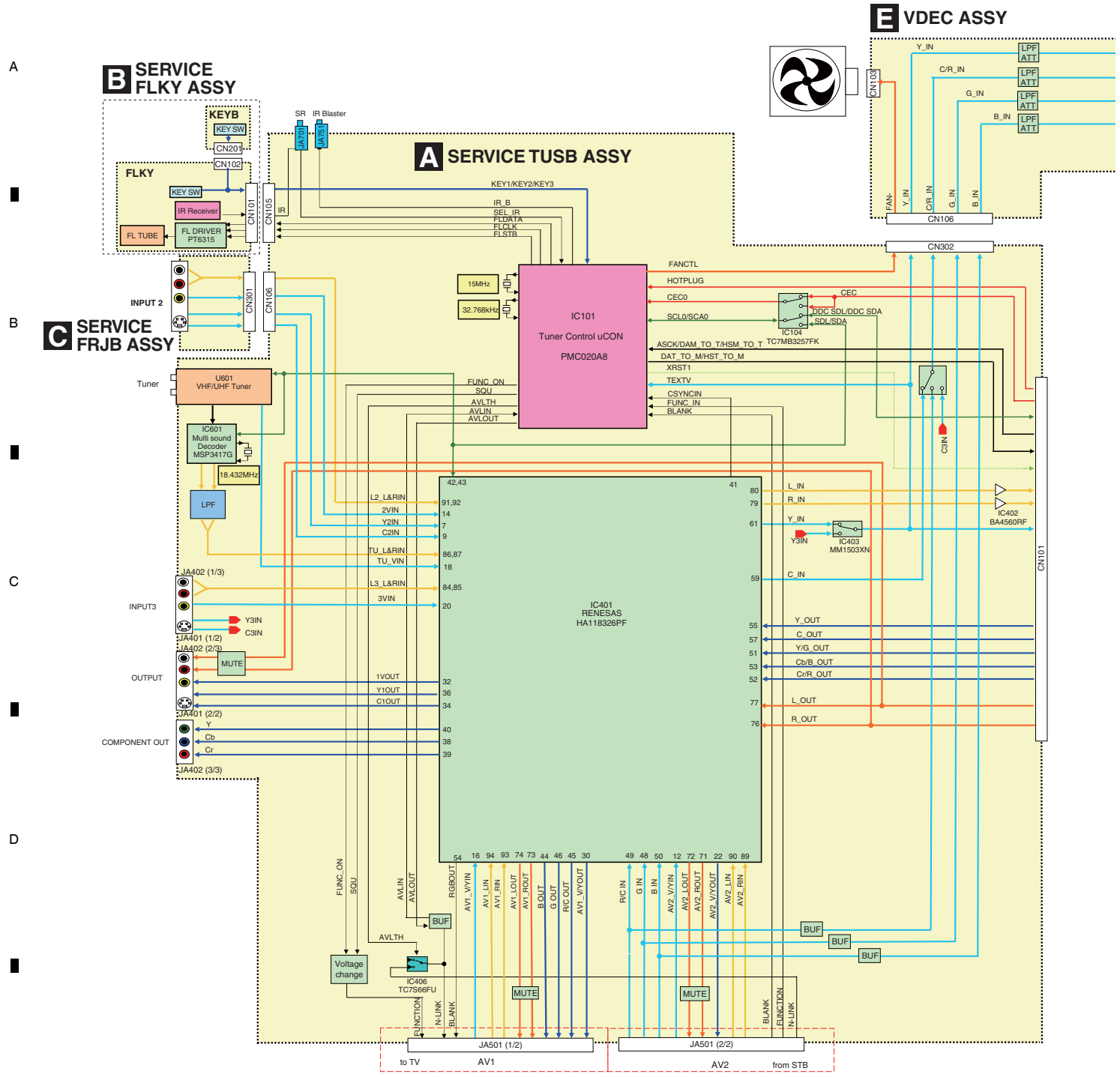

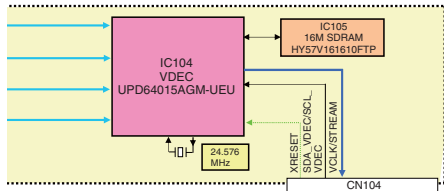

SERVICE DVUB ASSY

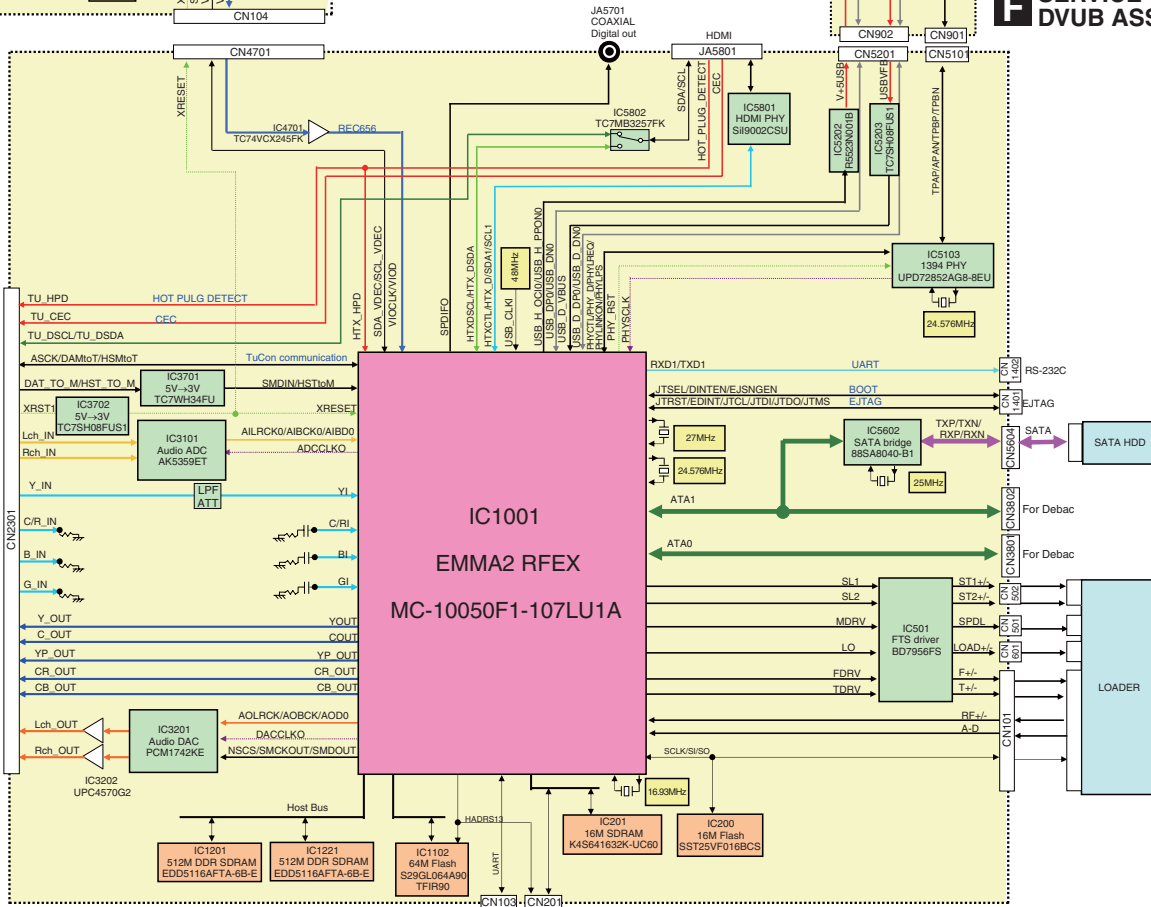

For FE ICE For Debac(232C)

SERVICE MAIN ASSY

A
B
C
D
E
F

4.3 DETECTION AND ENCODE SYSTEM BLOCK DIAGRAM

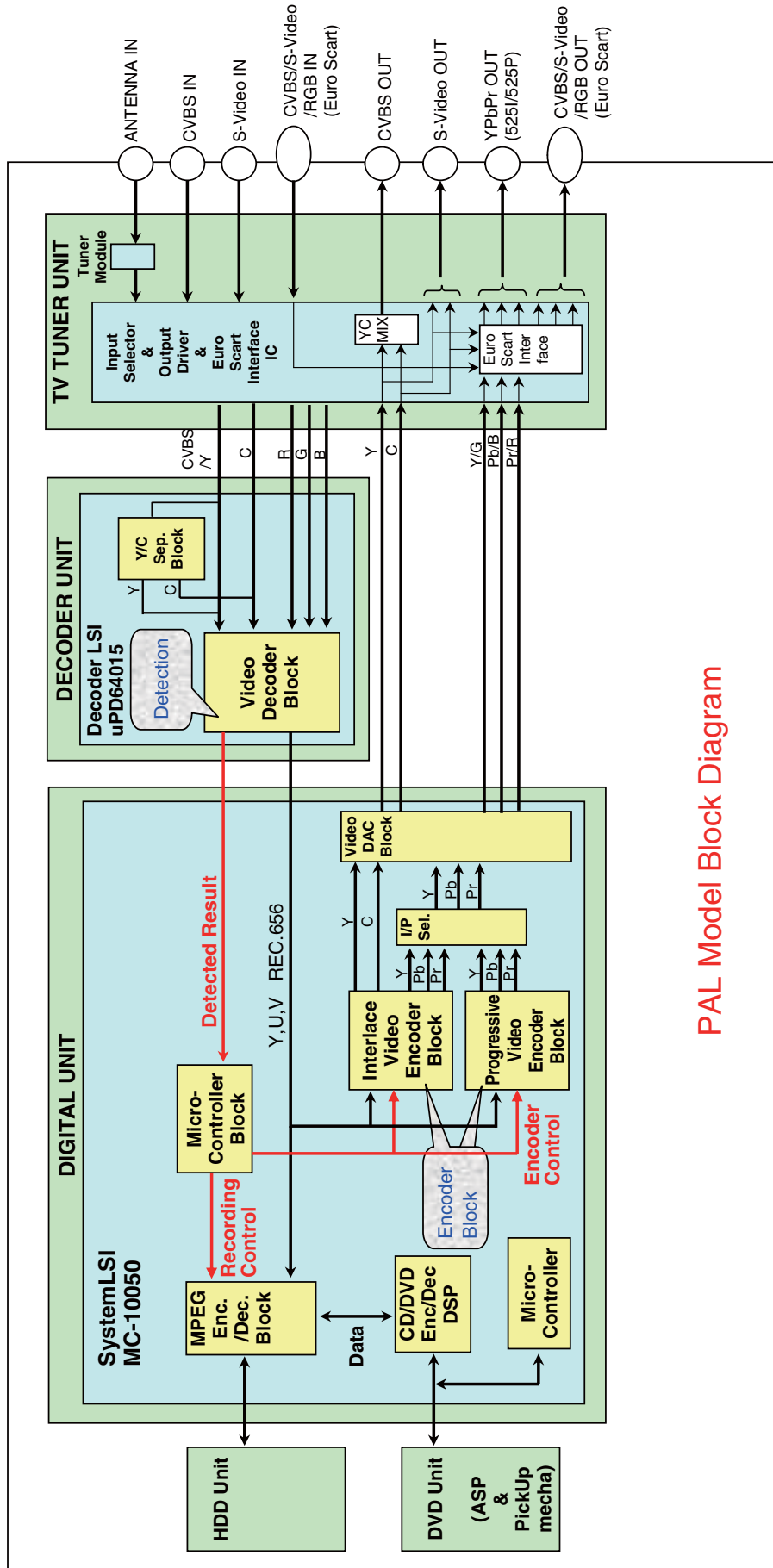

PAL Model Block Diagram

4.4 POWER BLOCK DIAGRAM

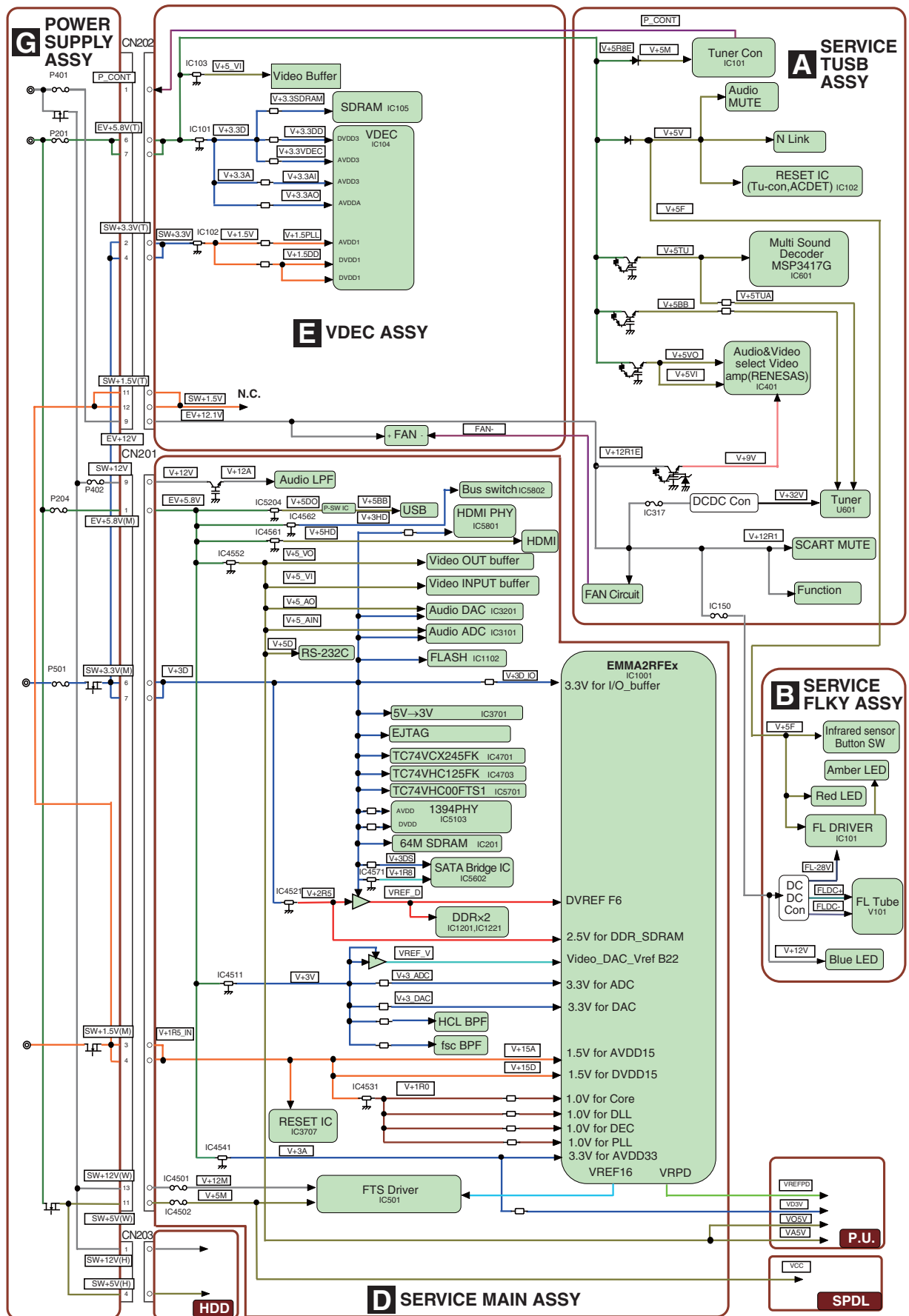

5. DIAGNOSIS

5.1 SETUP SEQUENCE

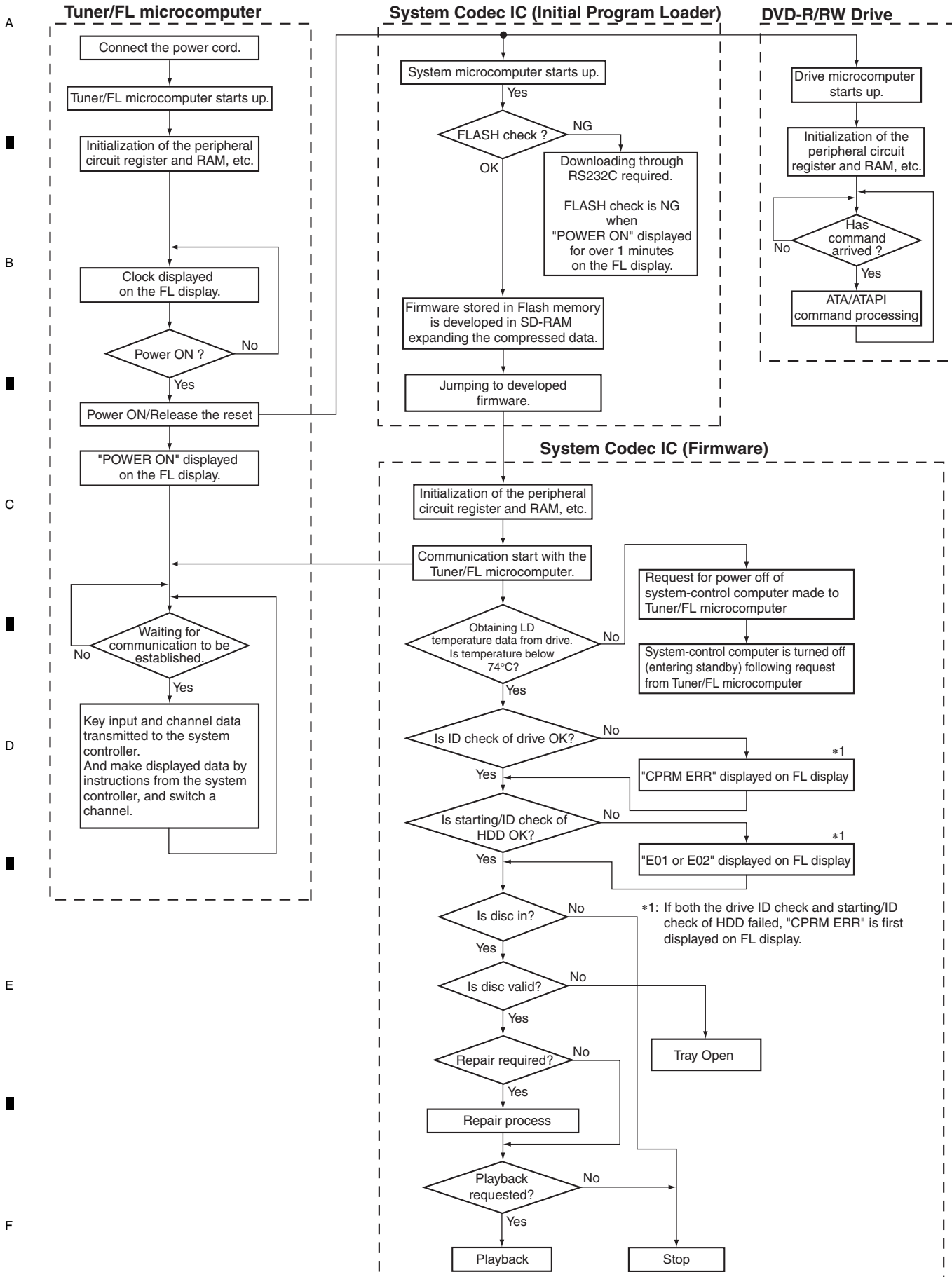

5.2 DIAGNOSIS OF THE MAIN ASSY

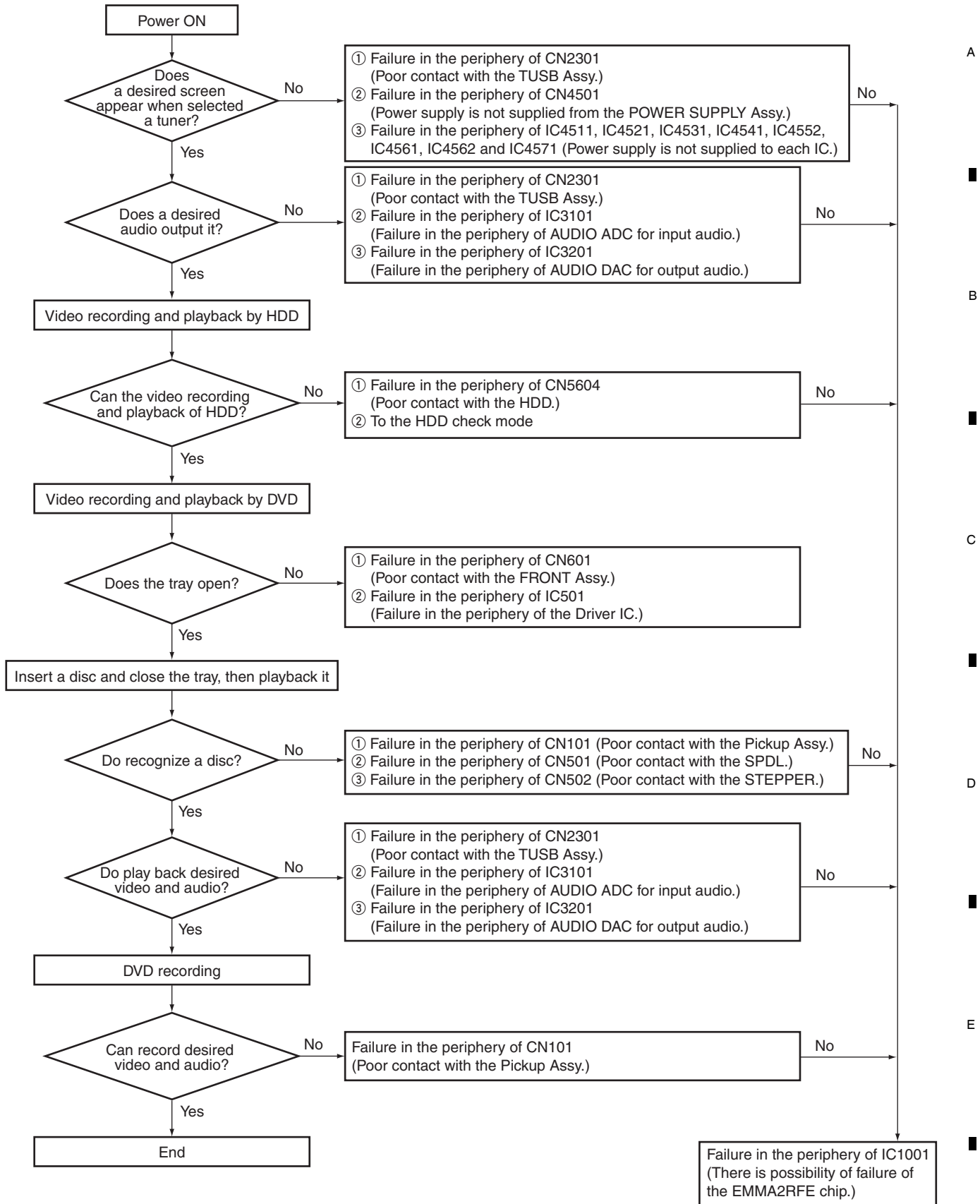

◆ Diagnosis of the HDMI Block

1. In a case when only the HDMI video is not outputted

A *This flowchart shows how to confirm the output from the HDMI block on the basis that an external input signal to the L1 connector is through-output from the analog output connector properly.

Connect the unit to a DVI monitor that is provided with the HDCP function (HDMI-DVI conversion connector required), or to a monitor that supports HDMI.

Set the input setting to L1. Input an external PAL signal to L1.

Is an image properly displayed?

YES

No

Are the images output successively (does HDMI LED light up)?

YES

AA

NO

Does it repeat correct output for a moment followed by black screen (or sandstorm)?

YES

Possible defect in EMMA2RFEX.

With the aid of an oscilloscope, check IC1001, IC5801 for the points listed below. (Only checking with a PAL signal is enough. Checking with an NTSC signal is not required):
• R5865 (HTX_CLK : 27 MHz/74.25 MHz/148.5 MHz @ PAL)
From the following points, a 3.3-V swing signal must be output:
• R5855 (H sync)
• R5855 (V sync)
• R5826 to R5828 (Video lines)

Are all the signals mentioned above output?

NO

YES

It is most likely that IC5801 and the subsequent parts are in failure. Check the soldering of the parts listed below:
• IC5801 itself
• L5801 to L5804, JA5801
• R5842 to R5845, C5815 to 5818

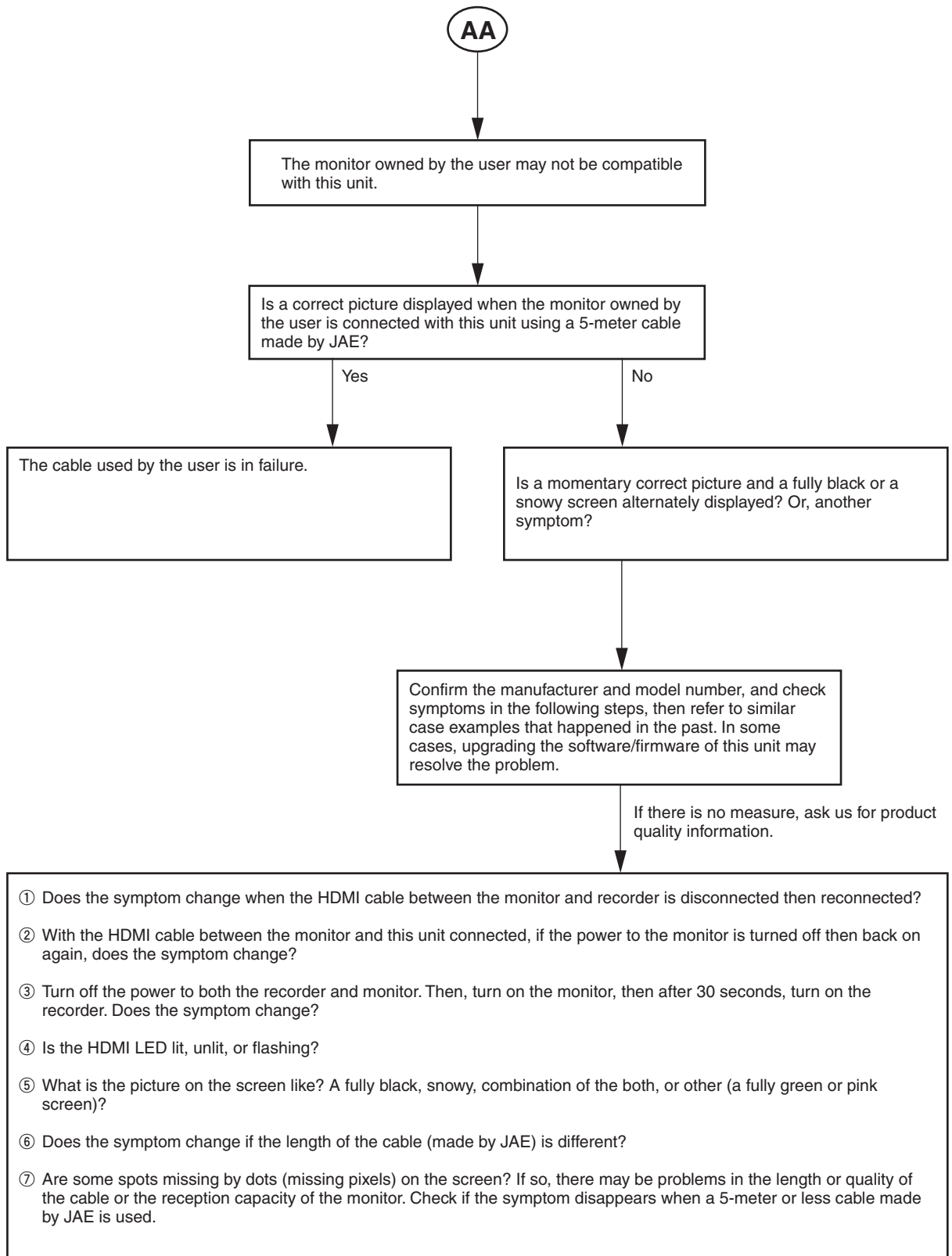

2. In a case when only the HDMI audio is not outputted

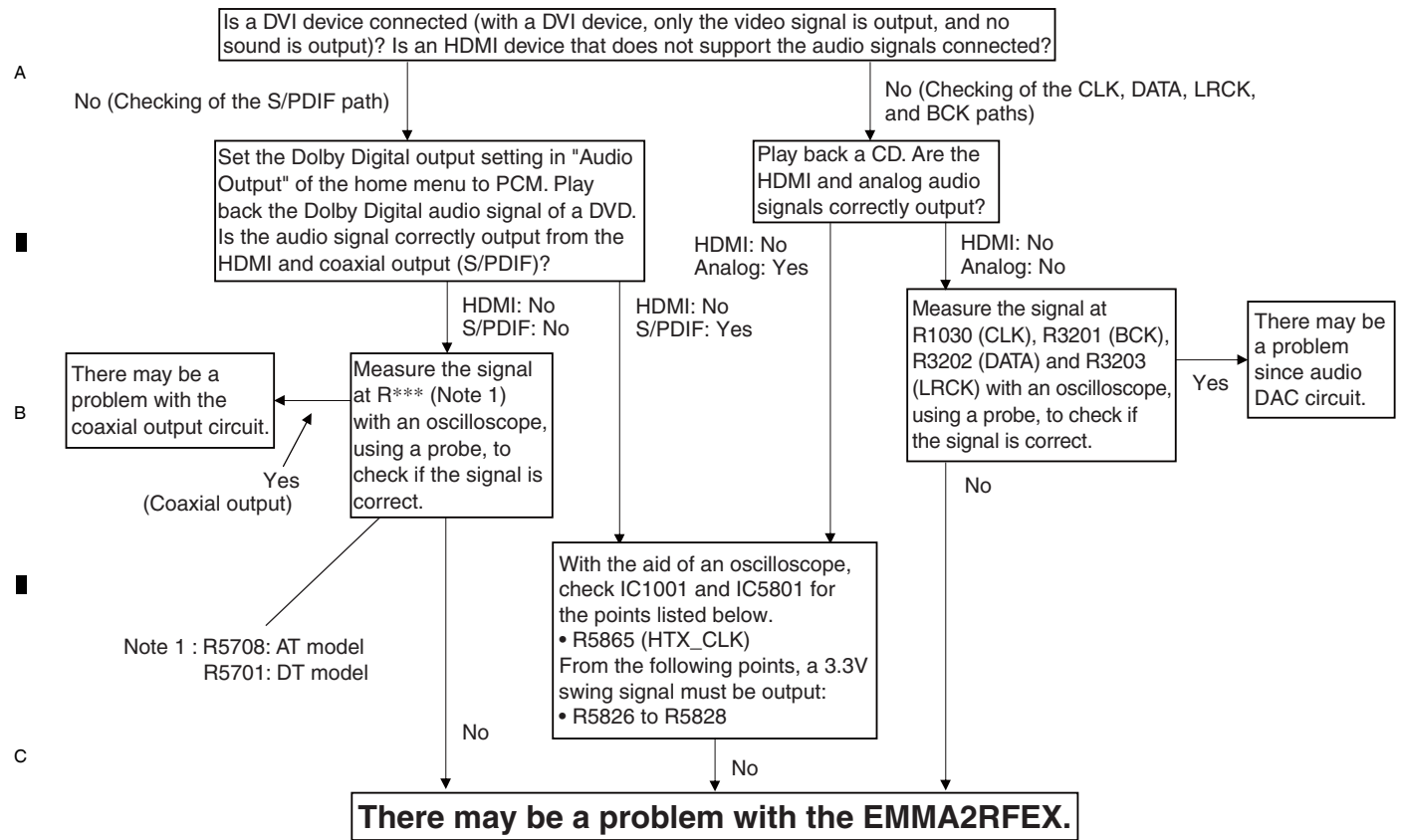

6. SERVICE MODE

◆ Overview and Purposes

To be used to check the status of the product and to collect the information for failure diagnosis.

The following information to be used for servicing is displayed:

- [1] First screen : Version, HDD information, etc.
- [2] Second screen : ATA/ATAPI debug screen (Writer information)
- [4] Fourth screen : VR-recording-related error logs
- [5] Fifth screen : VR-playback-related error logs

Each screen has sublevel screens.

[Note]

After entering any Service mode screen, to shift to another Service mode screen, first quit that Service mode screen then enter another Service mode screen.

◆ SERVICE MODE MAP

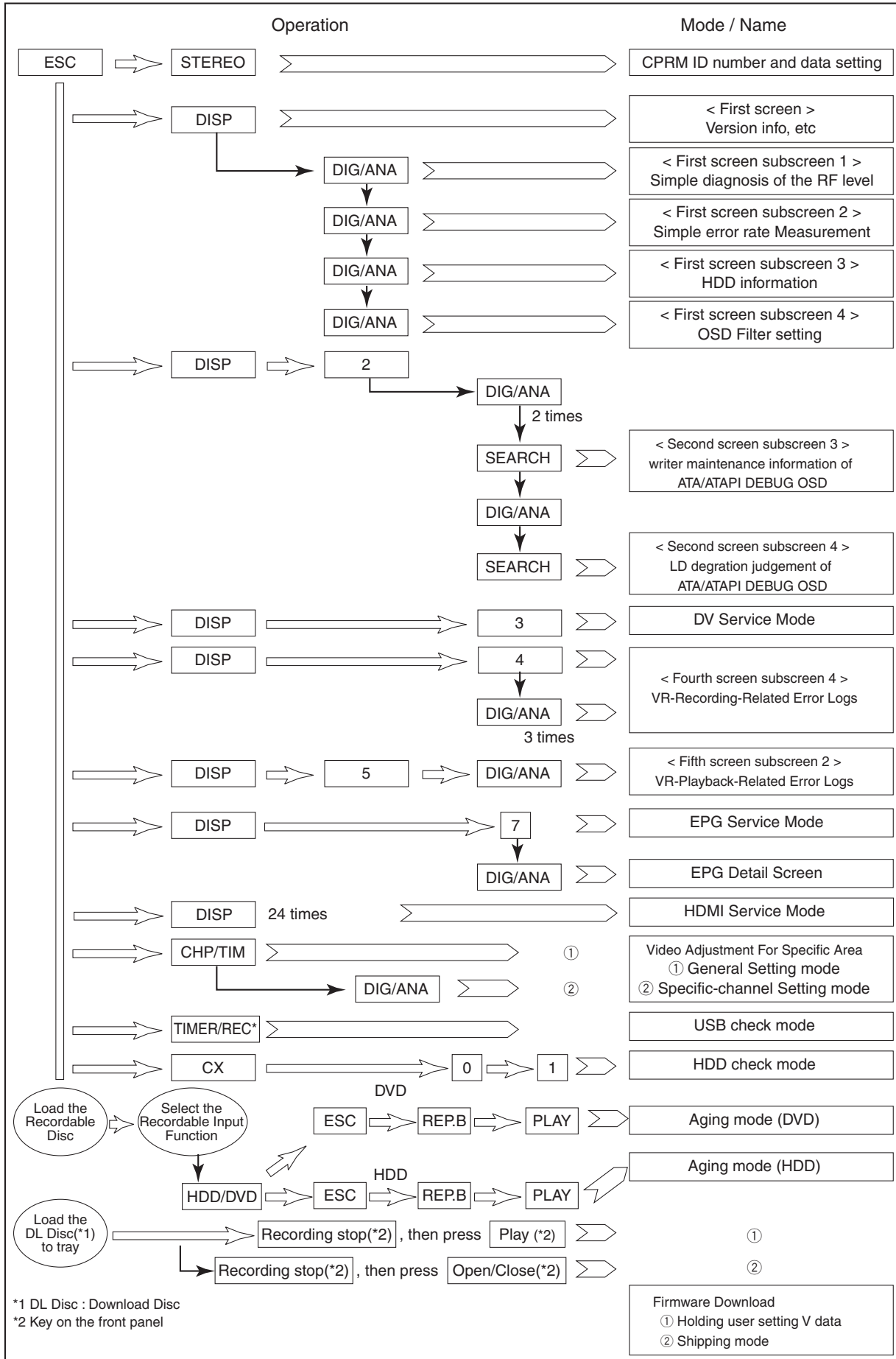

6.1 VERSION INFORMATION, ETC. (FIRST SCREEN)

[Purposes]

To check the versions of the system control computer, TUNER microcomputer, and firmware for the drive, simple measurement of the RF level for the U/V tuner, results of the simple error rate measurement, HDD information, and OSD Filter setting

[Tools to be used]

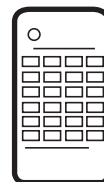

Remote control unit for servicing
(GGF1381)



Aluminum-coated test disc
(GGV1025)

[How to enter] While the GUI screen is not displayed, press the **[ESC]** then **[DISP]** keys.

How to enter and change subscreens of the first screen: While the first screen is displayed, press the **[DIG/ANA]** key repeatedly until your desired subscreen is displayed. The subscreens change cyclically.

[How to quit] Press the **[ESC]** key.

[Description]

(1) First screen

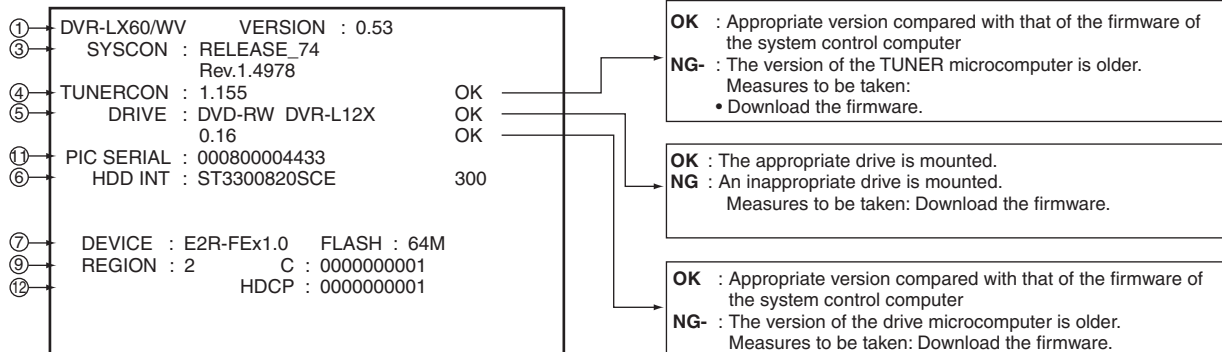

- ① Model name/destination
- ② Version of the recorder software
- ③ Revision No. of the system-control computer software
- ④ Version No. of the tuner microcomputer
Result of the combination check with system u-com
- ⑤ Information on the built-in drive
(Model name, version No., model type)
- ⑥ Data of the built-in HDD, capacity of the HDD
- ⑦ DEVICE information (EMMA type, ES No.)
- ⑧ FLASH ROM information
- ⑨ Region No.
- ⑩ CPRM information (CPRM key No.)
- ⑪ PICUP SERIAL No.
- ⑫ HDCP information (HDMI authentication key)
Same number as that for CPRM.

• Details on HDD data are described below:

HDD : WDC10234564 # 160

Capacity of the HDD (unit: Gbytes)

HDD identification error indication

Name of manufacturer, part No. by manufacturer

If any abnormality exists in HDD connection, the indications shown in Table 1 below are displayed.

Table 1: HDD recognition status represented by the HDD data display

HDD identification conditions	Example of HDD data to be displayed	Remarks
Failure in physical identification of HDD (no connection, defective HDD, interface error)	Blank space	<ul style="list-style-type: none"> Check the connection to the SATA connector. Replace the SATA flexible cable and connector. Replace the HDD. Replace the resistor in the SATA communication line.
Physical identification of HDD possible, but not identified (CPRM ID is not input.)	WDC 10234564 # 160	<ul style="list-style-type: none"> Input the CPRM ID.
Physical identification of HDD possible, HDD identified, but failure in logical formatting	WDC 10234564 ! 160	<ul style="list-style-type: none"> "!" represents an HDD-recognition error. Initialize the HDD or erase all titles.
Physical identification of HDD possible, HDD identified, and correct logical formatting (HDD correctly identified)	WDC 10234564 160	

If an error indication in the HDD data does not disappear even after the above measures were taken, refer to another sheet of "HDD Service Mode."

◆ Simple Diagnosis of the RF Level (Subscreen 1)

[Purposes]

To check the RF signal of the U/V tuner by checking the input frequency difference and AGC voltage in this debug mode

[How to enter]

While the User Setting display is displayed, press the **[ESC]**, **[DISP]**, then **[DIG/ANA]** keys, in that order.

[How to quit]

Press the **[ESC]** key.

[Description]

```

DVR-LX60/WV   VERSION : 0.53
SYSCON  : RELEASE_74
           Rev.1.4978
TUNERCON : 1.155           OK
DRIVE    : DVD-RW DVR-L12X OK
           0.16           OK
PIC SERIAL : 000800004433
HDD INT   : ST3300820SCE   300
  
```

```

DEVICE : E2R-FEx1.0  FLASH : 64M
REGION : 2           C : 0000000001
           HDCP : 0000000001
  
```

```

Input CH : ** ch
Freq Diff : Low 1
AGC Volt  : **** mV
  
```

Input channel
Input frequency difference
AGC voltage

Subscreen 1

1) Frequency Difference (Freq Diff)

How much tuning is off is monitored, as shown below:

Input Frequency	Display	
Faraway	High 7	
High (within 200kHz)	High 1~5	
Just Tune	Center	
Low	within 200kHz	Low 1~5
	over 200kHz	Low 7

2) AGC voltage (AGC Volt)

The gain controlled by the tuner is monitored to infer the input electric field intensity.
(The accuracy of inference differs depending on the product.)

	Field Intensity	AGC VOL
Intense field area (Clear image)	70 dB μ or more	3100 mV or less
Less intense field area (Noise may be generated.)	50 dB μ or more 70 dB μ or less	3100 - 4400mV
Weak field area (Much noise. EPG/VPS/PDC sometimes cannot be obtained.)	30 dB μ or more 50 dB μ or less	4400 mV or more (It is unable to discriminate under the weak field area.)
Very weak field area (Image damaged. EPG/VPS/PDC cannot be obtained.)	30 dB μ or less	4400 mV or more (It is unable to discriminate.)

Tips:

For good reception, the field intensity must be 50 dB μ or more (AGC Volt 4400 mV or less).
For accurate measurement, use a field intensity meter.

◆ Simple Error Rate Measurement (Subscreen 2)

[How to enter]

- While the User Operation screen is displayed, press the **[ESC]** then **[DISP]** keys, then the **[DIG/ANA]** key twice, in that order.
- While subscreen 1 of the first screen is displayed, press the **[DIG/ANA]** key.

[How to quit] Press the **[ESC]** key.

[Measurement procedures]

- ① Display subscreen 2.
- ② Load the Test disc (GGV1025).
- ③ Judge the results of the error rate measurement by referring to Table 1.

ERR RATE : *.*e-*

Subscreen 2

[Tips]

During VR mode playback, the average value of the past 10 VOBUs is displayed. During DVD-Video or Video mode playback, the average value of the past 256 sectors is displayed.
During VR mode playback, the speed ratio of the drive (/: normal, no indication: double speed) is also displayed.

Table 1: Thresholds when determining OK or Error

Disc type	Recording mode	Finalized or not finalized	Reference value
DVD-VIDEO	–	–	8.0×10^{-4}
DVD-R	Video mode	Finalized	1.0×10^{-3}
		Not finalized	1.0×10^{-3}
DVD-RW	Video mode	Finalized	1.0×10^{-3}
		Not finalized	1.0×10^{-3}

◆ HDD Information (Subscreen 3)

- [How to enter]**
- While the User Operation screen is displayed, press the **[ESC]** then **[DISP]** keys, then the **[DIG/ANA]** key three times, in that order.
 - While subscreen 2 of the first screen is displayed, press the **[DIG/ANA]** key.

[How to quit] Press the **[ESC]** key.

[Mode description]

HDD Info
Life Time: 87599h 09m 05s

Cumulative HDD-on time

Subscreen 3

[Tips]

• How the data on cumulative HDD-on time are processed in memory

Storage place:
FLASH ROM

Timing of referring to the data on cumulative HDD-on time:
When the power is turned on, fails, the FLASH ROM is referred to.

Timing of updating the data on cumulative HDD-on time:
While the HDD is on, the data on cumulative HDD-on time in the RAM is updated every 3 seconds, and every time updating is executed the data are stored in the Backup SRAM. When the power is turned off, the data are stored in the FLASH ROM.

• How to clear the data on cumulative HDD-on time

FLASH ROM:

When the HDD Identification Setting is performed, the data on cumulative HDD-on time are automatically cleared. The HDD Identification Setting is automatically performed when the CPRM setting is performed on the CPRM setting screen (to display the CPRM setting screen, press the ESC then the STEREO keys).

- Notes:**
- The data on cumulative HDD-on time are not cleared when resetting to factory-preset values is performed.
 - The data on cumulative HDD-on time are not cleared when the system-control computer software is downloaded.

◆ OSD Filter Setting (Subscreen 4)

[Purpose]

Depending on the monitor used, the character flicker on the OSD may stand out.
If a system, such as character flicker, appears on the monitor, select the filter response.

[Tools to be used]

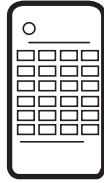

Remote control unit for servicing
(GGF1381)

[How to enter]

- While the User Operation screen is displayed, press the **ESC** then **DISP** keys, then the **DIG/ANA** key four times, in that order.
- While subscreen 3 of the first screen is displayed, press the **DIG/ANA** key.

[How to quit]

Press the **ESC** key.

[Setting procedures]

- ① Display subscreen 4.
- ② Select the setting from the key operation table.

OSD Filter Setting

OSD FILTER : 4

Subscreen 4

[Tips]

As the setting value becomes greater, jitter is reduced on a CRT display. However, as lines for characters appear thick, complex characters may become difficult to read. On the contrary, as the setting value becomes smaller, jitter increases on a CRT display. However, as lines for characters become sharper, complex characters become more legible.

Note: Use the remote control unit for servicing.

Note: A new setting becomes active as soon as it is made. As a new setting is stored in nonvolatile memory, it will be retrieved when the unit is turned on the next time.

Note: After the factory-preset values are downloaded, the setting value for the OSD Filter will be the default value (4).

[(Table 2) Key operation of OSD Filter setting]

Key	Operation	Setting value	Remarks
[Rev x 3], [SPEED+] [x 3 Fwd], [SPEED-]	Changing the setting value for the OSD Filter	0 - 4 (Default value: 4)	[Rev x 3], [SPEED+] : The setting value increases by 1. [x 3 Fwd], [SPEED-] : The setting value decreases by 1.
[CLEAR]	The setting value is reset to default.	-	
[ESC]	To exit the OSD Filter Setting and clear the screen (Appears the tuner screen.)	-	-

6.2 ATA/ATAPI DEBUG SCREEN (SECOND SCREEN)

[Purposes]

To be used as a rough guide to judge whether the pickup unit is all right or not

- Dirt on the pickup lens
- Degradation of the laser diodes for reading CDs and reading/writing to/from DVDs

[Tools to be used]



Remote control unit for servicing (GGF1381)



Aluminum-coated test disc (GGV1025)

[How to enter]

- While the User Operation display is displayed, press the **[ESC]**, **[DISP]**, then **[2]** keys, in that order.
- While any subscreen of the second screen is displayed, press the **[DIG/ANA]** key repeatedly. The subscreens change cyclically.

[How to quit] Press the **[ESC]** key.

◆ Writer Maintenance Information of ATA/ATAPI DEBUG OSD (Subscreen 3)

[How to enter] • While the User Operation screen is displayed, press the **[ESC]**, **[DISP]** then **[2]** keys, then the **[DIG/ANA]** key twice, in that order.

[How to quit] Press the **[ESC]** key.

[Procedures] Update the display by pressing the **[SEARCH]** key while subscreen 3 is displayed.

	ATA / ATAPI	Writer MaintenanceInfo	
①	Power ON	00 00 00 0000 00000000;	Error log for the Writer (Not for Service)
	0102:56	01 00 00 0000 00000000;	
	DVD	02 00 00 0000 00000000;	
②	R0053:48	03 00 00 0000 00000000;	
③	W0022:16	04 00 00 0000 00000000;	
	CD	05 00 00 0000 00000000;	① Power-on time/cumulative power-on time
④	R0034:04	06 00 00 0000 00000000;	② Duration of emission of the laser diode (LD) for DVD-R/DVD while reading
⑤	W0000:00	07 00 00 0000 00000000;	③ Duration of emission of the LD for DVD-W/DVD while writing
		00-00	④ Duration of emission of the LD for CD-R/CD while reading
			⑤ Duration of emission of the LD for CD-W/CD while writing (This function is not used for this model.)

- ② If the total hours of duration of emission of the laser diode (LD) for DVDs while reading ② and that of emission of the LD for DVDs while writing ③ exceed 4,700 hours, the LDs may be degraded. Perform an LD degradation judgment, using subscreen 4.

[Tips]

MTTF hours for each LD
 DVD: 4,700 hours
 CD: 11,000 hours

The ATA/ATAPI Writer Maintenance Info is obtained each time the power is turned on. Thereafter, the data on the subscreen is updated each time the **[SEARCH]** key is pressed (the updating command is sent) while this subscreen is displayed. Care must be taken when updating this subscreen, because an undesired command is inserted if it is executed while recording, etc.

[Note on lighting time data for each LD]

Since data on lighting time of each laser diode (LD) are stored in the flash ROM on the MAIN Assy, after the MAIN Assy is replaced, the data will be cleared. However, after the LOADER Assy is replaced, data on lighting time of each LD will be retained in the MAIN Assy. Therefore, before either the MAIN Assy or LOADER Assy is to be replaced, it is recommended that you write down the lighting time data.

◆ LD Degradation Judgment of ATA/ATAPI DEBUG OSD (Subscreen 4)

[How to enter] • While the User Operation screen is displayed, press the **[ESC]**, **[DISP]** then **[2]** keys, then the **[DIG/ANA]** key three times, in that order.

[How to quit] Press the **[ESC]** key.

[Notes]

- For correct measurement of items ① to ④ indicated in the display below, leave the unit at room temperature (25°C) for a while before turning it on, and do not load a disc.
- For RF measurement (item ⑤), it is recommended to use the Test disc (GGV1025). As the RF level differs depending on the characteristics of the pickup from product to product, it cannot be used for judging degradation of the LD. Use the RF level as a rough guide to know the difference between before and after lens cleaning.

[Procedures] To update the value for each item, press the **[SEARCH]** key while subscreen 4 is displayed. For details on each item and the conditions of updating the values, see Table 2 below.

ATA / ATAPI - LD Degrade			
①	CD	:0070 104%	OK
②	DVD	:0068 96%	OK
③	TMP	:00A3 41 °C	
④	ADJ	:0067 26 °C	
⑤	RF	:3D70	
⑥	TLT	:FFD5	

Table 2: Description of each item and conditions for updating data

No.	Item	Description	Conditions for updating by pressing the SEARCH key
①	CD	Degradation judgment of LD for CD. Regarded as NG when the value is 120% or higher (same standard as for the PC drive)	No disc inserted in the disc tray
②	DVD	Degradation judgment of LD for DVD. Regarded as NG when the value is 120% or higher (same standard as for the PC drive)	No disc inserted in the disc tray
③	TMP	Current temperature inside the Writer	No disc inserted in the disc tray
④	ADJ	Temperature (approx. 25°C) inside the Writer during adjustment	No disc inserted in the disc tray
⑤	RF	RF level (16-bit data, proportional calculation performed using the actual RF level value with 2.5 V = 0xFFFF as the maximum value, displayed in 4-digit hexadecimal)	During playback of disc medium (GGV1025)
⑥	TLT	Writer adjustment data for straight (non-HDD) model (FFFF is displayed when the writer is not adjusted.)	No condition

If the results of degradation of the LDs for CDs or DVDs are NG, replace the drive.

6.3 VR-RECORDING-RELATED ERROR LOGS (FOURTH SCREEN)

[Purposes]

To roughly determine in which category shown below a symptom that is difficult to reproduce belongs.
For details on the categories of error logs displayed, see "Table 1: Description of VR-recording-related errors."

- Errors related to the MPEG Encoder
- Errors related to the drive system
- Errors related to copying
- Errors related to others
- Errors related to the HDD

[Tool to be used]

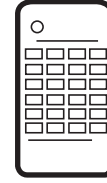

Remote control unit for servicing
(GGF1381)

[How to enter]

- While the User Operation display is displayed, press the **[ESC]**, **[DISP]**, then **[4]** keys, in that order.
- While any subscreen of the fourth screen is displayed, press the **[DIG/ANA]** key repeatedly.
The subscreens change cyclically.

[How to quit] Press the **[ESC]** key.

[Description of each subscreen]

(1) VR-Recording-Related Error Logs (Subscreen 1)

- Errors related to recording are displayed on the lines "Rec Err:," as shown below.
For details on errors, see "Table 1: Description of VR-recording-related errors."

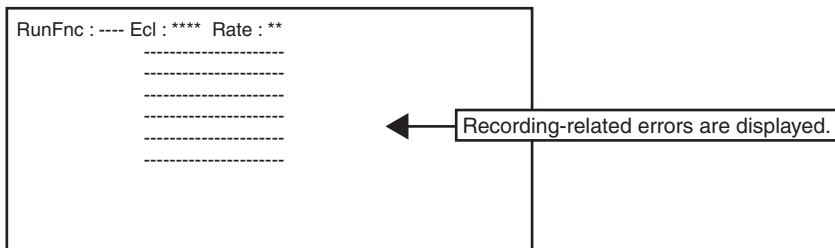

(2) Subscreen 2 and 3 (These subscreens are not for service use.)

(3) VR-Recording-Related Error Logs (Subscreen 4)

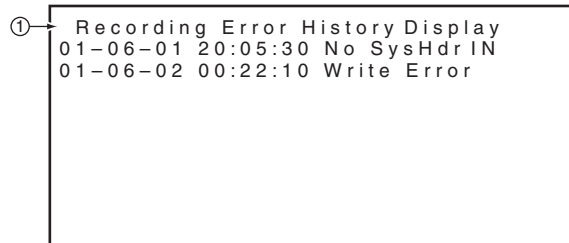

- ① There are two error-log screens, on which up to 9 logs per screen are displayed.
(generation time [year-month-day, hour:minute:second], error data in simplified description)

[Tips]

- The two error-log screens can be switched by pressing the **[SPEED+]** or **[SPEED-]** key.
- For details on error messages, see Table 1 "Description of VR-recording-related errors".

(4) Subscreen 5 to 12 (These subscreens are not for service use.)

◆ Description of VR-Recording-Related Errors

Any error message marked with * is displayed "RecErr : -----" on the Subscreen 1 of the fourth screen.

● Error Related to MPEG Encoder

Error Message	Description
AVEnc Hang	AVEncoder failed
IN Encode *	Changes cannot be made in the process of encoding
No SysHdr IN	System packet is not input periodically
Stm Start NG	Failure to start encoding (reasons not clear)
Stream NG	Inappropriate input stream data
Strm Start NG	Timeout waiting for system packet input at the beginning

● Error Related to Drive System

In a case of an error in the drive system, scratches or dirt on a disc, or a problem of the drive itself (dirty pickup) may be suspected.

Error Message	Description
Bdr Cls NG	Close Border failed
Bdr Opn NG	Open Border failed
BUF Overflow	Overflow of the Stream Buffer
CLS Rzon Fail	Video Mode Close Rzone failure
Drive Hang	The Drive is hung up.
Drv Err	General error of the drive
Drv Hard Err	Abnormality in the drive hardware or firmware
Drv TimeOut	Timeout waiting for drive operation
Fail Repair	Repair failed
Format NG	Format failed
May Be V mode	Although TMP_VMGI is not written, it may be Video Mode disc.
Mech No Res	No response from the mechanical-control computer
MKB Invalid	MKB reading error
NWA Exhaust	NWA surpassed and impossible to use
OPC NG	OPC failed
PCA Full	PCA has been used up.
Read Err	Reading failed, ECC failed, etc.
ReadOnly DISC *	Because some data are invalid, data cannot be written
RMA Full	RMA has been used up.
Rzn Cls NG	Close RZone failed
Rzn Rpr NG	Repair RZone failed
Rzn Rsv NG	Reserve RZone failed
TMP-VMG WrErr	Video Mode TMP VMGI Write Error
VTSI_B Wr Err	Video Mode VTSI BUP Write Error
VTSI_B2 Wr Err	Video Mode VTSI BUP Write Error (After Layer Change)
VTSI Wr Err	Video Mode VTSI Write Error
VTSI2 Wr Err	Video Mode VTSI Write Error (After Layer Change)
Write Err	The Drive failed to write and could not be recovered.
May Be PVR	May be +VR disc, but no RSAT
V Final fail	Abnormal process occurred when finalizing Video mode
DLVR trace NG	Close Rzone failed at dual layer disc

RSAT : Reserved Space Allocation Table

● Error Related to Dubbing

Error Message	Description
H2D CP SomeNG	Other NG HDD →DVD copy
Mem get NG	Video Mode Copy Memory has not ensured.
Strm TransfNG	Video Mode Copy Stream Transfer NG
Tracon Trn NG	Video Mode Copy Tracon transfer has not been completed.
VC Cell Max	Maximum number for Video Mode copy Cells exceeded
VC CopyCancel	Video Mode Copy Copy Cancel
VC FlushC NG	Video Mode Copy Flush Cache NG
VC HDD C Err	Obtaining Video Mode Copy HDD Cell information failed
VC HDD Inf NG	No information on Video Mode Copy HDD
VC HDD Info NG	Format failed
VC Idling NG	Video Mode Copy idling NG
VC Pck Ani NG	Analyzing Video Mode Copy Pack failed

● Error Related to Dubbing (Continued)

Error Message	Description
VC Transf Stp	Video Mode Copy Transfer Stop
VC TSO BLK NG	Video Mode Copy TSO Block transfer has not been completed.
VC VOBu SizeE	Video Mode Copy VOBu Size NG
V Rsv RzoneNG	Video Mode Copy Reserve Rzone failed
V2H APP FL NG	VR →HDD APP FLG is OFF
V2H Aud Ch NG	VR →HDD Audio Channel NG
V2H Aud Md NG	VR →HDD Audio Mode NG
V2H Aud Strm N	VR →HDD Audio Stream number NG
V2H SRC Prot	VR →HDD copy prohibited material
V2H Unknown	VR →HDD other NG
V2H VOBu TMNG	VR →HDD Play back time of each VOBu is different
V2H V Reso NG	VR →HDD Video resolution NG
H2D CP NoSpac	HDD →DVD insufficient free space for copy
H2D TO HDDRD	HDD →DVD (VR) TimeOut at HDD playing side
H2D TO SPRO	HDD →DVD (VR) TimeOut at internal processing
H2D TO DVDWR	HDD →DVD (VR) TimeOut at HDD recording side

● Other Errors

Error Message	Description
Abort *	Cancellation
Already open	Extension file is already opened.
BK BATT Down	Backup RAM data has been erased.
BK FSYS Dirty	Backup RAM data has not been written on the File Sys.
BUG	Some bugs
BusReset Done	Bus Reset has been executed.
Cell Close NG	Cell Close NG
CPRM IC NG	Inappropriate CPRM IC
Dir Depth Err	Tree of Directory is too deep.
Disc Full	No further data can be written because the disc is full.
DRAM CLR Err	Video Mode DRAM (Stream Buffer) Clear failure
DRAM NG	Abnormality in access to the Work DRAM
Drive Destroy	The drive has crashed.
EncModul Hang	Encoder routine is hung up.
F Alrdy Exst	Extension file is already exist.
File cancel	Extension file is canceled.
FileNot Exist	Extension file is not exist.
Format Excec	Formatting has been executed.
Invalid Disc *	The disc cannot be recognized.
Invalid Param *	Invalid parameter
Invalid TMVMG	Invalid TMP_VMG1 content
Invalid UDF *	Invalid UDF content
Invalid VMG *	Invalid VMG content
Invalid VTSl	VTSl information of +VR is unusual.
Irr Action *	Incorrect action
MKB REVOKED	Error in gaining data
Limit Over *	Standard maximum limit exceeded
No More Info *	No more space in the internal work-management area
No Permission *	No permission to write to the disc
No Video	No video input (not locked)
Now Busy *	In the process of the emergency processing
NV Pck DMA Er	Inappropriate NaviPack DMA
NV Pck MK Err	Error in creating NaviPack
Ourob Strm NG	Inappropriate stream data to the Ouroboros input
Over Heat	Abnormal temperature
PARAM NO ACCP	Recording parameter is not matched.
Process Over	Process is overfull.
Protect Src *	Source to be recorded is copy-protected.
Rec Pause *	No operation permitted during recording pause
Relocation Do	VR-recording data was relocated

● Other Errors (continued)

Error Message	Description
Repair Excec	Repairing has been executed.
Something *	Undetermined error
SRAM NG	Abnormality in access to the backup work SRAM
Status NG *	Abnormality in change of statuses
SW PVR	Switch to +VR playback process
SW Vpb mode *	Switching to video playback routine is required.
SW Vrec mode *	Switching to video recording routine is required.
Unmatch Stamp *	Impossible to modify because of nonmatching time stamp
VBR-SRAM NG	Abnormality in VBR SRAM
V Categ ID NG	Inappropriate Category ID
V Cate Inf NG	Inappropriate Category information
V Ext MAX Ovr	Count Max exceeded
V ExtToo Big	The extension file is too large.
V Ext TY NG	Type NG
Virgin DISC	Virgin Disc
VOBU Info NG	Inappropriate VOB information
WaterMark Det	Watermark detected
WM Cracked	WM Cracked
Param Short	Editing Error (Clear A-B)
Invalid VRMI	Information of +VR is NG. (VRMI)

● Error Related to HDD

Error Message	Description
Do nothing	Do nothing for demand.
ESFSYS CORUPT	easyfsys error
ESFSYS INIT	easyfsys initializing
HDD Buff High	High-level process executed for the HDD Buffer
HDD DEF DONE	HDD deflag finished
HDD DEF ERR	HDD deflag error
HDD Destroy	HDD is not recognized on the bus.
HDD INFO BAD	Incorrect HDD Management Data
HDD Initialize	HDD initialized
HDD IRRG POFF	Abnormal power off
HDD MBR NG	Inconsistent MBR data
HDDReset Done	HDD Reset executed
HDD ROMSUM NG	Rom-code check sum NG
HDD SIG NG	Inconsistent HDD Management Data Magic
HDD SMART NG	Inappropriate HDD SMART
HDD Trans Err	DMA error in HDD copy transfer
HDD unauthor	Inconsistent HDD serial No.
HDD Zero WR	MBR was witten
Task No Activ	Task has not been activated.
TT Rec Over	Title recording time full
HDD WRONG TGT	Invalid HDD target No. is directed.
extHDD Ignore	External HDD is dismounted.
HDD PFile NG	Program file installed in HDD is NG.
HDD DEL TT	Delete the title by HDD recovery.
HDD DEL PL	Delete the dubbing list by HDD recovery.
HDD DEL OC TT	Delete the title moving on the way inside HDD

● No Error

Error Message	Description
Non Err *	Normal

Abbreviations:

ECC = 4 byte Code for Error Correction
 UDF = Universal Disc Format
 PCA = Power Calibration Area
 OPC = Optical Power Control
 NWA = Next Writable Address

VMG = Video Manager
 RMA = Recording Management Area
 MKB = Media Key Block
 TMP_VMGI = Temporary Video Manager Information
 Border = from Lead-in to Lead-out

6.4 VR-PLAYBACK-RELATED ERROR LOGS (FIFTH SCREEN)

[Purposes]

It can be inferred that an operation that caused an error in the drive was performed or that a failure occurred in the drive if any of the error logs shown in "Table 2: Description of VR-playback-related errors" is recorded on this screen.

[Tool to be used]

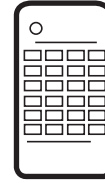

Remote control unit for servicing
(GGF1381)

[How to enter]

- While the User Operation display is displayed, press the **[ESC]**, **[DISP]**, then **[5]** keys, in that order.
- While any subscreen of the fifth screen is displayed, press the **[DIG/ANA]** key repeatedly. The subscreens change cyclically.

[How to quit] Press the **[ESC]** key.

[Description of each subscreen]

(1) Subscreen 1 (This subscreen is not for service use.)

(2) VR-Playback Error Logs (Subscreen 2)

- For details on error messages, see Table 2 "Description of VR-playback-related errors".
- If a VR-playback-related error is generated, a problem in data reading from the disc may be suspected. (The possibility of a problem on the drive side is high.)

①	G:001-01 00h00m00s00	00000000
	Error=[00000000]	
	h m s f Name Line Message	
②	G001-01:00000001	ChgSta 01676 WaiPau Err
	L002-01 :00123002	ComInf 00669 DecHdl(14)
	L002-01 :00410303	ComInf 00669 DecHdl(40)
	G004-01:00000004	ChgSta 01676 WaiPau Err

- ① Information on display position
 Original / Play list (G/L), Title No., Chapter No. [X:XXX-XX]
 Display time (hour, minute, second & frame) [XXhXXmXXsXX]
 Logic address for playback (ID) [XXXXXXXXX]
 Number of entries to error log [XXXXXXXXX]
- ② Error message log
 Original / Play list (G/L), Title No., Time of occurrence (min & sec) [XXX:XXXX]
 Location of occurrence (this data is used for development), Name: Name of module where the error occurred, Line: Number of line where error occurred
 Playback-system errors that occurred in 13 times of playback in past [XXX:XXXXXXXX]
 * For details of error information, refer to the Appendix Table 1.
 * If information on errors which occurred on days earlier than the current day is contained on the screen, the information that follows the information which are displayed with "^" between "Time of occurrence", "Name", "Line" and "Message" indicates the errors that occurred on the current day.

◆ Description of VR-Playback-Related Errors

Error Message	Details of error
AudioPB Err	Audio initialization error
WaiPau Err	Pause was disabled though tried. (Pause-wait timeout)
CC_OS_ERR	CC output processing error
Tr:NullBlk	No valid data in the first block
Tr:NaviErr	Navigation pack error
Tr:ReadErr	Data read error
Dec:PicDisp	Not played up to final PTS
Dec:Size	horizontal/vertical_size in sequence header is 0 or above 720 x 576.
Dec:PicTyp	picture_coding_type in picture header is neither of the I, P, nor B picture type.
Dec:Struct	picture_structure in picture coding extension is neither top/bottom_field or frame picture.
Dec:Syntax	Header size is insufficient or does not match with markerbit.
Dec:NoHead	No picture header exists between picture data.
Dec:SqErr	Detected sequence_error_code.
Dec:Refrenc	In Field structure, top_field and bottom_field of temporal_reference in picture header does not match.
Dec:Profile	profile_and_level_indication in sequence extension header is exceeding MP@ML.
DecHdl(**)	<p>Decoder command execution timeout. (**) is replaced by No. of command which was to be executed. The Nos. and names of commands are as follows.</p> <pre> /* DECODER system command */ 0 HANDLER_DECODER_INIT, 1 HANDLER_DECODER_INIT_STARTUP, 2 HANDLER_DECODER_INIT_PLAY, 3 HANDLER_DECODER_INIT_RTR_PLAY, 4 HANDLER_DECODER_INIT_AUDIO, 5 HANDLER_DECODER_EXIT, 6 HANDLER_DECODER_BLACK_BACK, 7 HANDLER_DECODER_SET_DISP_FMT, 8 HANDLER_DECODER_SET_ASPECT_MODE, 9 HANDLER_DECODER_DISP_BITRATE, /* DVD command */ 10 HANDLER_DEC_DVD_VIDEO_PLAY, 11 HANDLER_DEC_DVD_VIDEO_PLAY_LIST, 12 HANDLER_DEC_DVD_AUDIO_PLAY, 13 HANDLER_DEC_DVD_STOP, 14 HANDLER_DEC_DVD_PAUSE, 15 HANDLER_DEC_DVD_PAUSE_STILL_MODE, 16 HANDLER_DEC_DVD_STEP, 17 HANDLER_DEC_DVD_REWSTEP, 18 HANDLER_DEC_DVD_PAUSE_OFF, 19 HANDLER_DEC_DVD_FF, 20 HANDLER_DEC_DVD_REW, 21 HANDLER_DEC_DVD_SLOW, 22 HANDLER_DEC_DVD_REWSLOW, 23 HANDLER_DEC_DVD_SCAN_OFF, 24 HANDLER_DEC_DVD_SLOW_OFF, 25 HANDLER_DEC_DVD_REWSLOW_OFF, 26 HANDLER_DEC_DVD_REWSKIP_TO_REWSLOW, 27 HANDLER_DEC_DVD_REWPAUSE, 28 HANDLER_DEC_DVD_PLAY_LIST_END_CHECK, 29 HANDLER_DEC_DVD_SET_CAPTION_SW_OFF, 30 HANDLER_DEC_DVD_SET_CAPTION_SW_ON, 31 HANDLER_DEC_DVD_REWPAUSE_TO_REWSLOW, </pre>

Error Message	Details of error
A	<pre> 32 HANDLER_DEC_DVD_REGIST_TRICK_CALLBACK, 33 HANDLER_DEC_DVD_TRICK_DATA_END, 34 HANDLER_DEC_DVD_AUDIO_STOP, /* management information */ 35 HANDLER_DEC_INIT_NV_PCK, 36 HANDLER_DEC_INIT_RDI_PCK, 37 HANDLER_DEC_READ_NV_PCK_POINT, 38 HANDLER_DEC_READ_RDI_PCK_POINT, 39 HANDLER_DEC_READ_STC, 40 HANDLER_DEC_READ_PTS, 41 HANDLER_DEC_HLI_ENABLE, 42 HANDLER_DEC_COMMAND_PLAY, 43 HANDLER_DEC_COMMAND_PAUSE, 44 HANDLER_DEC_COMMAND_RSLOW_VOBU_STOP, 45 HANDLER_DEC_INIT_VIDEO_MODE, 46 HANDLER_DEC_SET_VIDEO_MODE, 47 HANDLER_DEC_CHECK_VIDEO_OUTPUT, 48 HANDLER_DEC_CHECK_VIDEO_ERROR, 49 HANDLER_DEC_DISPLAY_SUBPICTURE, 50 HANDLER_DEC_SET_SUBPICTURE_PALLET, 51 HANDLER_DEC_IPB_REVERSE, 52 HANDLER_DEC_SET_AUDIO_SYNC, 53 HANDLER_DEC_COMPULSION_OUTPUT_SUBPICTURE, 54 HANDLER_DEC_CLEAR_LAST_NV_PCK_POINT, 55 HANDLER_DEC_CLEAR_LAST_RDI_PCK_POINT, 56 HANDLER_DEC_GET_PICTURE_PARAM, 57 HANDLER_DEC_CHECK_BUFFER_EMPTY, 58 HANDLER_DEC_CHECK_TRICK_END, 59 HANDLER_DEC_READ_VCD_PTS, /* still picture */ 60 HANDLER_DEC_DVD_STILL_NOTIFY, 61 HANDLER_DEC_DVD_STILL_PLAY, 62 HANDLER_DEC_DVD_STILL_FF, 63 HANDLER_DEC_DVD_STILL_FF_OFF, 64 HANDLER_DEC_DVD_STILL_SLOW, 65 HANDLER_DEC_DVD_STILL_SLOW_OFF, 66 HANDLER_DEC_DVD_STILL_PAUSE, 67 HANDLER_DEC_DVD_STILL_PAUSE_OFF, 68 HANDLER_DEC_DVD_STILL_DATA, 69 HANDLER_DEC_DVD_STILL_GET_COUNT, 70 HANDLER_DEC_DVD_RDI_NOTIFY, /* closed caption */ 71 HANDLER_DEC_CAPTION_NOTIFY, 72 HANDLER_DEC_CAPTION_BUFFER_RESET, 73 HANDLER_DEC_CAPTION_SET_INPUT_USER_DATA, 74 HANDLER_DEC_CAPTION_SET_INPUT_FRAME_DATA, 75 HANDLER_DEC_CAPTION_SEND_FRAME_DATA, 76 HANDLER_DEC_FRAME_CHANGE_NOTIFY </pre>
B	
C	
D	
E	
F	

6.5 DV SERVICE MODE

◆ DV Debug

[Purpose]

To check whether communication between a DV device and the unit is normal when a DV device is connected

[Tools to be used]



Remote control unit for servicing (GGF1381)

- DV device
- DV cable

[How to enter] Press the **[ESC]**, **[DISP]** then **[3]** keys, in that order.

[How to quit] Press the **[ESC]** key.

[Mode description]

```

① → (DV/1394) Init:OK AV:02 DV:01
② → [Recorder] GUID:00E0360006100001 IRM
③ → iPCR:C03F0000
④ → [DV]   GUID:0080880303480E96
⑤ → VN:VICTOR MN:GR-D50K
⑥ → TM:C3 TS:75 CT:32 WP:01 PS:FF OS:00
⑦ → CA:A000002020 MD:VTR
⑧ → [DVdecode:Yes]           LineSys:525-60
⑨ → TC:00h20m35s   RD:02/02/05 RT:10h34m50s
⑩ → ASPECT:4:3     CGMS:000000 APSTB:00 DEC:525-60
⑪ → SF:32KHz QU:12bit AMODE:4) Stereo
    
```

Boldface alphanumerics : Fixed indications
 Nonboldface alphanumerics : Variable indications

No.	Item	Description	Remarks
	Init	Whether the initialization of 1394 LINK and DV decoder inside EMMA2RFEX has been completed (OK) or not (NG)	
①	AV	Number of AV devices recognizing connection	Identification number of AV devices including D-VHS, Digital Tuner, etc other than DV devices.
	DV	Number of DV devices recognizing connection	If the number does not become 01 even if a DV device is connected, identification of that device fails.
②	GUID	GUID set in ConfigROM of the unit	GUID : Global Unique ID (Specific ID for DV devices) If the unit is ROOT (IRM), IRM is displayed at the side position of GUID display.

No.	Item	Description	Remarks
③	iPCR	iPCR value of the unit	
④	GUID	GUID set in ConfigROM of the connected DV device	Data are displayed only if one DV device is identified. If the connectd DV device is ROOT (IRM), IRM is displayed at the side position of GUID display.
⑤	VN	Vendor name set in ConfigROM of the connected DV device	Data are displayed only if one DV device is identified. (Depending on the device, the vendor name may not be set in ConfigROM.)
	MN	Model name set in ConfigROM of the connected DV device	Data are displayed only if one DV device is identified. (Depending on the device, the model name may not be set in ConfigROM.)
⑥	TM	Transport Mode data obtained from the DV device	Data are displayed only if one DV device is identified.
	TS	Transport State data obtained from the DV device	
	CT	Cassette Type data obtained from the DV device	
	WP	Write-protection data obtained from the DV device	
	PS	Power-state data obtained from the DV device	
	OS	Output signal mode data obtained from the DV device	
⑦	CA	Connect AV data obtained from the DV device	Data are displayed only if one DV device is identified.
	MD	DV device mode	Camera or VTR is displayed only if one DV device is identified.
⑧	[DVdecode:XXX]	Whether Yes (in the process of requesting DV input) or No is indicated in XXX	Normally, Yes is indicated only when CH is set to DV.
	LineSys	Input Line System setting	
⑨	TC	Time-code data of the DVdecode Stream, or response data of the Time Code command	Stream time-code data are obtained when the tape is played in forward direction. Otherwise, time-code data are obtained through an AV/C command.
	RD	Rec Date of DVdecode Stream	
	RT	Rec Time of DVdecode Stream	
⑩	ASPECT	Aspect Ratio of DVdecode Stream	
	CGMS	CGMS of DVdecode Stream (from left to right, CGMS data of bits 5-4: Audio ch 2, bits 3-2: Audio ch 1, and bits 1-0: Video)	*CGMS (Copy Generation Management System): The two-digit codes added to broadcast programs represent the following: 00: Copy freely, 10: Once copy, 11: Never copy
	APSTB	APS trigger bit of DVdecode stream	
	DEC	With/without DVdecode stream input	With input: Signal type (525-60, 625-50, 1125-60, 1250-50, or Invalid) is indicated, Without input: "No" is indicated.
⑪	SF	Sampling Frequency of DVdecode Stream	If SF is 44 kHz, it is considered that 44.1-kHz audio is input, and sound is muted on the unit.
	QU	QUANTIZATION of DVdecode Stream	
	AMODE	AUDIO MODE of DVdecode Stream	

◆ Simple Diagnosis of DV

Symptoms	Location in the Debug Screen	Items to be Checked, and Conditions	Possible causes
No operation for DV input	DV ①	Check the initDV indication: OK: Initialization of 1394 LINK and DV decoder inside EMMA2RFEX appropriately completed. NG: Initialization of 1394 LINK and DV decoder inside EMMA2RFEX has not been completed properly.	Defective IC1001(EMMA2RFEX)/IC5103(1394PHY), improper connection between IC1001 / IC5103, defective soldering, defective power supply, etc.
	DV ①	Check the number of DV devices when one DV device is connected to the recorder: 01 : The connected DV device is correctly identified. Other than 01 : The connected DV device is not correctly identified.	Defective DV terminals, improper connection of the DV-terminal board, defective IC5103(1394PHY), defective cables, an IEEE 1394 device other than the DV device connected.
No picture nor sound for DV input	DV ⑥	Check of DV decoding when the recorder channel is set to DV: Yes: The recorder is in the process of a DV input operation No: The recorder is not executing a DV input operation	Defective IC1001(EMMA2RFEX), defective soldering, defective power supply, etc.
	DV ⑩	Check DEC: 525-60: An NTSC DV signal is input from the DV device. 625-50: A PAL DV signal is input from the DV device. No: No DV signal is input from the DV device.	Defective DV terminals, improper connection of the DV-terminal board, defective source device defective IC1001(EMMA2RFEX), IC5103(1394PHY) Note: As to a model having the Input Line System setting, if the setting and the actual input signal system do not match, no picture appears.
DV input recording impossible	DV ⑩	Check CGMS:	Recording cannot be performed for a copy-protected source.
No sound for DV input	DV ⑪	Check SF: 32 khz: An audio signal with 32-kHz sampling frequency is being input. 48 khz: An audio signal with 48-kHz sampling frequency is being input. 44 khz: An audio signal with 44.1-kHz sampling frequency is being input.	An audio signal with 44.1-kHz sampling frequency is muted.

6.6 EPG SERVICE MODE

[Purposes]

Reasons for the following malfunctions can be inferred by checking the conditions for obtaining the past EPG data:

- ① EPG data cannot be obtained.
- ② Some EPG data obtained are missing.

[Tool to be used]

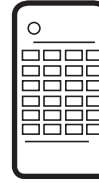

Remote control unit for servicing (GGF1381)

[How to enter] • Press the **[ESC]**, **[DISP]**, **[7]** keys, in that order.

[How to quit] Press the **[ESC]** key.

[Description of the mode]

1. Summary screen

```

0          1          2          3          4
01234567890123456789012345678901234567
00 (EPG EURO)
01 Next Data Download Time : 14:00
02           Duration       : 01h30m
03 Gemster Data Fail Count : 00
04
05
06
07 EPG Data Receive Err Summary
08 Date Start End MD CH RcvPkt TotalErr
09 03/31 13:00 13:30 DL 03 001853 000000
10 03/31 09:00 11:00 DL 03 001192 000000
11 03/31 08:00 08:05 HS -- 000645 000000
12 03/31 00:00 00:00      000000 000000
13 03/31 00:00 00:00      000000 000000
14 03/31 00:00 00:00      000000 000000
    
```

Lines 01-02	The next download starting time for the EPG data is displayed. Next Data Download Time: Starting time Duration: Duration required for acquiring the EPG data														
Lines 03	The Gemster EPG data cannot be found. Number times of Host Scan and Schedule Download, DT models only (Always 00 except DT model)														
Lines 09-14	The 6 latest error logs when EPG data were received are displayed, with the latest one at the top. <table border="1" style="width: 100%;"> <tr> <td>Date</td> <td>: Month/day when reception started</td> </tr> <tr> <td>Start</td> <td>: Time when reception started</td> </tr> <tr> <td>End</td> <td>: Time when reception ended</td> </tr> <tr> <td>MD</td> <td>: Method for acquiring the EPG data (HS: Host scanning process, DL: Downloading process of the EPG data)</td> </tr> <tr> <td>CH</td> <td>: Data-receiving channel</td> </tr> <tr> <td>RcvPkt</td> <td>: Total number of received packages. A number 999,999 or greater is displayed as "999999."</td> </tr> <tr> <td>Total Err</td> <td>: Total errors during reception. The sum of Hamming Err, Trans Err and InvLine Err numbers indicated on the Detail screen. A number 999,999 or greater is displayed as "999999."</td> </tr> </table>	Date	: Month/day when reception started	Start	: Time when reception started	End	: Time when reception ended	MD	: Method for acquiring the EPG data (HS: Host scanning process, DL: Downloading process of the EPG data)	CH	: Data-receiving channel	RcvPkt	: Total number of received packages. A number 999,999 or greater is displayed as "999999."	Total Err	: Total errors during reception. The sum of Hamming Err, Trans Err and InvLine Err numbers indicated on the Detail screen. A number 999,999 or greater is displayed as "999999."
Date	: Month/day when reception started														
Start	: Time when reception started														
End	: Time when reception ended														
MD	: Method for acquiring the EPG data (HS: Host scanning process, DL: Downloading process of the EPG data)														
CH	: Data-receiving channel														
RcvPkt	: Total number of received packages. A number 999,999 or greater is displayed as "999999."														
Total Err	: Total errors during reception. The sum of Hamming Err, Trans Err and InvLine Err numbers indicated on the Detail screen. A number 999,999 or greater is displayed as "999999."														

[Tips] In a case where only "HS" is displayed in the MD column of the logs, the host channel has not been found. It is necessary to check the country and postal-code settings in the user settings.

2. Detail screen

[How to enter] Press the **[DIG/ANA]** key while the Summary screen is displayed. Up to 6 detail screens (1 to 6) are displayed, one each time the **[DIG/ANA]** key is pressed. Each detail screen 1 to 6 corresponds with the EPG reception error logs from the top on the Summary screen.

[How to quit] Press the **[ESC]** key.

[Description of the Detail screens]

```

0          1          2          3          4
012345678901234567890123456789012345678901234567
00 (EPG EURO)
01 EPG Data Receive Err Details - 1
02
03 Date : 03/31
04 Start Time : 13:00  END Time : 13:30
05 Host CH : 03      P-ON Kind : Download
06
07 Data Receive Info  Total Err : 000000
08 Pkt Rcv Num : 001853  Pkt Snd Num : 001853
09 Inv Line Err : 000000
10 Slice Cont : Auto  EQ : OFF  LV : -h
11
12 Temporary Buffer Information
13 Pool Num : 000000  Max Store : 000000
14 Discard Pkt : 000000

```

Line	Display item	Description	Remarks
Line 01	EPG Data Receive Err Details-X	The rightmost figure represents the number of the current detail screen. This number corresponds to the order of the EPG reception error log from the top.	
Lines 03-05, Reception conditions	Date Start Time END Time Host CH P-ON Kind	: Month/day when reception started : Time when reception started : Time when reception ended : Data-receiving channel : Methods for acquiring the EPG data (host scanning and downloading)	Only during initialization, host scanning is automatically executed to find the host broadcast.
Lines 07-10, details on errors during reception	Total Err	: Total numbers of errors during reception. The total number of Hamming Err, Trans Err and InvLine Err indicated on the Detail screen. A number 999,999 or greater is displayed as "999999."	Total Errors: If the total number of errors reaches two digits or greater, it is likely that EPG data acquisition failed. Display subscreen 1 of the first screen and check the electric field intensity from the AGC level.
	Pkt Rcv Num Pkt Snd Num	: Total number of received packages. A number 999,999 or greater is displayed as "999999." : Total number of packages that were sent to the application program among all the received packages. A number 999,999 or greater is displayed as "999999."	If the total number of received packages is 0, it is likely that the country and postal-code settings are wrong.
	InvLine Err	: Total number of errors that were generated by receiving data from invalid lines. A number 999,999 or greater is displayed as "999999."	
	Slice Cont	: Slice level control Auto-Tu Con, Manual - Syscon.	
	EQ	: Equalizer setting (ON, OFF)	
	LV	: Slice level (10-30 hex) (Only when the slice Cont is Manual.)	

Note: The data on lines 12-14 are for software development, not for service use.

6.7 HDMI SERVICE MODE

[Purposes]

To check the statuses of the connected HDMI devices.

[Tool to be used]

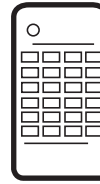

Remote control unit for servicing (GGF1381) • HDMI device
• HDMI cable

[How to enter]

• Press the **[ESC]**, then **[DISP]** key 24 times.

Note: Do not press any key on the remote control unit supplied with the unit or for servicing while the HDMI debug screen is displayed.

[How to quit]

Press the **[ESC]** key.

[Description of the mode]

1. HDMI MAIN information screen (First screen)

```

00 [HDMI] 1/6
01 Connect:*** Reso :***** Audio:***
02 DevType:**** Color:***** APath:*****
03 TMDS :*** HDCP :** :** Fs :***
      SType:
[Video Check]
Pic_Asp :
Active_Asp :
[Copyright Control Check]
ACP_Type: (Actual send: )
ChSts0: ChSts1: (C, L:)
[Digital Tuner]
HDMI Out: AC3 32kHz
LL SPDIF: AC3 32kHz DAC: 32kHz
    
```

(*1) [Tips]

Because all the data on connection and authentication are canceled once the function of the connected HDMI device is set to a position other than HDMI, all the debugging data in Table 1 are deleted.

Table 1: Description of the items on the HDMI main information screen

Line	Item	Description	Remark
1	Connect	Connection status of the HDMI device	See Table 2.
	Reso	Output resolution	See Table 3.
	Audio	HDMI audio output status	See Table 4.
2	DevType	Type of connected device	See Table 5.
	Color	Output color	See Table 6.
3	TMDS	TMDS (video stream) signal output status	See Table 7.
	HDCP	HDCP Authentication status	See Table 8.
	Fs	Output audio Fs	See Table 9.

Table 2: Connection status of the HDMI device

Indication	Description
ON	Connected
HotPlg	Not connected but Hot plug is ON.
OFF	Not connected

Table 3: Output resolution

Indication	Description
480i NTSC	720x480i NTSC
480p NTSC	720x480p NTSC
720p NTSC	1280x720p NTSC
1080i NTSC	1920x1080i NTSC
1080p NTSC	1920x1080p NTSC
576i PAL	720x576i PAL
576p PAL	720x576p PAL
720p PAL	1280x720p PAL
1080i PAL	1920x1080i PAL
1080p PAL	1920x1080p PAL
-----	TMDS Off

[Description of the Main screen] (Continued)

Table 4: HDMI audio output status

Indication	Description
OFF	Output: Off
ON	Output: On

When the unit is connected to DVI device (refer to Table 5), the Audio is not outputted.

Table 5: Type of the connected device

Indication	Description
-----	Not connected
HDMI	It has been confirmed that an HDMI device supporting HDCP is connected.
DVI	It has been confirmed that a DVI device supporting HDCP is connected.

When the unit is connected to device with no HDCP support, this display is "HDMI-" or "DVI-".

Table 6: Output color

Indication	Description
YCbCr4:2:2	Component 12 bits (YCbCr4:2:2)
YCbCr4:4:4	Component (YCbCr4:4:4)
RGB(0-255)	RGB full range (0-255)
RGB(16-235)	RGB (16-235)
-----	TMDS Off

Table 7: TMDS signal output status

Indication	Description
OFF	Output: Off
ON	Output: On

Table 8: HDCP

Left side : HDCP Authentication Status

Indication	Description
--	If an device supporting HDCP is connected, HDCP authentication is in progress.
OK	HDCP authentication succeeded.

Refer to this item only when HDMI or DVI is displayed for the item for the type of the connected device (Table 5). If OK is not displayed although HDMI or DVI is displayed, it means that the HDCP authentication failed.

Right side : Check Revocation list

Indication	Description
--	Checking that the connected device (all downstream devices) is not registered to the Revocation list, or so.
OK	The connected device (all downstream devices) is not registered to the Revocation list.

Refer to this item only when HDMI or DVI is displayed for the item for the type of the connected device (Table 5). When there is also no valid SRM (include Revocation list), "--" is displayed here.

Table 9: Fs

Indication	Description
32k	32kHz
44k	44.1kHz
48k	48kHz
96k	96kHz
96k/2	48kHz (original data of 96kHz is down-sampled.)
---	Audio Off

6.8 AGING MODE

[Purposes]

If symptoms regarding recording/playback of discs and/or the HDD that your customer claimed are difficult to reproduce, they can be reproduced with a long-time test in Aging mode.

[Tools to be used]



Remote control unit for servicing (GGF1381)

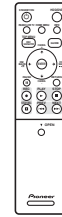

Remote control unit supplied with the unit (VXX3222)



Commercially available, recordable DVD-R/+R and DVD-RW/+RW/-RAM discs

[Notes]

- When aging for the DVD-RW/+RW/-RAM and HDD is executed, all recorded data on them will be erased.
- Commands from the remote control unit are accepted during Aging mode.
- If aging mode is quit using the ESC key, indications on the FL display will return to normal display.
- Cancel timer settings before entering Aging mode.
- Set the recording rate beforehand. It cannot be changed during Aging mode.

[How to enter]

- ① Press the **[DVD]** key to switch to DVD.
- ② Load a recordable disc.
- ③ Select the input function of a recordable source.
- ④ After disc detection is performed, press the **[ESC]** then **[REP.B]**, and then **[PLAY]** keys on the remote control unit for servicing to enter Aging mode.

[How to quit]

Press the **[ESC]** key on the remote control unit for servicing to quit Aging mode and return to Normal mode.

Notes:

- If during recording: Recording is stopped.
- If during playback: Playback is paused. (aging for \pm RW/-RAM only)
- If during initialization: The unit stops after initialization is finished. ←
- If the tray is being opened/closed: The unit stops after the tray is opened/closed. ←

[Description of operation] Aging for the DVD-RW/DVD-R

Aging for the DVD-RW/+RW/-RAM	Aging for the DVD-R/+R
<p>During Aging mode, the following operations are repeated in the order shown below.</p> <ol style="list-style-type: none"> ① The tray opens. ② The tray closes. ③ Initialization ④ Recording for 60 minutes ⑤ Playback for 45 minutes <p><DVD-RW> The initialization process in step 3 follows the setting specified in "Disc setting--Basic--Auto initialization of a DVD-RW."</p> <p><DVD+RW> The initialization process in step 3 is the same as that described in "Disc setting--Initialization--Initialization of a DVD+RW."</p> <p><DVD-RAM> In the initialization process in step 3, physical formatting is performed, if required.</p> <p>During Aging, the number of loops is indicated on the FL display, as shown below. [AGING 0001]</p> <p>If an error is generated, the aging operation stops. Note: Indications on the FL display are retained, and this information is also retained as an OSD.</p>	<p>During Aging mode, the following operations are repeated in the order shown below.</p> <ol style="list-style-type: none"> ① The tray opens. ② The tray closes. ③ Recording for 1 minute ④ Recording pause for 6 minutes ⑤ Recording stops. ⑥ Playback for 1 minute ⑦ Playback pause for 6 minutes ⑧ Playback stops. <p>Note: A continuous test of the above operations is possible for approximately 23 hours.</p> <p>After ② the tray closes, disc detection is performed, <DVD-R> In step 2, if the disc is judged to have recorded up to 99 titles, the operation stops at that point.</p> <p><DVD+R> If the disc is judged to have recorded up to 49 titles, the operation stops at that point. On the FL display, the number of loops is retained. On the OSD display, the error indication is retained.</p> <p>During Aging, the number of loops is indicated on the FL display, as shown below. [AGING 0001]</p> <p>If an error is generated, the aging operation stops. Note: Indications on the FL display are retained, and this information is also retained as an OSD.</p> <p>Note: Recording time depends on the recording rate set. For example, if the recording rate is MN32, only up to 60 titles can be registered. Check the setting for recording rate before performing aging.</p>

[Aging for the HDD]

- [How to enter]**
- ① Press the **[HDD]** key to switch to HDD.
 - ② Press the **[ESC]** key then the **[REP.B]**, and then the **[PLAY]** keys on the remote control unit for servicing to enter Aging mode.

[How to quit] Press the **[ESC]** key on the remote control unit for servicing to quit Aging mode and return to Normal mode.

Notes:

- If during recording: Recording is stopped.
- If during playback: Playback is paused.
- If during erasure of all memory data from the HDD, the unit stops after all memory data have been erased.

[Description of operation]

During Aging mode, the following operations are repeated in the order shown below.

- ① Erasure of all the memory data from the HDD
 - ② Recording for 60 minutes
 - ③ Playback for 60 minutes
- * Take caution as all recorded data of the HDD is deleted.

[Tips]

During Aging, the number of loops is indicated on the FL display, as shown below.

[AGING 0001]

If an error is generated, the aging operation stops.

Note:

Indications on the FL display are retained, and this information is also retained as an OSD.

6.9 USB CHECK MODE

[Purposes]

As this unit is provided with two USB ports, operation checks of these ports are possible by connecting them (loop connection).

[Tools to be used]



USB cable
(GGD1445)

Remote control unit
supplied with the unit
(VXX3222)



Remote control unit for servicing
(GGF1381)

[How to enter this mode]

1. Connect Connector A (at the front panel) and Connector B (at the front panel), using a USB cable.
2. Enter USB Check mode.
Press the **[ESC]** key on the remote control unit for servicing then press the **[TIMER REC]** key on the remote control unit supplied with this unit.

[How to quit]

To quit while the ports are operating properly ("USB CHK OK" is lit.): Press the **[ESC]** key or the **[clear]** key.
To quit while port operation is abnormal: Turn the power off then back on.

[Procedures]

1. Check the indication on the FL display.
When the two ports are operating properly: "USB CHK OK" is lit.
When port operation is abnormal: "USB CHK NG" is lit.
2. When "USB CHK OK" is lit in Step 1, disconnect the USB cable in order to perform the detachment/attachment test.
The indication on the FL display will change, as follows:
If the result is OK: "USB CHK OK" will flash.
If the result is not OK: "USB CHK OK" will remain lit.

[Troubleshooting]

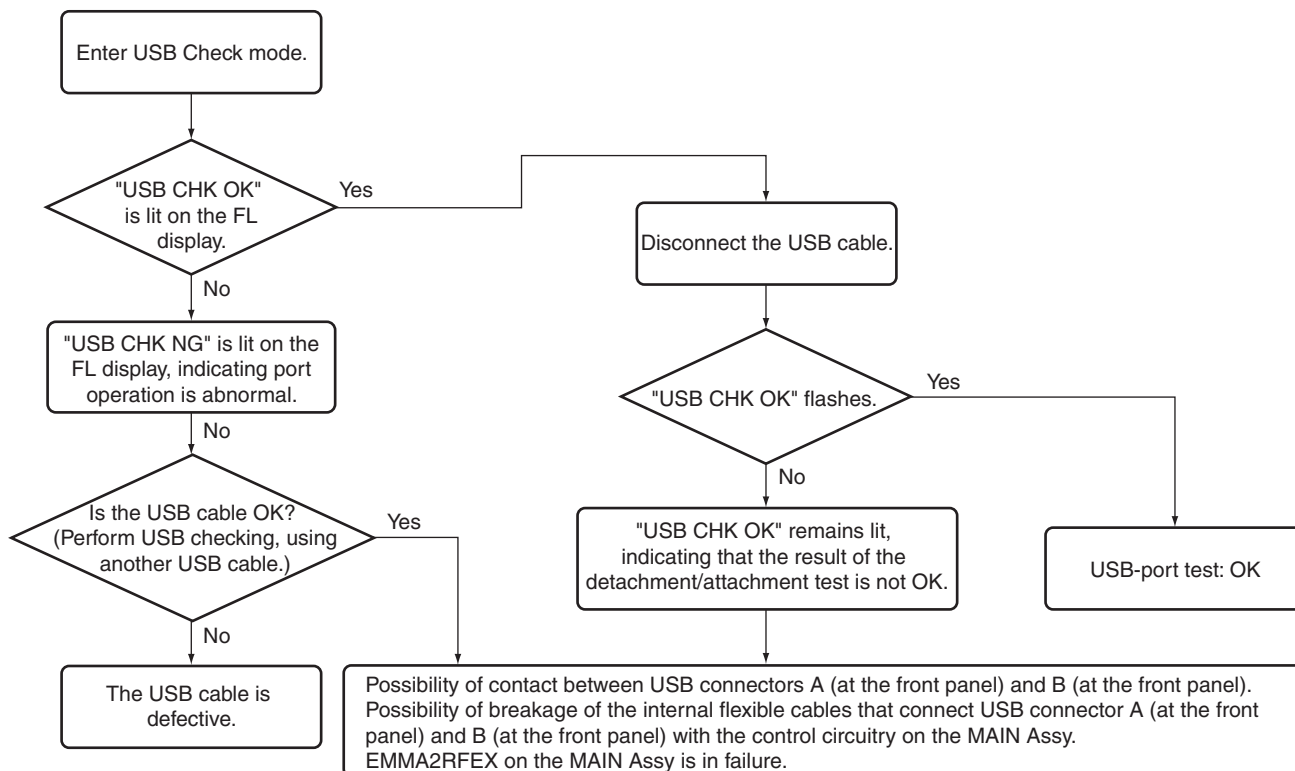

6.10 HDD CHECK MODE

◆ How to Diagnose Failure of the Hard Disc Drive (HDD)

Purpose:

With use of the HDD-diagnostic program contained in the product itself, physical errors on the HDD can be diagnosed. Use this program to diagnose whether or not the HDD is in failure when one of the symptoms indicated below is recognized, or when a failure in the HDD is suspected.

Symptoms of failure in HDD:

- (1) HDD Error
- (2) Failure in HDD recording or playback
- (3) HDD not recognized

Tool to be used:

Remote control unit for servicing (GGF1381)

◆ Flow of HDD Diagnosis

(1) Flowchart of HDD diagnosis

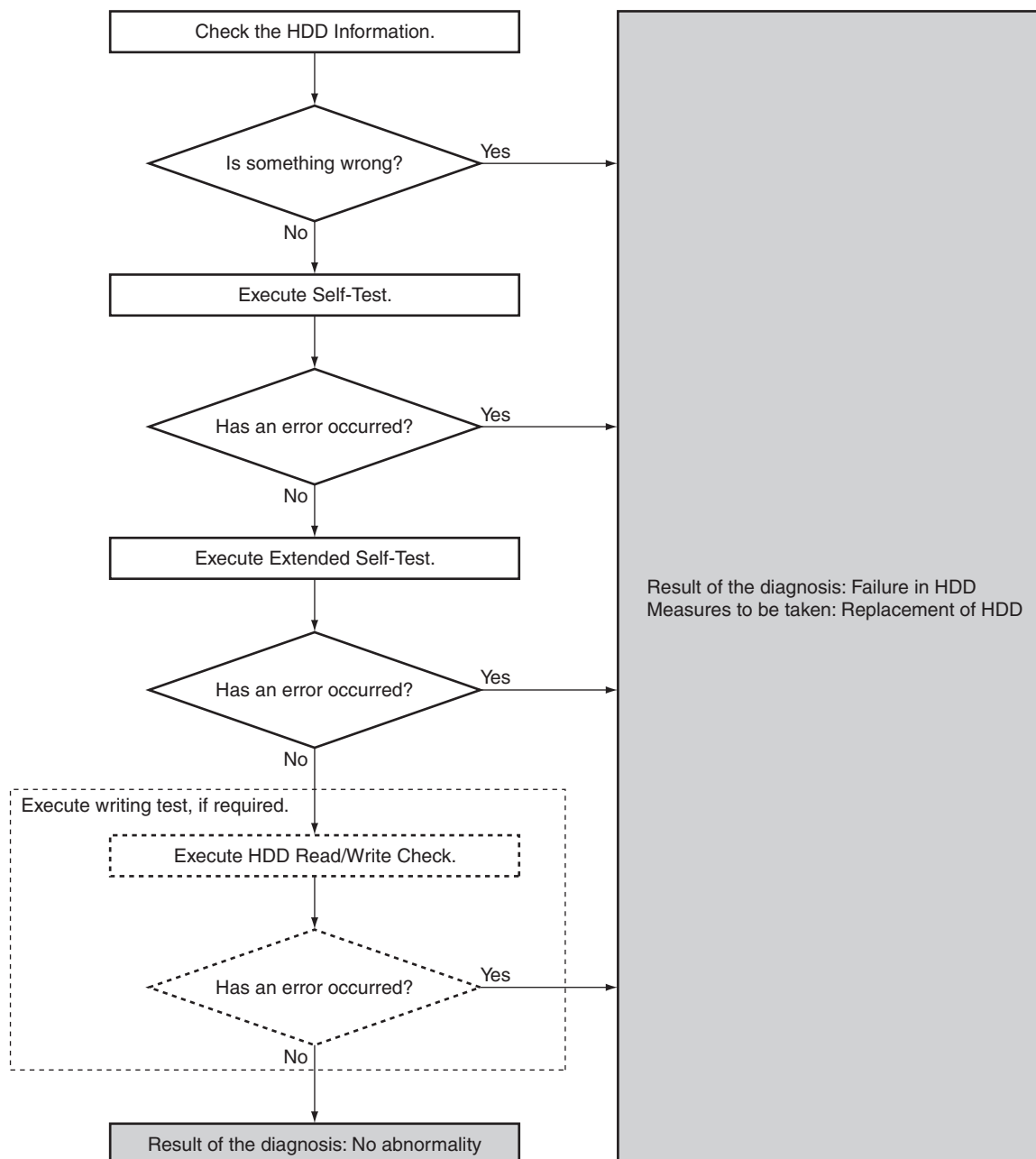

(2) Overview of the diagnosis items

HDD Information

This is a display for checking the HDD information, such as the model name of the HDD, continuous power-on time, authentication status, and results of the diagnosis on the end of service life.

SELF TEST

This is a simplified diagnosis for the HDD.
A serious failure in the HDD can be detected with this test.
Time required for testing: Approx. 60 sec.

EXTENDED SELF TEST

This is a reading test across all sectors of the HDD.
Data recorded on the HDD will not be erased, because no writing operation is performed.
Time required for testing: Approx. 3.2 hours/250 GB (DVR-LX60)
2 hours/160 GB (DVR-550H-S)

HDD Read / Write Check

This is a writing, reading, and comparing test across all sectors of the HDD.
All data recorded on the HDD will be erased, because all the data are to be overwritten. **Be sure to obtain your client's consent beforehand.**
Time required for testing: Approx. 10 hours/250 GB (DVR-LX60)
6.4 hours/160 GB (DVR-550H-S)

◆ How to Start or Terminate the Diagnostic Program

How to start/terminate the diagnostic program

Use the remote control unit for servicing.

How to start: Press the "ESC", "CX", "0", and "1" keys simultaneously.

How to terminate: Press the "ESC" key.

Do NOT perform other operations on the unit while the HDD diagnosis is in progress. Although the diagnostic program is designed to function independently from the unit's functions, an operation on the unit during a diagnosis may cause a malfunction.

The status of the unit recommended during diagnosis is as follows: All stop, no timer recording (including auto-recording), and Input selection to L1-L3.

◆ Diagnosis Procedures

① Display the menu on the screen.

The menu indicated below is displayed when the diagnostic program is started. To enter each mode, press the corresponding key "1"- "4" on the remote control unit for servicing.

```

HDD CHECK MODE      [1-4]

1 HDD Information
2 S.M.A.R.T. Attribute Information
3 S.M.A.R.T. DST
4 HDD R/W Check
  
```

Tests to be executed

- ① HDD Information:
Check of the HDD information
- ② S.M.A.R.T. DST:
Executing a simplified test or a reading test of all data
- ③ HDD R/W Check:
Executing a writing/reading test of all data. All data on the HDD will be erased if this test is executed.

Note: "2. S.M.A.R.T. Attribute . . ." is not to be used.

② Check the HDD information.

Press the "1" key on the remote control unit for servicing. Check the following data:

Model: Is the correct model name of the HDD displayed?

Recog. No: Is a positive value displayed?

SMART threshold: Is "not exceeded" displayed?

```

HDD Information
Cylinders:0x3FFF   Heads:0x0010
Sec/Track:0x003F
➤ Model :Maxtor 4R080L0
Firmware :RAMC1TU0
SN       :R22RRL2SE
Major No :ATA/ATAPI-7
Life Time:33h 10m 30s
➤ Recog. No:-1
➤ SMART threshold: not exceeded
  
```

Detailed description

- ① Model:
For the correct model name, refer to the display of the unit.
- ② Recog. No:
Positive value: The HDD has been authenticated.
Negative value: The HDD has not been authenticated.
- ③ SMART threshold:
exceeded: The HDD has come to the end or near the end of its service life.
not exceeded: The HDD has not reached the end of its service life.

To return to the menu screen, press the "Clear" key.

③ Execute Self-Test.

Press the "3" key on the remote control unit for servicing while the menu screen is displayed. When the following screen is displayed, press the "1" key to start the Self-Test.

A

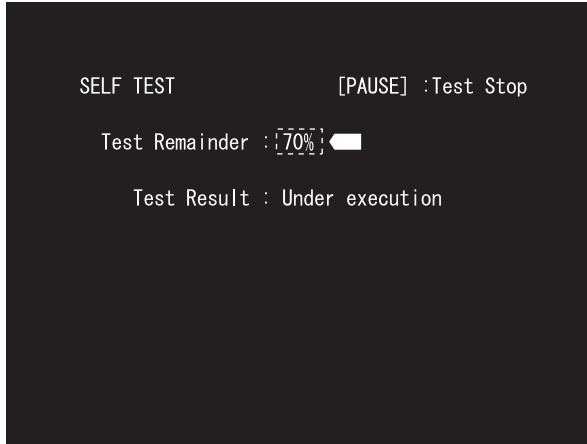
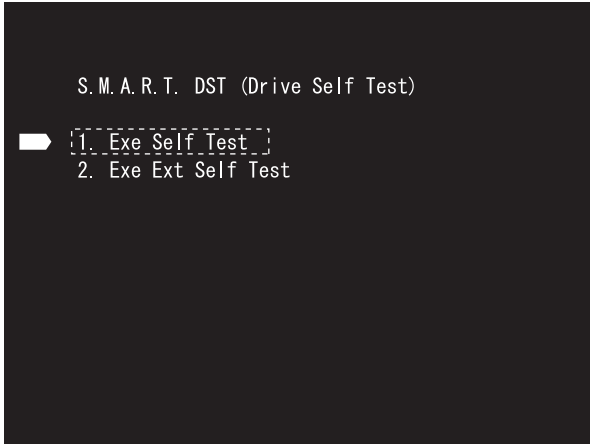

B

The progress of the test is displayed on the screen. The percentage remaining of the test is displayed on the screen, and the test is terminated when the percentage reaches 00%. Check whether or not an error has occurred after the test is finished.

Diagnosis results

- Without an error: "... Completed" is displayed. Then, proceed to the Extended Self-Test.
- With an error: "... Error" is displayed. Look at the number in Test Result. If the place value for tens is 1 or 2, execute the Self-Test again. If it is from 3 to 7, the HDD must be replaced.

Note: If the result of the second test is the same, replacement of the HDD is required.

C

Example: No error

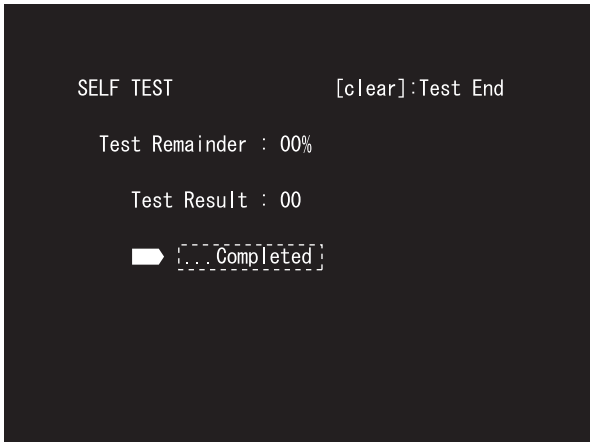

D

Example: With an error

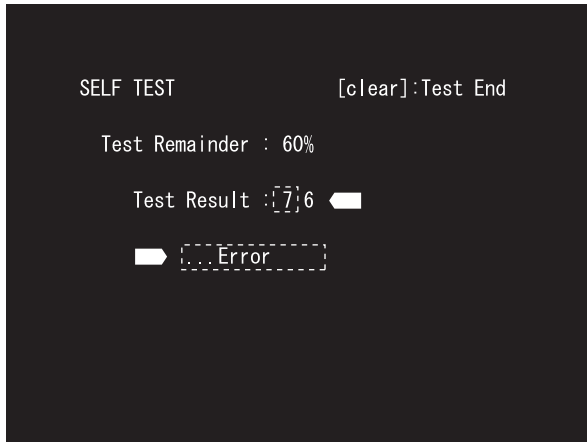

E

To return to the menu screen, press the "Clear" key.

F

④ Execute the Ext (Extended) Self-Test.

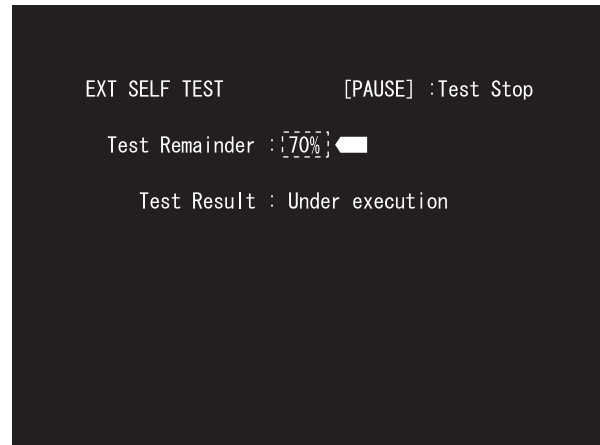
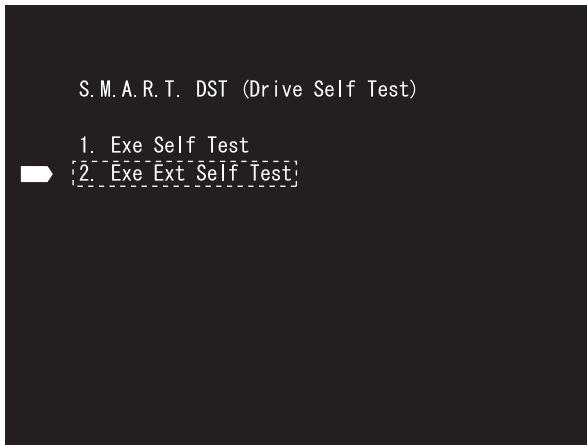

Press the "3" key while the menu screen is displayed, then the "2" key on the remote control unit for servicing. The Extended Self-Test starts. The percentage remaining of the test is displayed on the screen, and the test is terminated when the percentage reaches 00%. Check whether or not an error has occurred after the test is finished.

Diagnosis results

- Without an error: "... Completed" is displayed.
If no error occurs up until this stage, HDD operations are normal except for writing operations.
If the unit has a failure in HDD playback, a block other than the HDD may be in failure.
If the unit's failure is in HDD recording, however, the next HDD Read/Write Check must be executed to test writing operations.
- With an error: "... Error" is displayed.
Look at the number in Test Result.
If the place value for tens is 1 or 2, execute the Ext Self-Test again.
If it is from 3 to 7, the HDD must be replaced.

Note: If the result of the second test is the same, replacement of the HDD is required.

Example: No error

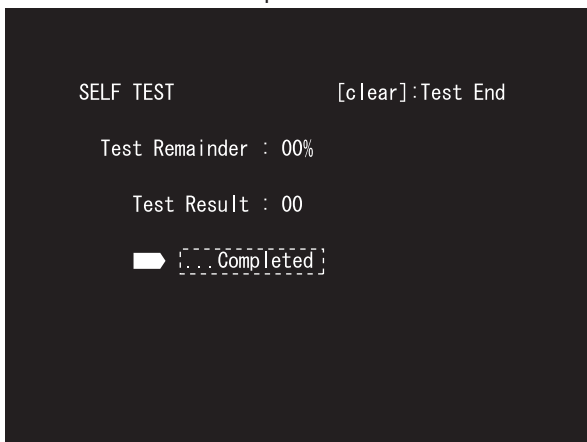

Example: With an error

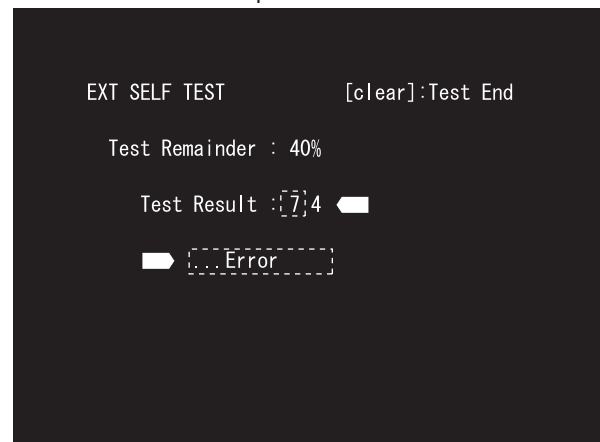

To return to the menu screen, press the "Clear" key.

⑤ Execute the HDD R/W Check.

Before executing this test, **be sure to obtain your client's consent for erasure of HDD data.**

Press the "4" key while the menu screen is displayed then the "SKIP ►►1" key to start the HDD R/W Check.

To stop executing the test (OFF) while it is in progress, press the "SKIP ◀◀1" key.

HDD R/W CHECK OFF | ON

Caution! This test overwrites all sectors.

Write Error : 0
Read Error : 0
Compare Error : 0
Current LBA : 0
Max LBA : 160086528
Progress : 0 %

Remain Time : ---h --m --s

The display on the left indicates the progress of the test. The percentage of the test progress is displayed on the screen, and the test is finished when the percentage reaches 100%.

HDD R/W CHECK OFF | ON

Caution! This test overwrites all sectors.

Write Error : 0
Read Error : 0
Compare Error : 0
Current LBA : 17940484
Max LBA : 160086528
Progress : 11 %

Remain Time : 5h 59m 11s

Detailed description on each item on the screen

- Write Error: Number of write errors
 - Read Error: Number of read errors
 - Compare Error: Number of comparison errors
 - Current LBA: The address during testing
 - Max LBA: Highest address number of the HDD
 - Progress: Percentage of test progress (%)
 - Remain Time: Estimated time required for finishing the test across all sectors.
- Estimated time: 10 hours/250 GB (DVR-LX60)
6.4 hours/160 GB (DVR-550H-S)

Diagnosis results

- If no error occurs in any of the Write/Read/Compare items, the HDD is in normal condition and is not required to be replaced. A block other than the HDD is in failure.
- If any error occurs, the HDD must be replaced.

To terminate the diagnostic program, press the "ESC" key.

7. DISASSEMBLY

Note 1: Do NOT look directly into the pickup lens. The laser beam may cause eye injury.
Note 2: Even if the unit shown in the photos and illustrations in this manual may differ from your product, the procedures described here are common.

◆ Diagnosis

1 Bonnet

- ① Remove the five screws.



- ② Remove the four screws.
- ③ Remove the bonnet.

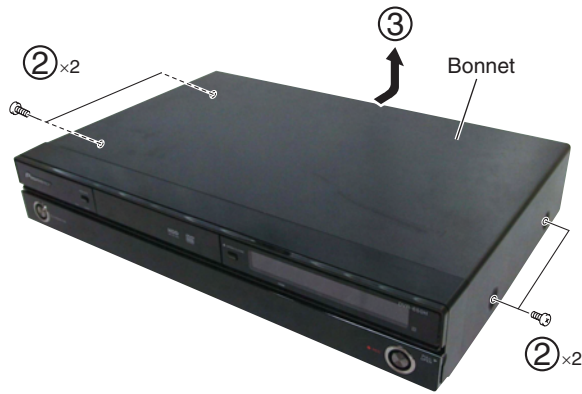

2 Tray Panel

- ① Press the STANDBY/ON button to turn on the power.
- ② Press the OPEN/CLOSE button to open the tray.
- ③ Remove the tray panel.
- ④ Press the OPEN/CLOSE button to close the tray.
- ⑤ Press the STANDBY/ON button to turn off the power.

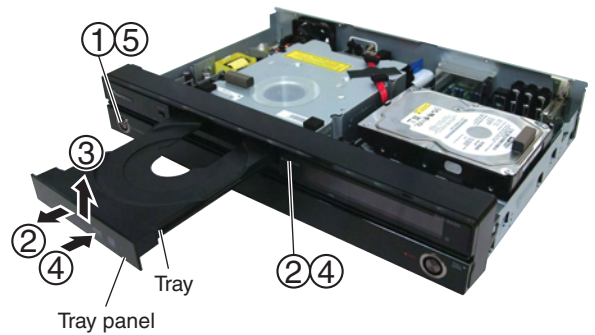

● How to open the tray when the power cannot be turned on

When the tray cannot be opened because the power cannot be turned on, it can be opened using the emergency disc ejection rod (GGF1529). (A long, thin rod about 1 mm in diameter can be used in place of the rod.)

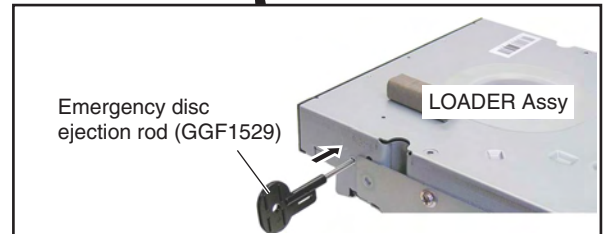
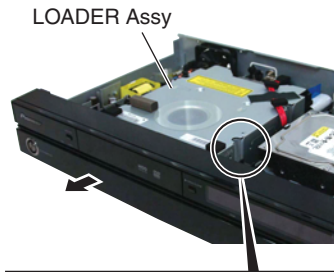

3 Front Panel Section

① Unhook the four hooks.

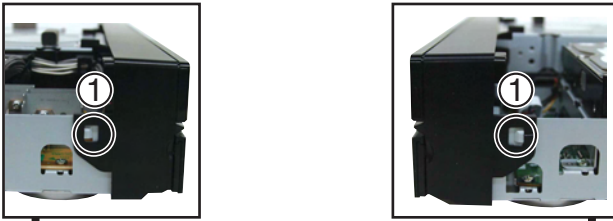

② Disconnect the one flexible cable.
 ③ Remove the front panel section.

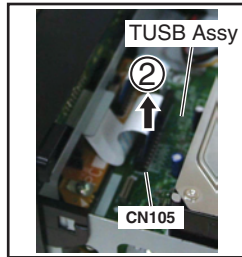

Front panel section



4 HDD and LOADER Assy

• HDD

① Remove the two screws.
 ② Remove the two screws.

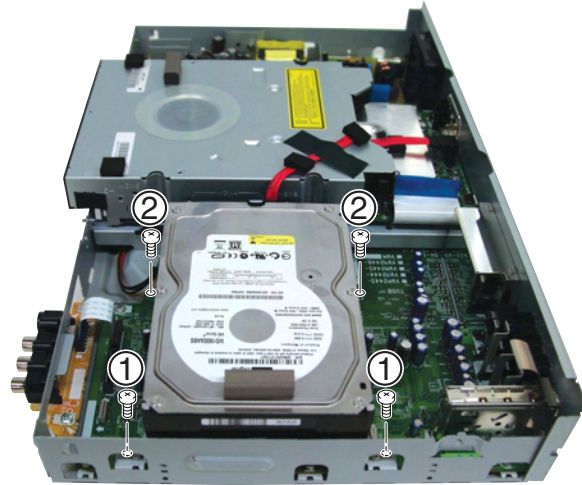

• LOADER Assy

① Disconnect the three connectors (CN201, CN901, CN902).

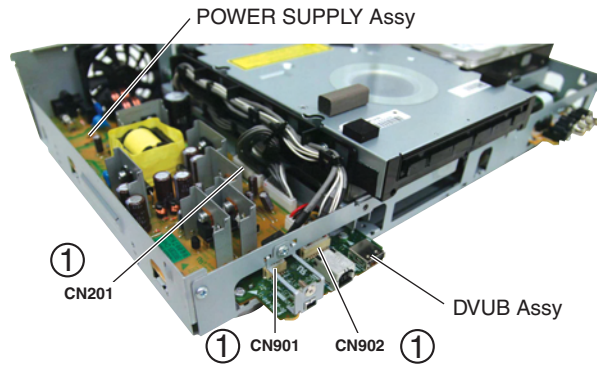

- ② Remove the six screws.
- ③ Remove the screw(Rear Panel Side).
- ④ Remove the screw(Rear Panel Side).

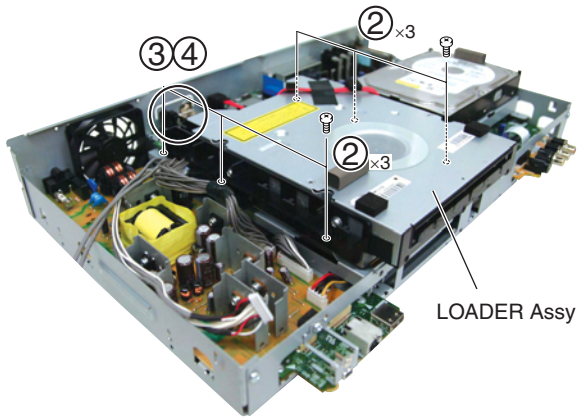

A
B
C
D
E
F

5 Diagnosis

- ① Connect the flexible cable for service.
- ② Connect the flexible cable for service.
- ③ Reassembling the front panel section.
- ④ Arrange the unit as shown in the photo below.

↓

Diagnosis

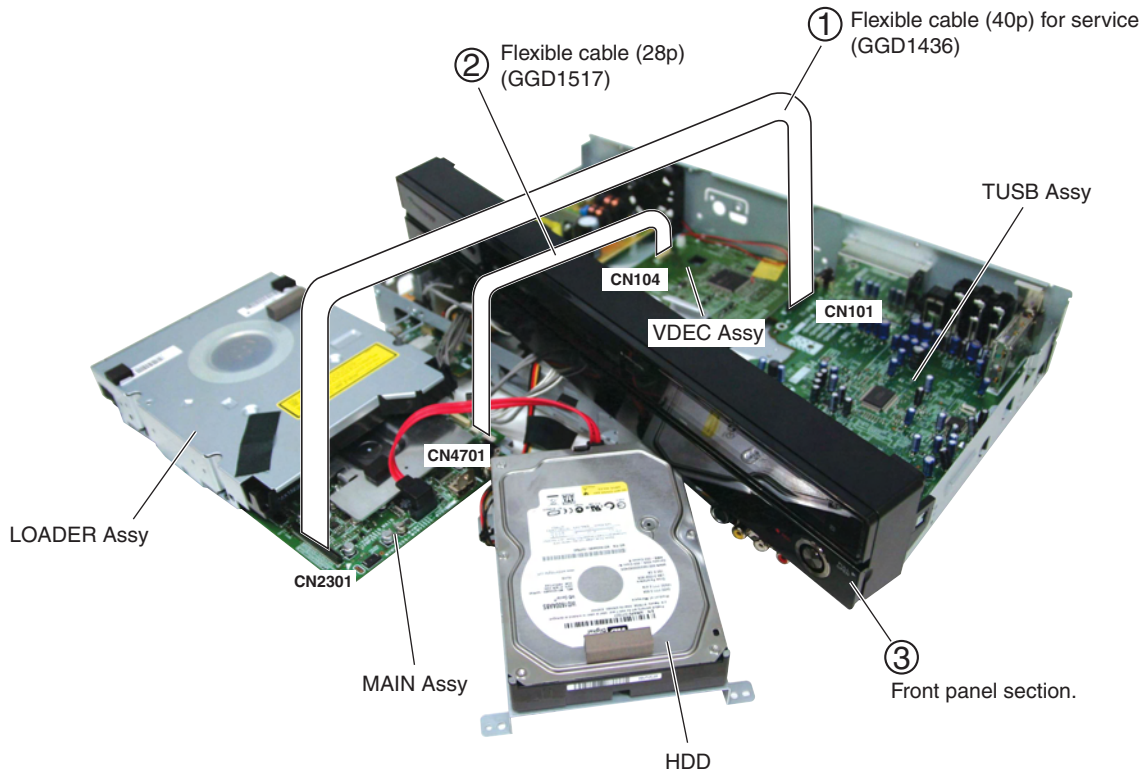

◆ Access to the MAIN Assy, Cleaning the Pickup Lens

• Writer Stay L and R

① Remove the two screws and CORD HOLDER.

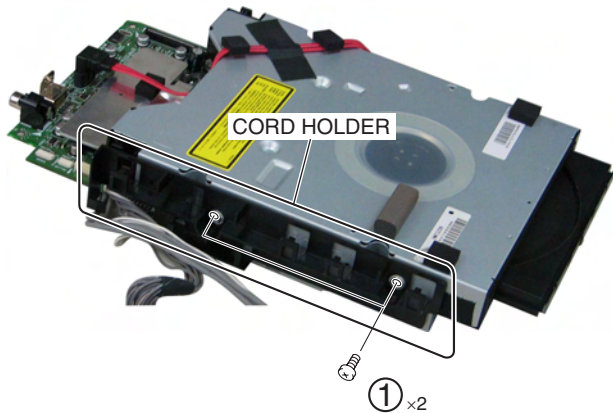

• Low Case U11 and Loader Assy

- ① Remove the four screws.
- ② Remove the low case U11.
- ③ Remove the tape.

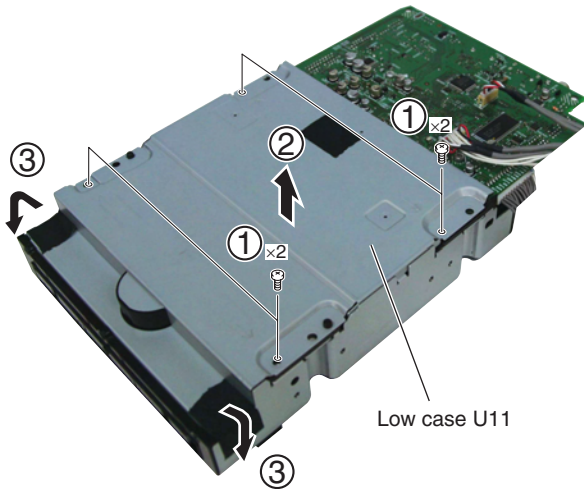

● Bottom view



MAIN Assy



● Bottom view

④ Remove the Loader Assy.

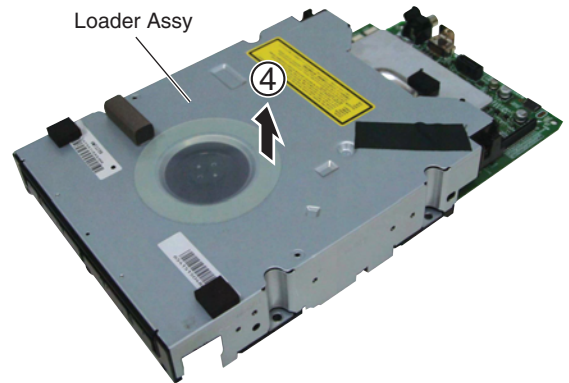

Before shipment, be sure to clean the pickup lens, using the following cleaning materials:

- Cleaning liquid : GEM1004
- Cleaning paper : GED-008

Pickup lens

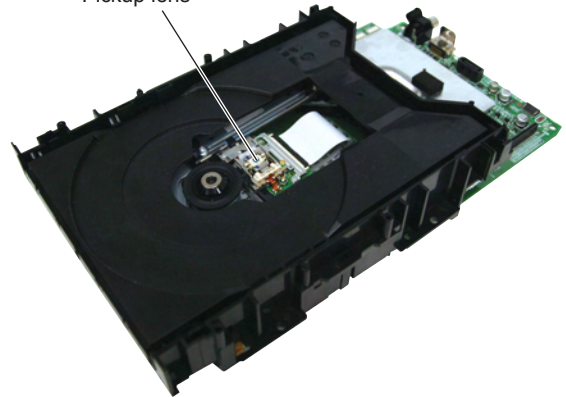

A
B
C
D
E
F

8. EACH SETTING AND ADJUSTMENT

8.1 MODEL SETTING

[Purposes]

When the MAIN Assy and/or TUJB Assy that are(is) commonly used with another model are(is) replaced, they(it) must recognize the model of this unit.

Items to be set: The model number, destination, and region No. must be set.

[Tool to be used]

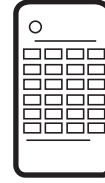

Remote control unit for servicing (GGF1381)

[Notes]

- Once the setting has been made, it can never be changed. Be sure to make the setting correctly.
- As this setting resets the Assy(s) in question to the factory-preset status, it is recommended that you obtain the customer's consent beforehand.

[Procedures]

- ① After power on, the following screen is displayed on TV monitor. Press "1" by using the remote control unit for service. Do not choose "2" as it is for OEM models. If you have chosen "2", disconnect the AC power cord.

[Recorder's Model Setting]
Input the number using the remote for Service

> ?

Input No.	Manufacturer
[1 : P]	
[2 : S]	

- ② The following screen is displayed on TV monitor. Press four digits properly (for example "0201") by using the remote control unit for service, according to the screen information.

[Recorder's Model Setting]
Input the number using the remote for Service

> ----

Input No.	Model
[0101 : DVR-550H/WY]	
[0201 : DVR-LX60/WY]	
[0102 : DVR-550H/WV]	
[0202 : DVR-LX60/WV]	
[0103 : DVR-550H/YRE]	
[0203 : DVR-LX60/YRE]	

- ③ Disconnect then reconnect the AC power cord of the unit. Be careful not to impart vibration to the unit immediately after the AC power cord is disconnected.

DVR-LX60/WV VERSION : 0.53
SYSCON : RELEASE_74
 Rev.1.4978
TUNERCON : 1.155 OK
DRIVE : DVD-RW DVR-L12X OK
 0.16 OK
PIC SERIAL : 000800004433
HDD INT : ST3300820SCE 300

- ④ Reset the recorder to all its factory settings. (Make sure that the recorder is on. Press and hold **■** (STOP) key and press **⏻** (STANDBY/ON) key on the front panel.)
The recorder turns off with all settings reset.

DEVICE : E2R-FEx1.0 FLASH : 64M
REGION : 2 C : 0000000001
 HDCP : 0000000001

- ⑤ Press [ESC] then [DISP] keys by using the remote control unit for servicing, and then confirm each Model Name (for example "DVR-LX60/WY").

- ⑥ End

8.2 LD POWER ADJUSTMENT

[Purposes]

If a combination of a main board and PU is changed, the LD power adjustment and adjustment for disc judgment needs to be made for a new combination of the main board and PU since the adjusted LD-power value becomes inappropriate for the new combination and stable playback and recording to disc becomes impossible.

[Tools to be used]

GGF1381 : Service Remote Control Unit
GGV1054 : CD-ROM (CDT-313)
GGV1036 : DVD-ROM DL (DVDT-002)
GGV1278 : Blank DVD-R (That's DR-C12WTY5PA)
GGV1282 : Blank DVD-RW (JVC VD-W120XH5)
GGV1284 : Blank DVD-RAM (maxell DRM120C.1P5S)

[Notes]

- Never turn the power off while any of the following operations is in progress:
- While laser diode (LD) power adjustment is being performed normally by the unit
 - While adjustment for disc judgment is being performed

[Explanation on each adjustment mode]

• Drive Adjustment Mode

This mode is used to select each mode for LD power adjustment.
In this mode, you can confirm an 11-digit number provided for the LD power adjustment.
The 11-digit number is stored in FLASH (IC200) of the main board.

• PU Data Setting Mode

This mode is used to enter an 11-digit number provided for the LD power adjustment.
If you have changed a combination of the main board and PU, enter an 11-digit number marked on the case of a loader which is provided in pairs with PU.
The LD power adjustment is made by using this 11-digit number.



• Power Adjustment Mode

This mode is used to execute the LD power adjustment and to check the progress of the adjustment.
In case an error occurs during the adjustment, you can also check the error details in this mode.

[How to enter Drive Adjustment Mode]

To enter the Drive Adjustment Mode, press [ESC]+[CX]+[1]+[0] on the remote control unit for service.

Though the LD power adjustment can be executed irrespective of the product functions, do not operate the product during the LD power adjustment to prevent misadjustment.

[Operation procedure]



- 1. When you enter the Drive Adjustment Mode, the following screen is displayed. On this screen, you can check 11-digit numeric data stored in FLASH of MAIN Assy, and can also switch over between each mode.

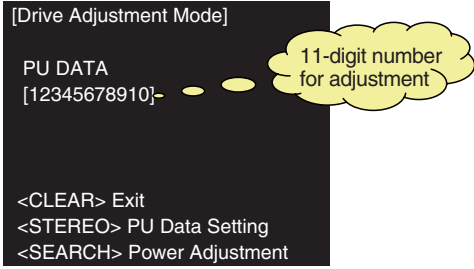

- 2. To enter the PU Data Setting Mode, press [STEREO] on the remote control unit for service. Entering the PU Data Setting Mode displays the following screen.

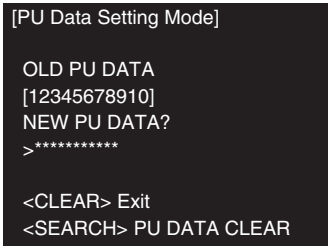

- 3. By pressing [0] to [9] keys on the remote control unit for service, enter an 11-digit number marked on the case of a loader provided in pairs with PU. Entering the 11-digit number displays the following screen.

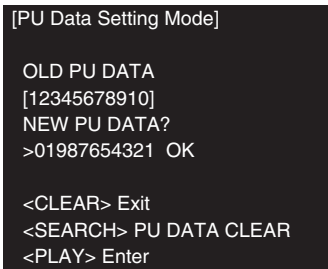

- 4. To enter the 11-digit number, press [PLAY] on the remote control unit for service. The 11-digit number contains 2-digit checksum data to prevent input errors. The screens displayed for the correct/incorrect check sum are as follows.

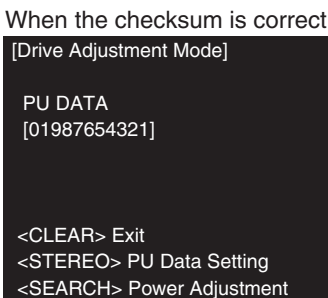

When the checksum is correct
Enter the Power Adjustment Mode and execute the LD power adjustment, as described in 5.

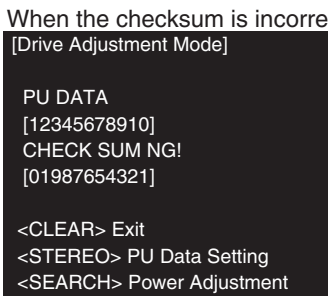

When the checksum is incorrect
The input data may be incorrect. Return to 2 and enter the PU Data Setting Mode to re-enter the 11-digit number.

5. When the checksum is correct, enter the Power Adjustment Mode and execute the LD power adjustment. To enter the Power Adjustment Mode, press [SEARCH] on the remote control unit for service. Entering the Power Adjustment Mode displays the following screen and opens the tray automatically.

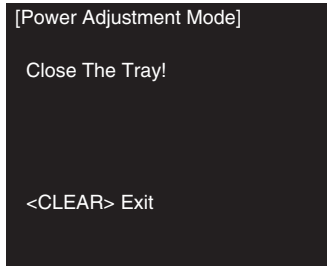

When the tray does not open

- Check if flexible cables and wire rods are connected properly.
- Errors in the loader, main board, or power source board are suspected.

6. Close the tray manually to execute the LD power adjustment mode. You can check the progress of adjustment in the following screen.

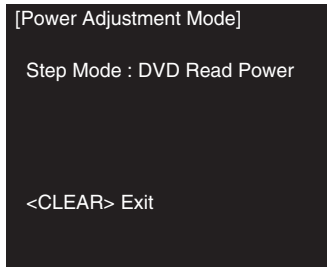

Explanation on Step Mode (time needed)

- DVD Read Power (approx. 10 sec.)
Adjustment of DVD playback power
- RAM Read Power (approx. 20 sec.)
Adjustment of RAM playback power
- DVD Write Power (approx. 40 sec.)
Adjustment of DVD recording power
- CD Read Power (approx. 10 sec.)
Adjustment of CD playback power
- DVD Disc Judgment (approx. 30 sec.)
Adjustment for DVD disc judgment
- CD Disc Judgment (approx. 30 sec.)
Adjustment for CD disc judgment

7. When DVD Disc Judgment is displayed in the Step Mode, the tray opens automatically. Place DVDT-002 in the tray. The tray closes after 15 seconds from the time it opened. If the adjustment for DVD disc judgment is completed successfully, CD Disc Judgment is displayed in the Step Mode.

If the adjustment for DVD disc judgment is not completed successfully

- A disc other than DVDT-002 may have been placed.
Place DVDT-002 in the tray.

8. When CD Disc judgment is displayed in the Step Mode, the tray opens automatically. Place CDT-313 in the tray. The tray closes after 15 seconds from the time it opened. If the adjustment for CD disc judgment is completed successfully, the following screen is displayed. Since the judgment is completed successfully, press [CLEAR] on the remote control unit for service and exit from the adjustment mode.

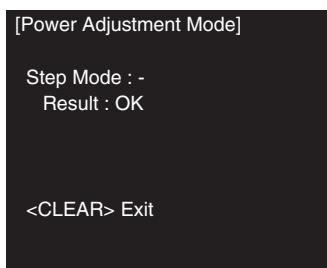

If the adjustment for CD disc judgment is not completed successfully

- A disc other than CDT-313 may have been placed.
Place CDT-313 in the tray.

9. Turn off the power.

[Error information]

In case of errors in the Power Adjustment Mode, the following screen is displayed.

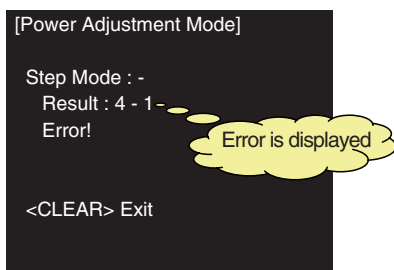
**About error indication****[Left number]**

The left number indicates the Step Mode in which the error has occurred.

- 2: Adjustment of DVD playback power
- 3: Adjustment of RAM playback power
- 4: Adjustment of DVD recording power
- 5: Adjustment of CD playback power
- 6: Adjustment for DVD disc judgment
- 7: Adjustment for CD disc judgment

[Right number]

The right number indicates the error information.

1 or 2: Error in the adjustment process

(Details of error)

- The PU flexible cables may not have been connected.
- TM or main board error is suspected.

3: Forced termination

This number is displayed when you pressed [CLEAR] on the remote control unit for service and executed forced termination.

[Contents to check]

1. Record the data to a designated disc (DVD-R / DVD-RW / DVD-RAM) in real time.
2. Measure an error rate at a place where recording is executed.
Measurement method: Refer to the simplified error rate measurement method in the Service Mode.
3. Check that the error rate is 1e-3 or below.

If the error rate is out of specification

- Check if there is any defect or fingerprint on the disc. If you find any problem with the disc, change the disc and try the check again.
- The power adjustment may have been unsuccessful.
Try the power adjustment again.

If the above two do not solve the problem, a defect with MAIN Assy or PU is suspected.

8.3 CPRM ID NUMBER AND DATA SETTING

[Purposes]

For the DVD recorder, it is necessary with the recoding/playback of DVD-RW disc to set an individual number (ID number) and ID data to each recorder. If the number and data are not set correctly with the following procedure, cannot work with residual quantity 0:00 or operations in the future may not be guaranteed with RW disc. You will find the ID number to be set on the ID label on the rear panel.

The Input is Necessary When:

- " CPRM ERR" is displayed on the FL display immediately after the power is turned on or in Stop mode.
- When the MAIN ASSY or the HDD is exchanged.

[Tools to be used]

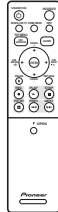

Remote control unit supplied with the unit (VXX3222)



Remote control unit for servicing (GGF1381)



DVD Recorder Data Disc (Type 2)

Be sure to use the latest disc (Type 2).
In Feb, 2007, the latest disc is GGV1305.

[Notes]

Important: If no ID label is found on the rear panel, write down the specified ID number by checking it according to "How to confirm the ID number" shown below.

- Input the ID number while the unit is in Stop mode.
- After the data are read from the data disc (Type 2), the disc will automatically be unloaded.

◆ Input Flow of the ID No. and ID Data When Exchanging HDD or MAIN Assy

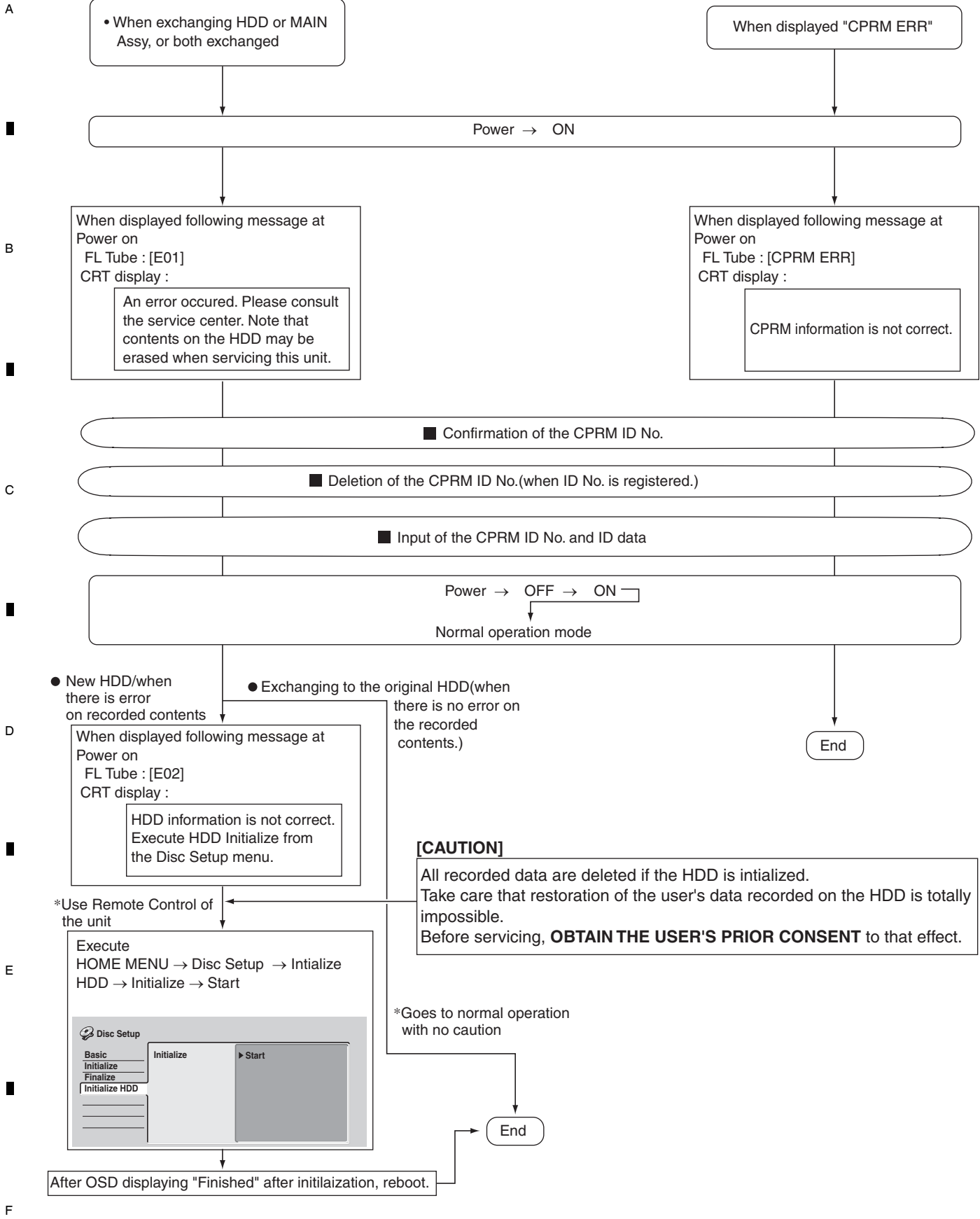

◆ How to Input the ID Number and ID Data

- ① To enter the input mode, press **[ESC]+[STEREO]** keys sequentially in a status with no ID number set, such as after FLASH-ROM downloading.



- ② As number input is enabled when the unit enters the input mode, input the 9-digit ID number.
(The entered number is also displayed on the FL display.)

[Recorder's ID Number Setting]
ID Number ?
> -----
<CLEAR> Exit

Input ID Number !



- ③ After inputting the number, press **[SEARCH]** keys to register the ID number.

[Recorder's ID Number Setting]
ID Number ?
> 0 0 0 0 0 0 0 0 1 OK ?
<PLAY> Compare Mode
<SEARCH> Enter

Input ID Number !



- ④ When the ID number has been registered, the unit enters the ID data input mode. (The FL display indicates "INSERT ID.")
In this condition, place the ID data disc on the tray and close the tray using the CLOSE key "■/▲" on the player.

[Recorder's ID Data Setting]

<CLEAR> Exit

Insert The ID Data Disc !



- ⑤ While the data are being read, the message shown in the figure at left is displayed on the screen.
(The FL display indicates "LOAD ID.")

[Recorder's ID Data Setting]

Loading The ID Data Disc !



- ⑥ When the ID data have been read, the data are written to the FLASH-ROM.
(The FL display indicates "WRITE ID.")

[Recorder's ID Data Setting]

Wait Rom Writing !



- ⑦ When the ID data have been written to the FLASH-ROM, the message "Rom Write OK" is displayed on the screen.
(The FL display indicates "ID OK.")

- ⑧ After confirming this message, press **[CLEAR]** key to exit the input mode.

[Recorder's ID Data Setting]

Rom Write OK !

<CLEAR> Exit

[How to Confirm the ID Number]

- ① Press **[ESC]**+**[STEREO]** keys sequentially with an ID number already set, and the unit enters the ID number confirmation mode.
- ② The set ID number is displayed on the screen (and on the FL display), permitting you to confirm it.
- ③ To exit this mode, press **[CLEAR]** key.

```

[Recorder's ID Number Setting]
ID Number ?
[ 0 0 0 0 0 0 0 1]
Compare
> *****
② →
③ → <CLEAR> Exit
      <STEREO> ID Data Setting Mode
      Input ID Number !
  
```

[How to Clear the ID Number]

- ① Press **[ESC]**+**[STEREO]** keys sequentially with an ID number already set, and the unit enters the ID number confirmation mode.
- ② Input the same number as the ID number you have set.

```

[Recorder's ID Number Setting]
ID Number ?
[ 0 0 0 0 0 0 0 1]
Compare
> *****
② →
      <CLEAR> Exit
      <STEREO> ID Data Setting Mode
      Input ID Number !
  
```

- ③ After inputting the number, press **[STOP]** key.
Only when the entered number matches the set ID number, the ID number is cleared and the unit exits this mode.
If the numbers do not match, you must return to step ②.
(**[STOP]** key is not accepted until 9 digits are entered.)

```

[Recorder's ID Number Setting]
ID Number ?
[ 0 0 0 0 0 0 0 1]
Compare
> 0 0 0 0 0 0 0 1 OK ?
③ → <PLAY> Enter
      <STOP> Memory Clear
      <STEREO> ID Data Setting Mode
      Input ID Number !
  
```

8.4 FIRMWARE UPDATE METHOD

[Purposes]

1. When the main board is replaced, the firmware versions for the system control computer, drive, and the TUFL microcomputer do not match, and operations of the unit may be destabilized.
To match the versions for the above three, firmware downloading is necessary in the following two cases:
 - ① After the model setting
 - ② When NG is displayed on the first screen (version information, etc.) of Service mode
 - ③ After changing MAIN Assy or TUSB Assy
2. Rewriting the firmware to the latest version may ameliorate the symptoms claimed by the customer.

There are the following two methods for update: disc update and serial update

◆ Disc Update

[Tools to be used]



Remote control unit
for servicing
(GGF1381)



Update DISC

[Notes]

Be sure NOT to turn off the unit during update.
If the unit is turned off during update, the SYSCON, TUNERCON, DRIVE programs may not be properly rewritten, in which case the unit may not be able to initialize itself normally when turned on again.

- #### [Procedure]
- ① Open a disc tray by pressing the "OPEN/CLOSE" button.
 - ② Put the update disc on the tray. Press a " OPEN/CLOSE " button while pressing a "Record Stop" button on the frontpanel.
 - * The disc tray closes automatically and the disc is loaded.
 - * The disc tray opens automatically after loading.

FL display

LOAD



DISC D W L D

- ③ Take out the Download Disc.



DOWNLOAD - 2 SYSCON download



DOWNLOAD - 3

FrontEnd
download



DOWNLOAD - 4

TunerCon
download

- * After update is completed, the power turns off, and a disc tray closes automatically.
- * It takes for about 7-8 minutes until update is completed.

- A
- ④ The power turns on and press a " ESC " button, then press " DISP " button on the remote control unit for servicing.
 - ⑤ Confirm a firmware release version.
 - ⑥ Press " ESC " button on the remote control unit for servicing in order to exit the test mode.

[Tips]

- (1) If the power is not correctly turned on or when the power is shut off during update, proceed as follows before performing update again:
- In a case where update was incorrectly terminated while "DOWNLOAD-2" was displayed on the FL display:
The SYSCON program will not function correctly.
If the program cannot be update from the disc or through serial communication, replace the MAIN Assy.
 - In a case where update was incorrectly terminated while "DOWNLOAD-3" was displayed on the FL display:
The DRIVE program will not function correctly.
If the program cannot be update from the disc, replace the MAIN Assy.
 - In a case where update was incorrectly terminated while "DOWNLOAD-4" was displayed on the FL display
The program for the tuner microcomputer will not function correctly.
If the program cannot be update from the disc, replace the TUNERCON microcomputer (IC101 : TUSB Assy).
- B
- C

◆ Serial Update

[Purposes]

1. This method is used when disc update fails.

[Tools to be used]

- * PC with serial port
- * RS-232C straight cable
- * RS-232C I/F jig (GGF1348)
- * 7P FFC (VDA1681)
- * Update program (UFU.exe)
- * Firmware

[Connection]

Connect as follows:

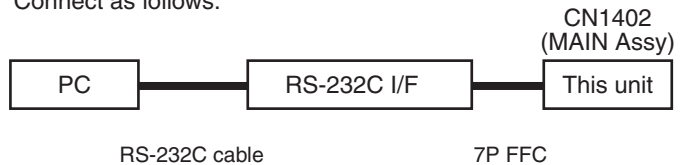

[Procedures]

- ① Connect the 232C I/F jigs above way.
- ② Turn on the PC and start the "UFU.exe".
- ③ Select the Firmware file. ("sz0" file)
- ④ Turn the DVD recorder on and start the update program.
"Target Device is connected" is appeared on the screen.
- ⑤ Select the Communication Speed (Baud Rate)
 - a) Base Speed 115,200
 - b) Data Send Speed 115,200
- ⑥ START
 - Even if you click "START" button, sometimes "Communication Error" may come out one to twice, and update may fail. In this case, please click "START" again.
 - Other factors can be considered if update fails 3 times or more.
 - And it takes about 20 minutes for updating the firmware.

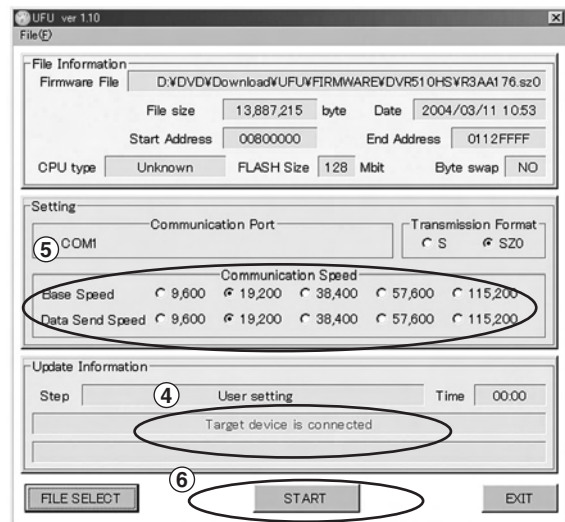
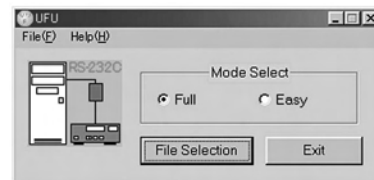

8.5 VIDEO ADJUSTMENT FOR SPECIFIC AREA

[Purposes]

Depending on the area, if a flicker may appear in a picture received by the tuner, it can be corrected or reduced with this setting.

[Tools to be used]

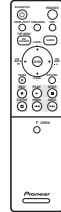

Remote control unit supplied with the unit (VXX3222)

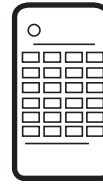

Remote control unit for servicing (GGF1381)

◆ Specific-Channel Setting Mode

In this mode, specific settings can be made for up to 12 channels.

For channels that do not have specific settings, the settings of General Setting mode are applied.

[How to enter this mode]

- ① Select a channel or line input (L1-L3) on which a specific setting is to be made.
- ② Press the **[ESC]** then **[CHP/TIM]** keys on the remote control unit for servicing. "General Setting mode" is displayed.
- ③ Press the **[DIG/ANA]** key in General Setting mode. Specific-Channel Setting mode is entered.

[How to exit] Press the **[ESC]** key on the remote control unit for servicing to return the Normal mode.

[Note] Setting is in effect only during recording/playback stop.

[Setting examples]

The setting examples in Specific-Channel Setting mode are shown below.

For details on each setting item, see "Table 1: Key operations in Specific-Area Setting mode."

[When specific channel setting have NOT been made]

General setting data	Specific Area Mode		
	Input - [TUNER]		
	Sync AGC	: ON	*
	H Threshold Level	: 12	*
	V Threshold Level	: 10	*
	EPG EQ	: OFF	*
Specific channel setting data	Individual setting state		
	Input Channel - [1CH]		
	Sync AGC	: ---	
	H Threshold Level	: -----	
	V Threshold Level	: ---	

[When specific channel setting have been made]

Specific Area Mode		
Input - [TUNER]		
Sync AGC	: ON	*
H Threshold Level	: 12	*
V Threshold Level	: 10	*
EPG EQ	: OFF	*
Individual setting state		
Input Channel - [1CH]		
Sync AGC	: ON	*
H Threshold Level	: 14	
V Threshold Level	: 7	

[Tips]

- If a channel that does not have specific settings is displayed, the setting figures are displayed as hyphens (- -).
- If the setting figures are not displayed as hyphens, those settings have been specifically set even if they are identical to the default settings or those of General Setting mode.
- The setting indicated with an asterisk (*) is the default.
- The channels to be indicated for "Input Channel" are as shown below:
Line inputs: L1-L3, DV (DV is not valid for specific-area settings.)
Tuner channels: Channels received by the tuner (channels to be set in Specific-Channel Setting mode, etc.)

[Tips]

- Indication when the maximum number (12) of channels have individual settings
If a channel that does not have specific settings is currently selected, the indication will be as shown below, and individual data items cannot be set for that channel. To set individual data items for the currently selected channel, you must clear any specific-channel settings for one or more channels.

Specific Area Mode

```

Input - [ TUNER ]
Sync AGC      : ON      *
H Threshold Level : 12   *
V Threshold Level : 10   *

EPG EQ       : OFF     *
  
```

Individual setting state

Sorry !
You can store only 12 channels
for Specific Area mode.

[H Threshold Level]

The slice level setting for the horizontal(H)-sync separation circuit can be changed. By your changing the slice level, horizontal sync disturbance may be ameliorated. Set the slice level to a value with which the least sync disturbance is seen.

[V Threshold Level]

The slice level setting for the vertical(V)-sync separation circuit can be changed. By your changing the slice level, vertical sync disturbance may be ameliorated. Set the slice level to a value with which the least sync disturbance is seen.

[Receiver sensitivity setting for an electronic program guide (EPG)]

The sensitivity when receiving an electronic program guide can be selected. Set the sensitivity to "High" only if reception is unstable.

◆ General Setting Mode**[How to enter this mode]**

- To shift from Specific-Channel Setting mode:
Each time the **[DIG/ANA]** key is pressed, Specific-Channel Setting mode and General Setting mode are alternately selected.
- To shift from Normal mode (recording/playback stop):
Press the **[ESC]** then **[CHP/TIM]** keys.

[How to exit] Press the **[ESC]** key to return the normal mode.

[Setting examples]

Show setting example on the General Setting mode screen to the following.
Regarding setting of actual each item, refer to table 1 (key operations in specific-area setting mode).

[General Setting mode screen]

```

Specific Area Mode
Input - [ TUNER ]
Sync AGC      : ON      *
H ThresholdLevel : 12   *
V Threshold Level : 10   *

EPG EQ       : OFF     *
  
```

*: Setting is the default.

[Display in General Setting mode when the channel currently displayed has specific settings]

```

Specific Area Mode
Input - [ TUNER ]
Sync AGC      : ON      *
H ThresholdLevel : 12   *
V Threshold Level : 10   *

EPG EQ       : OFF     *
  
```

This channel is set up
individually.

[Tips]

- General Setting mode can be entered only during recording/playback stop.
- The currently selected input mode (TUNER or LINE) is displayed for "Input."
- If L1, L2, L3, or DV is selected for input, general settings for the line input can be made (DV is not valid for specific-area settings), and if TUNER is selected, general settings for the tuner input can be made.

Table 1: key operations in specific-Area setting mode (1/2)

Key operations in Specific Area Setting mode of the remote control units are shown in the table below (the keys are of the remote control unit for servicing unless otherwise stated):

Key	Operation	Switching (*: Default)	Remarks	Used in Specific-Channel Setting mode	Used in General Setting mode
[DIG/ANA]	Switches General setting mode and Specific setting mode.	-	-	<input type="radio"/>	<input type="radio"/>
[INPUT SELECT], [CHANNEL +/-] (Remote control unit supplied with this unit)	Switches inputs or channels.	-	-	<input type="radio"/>	<input type="radio"/>
[SIDE A], [SIDE B]	Sets SyncAGC.	ON(*) / OFF	ON : The sync level is set to an appropriate value. OFF : Cancel the Sync AGC.	<input type="radio"/>	<input type="radio"/>
[Rev x3], [x3 Fwd]	Sets H Threshold.	0 – 15 (Default : 12)	[Rev x3] : Decreasing 1 by 1 in the range 0 to 15. (Cyclic operation) [x3 Fwd] : Increasing 1 by 1 in the range 0 to 15. (Cyclic operation)	<input type="radio"/>	<input type="radio"/>
[Rev CHAPTER SKIP] [CHAPTER SKIP Fwd]	Sets V Threshold Level.	0 – 15 (Default : 10)	[Rev CHAPTER SKIP] : Decreasing 1 by 1 in the range 0 to 15. (Cyclic operation) [CHAPTER SKIP Fwd] : Increasing 1 by 1 in the range 0 to 15. (Cyclic operation)	<input type="radio"/>	<input type="radio"/>



Table 1 : key operations in specific-Area setting mode (2/2)

Key	Operation	Switching (*: Default)	Remarks	Used in Specific-Channel Setting mode	Used in General Setting mode
[PLAY]	All channels that have specific setting data will be canceled, and the specific data will be initialized.	-	The General Setting data will not be changed.	<input type="radio"/>	<input checked="" type="checkbox"/>
[CLEAR]	Specific-Channel Setting mode: If the currently selected channel has its specific setting, that setting will be canceled. (By canceling the specific setting for that channel, the number of remaining channels that can have specific settings will be increased by one.) General Setting mode: Settings of General Setting mode are initialized.	-	Specific-Channel Setting mode: All specific data are initialized. The General Setting data will not be changed. General Setting mode: All general setting data are reset to default. The specific setting data will not be changed (will be retained).	<input type="radio"/>	<input type="checkbox"/>
[PAUSE]	The specific-channel-setting data for the currently selected channel are reset to default.	-	The General Setting data will not be changed (will be retained).	<input type="radio"/>	<input checked="" type="checkbox"/>
[ESC]	To quit Setting mode for a specific area and clear the on-screen display.	-	-	<input type="radio"/>	<input type="checkbox"/>

Notes:

- Each key listed in Table 1 above is active only while the tuner is completely stopped.
- The setting values will not be reset to default even if resetting to the state at the time of shipment is performed.

9. EXPLODED VIEWS AND PARTS LIST

- NOTES:**
- Parts marked by "NSP" are generally unavailable because they are not in our Master Spare Parts List.
 - The  mark found on some component parts indicates the importance of the safety factor of the part. Therefore, when replacing, be sure to use parts of identical designation.
 - Screws adjacent to  mark on product are used for disassembly.
 - For the applying amount of lubricants or glue, follow the instructions in this manual. (In the case of no amount instructions, apply as you think it appropriate.)

9.1 PACKING

DVR-LX60/YXVRE5
DVR-550H-S/YXVRE5
ONLY

DVR-LX60/WYXV5
DVR-550H-S/WYXV5
ONLY

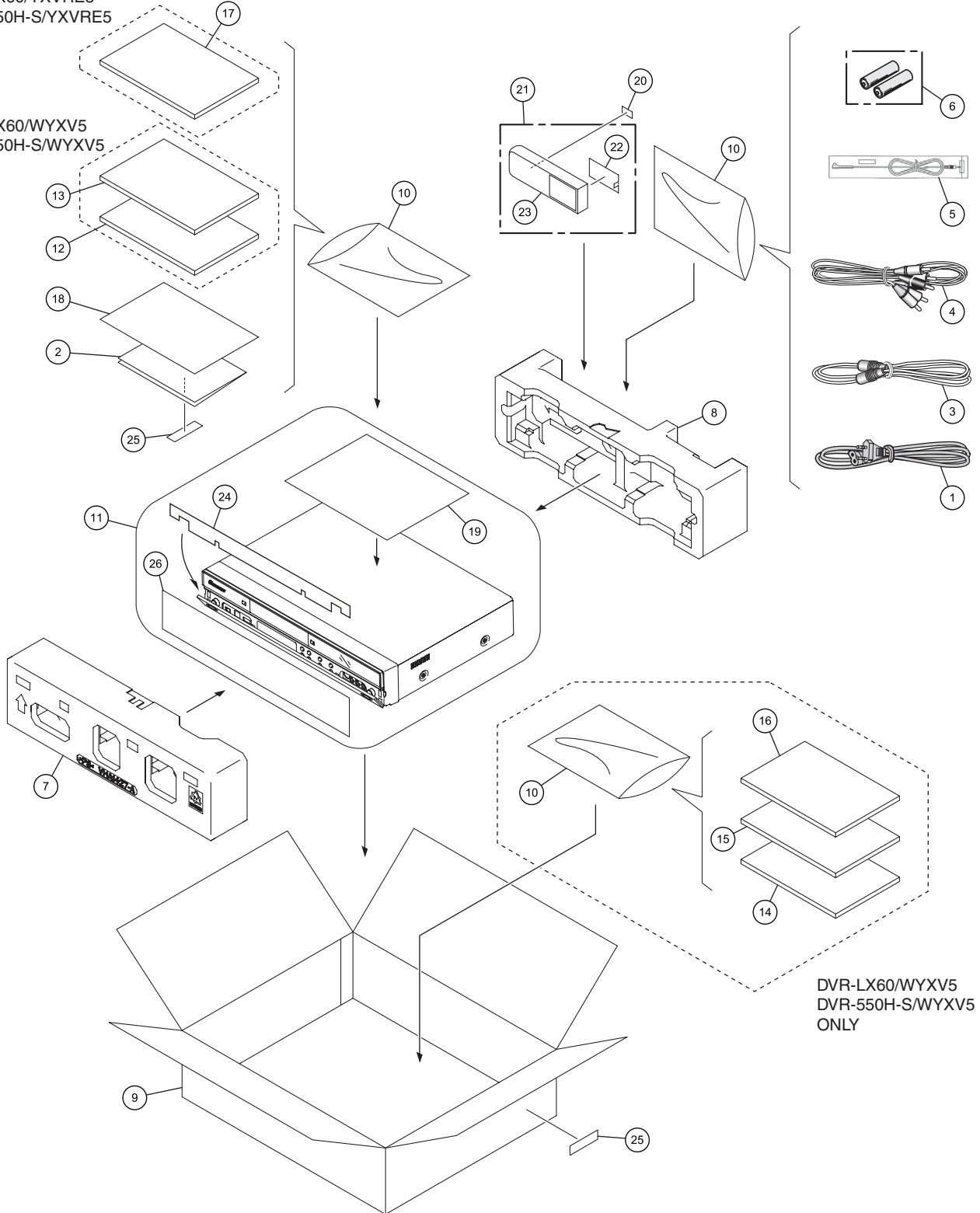

DVR-LX60/WYXV5
DVR-550H-S/WYXV5
ONLY

(1) PACKING SECTION PARTS LIST

<u>Mark No.</u>	<u>Description</u>	<u>Part No.</u>	<u>Mark No.</u>	<u>Description</u>	<u>Part No.</u>
△ 1	Power Cable	ADG1127	14	Operating Instructions (Italian)	See Contrast table (2)
NSP 2	Warranty Card	ARY7065	15	Operating Instructions (Dutch)	See Contrast table (2)
3	RF Antenna Cable (PAL)	VDE1075	16	Operating Instructions (Spanish)	See Contrast table (2)
4	Audio / Video Cable (1.5m) (red/white/yellow)	VDE1077	17	Operating Instructions (Russian)	See Contrast table (2)
5	G-Link Cable (3m)	VDX1010	18	HDD Caution 8L	VRR1071
NSP 6	Dry Cell Batteries (AA/R6P)	See Contrast table (2)	19	HDD Caution 8L B	VRR1076
7	Front Pad	VHA1427	20	WEEE Label	See Contrast table (2)
8	Rear Pad	VHA1428	21	Remote Control	See Contrast table (2)
9	Packing Case	See Contrast table (2)	22	Battery Cover	See Contrast table (2)
10	Polyethylene Bag	VHL1088	23	Top Cover	See Contrast table (2)
11	Mirror Sheet	VHL1095	24	Sheet	See Contrast table (2)
12	Operating Instructions (French)	See Contrast table (2)	NSP 25	Serial Label S	VRW2188
13	Operating Instructions (German)	See Contrast table (2)	26	Nonwoven Cloth Cover	See Contrast table (2)

(2) CONTRAST TABLE

DVR-LX60/WYXV5, DVR-LX60/YXVRE5, DVR-550H-S/WYXV5, DVR-550H-S/YXVRE5 and DVR-550H-AV/WYXV5 are constructed the same except for the following :

<u>Mark</u>	<u>No.</u>	<u>Symbol and Description</u>	<u>DVR-LX60/ WYXV5</u>	<u>DVR-LX60/ YXVRE5</u>	<u>DVR-550H-S/ WYXV5</u>	<u>DVR-550H-S/ YXVRE5</u>	<u>DVR-550H-AV/ WYXV5</u>
NSP	6	Dry Cell Batteries (AA/R6P)	VEM1010	VEM1010	VEM1010	VEM1010	Not used
	9	Packing Case	VHG2794	VHG2822	VHG2788	VHG2821	VHG2816
	12	Operating Instructions (French)	VRC1381	Not used	VRC1380	Not used	Not used
	13	Operating Instructions (German)	VRC1386	Not used	VRC1385	Not used	Not used
	14	Operating Instructions (Italian)	VRC1390	Not used	VRC1389	Not used	Not used
	15	Operating Instructions (Dutch)	VRC1394	Not used	VRC1393	Not used	Not used
	16	Operating Instructions (Spanish)	VRC1398	Not used	VRC1397	Not used	Not used
	17	Operating Instructions (Russian)	Not used	VRC1401	Not used	VRC1400	Not used
	20	WEEE Label	VRW2231	VRW2231	VRW2231	VRW2231	Not used
	21	Remote Control	VXX3222	VXX3222	VXX3246	VXX3246	Not used
	22	Battery Cover	VZN1017	VZN1017	VZN1004	VZN1004	Not used
	23	Top Cover	VZN1018	VZN1018	VZN1021	VZN1021	Not used
	24	Sheet	Not used	Not used	VHL1117	VHL1117	VHL1117
	26	Nonwoven Cloth Cover	VHL1116	VHL1116	Not used	Not used	Not used

9.2 EXTERIOR SECTION

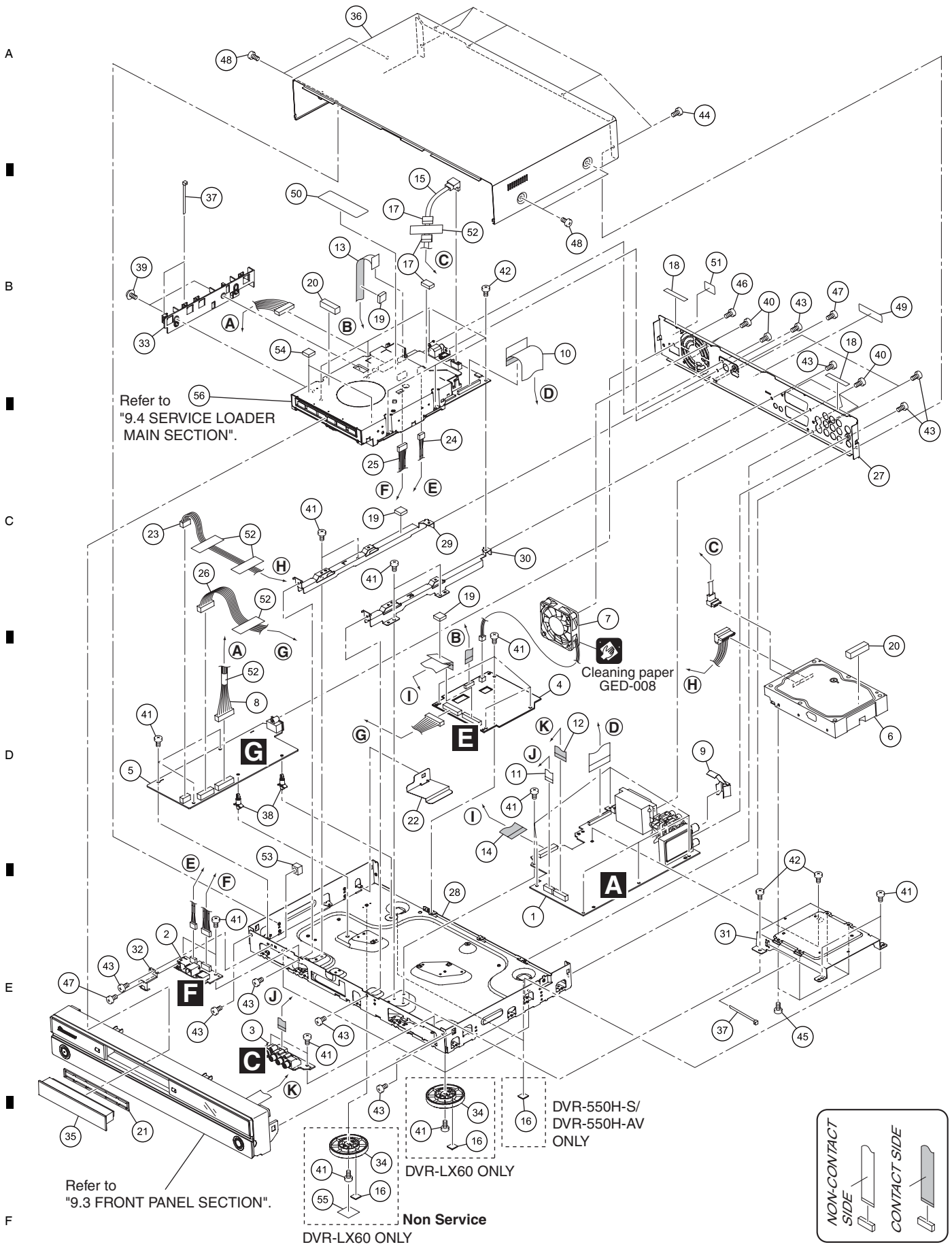

(1) EXTERIOR SECTION PARTS LIST

<u>Mark No.</u>	<u>Description</u>	<u>Part No.</u>	<u>Mark No.</u>	<u>Description</u>	<u>Part No.</u>
1	SERVICE TUSB Assy	VXX3230	NSP 31	HDD Stay	VNE2450
2	SERVICE DVUB Assy	See Contrast table (2)	32	DV Angle	VNE2453
3	SERVICE FRJB Assy	VXX3227	33	Cord Holder	VNL1971
4	VDEC Assy	VWV2304	34	Insulator	See Contrast table (2)
△ 5	POWER SUPPLY Assy	VWR1406	35	Tray Panel	VXA2866
6	HDD	See Contrast table (2)	36	Bonnet Case S	See Contrast table (2)
7	DC Fan Motor 60	VXM1125	NSP 37	Binder (BK-1)	ZCA-BK1
8	Connector Assy	PF13PP-S17	38	PCB Support	AEC1215
9	Eath Plate TU	VBK1173	39	Screw	AMZ30P060FTC
10	Flexible Cable 40P	VDA2159	40	Screw	BPZ30P080FTC
11	Flexible Cable 11P	VDA2162	41	Screw	BSR30P060FTC
12	Flexible Cable 17P	VDA2163	42	Screw	BSR30P080FTB
13	Flexible Cable 28P	VDA2164	43	Screw	BSZ30P040FTC
14	Flexible Cable 24P	VDA2165	44	Screw	See Contrast table (2)
15	SATA Cable	VDX1016	45	Screw #6-32	DBA1125
16	Rubber Foot	VEB1349	46	Screw	PBZ30P080FTC
17	Rubber Spacer	VEB1378	47	Screw	VBA1088
18	Cushion	VEB1401	48	Screw	See Contrast table (2)
19	Rubber Spacer	VEB1398	NSP 49	Serial Label S	VRW2188
20	Gasket 30x10T	VEC2522	50	Laser Caution Label	VRW2262
21	Tray Sheet	VEC2551	NSP 51	ID Label Assy	VXW1015
22	Barrier	See Contrast table (2)	NSP 52	Tape	ZTA-3800A-12
23	Housing Assy 4P	VKP2389	53	Screw Guard	VEB1399
24	Housing Assy 6P	VKP2390	54	Spacer Cushion	VEB1400
25	Housing Assy 10P	See Contrast table (2)	55	Insulator Sheet	See Contrast table (2)
26	Housing Assy 12P	VKP2397	NSP 56	Service Loader Main	See Contrast table (2)
27	Rear Panel	See Contrast table (2)			
NSP 28	Base Chassis	VNB1057			
NSP 29	Writer Stay L	VNE2448			
NSP 30	Writer Stay R	VNE2449			

(2) CONTRAST TABLE

DVR-LX60/WYXV5, DVR-LX60/YXVRE5, DVR-550H-S/WYXV5, DVR-550H-S/YXVRE5 and DVR-550H-AV/WYXV5 are constructed the same except for the following :

Mark	No.	Symbol and Description	DVR-LX60/ WYXV5	DVR-LX60/ YXVRE5	DVR-550H-S/ WYXV5	DVR-550H-S/ YXVRE5	DVR-550H-AV/ WYXV5
	2	SERVICE DVUB Assy	VXX3231	VXX3231	VXX3232	VXX3232	VXX3232
	6	HDD	VXF1131	VXF1131	VXF1137	VXF1137	VXF1137
	22	Barrier	VEC2548	VEC2548	Not used	Not used	Not used
	25	Housing Assy 10P	VKP2391	VKP2391	Not used	Not used	Not used
	27	Rear Panel	VNA3004	VNA3006	VNA3019	VNA3007	VNA3003
	34	Insulator	VNK6208	VNK6208	Not used	Not used	Not used
	36	Bonnet Case S	VXX3243	VXX3243	VXX3238	VXX3238	VXX3238
	44	Screw	BSZ30P060FBN	BSZ30P060FBN	BSZ30P040FTC	BSZ30P040FTC	BSZ30P040FTC
	48	Screw	VBA1112	VBA1112	BSZ30P040FTC	BSZ30P040FTC	BSZ30P040FTC
	55	Insulator Sheet	VEC2572	VEC2572	Not used	Not used	Not used
NSP	56	Service Loader Main	VXU1010	VXU1010	VXU1009	VXU1009	VXU1009

9.3 FRONT PANEL SECTION

9.3.1 For DVR-LX60

A

B

C

D

E

F

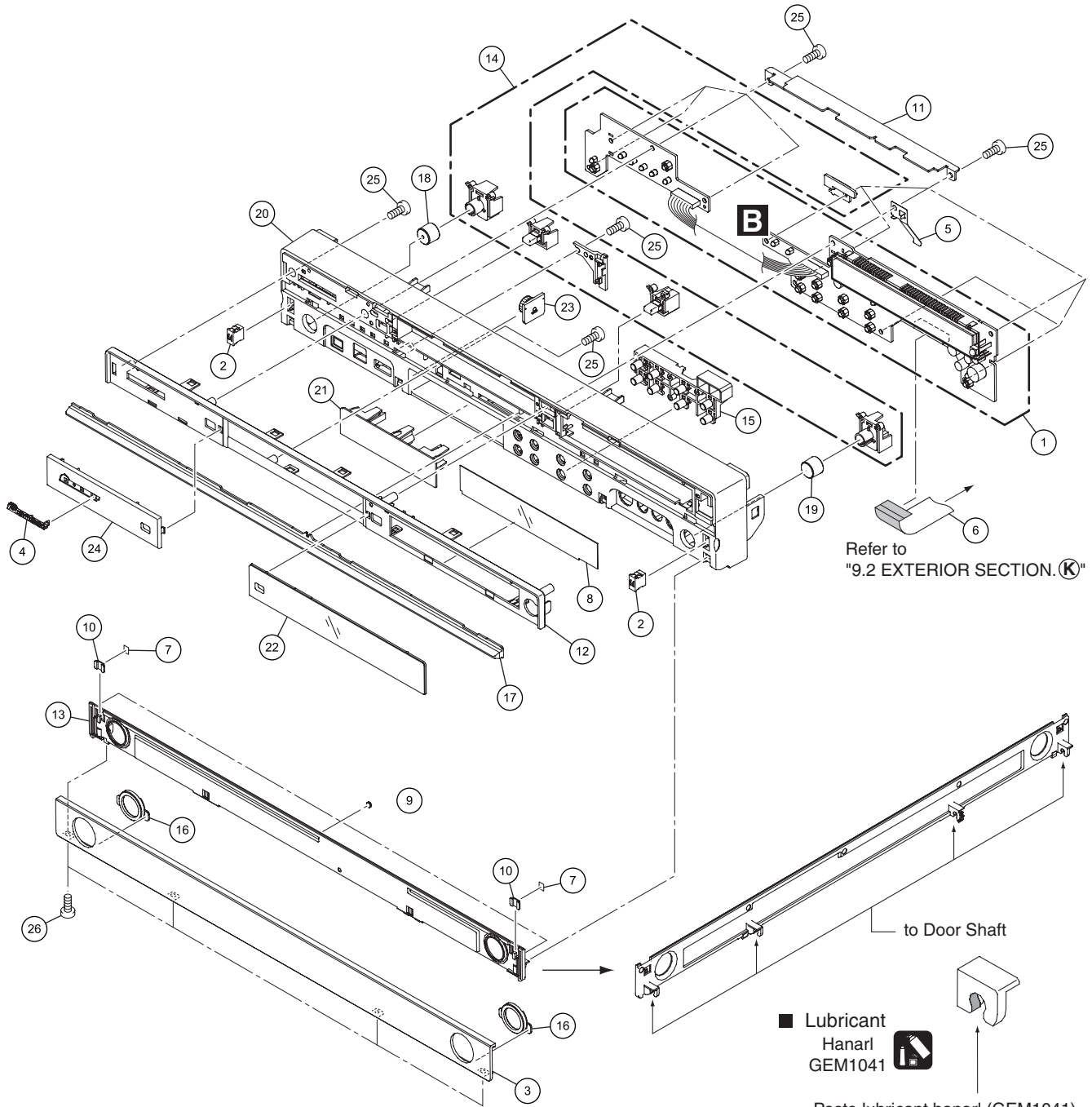

Refer to
"9.2 EXTERIOR SECTION. (K)"

■ Lubricant
Hanarl
GEM1041

Paste lubricant hanarl (GEM1041)
to salient points of both sides of the
door.

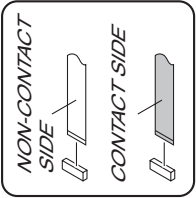

5 6 7 8

(1) FRONT PANEL SECTION PARTS LIST

<u>Mark No.</u>	<u>Description</u>	<u>Part No.</u>
1	SERVICE FLKY Assy	VXX3259
2	Magnet Holder Assy	AEC1077
3	Door Panel	VAH1436
4	PIONEER Badge	VAM1158
5	Earth Plate FLKY	VBK1176
6	Flexible Cable 17P	VDA2163
7	Black Spacer	VEC2491
8	FL Filter	VEC2544
9	Door Pad	VEC2562
10	Magnet Catcher	VNE2388
11	FP Bridge	VNE2464
12	Panel Frame	VNK6149
13	Door Base	VNK6161
14	Main Key	VNK6162
15	Function Key	VNK6164
16	Door Ring	VNK6165
17	Center Lens	VNK6168
18	Key Top PW	VNK6181
19	Key Top REC	VNK6183
20	Front Panel	VNK6222
21	CI Cover	VNK6229
22	FL Lens	VNK6252
23	Damper Assy	VXA2858
24	Sub Panel	VXA2865
25	Screw	BPZ30P080FTC
26	Flat Head Screw	VBA1113

A

B

C

D

E

F

9.3.2 For DVR-550H-S and DVR-550H-AV

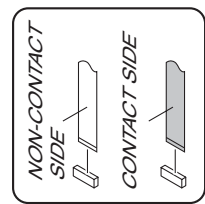
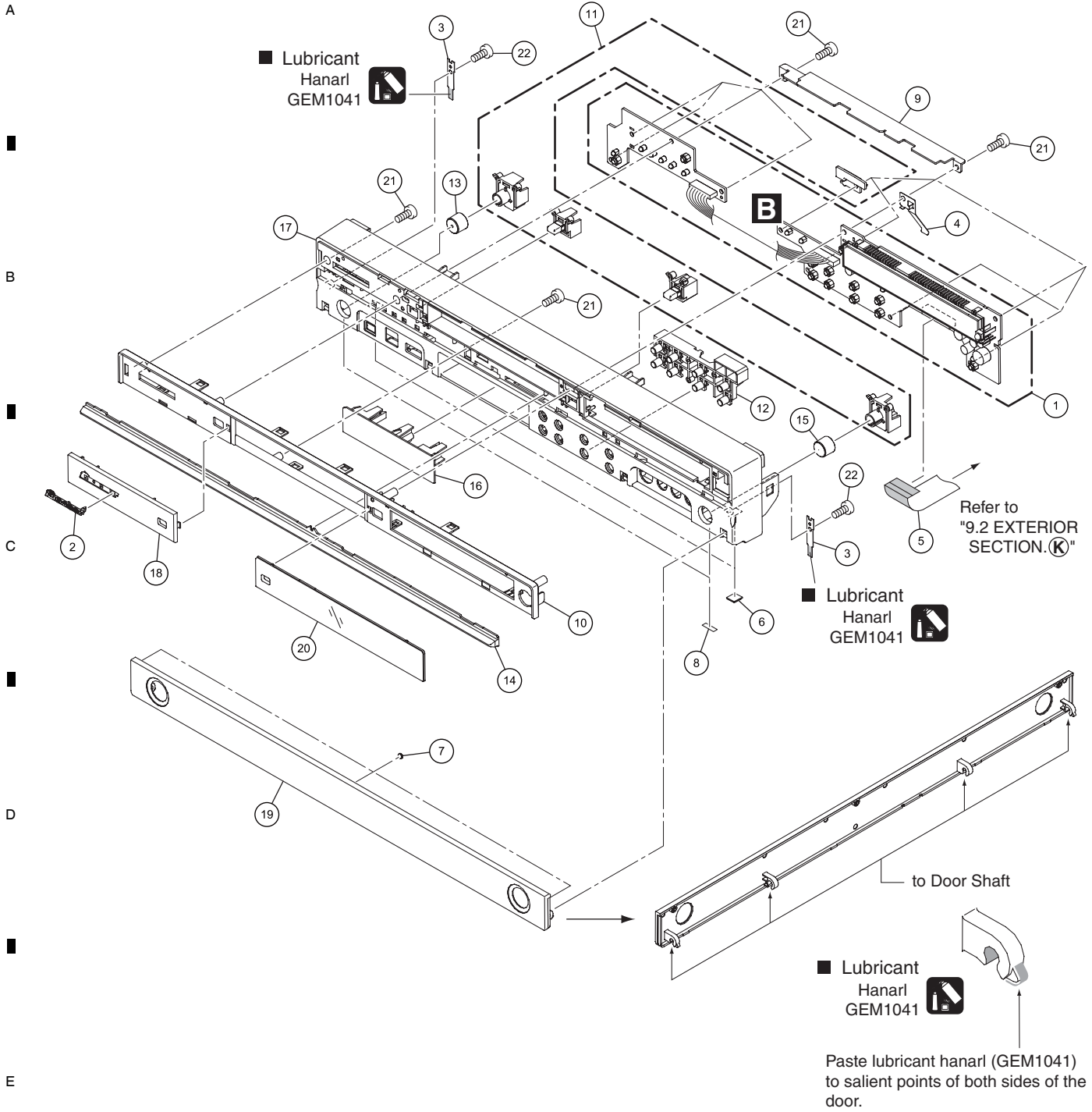

5 6 7 8

(1) FRONT PANEL SECTION PARTS LIST

<u>Mark No.</u>	<u>Description</u>	<u>Part No.</u>
1	SERVICE FLKY Assy	VXX3226
2	PIONEER Badge	VAM1148
3	Door Spring	VBK1175
4	Earth Plate FLKY	VBK1176
5	Flexible Cable 17P	VDA2163
6	Rubber Foot	VEB1349
7	Rubber Sheet	VEB1396
8	Door Cushion	VEC2561
9	FP Bridge	VNE2464
10	Panel Frame	VNK6149
11	Main Key	VNK6162
12	Function Key	VNK6163
13	Key Top PW	VNK6166
14	Center Lens	VNK6168
15	Key Top REC	VNK6182
16	CI Cover	VNK6188
17	Front Panel	VNK6220
18	Sub Panel	VXA2865
19	Door	VXA2867
20	FL Lens	VXA2868
21	Screw	BPZ30P080FTC
22	Flat Head Screw	VBA1113

A

B

C

D

E

F

9.4 SERVICE LOADER MAIN SECTION

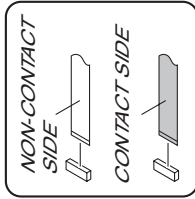

A
B
C
D
E
F

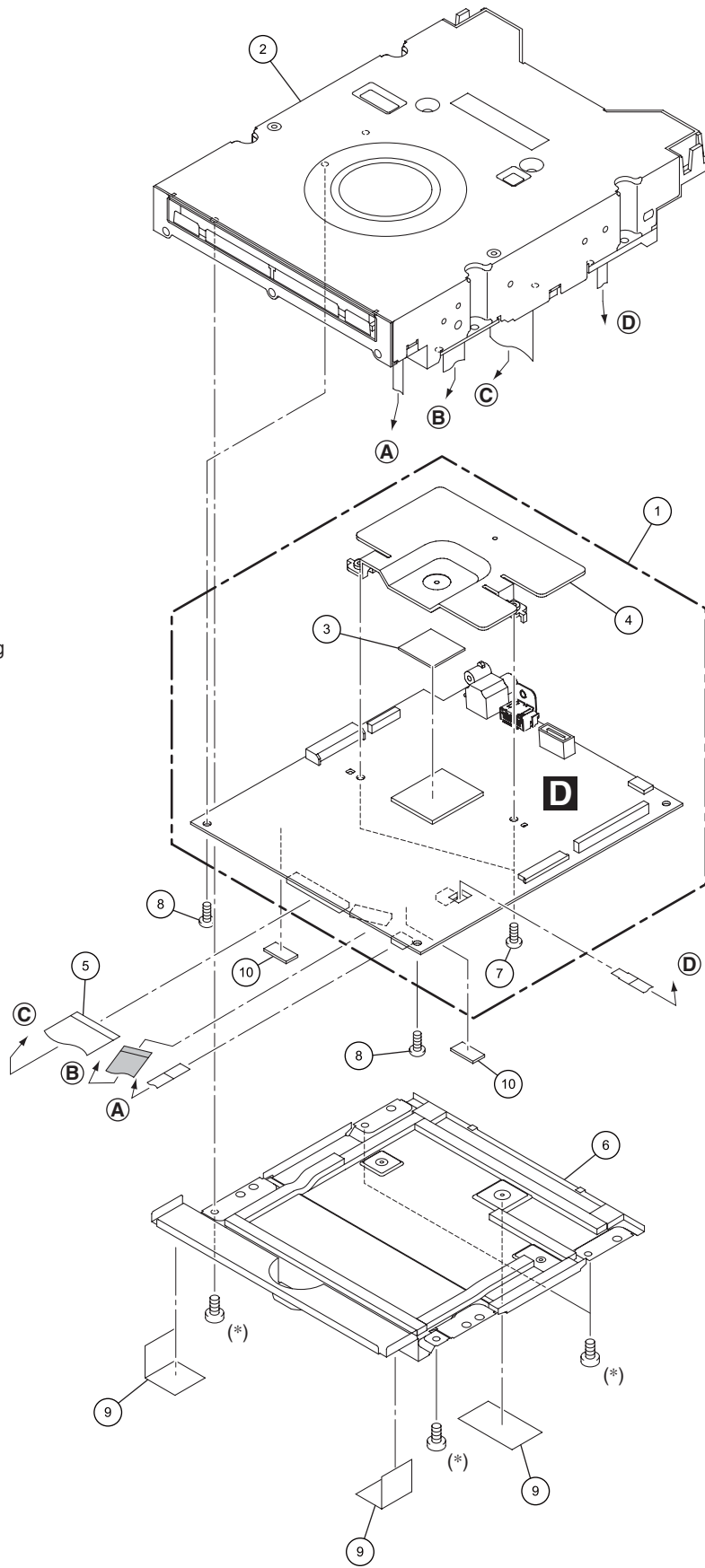

Reuse (*) marked parts when exchanging Service LOADER Assy.
 • Case Screw S (DBA1250) x2

SERVICE LOADER MAIN SECTION PARTS LIST

<u>Mark No.</u>	<u>Description</u>	<u>Part No.</u>	
1	SERVICE MAIN Assy (DVR-LX60)	VXX3241	
1	SERVICE MAIN Assy (DVR-550H-S, DVR-550H-AV)	VXX3240	A
2	Service Loader Assy	VXX3239	
3	Radiation Sheet (Silicon)	VEB1360	
4	Heatsink	VNH1079	
5	FFC U11	DDX1208	
6	Low Case U11	DNC1761	
7	Screw	BBZ30P060FTC	
8	Screw	DBA1220	
NSP 9	Tape	•••••	B
10	Silicon Sheet R9B	DEB1726	

10. SCHEMATIC DIAGRAM

10.1 SERVICE TUSB ASSY (1/4)

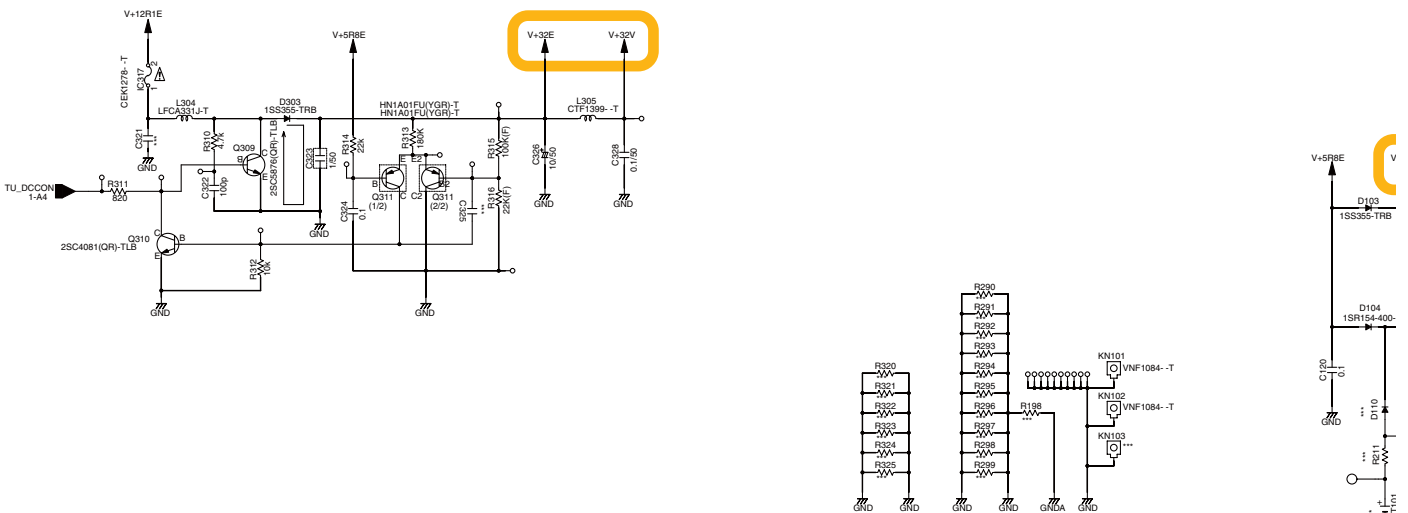
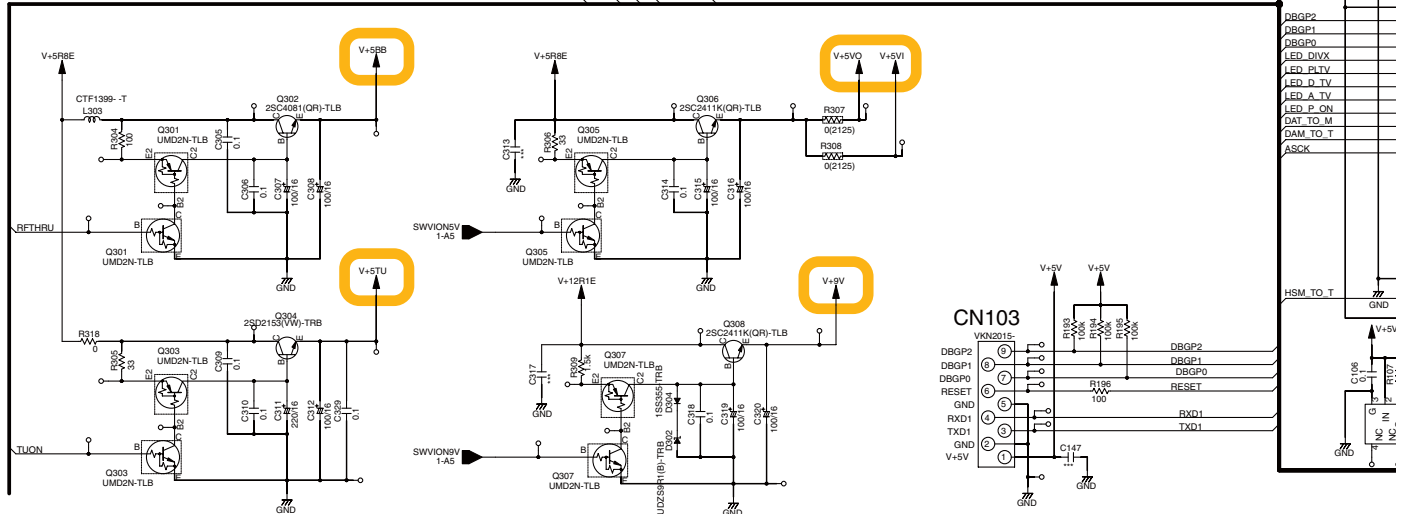
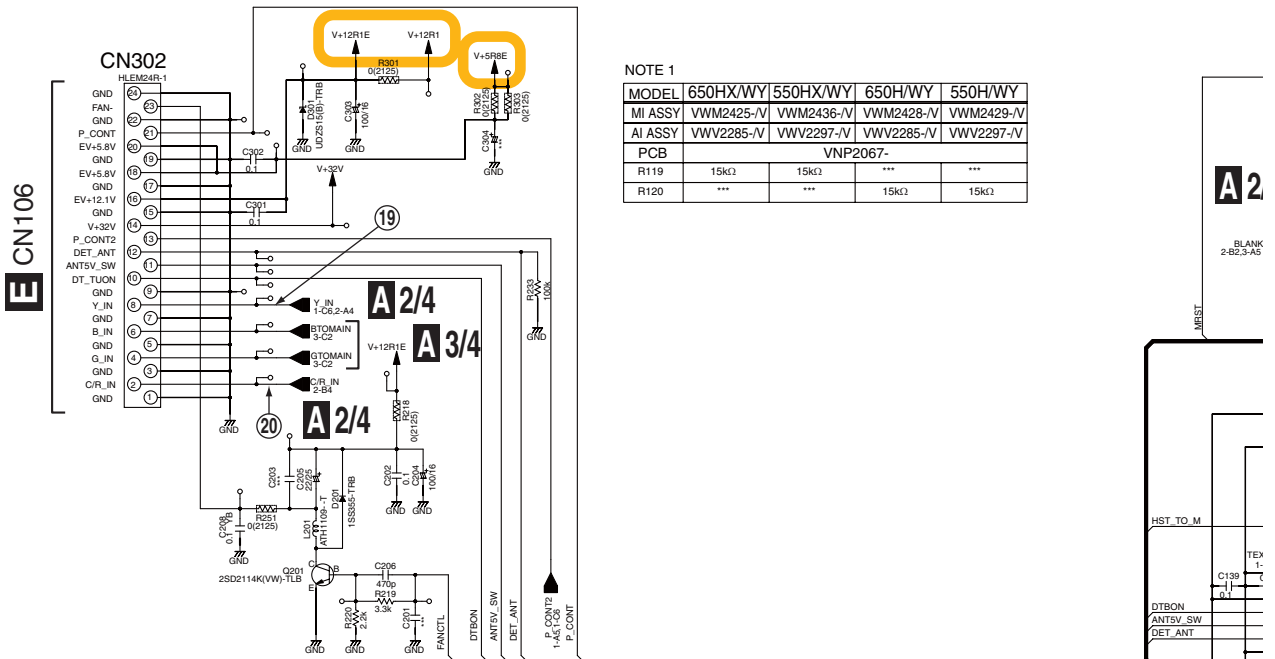

A 1/4 SERVICE TUSB ASSY (1/4) (VXX3230)

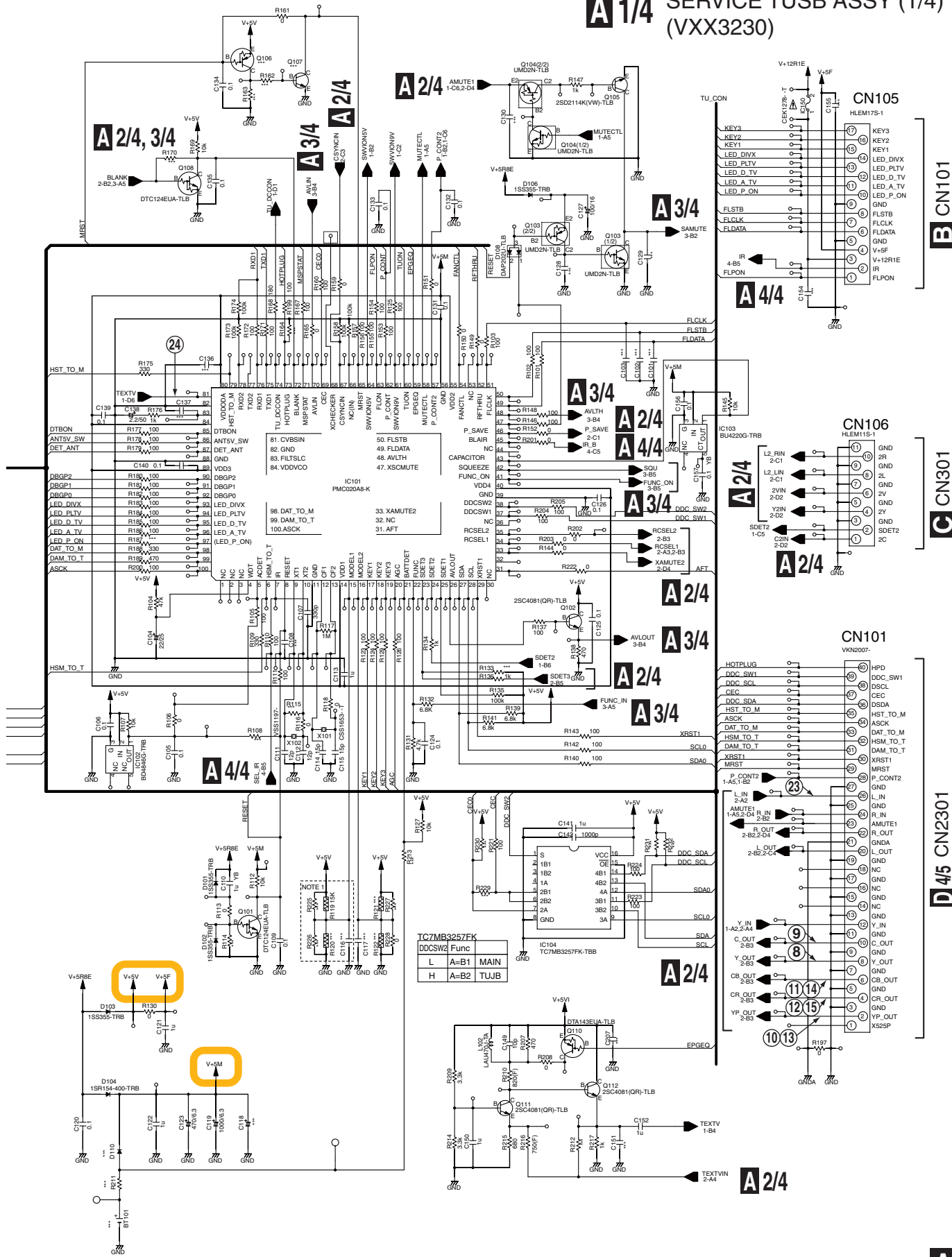

TC7MB3257FK

DDCSW2 Func	
L	A=B1 MAIN
H	A=B2 TUJB

B CN101

C CN301

D 4/5 CN2301

A
B
C
D
E
F

10.2 SERVICE TUSB ASSY (2/4)

A 2/4 SERVICE TUSB ASSY (2/4) (VXX3230)

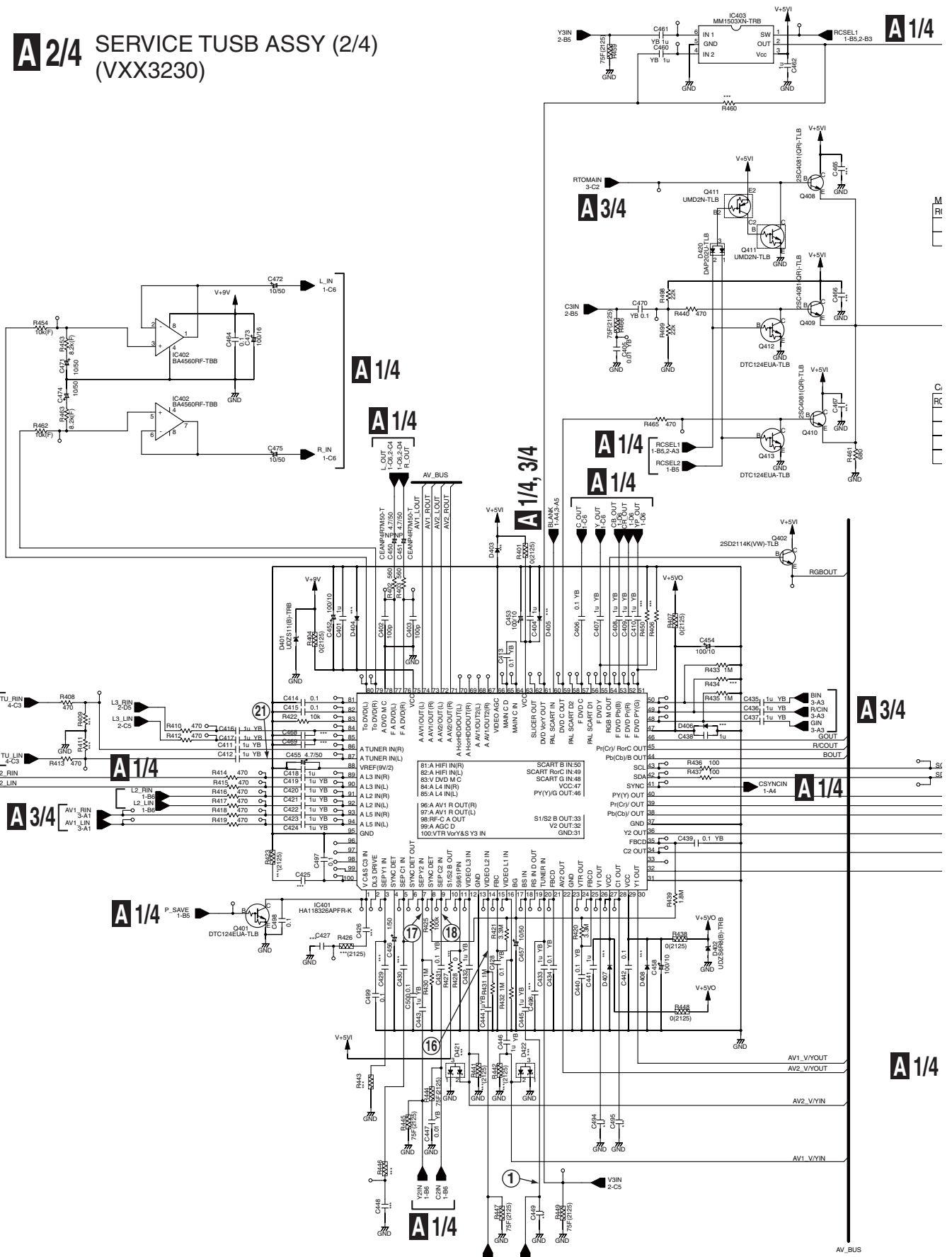

A 2/4

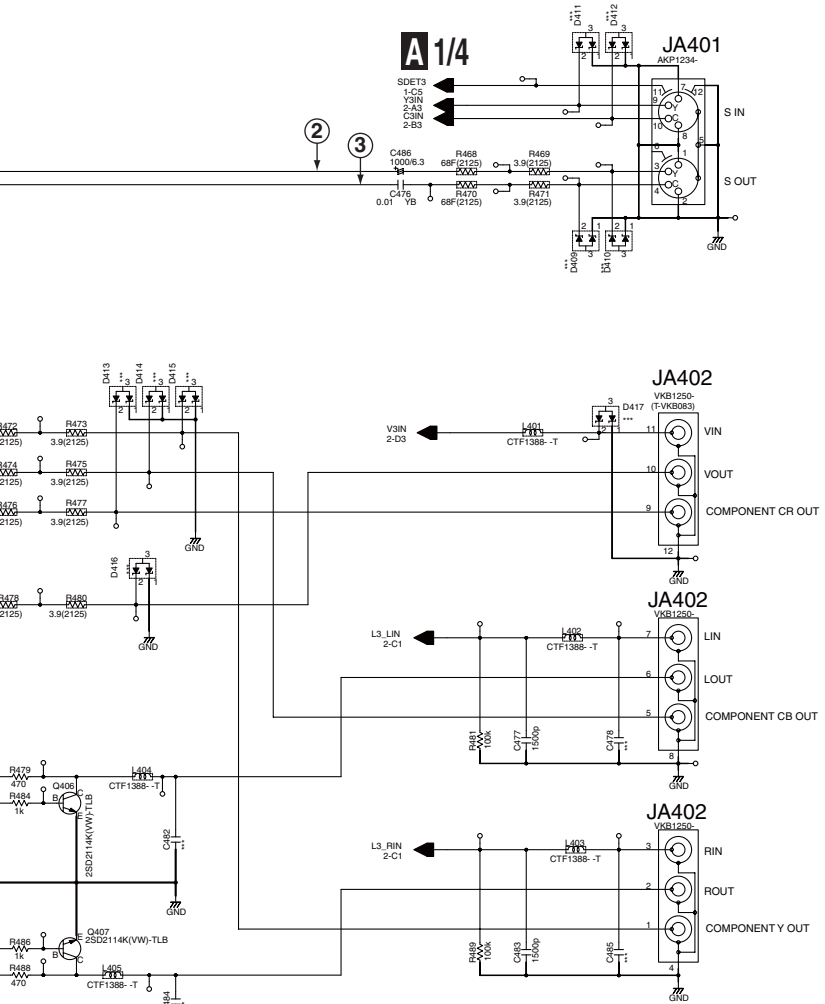
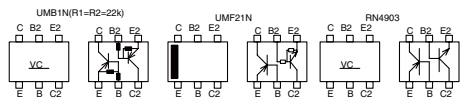
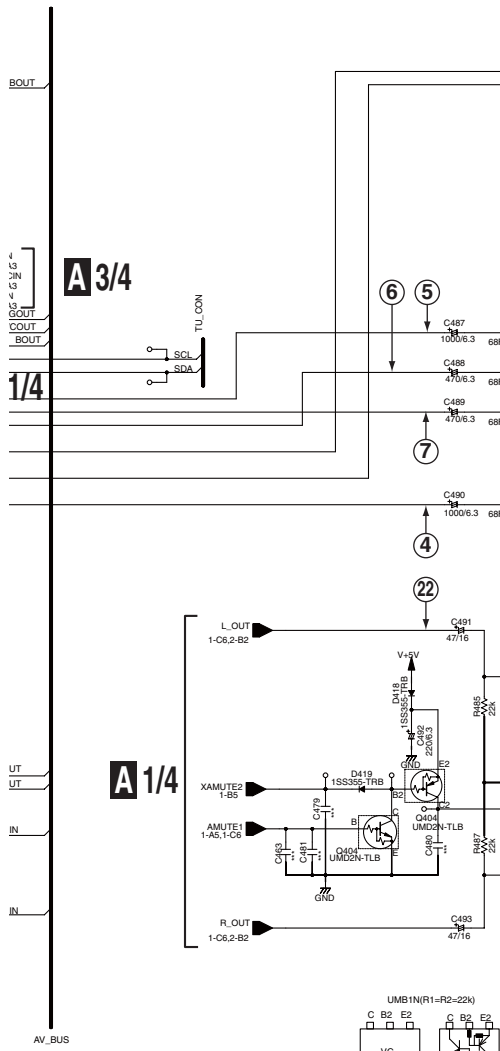
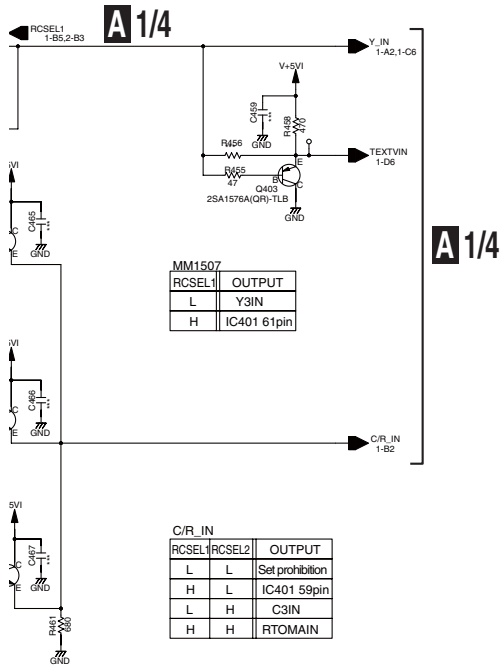

10.3 SERVICE TUSB ASSY (3/4)

A 3/4 SERVICE TUSB ASSY (3/4) (VXX3230)

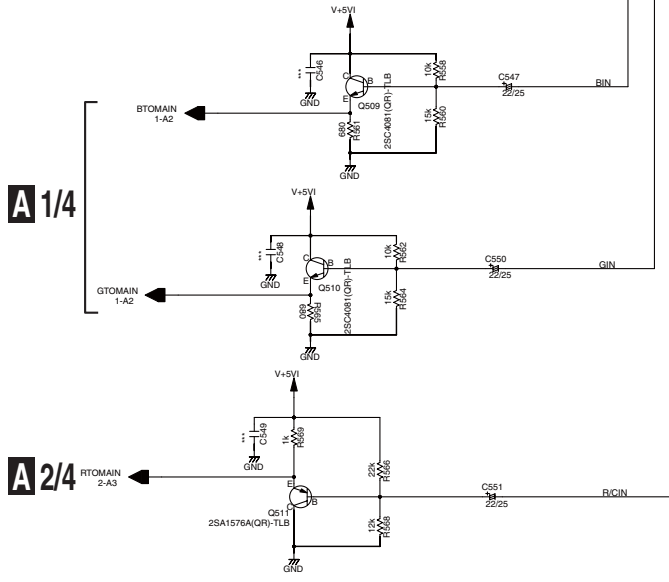
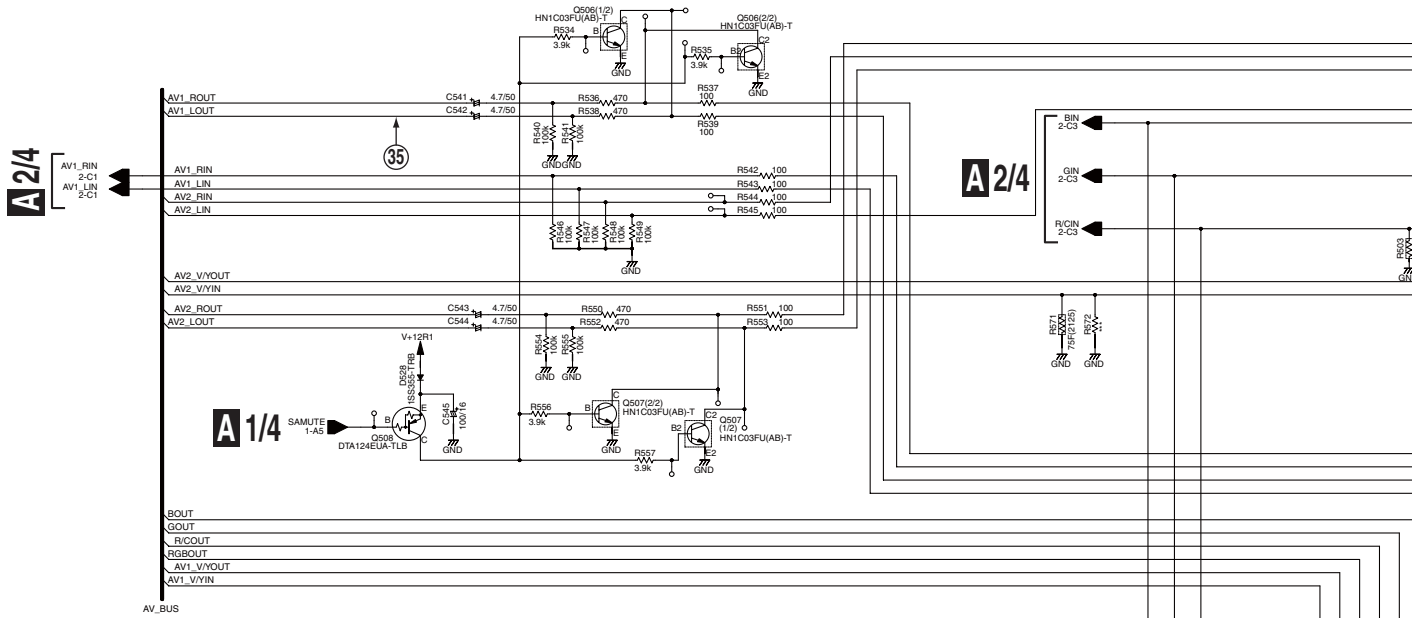

A 3/4

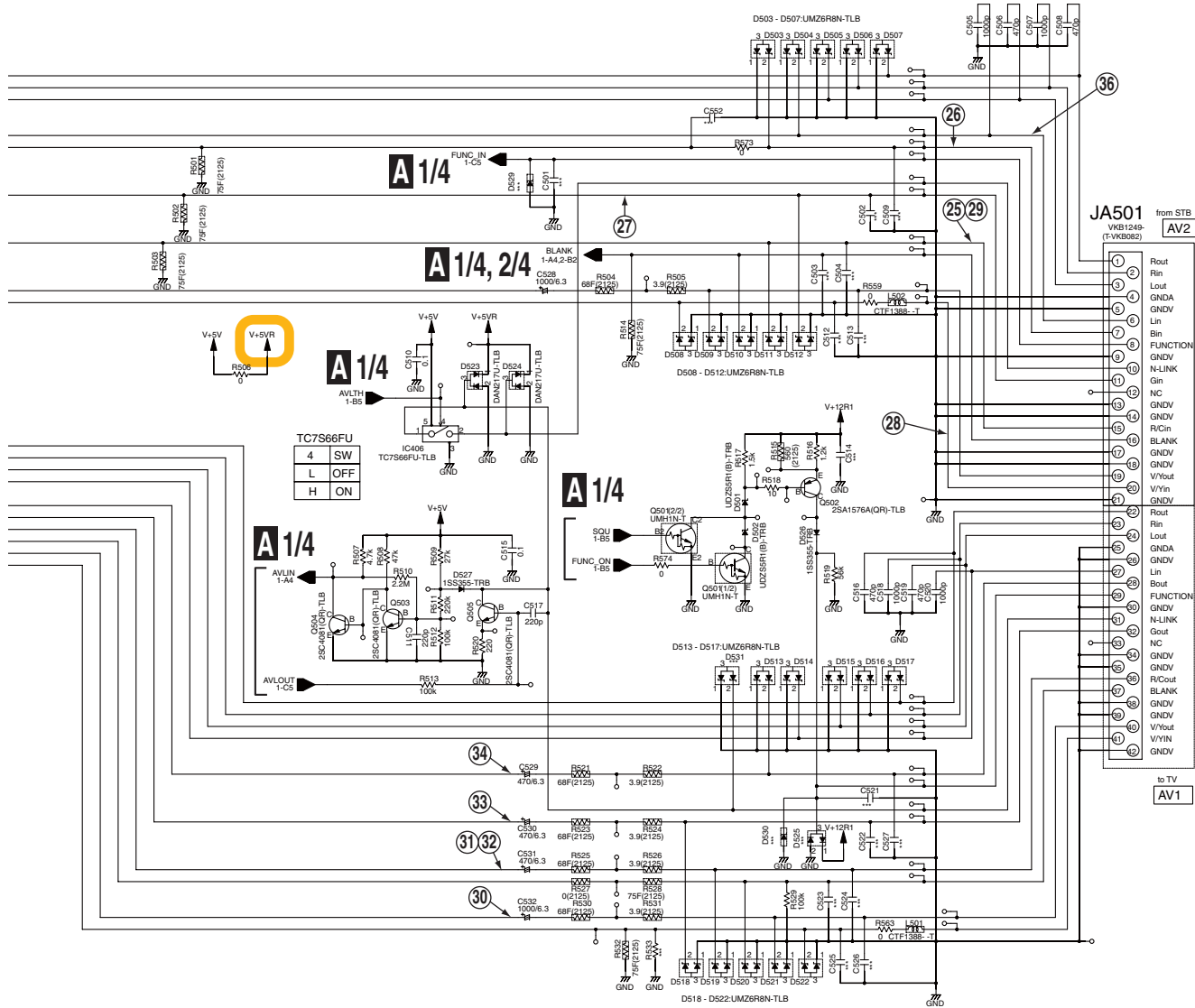

10.4 SERVICE TUSB ASSY (4/4)

A 4/4 SERVICE TUSB ASSY (4/4) (VXX3230)

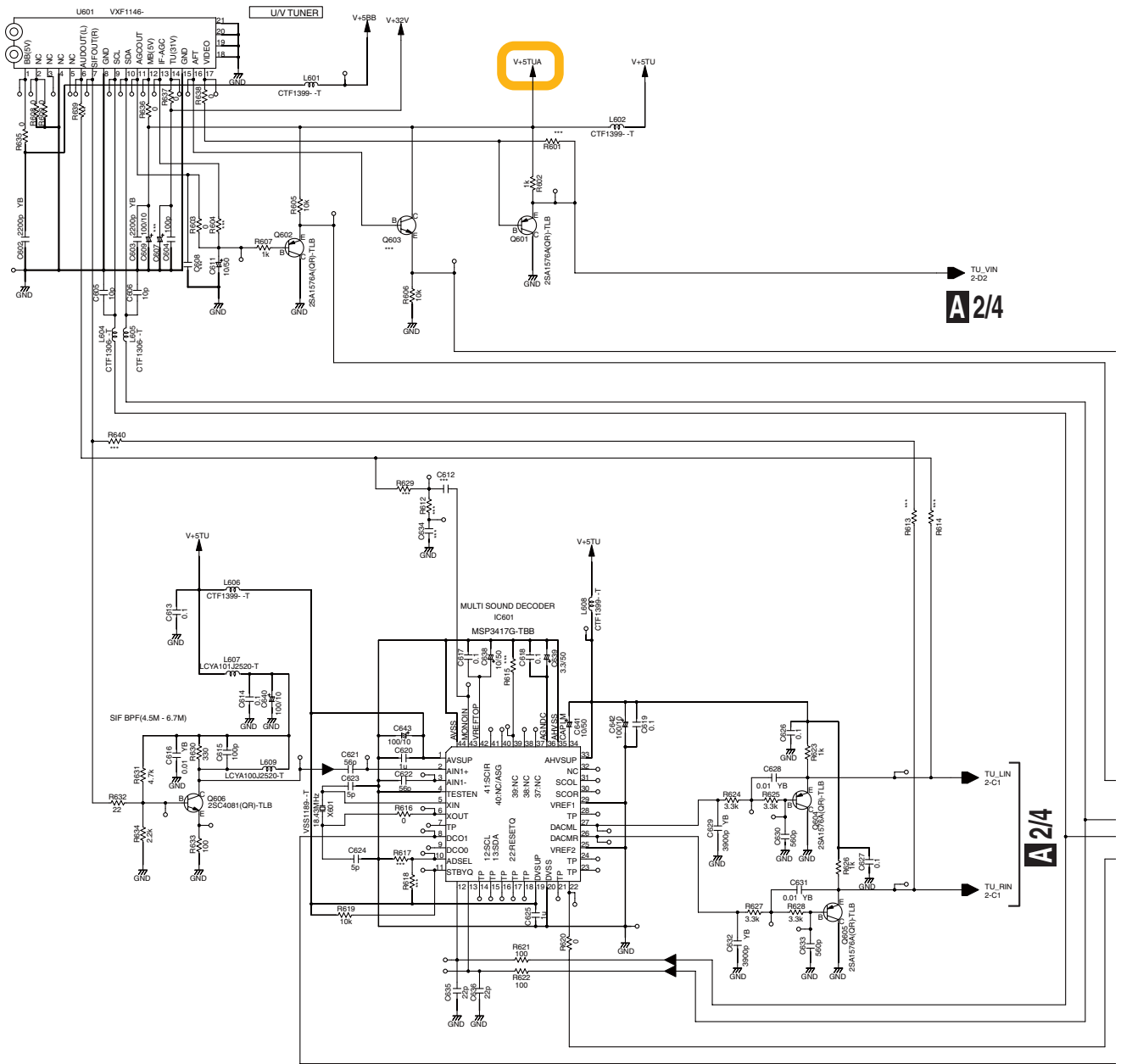

A 2/4

A 2/4

TU_VIN
2-D2

2/4

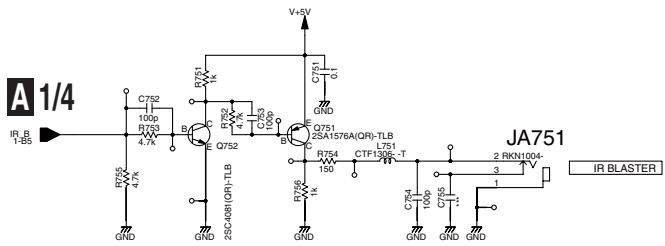
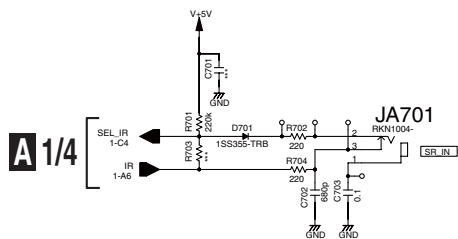
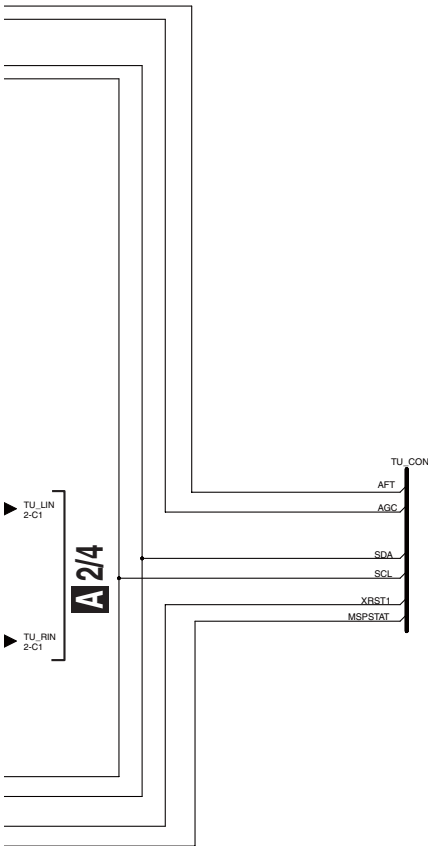

10.5 SERVICE FLKY ASSY

A
B
C
D
E
F

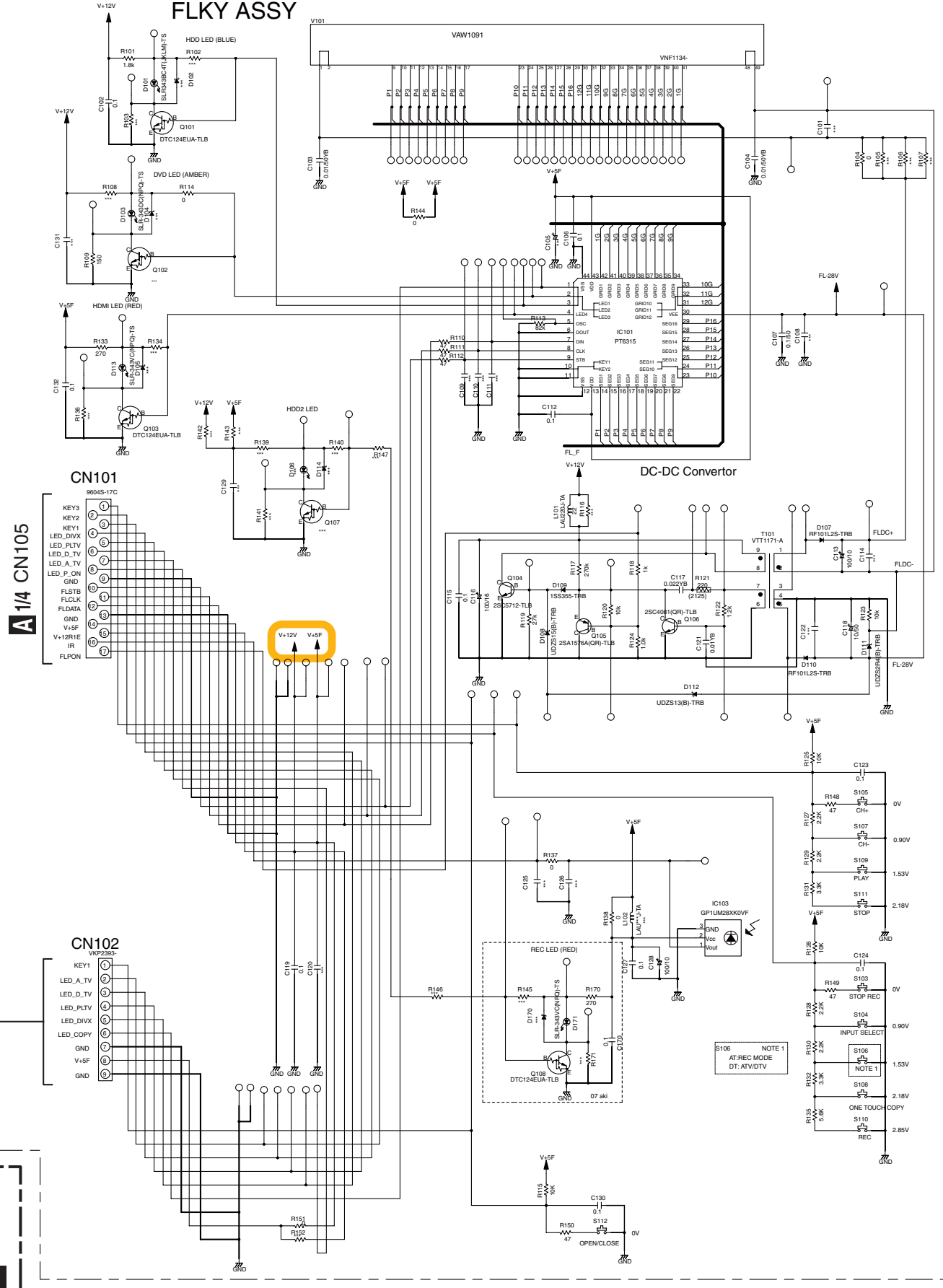

B C

A
B
C
D
E
F

B SERVICE FLKY ASSY
 (VXX3259 : DVR-LX60)
 (VXX3226 : DVR-550H-S, DVR-550H-AV)

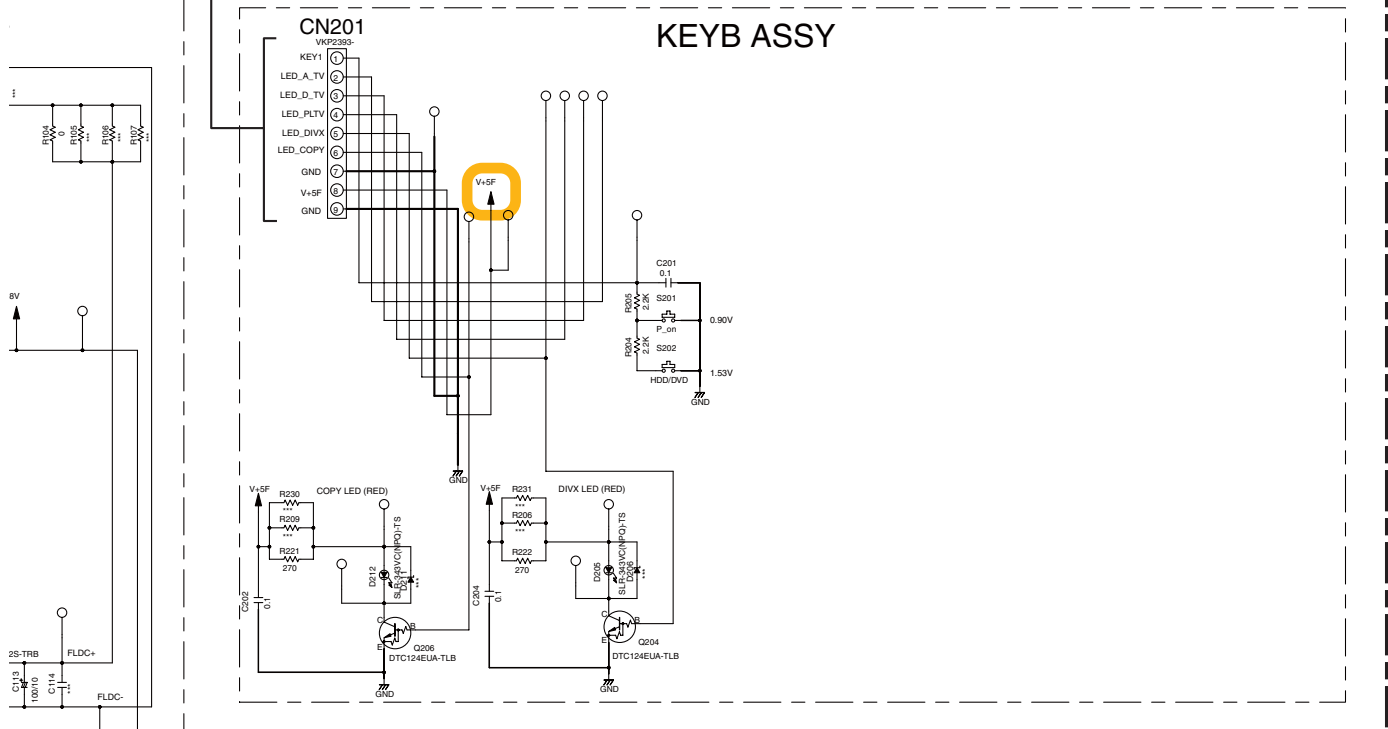

C SERVICE FRJB ASSY
 (VXX3227)

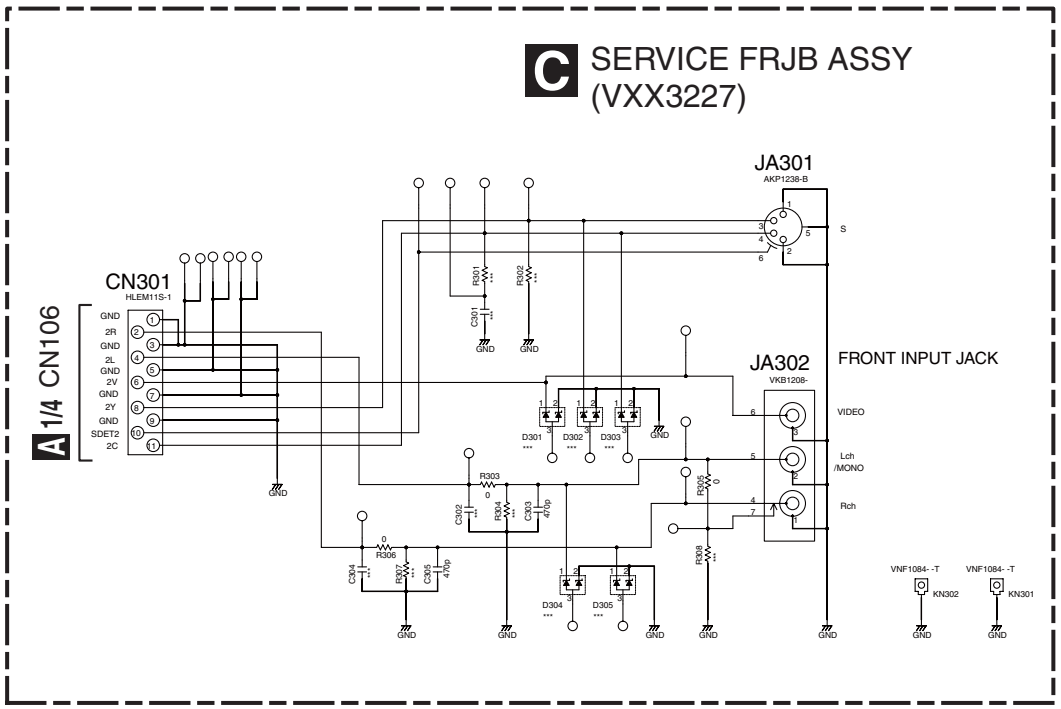
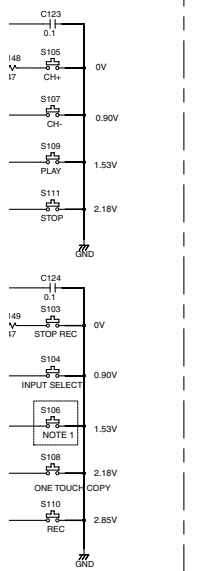

10.6 SERVICE MAIN ASSY (1/5)

A
B
C
D
E
F

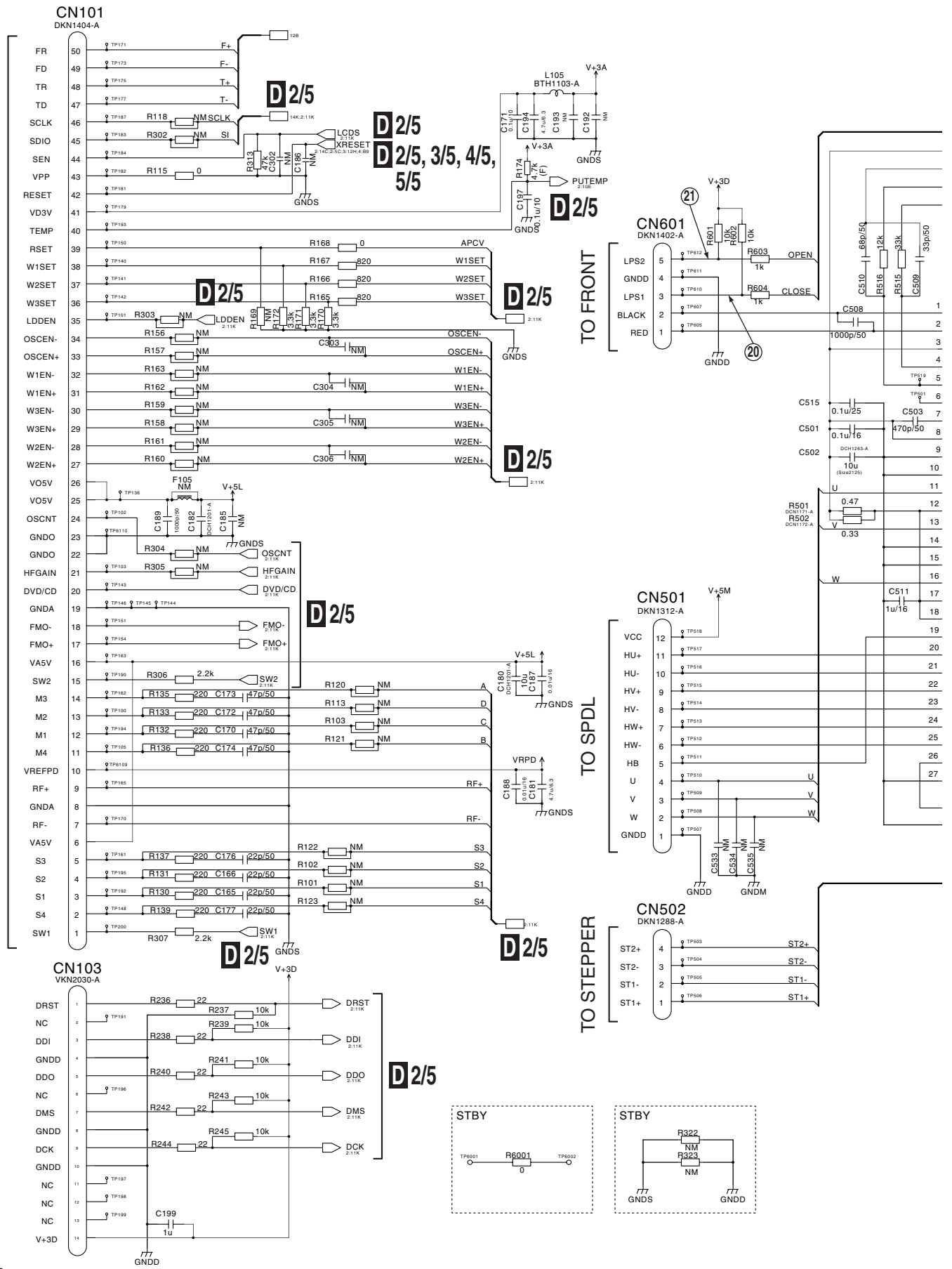

D 1/5 SERVICE MAIN ASSY (1/5)
 (VXX3241 : DVR-LX60)
 (VXX3240 : DVR-550H-S, DVR-550H-AV)

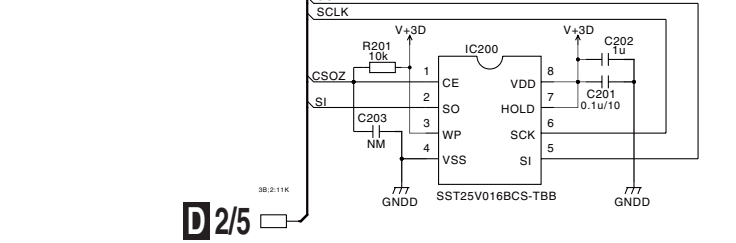
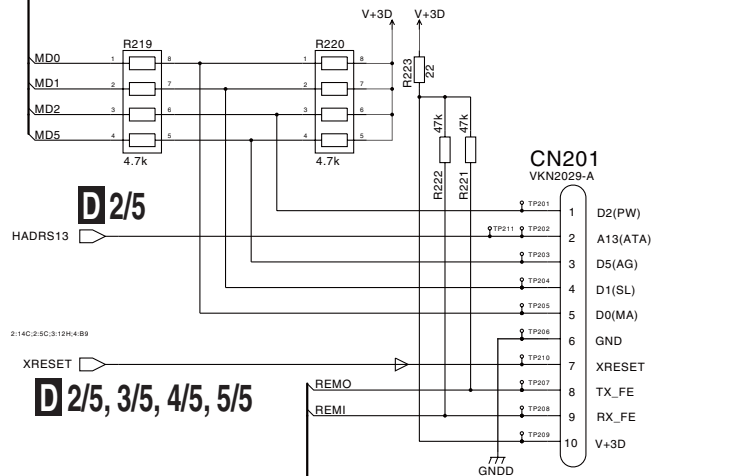
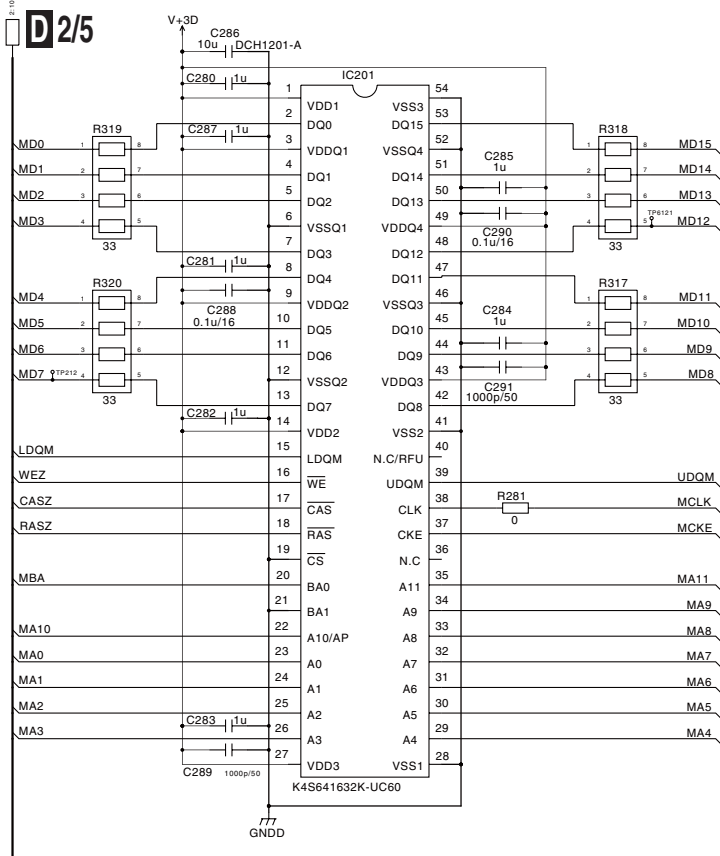
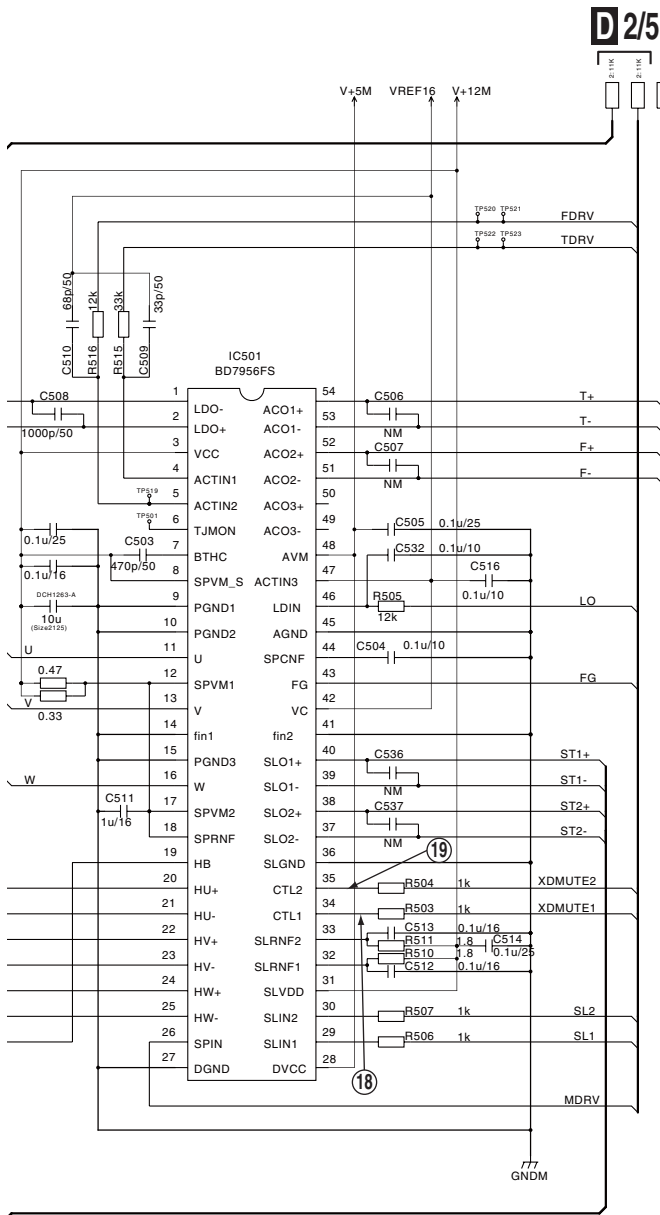

10.7 SERVICE MAIN ASSY (2/5)

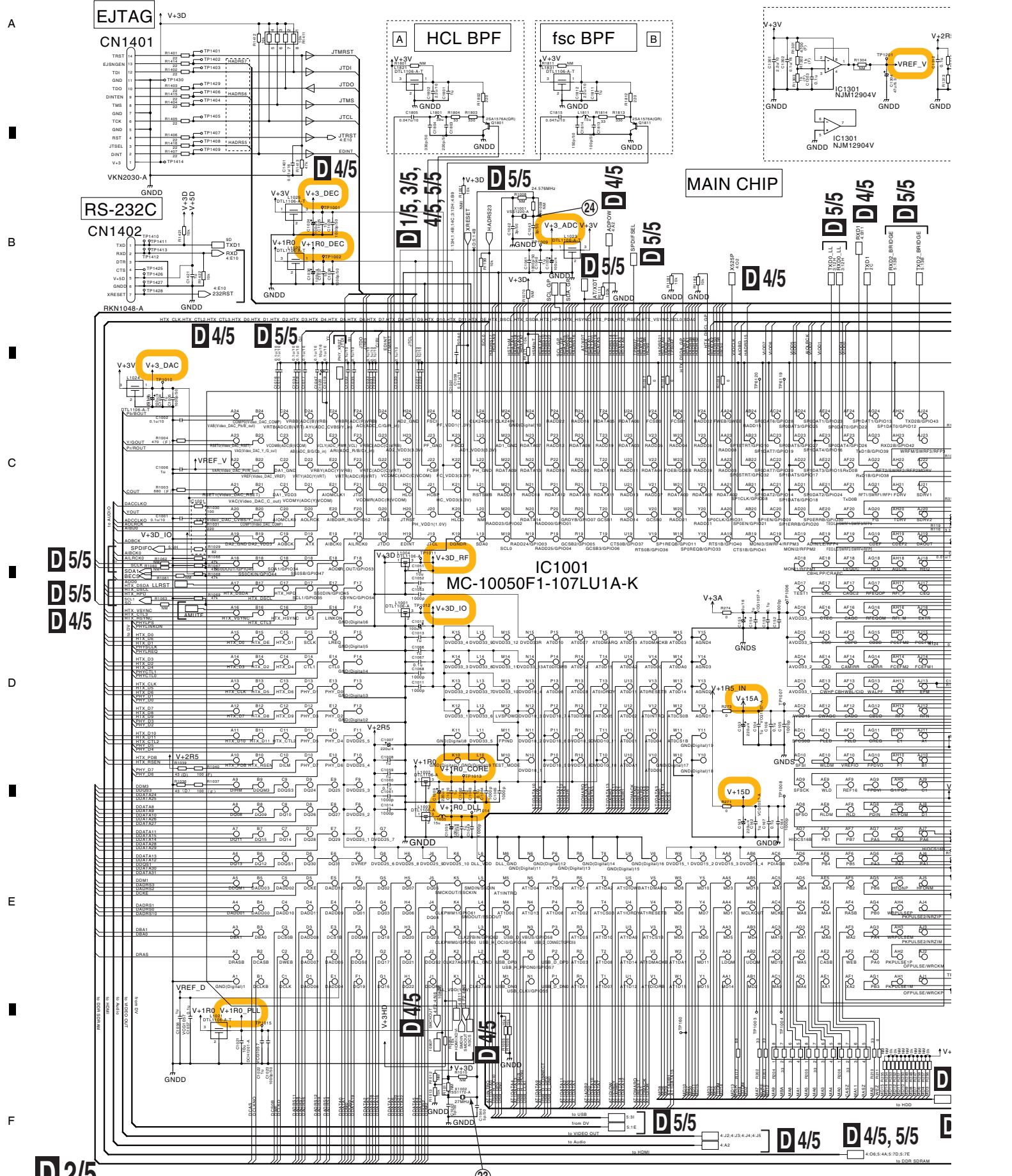

D 2/5 SERVICE MAIN ASSY (2/5)

(VXX3241 : DVR-LX60)
(VXX3240 : DVR-550H-S, DVR-550H-AV)

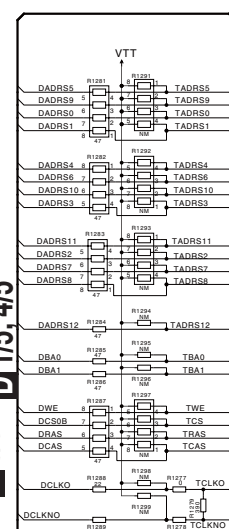
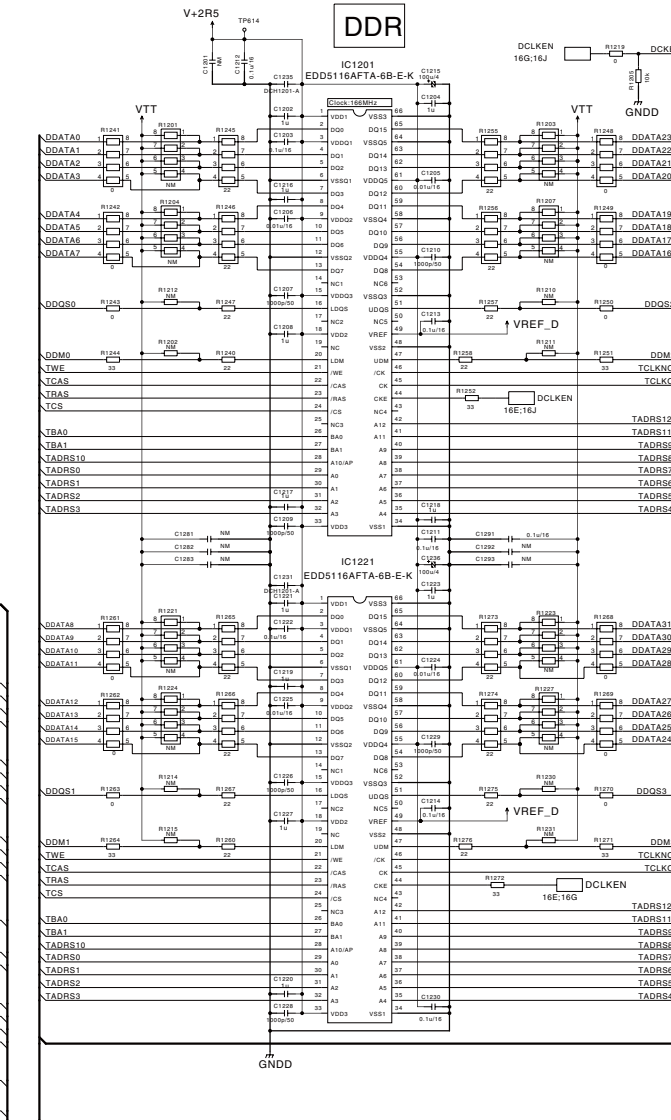
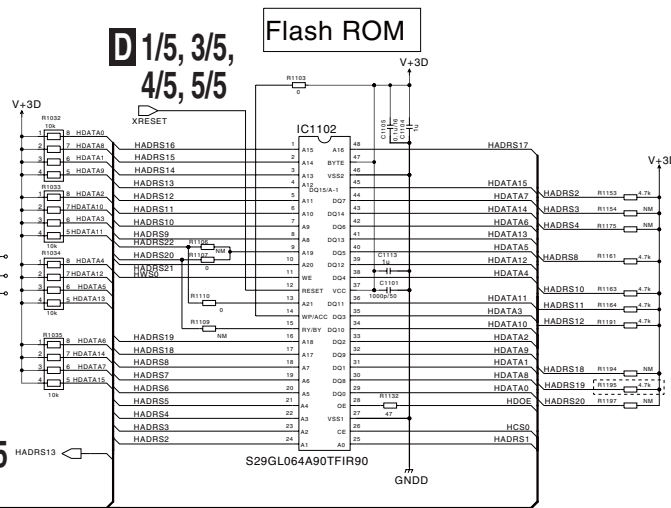
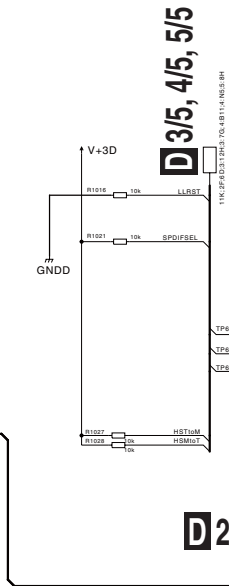
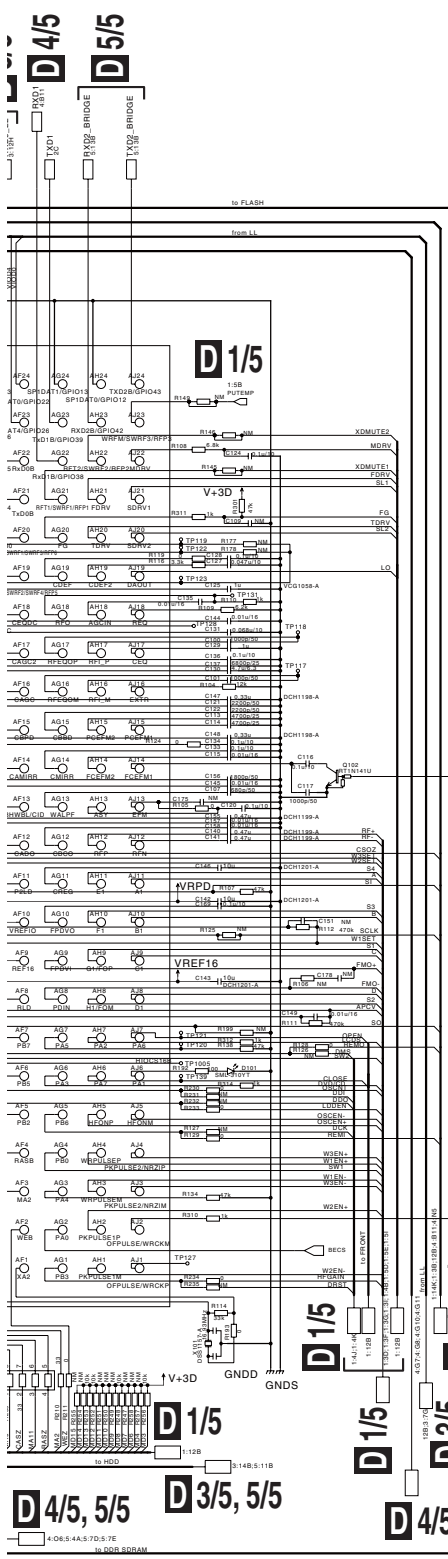
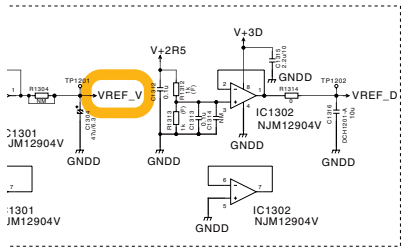

10.8 SERVICE MAIN ASSY (3/5)

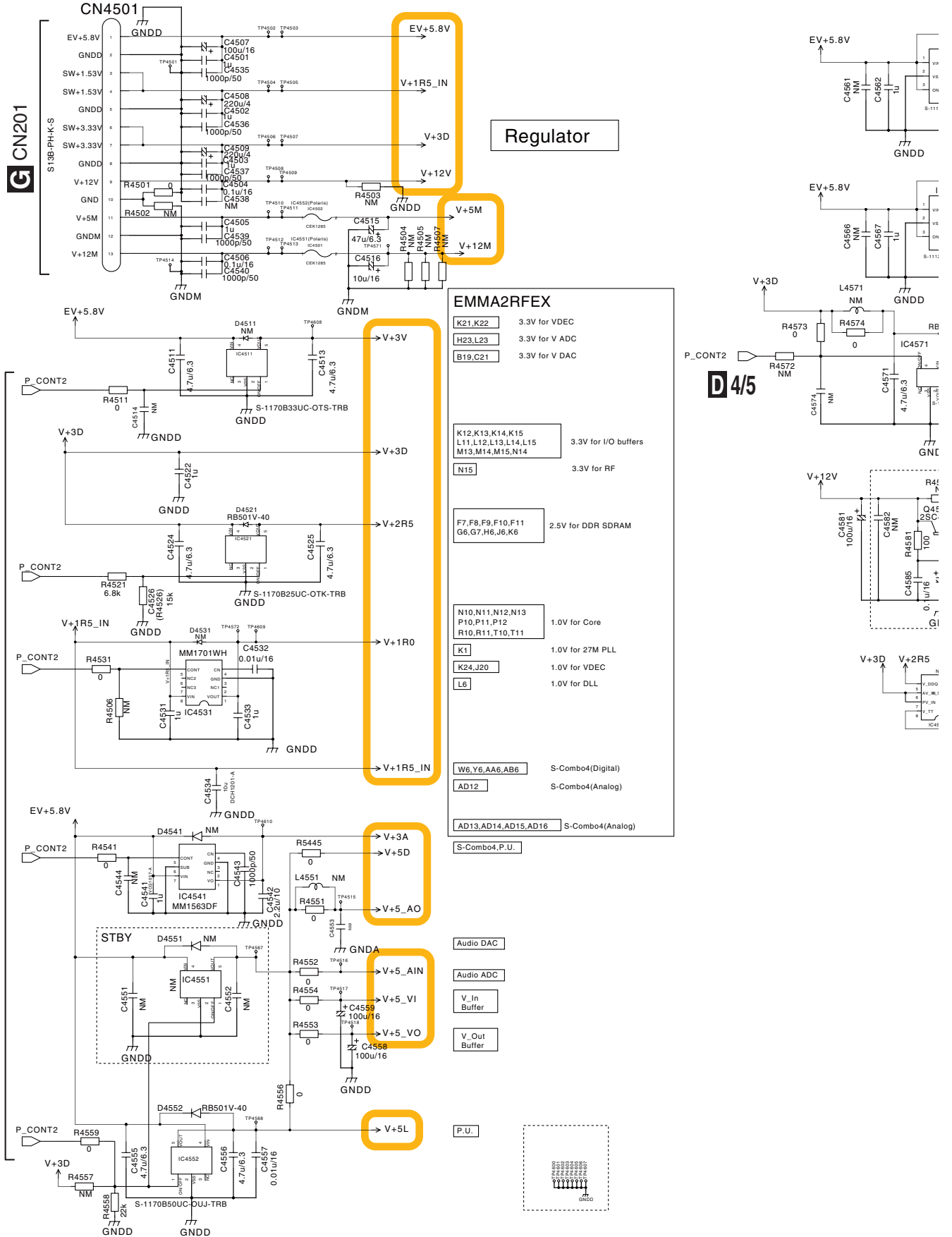

D 3/5 SERVICE MAIN ASSY (3/5)

(VXX3241 : DVR-LX60)
(VXX3240 : DVR-550H-S, DVR-550H-AV)

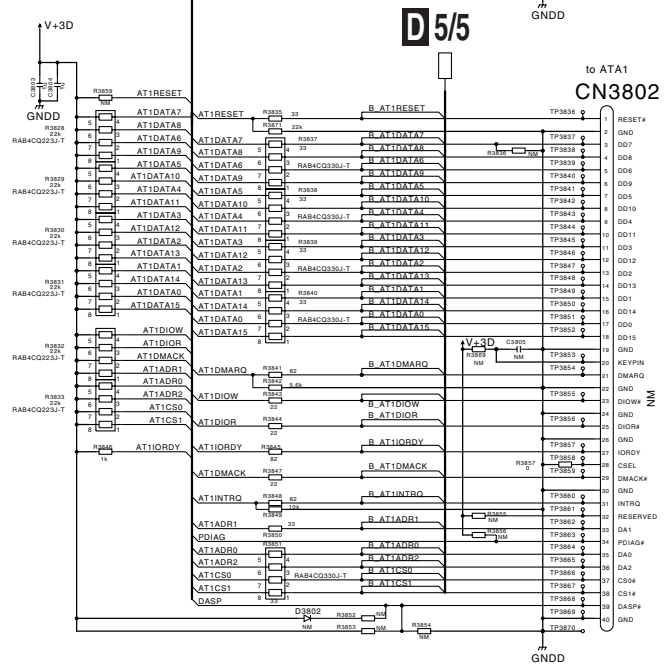
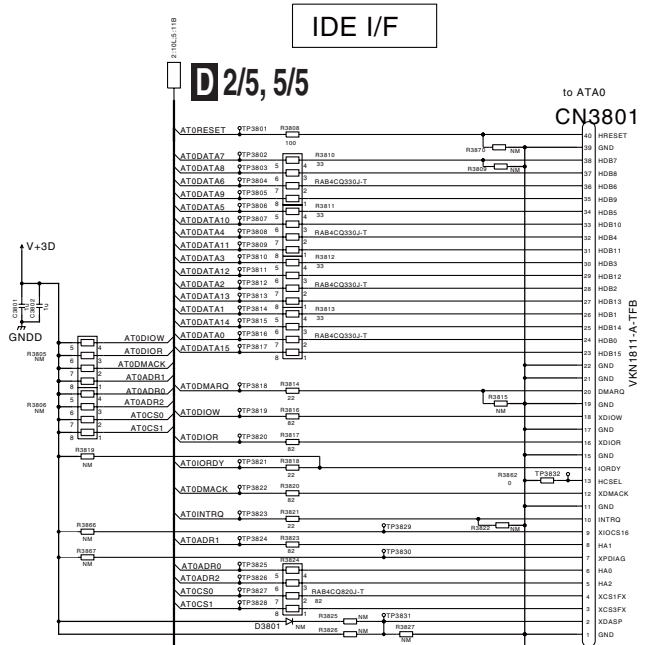
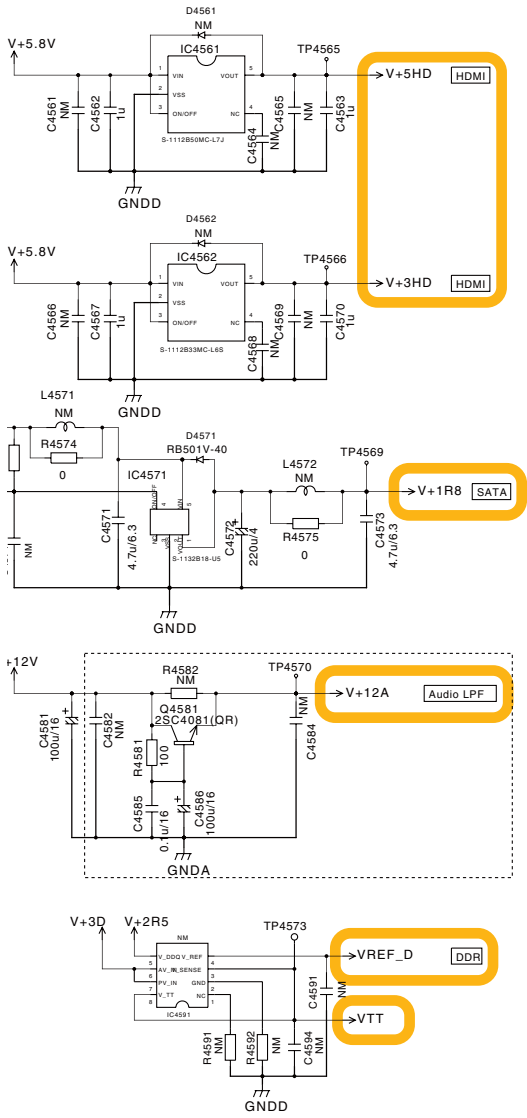

10.9 SERVICE MAIN ASSY (4/5)

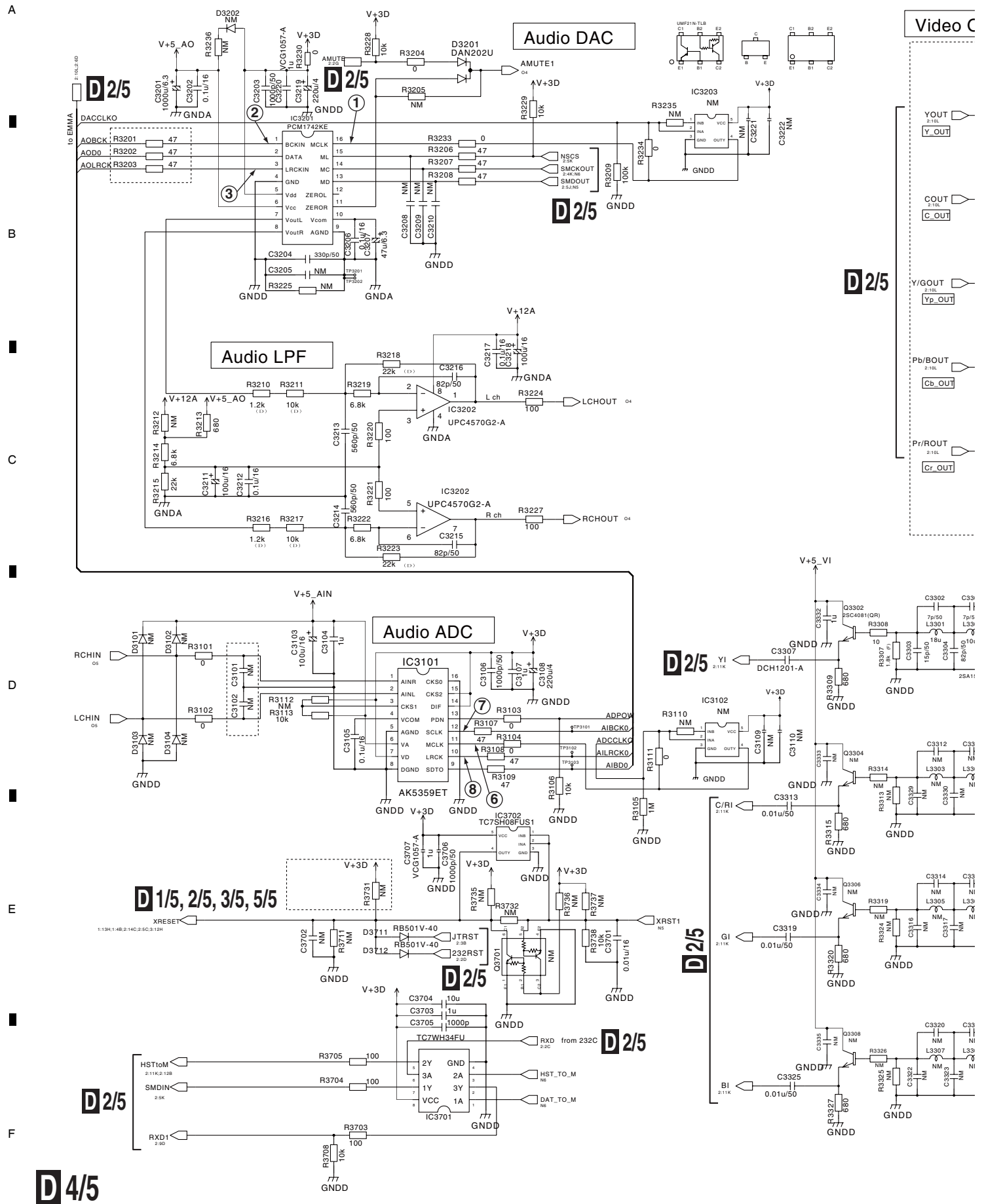

D 4/5 SERVICE MAIN ASSY (4/5)

(VXX3241 : DVR-LX60)
(VXX3240 : DVR-550H-S, DVR-550H-AV)

A
B
C
D
E
F

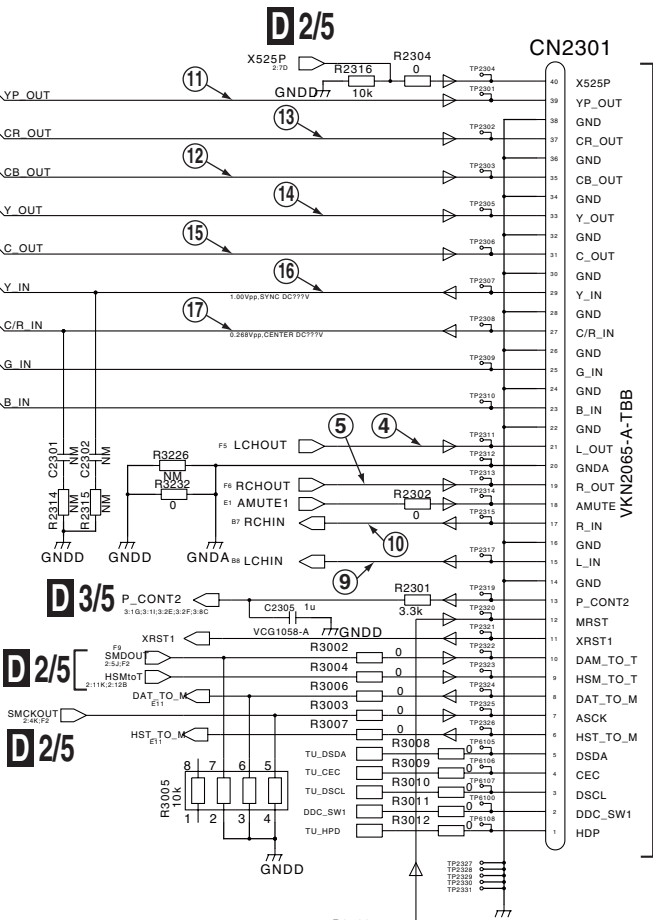
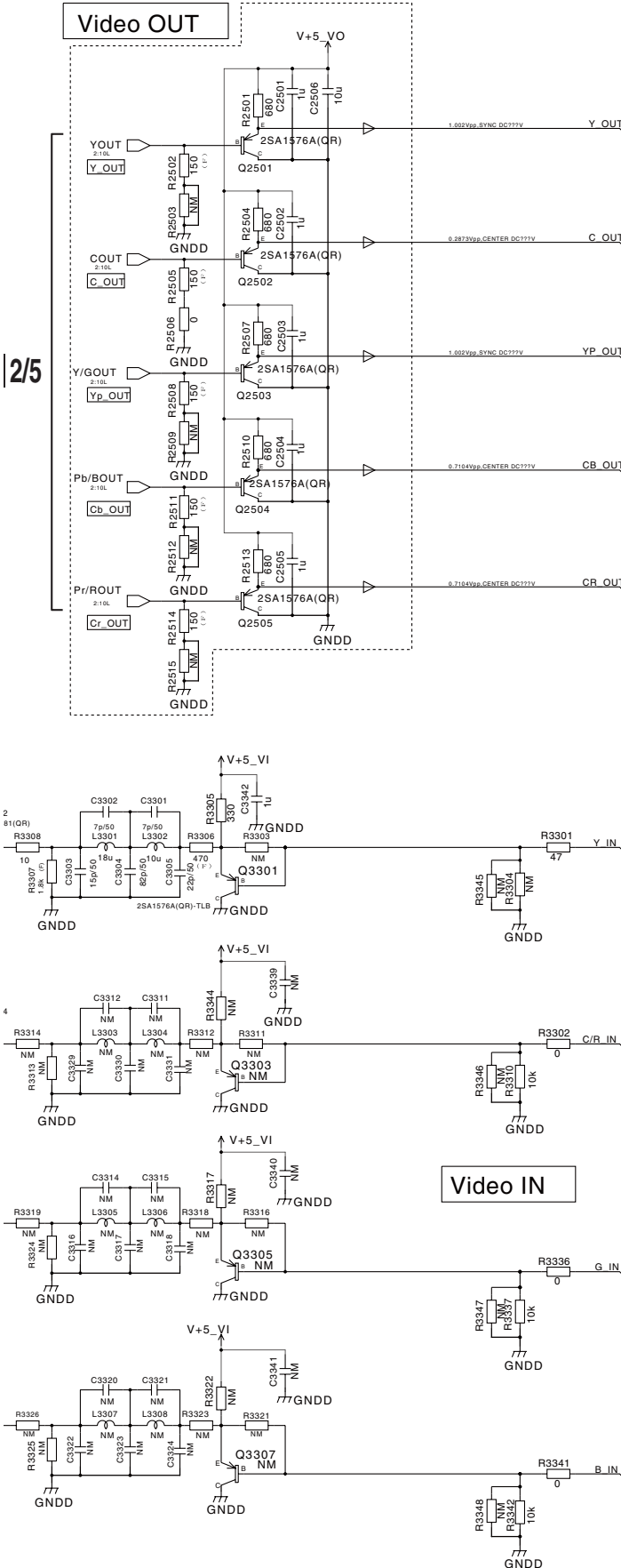

A 1/4 CN101

10.10 SERVICE MAIN ASSY (5/5)

D 5/5 SERVICE MAIN ASSY (5/5) (VXX3241 : DVR-LX60) (VXX3240 : DVR-550H-S, DVR-550H-AV)

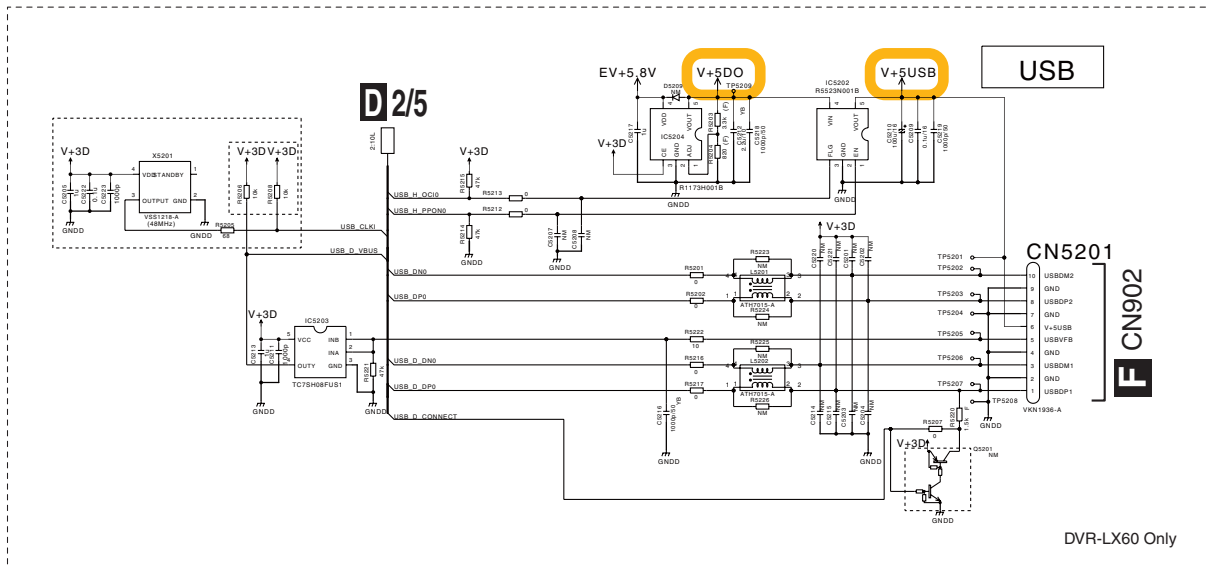
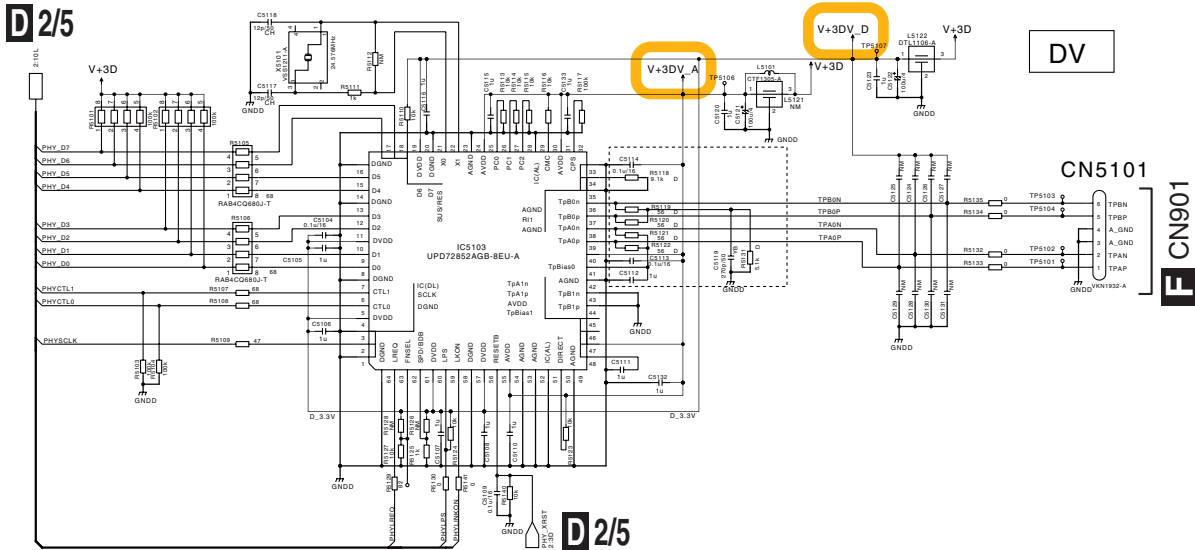
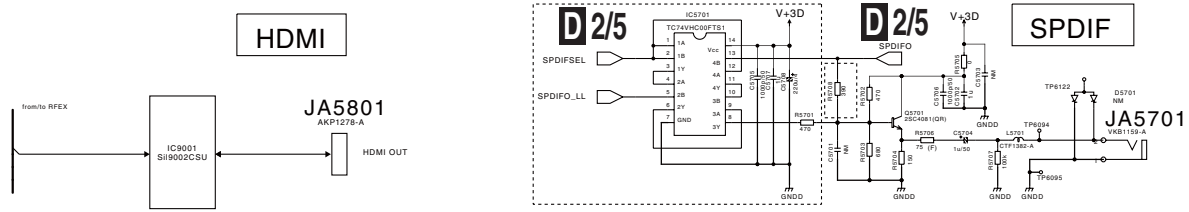

701

1
2
3
4
5
6
7
8
9
10
11
12
13
14
15
16
17
18
19
20
21
22
23
24
25
26
27
28
29
30
31
32
33
34
35
36
37
38
39
40
41
42
43
44
45
46
47
48
49
50
51
52
53
54
55
56
57
58
59
60
61
62
63
64
65
66
67
68
69
70
71
72
73
74
75
76
77
78
79
80
81
82
83
84
85
86
87
88
89
90
91
92
93
94
95
96
97
98
99
100

11y

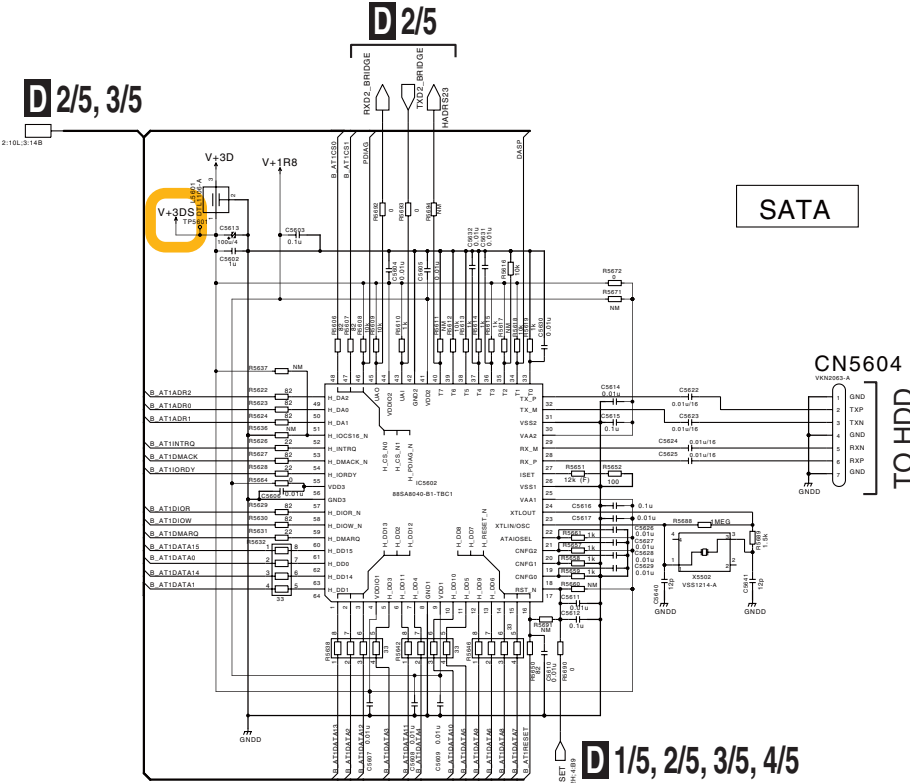
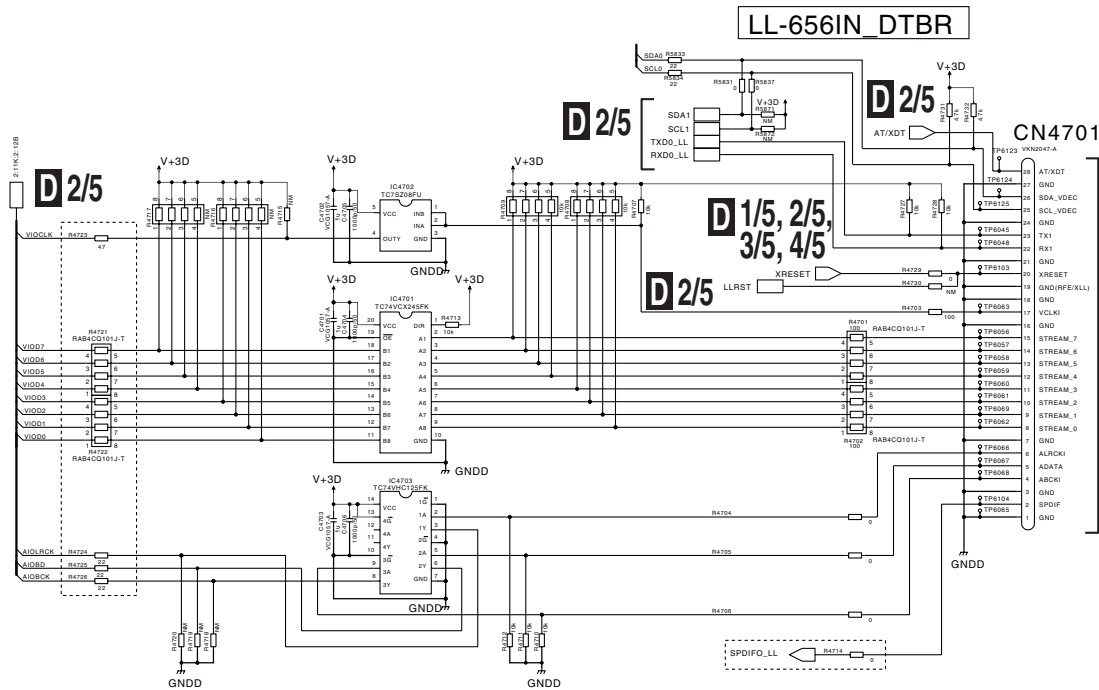

10.11 VDEC ASSY

VDEC ASSY (VWV2304)

A
B
C
D
E
F

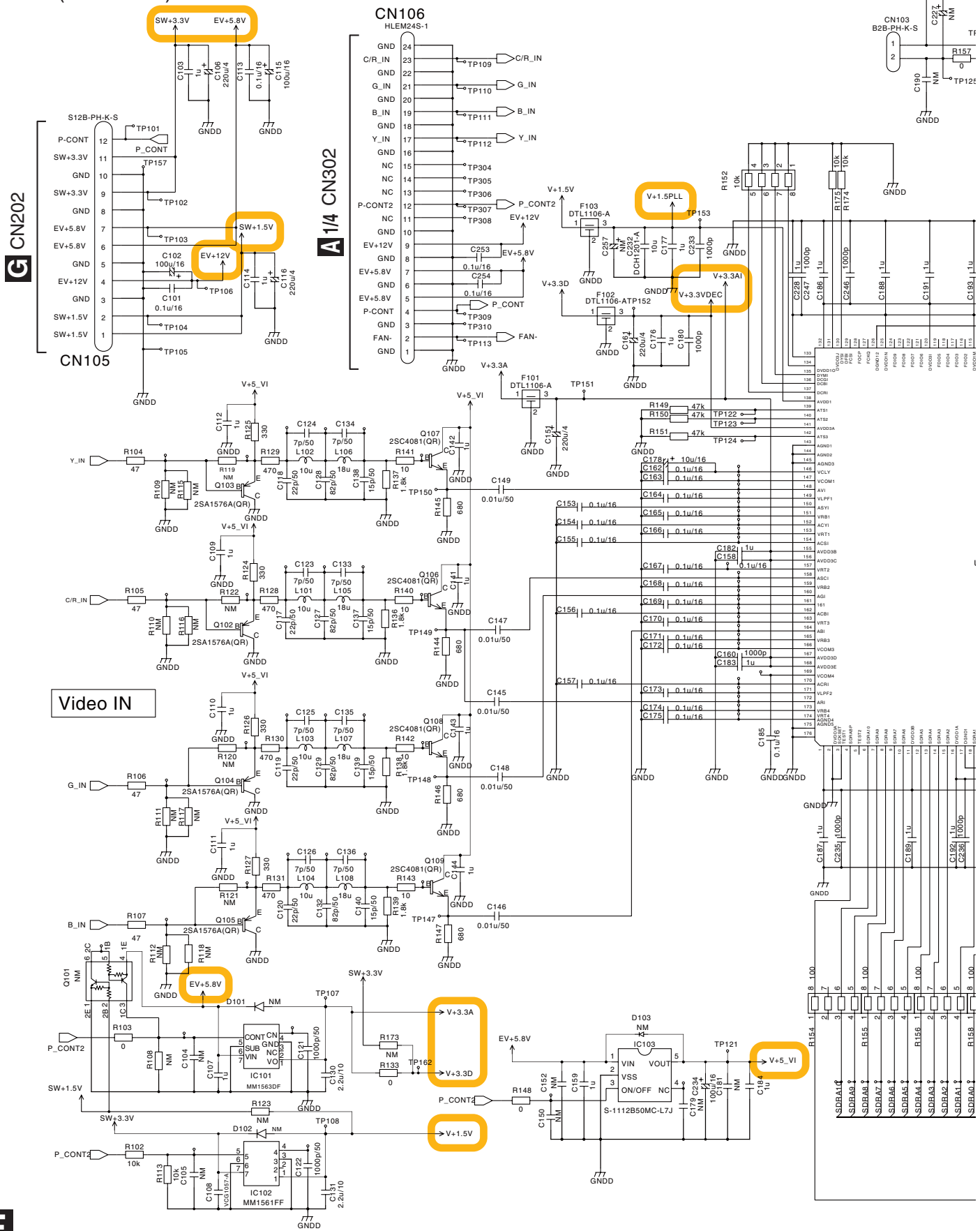

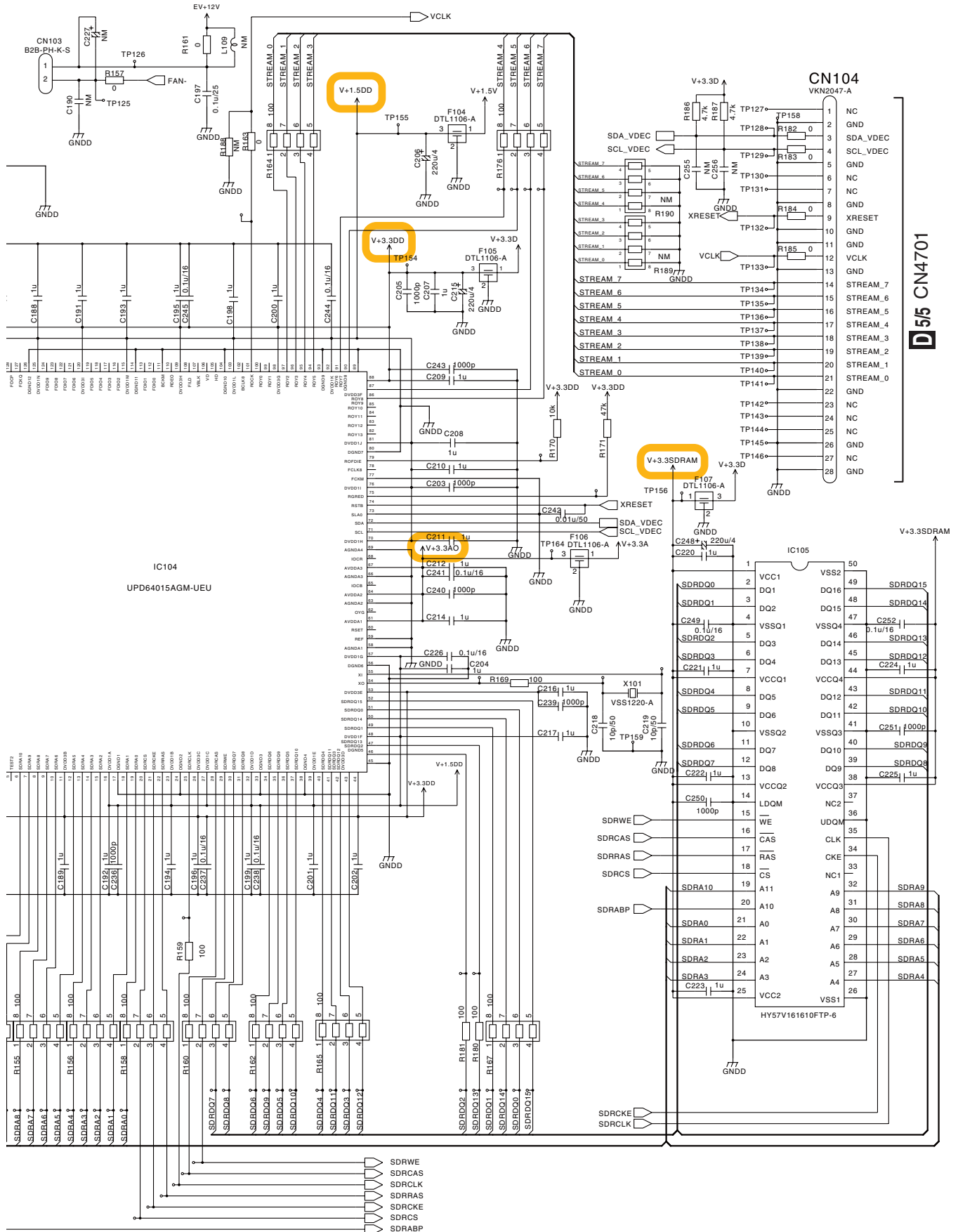

A
B
C
D
E
F



10.12 SERVICE DVUB ASSY

F SERVICE DVUB ASSY
 (VXX3231 : DVR-LX60)
 (VXX3232 : DVR-550H-S, DVR-550H-AV)

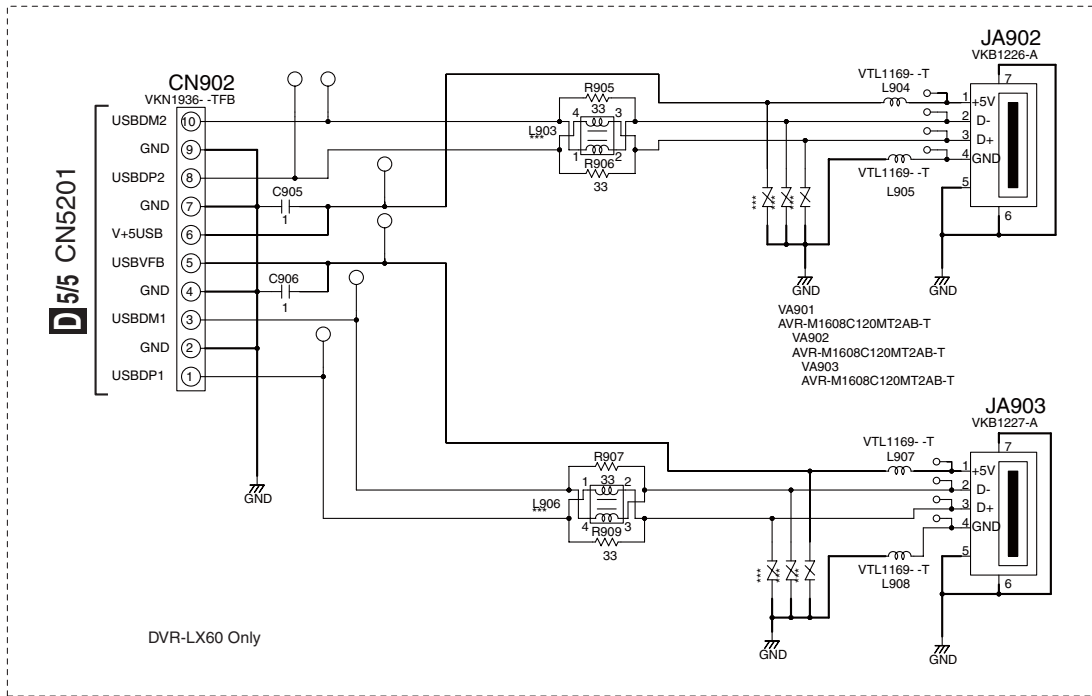
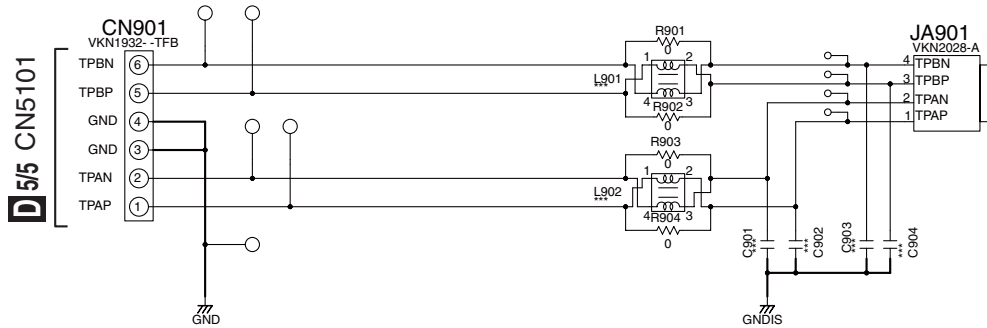

VA904
 AVR-M1608C120MT2AB-T
 VA905
 AVR-M1608C120MT2AB-T
 VA906
 AVR-M1608C120MT2AB-T

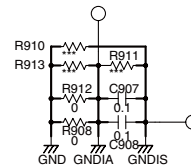

■

5

■

6

■

7

■

8

■

A

■

B

■

C

■

D

■

E

■

F

■

5

■

6

DVR-LX60

■

7

■

8

■

10.13 POWER SUPPLY ASSY

G POWER SUPPLY ASSY (VWR1406)

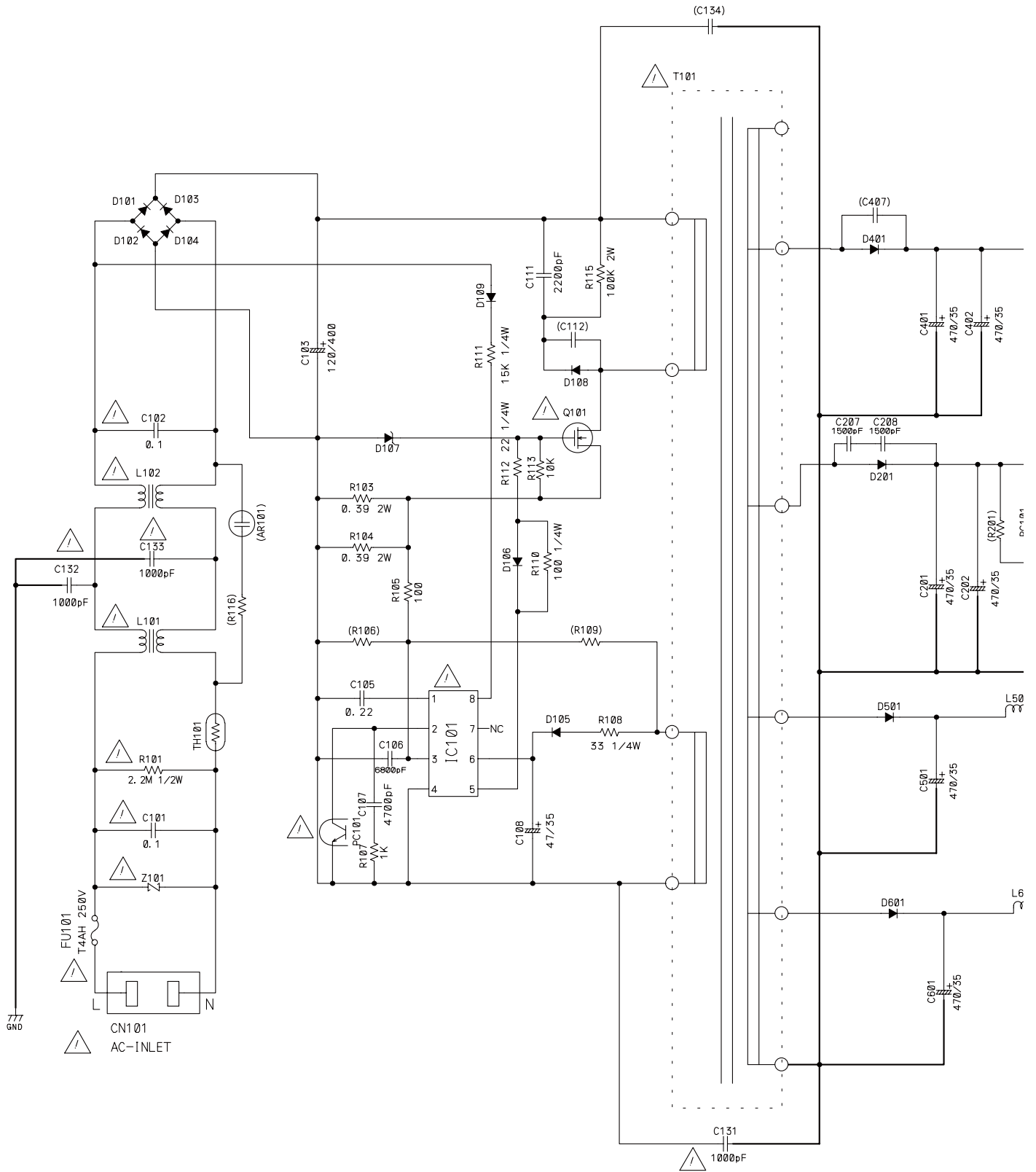

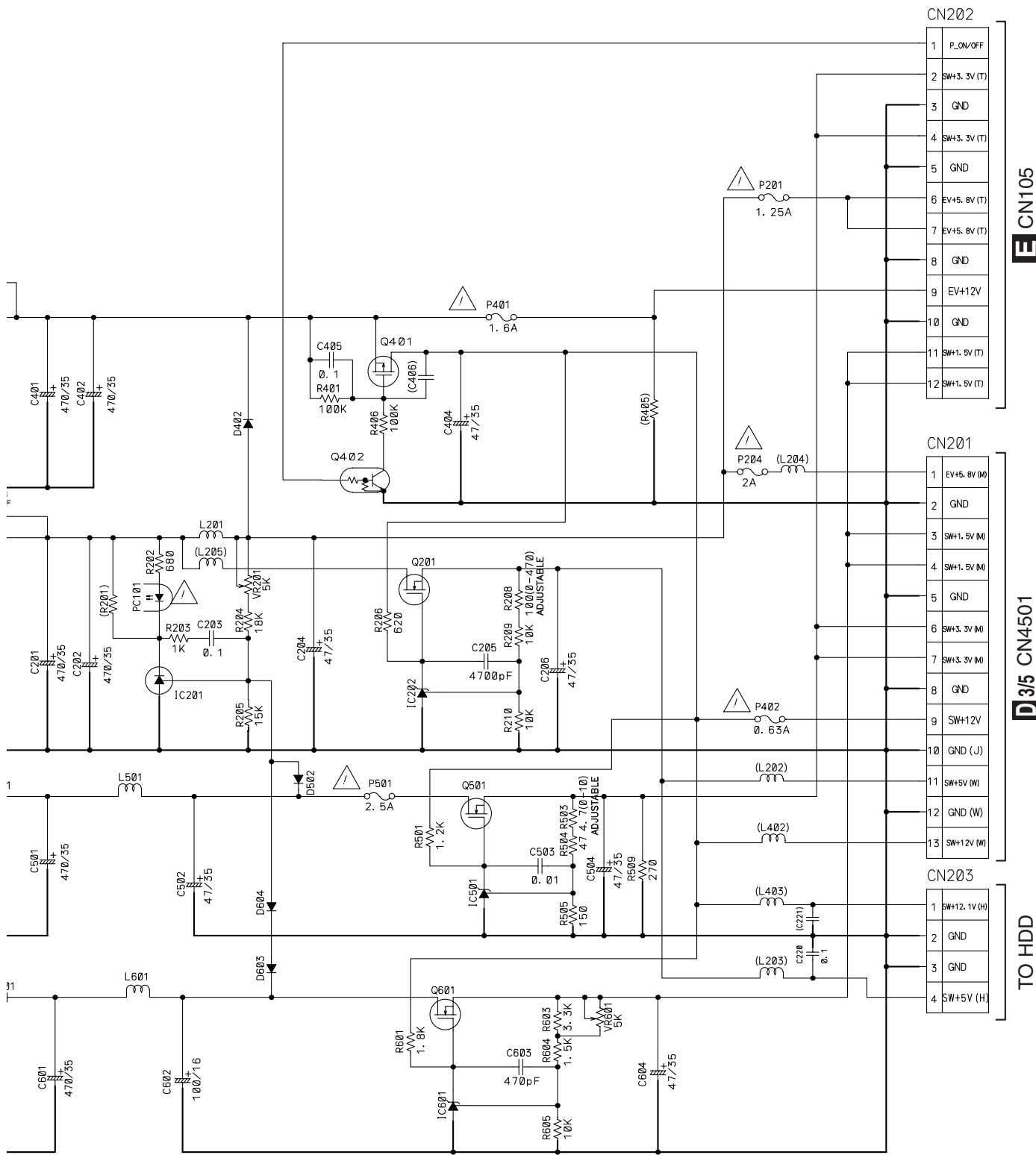

E CN105

D 3/5 CN4501

TO HDD

Unit	Resistor	Ω/W (under 1/4W for no direction W)
	Capacitor	$\mu F/V$ (under 50V for no direction V)

10.14 WAVE FORMS

Note : The encircled numbers denote measuring point in the schematic diagram.

A SERVICE TUSB ASSY

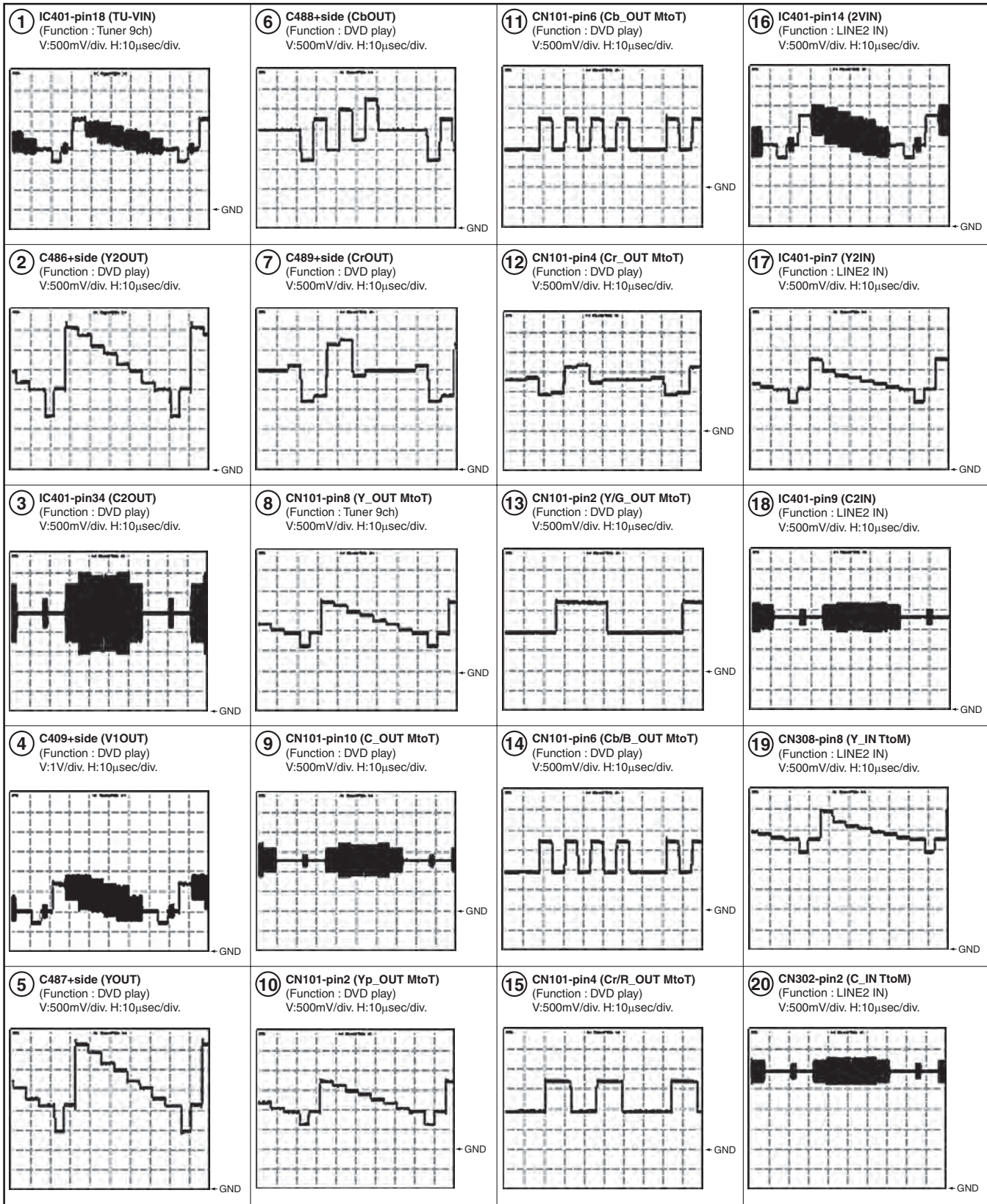

A SERVICE TUSB ASSY

Measurement Condition :

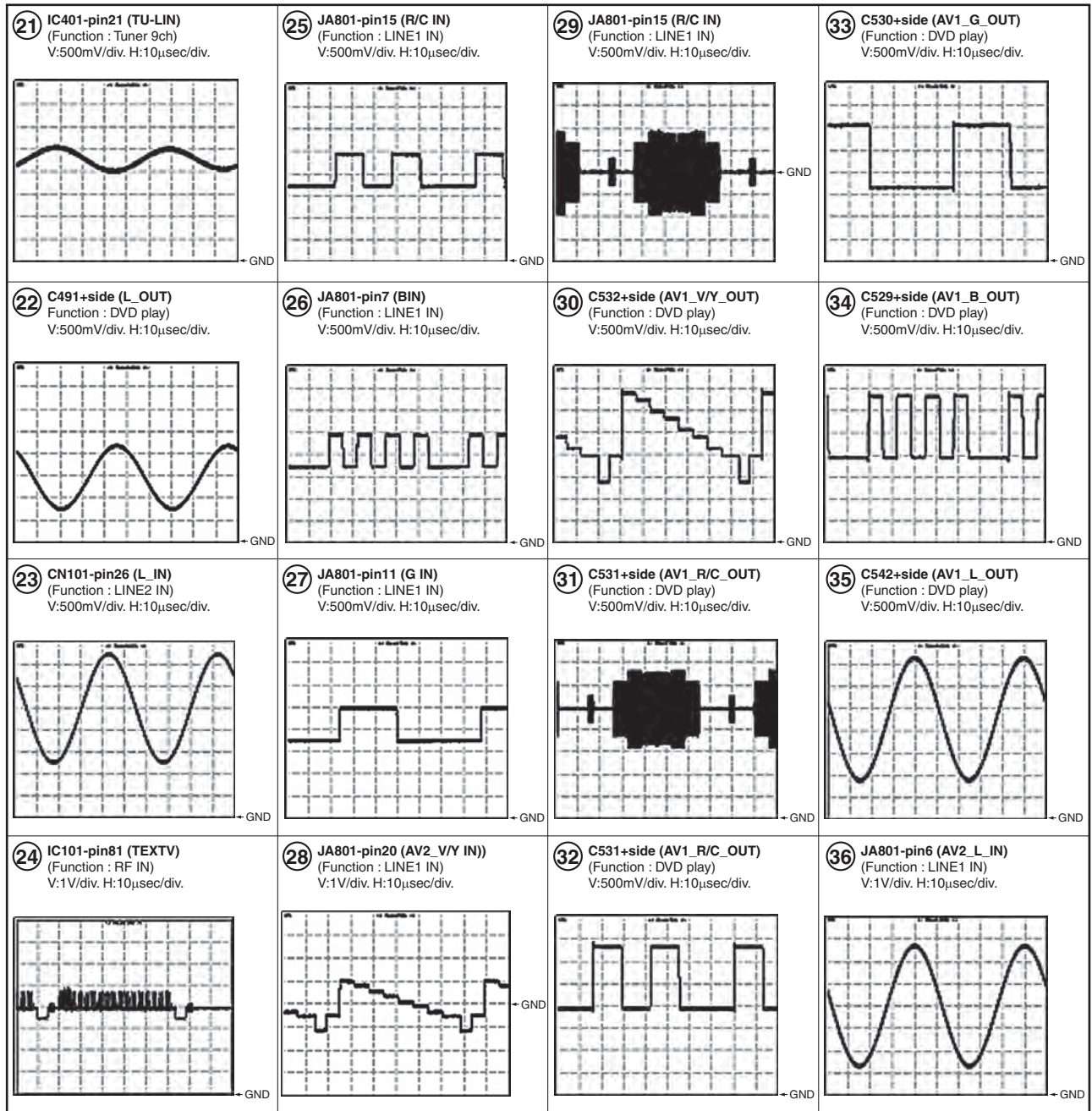

D SERVICE MAIN ASSY

Measurement Condition :

A No.1 - 8 : EBU Color Bar (100 / 0 / 75 / 0)

B

C

D

E

F

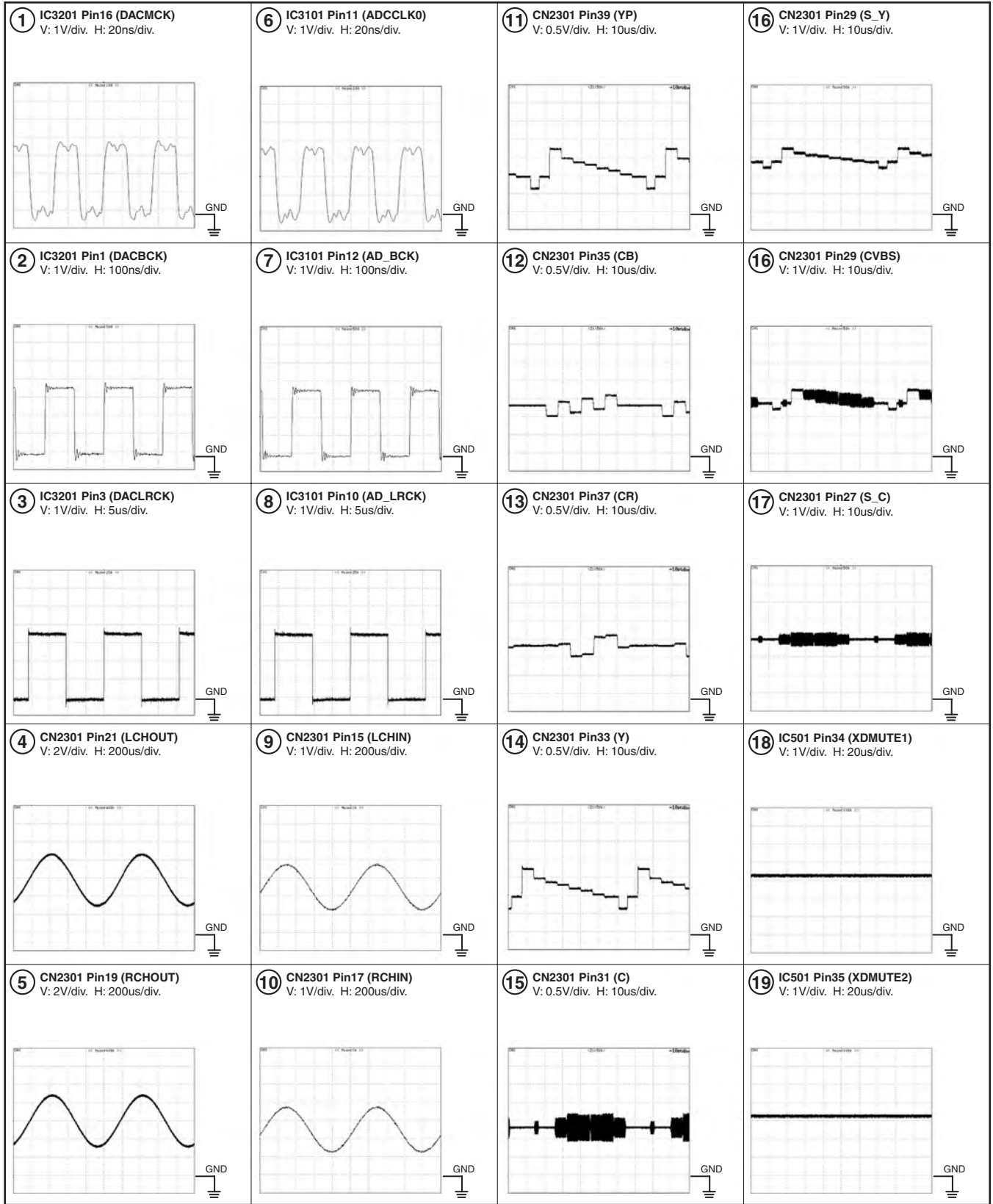

D SERVICE MAIN ASSY

A
B
C
D
E
F

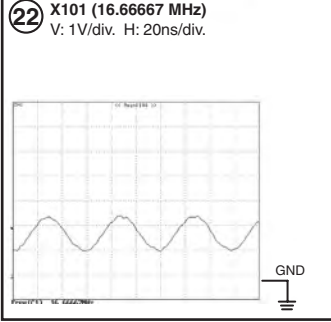
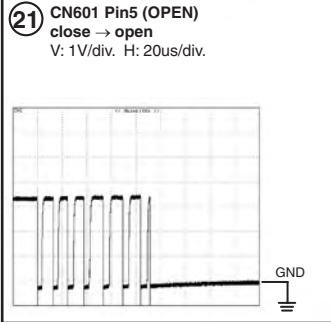
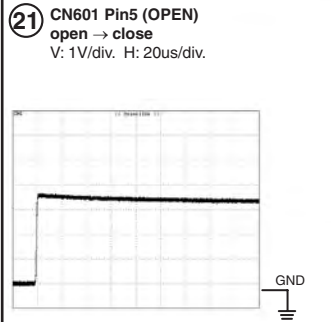
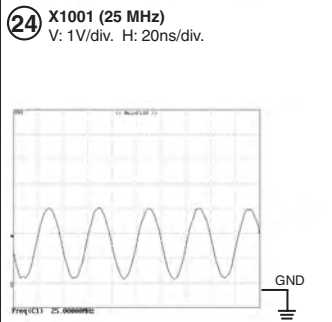
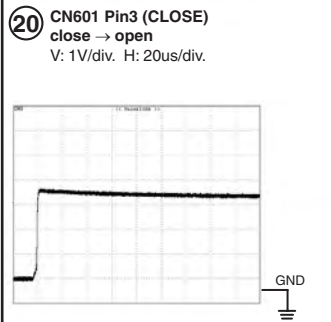
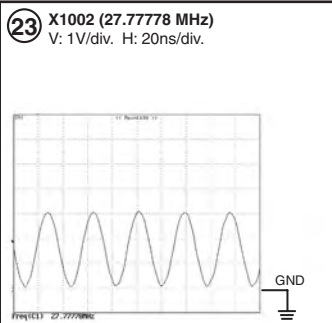
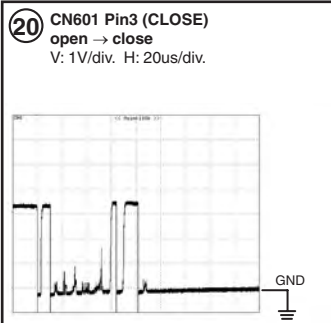

1

2

3

4

A

B

C

D







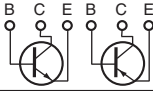

E

F

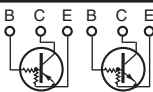
11. PCB CONNECTION DIAGRAM

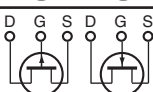
NOTE FOR PCB DIAGRAMS :

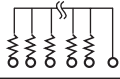
1. Part numbers in PCB diagrams match those in the schematic diagrams.
2. A comparison between the main parts of PCB and schematic diagrams is shown below.

Symbol In PCB Diagrams	Symbol In Schematic Diagrams	Part Name
		Transistor
		Transistor with resistor
		Field effect transistor
		Resistor array
		3-terminal regulator

3. The parts mounted on this PCB include all necessary parts for several destinations.
For further information for respective destinations, be sure to check with the schematic diagram.
4. View point of PCB diagrams.

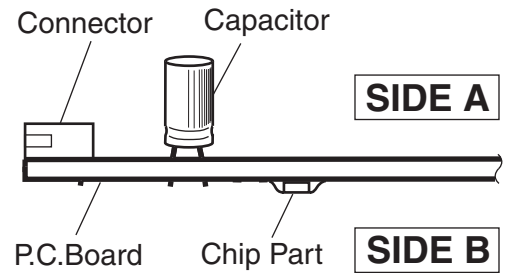

11.1 SERVICE TUSB ASSY

SIDE A

A SERVICE TUSB ASSY (VXX3230)

A
B
C
D
E
F

220
210
200
190
180
170
160
150
140
130
120
110
100
90
80
70
60
50
40
30
20
10
0

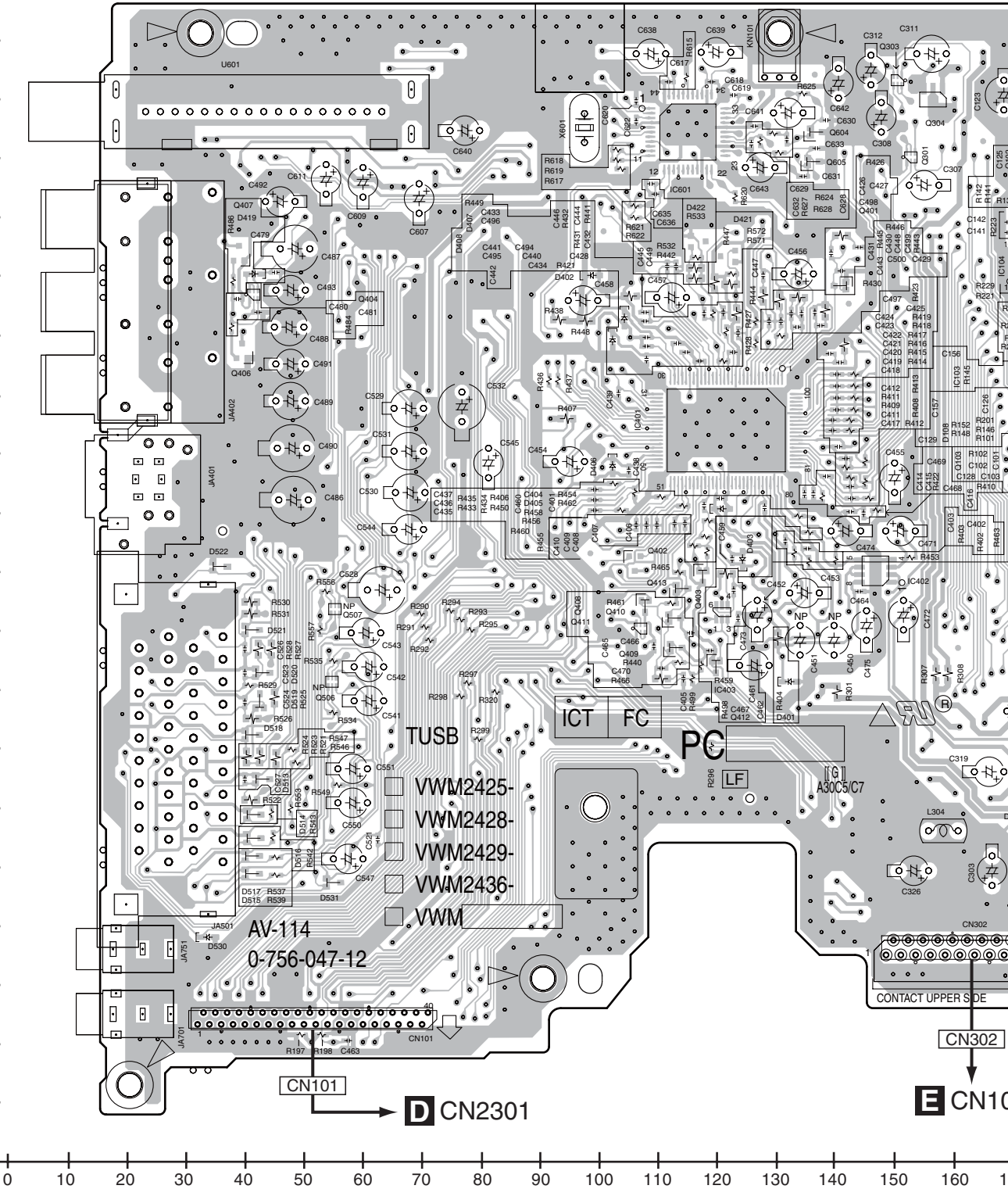

- VWM2425
- VWM2428
- VWM2429
- VWM2436
- VWM

AV-114
0-756-047-12

D CN2301

E CN1C

CONTACT UPPER SIDE

CN302

Y ↑

X →

A

A
B
C
D
E
F

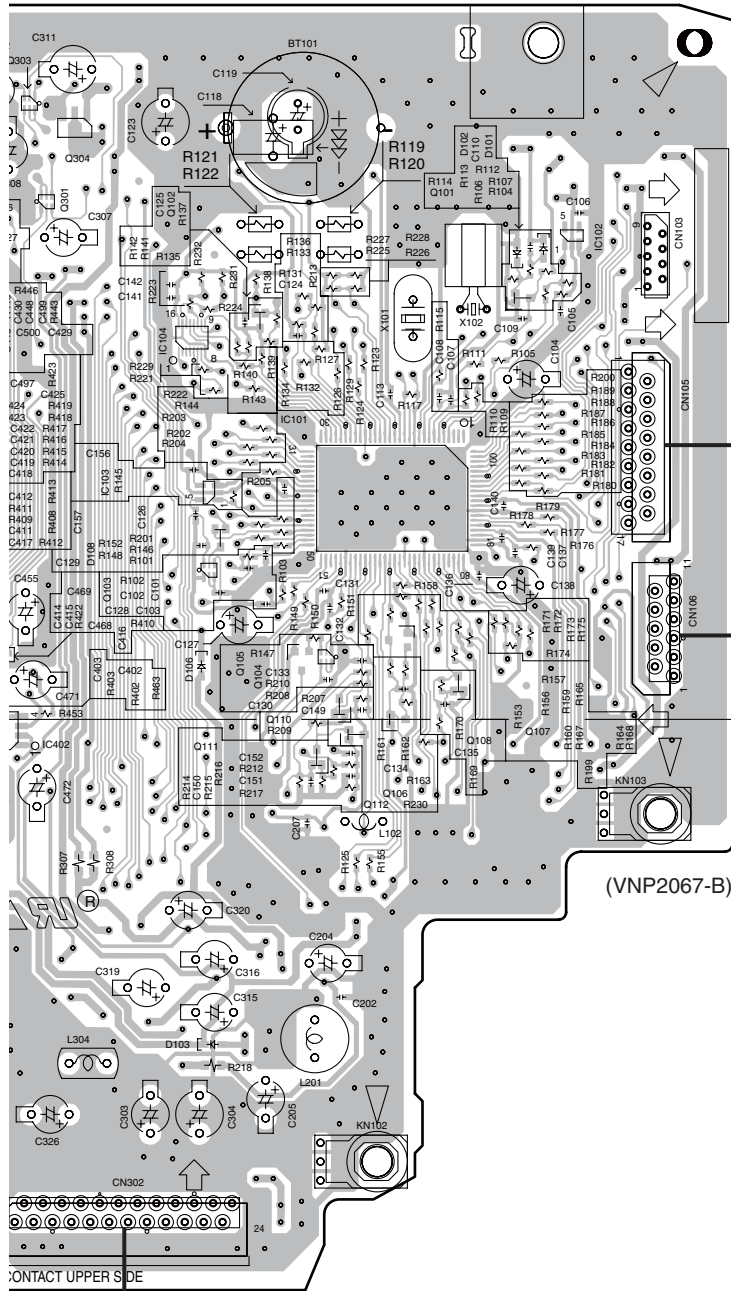

(VNP2067-B)

B CN101

C CN301

E CN106

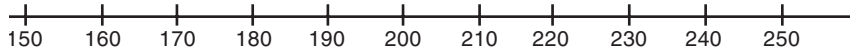

SIDE B

A SERVICE TUSB ASSY (VXX3230)

A

B

C

D

E

F

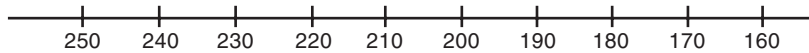
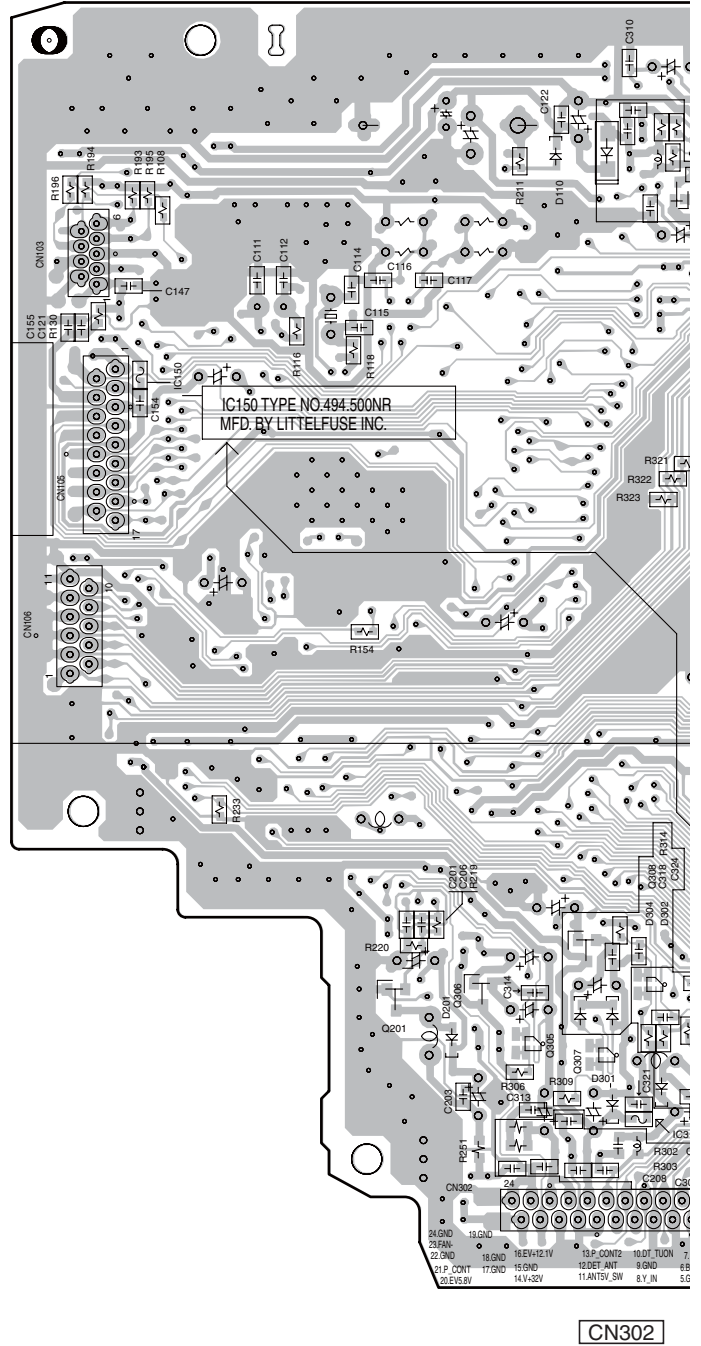

A

SIDE B

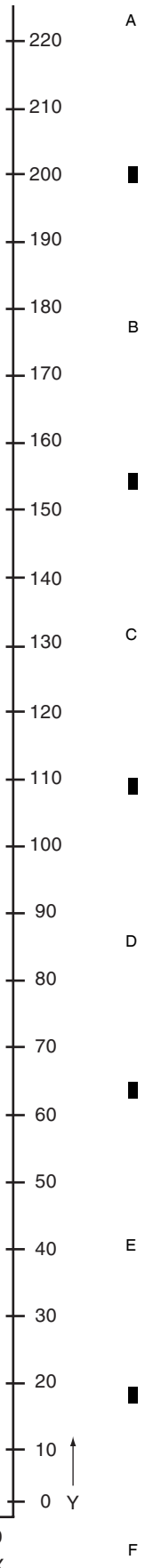
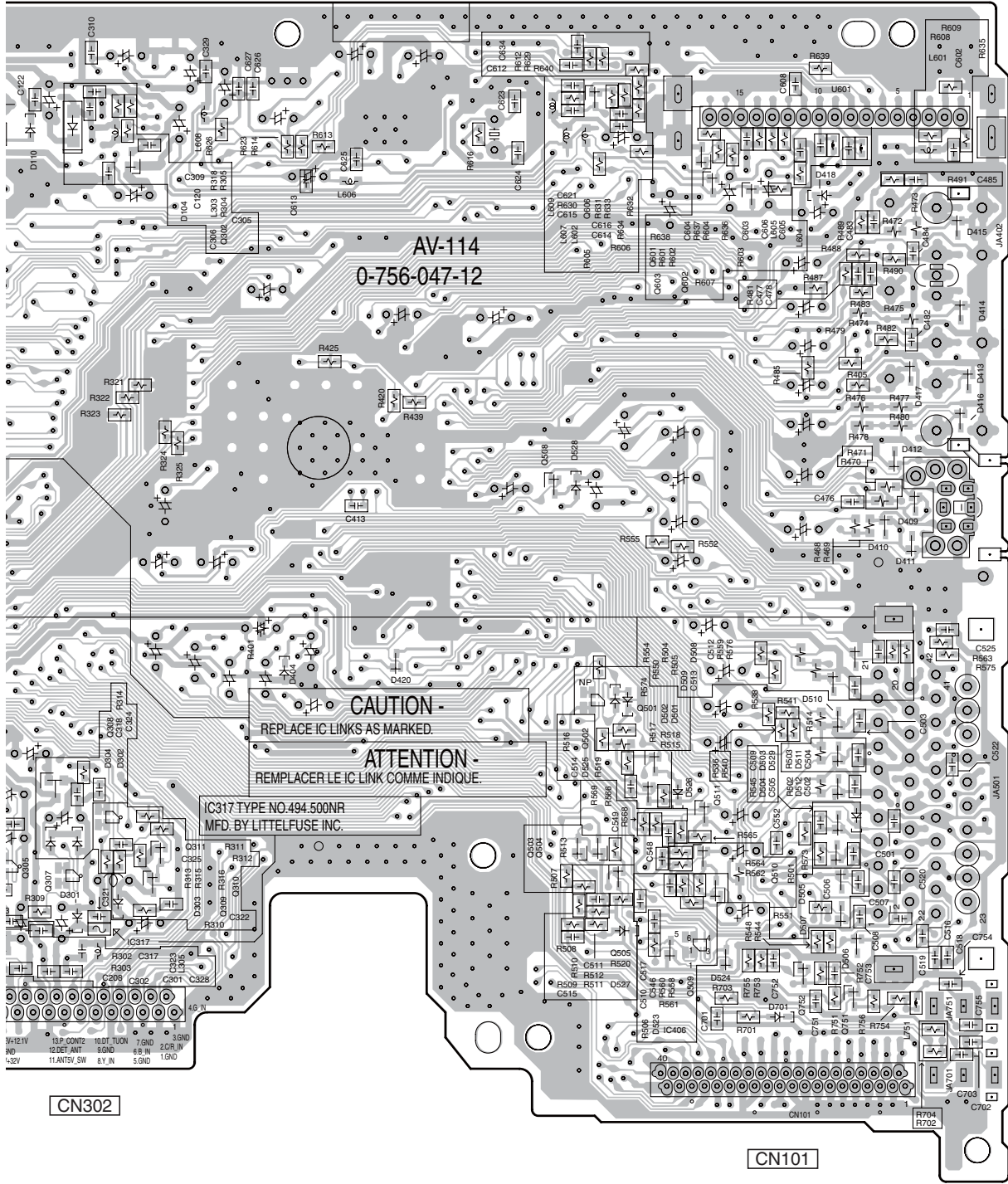

11.2 SERVICE FLKY ASSY

SIDE A

B SERVICE FLKY ASSY
 (VXX3259 : DVR-LX60)
 (VXX3226 : DVR-550H-S, DVR-550H-AV)

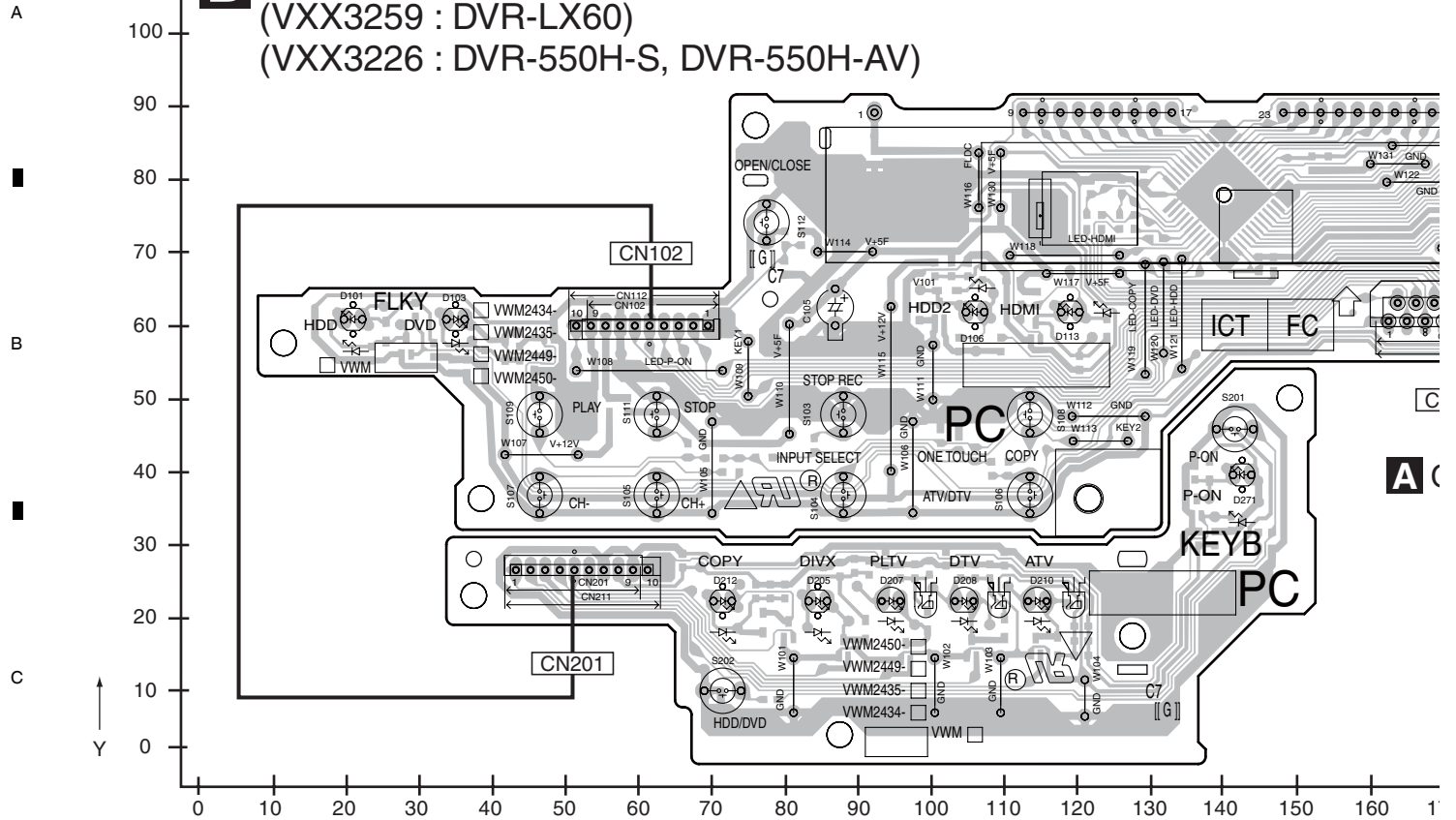

SIDE B

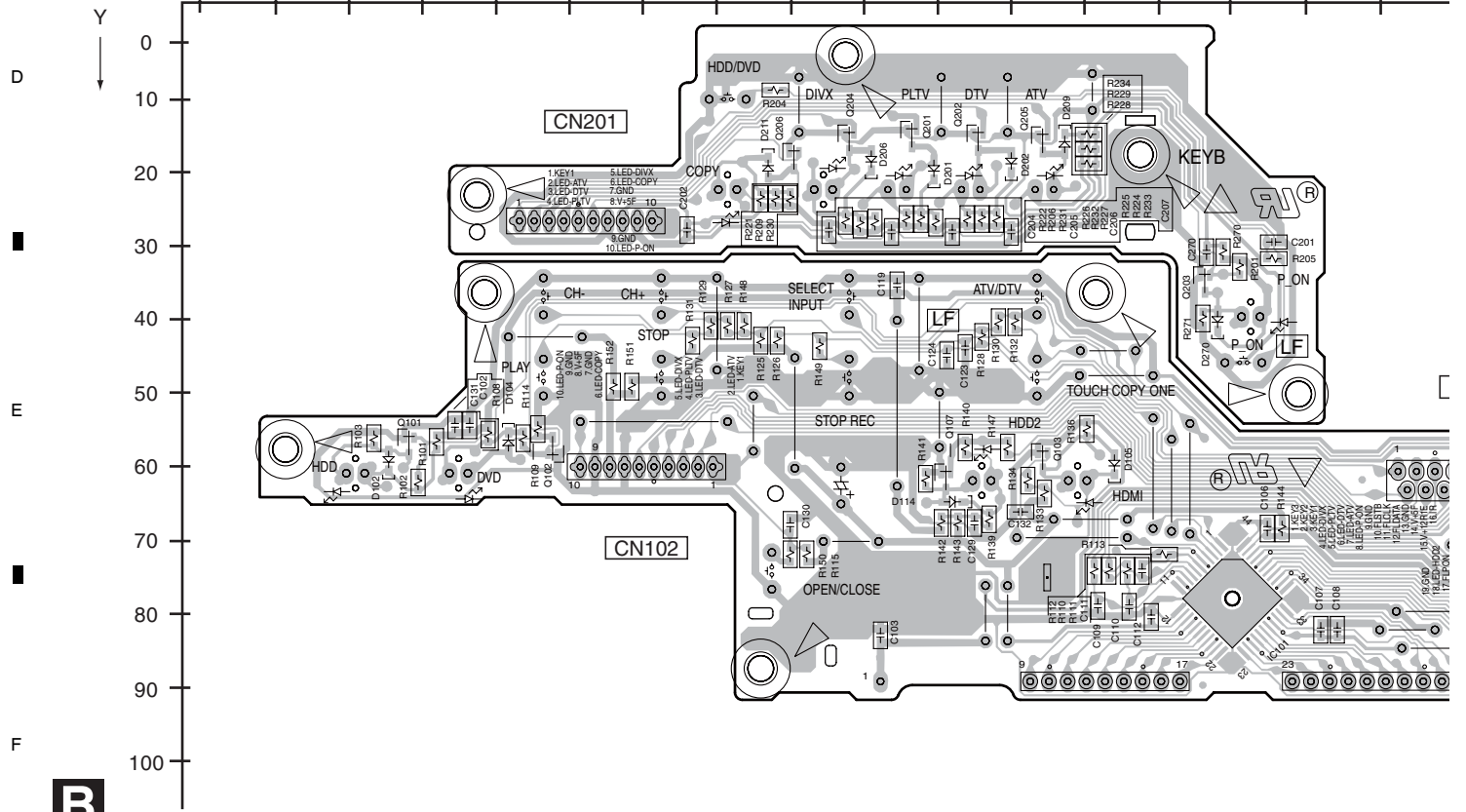

SIDE A

A

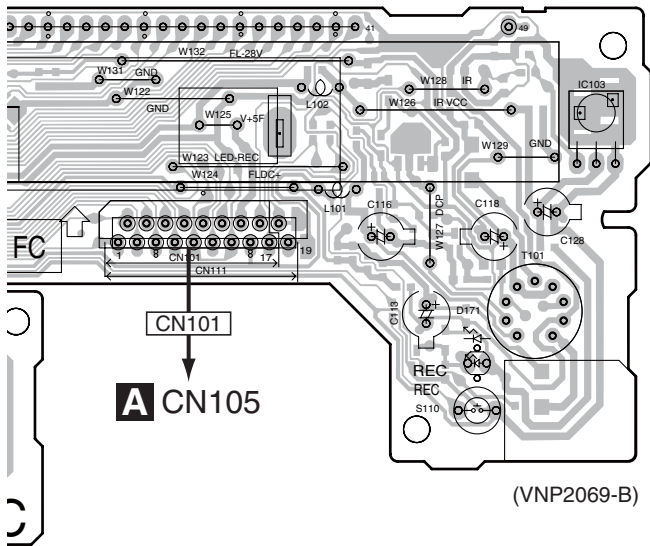

B

C

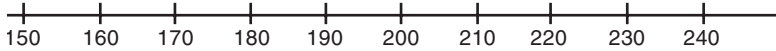

SIDE B

D

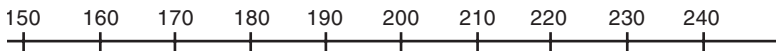

E

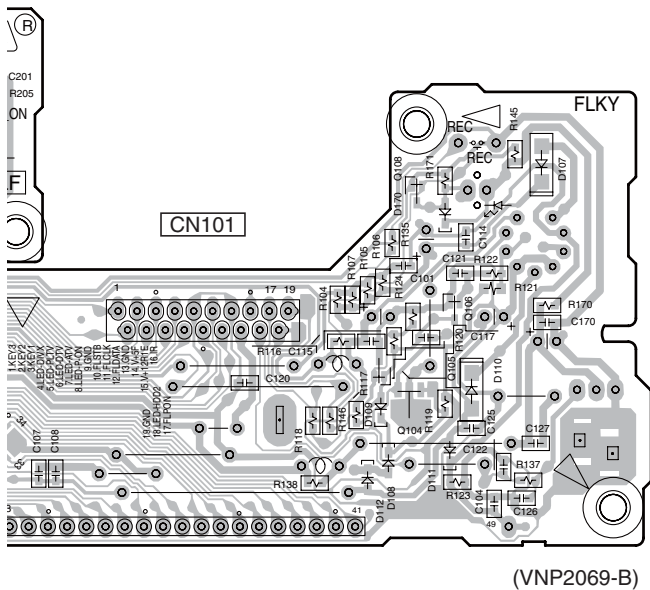

F

B

11.3 SERVICE FRJB ASSY

SIDE A

SIDE A

C SERVICE FRJB ASSY
(VXX3227)

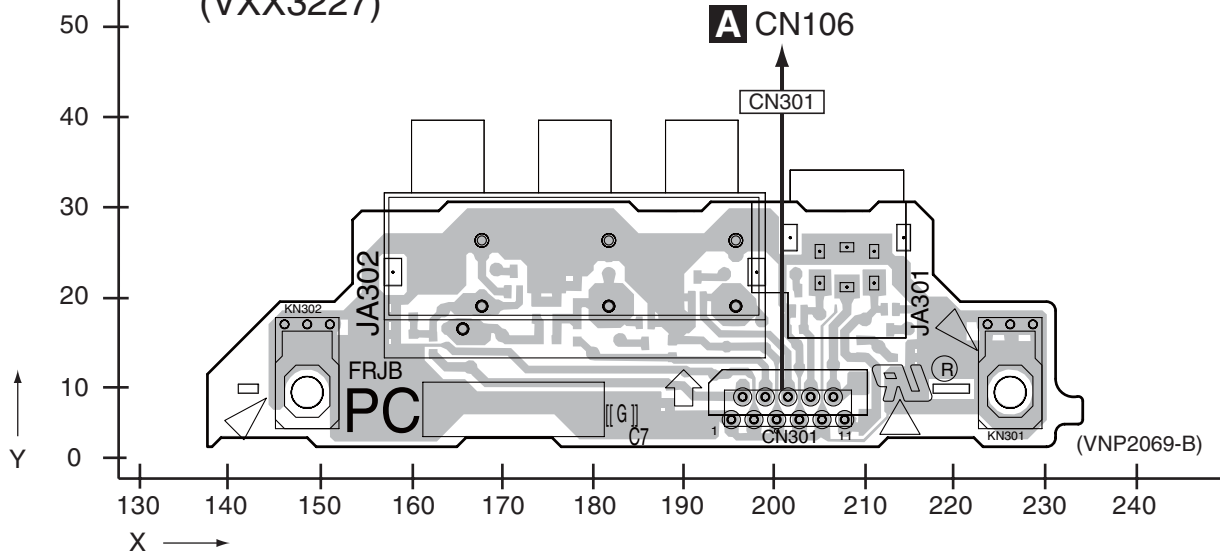

SIDE B

SIDE B

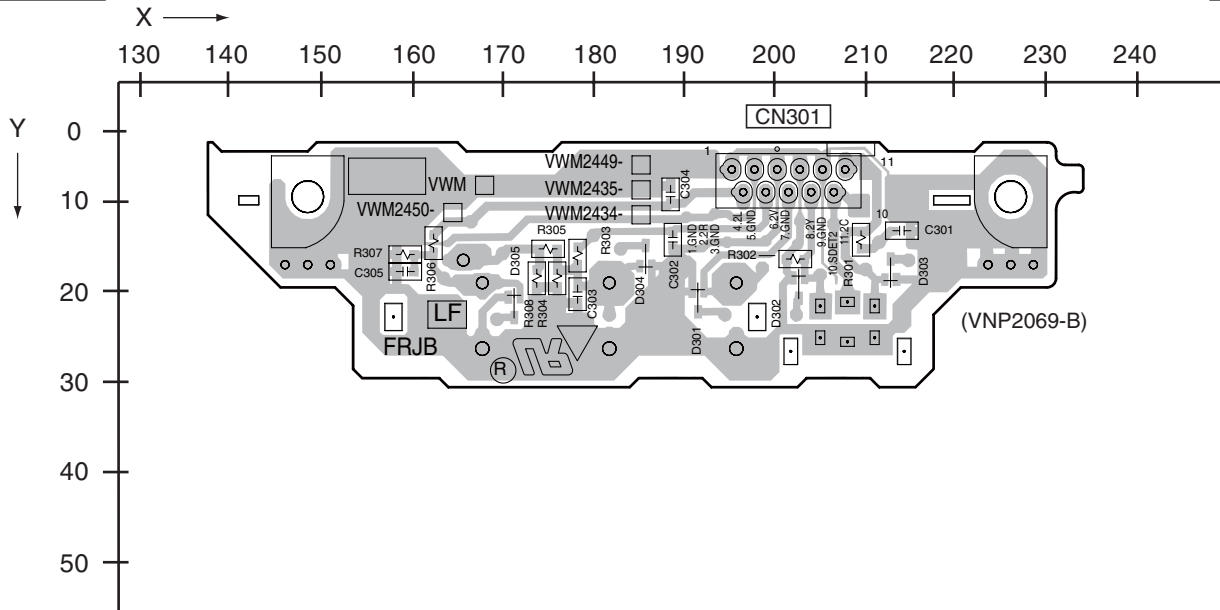

C

C

■

5

■

6

■

7

■

8

■

A

■

B

■

C

■

D

■

E

■

F

■

5

■

6

DVR-LX60

■

7

■

8

■

11.4 SERVICE MAIN ASSY

SIDE A

D SERVICE MAIN ASSY
 (VXX3241 : DVR-LX60)
 (VXX3240 : DVR-550H-S, DVR-550H-AV)

A CN101

- IC Q
- Q3701
- Q3301 Q3303
- IC3706
- IC4551 IC3202 IC4552 IC3701
- IC3201
- IC4511 Q3302 Q3304
- Q2502
- Q1811 Q2505 Q2504 Q2503
- IC5602
- Q5810
- IC1001 IC4562 IC5802
- Q5805
- Q5809
- IC5801
- IC5203 IC5202
- IC1221
- IC1302
- IC5204
- IC4521
- IC3707
- IC4502

TO HDD
CN5604

CN2301

CN4701

CN4501

E CN104

DVR-LX60

SIDE A

A

B

C

D

E

F

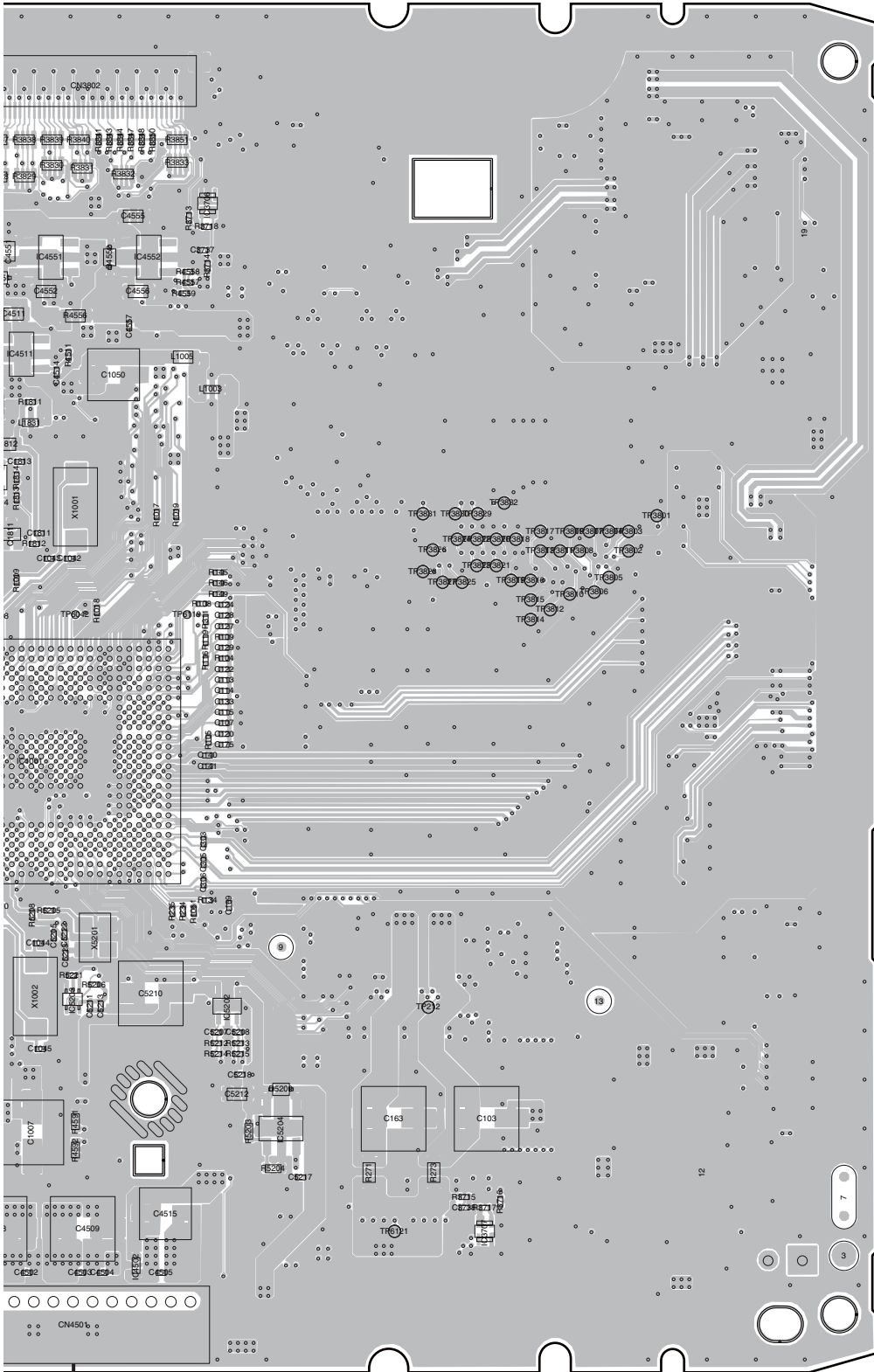

CN4501

G CN201

(VNP2056-C)

DVR-LX60

D

SIDE B

D SERVICE MAIN ASSY
 (VXX3241 : DVR-LX60)
 (VXX3240 : DVR-550H-S, DVR-550H-AV)

A

B

C

D

E

F

IC	Q
IC3702	
	Q3305
IC501	Q4581 Q3307
IC3101	
IC3203	
IC4571	
IC3102	
IC1301	Q3306 Q3308
IC1102	
	Q1801
	Q102
IC5103	
IC4561	Q5808
	Q5801
	Q5802
	Q5804
IC200	Q5201
	Q5701
IC1201	IC5701
IC4541	IC201
IC4591	
IC4531	
IC4701	
IC4703	
IC4501	
IC4702	

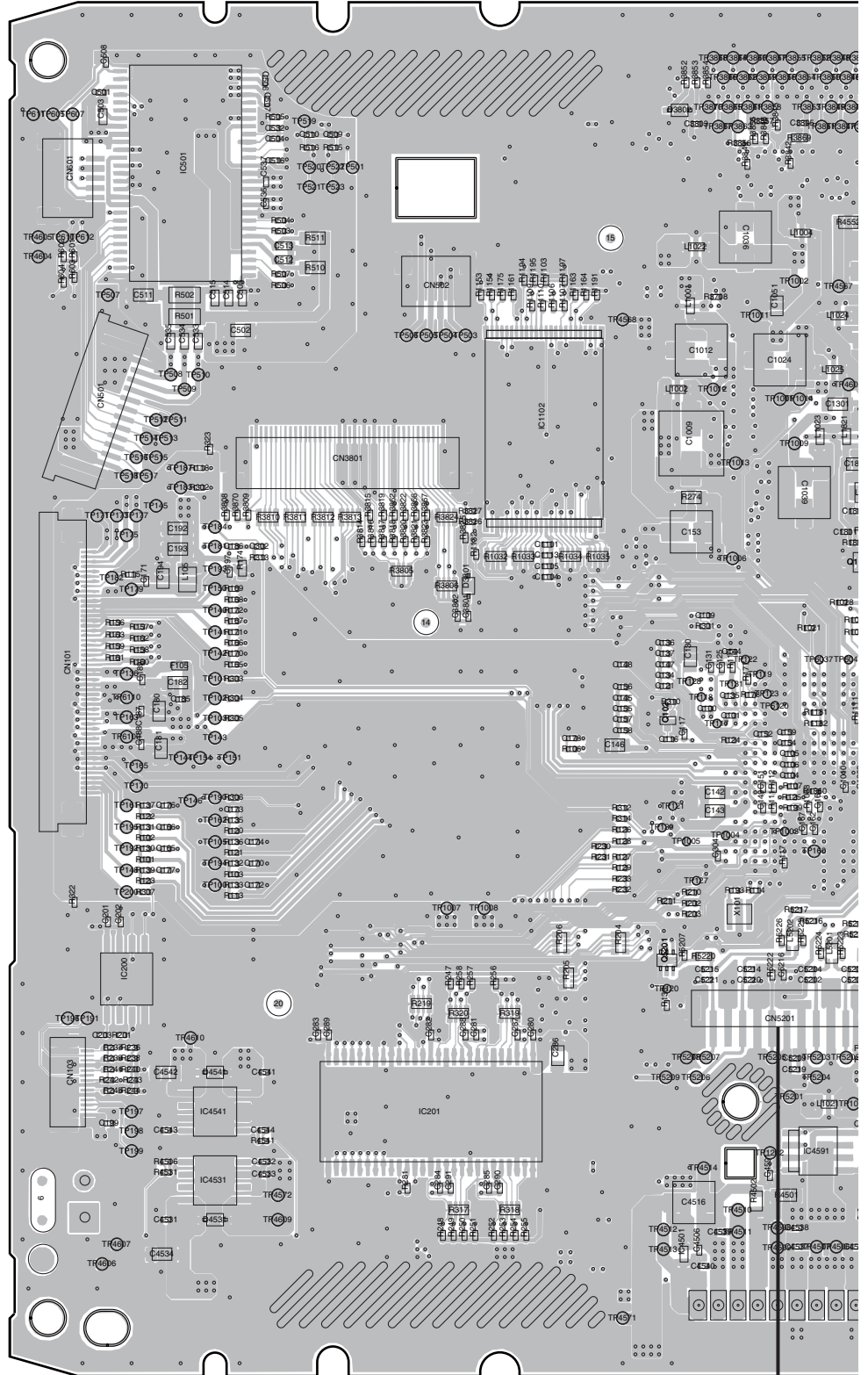

D

F CN902

CN5201

DVR-LX60

SIDE B

A

B

C

D

E

F

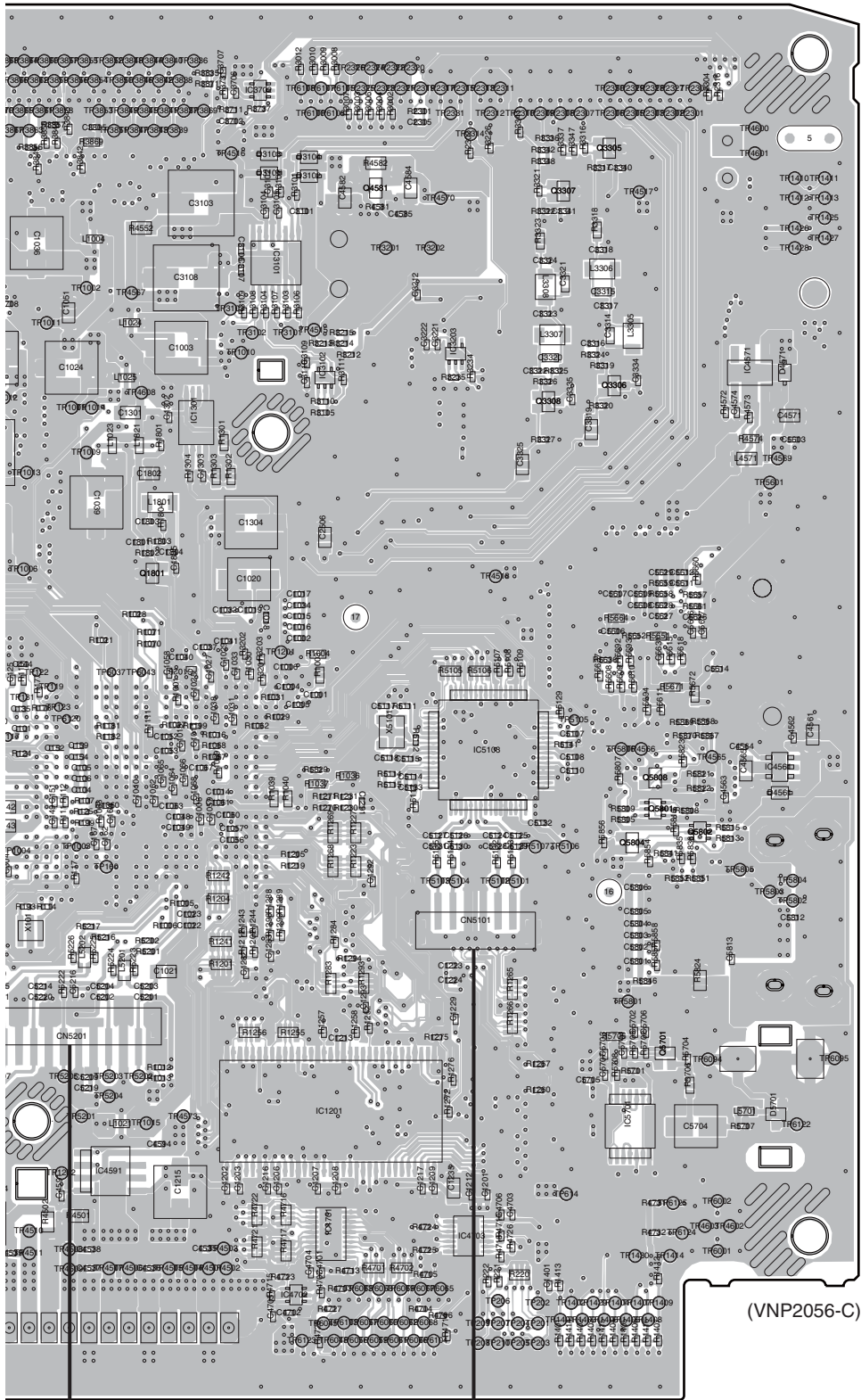

(VNP2056-C)

CN5201

CN5101

F CN901

DVR-LX60

D

SIDE A

A

B

C

D

E

F

D CN4701

CN104

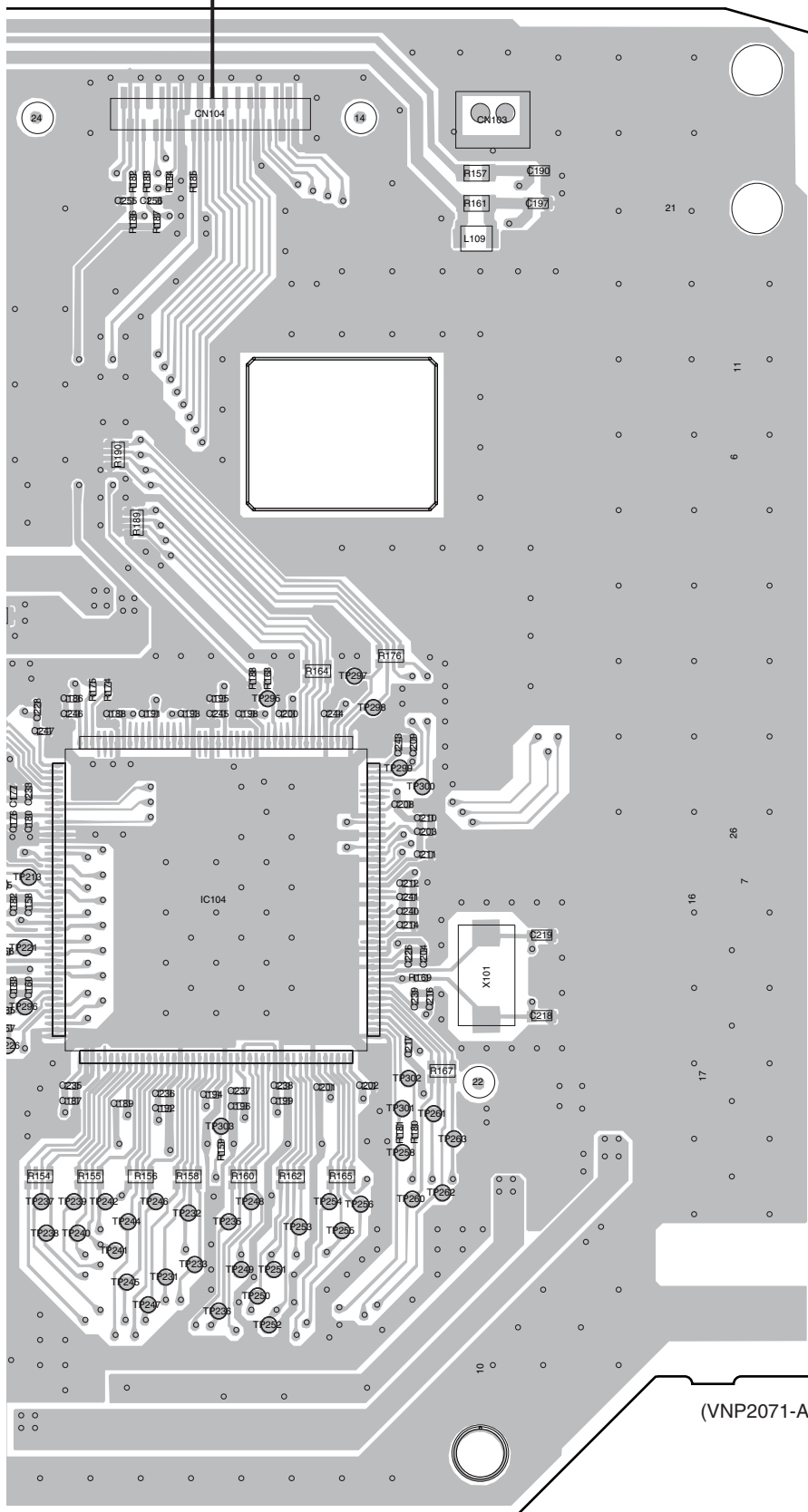

(VNP2071-A)

SIDE B

E VDEC ASSY
(VWV2304)

A

CN104

B

C

D

E

F

IC Q

IC102

Q103
Q107

Q102

IC105

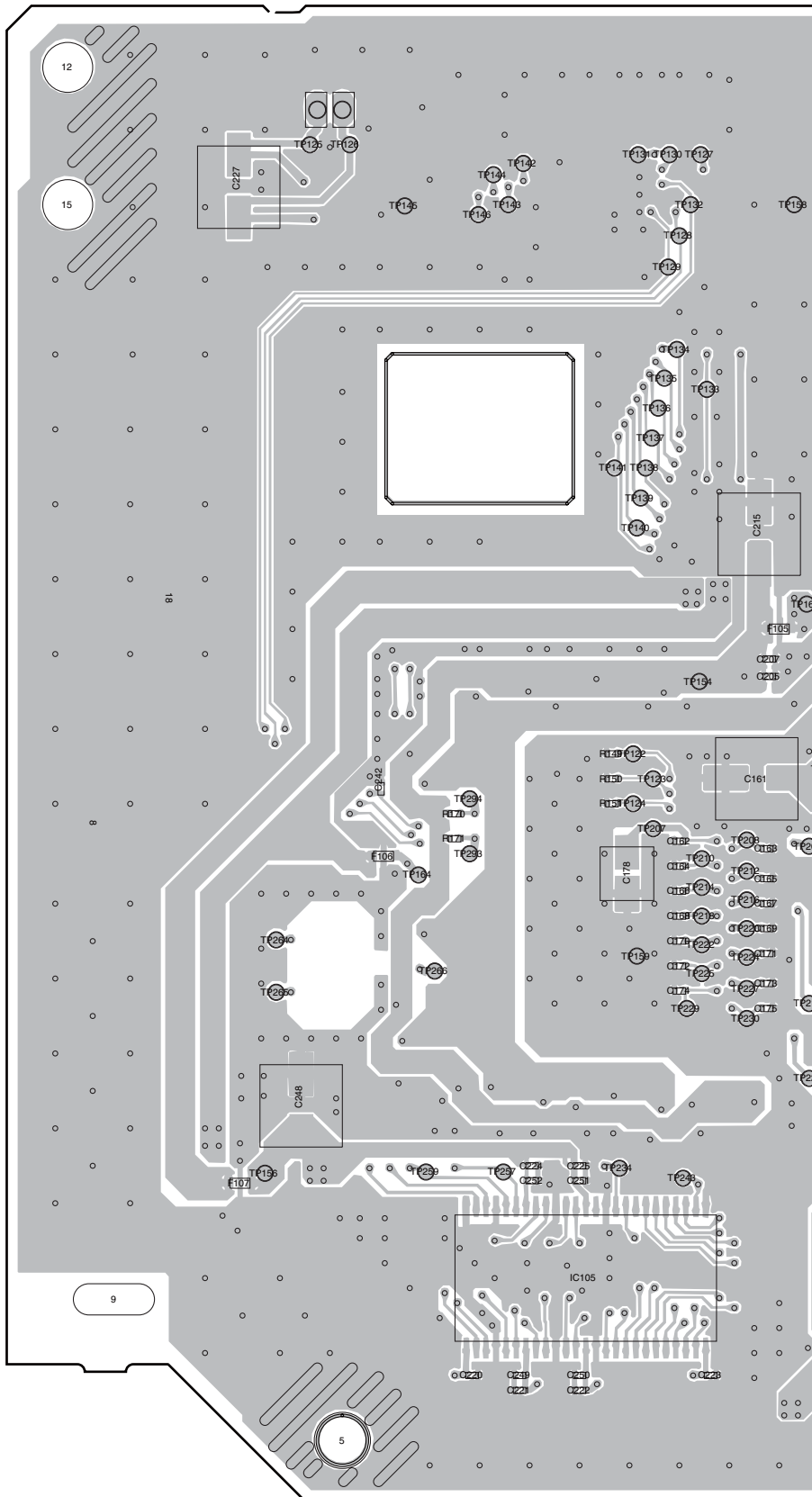

E

A
B
C
D
E
F

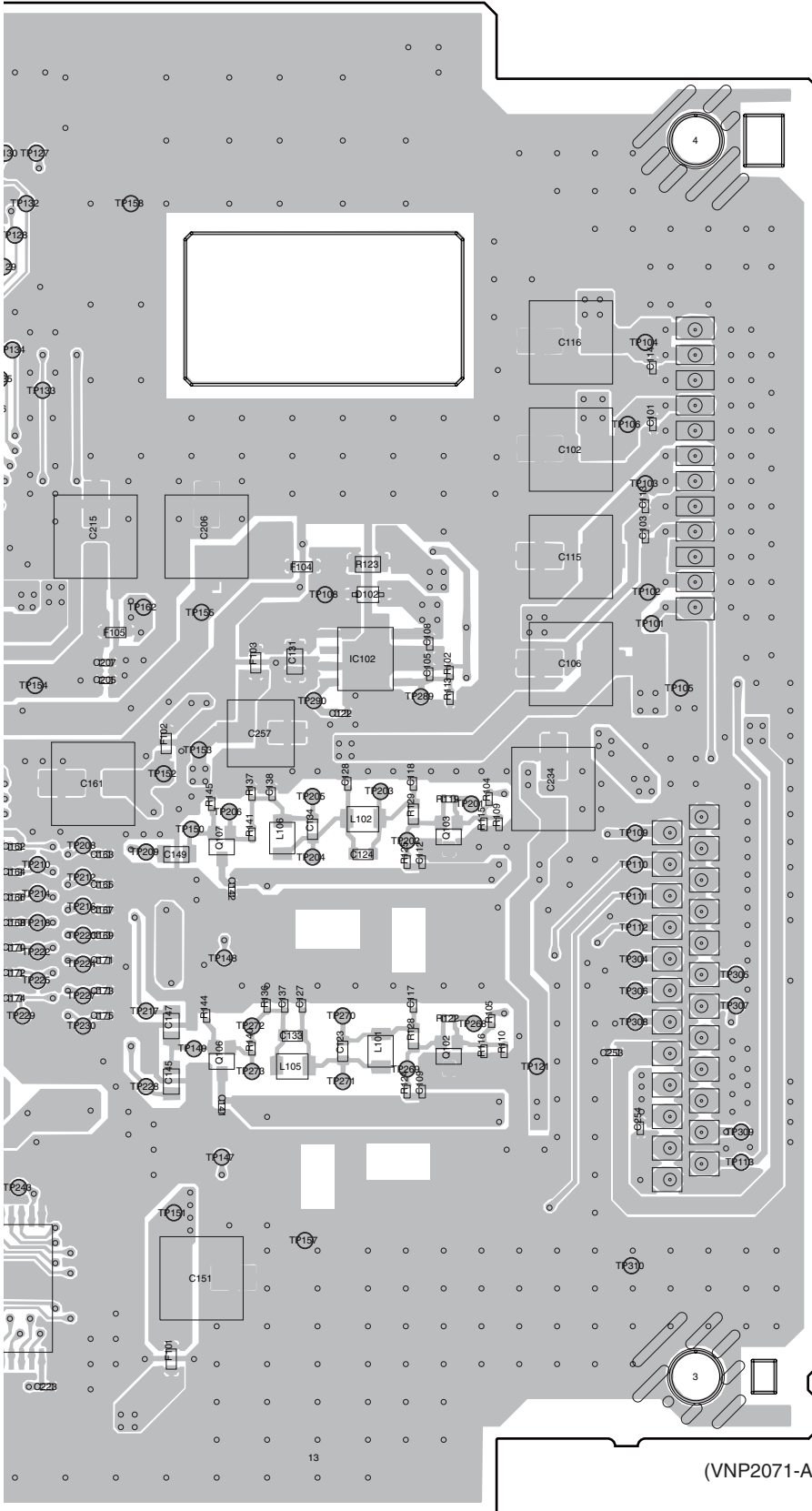

(VNP2071-A)

11.6 SERVICE DVUB ASSY

SIDE A

SIDE A

F SERVICE DVUB ASSY
 (VXX3231 : DVR-LX60)
 (VXX3232 : DVR-550H-S, DVR550H-AV)

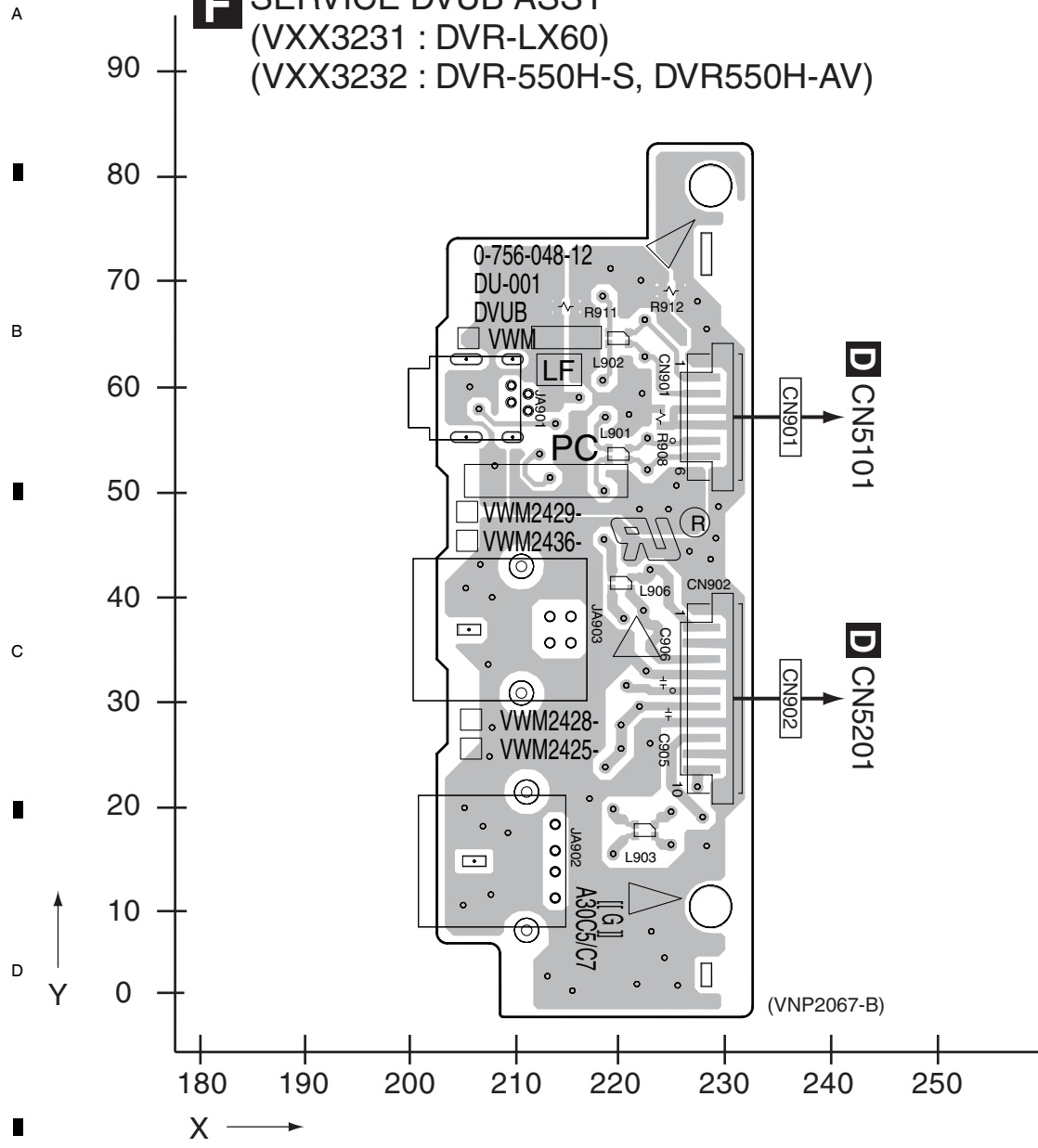

F

F

SIDE B

SIDE B

F SERVICE DVUB ASSY
 (VXX3231 : DVR-LX60)
 (VXX3232 : DVR-550H-S, DVR550H-AV)

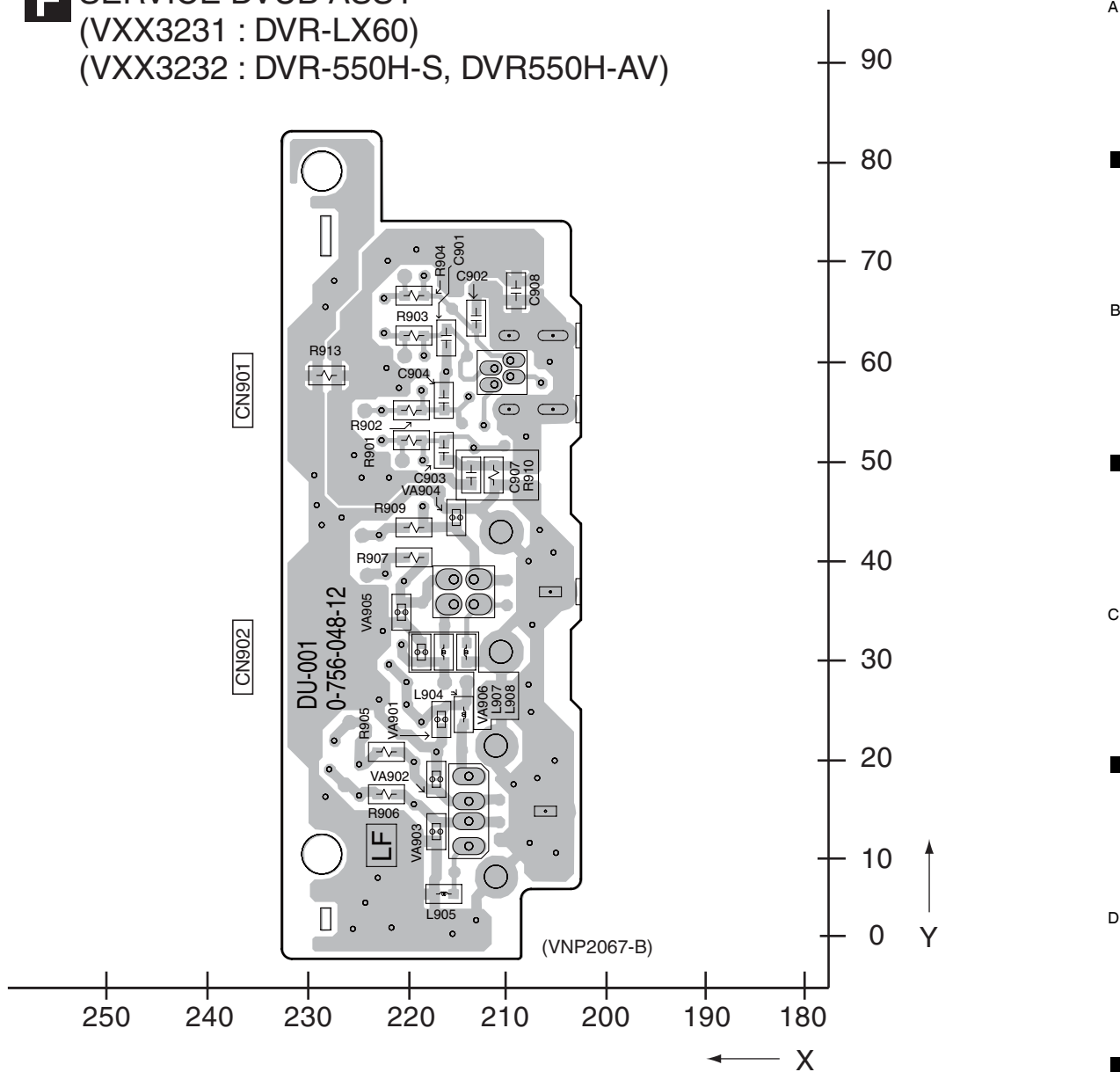

F

F

11.7 POWER SUPPLY ASSY

SIDE A

POWER SUPPLY ASSY (VWR1406)

SIDE A

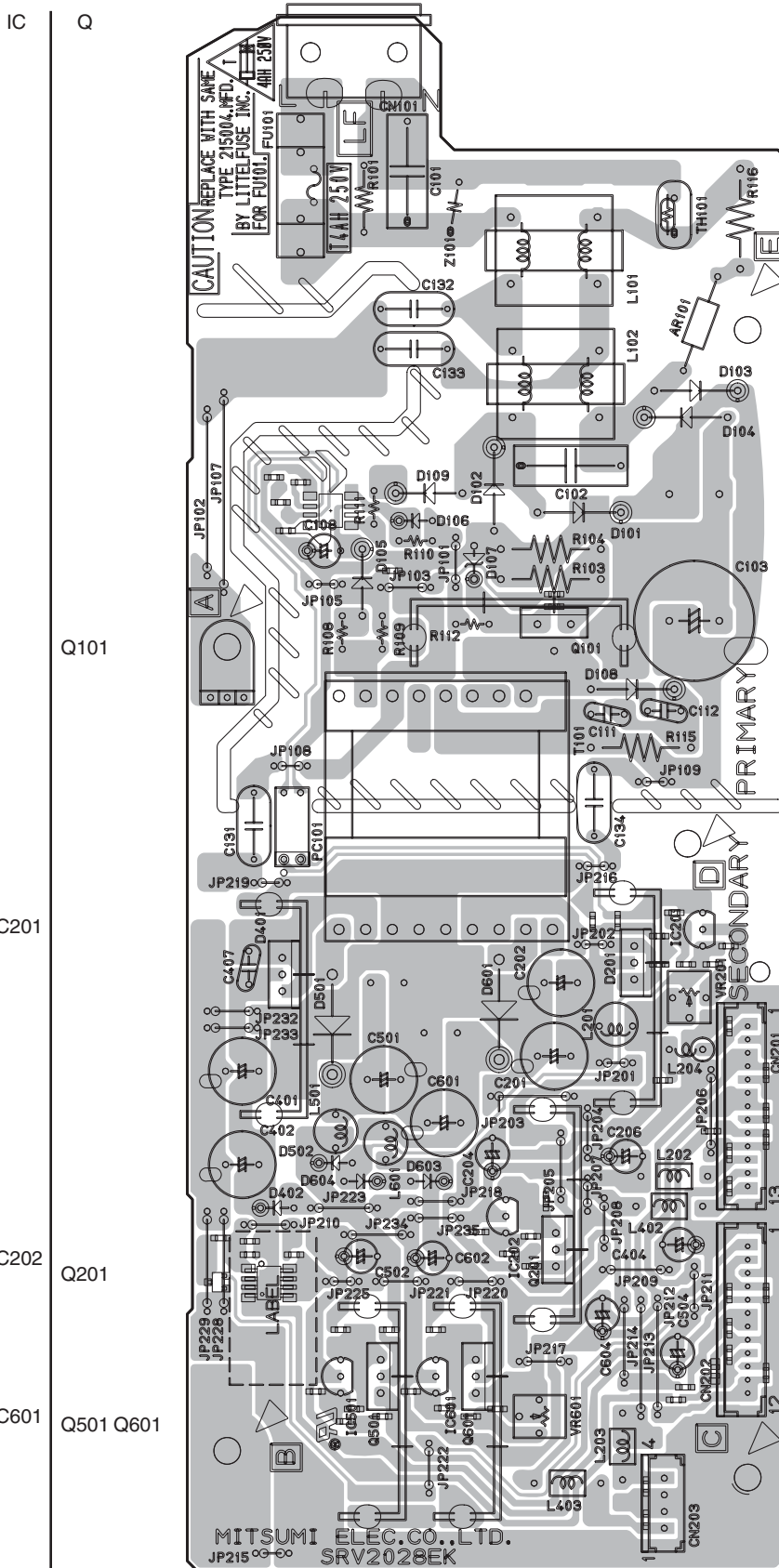

MITSUMI ELEC.CO.,LTD.
JP215 SRV2028EK

DVR-LX60

SIDE B

G POWER SUPPLY ASSY (VWR1406)

SIDE B

A

B

C

D

E

F

IC Q

IC101

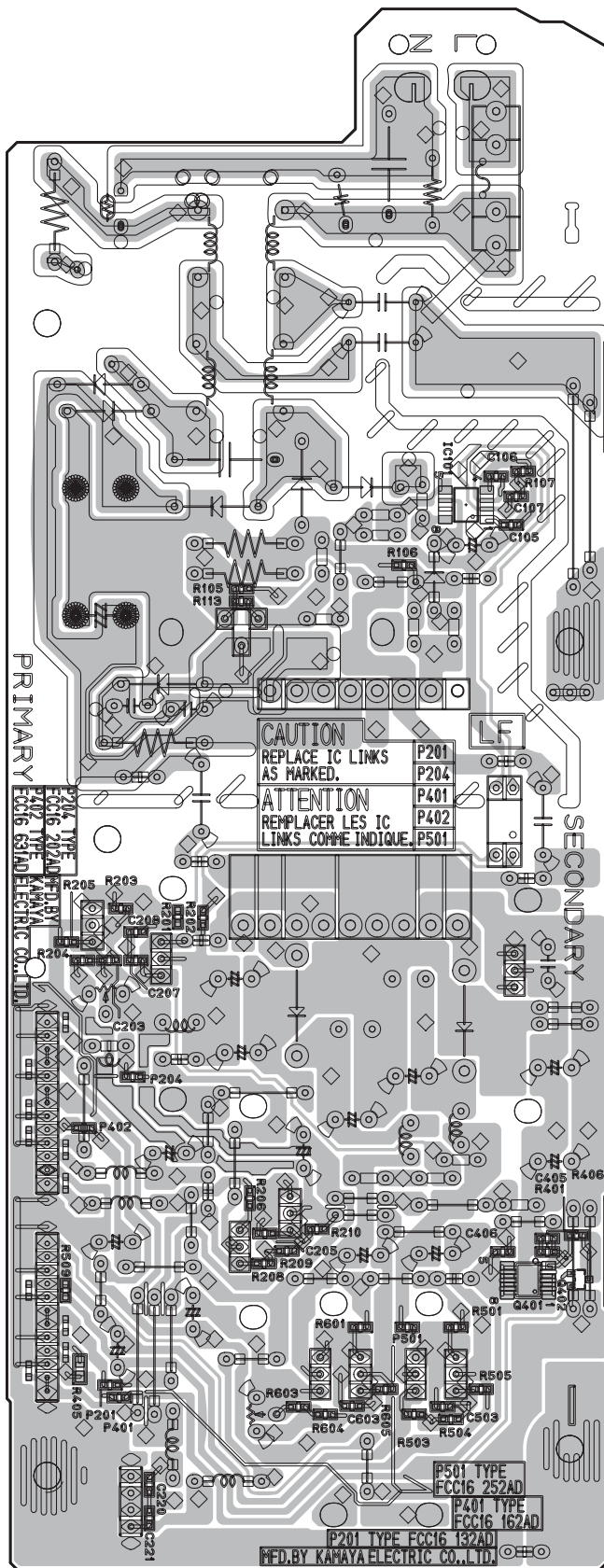

G

G

12. PCB PARTS LIST

NOTES: ● Parts marked by "NSP" are generally unavailable because they are not in our Master Spare Parts List.

● The Δ mark found on some component parts indicates the importance of the safety factor of the part. Therefore, when replacing, be sure to use parts of identical designation.

● When ordering resistors, first convert resistance values into code form as shown in the following examples.

Ex.1 When there are 2 effective digits (any digit apart from 0), such as 560 ohm and 47k ohm (tolerance is shown by J=5%, and K=10%).

560 Ω \rightarrow 56 x 10¹ \rightarrow 561 RD1/4PU567J
 47k Ω \rightarrow 47 x 10³ \rightarrow 473 RD1/4PU473J
 0.5 Ω \rightarrow R50 RN2HR50K
 1 Ω \rightarrow 1R0 RS1P1R0K

Ex.2 When there are 3 effective digits (such as in high precision metal film resistors).

5.62k Ω \rightarrow 562 x 10¹ \rightarrow 5621 RN1/4PC5627F

● Meaning of the figures and others in the parentheses in the parts list.

Example) IC 301 is on the point (face A, 91 of x-axis, and 111 of y-axis) of the corresponding PC board.

IC 301 (A, 91, 111) IC NJM2068V

Mark No.	Description	Part No.	Mark No.	Description	Part No.
----------	-------------	----------	----------	-------------	----------

LIST OF ASSEMBLIES					
NSP	1.. TUJB ASSY (DVR-LX60)	VWM2428	IC 601 (A,118,174)	MULTI SOUND DECODER	MSP3417G
NSP	1.. TUJB ASSY (DVR-550H-S, DVR-550H-AV)	VWM2429	Q 101 (A,218,157)	DIGITAL TRANSISTOR	DTC124EUA
	2.. SERVICE TUSB ASSY	VXX3230	Q 102 (A,184,154)	TRANSISTOR	2SC4081
	2.. SERVICE DVUB ASSY (DVR-LX60)	VXX3231	Q 103 (A,177,121)	TRANSISTOR	UMD2N
	2.. SERVICE DVUB ASSY (DVR-550H-S, DVR-550H-AV)	VXX3232	Q 104 (A,192,110)	TRANSISTOR	UMD2N
NSP	1.. FLKB ASSY (DVR-LX60)	VWM2449	Q 105 (A,189,109)	TRANSISTOR	2SD2114K
NSP	1.. FLKB ASSY (DVR-550H-S, DVR-550H-AV)	VWM2434	Q 108 (A,210,106)	DIGITAL TRANSISTOR	DTC124EUA
	2.. SERVICE FLKY ASSY (DVR-LX60)	VXX3259	Q 110 (A,194,103)	DIGITAL TRANSISTOR	DTA143EUA
	2.. SERVICE FLKY ASSY (DVR-550H-S, DVR-550H-AV)	VXX3226	Q 111 (A,191,97)	TRANSISTOR	2SC4081
	3.. FLKY ASSY		Q 112 (A,196,100)	TRANSISTOR	2SC4081
	3.. KEYB ASSY		Q 201 (B,195,64)	TRANSISTOR	2SD2114K
	2.. SERVICE FRJB ASSY	VXX3227	Q 301 (A,155,170)	TRANSISTOR	UMD2N
			Q 302 (B,158,171)	TRANSISTOR	2SC4081
			Q 303 (A,153,183)	TRANSISTOR	UMD2N
			Q 304 (A,159,180)	TRANSISTOR	2SD2153
			Q 305 (B,177,58)	TRANSISTOR	UMD2N
			Q 306 (B,184,65)	TRANSISTOR	2SC2411K
			Q 307 (B,167,57)	TRANSISTOR	UMD2N
			Q 308 (B,170,71)	TRANSISTOR	2SC2411K
			Q 309 (B,155,55)	TRANSISTOR	2SC5876
			Q 310 (B,153,60)	TRANSISTOR	2SC4081
			Q 311 (B,161,66)	CHIP TRANSISTOR	HN1A01FU
			Q 401 (A,143,148)	DIGITAL TRANSISTOR	DTC124EUA
			Q 402 (A,109,101)	TRANSISTOR	2SD2114K
			Q 403 (A,120,99)	TRANSISTOR	2SA1576A
			Q 404 (A,44,147)	TRANSISTOR	UMD2N
			Q 406 (A,42,137)	TRANSISTOR	2SD2114K
			Q 407 (A,42,154)	TRANSISTOR	2SD2114K
			Q 408 (A,110,94)	TRANSISTOR	2SC4081
			Q 409 (A,116,87)	TRANSISTOR	2SC4081
			Q 410 (A,115,92)	TRANSISTOR	2SC4081
			Q 411 (A,110,90)	TRANSISTOR	UMD2N
			Q 412 (A,122,84)	DIGITAL TRANSISTOR	DTC124EUA
			Q 413 (A,117,97)	DIGITAL TRANSISTOR	DTC124EUA
			Q 501 (B,84,85)	TRANSISTOR	UMH1N
			Q 502 (B,75,75)	TRANSISTOR	2SA1576A
			Q 503 (B,87,62)	TRANSISTOR	2SC4081
			Q 504 (B,84,62)	TRANSISTOR	2SC4081
			Q 505 (B,80,56)	TRANSISTOR	2SC4081
			Q 506 (A,57,81)	DUAL CHIP TRANSISTOR	HN1C03FU
			Q 507 (A,58,94)	DUAL CHIP TRANSISTOR	HN1C03FU
			Q 508 (B,91,119)	CHIP DIGITAL TRANS.	DTA124EUA

Mark No.	Description	Part No.
----------	-------------	----------

A SERVICE TUSB ASSY

MISCELLANEOUS

IC 101 (A,201,131)	MICROCOMPUTER IC	PMC020A8
IC 102 (A,225,166)	RESET IC	BD4846G
IC 103 (A,177,132)	RESET IC	BU4220G
IC 104 (A,175,152)	IC	TC7MB3257FK
Δ IC 150 (B,229,147)	FUSE	CEK1278
Δ IC 317 (B,163,48)	FUSE	CEK1278
IC 401 (A,124,124)	IC FOR DVD REC	HA118326APFR
IC 402 (A,149,100)	OP-AMP IC	BA4560RF
IC 403 (A,123,93)	VIDEO SW IC	MM1503XN
IC 406 (B,67,46)	IC	TC7S66FU

Mark No.	Description	Part No.
Q 509 (B,65,55)	TRANSISTOR	2SC4081
Q 510 (B,67,60)	TRANSISTOR	2SC4081
Q 511 (B,67,67)	TRANSISTOR	2SA1576A
Q 601 (B,67,172)	TRANSISTOR	2SA1576A
Q 602 (B,59,165)	TRANSISTOR	2SA1576A
Q 604 (A,139,174)	TRANSISTOR	2SA1576A
Q 605 (A,139,169)	TRANSISTOR	2SA1576A
Q 606 (B,84,181)	TRANSISTOR	2SC4081
Q 751 (B,43,37)	TRANSISTOR	2SA1576A
Q 752 (B,51,41)	TRANSISTOR	2SC4081
D 101 (A,221,164)	DIODE	1SS355
D 102 (A,218,163)	DIODE	1SS355
D 103 (A,177,59)	DIODE	1SS355
D 104 (B,167,176)	DIODE	1SR154-400
D 106 (A,176,109)	DIODE	1SS355
D 108 (A,178,126)	DIODE	DAP202U
D 201 (B,188,59)	DIODE	1SS355
D 301 (B,167,50)	DIODE	UDZS15(B)
D 302 (B,167,62)	DIODE	UDZS9R1(B)
D 303 (B,160,53)	DIODE	1SS355
D 304 (B,171,62)	DIODE	1SS355
D 401 (A,135,81)	DIODE	UDZS11(B)
D 402 (A,101,150)	DIODE	UDZS6R8(B)
D 418 (B,48,165)	DIODE	1SS355
D 419 (A,44,150)	DIODE	1SS355
D 420 (B,116,91)	DIODE	DAP202U
D 501 (B,79,85)	DIODE	UDZS5R1(B)
D 502 (B,81,85)	DIODE	UDZS5R1(B)
D 503 (B,45,65)	DIODE	UMZ6R8N
D 504 (B,46,61)	DIODE	UMZ6R8N
D 505 (B,45,56)	DIODE	UMZ6R8N
D 506 (B,42,46)	DIODE	UMZ6R8N
D 507 (B,45,51)	DIODE	UMZ6R8N
D 508 (B,43,91)	DIODE	UMZ6R8N
D 509 (B,46,87)	DIODE	UMZ6R8N
D 510 (B,45,82)	DIODE	UMZ6R8N
D 511 (B,45,76)	DIODE	UMZ6R8N
D 512 (B,45,71)	DIODE	UMZ6R8N
D 513 (A,46,65)	DIODE	UMZ6R8N
D 514 (A,44,59)	DIODE	UMZ6R8N
D 515 (A,44,49)	DIODE	UMZ6R8N
D 516 (A,44,55)	DIODE	UMZ6R8N
D 517 (A,44,52)	DIODE	UMZ6R8N
D 518 (A,44,72)	DIODE	UMZ6R8N
D 519 (A,45,78)	DIODE	UMZ6R8N
D 520 (A,46,83)	DIODE	UMZ6R8N
D 521 (A,44,90)	DIODE	UMZ6R8N
D 522 (A,38,101)	DIODE	UMZ6R8N
D 523 (B,72,45)	DIODE	DAN217U
D 524 (B,63,44)	DIODE	DAN217U
D 526 (B,71,70)	DIODE	1SS355
D 527 (B,80,48)	DIODE	1SS355
D 528 (B,87,119)	DIODE	1SS355
D 701 (B,55,34)	DIODE	1SS355
L 102 (A,200,88)	AXIAL INDUCTOR	LAU470J
L 201 (A,191,57)	RADIAL INDUCTOR	ATH1109
L 303 (B,161,175)	INDUCTOR	CTF1399
L 304 (A,158,56)	RADIAL INDUCTOR	LFCA331J
L 305 (B,163,45)	INDUCTOR	CTF1399
L 401	INDUCTOR	CTF1388

Mark No.	Description	Part No.
L 402	INDUCTOR	CTF1388
L 403	INDUCTOR	CTF1388
L 404	INDUCTOR	CTF1388
L 405	INDUCTOR	CTF1388
L 501	INDUCTOR	CTF1388
L 502	INDUCTOR	CTF1388
L 601 (B,31,173)	INDUCTOR	CTF1399
L 602 (B,86,175)	INDUCTOR	CTF1399
L 604 (B,42,173)	INDUCTOR	CTF1306
L 605 (B,46,173)	INDUCTOR	CTF1306
L 606 (B,123,168)	INDUCTOR	CTF1399
L 607 (B,89,175)	COIL	LCYA101J2520
L 608 (B,146,178)	INDUCTOR	CTF1399
L 609 (B,91,180)	INDUCTOR	LCYA100J2520
L 751 (B,33,37)	INDUCTOR	CTF1306
JA 402 (A,17,146)	9P PIN JACK	VKB1250
JA 501 (A,18,70)	RGB CONNECTOR	VKB1249
JA 701 (A,18,25)	JACK REMOCON JACK	RKN1004
JA 751 (A,18,36)	JACK REMOCON JACK	RKN1004
KN 101 (A,131,184)	WRAPPING TERMINAL	VNF1084
KN 102 (A,192,46)	WRAPPING TERMINAL	VNF1084
X 101 (A,204,157)	CRYSTAL OSCILLATOR	CSS1653
X 102 (A,210,156)	CRYSTAL RESONATOR (32 kHz)	VSS1197
X 601 (A,100,173)	CERAMIC RESONATOR (18.432 MHz)	VSS1189
CN 101 (A,35,23)	40P CONNECTOR	VKN2007
CN 103 (A,235,159)	9P FFC CONNECTOR	VKN2015
CN 105 (A,232,148)	CONNECTOR	HLEM17S-1
CN 106 (A,238,107)	CONNECTOR	HLEM11S-1
CN 302 (A,151,35)	CONNECTOR 401 2P 4PIN MINIDIN(S)	HLEM24R-1 AKP1234
U 601 (A,26,178)	TV TUNER PACK	VXF1146

RESISTORS

R 101 (A,187,125)	RS1/16S101J	
R 102 (A,182,123)	RS1/16S101J	
R 103 (A,187,118)	RS1/16S101J	
R 104 (A,224,158)	RS1/16S473J	
R 105 (A,215,149)	RS1/16S101J	
R 106 (A,221,158)	RS1/16S0R0J	
R 107 (A,224,159)	RS1/16S103J	
R 109 (A,212,144)	RS1/16S331J	
R 110 (A,211,144)	RS1/16S101J	
R 111 (A,212,149)	RS1/16S101J	
R 112 (A,222,161)	RS1/16S103J	
R 113 (A,219,161)	RS1/16S0R0J	
R 116 (B,208,153)	RS1/16S0R0J	
R 117 (A,204,145)	RS1/16S105J	
R 118 (B,201,150)	RS1/16S0R0J	
R 120 (A,197,163)	CARBON FILM RESISTOR	RD1/4PU153J
R 123 (A,197,149)	RS1/16S101J	
R 124 (A,197,146)	RS1/16S101J	
R 125 (A,196,83)	RS1/16S101J	
R 126 (A,194,147)	RS1/16S101J	
R 127 (A,192,151)	RS1/16S103J	
R 129 (A,195,149)	RS1/16S101J	
R 130 (B,235,155)	RS1/16S0R0J	
R 131 (A,189,154)	RS1/16S472J	
R 132 (A,190,149)	RS1/16S682J	

	<u>Mark No.</u>	<u>Description</u>	<u>Part No.</u>	<u>Mark No.</u>	<u>Description</u>	<u>Part No.</u>
	R 134 (A,187,148)		RS1/16S102J	R 204 (A,182,136)		RS1/16S101J
	R 135 (A,185,152)		RS1/16S104J	R 205 (A,185,134)		RS1/16S101J
	R 136 (A,189,158)		RS1/16S102J	R 207 (A,197,104)		RS1/16S471J
A	R 137 (A,186,155)		RS1/16S101J	R 208 (A,197,106)		RS1/16S0R0J
	R 138 (A,183,160)		RS1/16S471J	R 209 (A,191,101)		RS1/16S332J
	R 139 (A,184,149)		RS1/16S682J	R 210 (A,197,108)		RS1/16S8200F
	R 140 (A,182,148)		RS1/16S101J	R 214 (A,189,93)		RS1/16S332J
	R 141 (A,182,151)		RS1/16S682J	R 215 (A,192,93)		RS1/16S681J
	R 142 (A,181,151)		RS1/16S101J	R 216 (A,193,95) CHIP RESISTOR		RS1/16S7500F
	R 143 (A,183,145)		RS1/16S101J	R 217 (A,196,93)		RS1/16S102J
	R 144 (A,185,139)		RS1/16S0R0J	R 218 (A,177,56)		RS1/10S0R0J
	R 145 (A,180,131)		RS1/16S103J	R 219 (B,190,74)		RS1/16S332J
	R 146 (A,187,126)		RS1/16S101J	R 220 (B,193,71)		RS1/16S222J
B	R 147 (A,191,112)		RS1/16S102J	R 221 (A,178,145)		RS1/16S101J
	R 148 (A,184,126)		RS1/16S101J	R 222 (A,184,140)		RS1/16S0R0J
	R 149 (A,188,119)		RS1/16S0R0J	R 223 (A,174,157)		RS1/16S101J
	R 150 (A,190,117)		RS1/16S0R0J	R 224 (A,177,156)		RS1/16S101J
	R 151 (A,194,117)		RS1/16S0R0J	R 228 (A,196,160)		RS1/16S0R0J
	R 152 (A,184,127)		RS1/16S0R0J	R 233 (B,219,89)		RS1/16S104J
	R 153 (A,198,113)		RS1/16S101J	R 251 (B,184,44)		RS1/10S0R0J
	R 154 (B,199,113)		RS1/16S101J	R 301 (A,143,80)		RS1/10S0R0J
	R 155 (A,198,83)		RS1/16S101J	R 302 (B,179,47)		RS1/10S0R0J
	R 156 (A,201,116)		RS1/16S101J	R 303 (B,179,45)		RS1/10S0R0J
	R 157 (A,202,118)		RS1/16S104J	R 304 (B,159,176)		RS1/16S101J
C	R 158 (A,202,119)		RS1/16S104J	R 305 (B,158,180)		RS1/16S330J
	R 159 (A,205,117)		RS1/16S0R0J	R 306 (B,179,55)		RS1/16S330J
	R 160 (A,206,114)		RS1/16S101J	R 307 (A,160,83)		RS1/10S0R0J
	R 161 (A,201,108)		RS1/16S0R0J	R 308 (A,162,83)		RS1/10S0R0J
	R 165 (A,206,117)		RS1/16S0R0J	R 309 (B,173,51)		RS1/16S152J
	R 167 (A,207,114)		RS1/16S101J	R 310 (B,156,51)		RS1/16S472J
	R 168 (A,211,112)		RS1/16S181J	R 311 (B,155,66)		RS1/16S821J
	R 169 (A,207,101)		RS1/16S103J	R 312 (B,153,64)		RS1/16S103J
	R 171 (A,215,114)		RS1/16S101J	R 313 (B,162,59)		RS1/16S184J
	R 172 (A,216,114)		RS1/16S101J	R 314 (B,166,73)		RS1/16S223J
	R 173 (A,218,113)		RS1/16S104J	R 315 (B,160,59)		RS1/16S1003F
D	R 174 (A,217,111)		RS1/16S104J	R 316 (B,157,60)		RS1/16S2202F
	R 175 (A,219,113)		RS1/16S331J	R 318 (B,160,180)		RS1/16S0R0J
	R 176 (A,220,124)		RS1/16S102J	R 401 (B,137,96)		RS1/10S0R0J
	R 177 (A,222,126)		RS1/16S101J	R 402 (A,138,102)		RS1/16S561J
	R 178 (A,219,127)		RS1/16S101J	R 403 (A,136,103)		RS1/16S561J
	R 179 (A,222,128)		RS1/16S101J	R 404 (A,133,89)		RS1/10S0R0J
	R 180 (A,221,132)		RS1/16S101J	R 407 (A,97,126)		RS1/10S0R0J
	R 181 (A,218,133)		RS1/16S101J	R 408 (A,148,115)		RS1/16S471J
	R 182 (A,221,134)		RS1/16S101J	R 410 (A,150,110)		RS1/16S471J
	R 183 (A,218,135)		RS1/16S101J	R 412 (A,148,112)		RS1/16S471J
E	R 184 (A,221,136)		RS1/16S101J	R 413 (A,148,119)		RS1/16S471J
	R 185 (A,218,137)		RS1/16S101J	R 414 (A,145,124)		RS1/16S471J
	R 186 (A,221,138)		RS1/16S101J	R 415 (A,145,126)		RS1/16S471J
	R 188 (A,221,140)		RS1/16S331J	R 416 (A,146,127)		RS1/16S471J
	R 189 (A,221,142)		RS1/16S471J	R 417 (A,146,129)		RS1/16S471J
	R 193 (B,230,171)		RS1/16S104J	R 418 (A,146,131)		RS1/16S471J
	R 194 (B,236,171)		RS1/16S104J	R 419 (A,146,133)		RS1/16S471J
	R 195 (B,228,171)		RS1/16S104J	R 420 (B,116,133) CHIP RESISTOR		RS1/16S335J
	R 196 (B,238,171)		RS1/16S101J	R 421 (A,124,136) CHIP RESISTOR		RS1/16S335J
	R 197 (A,52,22)		RS1/16S0R0J	R 422 (A,140,113)		RS1/16S103J
	R 199 (A,209,110)		RS1/16S101J	R 425 (B,126,139)		RS1/16S104J
F	R 200 (A,221,144)		RS1/16S101J	R 428 (A,129,139)		RS1/16S0R0J
	R 201 (A,187,128)		RS1/16S0R0J	R 430 (A,133,140)		RS1/16S105J
	R 202 (A,185,137)		RS1/16S0R0J	R 431 (A,124,141)		RS1/16S105J
	R 203 (A,182,138)		RS1/16S0R0J	R 432 (A,122,144)		RS1/16S105J

5			6			7			8		
Mark No.	Description	Part No.	Mark No.	Description	Part No.	Mark No.	Description	Part No.	Mark No.	Description	Part No.
R 433	(A,106,110)	RS1/16S105J	R 517	(B,83,79)	RS1/16S152J	R 518	(B,79,80)	RS1/16S100J			
R 435	(A,105,115)	RS1/16S105J	R 519	(B,73,70)	RS1/16S563J	R 520	(B,80,53)	RS1/16S221J	A		
R 436	(A,94,132)	RS1/16S101J	R 521	(A,48,68)	CHIP TYPE RESISTOR	RS1/10S68R0F					
R 437	(A,96,132)	RS1/16S101J									
R 438	(A,96,143)	RS1/10S0R0J									
R 439	(B,113,132)	RS1/16S185J	R 522	(A,44,61)	RS1/10S3R9J	R 523	(A,45,69)	CHIP TYPE RESISTOR	RS1/10S68R0F		
R 440	(A,116,85)	RS1/16S471J	R 524	(A,43,69)	RS1/10S3R9J	R 525	(A,48,79)	CHIP TYPE RESISTOR	RS1/10S68R0F		
R 444	(A,130,147)	RS1/10S75R0F	R 526	(A,44,75)	RS1/10S3R9J						
R 445	(A,133,146)	RS1/10S75R0F									
R 447	(A,122,149)	RS1/10S75R0F									
R 448	(A,100,142)	RS1/10S0R0J	R 527	(A,47,87)	RS1/10S0R0J	R 528	(A,45,87)	RS1/10S75R0F			
R 449	(A,108,147)	RS1/10S75R0F	R 529	(A,43,81)	RS1/16S104J	R 530	(A,44,95)	CHIP TYPE RESISTOR	RS1/10S68R0F		
R 453	(A,155,102)	RS1/16S8201F	R 531	(A,44,93)	RS1/10S3R9J						B
R 454	(A,136,109)	RS1/16S1002F									
R 455	(A,121,103)	RS1/16S470J									
R 458	(A,121,109)	RS1/16S471J	R 532	(A,119,151)	RS1/10S75R0F	R 534	(A,58,76)	RS1/16S392J			
R 459	(A,124,100)	RS1/10S75R0F	R 535	(A,58,85)	RS1/16S392J	R 536	(B,54,80)	RS1/16S471J			
R 461	(A,115,95)	RS1/16S681J	R 537	(A,48,52)	RS1/16S101J						
R 462	(A,138,107)	RS1/16S1002F									
R 463	(A,143,102)	RS1/16S8201F									
R 465	(A,116,100)	RS1/16S471J	R 538	(B,56,83)	RS1/16S471J	R 539	(A,48,49)	RS1/16S101J			
R 466	(A,113,82)	RS1/10S75R0F	R 540	(B,52,80)	RS1/16S104J	R 541	(B,53,83)	RS1/16S104J			
R 468	(B,43,113)	CHIP TYPE RESISTOR	R 542	(A,47,55)	RS1/16S101J						
R 469	(B,40,113)	RS1/10S3R9J									
R 470	(B,38,117)	CHIP TYPE RESISTOR	RS1/10S68R0F								C
R 471	(B,37,119)	RS1/10S3R9J	R 543	(A,47,59)	RS1/16S101J	R 544	(B,47,46)	RS1/16S101J			
R 472	(B,36,160)	CHIP TYPE RESISTOR	R 545	(B,48,60)	RS1/16S101J	R 546	(A,51,68)	RS1/16S104J			
R 473	(B,33,160)	RS1/10S3R9J	R 547	(A,51,70)	RS1/16S104J						
R 474	(B,42,147)	CHIP TYPE RESISTOR									
R 475	(B,34,146)	RS1/10S3R9J									
R 476	(B,42,132)	CHIP TYPE RESISTOR	R 548	(B,49,46)	RS1/16S104J	R 549	(A,58,64)	RS1/16S104J			
R 477	(B,35,132)	RS1/10S3R9J	R 550	(B,55,89)	RS1/16S471J	R 551	(B,48,52)	RS1/16S101J			
R 478	(B,42,129)	CHIP TYPE RESISTOR	R 552	(B,70,109)	RS1/16S471J						
R 479	(B,43,139)	RS1/16S471J									
R 480	(B,35,129)	RS1/10S3R9J									
R 481	(B,44,153)	RS1/16S104J	R 553	(A,50,60)	RS1/16S101J	R 554	(B,58,92)	RS1/16S104J			D
R 484	(A,40,141)	RS1/16S102J	R 555	(B,74,110)	RS1/16S104J	R 556	(A,56,97)	RS1/16S392J			
R 485	(B,50,138)	RS1/16S223J	R 557	(A,55,90)	RS1/16S392J						
R 486	(A,41,149)	RS1/16S102J									
R 487	(B,49,151)	RS1/16S223J									
R 488	(B,42,156)	RS1/16S471J	R 558	(B,67,55)	RS1/16S103J	R 559	(B,37,93)	RS1/16S0R0J			
R 489	(B,42,161)	RS1/16S104J	R 560	(B,70,55)	RS1/16S153J	R 561	(B,69,53)	RS1/16S681J			
R 498	(A,120,84)	RS1/16S223J	R 562	(B,70,59)	RS1/16S103J						
R 499	(A,118,82)	RS1/16S223J									
R 501	(B,61,57)	RS1/10S75R0F									
R 502	(B,48,71)	RS1/10S75R0F	R 563	(B,29,94)	RS1/16S0R0J	R 564	(B,70,61)	RS1/16S153J			E
R 503	(B,48,76)	RS1/10S75R0F	R 565	(B,67,63)	RS1/16S681J	R 566	(B,74,65)	RS1/16S223J			
R 504	(B,51,92)	CHIP TYPE RESISTOR	R 568	(B,70,64)	RS1/16S123J						
R 505	(B,49,90)	RS1/10S3R9J									
R 506	(B,75,46)	RS1/16S0R0J									
R 507	(B,89,57)	RS1/16S472J	R 569	(B,76,65)	RS1/16S102J	R 571	(A,125,149)	RS1/10S75R0F			
R 508	(B,86,55)	RS1/16S473J	R 573	(B,51,64)	RS1/16S0R0J	R 574	(B,83,90)	RS1/16S0R0J			
R 509	(B,88,49)	RS1/16S273J	R 602	(B,62,172)	RS1/16S102J						
R 510	(B,87,52)	RS1/16S225J									
R 511	(B,84,49)	RS1/16S224J									
R 512	(B,84,51)	RS1/16S104J	R 603	(B,51,169)	RS1/16S0R0J	R 605	(B,83,170)	RS1/16S103J			
R 513	(B,81,61)	RS1/16S104J	R 606	(B,77,172)	RS1/16S103J	R 607	(B,55,166)	RS1/16S102J			F
R 514	(B,48,82)	RS1/10S75R0F	R 608	(B,31,175)	RS1/16S0R0J						
R 515	(B,80,78)	RS1/10S561J									
R 516	(B,79,75)	RS1/16S122J									

<u>Mark No.</u>	<u>Description</u>	<u>Part No.</u>	<u>Mark No.</u>	<u>Description</u>	<u>Part No.</u>
R 609 (B,27,183)		RS1/16S0R0J	C 142 (A,172,159)		CCSRCH102J50
R 616 (B,103,175)		RS1/16S0R0J	C 149 (A,197,103)		CCSRCH100D50
R 619 (A,106,170)		RS1/16S103J			
R 620 (A,126,163)		RS1/16S0R0J	C 150 (A,190,93)		CKSRYP105Z10
R 621 (A,109,162)		RS1/16S101J	C 152 (A,196,97)		CKSRYP105Z10
			C 156 (A,175,135)		CKSRYP104Z25
R 622 (A,109,160)		RS1/16S101J	C 157 (A,175,129)		CKSRYP104K16
R 623 (B,133,173)		RS1/16S102J	C 202 (A,194,65)		CKSRYP104Z25
R 624 (A,132,174)		RS1/16S332J			
R 625 (A,137,181)		RS1/16S332J	C 204 (A,190,69)		CEAT101M16
R 626 (B,144,176)		RS1/16S102J	C 205 (A,184,54)		CEAT220M25
			C 206 (B,192,74)		CCSRCH471J50
R 627 (A,130,173)		RS1/16S332J	C 208 (B,180,42)		CKSRYP104K16
R 628 (A,133,171)		RS1/16S332J	C 301 (B,171,42)		CKSRYP104Z25
R 630 (B,88,181)		RS1/16S331J			
R 631 (B,81,181)		RS1/16S472J	C 302 (B,176,42)		CKSRYP104Z25
R 632 (B,77,183)		RS1/16S220J	C 303 (A,169,47)		CEAT101M16
			C 305 (B,155,173)		CKSRYP104Z25
R 633 (B,79,181)		RS1/16S101J	C 306 (B,162,169)		CKSRYP104Z25
R 634 (B,77,179)		RS1/16S222J	C 307 (A,155,165)		CEAT101M16
R 635 (B,25,174)		RS1/16S0R0J			
R 636 (B,54,174)		RS1/16S0R0J	C 308 (A,150,174)		CEAT101M16
R 637 (B,58,174)		RS1/16S0R0J	C 309 (B,164,182)		CKSRYP104Z25
			C 310 (B,164,188)		CKSRYP104Z25
R 638 (B,66,175)		RS1/16S0R0J	C 311 (A,161,188)		CEAT221M16
R 701 (B,60,34)		RS1/16S224J	C 312 (A,149,182)		CEAT101M16
R 702 (B,30,29)		RS1/16S221J			
R 704 (B,30,32)		RS1/16S221J	C 314 (B,177,65)		CKSRYP104Z25
R 751 (B,46,37)		RS1/16S102J	C 315 (A,180,63)		CEAT101M16
			C 316 (A,180,70)		CEAT101M16
R 752 (B,48,41)		RS1/16S472J	C 318 (B,167,70)		CKSRYP104Z25
R 753 (B,58,43)		RS1/16S472J	C 319 (A,171,66)		CEAT101M16
R 754 (B,36,37)		RS1/16S151J			
R 755 (B,60,43)		RS1/16S472J	C 320 (A,172,76)		CEAT101M16
R 756 (B,40,37)		RS1/16S102J	C 322 (B,152,52)		CCSRCH101J50
			C 323 (B,166,45)	CERAMIC CAPACITOR	CKSQYF105Z50
			C 324 (B,163,71)		CKSRYP104Z25
			C 326 (A,158,49)		CEAT100M50
			C 328 (B,168,42)		CKSRYP104Z50
			C 329 (B,146,185)		CKSRYP104Z25
			C 401 (A,131,111)		CKSRYP105Z10
			C 402 (A,138,104)		CCSRCH101J50
			C 403 (A,134,105)		CCSRCH101J50
			C 404 (A,123,112)		CKSRYP105Z10
			C 405 (A,117,82)		CKSRYP103K50
			C 406 (A,117,108)		CKSRYP104K16
			C 407 (A,115,108)		CKSRYP105K10
			C 408 (A,112,108)		CKSRYP105K10
			C 409 (A,111,108)		CKSRYP105K10
			C 410 (A,109,108)		CKSRYP105K10
			C 411 (A,145,114)		CKSRYP105K10
			C 412 (A,144,119)		CKSRYP105K10
			C 413 (B,122,116)		CKSRYP104K16
			C 414 (A,137,113)		CKSRYP104Z25
			C 415 (A,139,113)		CKSRYP104Z25
			C 416 (A,147,110)		CKSRYP105K10
			C 417 (A,145,112)		CKSRYP105K10
			C 418 (A,143,121)		CKSRYP105Z10
			C 419 (A,142,124)		CKSRYP105K10
			C 420 (A,142,126)		CKSRYP105K10
			C 421 (A,143,127)		CKSRYP105K10
			C 422 (A,143,129)		CKSRYP105K10
			C 423 (A,143,131)		CKSRYP105K10
			C 424 (A,143,133)		CKSRYP105K10
			C 428 (A,125,137)		CKSRYP104K16
			C 431 (A,131,142)		CKSRYP104K16

CAPACITORS

C 104 (A,216,147)		CEAT220M25
C 105 (A,223,156)		CKSRYP104Z25
C 106 (A,226,169)		CKSRYP104Z25
C 107 (A,209,144)		CCSRCH331J50
C 109 (A,218,155)		CKSRYP104Z25
C 110 (A,219,164)		CKSRYP105K10
C 111 (B,214,159)		CCSRCH120J50
C 112 (B,210,159)		CCSRCH120J50
C 113 (A,201,145)		CKSRYP105Z10
C 114 (B,201,158)		CCSRCH150J50
C 115 (B,200,153)		CCSRCH150J50
C 119 (A,189,183)	ELECT. CAPACITOR	CEAT102M6R3
C 120 (B,165,179)		CKSRYP104Z25
C 121 (B,237,153)		CKSRYP105Z10
C 122 (B,173,181)		CKSRYP105Z10
C 123 (A,171,178)	ELECT. CAPACITOR	CEAT471M6R3
C 124 (A,189,152)		CKSRYP104Z25
C 125 (A,182,154)		CKSRYP104Z25
C 126 (A,187,132)		CKSRYP104Z25
C 127 (A,178,114)		CEAT101M16
C 131 (A,192,119)		CKSRYP104Z25
C 132 (A,193,116)		CKSRYP104Z25
C 133 (A,197,109)		CKSRYP104Z25
C 134 (A,203,106)		CKSRYP104Z25
C 135 (A,208,104)		CKSRYP104Z25
C 138 (A,221,119)		CEAT2R2M50
C 139 (A,216,126)		CKSRYP104Z25
C 140 (A,216,130)		CKSRYP104Z25
C 141 (A,172,157)		CKSRYP105Z10

5		6		7		8	
<u>Mark No.</u>	<u>Description</u>	<u>Part No.</u>	<u>Mark No.</u>	<u>Description</u>	<u>Part No.</u>		
C 432 (A,126,140)		CKSRYP105K10	C 519 (B,30,44)		CCSRCH471J50		
C 433 (A,110,144)		CKSRYP105K10	C 520 (B,36,56)		CCSRCH102J50		
C 434 (A,120,136)		CKSRYP104K16	C 528 (A,68,97)	ELECT. CAPACITOR	CEAT102M6R3		A
C 435 (A,102,110)		CKSRYP105K10	C 529 (A,73,128)	ELECT. CAPACITOR	CEAT471M6R3		
C 436 (A,102,112)		CKSRYP105K10	C 530 (A,73,113)	ELECT. CAPACITOR	CEAT471M6R3		
C 437 (A,102,114)		CKSRYP105K10	C 531 (A,73,120)	ELECT. CAPACITOR	CEAT471M6R3		
C 438 (A,108,117)		CKSRYP105Z10	C 532 (A,79,130)	ELECT. CAPACITOR	CEAT102M6R3		
C 439 (A,106,130)		CKSRYP104K16	C 541 (A,66,78)		CEAT4R7M50		
C 440 (A,117,137)		CKSRYP104K16	C 542 (A,66,84)		CEAT4R7M50		
C 441 (A,111,140)		CKSRYP105Z10	C 543 (A,66,90)		CEAT4R7M50		
C 442 (A,111,136)		CKSRYP104Z25	C 544 (A,73,107)		CEAT4R7M50		
C 443 (A,133,142)		CKSRYP105K10	C 545 (A,84,121)		CEAT101M16		
C 444 (A,124,144)		CKSRYP105K10	C 547 (A,63,51)		CEAT220M25		
C 445 (A,114,152)		CKSRYP105K10	C 550 (A,63,61)		CEAT220M25		B
C 446 (A,120,144)		CKSRYP105K10	C 551 (A,63,67)		CEAT220M25		
C 447 (A,130,150)		CKSRYP103K50	C 602 (B,27,173)		CKSRYP222K50		
C 450 (A,142,91)		CEANP4R7M50	C 603 (B,51,173)		CKSRYP222K50		
C 451 (A,137,91)		CEANP4R7M50	C 604 (B,60,174)		CCSRCH101J50		
C 452 (A,129,95)		CEAT101M10	C 605 (B,44,173)		CCSRCH100D50		
C 453 (A,135,96)		CEAT101M10	C 606 (B,48,173)		CCSRCH100D50		
C 454 (A,100,119)		CEAT101M10	C 609 (A,63,168)		CEAT101M10		
C 455 (A,153,118)		CEAT4R7M50	C 611 (A,56,169)		CEAT100M50		
C 456 (A,139,150)		CEAT1R0M50	C 613 (B,130,168)		CKSRYP104Z25		
C 457 (A,117,146)		CEAT100M50	C 614 (B,80,176)		CKSRYP104Z25		
C 458 (A,97,146)		CEAT101M10	C 615 (B,88,179)		CCSRCH101J50		C
C 460 (A,120,111)		CKSRYP105K10	C 616 (B,80,178)		CKSRYP103K50		
C 461 (A,125,97)		CKSRYP105K10	C 617 (A,114,183)		CKSRYP104Z25		
C 462 (A,126,92)		CKSRYP105Z10	C 618 (A,122,183)		CKSRYP104Z25		
C 464 (A,147,97)		CKSRYP104Z25	C 619 (A,125,181)		CKSRYP104Z25		
C 470 (A,113,84)		CKSRYP104K16	C 620 (A,109,180)		CKSRYP105Z10		
C 471 (A,151,107)		CEAT100M50	C 621 (B,88,183)		CCSRCH560J50		
C 472 (A,154,95)		CEAT100M50	C 622 (A,109,176)		CCSRCH560J50		
C 473 (A,131,84)		CEAT101M16	C 623 (B,97,180)		CCSRCH5R0C50		
C 474 (A,142,107)		CEAT100M50	C 624 (B,96,172)		CCSRCH5R0C50		
C 475 (A,148,93)		CEAT100M50	C 625 (B,122,171)		CKSRYP105Z10		
C 476 (B,43,116)		CKSRYP103K50	C 626 (B,139,182)		CKSRYP104Z25		D
C 477 (B,42,153)		CCSRCH152J50	C 627 (B,141,182)		CKSRYP104Z25		
C 483 (B,40,161)		CCSRCH152J50	C 628 (A,134,173)		CKSRYP103K50		
C 486 (A,53,112)	ELECT. CAPACITOR	CEAT102M6R3	C 629 (A,129,175)		CKSRYP392K50		
C 487 (A,54,155)	ELECT. CAPACITOR	CEAT102M6R3	C 630 (A,141,176)		CCSRCH561J50		
C 488 (A,53,141)	ELECT. CAPACITOR	CEAT471M6R3	C 631 (A,137,167)		CKSRYP103K50		
C 489 (A,53,129)	ELECT. CAPACITOR	CEAT471M6R3	C 632 (A,128,172)		CKSRYP392K50		
C 490 (A,53,121)	ELECT. CAPACITOR	CEAT102M6R3	C 633 (A,139,172)		CCSRCH561J50		
C 491 (A,53,135)		CEAT470M16	C 635 (A,111,166)		CCSRCH220J50		
C 492 (A,46,163)		CEAT221M6R3	C 636 (A,112,164)		CCSRCH220J50		
C 493 (A,53,148)		CEAT470M16	C 638 (A,114,188)		CEAT100M50		
C 497 (A,142,137)		CKSRYP104Z25	C 639 (A,120,188)		CEAT3R3M50		E
C 498 (A,144,151)		CKSRYP104Z25	C 640 (A,82,175)		CEAT101M10		
C 499 (A,139,144)		CKSRYP104Z25	C 641 (A,132,178)		CEAT100M50		
C 500 (A,136,141)		CKSRYP104Z25	C 642 (A,143,180)		CEAT101M10		
C 505 (B,43,60)		CCSRCH102J50	C 643 (A,127,168)		CEAT101M10		
C 506 (B,42,56)		CCSRCH471J50	C 702 (B,26,28)		CCSRCH681J50		
C 507 (B,35,50)		CCSRCH102J50	C 703 (B,24,30)		CKSRYP104Z25		
C 508 (B,42,50)		CCSRCH471J50	C 751 (B,49,37)		CKSRYP104Z25		
C 510 (B,75,50)		CKSRYP104Z25	C 752 (B,56,43)		CCSRCH101J50		
C 511 (B,84,53)		CCSRCH221J50	C 753 (B,46,41)		CCSRCH101J50		
C 515 (B,88,47)		CKSRYP104Z25	C 754 (B,27,40)		CCSRCH101J50		F
C 516 (B,32,47)		CCSRCH471J50					
C 517 (B,77,53)		CCSRCH221J50					
C 518 (B,28,44)		CCSRCH102J50					

Mark No. Description Part No.

Mark No. Description Part No.

B SERVICE FLKY ASSY

MISCELLANEOUS

A IC 101 (B,143,78) FL DRIVER IC PT6315
 Q 101 (B,31,57) DIGITAL TRANSISTOR DTC124EUA
 Q 103 (B,117,59) DIGITAL TRANSISTOR DTC124EUA
 Q 104 (B,204,73) TRANSISTOR 2SC5712
 Q 105 (B,200,68) TRANSISTOR 2SA1576A

R 121 (B,215,58) RS1/10S221J
 R 122 (B,215,56) RS1/16S122J
 R 123 (B,210,83) RS1/16S103J
 R 124 (B,204,61) RS1/16S102J
 R 125 (B,79,43) RS1/16S103J
 R 126 (B,81,43) RS1/16S103J
 R 127 (B,74,41) RS1/16S222J

Q 106 (B,210,61) TRANSISTOR 2SC4081
 Q 201 (B,99,15) DIGITAL TRANSISTOR DTC124EUA
 Q 202 (B,108,16) DIGITAL TRANSISTOR DTC124EUA
 Q 204 (B,91,16) DIGITAL TRANSISTOR DTC124EUA
 Q 205 (B,117,16) DIGITAL TRANSISTOR DTC124EUA

R 128 (B,109,42) RS1/16S222J
 R 129 (B,72,41) RS1/16S222J
 R 130 (B,111,40) RS1/16S222J
 R 131 (B,69,43) RS1/16S332J
 R 132 (B,113,40) RS1/16S332J

B Q 206 (B,83,18) DIGITAL TRANSISTOR DTC124EUA
 D 101 (A,22,61) LED(BLUE) SLR343BC4T
 D 103 (A,39,61) LED(ORANGE) SLR-343DC
 D 107 (B,221,41) DIODE RF101L2S
 D 108 (B,201,81) DIODE UDZS15(B)

R 133 (B,117,64) RS1/16S271J
 R 135 (B,201,52) RS1/16S562J
 R 137 (B,219,83) RS1/16S0R0J
 R 138 (B,191,83) RS1/16S0R0J
 R 144 (B,149,68) RS1/16S0R0J

D 109 (B,200,73) DIODE 1SS355
 D 110 (B,212,71) DIODE RF101L2S
 D 111 (B,209,79) DIODE UDZS2R4(B)
 D 112 (B,198,83) DIODE UDZS13(B)
 D 113 (A,120,62) LED(RED) SLR-343VC

R 148 (B,76,41) RS1/16S470J
 R 149 (B,87,44) RS1/16S470J
 R 150 (B,83,72) RS1/16S470J
 R 151 (B,61,49) RS1/16S0R0J
 R 204 (B,81,9) RS1/16S222J

C D 205 (A,88,22) LED(RED) SLR-343VC
 D 212 (A,75,22) LED(RED) SLR-343VC
 L 101 (A,197,68) AXIAL INDUCTOR LAU220JJA
 S 103 (A,91,45) SWITCH VSG1024
 S 104 (A,91,39) SWITCH VSG1024

R 205 (B,148,32) RS1/16S222J
 R 221 (B,79,24) RS1/16S271J
 R 222 (B,90,27) RS1/16S271J
 R 224 (B,109,26) RS1/16S271J
 R 226 (B,98,26) RS1/16S271J

S 105 (A,65,39) SWITCH VSG1024
 S 106 (A,116,39) SWITCH VSG1024
 S 107 (A,49,39) SWITCH VSG1024
 S 108 (A,116,45) SWITCH VSG1024
 S 109 (A,49,45) SWITCH VSG1024

R 228 (B,123,19) RS1/16S271J

CAPACITORS

S 110 (A,210,38) SWITCH VSG1024
 S 111 (A,65,45) SWITCH VSG1024
 S 112 (A,80,72) SWITCH VSG1024
 D S 201 (A,147,46) SWITCH VSG1024
 S 202 (A,77,10) SWITCH VSG1024

C 102 (B,39,54) CKSRYF104Z25
 C 103 (B,95,83) CKSRYB103K50
 C 104 (B,215,86) CKSRYB103K50
 C 106 (B,147,68) CKSRYF104Z25
 C 107 (B,155,82) CKSRYF104Z50

D CN101 CONNECTOR 9604S-17C
 CN301 (A,198,7) CONNECTOR HLEM11S-1
 07 FLKB AI VWG2602
 FL HOLDER (FE) FL HOLDER VNF1134
 103 REMOTE RECEIVER UNIT GP1UM28XK0VF

C 112 (B,132,80) CKSRYF104Z25
 C 113 (A,206,52) CEAL101M10
 C 115 (B,199,65) CKSRYF104Z25
 C 116 (A,199,61) CEJQ101M16
 C 117 (B,206,64) CKSRYB223K50

102 HOUSING ASS'Y(9P) VKP2393
 V 101 (A,95,89) FLUORESCENT TUBE VAW1091
 T 101 (A,220,51) TRANSFORMER VTT1171

C 118 (A,216,61) ELECTR. CAPACITOR CEAL100M50
 C 119 (B,97,35) CKSRYF104Z25
 C 121 (B,210,56) CKSRYB103K50
 C 123 (B,106,44) CKSRYF104Z25
 C 124 (B,104,45) CKSRYF104Z25

E RESISTORS

R 101 (B,35,57) RS1/16S182J
 R 104 (B,194,59) RS1/16S0R0J
 R 109 (B,48,55) RS1/16S151J
 R 110 (B,126,74) RS1/16S470J
 R 111 (B,128,74) RS1/16S470J
 R 112 (B,124,74) RS1/16S470J
 R 113 (B,133,72) RS1/16S823J
 R 114 (B,46,56) RS1/16S0R0J
 R 115 (B,85,72) RS1/16S103J
 R 117 (B,197,74) RS1/16S274J

C 127 (B,220,78) CKSRYF104Z25
 C 128 (A,221,65) CEAL101M10
 C 130 (B,83,68) CKSRYF104Z25
 C 132 (B,114,66) CKSRYF104Z25
 C 201 (B,148,29) CKSRYF104Z25

F R 118 (B,191,75) RS1/16S102J
 R 119 (B,208,73) RS1/16S273J
 R 120 (B,202,65) RS1/16S103J

C SERVICE FRJB ASSY

MISCELLANEOUS

301 (A,211,31) 4P MINIDIN SOCKET(S) AKP1238

5			6			7			8		
Mark No.	Description	Part No.	Mark No.	Description	Part No.	Mark No.	Description	Part No.	Mark No.	Description	Part No.
JA 302 (A,181,32)	JACK 3P PIN JACK	VKB1208	Q 3302	TRANSISTOR	2SC4081	Q 4581	TRANSISTOR	2SC4081	Q 5701	TRANSISTOR	2SC4081
KN 301 (A,231,17)	WRAPPING TERMINAL	VNF1084	Q 5801	CHIP TRANSISTOR	HN1C01FU	Q 5802	CHIP TR (PNP X 2)	UMB1N			
KN 302 (A,154,17)	WRAPPING TERMINAL	VNF1084				Q 5804	DIGITAL TRANSISTOR	DTC124EUA			
			Q 5805	TRANSISTOR	2SA1576A	Q 5808	MOS FET	2SK2034			
			Q 5809	TRANSISTOR	UMD2N	Q 5810	CHIP TRANSISTOR	UMF21N			
			D 101	LED	SML-310YT	D 3201	DIODE	DAN202U			
			D 3711	CHIP DIODE	RB501V-40	D 3712	CHIP DIODE	RB501V-40			
			D 4521	CHIP DIODE	RB501V-40	D 4552	CHIP DIODE	RB501V-40			
			D 4571	CHIP DIODE	RB501V-40	L 105	CHIP COIL	BTH1103			
			L 1001	EMI FILTER	DTL1106	L 1002	EMI FILTER	DTL1106			
			L 1003	EMI FILTER	DTL1106	L 1004	EMI FILTER	DTL1106			
			L 1005	INDUCTOR	LCTC150K2125	L 1021	EMI FILTER	DTL1106			
			L 1022	EMI FILTER	DTL1106	L 1023	EMI FILTER	DTL1106			
			L 1024	EMI FILTER	DTL1106	L 1024	EMI FILTER	DTL1106			
			L 1025	EMI FILTER	DTL1106	L 1801	CHIP COIL	LCYA390J2520			
			L 1811	INDUCTOR	LCYA150J2520	L 1821	EMI FILTER	DTL1106			
			L 1831	EMI FILTER	DTL1106	L 3301	CHIP COIL	LCYA180J2520			
			L 3302	INDUCTOR	LCYA100J2520	L 5101	INDUCTOR	CTF1305			
			L 5122	EMI FILTER	DTL1106	L 5201	COIL	ATH7015			
			L 5202	COIL	ATH7015	L 5601	EMI FILTER	DTL1106			
			L 5701	INDUCTOR	CTF1382	L 5801	COIL	ATH7022			
			L 5802	COIL	ATH7022	L 5802	COIL	ATH7022			
			L 5803	COIL	ATH7022	L 5804	COIL	ATH7022			
			L 5805	EMI FILTER	DTL1106	L 5805	EMI FILTER	DTL1106			
			JA 5701	JACK 1P PIN JACK	VKB1159	JA 5801	HDMI CONNECTOR	AKP1278			
			X 101	CERAMIC RESONATOR	DSS1157	X 1001	CRYSTAL RESONATOR	VSS1220			
			X 1002	CRYSTAL RESONATOR	VSS1172	X 5101	CRYSTAL	VSS1211			
			X 5201	CRYSTAL	VSS1218	X 5502	CRYSTAL	VSS1214			
			CN101	CONNECTOR 50P	DKN1404	CN103	CONNECTOR 14P	VKN2030			
			CN201	CONNECTOR 10P	VKN2029	CN501	FFC CONNECTOR	DKN1312			
			CN502	4P FFC CONNECTOR	DKN1288	CN601	5P FFC CONNECTOR	DKN1402			
			CN1401	14P CONNECTOR	VKN2030						

RESISTORS

R 303 (B,181,16)	RS1/16S0R0J
R 305 (B,178,15)	RS1/16S0R0J
R 306 (B,165,15)	RS1/16S0R0J

CAPACITORS

C 303 (B,181,20)	CCSRCH471J50
C 305 (B,162,18)	CCSRCH471J50

D SERVICE MAIN ASSY (DVR-LX60)

MISCELLANEOUS

IC 200	FLASH ROM IC	SST25V016BCS	D 4552	CHIP DIODE	RB501V-40
IC 201	SDRAM(64M)	K4S641632K-UC60	D 4571	CHIP DIODE	RB501V-40
IC 501	7CH DRIVER IC	BD7956FS	L 105	CHIP COIL	BTH1103
IC 1001	DVDR IC	MC-10050F1-107LU1A	L 1001	EMI FILTER	DTL1106
IC 1102	FLASH ROM	VYW2404	L 1002	EMI FILTER	DTL1106
IC 1201	DDR-SDRAM(512MBIT)	EDD5116AFTA-6B	L 1003	EMI FILTER	DTL1106
IC 1221	DDR-SDRAM(512MBIT)	EDD5116AFTA-6B	L 1004	EMI FILTER	DTL1106
IC 1301	IC	NJM12904V	L 1005	INDUCTOR	LCTC150K2125
IC 1302	IC	NJM12904V	L 1021	EMI FILTER	DTL1106
IC 3101	AD CONVERTER IC	AK5359ET	L 1022	EMI FILTER	DTL1106
IC 3201	IC	PCM1742KE	L 1023	EMI FILTER	DTL1106
IC 3202	OP-AMP IC	UPC4570G2	L 1024	EMI FILTER	DTL1106
IC 3701	IC	TC7WH34FU	L 1025	EMI FILTER	DTL1106
IC 3702	IC	TC7SH08FUS1	L 1801	CHIP COIL	LCYA390J2520
IC 3707	RESET IC	PST3813U	L 1811	INDUCTOR	LCYA150J2520
IC 4501	FUSE	CEK1285	L 1821	EMI FILTER	DTL1106
IC 4502	FUSE	CEK1285	L 1831	EMI FILTER	DTL1106
⚠ IC 4511	REGULATOR IC	S-1170B33UC-OTS	L 3301	CHIP COIL	LCYA180J2520
⚠ IC 4521	REGULATOR IC	S-1170B25UC-OTK	L 3302	INDUCTOR	LCYA100J2520
⚠ IC 4531	REGULATOR IC	MM1701WH	L 5101	INDUCTOR	CTF1305
⚠ IC 4541	REGULATOR IC (3.3V)	MM1563DF	L 5122	EMI FILTER	DTL1106
⚠ IC 4552	REGULATOR IC	S-1170B50UC-OUJ	L 5201	COIL	ATH7015
⚠ IC 4561	REGULATOR IC	S-1112B50MC-L7J	L 5202	COIL	ATH7015
⚠ IC 4562	REGULATOR IC	S-1112B33MC-L6S	L 5601	EMI FILTER	DTL1106
⚠ IC 4571	REGULATOR IC	S-1132B18-U5	L 5701	INDUCTOR	CTF1382
IC 4701	LOGIC IC	TC74VCX245FK	L 5801	COIL	ATH7022
IC 4702	IC	TC7SZ08FU	L 5802	COIL	ATH7022
IC 4703	LOGIC IC	TC74VHC125FK	L 5803	COIL	ATH7022
IC 5103	DV-PHY IC	UPD72852AGB-8EU	L 5804	COIL	ATH7022
IC 5202	IC	R5523N001B	L 5805	EMI FILTER	DTL1106
IC 5203	IC	TC7SH08FUS1	JA 5701	JACK 1P PIN JACK	VKB1159
⚠ IC 5204	REGULATOR IC	R1173H001B	JA 5801	HDMI CONNECTOR	AKP1278
IC 5602	SATA BRIDGE IC	88SA8040B1-TBC1	X 101	CERAMIC RESONATOR	DSS1157
IC 5701	IC	TC74VHC00FTS1	X 1001	CRYSTAL RESONATOR	VSS1220
IC 5801	HDMI TRANSMITER	SI19002CSU	X 1002	CRYSTAL RESONATOR	VSS1172
IC 5802	IC	TC7MB3257FK	X 5101	CRYSTAL	VSS1211
Q 102	TRANSISTOR	RT1N141U	X 5201	CRYSTAL	VSS1218
Q 1801	TRANSISTOR	2SA1576A	X 5502	CRYSTAL	VSS1214
Q 1811	TRANSISTOR	2SA1576A	CN101	CONNECTOR 50P	DKN1404
Q 2501	TRANSISTOR	2SA1576A	CN103	CONNECTOR 14P	VKN2030
Q 2502	TRANSISTOR	2SA1576A	CN201	CONNECTOR 10P	VKN2029
Q 2503	TRANSISTOR	2SA1576A	CN501	FFC CONNECTOR	DKN1312
Q 2504	TRANSISTOR	2SA1576A	CN502	4P FFC CONNECTOR	DKN1288
Q 2505	TRANSISTOR	2SA1576A	CN601	5P FFC CONNECTOR	DKN1402
Q 3301	TRANSISTOR	2SA1576A	CN1401	14P CONNECTOR	VKN2030

<u>Mark No.</u>	<u>Description</u>	<u>Part No.</u>	<u>Mark No.</u>	<u>Description</u>	<u>Part No.</u>
	CN1402 7P FFC CONNECTOR	RKN1048	R 222		RS1/16SS473J
	CN2301 40P CONNECTOR	VKN2065	R 223		RS1/16SS220J
	CN3801 FFC CONNECTOR 18P	VKN1811	R 230		RS1/16SS0R0J
A	CN4501 KR CONNECTOR	S13B-PH			
	CN4701 CONNECTOR	VKN2047	R 233		RS1/16SS0R0J
			R 234		RS1/16SS0R0J
	CN5101 CONNECTOR	VKN1932	R 236		RS1/16SS220J
	CN5201 CONNECTOR	VKN1936	R 237		RS1/16SS103J
	CN5604 SATA PLUG HEADER	VKN2063	R 238		RS1/16SS220J
	RADIATION SHEET	VEB1360			
	HEATSINK(AL)	VNH1079	R 239		RS1/16SS103J
			R 240		RS1/16SS220J
	SCREW	BBZ30P060FTC	R 241		RS1/16SS103J
			R 242		RS1/16SS220J
			R 243		RS1/16SS103J
<u>RESISTORS</u>					
B	R 104	RS1/16SS123J			
	R 105	RS1/16SS0R0J	R 244		RS1/16SS220J
	R 107	RS1/16SS473J	R 245		RS1/16SS103J
	R 108	RS1/16SS682J	R 248		RS1/16SS103J
	R 109	RS1/16SS622J	R 252		RS1/16SS103J
			R 253		RS1/16SS103J
	R 110	RS1/16SS102J			
	R 111	RS1/16SS474J	R 256		RS1/16SS103J
	R 112	RS1/16SS474J	R 271		RS1/10S0R0J
	R 114	RS1/16SS333J	R 273		RS1/10S0R0J
	R 115	RS1/16SS0R0J	R 274		RS1/10S0R0J
			R 281		RS1/16SS0R0J
	R 116	RS1/16SS332J			
C	R 117	RS1/16SS680J	R 301		RS1/16SS473J
	R 119	RS1/16SS0R0J	R 306		RS1/16SS222J
	R 124	RS1/16SS0R0J	R 307		RS1/16SS222J
	R 128	RS1/16SS0R0J	R 310		RS1/16SS102J
			R 311		RS1/16SS102J
	R 129	RS1/16SS0R0J			
	R 130	RS1/16SS221J	R 312		RS1/16SS102J
	R 131	RS1/16SS221J	R 313		RS1/16SS473J
	R 132	RS1/16SS221J	R 314		RS1/16SS102J
	R 133	RS1/16SS221J	R 317		RAB4CQ330J
			R 318		RAB4CQ330J
	R 134	RS1/16SS473J			
	R 135	RS1/16SS221J	R 319		RAB4CQ330J
D	R 136	RS1/16SS221J	R 320		RAB4CQ330J
	R 137	RS1/16SS221J	R 501		DCN1171
	R 138	RS1/16SS473J	R 502		DCN1172
			R 503		RS1/16SS102J
	R 139	RS1/16SS221J			
	R 165	RS1/16SS821J	R 504		RS1/16SS102J
	R 166	RS1/16SS821J	R 505		RS1/16SS123J
	R 167	RS1/16SS821J	R 506		RS1/16SS102J
	R 168	RS1/16SS0R0J	R 507		RS1/16SS102J
			R 510		RS1/10S1R8J
	R 170	RS1/16SS332J			
	R 171	RS1/16SS332J	R 511		RS1/10S1R8J
	R 172	RS1/16SS332J	R 515		RS1/16SS333J
E	R 174	RS1/16S4701F	R 516		RS1/16SS123J
	R 192	RS1/16S101J	R 601		RS1/16SS103J
			R 602		RS1/16SS103J
	R 193	RS1/16SS0R0J			
	R 201	RS1/16SS103J	R 603		RS1/16SS102J
	R 202	RS1/16SS330J	R 604		RS1/16SS102J
	R 203	RS1/16SS330J	R 1001		RS1/16SS103J
	R 204	RAB4CQ330J	R 1003	CHIP RESISTOR	RS1/16S6800F
			R 1004		RS1/16S4700F
	R 205	RAB4CQ330J			
	R 206	RAB4CQ330J	R 1005		RS1/16SS153J
	R 210	RS1/16SS330J	R 1006		RS1/16SS153J
	R 211	RS1/16SS0R0J	R 1013		RS1/16SS103J
F	R 219 RESISTOR ARRAY	RAB4CQ472J	R 1016		RS1/16SS103J
			R 1017		RS1/16SS0R0J
	R 220 RESISTOR ARRAY	RAB4CQ472J			
	R 221	RS1/16SS473J	R 1018		RS1/16SS0R0J
			R 1019		RS1/16SS0R0J

5		6		7		8	
<u>Mark No.</u>	<u>Description</u>	<u>Part No.</u>	<u>Mark No.</u>	<u>Description</u>	<u>Part No.</u>		
R 1021		RS1/16SS103J	R 1268	RESISTOR ARRAY	RAB4CQ0R0J		
R 1027		RS1/16SS103J	R 1269	RESISTOR ARRAY	RAB4CQ0R0J		
R 1028		RS1/16SS103J	R 1270		RS1/16SS0R0J		
R 1029		RS1/16SS820J	R 1271		RS1/16SS330J		A
R 1030		RS1/16SS101J	R 1272		RS1/16SS330J		
R 1031		RS1/16SS221J	R 1273	RESISTOR ARRAY	RAB4CQ220J		
R 1032	RESISTOR ARRAY	RAB4CQ103J	R 1274	RESISTOR ARRAY	RAB4CQ220J		
R 1033	RESISTOR ARRAY	RAB4CQ103J	R 1275		RS1/16SS220J		
R 1034	RESISTOR ARRAY	RAB4CQ103J	R 1276		RS1/16SS220J		
R 1035	RESISTOR ARRAY	RAB4CQ103J	R 1277		RS1/16SS0R0J		
R 1036		RS1/16S43R0D	R 1278		RS1/16SS0R0J		
R 1037	CHIP RESISTOR	RS1/16S1000F	R 1279		RS1/16SS391J		
R 1039		RS1/16S43R0D	R 1281	RESISTOR ARRAY	RAB4CQ470J		
R 1040	CHIP RESISTOR	RS1/16S1000F	R 1282	RESISTOR ARRAY	RAB4CQ470J		B
R 1066		RS1/16SS473J	R 1283	RESISTOR ARRAY	RAB4CQ470J		
R 1067		RS1/16SS473J	R 1284		RS1/16SS470J		
R 1068		RS1/16SS473J	R 1285		RS1/16SS470J		
R 1069		RS1/16SS473J	R 1286		RS1/16SS470J		
R 1071		RS1/16SS103J	R 1287	RESISTOR ARRAY	RAB4CQ470J		
R 1103		RS1/16SS0R0J	R 1288		RS1/16SS220J		
R 1107		RS1/16SS0R0J	R 1289		RS1/16SS220J		
R 1110		RS1/16SS0R0J	R 1301		RS1/16S4700F		
R 1111		RS1/16SS104J	R 1302		RS1/16S1001F		
R 1132		RS1/16SS470J	R 1303		RS1/16S1001F		C
R 1153		RS1/16SS472J	R 1312		RS1/16S1001F		
R 1161		RS1/16SS472J	R 1313		RS1/16S1001F		
R 1163		RS1/16SS472J	R 1314		RS1/16S0R0J		
R 1164		RS1/16SS472J	R 1401		RS1/16SS220J		
R 1181		RS1/16SS103J	R 1402		RS1/16SS220J		
R 1182		RS1/16SS103J	R 1403		RS1/16SS220J		
R 1191		RS1/16SS472J	R 1404		RS1/16SS220J		
R 1195		RS1/16SS472J	R 1405		RS1/16SS220J		
R 1199		RS1/16SS103J	R 1406		RS1/16SS220J		
R 1205		RS1/16SS103J	R 1407		RS1/16SS220J		
R 1219		RS1/16SS0R0J	R 1411	RESISTOR ARRAY	RAB4CQ103J		D
R 1240		RS1/16SS220J	R 1412		RS1/16SS103J		
R 1241	RESISTOR ARRAY	RAB4CQ0R0J	R 1413		RS1/16SS473J		
R 1242	RESISTOR ARRAY	RAB4CQ0R0J	R 1414		RS1/16SS220J		
R 1243		RS1/16SS0R0J	R 1415		RS1/16SS220J		
R 1244		RS1/16SS330J	R 1416		RS1/16SS220J		
R 1245	RESISTOR ARRAY	RAB4CQ220J	R 1421		RS1/16SS103J		
R 1246	RESISTOR ARRAY	RAB4CQ220J	R 1422		RS1/16SS103J		
R 1247		RS1/16SS220J	R 1802		RS1/16SS221J		
R 1248	RESISTOR ARRAY	RAB4CQ0R0J	R 1803		RS1/16SS331J		
R 1249	RESISTOR ARRAY	RAB4CQ0R0J	R 1804		RS1/16SS330J		
R 1250		RS1/16SS0R0J	R 1812		RS1/16SS221J		
R 1251		RS1/16SS330J	R 1813		RS1/16SS331J		E
R 1252		RS1/16SS330J	R 1814		RS1/16SS330J		
R 1255	RESISTOR ARRAY	RAB4CQ220J	R 2301		RS1/16SS332J		
R 1256	RESISTOR ARRAY	RAB4CQ220J	R 2302		RS1/16SS0R0J		
R 1257		RS1/16SS220J	R 2304		RS1/16SS0R0J		
R 1258		RS1/16SS220J	R 2316		RS1/16SS103J		
R 1260		RS1/16SS220J	R 2501		RS1/16SS681J		
R 1261	RESISTOR ARRAY	RAB4CQ0R0J	R 2502		RS1/16S1500F		
R 1262	RESISTOR ARRAY	RAB4CQ0R0J	R 2504		RS1/16SS681J		
R 1263		RS1/16SS0R0J	R 2505		RS1/16S1500F		
R 1264		RS1/16SS330J	R 2506		RS1/16S0R0J		
R 1265	RESISTOR ARRAY	RAB4CQ220J	R 2507		RS1/16SS681J		F
R 1266	RESISTOR ARRAY	RAB4CQ220J	R 2508		RS1/16S1500F		
R 1267		RS1/16SS220J	R 2510		RS1/16SS681J		

<u>Mark No.</u>	<u>Description</u>	<u>Part No.</u>	<u>Mark No.</u>	<u>Description</u>	<u>Part No.</u>
R 2511		RS1/16S1500F	R 3309		RS1/16SS681J
R 2513		RS1/16SS681J	R 3310		RS1/16SS103J
R 2514		RS1/16S1500F	R 3315		RS1/16SS681J
A					
R 3002		RS1/16SS0R0J	R 3320		RS1/16SS681J
R 3003		RS1/16SS0R0J	R 3327		RS1/16SS681J
R 3004		RS1/16SS0R0J	R 3336		RS1/16SS0R0J
R 3005	RESISTOR ARRAY	RAB4CQ103J	R 3337		RS1/16SS103J
R 3006		RS1/16SS0R0J	R 3341		RS1/16SS0R0J
R 3007		RS1/16SS0R0J	R 3342		RS1/16SS103J
R 3008		RS1/16SS0R0J	R 3703		RS1/16SS101J
R 3009		RS1/16SS0R0J	R 3704		RS1/16SS101J
R 3010		RS1/16SS0R0J	R 3705		RS1/16SS101J
R 3011		RS1/16SS0R0J	R 3708		RS1/16SS103J
B					
R 3012		RS1/16SS0R0J	R 3715		RS1/16SS0R0J
R 3101		RS1/16SS0R0J	R 3716		RS1/16SS330J
R 3102		RS1/16SS0R0J	R 3720		RS1/16SS0R0J
R 3103		RS1/16SS0R0J	R 3738		RS1/16SS103J
R 3104		RS1/16SS0R0J	R 3808		RS1/16SS101J
R 3105		RS1/16SS105J	R 3810		RAB4CQ330J
R 3106		RS1/16SS103J	R 3811		RAB4CQ330J
R 3107		RS1/16SS470J	R 3812		RAB4CQ330J
R 3108		RS1/16SS470J	R 3813		RAB4CQ330J
R 3109		RS1/16SS470J	R 3814		RS1/16SS220J
R 3111		RS1/16SS0R0J	R 3816		RS1/16SS820J
R 3113		RS1/16SS103J	R 3817		RS1/16SS820J
R 3201		RS1/16SS470J	R 3818		RS1/16SS220J
R 3202		RS1/16SS470J	R 3820		RS1/16SS820J
R 3203		RS1/16SS470J	R 3821		RS1/16SS220J
R 3204		RS1/16SS0R0J	R 3823		RS1/16SS820J
R 3206		RS1/16SS470J	R 3824	RESISTOR ARRAY	RAB4CQ820J
R 3207		RS1/16SS470J	R 3828	RESISTOR ARRAY	RAB4CQ223J
R 3208		RS1/16SS470J	R 3829	RESISTOR ARRAY	RAB4CQ223J
R 3209		RS1/16SS104J	R 3830	RESISTOR ARRAY	RAB4CQ223J
R 3210		RN1/16SE1201D	R 3831	RESISTOR ARRAY	RAB4CQ223J
R 3211		RN1/16SE1002D	R 3832	RESISTOR ARRAY	RAB4CQ223J
R 3213		RS1/16SS681J	R 3833	RESISTOR ARRAY	RAB4CQ223J
R 3214		RS1/16SS682J	R 3835		RS1/16SS330J
R 3215		RS1/16SS223J	R 3837		RAB4CQ330J
R 3216		RN1/16SE1201D	R 3838		RAB4CQ330J
R 3217		RN1/16SE1002D	R 3839		RAB4CQ330J
R 3218		RN1/16SE2202D	R 3840		RAB4CQ330J
R 3219		RS1/16SS682J	R 3841		RS1/16SS820J
R 3220		RS1/16SS101J	R 3842		RS1/16SS562J
R 3221		RS1/16SS101J	R 3843		RS1/16SS220J
R 3222		RS1/16SS682J	R 3844		RS1/16SS220J
R 3223		RN1/16SE2202D	R 3845		RS1/16SS820J
R 3224		RS1/16SS101J	R 3846		RS1/16SS102J
R 3227		RS1/16SS101J	R 3847		RS1/16SS220J
R 3228		RS1/16SS103J	R 3848		RS1/16SS820J
R 3229		RS1/16SS103J	R 3849		RS1/16SS103J
R 3230		RS1/10S0R0J	R 3850		RS1/16SS330J
R 3232		RS1/16SS0R0J	R 3851		RAB4CQ330J
R 3233		RS1/16SS0R0J	R 3857		RS1/16SS0R0J
R 3234		RS1/16SS0R0J	R 3862		RS1/16SS0R0J
R 3301		RS1/16SS470J	R 3871		RS1/16SS223J
R 3302		RS1/16SS0R0J	R 4501		RS1/10S0R0J
R 3305		RS1/16SS331J	R 4511		RS1/16SS0R0J
R 3306		RS1/16S4700F	R 4521		RS1/16SS682J
R 3307	CHIP RESISTOR	RS1/16SS1801F	R 4526		RS1/16SS153J
R 3308		RS1/16SS100J	R 4531		RS1/16SS0R0J

5		6		7		8	
<u>Mark No.</u>	<u>Description</u>	<u>Part No.</u>	<u>Mark No.</u>	<u>Description</u>	<u>Part No.</u>		
R 4541		RS1/16SS0R0J	R 5125		RS1/16SS102J		
R 4551		RS1/10S0R0J	R 5127		RS1/16SS103J		
R 4552		RS1/10S0R0J	R 5129		RS1/16SS820J		
R 4553		RS1/10S0R0J	R 5130		RS1/16SS0R0J		A
R 4554		RS1/10S0R0J	R 5131		RN1/16SE5101D		
R 4556		RS1/10S0R0J	R 5132		RS1/16SS0R0J		
R 4558		RS1/16SS223J	R 5133		RS1/16SS0R0J		
R 4559		RS1/16SS0R0J	R 5134		RS1/16SS0R0J		
R 4573		RS1/16SS0R0J	R 5135		RS1/16SS0R0J		
R 4574		RS1/16S0R0J	R 5140		RS1/16SS103J		
R 4575		RS1/16S0R0J	R 5141		RS1/16SS0R0J		
R 4581		RS1/16SS101J	R 5201		RS1/16SS0R0J		
R 4701	RESISTOR ARRAY	RAB4CQ101J	R 5202		RS1/16SS0R0J		
R 4702	RESISTOR ARRAY	RAB4CQ101J	R 5203		RS1/16S3301F		B
R 4703		RS1/16SS101J	R 5204		RS1/16S8200F		
R 4704		RS1/16SS0R0J	R 5205		RS1/16SS680J		
R 4705		RS1/16SS0R0J	R 5207		RS1/16SS0R0J		
R 4706		RS1/16SS0R0J	R 5212		RS1/16SS0R0J		
R 4707		RS1/16SS103J	R 5213		RS1/16SS0R0J		
R 4708	RESISTOR ARRAY	RAB4CQ103J	R 5214		RS1/16SS473J		
R 4709	RESISTOR ARRAY	RAB4CQ103J	R 5215		RS1/16SS473J		
R 4710		RS1/16SS103J	R 5216		RS1/16SS0R0J		
R 4711		RS1/16SS103J	R 5217		RS1/16SS0R0J		
R 4712		RS1/16SS103J	R 5220		RS1/16S1501F		
R 4713		RS1/16SS103J	R 5221		RS1/16SS473J		C
R 4714		RS1/16SS0R0J	R 5222		RS1/16SS100J		
R 4721	RESISTOR ARRAY	RAB4CQ101J	R 5445		RS1/10S0R0J		
R 4722	RESISTOR ARRAY	RAB4CQ101J	R 5606		RS1/16SS820J		
R 4723		RS1/16SS470J	R 5607		RS1/16SS820J		
R 4724		RS1/16SS220J	R 5608		RS1/16SS103J		
R 4725		RS1/16SS220J	R 5609		RS1/16SS103J		
R 4726		RS1/16SS220J	R 5610		RS1/16SS102J		
R 4727		RS1/16SS103J	R 5612		RS1/16SS103J		
R 4728		RS1/16SS103J	R 5613		RS1/16SS102J		
R 4729		RS1/16SS0R0J	R 5614		RS1/16SS102J		
R 4731		RS1/16SS472J	R 5615		RS1/16SS102J		D
R 4732		RS1/16SS472J	R 5616		RS1/16SS103J		
R 5101	RESISTOR ARRAY	RAB4CQ104J	R 5618		RS1/16SS103J		
R 5102	RESISTOR ARRAY	RAB4CQ104J	R 5619		RS1/16SS102J		
R 5103		RS1/16SS104J	R 5622		RS1/16SS820J		
R 5104		RS1/16SS104J	R 5623		RS1/16SS820J		
R 5105	RESISTOR ARRAY	RAB4CQ680J	R 5624		RS1/16SS820J		
R 5106	RESISTOR ARRAY	RAB4CQ680J	R 5626		RS1/16SS220J		
R 5107		RS1/16SS680J	R 5627		RS1/16SS820J		
R 5108		RS1/16SS680J	R 5628		RS1/16SS220J		
R 5109		RS1/16SS470J	R 5629		RS1/16SS820J		
R 5110		RS1/16SS103J	R 5630		RS1/16SS820J		E
R 5111		RS1/16SS102J	R 5631		RS1/16SS220J		
R 5113		RS1/16SS103J	R 5632		RAB4CQ330J		
R 5114		RS1/16SS103J	R 5638		RAB4CQ330J		
R 5115		RS1/16SS103J	R 5642		RAB4CQ330J		
R 5116		RS1/16SS103J	R 5646		RAB4CQ330J		
R 5117		RS1/16SS104J	R 5650		RS1/16SS820J		
R 5118		RN1/16SE9101D	R 5651		RS1/16S1202F		
R 5119	CHIP RESISTOR	RS1/16S56R0D	R 5652		RS1/16SS101J		
R 5120	CHIP RESISTOR	RS1/16S56R0D	R 5657		RS1/16SS102J		
R 5121	CHIP RESISTOR	RS1/16S56R0D	R 5658		RS1/16SS102J		
R 5122	CHIP RESISTOR	RS1/16S56R0D	R 5659		RS1/16SS102J		F
R 5123		RS1/16SS103J	R 5661		RS1/16SS102J		
R 5124		RS1/16SS103J	R 5664		RS1/16S0R0J		

Mark No. Description**Part No.****Mark No. Description****Part No.**

R 5672 RS1/16S0R0J
 R 5688 RS1/16SS105J
 R 5689 RS1/16SS152J

R 5867 RS1/16SS561J
 R 5868 RS1/16SS222J
 R 5869 RS1/16SS472J

A

R 5690 RS1/16SS0R0J
 R 5692 RS1/16SS0R0J
 R 5693 RS1/16SS0R0J
 R 5701 RS1/16SS471J
 R 5702 RS1/16SS471J

R 5870 RS1/16SS273J
 R 6001 RS1/16SS0R0J

CAPACITORS

R 5703 RS1/16SS681J
 R 5704 RS1/16SS151J
 R 5705 RS1/16S0R0J
 R 5706 CHIP RESISTOR RS1/16S75R0F
 R 5707 RS1/16SS104J

C 100 CKSSYB102K50
 C 101 CKSSYB102K50
 C 103 CHIP ELECT.CAPACITOR CEVW221M4
 C 104 CAPACITOR(CERAMIC) VCG1057
 C 105 CKSSYB102K50

B

R 5803 RS1/16S0R0J
 R 5804 RS1/16SS473J
 R 5805 RS1/16SS472J
 R 5806 RS1/16SS102J
 R 5807 RS1/16SS562J

C 106 CKSSYF104Z16
 C 107 CKSSYB681K50
 C 113 CKSSYB472K25
 C 114 CKSSYB472K25
 C 115 CKSSYB103K16

R 5808 RS1/16SS472J
 R 5809 RS1/16SS272J
 R 5812 RS1/16SS472J
 R 5813 RS1/16SS272J
 R 5814 RS1/16SS472J

C 116 CKSSYB104K10
 C 117 CKSSYB102K50
 C 120 CKSSYB104K10
 C 121 CKSSYB222K50
 C 122 CKSSYB222K50

C

R 5815 RS1/16SS272J
 R 5817 RS1/16SS472J
 R 5818 RS1/16SS472J
 R 5821 RS1/16SS472J
 R 5822 RS1/16SS472J

C 124 CKSSYB104K10
 C 125 CAPACITOR(CERAMIC) VCG1058
 C 127 CKSSYB473K10
 C 128 CKSSYB104K10
 C 129 CAPACITOR(CERAMIC) VCG1058

R 5824 RS1/10S0R0J
 R 5825 RESISTOR ARRAY RAB4CQ220J
 R 5826 RESISTOR ARRAY RAB4CQ220J
 R 5827 RESISTOR ARRAY RAB4CQ220J
 R 5828 RESISTOR ARRAY RAB4CQ220J

C 130 CKSQYB475K6R3
 C 131 CKSSYB683K10
 C 133 CKSSYB104K10
 C 134 CKSSYB104K10
 C 135 CKSSYB103K16

R 5829 RS1/16SS560J
 R 5831 RS1/16SS0R0J
 R 5832 RS1/16S0R0J
 R 5833 RS1/16SS220J
 R 5834 RS1/16SS220J

C 136 CKSSYB104K10
 C 137 CKSSYB682K25
 C 140 ELECT. CAPACITOR DCH1199
 C 141 ELECT. CAPACITOR DCH1199
 C 142 DCH1201

D

R 5836 RS1/16SS103J
 R 5837 RS1/16SS0R0J
 R 5838 RS1/16SS330J
 R 5839 RS1/16SS471J
 R 5842 RS1/16SS331J

C 143 DCH1201
 C 144 CKSSYB103K16
 C 145 CKSSYB103K16
 C 146 DCH1201
 C 147 ELECT. CAPACITOR DCH1198

R 5843 RS1/16SS331J
 R 5844 RS1/16SS331J
 R 5845 RS1/16SS331J
 R 5846 RS1/16SS472J
 R 5848 RS1/16SS472J

C 148 ELECT. CAPACITOR DCH1198
 C 149 CKSSYB103K16
 C 152 CKSSYB102K50
 C 153 CEVW100M16
 C 154 CAPACITOR(CERAMIC) VCG1057

E

R 5852 RS1/16SS103J
 R 5853 RS1/16SS103J
 R 5854 RS1/16SS103J
 R 5855 RESISTOR ARRAY RAB4CQ100J
 R 5856 RS1/16SS103J

C 155 ELECT. CAPACITOR DCH1199
 C 156 CKSSYB182K50
 C 157 CKSSYB103K16
 C 158 CKSSYB103K16
 C 159 CKSSYF104Z16

R 5857 RS1/16SS103J
 R 5859 RS1/16SS103J
 R 5861 RS1/16SS103J
 R 5862 RS1/16SS472J
 R 5863 RS1/16SS681J

C 162 CAPACITOR(CERAMIC) VCG1057
 C 163 CHIP ELECT.CAPACITOR CEVW221M4
 C 164 CKSSYB102K50
 C 165 CCSSCH220J50
 C 166 CCSSCH220J50

F

R 5864 RS1/16SS102J
 R 5865 RS1/16SS0R0J

C 167 CKSSYF104Z16
 C 169 CKSSYB104K10
 C 170 CCSSCH470J50

5		6		7		8	
<u>Mark No.</u>	<u>Description</u>	<u>Part No.</u>	<u>Mark No.</u>	<u>Description</u>	<u>Part No.</u>		
C 171		CKSSYB104K10	C 1017		CKSSYB104K10		
C 172		CCSSCH470J50	C 1018		CKSSYB104K10		
C 173		CCSSCH470J50	C 1019		CKSSYB104K10		A
C 174		CCSSCH470J50	C 1020		CEVW100M16		
C 176		CCSSCH220J50	C 1021		DCH1201		
C 177		CCSSCH220J50	C 1022	CAPACITOR(CERAMIC)	VCG1057		
C 180		DCH1201	C 1023		CKSSYB102K50		
C 181		CKSQYB475K6R3	C 1024	CHIP ELECT.CAPACITOR	CEVW101M4		
C 182		DCH1201	C 1025	CAPACITOR(CERAMIC)	VCG1057		
C 187		CKSSYB103K16	C 1026		CKSSYB102K50		
C 188		CKSSYB103K16	C 1027		CKSSYB104K10		
C 189		CKSSYB102K50	C 1028		CKSSYB104K10		
C 194		CKSQYB475K6R3	C 1029		CKSSYB104K10		
C 197		CKSSYB104K10	C 1030		CKSSYB104K10		B
C 199	CAPACITOR(CERAMIC)	VCG1057	C 1031		CKSSYB104K10		
C 201		CKSSYB104K10	C 1032		CKSSYB104K10		
C 202	CAPACITOR(CERAMIC)	VCG1057	C 1033		CKSSYB104K10		
C 280	CAPACITOR(CERAMIC)	VCG1058	C 1034		CKSSYB104K10		
C 281	CAPACITOR(CERAMIC)	VCG1058	C 1035		CKSSYB104K10		
C 282	CAPACITOR(CERAMIC)	VCG1058	C 1036	CHIP ELECT.CAPACITOR	CEVW101M4		
C 283	CAPACITOR(CERAMIC)	VCG1058	C 1037	CAPACITOR(CERAMIC)	VCG1057		
C 284	CAPACITOR(CERAMIC)	VCG1058	C 1038		CKSSYB102K50		
C 285	CAPACITOR(CERAMIC)	VCG1058	C 1039	CHIP ELECT.CAPACITOR	CEVW101M4		
C 286		DCH1201	C 1040	CAPACITOR(CERAMIC)	VCG1057		
C 287	CAPACITOR(CERAMIC)	VCG1058	C 1041		CKSSYB102K50		C
C 288		CKSSYF104Z16	C 1042		CCSSCJ3R0C50		
C 289		CKSSYB102K50	C 1043		CCSSCJ3R0C50		
C 290		CKSSYF104Z16	C 1044		CCSSCH5R0C50		
C 291		CKSSYB102K50	C 1045		CCSSCH5R0C50		
C 501		CKSSYF104Z16	C 1047		CKSSYB104K10		
C 502	CHIP CERAMIC C.	DCH1263	C 1048	CAPACITOR(CERAMIC)	VCG1057		
C 503		CKSRYB471K50	C 1049		CKSSYB102K50		
C 504		CKSSYB104K10	C 1050	CHIP ELECT.CAPACITOR	CEVW101M4		
C 505		CKSRYB104K25	C 1051		DCH1201		
C 508		CKSSYB102K50	C 1052	CAPACITOR(CERAMIC)	VCG1057		
C 509		CCSSCH330J50	C 1053		CKSSYB102K50		D
C 510		CCSSCH680J50	C 1056	CAPACITOR(CERAMIC)	VCG1057		
C 511		CKSQYB105K16	C 1057		CKSSYF104Z16		
C 512		CKSRYF104Z16	C 1058		CKSSYB103K16		
C 513		CKSRYF104Z16	C 1059	CAPACITOR(CERAMIC)	VCG1057		
C 514		CKSRYB104K25	C 1060		CKSSYF104Z16		
C 515		CKSRYB104K25	C 1061		CKSSYB102K50		
C 516		CKSSYB104K10	C 1062	CAPACITOR(CERAMIC)	VCG1057		
C 532		CKSSYB104K10	C 1063		CKSSYF104Z16		
C 1001		CKSSYB104K10	C 1064		CKSSYB102K50		
C 1002		CKSSYB104K10	C 1065		CKSSYB102K50		
C 1003	CHIP ELECT.CAPACITOR	CEVW101M4	C 1066	CAPACITOR(CERAMIC)	VCG1057		E
C 1004	CAPACITOR(CERAMIC)	VCG1057	C 1067		CKSSYF104Z16		
C 1005		CKSSYB102K50	C 1068		CKSSYB102K50		
C 1006	CAPACITOR(CERAMIC)	VCG1057	C 1101		CKSSYB102K50		
C 1007	CHIP ELECT.CAPACITOR	CEVW221M4	C 1104	CAPACITOR(CERAMIC)	VCG1057		
C 1008	CAPACITOR(CERAMIC)	VCG1057	C 1105		CKSSYF104Z16		
C 1009	CHIP ELECT.CAPACITOR	CEVW221M4	C 1113	CAPACITOR(CERAMIC)	VCG1057		
C 1010	CAPACITOR(CERAMIC)	VCG1057	C 1202	CAPACITOR(CERAMIC)	VCG1057		
C 1011		CKSSYB102K50	C 1203		CKSSYF104Z16		
C 1012	CHIP ELECT.CAPACITOR	CEVW101M4	C 1204	CAPACITOR(CERAMIC)	VCG1057		
C 1013	CAPACITOR(CERAMIC)	VCG1057	C 1205		CKSSYB103K16		F
C 1014		CKSSYB102K50	C 1206		CKSSYB103K16		
C 1015		CKSSYB104K10	C 1207		CKSSYB102K50		
C 1016		CKSSYB104K10	C 1208	CAPACITOR(CERAMIC)	VCG1057		

	<u>Mark No.</u>	<u>Description</u>	<u>Part No.</u>	<u>Mark No.</u>	<u>Description</u>	<u>Part No.</u>
	C 1209		CKSSYB102K50	C 3202		CKSSYF104Z16
	C 1210		CKSSYB102K50	C 3203		CKSSYB102K50
A	C 1211		CKSSYF104Z16	C 3204		CKSSYB331K50
	C 1212		CKSSYF104Z16	C 3206		CKSSYF104Z16
	C 1213		CKSSYF104Z16	C 3207		CEVW470M6R3
	C 1214		CKSSYF104Z16	C 3211		CEVW101M16
	C 1215	CHIP ELECT.CAPACITOR	CEVW101M4	C 3212		CKSSYF104Z16
	C 1216	CAPACITOR(CERAMIC)	VCG1057	C 3213		CKSSYB561K50
	C 1217	CAPACITOR(CERAMIC)	VCG1057	C 3214		CKSSYB561K50
	C 1218	CAPACITOR(CERAMIC)	VCG1057	C 3215		CCSSCH820J50
	C 1219	CAPACITOR(CERAMIC)	VCG1057	C 3216		CCSSCH820J50
	C 1220	CAPACITOR(CERAMIC)	VCG1057	C 3217		CKSSYF104Z16
	C 1221	CAPACITOR(CERAMIC)	VCG1057	C 3218		CEVW101M16
B	C 1222		CKSSYF104Z16	C 3219	CHIP ELECT.CAPACITOR	CEVW221M4
	C 1223	CAPACITOR(CERAMIC)	VCG1057	C 3220	CAPACITOR(CERAMIC)	VCG1057
	C 1224		CKSSYB103K16	C 3301		CCSRCH7R0D50
	C 1225		CKSSYB103K16	C 3302		CCSRCH7R0D50
	C 1226		CKSSYB102K50	C 3303		CCSSCH150J50
	C 1227	CAPACITOR(CERAMIC)	VCG1057	C 3304		CCSSCH820J50
	C 1228		CKSSYB102K50	C 3305		CCSSCH220J50
	C 1229		CKSSYB102K50	C 3307		DCH1201
	C 1230		CKSSYF104Z16	C 3313		CKSQYB103K50
	C 1231		DCH1201	C 3319		CKSQYB103K50
	C 1235		DCH1201	C 3325		CKSQYB103K50
C	C 1236	CHIP ELECT.CAPACITOR	CEVW101M4	C 3332	CAPACITOR(CERAMIC)	VCG1057
	C 1291		CKSSYF104Z16	C 3342	CAPACITOR(CERAMIC)	VCG1057
	C 1301		CKSQYB225K10	C 3701		CKSSYB103K16
	C 1302		CKSSYF104Z16	C 3703	CAPACITOR(CERAMIC)	VCG1057
	C 1303		CKSSYF104Z16	C 3704		DCH1201
	C 1304		CEVW470M6R3	C 3705		CKSSYB102K50
	C 1312		CKSSYF104Z16	C 3706		CKSSYB102K50
	C 1313		CKSSYF104Z16	C 3707	CAPACITOR(CERAMIC)	VCG1057
	C 1315		CKSQYB225K10	C 3738	CAPACITOR(CERAMIC)	VCG1057
	C 1316		DCH1201	C 3801	CAPACITOR(CERAMIC)	VCG1057
	C 1401		CKSSYB103K16	C 3802	CAPACITOR(CERAMIC)	VCG1057
D	C 1421	CAPACITOR(CERAMIC)	VCG1057	C 3803	CAPACITOR(CERAMIC)	VCG1057
	C 1801	CAPACITOR(CERAMIC)	VCG1057	C 3804	CAPACITOR(CERAMIC)	VCG1057
	C 1802		CKSQYB225K10	C 4501	CAPACITOR(CERAMIC)	VCG1057
	C 1803		CCSSCH221J50	C 4502	CAPACITOR(CERAMIC)	VCG1057
	C 1804		CKSSYB331K50	C 4503	CAPACITOR(CERAMIC)	VCG1057
	C 1805		CKSSYB473K10	C 4504		CKSSYF104Z16
	C 1811	CAPACITOR(CERAMIC)	VCG1057	C 4505	CAPACITOR(CERAMIC)	VCG1057
	C 1812		CKSQYB225K10	C 4506		CKSSYF104Z16
	C 1813		CCSSCH101J50	C 4507		CEVW101M16
	C 1814		CCSSCH151J50	C 4508	CHIP ELECT.CAPACITOR	CEVW221M4
	C 1815		CKSSYB473K10	C 4509	CHIP ELECT.CAPACITOR	CEVW221M4
E	C 2305	CAPACITOR(CERAMIC)	VCG1058	C 4511		CKSQYB475K6R3
	C 2501	CAPACITOR(CERAMIC)	VCG1057	C 4513		CKSQYB475K6R3
	C 2502	CAPACITOR(CERAMIC)	VCG1057	C 4515		CEVW470M6R3
	C 2503	CAPACITOR(CERAMIC)	VCG1057	C 4516		CEVW100M16
	C 2504	CAPACITOR(CERAMIC)	VCG1057	C 4522	CAPACITOR(CERAMIC)	VCG1057
	C 2505	CAPACITOR(CERAMIC)	VCG1057	C 4524		CKSQYB475K6R3
	C 2506		DCH1201	C 4525		CKSQYB475K6R3
	C 3103		CEVW101M16	C 4531	CAPACITOR(CERAMIC)	VCG1057
	C 3104	CAPACITOR(CERAMIC)	VCG1057	C 4532		CKSSYB103K16
	C 3105		CKSSYF104Z16	C 4533	CAPACITOR(CERAMIC)	VCG1057
F	C 3106		CKSSYB102K50	C 4534		DCH1201
	C 3107	CAPACITOR(CERAMIC)	VCG1057	C 4535		CKSSYB102K50
	C 3108	CHIP ELECT.CAPACITOR	CEVW221M4	C 4536		CKSSYB102K50
	C 3201	ELECT. CAPACITOR	CEAT102M6R3	C 4537		CKSSYB102K50

5		6		7		8	
<u>Mark No.</u>	<u>Description</u>	<u>Part No.</u>	<u>Mark No.</u>	<u>Description</u>	<u>Part No.</u>		
C 4539		CKSSYB102K50	C 5601	CAPACITOR(CERAMIC)	VCG1057		
C 4540		CKSSYB102K50	C 5602	CAPACITOR(CERAMIC)	VCG1057		
C 4541	CAPACITOR(CERAMIC)	VCG1057	C 5603		CKSSYF104Z16	A	
C 4542		CKSQYB225K10	C 5604		CKSSYB103K16		
C 4543		CKSSYB102K50	C 5605		CKSSYB103K16		
C 4555		CKSQYB475K6R3	C 5606		CKSSYB103K16		
C 4556		CKSQYB475K6R3	C 5607		CKSSYB103K16		
C 4557		CKSSYB103K16	C 5608		CKSSYB103K16		
C 4558		CEVW101M16	C 5609		CKSSYB103K16		
C 4559		CEVW101M16	C 5610		CKSSYB103K16		
C 4562	CAPACITOR(CERAMIC)	VCG1057	C 5611		CKSSYB103K16		
C 4563	CAPACITOR(CERAMIC)	VCG1057	C 5612		CKSSYF104Z16		
C 4567	CAPACITOR(CERAMIC)	VCG1057	C 5613	CHIP ELECT.CAPACITOR	CEVW101M4		
C 4570	CAPACITOR(CERAMIC)	VCG1057	C 5614		CKSSYB103K16	B	
C 4571		CKSQYB475K6R3	C 5615		CKSSYF104Z16		
C 4572	CHIP ELECT.CAPACITOR	CEVW221M4	C 5616		CKSSYF104Z16		
C 4573		CKSQYB475K6R3	C 5617		CKSSYB103K16		
C 4581		CEVW101M16	C 5622		CKSSYB103K16		
C 4585		CKSSYF104Z16	C 5623		CKSSYB103K16		
C 4586		CEVW101M16	C 5624		CKSSYB103K16		
C 4701	CAPACITOR(CERAMIC)	VCG1057	C 5625		CKSSYB103K16		
C 4702	CAPACITOR(CERAMIC)	VCG1057	C 5626		CKSSYB103K16		
C 4703	CAPACITOR(CERAMIC)	VCG1057	C 5627		CKSSYB103K16		
C 4704		CKSSYB102K50	C 5628		CKSSYB103K16		
C 4705		CKSSYB102K50	C 5629		CKSSYB103K16	C	
C 4706		CKSSYB102K50	C 5630		CKSSYB103K16		
C 5104		CKSSYF104Z16	C 5631		CKSSYB103K16		
C 5105	CAPACITOR(CERAMIC)	VCG1057	C 5632		CKSSYB103K16		
C 5106	CAPACITOR(CERAMIC)	VCG1057	C 5640		CCSSCH120J50		
C 5107	CAPACITOR(CERAMIC)	VCG1057	C 5641		CCSSCH120J50		
C 5108	CAPACITOR(CERAMIC)	VCG1057	C 5702	CAPACITOR(CERAMIC)	VCG1057		
C 5109		CKSSYF104Z16	C 5704		CEVW1R0M50		
C 5110	CAPACITOR(CERAMIC)	VCG1057	C 5705		CKSSYB102K50		
C 5111	CAPACITOR(CERAMIC)	VCG1057	C 5706		CKSSYB102K50		
C 5112	CAPACITOR(CERAMIC)	VCG1057	C 5707	CAPACITOR(CERAMIC)	VCG1057		
C 5113		CKSSYF104Z16	C 5708	CHIP ELECT.CAPACITOR	CEVW221M4	D	
C 5114		CKSSYF104Z16	C 5801	CAPACITOR(CERAMIC)	VCG1057		
C 5115	CAPACITOR(CERAMIC)	VCG1057	C 5802		CKSSYB102K50		
C 5116	CAPACITOR(CERAMIC)	VCG1057	C 5803	CAPACITOR(CERAMIC)	VCG1057		
C 5117		CCSSCH120J50	C 5804		CKSSYB102K50		
C 5118		CCSSCH120J50	C 5805	CAPACITOR(CERAMIC)	VCG1057		
C 5119		CKSSYB271K50	C 5806	CAPACITOR(CERAMIC)	VCG1057		
C 5120	CAPACITOR(CERAMIC)	VCG1057	C 5807	CAPACITOR(CERAMIC)	VCG1057		
C 5121	CHIP ELECT.CAPACITOR	CEVW101M4	C 5808	CAPACITOR(CERAMIC)	VCG1057		
C 5122	CHIP ELECT.CAPACITOR	CEVW101M4	C 5809	CHIP ELECT.CAPACITOR	CEVW221M4		
C 5123	CAPACITOR(CERAMIC)	VCG1057	C 5812		CKSSYF104Z16	E	
C 5132	CAPACITOR(CERAMIC)	VCG1057	C 5813		CKSSYF104Z16		
C 5133	CAPACITOR(CERAMIC)	VCG1057	C 5814		CKSRYF104Z16		
C 5205	CAPACITOR(CERAMIC)	VCG1057	C 5815		CKSRYB104K25		
C 5209		CKSSYF104Z16	C 5816		CKSRYB104K25		
C 5210		CEVW101M16	C 5817		CKSRYB104K25		
C 5211		CKSSYB102K50	C 5818		CKSRYB104K25		
C 5212		CKSQYB225K10	C 5819		CKSSYB102K50		
C 5213	CAPACITOR(CERAMIC)	VCG1057	C 5820	CAPACITOR(CERAMIC)	VCG1057		
C 5216		CKSSYB102K50	C 5821		CKSSYB102K50		
C 5217	CAPACITOR(CERAMIC)	VCG1057	C 5822		CKSSYB102K50		
C 5218		CKSSYB102K50					
C 5219		CKSSYB102K50					
C 5222		CKSSYF104Z16					
C 5223		CKSSYB102K50					

Mark No. Description Part No.

D SERVICE MAIN ASSY (DVR-550H-S, -AV)

Mark No. Description Part No.

MISCELLANEOUS

A	IC 200 FLASH ROM IC	SST25V016BCS
	IC 201 SDRAM(64M)	K4S641632K-UC60
	IC 501 7CH DRIVER IC	BD7956FS
	IC 1001 DVDR IC	MC-10050F1-107LU1A
	IC 1102 FLASH ROM	VYW2404
	IC 1201 DDR-SDRAM(512MBIT)	EDD5116AFTA-6B
	IC 1221 DDR-SDRAM(512MBIT)	EDD5116AFTA-6B
	IC 1301 IC	NJM12904V
	IC 1302 IC	NJM12904V
	IC 3101 AD CONVERTER IC	AK5359ET
	IC 3201 IC	PCM1742KE
B	IC 3202 OP-AMP IC	UPC4570G2
	IC 3701 IC	TC7WH34FU
	IC 3702 IC	TC7SH08FUS1
	IC 3707 RESET IC	PST3813U
	IC 4501 FUSE	CEK1285
	IC 4502 FUSE	CEK1285
	⚠ IC 4511 REGULATOR IC	S-1170B33UC-OTS
	⚠ IC 4521 REGULATOR IC	S-1170B25UC-OTK
	⚠ IC 4531 REGULATOR IC	MM1701WH
	⚠ IC 4541 REGULATOR IC (3.3V)	MM1563DF
	⚠ IC 4552 REGULATOR IC	S-1170B50UC-OUJ
C	⚠ IC 4561 REGULATOR IC	S-1112B50MC-L7J
	⚠ IC 4562 REGULATOR IC	S-1112B33MC-L6S
	⚠ IC 4571 REGULATOR IC	S-1132B18-U5
	IC 4701 LOGIC IC	TC74VCX245FK
	IC 4702 IC	TC7SZ08FU
	IC 4703 LOGIC IC	TC74VHC125FK
	IC 5103 DV-PHY IC	UPD72852AGB-8EU
	IC 5602 SATA BRIDGE IC	88SA8040B1-TBC1
	IC 5801 HDMI TRANSMITER	SII9002CSU
	IC 5802 IC	TC7MB3257FK
D	Q 102 TRANSISTOR	RT1N141U
	Q 1801 TRANSISTOR	2SA1576A
	Q 1811 TRANSISTOR	2SA1576A
	Q 2501 TRANSISTOR	2SA1576A
	Q 2502 TRANSISTOR	2SA1576A
	Q 2503 TRANSISTOR	2SA1576A
	Q 2504 TRANSISTOR	2SA1576A
	Q 2505 TRANSISTOR	2SA1576A
	Q 3301 TRANSISTOR	2SA1576A
	Q 3302 TRANSISTOR	2SC4081
	Q 4581 TRANSISTOR	2SC4081
E	Q 5701 TRANSISTOR	2SC4081
	Q 5801 CHIP TRANSISTOR	HN1C01FU
	Q 5802 CHIP TR (PNP X 2)	UMB1N
	Q 5804 DIGITAL TRANSISTOR	DTC124EUA
	Q 5805 TRANSISTOR	2SA1576A
	Q 5808 MOS FET	2SK2034
	Q 5809 TRANSISTOR	UMD2N
	Q 5810 CHIP TRANSISTOR	UMF21N
	D 101 LED	SML-310YT
	D 3201 DIODE	DAN202U
	D 3711 CHIP DIODE	RB501V-40
F	D 3712 CHIP DIODE	RB501V-40
	D 4521 CHIP DIODE	RB501V-40
	D 4552 CHIP DIODE	RB501V-40

D	4571 CHIP DIODE	RB501V-40
L	105 CHIP COIL	BTH1103
L	1001 EMI FILTER	DTL1106
L	1002 EMI FILTER	DTL1106
L	1003 EMI FILTER	DTL1106
L	1004 EMI FILTER	DTL1106
L	1005 INDUCTOR	LCTC150K2125
L	1021 EMI FILTER	DTL1106
L	1022 EMI FILTER	DTL1106
L	1023 EMI FILTER	DTL1106
L	1024 EMI FILTER	DTL1106
L	1025 EMI FILTER	DTL1106
L	1801 CHIP COIL	LCYA390J2520
L	1811 INDUCTOR	LCYA150J2520
L	1821 EMI FILTER	DTL1106
L	1831 EMI FILTER	DTL1106
L	3301 CHIP COIL	LCYA180J2520
L	3302 INDUCTOR	LCYA100J2520
L	5101 INDUCTOR	CTF1305
L	5122 EMI FILTER	DTL1106
L	5601 EMI FILTER	DTL1106
L	5701 INDUCTOR	CTF1382
L	5801 COIL	ATH7022
L	5802 COIL	ATH7022
L	5803 COIL	ATH7022
L	5804 COIL	ATH7022
L	5805 EMI FILTER	DTL1106
JA	5701 JACK 1P PIN JACK	VKB1159
JA	5801 HDMI CONNECTOR	AKP1278
X	101 CERAMIC RESONATOR	DSS1157
X	1001 CRYSTAL RESONATOR	VSS1220
X	1002 CRYSTAL RESONATOR	VSS1172
X	5101 CRYSTAL	VSS1211
X	5502 CRYSTAL	VSS1214
CN	101 CONNECTOR 50P	DKN1404
CN	103 CONNECTOR 14P	VKN2030
CN	201 CONNECTOR 10P	VKN2029
CN	501 FFC CONNECTOR	DKN1312
CN	502 4P FFC CONNECTOR	DKN1288
CN	601 5P FFC CONNECTOR	DKN1402
CN	1401 CONNECTOR 14P	VKN2030
CN	1402 7P FFC CONNECTOR	RKN1048
CN	2301 40P CONNECTOR	VKN2065
CN	3801 FFC CONNECTOR 18P	VKN1811
CN	4501 KR CONNECTOR	S13B-PH
CN	4701 CONNECTOR	VKN2047
CN	5101 CONNECTOR	VKN1932
CN	5604 SATA PLUG HEADER	VKN2063
	RADIATION SHEET	VEB1360
	SCREW	BBZ30P060FTC
	HEATSINK(AL)	VNH1079

RESISTORS

R	104	RS1/16SS123J
R	105	RS1/16SS0R0J
R	107	RS1/16SS473J
R	108	RS1/16SS682J
R	109	RS1/16SS622J
R	110	RS1/16SS102J
R	111	RS1/16SS474J

5		6		7		8	
<u>Mark No.</u>	<u>Description</u>	<u>Part No.</u>	<u>Mark No.</u>	<u>Description</u>	<u>Part No.</u>		
R 112		RS1/16SS474J	R 273		RS1/10S0R0J		
R 114		RS1/16SS333J	R 274		RS1/10S0R0J		
R 115		RS1/16SS0R0J	R 281		RS1/16SS0R0J		
R 116		RS1/16SS332J	R 301		RS1/16SS473J		A
R 117		RS1/16SS680J	R 306		RS1/16SS222J		
R 119		RS1/16SS0R0J	R 307		RS1/16SS222J		
R 124		RS1/16SS0R0J	R 310		RS1/16SS102J		
R 128		RS1/16SS0R0J	R 311		RS1/16SS102J		
R 129		RS1/16SS0R0J	R 312		RS1/16SS102J		
R 130		RS1/16SS221J	R 313		RS1/16SS473J		
R 131		RS1/16SS221J	R 314		RS1/16SS102J		
R 132		RS1/16SS221J	R 317		RAB4CQ330J		
R 133		RS1/16SS221J	R 318		RAB4CQ330J		
R 134		RS1/16SS473J	R 319		RAB4CQ330J		B
R 135		RS1/16SS221J	R 320		RAB4CQ330J		
R 136		RS1/16SS221J	R 501		DCN1171		
R 137		RS1/16SS221J	R 502		DCN1172		
R 138		RS1/16SS473J	R 503		RS1/16SS102J		
R 139		RS1/16SS221J	R 504		RS1/16SS102J		
R 165		RS1/16SS821J	R 505		RS1/16SS123J		
R 166		RS1/16SS821J	R 506		RS1/16SS102J		
R 167		RS1/16SS821J	R 507		RS1/16SS102J		
R 168		RS1/16SS0R0J	R 510		RS1/10S1R8J		
R 170		RS1/16SS332J	R 511		RS1/10S1R8J		
R 171		RS1/16SS332J	R 515		RS1/16SS333J		C
R 172		RS1/16SS332J	R 516		RS1/16SS123J		
R 174		RS1/16S4701F	R 601		RS1/16SS103J		
R 192		RS1/16S101J	R 602		RS1/16SS103J		
R 193		RS1/16SS0R0J	R 603		RS1/16SS102J		
R 201		RS1/16SS103J	R 604		RS1/16SS102J		
R 202		RS1/16SS330J	R 1001		RS1/16SS103J		
R 203		RS1/16SS330J	R 1003	CHIP RESISTOR	RS1/16S6800F		
R 204		RAB4CQ330J	R 1004		RS1/16S4700F		
R 205		RAB4CQ330J	R 1013		RS1/16SS103J		
R 206		RAB4CQ330J	R 1016		RS1/16SS103J		
R 210		RS1/16SS330J	R 1017		RS1/16SS0R0J		D
R 211		RS1/16SS0R0J	R 1018		RS1/16SS0R0J		
R 219	RESISTOR ARRAY	RAB4CQ472J	R 1019		RS1/16SS0R0J		
R 220	RESISTOR ARRAY	RAB4CQ472J	R 1021		RS1/16SS103J		
R 221		RS1/16SS473J	R 1027		RS1/16SS103J		
R 222		RS1/16SS473J	R 1028		RS1/16SS103J		
R 223		RS1/16SS220J	R 1029		RS1/16SS820J		
R 230		RS1/16SS0R0J	R 1030		RS1/16SS101J		
R 233		RS1/16SS0R0J	R 1031		RS1/16SS221J		
R 234		RS1/16SS0R0J	R 1032	RESISTOR ARRAY	RAB4CQ103J		
R 236		RS1/16SS220J	R 1033	RESISTOR ARRAY	RAB4CQ103J		
R 237		RS1/16SS103J	R 1034	RESISTOR ARRAY	RAB4CQ103J		E
R 238		RS1/16SS220J	R 1035	RESISTOR ARRAY	RAB4CQ103J		
R 239		RS1/16SS103J	R 1036		RS1/16S43R0D		
R 240		RS1/16SS220J	R 1037	CHIP RESISTOR	RS1/16S1000F		
R 241		RS1/16SS103J	R 1039		RS1/16S43R0D		
R 242		RS1/16SS220J	R 1040	CHIP RESISTOR	RS1/16S1000F		
R 243		RS1/16SS103J	R 1066		RS1/16SS473J		
R 244		RS1/16SS220J	R 1067		RS1/16SS473J		
R 245		RS1/16SS103J	R 1068		RS1/16SS473J		
R 248		RS1/16SS103J	R 1069		RS1/16SS473J		
R 252		RS1/16SS103J	R 1071		RS1/16SS103J		
R 253		RS1/16SS103J	R 1103		RS1/16SS0R0J		F
R 256		RS1/16SS103J	R 1107		RS1/16SS0R0J		
R 271		RS1/10S0R0J	R 1110		RS1/16SS0R0J		

<u>Mark No.</u>	<u>Description</u>	<u>Part No.</u>	<u>Mark No.</u>	<u>Description</u>	<u>Part No.</u>
R 1111		RS1/16SS104J	R 1303		RS1/16S1001F
R 1132		RS1/16SS470J	R 1312		RS1/16S1001F
R 1153		RS1/16SS472J	R 1313		RS1/16S1001F
A					
R 1161		RS1/16SS472J	R 1314		RS1/16S0R0J
R 1163		RS1/16SS472J	R 1401		RS1/16SS220J
R 1164		RS1/16SS472J	R 1402		RS1/16SS220J
R 1181		RS1/16SS103J	R 1403		RS1/16SS220J
R 1182		RS1/16SS103J	R 1404		RS1/16SS220J
R 1191		RS1/16SS472J	R 1405		RS1/16SS220J
R 1199		RS1/16SS103J	R 1406		RS1/16SS220J
R 1205		RS1/16SS103J	R 1407		RS1/16SS220J
R 1219		RS1/16SS0R0J	R 1411	RESISTOR ARRAY	RAB4CQ103J
R 1240		RS1/16SS220J	R 1412		RS1/16SS103J
B					
R 1241	RESISTOR ARRAY	RAB4CQ0R0J	R 1413		RS1/16SS473J
R 1242	RESISTOR ARRAY	RAB4CQ0R0J	R 1414		RS1/16SS220J
R 1243		RS1/16SS0R0J	R 1415		RS1/16SS220J
R 1244		RS1/16SS330J	R 1416		RS1/16SS220J
R 1245	RESISTOR ARRAY	RAB4CQ220J	R 1421		RS1/16SS103J
R 1246	RESISTOR ARRAY	RAB4CQ220J	R 1422		RS1/16SS103J
R 1247		RS1/16SS220J	R 1802		RS1/16SS221J
R 1248	RESISTOR ARRAY	RAB4CQ0R0J	R 1803		RS1/16SS331J
R 1249	RESISTOR ARRAY	RAB4CQ0R0J	R 1804		RS1/16SS330J
R 1250		RS1/16SS0R0J	R 1812		RS1/16SS221J
R 1251		RS1/16SS330J	R 1813		RS1/16SS331J
R 1252		RS1/16SS330J	R 1814		RS1/16SS330J
R 1255	RESISTOR ARRAY	RAB4CQ220J	R 2301		RS1/16SS332J
R 1256	RESISTOR ARRAY	RAB4CQ220J	R 2302		RS1/16SS0R0J
R 1257		RS1/16SS220J	R 2304		RS1/16SS0R0J
R 1258		RS1/16SS220J	R 2316		RS1/16SS103J
R 1260		RS1/16SS220J	R 2501		RS1/16SS681J
R 1261	RESISTOR ARRAY	RAB4CQ0R0J	R 2502		RS1/16S1500F
R 1262	RESISTOR ARRAY	RAB4CQ0R0J	R 2504		RS1/16SS681J
R 1263		RS1/16SS0R0J	R 2505		RS1/16S1500F
R 1264		RS1/16SS330J	R 2506		RS1/16S0R0J
R 1265	RESISTOR ARRAY	RAB4CQ220J	R 2507		RS1/16SS681J
R 1266	RESISTOR ARRAY	RAB4CQ220J	R 2508		RS1/16S1500F
R 1267		RS1/16SS220J	R 2510		RS1/16SS681J
R 1268	RESISTOR ARRAY	RAB4CQ0R0J	R 2511		RS1/16S1500F
R 1269	RESISTOR ARRAY	RAB4CQ0R0J	R 2513		RS1/16SS681J
R 1270		RS1/16SS0R0J	R 2514		RS1/16S1500F
R 1271		RS1/16SS330J	R 3002		RS1/16SS0R0J
R 1272		RS1/16SS330J	R 3003		RS1/16SS0R0J
R 1273	RESISTOR ARRAY	RAB4CQ220J	R 3004		RS1/16SS0R0J
R 1274	RESISTOR ARRAY	RAB4CQ220J	R 3005	RESISTOR ARRAY	RAB4CQ103J
R 1275		RS1/16SS220J	R 3006		RS1/16SS0R0J
R 1276		RS1/16SS220J	R 3007		RS1/16SS0R0J
R 1277		RS1/16SS0R0J	R 3008		RS1/16SS0R0J
R 1278		RS1/16SS0R0J	R 3009		RS1/16SS0R0J
R 1279		RS1/16SS391J	R 3010		RS1/16SS0R0J
R 1281	RESISTOR ARRAY	RAB4CQ470J	R 3011		RS1/16SS0R0J
R 1282	RESISTOR ARRAY	RAB4CQ470J	R 3012		RS1/16SS0R0J
R 1283	RESISTOR ARRAY	RAB4CQ470J	R 3101		RS1/16SS0R0J
R 1284		RS1/16SS470J	R 3102		RS1/16SS0R0J
R 1285		RS1/16SS470J	R 3103		RS1/16SS0R0J
R 1286		RS1/16SS470J	R 3104		RS1/16SS0R0J
R 1287	RESISTOR ARRAY	RAB4CQ470J	R 3105		RS1/16SS105J
R 1288		RS1/16SS220J	R 3106		RS1/16SS103J
R 1289		RS1/16SS220J	R 3107		RS1/16SS470J
R 1301		RS1/16S4700F	R 3108		RS1/16SS470J
R 1302		RS1/16S1001F	R 3109		RS1/16SS470J

5		6		7		8	
<u>Mark No.</u>	<u>Description</u>	<u>Part No.</u>	<u>Mark No.</u>	<u>Description</u>	<u>Part No.</u>		
R 3111		RS1/16SS0R0J	R 3816		RS1/16SS820J		
R 3113		RS1/16SS103J	R 3817		RS1/16SS820J		
R 3201		RS1/16SS470J	R 3818		RS1/16SS220J		
R 3202		RS1/16SS470J	R 3820		RS1/16SS820J		A
R 3203		RS1/16SS470J	R 3821		RS1/16SS220J		
R 3204		RS1/16SS0R0J	R 3823		RS1/16SS820J		
R 3206		RS1/16SS470J	R 3824	RESISTOR ARRAY	RAB4CQ820J		
R 3207		RS1/16SS470J	R 3828	RESISTOR ARRAY	RAB4CQ223J		
R 3208		RS1/16SS470J	R 3829	RESISTOR ARRAY	RAB4CQ223J		
R 3209		RS1/16SS104J	R 3830	RESISTOR ARRAY	RAB4CQ223J		
R 3210		RN1/16SE1201D	R 3831	RESISTOR ARRAY	RAB4CQ223J		
R 3211		RN1/16SE1002D	R 3832	RESISTOR ARRAY	RAB4CQ223J		
R 3213		RS1/16SS681J	R 3833	RESISTOR ARRAY	RAB4CQ223J		
R 3214		RS1/16SS682J	R 3835		RS1/16SS330J		B
R 3215		RS1/16SS223J	R 3837		RAB4CQ330J		
R 3216		RN1/16SE1201D	R 3838		RAB4CQ330J		
R 3217		RN1/16SE1002D	R 3839		RAB4CQ330J		
R 3218		RN1/16SE2202D	R 3840		RAB4CQ330J		
R 3219		RS1/16SS682J	R 3841		RS1/16SS820J		
R 3220		RS1/16SS101J	R 3842		RS1/16SS562J		
R 3221		RS1/16SS101J	R 3843		RS1/16SS220J		
R 3222		RS1/16SS682J	R 3844		RS1/16SS220J		
R 3223		RN1/16SE2202D	R 3845		RS1/16SS820J		
R 3224		RS1/16SS101J	R 3846		RS1/16SS102J		
R 3227		RS1/16SS101J	R 3847		RS1/16SS220J		C
R 3228		RS1/16SS103J	R 3848		RS1/16SS820J		
R 3229		RS1/16SS103J	R 3849		RS1/16SS103J		
R 3230		RS1/10S0R0J	R 3850		RS1/16SS330J		
R 3232		RS1/16SS0R0J	R 3851		RAB4CQ330J		
R 3233		RS1/16SS0R0J	R 3857		RS1/16SS0R0J		
R 3234		RS1/16SS0R0J	R 3862		RS1/16SS0R0J		
R 3301		RS1/16SS470J	R 3871		RS1/16SS223J		
R 3302		RS1/16SS0R0J	R 4501		RS1/10S0R0J		
R 3305		RS1/16SS331J	R 4511		RS1/16SS0R0J		
R 3306		RS1/16S4700F	R 4521		RS1/16SS682J		
R 3307	CHIP RESISTOR	RS1/16SS1801F	R 4526		RS1/16SS153J		D
R 3308		RS1/16SS100J	R 4531		RS1/16SS0R0J		
R 3309		RS1/16SS681J	R 4541		RS1/16SS0R0J		
R 3310		RS1/16SS103J	R 4551		RS1/10S0R0J		
R 3315		RS1/16SS681J	R 4552		RS1/10S0R0J		
R 3320		RS1/16SS681J	R 4553		RS1/10S0R0J		
R 3327		RS1/16SS681J	R 4554		RS1/10S0R0J		
R 3336		RS1/16SS0R0J	R 4556		RS1/10S0R0J		
R 3337		RS1/16SS103J	R 4558		RS1/16SS223J		
R 3341		RS1/16SS0R0J	R 4559		RS1/16SS0R0J		
R 3342		RS1/16SS103J	R 4573		RS1/16SS0R0J		
R 3703		RS1/16SS101J	R 4574		RS1/16S0R0J		E
R 3704		RS1/16SS101J	R 4575		RS1/16S0R0J		
R 3705		RS1/16SS101J	R 4581		RS1/16SS101J		
R 3708		RS1/16SS103J	R 4701	RESISTOR ARRAY	RAB4CQ101J		
R 3715		RS1/16SS0R0J	R 4702	RESISTOR ARRAY	RAB4CQ101J		
R 3716		RS1/16SS330J	R 4703		RS1/16SS101J		
R 3720		RS1/16SS0R0J	R 4704		RS1/16SS0R0J		
R 3738		RS1/16SS103J	R 4705		RS1/16SS0R0J		
R 3808		RS1/16SS101J	R 4706		RS1/16SS0R0J		
R 3810		RAB4CQ330J	R 4707		RS1/16SS103J		
R 3811		RAB4CQ330J	R 4708	RESISTOR ARRAY	RAB4CQ103J		
R 3812		RAB4CQ330J	R 4709	RESISTOR ARRAY	RAB4CQ103J		F
R 3813		RAB4CQ330J	R 4710		RS1/16SS103J		
R 3814		RS1/16SS220J	R 4711		RS1/16SS103J		

<u>Mark No.</u>	<u>Description</u>	<u>Part No.</u>	<u>Mark No.</u>	<u>Description</u>	<u>Part No.</u>
R 4712		RS1/16SS103J	R 5615		RS1/16SS102J
R 4713		RS1/16SS103J	R 5616		RS1/16SS103J
R 4721	RESISTOR ARRAY	RAB4CQ101J	R 5618		RS1/16SS103J
A					
R 4722	RESISTOR ARRAY	RAB4CQ101J	R 5619		RS1/16SS102J
R 4723		RS1/16SS470J	R 5622		RS1/16SS820J
R 4724		RS1/16SS220J	R 5623		RS1/16SS820J
R 4725		RS1/16SS220J	R 5624		RS1/16SS820J
R 4726		RS1/16SS220J	R 5626		RS1/16SS220J
R 4727		RS1/16SS103J	R 5627		RS1/16SS820J
R 4728		RS1/16SS103J	R 5628		RS1/16SS220J
R 4729		RS1/16SS0R0J	R 5629		RS1/16SS820J
R 4731		RS1/16SS472J	R 5630		RS1/16SS820J
R 4732		RS1/16SS472J	R 5631		RS1/16SS220J
B					
R 5101	RESISTOR ARRAY	RAB4CQ104J	R 5632		RAB4CQ330J
R 5102	RESISTOR ARRAY	RAB4CQ104J	R 5638		RAB4CQ330J
R 5103		RS1/16SS104J	R 5642		RAB4CQ330J
R 5104		RS1/16SS104J	R 5646		RAB4CQ330J
R 5105	RESISTOR ARRAY	RAB4CQ680J	R 5650		RS1/16SS820J
R 5106	RESISTOR ARRAY	RAB4CQ680J	R 5651		RS1/16S1202F
R 5107		RS1/16SS680J	R 5652		RS1/16SS101J
R 5108		RS1/16SS680J	R 5657		RS1/16SS102J
R 5109		RS1/16SS470J	R 5658		RS1/16SS102J
R 5110		RS1/16SS103J	R 5659		RS1/16SS102J
C					
R 5111		RS1/16SS102J	R 5661		RS1/16SS102J
R 5113		RS1/16SS103J	R 5664		RS1/16S0R0J
R 5114		RS1/16SS103J	R 5672		RS1/16S0R0J
R 5115		RS1/16SS103J	R 5688		RS1/16SS105J
R 5116		RS1/16SS103J	R 5689		RS1/16SS152J
R 5117		RS1/16SS104J	R 5690		RS1/16SS0R0J
R 5118		RN1/16SE9101D	R 5692		RS1/16SS0R0J
R 5119	CHIP RESISTOR	RS1/16S56R0D	R 5693		RS1/16SS0R0J
R 5120	CHIP RESISTOR	RS1/16S56R0D	R 5702		RS1/16SS471J
R 5121	CHIP RESISTOR	RS1/16S56R0D	R 5703		RS1/16SS681J
R 5122	CHIP RESISTOR	RS1/16S56R0D	R 5704		RS1/16SS151J
R 5123		RS1/16SS103J	R 5705		RS1/16S0R0J
R 5124		RS1/16SS103J	R 5706	CHIP RESISTOR	RS1/16S75R0F
R 5125		RS1/16SS102J	R 5707		RS1/16SS104J
R 5127		RS1/16SS103J	R 5708		RS1/16SS391J
R 5129		RS1/16SS820J	R 5803		RS1/16S0R0J
R 5130		RS1/16SS0R0J	R 5804		RS1/16SS473J
R 5131		RN1/16SE5101D	R 5805		RS1/16SS472J
R 5132		RS1/16SS0R0J	R 5806		RS1/16SS102J
R 5133		RS1/16SS0R0J	R 5807		RS1/16SS562J
R 5134		RS1/16SS0R0J	R 5808		RS1/16SS472J
R 5135		RS1/16SS0R0J	R 5809		RS1/16SS272J
R 5140		RS1/16SS103J	R 5812		RS1/16SS472J
R 5141		RS1/16SS0R0J	R 5813		RS1/16SS272J
R 5206		RS1/16SS103J	R 5814		RS1/16SS472J
R 5208		RS1/16SS103J	R 5815		RS1/16SS272J
R 5214		RS1/16SS473J	R 5817		RS1/16SS472J
R 5215		RS1/16SS473J	R 5818		RS1/16SS472J
R 5445		RS1/10S0R0J	R 5821		RS1/16SS472J
R 5606		RS1/16SS820J	R 5822		RS1/16SS472J
R 5607		RS1/16SS820J	R 5824		RS1/10S0R0J
R 5608		RS1/16SS103J	R 5825	RESISTOR ARRAY	RAB4CQ220J
R 5609		RS1/16SS103J	R 5826	RESISTOR ARRAY	RAB4CQ220J
R 5610		RS1/16SS102J	R 5827	RESISTOR ARRAY	RAB4CQ220J
R 5612		RS1/16SS103J	R 5828	RESISTOR ARRAY	RAB4CQ220J
R 5613		RS1/16SS102J	R 5829		RS1/16SS560J
R 5614		RS1/16SS102J	R 5831		RS1/16SS0R0J

5		6
<u>Mark No.</u>	<u>Description</u>	<u>Part No.</u>
R 5832		RS1/16S0R0J
R 5833		RS1/16SS220J
R 5834		RS1/16SS220J
R 5836		RS1/16SS103J
R 5837		RS1/16SS0R0J
R 5838		RS1/16SS330J
R 5839		RS1/16SS471J
R 5842		RS1/16SS331J
R 5843		RS1/16SS331J
R 5844		RS1/16SS331J
R 5845		RS1/16SS331J
R 5846		RS1/16SS472J
R 5848		RS1/16SS472J
R 5852		RS1/16SS103J
R 5853		RS1/16SS103J
R 5854		RS1/16SS103J
R 5855	RESISTOR ARRAY	RAB4CQ100J
R 5856		RS1/16SS103J
R 5857		RS1/16SS103J
R 5859		RS1/16SS103J
R 5861		RS1/16SS103J
R 5862		RS1/16SS472J
R 5863		RS1/16SS681J
R 5864		RS1/16SS102J
R 5865		RS1/16SS0R0J
R 5867		RS1/16SS561J
R 5868		RS1/16SS222J
R 5869		RS1/16SS472J
R 5870		RS1/16SS273J
R 6001		RS1/16SS0R0J

CAPACITORS

C 100	CKSSYB102K50
C 101	CKSSYB102K50
C 103	CHIP ELECT.CAPACITOR CEVW221M4
C 104	CAPACITOR(CERAMIC) VCG1057
C 105	CKSSYB102K50
C 106	CKSSYF104Z16
C 107	CKSSYB681K50
C 113	CKSSYB472K25
C 114	CKSSYB472K25
C 115	CKSSYB103K16
C 116	CKSSYB104K10
C 117	CKSSYB102K50
C 120	CKSSYB104K10
C 121	CKSSYB222K50
C 122	CKSSYB222K50
C 124	CKSSYB104K10
C 125	CAPACITOR(CERAMIC) VCG1058
C 127	CKSSYB473K10
C 128	CKSSYB104K10
C 129	CAPACITOR(CERAMIC) VCG1058
C 130	CKSQYB475K6R3
C 131	CKSSYB683K10
C 133	CKSSYB104K10
C 134	CKSSYB104K10
C 135	CKSSYB103K16
C 136	CKSSYB104K10
C 137	CKSSYB682K25
C 140	ELECT. CAPACITOR DCH1199

7		8
<u>Mark No.</u>	<u>Description</u>	<u>Part No.</u>
C 141	ELECT. CAPACITOR	DCH1199
C 142		DCH1201
C 143		DCH1201
C 144		CKSSYB103K16
C 145		CKSSYB103K16
C 146		DCH1201
C 147	ELECT. CAPACITOR	DCH1198
C 148	ELECT. CAPACITOR	DCH1198
C 149		CKSSYB103K16
C 152		CKSSYB102K50
C 153		CEVW100M16
C 154	CAPACITOR(CERAMIC)	VCG1057
C 155	ELECT. CAPACITOR	DCH1199
C 156		CKSSYB182K50
C 157		CKSSYB103K16
C 158		CKSSYB103K16
C 159		CKSSYF104Z16
C 162	CAPACITOR(CERAMIC)	VCG1057
C 163	CHIP ELECT.CAPACITOR	CEVW221M4
C 164		CKSSYB102K50
C 165		CCSSCH220J50
C 166		CCSSCH220J50
C 167		CKSSYF104Z16
C 169		CKSSYB104K10
C 170		CCSSCH470J50
C 171		CKSSYB104K10
C 172		CCSSCH470J50
C 173		CCSSCH470J50
C 174		CCSSCH470J50
C 176		CCSSCH220J50
C 177		CCSSCH220J50
C 180		DCH1201
C 181		CKSQYB475K6R3
C 182		DCH1201
C 187		CKSSYB103K16
C 188		CKSSYB103K16
C 189		CKSSYB102K50
C 194		CKSQYB475K6R3
C 197		CKSSYB104K10
C 199	CAPACITOR(CERAMIC)	VCG1057
C 201		CKSSYB104K10
C 202	CAPACITOR(CERAMIC)	VCG1057
C 280	CAPACITOR(CERAMIC)	VCG1058
C 281	CAPACITOR(CERAMIC)	VCG1058
C 282	CAPACITOR(CERAMIC)	VCG1058
C 283	CAPACITOR(CERAMIC)	VCG1058
C 284	CAPACITOR(CERAMIC)	VCG1058
C 285	CAPACITOR(CERAMIC)	VCG1058
C 286		DCH1201
C 287	CAPACITOR(CERAMIC)	VCG1058
C 288		CKSSYF104Z16
C 289		CKSSYB102K50
C 290		CKSSYF104Z16
C 291		CKSSYB102K50
C 501		CKSSYF104Z16
C 502	CHIP CERAMIC C.	DCH1263
C 503		CKSRYB471K50
C 504		CKSSYB104K10
C 505		CKSRYB104K25
C 508		CKSSYB102K50

	<u>Mark No.</u>	<u>Description</u>	<u>Part No.</u>	<u>Mark No.</u>	<u>Description</u>	<u>Part No.</u>
	C 509		CCSSCH330J50	C 1053		CKSSYB102K50
	C 510		CCSSCH680J50	C 1056	CAPACITOR(CERAMIC)	VCG1057
A	C 511		CKSQYB105K16	C 1057		CKSSYF104Z16
	C 512		CKSRYP104Z16	C 1058		CKSSYB103K16
	C 513		CKSRYP104Z16	C 1059	CAPACITOR(CERAMIC)	VCG1057
	C 514		CKSRYP104K25	C 1060		CKSSYF104Z16
	C 515		CKSRYP104K25	C 1061		CKSSYB102K50
	C 516		CKSSYB104K10	C 1062	CAPACITOR(CERAMIC)	VCG1057
	C 532		CKSSYB104K10	C 1063		CKSSYF104Z16
	C 1001		CKSSYB104K10	C 1064		CKSSYB102K50
	C 1002		CKSSYB104K10	C 1065		CKSSYB102K50
	C 1003	CHIP ELECT.CAPACITOR	CEVW101M4	C 1066	CAPACITOR(CERAMIC)	VCG1057
	C 1004	CAPACITOR(CERAMIC)	VCG1057	C 1067		CKSSYF104Z16
B	C 1005		CKSSYB102K50	C 1068		CKSSYB102K50
	C 1006	CAPACITOR(CERAMIC)	VCG1057	C 1101		CKSSYB102K50
	C 1007	CHIP ELECT.CAPACITOR	GEVW221M4	C 1104	CAPACITOR(CERAMIC)	VCG1057
	C 1008	CAPACITOR(CERAMIC)	VCG1057	C 1105		CKSSYF104Z16
	C 1009	CHIP ELECT.CAPACITOR	GEVW221M4	C 1113	CAPACITOR(CERAMIC)	VCG1057
	C 1010	CAPACITOR(CERAMIC)	VCG1057	C 1202	CAPACITOR(CERAMIC)	VCG1057
	C 1011		CKSSYB102K50	C 1203		CKSSYF104Z16
	C 1012	CHIP ELECT.CAPACITOR	GEVW101M4	C 1204	CAPACITOR(CERAMIC)	VCG1057
	C 1013	CAPACITOR(CERAMIC)	VCG1057	C 1205		CKSSYB103K16
	C 1014		CKSSYB102K50	C 1206		CKSSYB103K16
	C 1015		CKSSYB104K10	C 1207		CKSSYB102K50
C	C 1016		CKSSYB104K10	C 1208	CAPACITOR(CERAMIC)	VCG1057
	C 1017		CKSSYB104K10	C 1209		CKSSYB102K50
	C 1018		CKSSYB104K10	C 1210		CKSSYB102K50
	C 1019		CKSSYB104K10	C 1211		CKSSYF104Z16
	C 1020		CEVW100M16	C 1212		CKSSYF104Z16
	C 1021		DCH1201	C 1213		CKSSYF104Z16
	C 1022	CAPACITOR(CERAMIC)	VCG1057	C 1214		CKSSYF104Z16
	C 1023		CKSSYB102K50	C 1215	CHIP ELECT.CAPACITOR	CEVW101M4
	C 1024	CHIP ELECT.CAPACITOR	GEVW101M4	C 1216	CAPACITOR(CERAMIC)	VCG1057
	C 1025	CAPACITOR(CERAMIC)	VCG1057	C 1217	CAPACITOR(CERAMIC)	VCG1057
	C 1026		CKSSYB102K50	C 1218	CAPACITOR(CERAMIC)	VCG1057
D	C 1027		CKSSYB104K10	C 1219	CAPACITOR(CERAMIC)	VCG1057
	C 1028		CKSSYB104K10	C 1220	CAPACITOR(CERAMIC)	VCG1057
	C 1029		CKSSYB104K10	C 1221	CAPACITOR(CERAMIC)	VCG1057
	C 1030		CKSSYB104K10	C 1222		CKSSYF104Z16
	C 1031		CKSSYB104K10	C 1223	CAPACITOR(CERAMIC)	VCG1057
	C 1032		CKSSYB104K10	C 1224		CKSSYB103K16
	C 1033		CKSSYB104K10	C 1225		CKSSYB103K16
	C 1034		CKSSYB104K10	C 1226		CKSSYB102K50
	C 1035		CKSSYB104K10	C 1227	CAPACITOR(CERAMIC)	VCG1057
	C 1036	CHIP ELECT.CAPACITOR	CEVW101M4	C 1228		CKSSYB102K50
E	C 1037	CAPACITOR(CERAMIC)	VCG1057	C 1229		CKSSYB102K50
	C 1038		CKSSYB102K50	C 1230		CKSSYF104Z16
	C 1039	CHIP ELECT.CAPACITOR	GEVW101M4	C 1231		DCH1201
	C 1040	CAPACITOR(CERAMIC)	VCG1057	C 1235		DCH1201
	C 1041		CKSSYB102K50	C 1236	CHIP ELECT.CAPACITOR	CEVW101M4
	C 1042		CCSSCJ3R0C50	C 1291		CKSSYF104Z16
	C 1043		CCSSCJ3R0C50	C 1301		CKSQYB225K10
	C 1044		CCSSCH5R0C50	C 1302		CKSSYF104Z16
	C 1045		CCSSCH5R0C50	C 1303		CKSSYF104Z16
	C 1047		CKSSYB104K10	C 1304		CEVW470M6R3
	C 1048	CAPACITOR(CERAMIC)	VCG1057	C 1312		CKSSYF104Z16
F	C 1049		CKSSYB102K50	C 1313		CKSSYF104Z16
	C 1050	CHIP ELECT.CAPACITOR	GEVW101M4	C 1315		CKSQYB225K10
	C 1051		DCH1201	C 1316		DCH1201
	C 1052	CAPACITOR(CERAMIC)	VCG1057	C 1401		CKSSYB103K16

Mark No.	Description	Part No.
C 1421	CAPACITOR(CERAMIC)	VCG1057
C 1801	CAPACITOR(CERAMIC)	VCG1057
C 1802		CKSQYB225K10
C 1803		CCSSCH221J50
C 1804		CKSSYB331K50
C 1805		CKSSYB473K10
C 1811	CAPACITOR(CERAMIC)	VCG1057
C 1812		CKSQYB225K10
C 1813		CCSSCH101J50
C 1814		CCSSCH151J50
C 1815		CKSSYB473K10
C 2305	CAPACITOR(CERAMIC)	VCG1058
C 2501	CAPACITOR(CERAMIC)	VCG1057
C 2502	CAPACITOR(CERAMIC)	VCG1057
C 2503	CAPACITOR(CERAMIC)	VCG1057
C 2504	CAPACITOR(CERAMIC)	VCG1057
C 2505	CAPACITOR(CERAMIC)	VCG1057
C 2506		DCH1201
C 3103		CEVW101M16
C 3104	CAPACITOR(CERAMIC)	VCG1057
C 3105		CKSSYF104Z16
C 3106		CKSSYB102K50
C 3107	CAPACITOR(CERAMIC)	VCG1057
C 3108	CHIP ELECT.CAPACITOR	CEVW221M4
C 3201	ELECT. CAPACITOR	CEAT102M6R3
C 3202		CKSSYF104Z16
C 3203		CKSSYB102K50
C 3204		CKSSYB331K50
C 3206		CKSSYF104Z16
C 3207		CEVW470M6R3
C 3211		CEVW101M16
C 3212		CKSSYF104Z16
C 3213		CKSSYB561K50
C 3214		CKSSYB561K50
C 3215		CCSSCH820J50
C 3216		CCSSCH820J50
C 3217		CKSSYF104Z16
C 3218		CEVW101M16
C 3219	CHIP ELECT.CAPACITOR	CEVW221M4
C 3220	CAPACITOR(CERAMIC)	VCG1057
C 3301		CCSRCH7R0D50
C 3302		CCSRCH7R0D50
C 3303		CCSSCH150J50
C 3304		CCSSCH820J50
C 3305		CCSSCH220J50
C 3307		DCH1201
C 3313		CKSQYB103K50
C 3319		CKSQYB103K50
C 3325		CKSQYB103K50
C 3332	CAPACITOR(CERAMIC)	VCG1057
C 3342	CAPACITOR(CERAMIC)	VCG1057
C 3701		CKSSYB103K16
C 3703	CAPACITOR(CERAMIC)	VCG1057
C 3704		DCH1201
C 3705		CKSSYB102K50
C 3706		CKSSYB102K50
C 3707	CAPACITOR(CERAMIC)	VCG1057
C 3738	CAPACITOR(CERAMIC)	VCG1057
C 3801	CAPACITOR(CERAMIC)	VCG1057
C 3802	CAPACITOR(CERAMIC)	VCG1057

Mark No.	Description	Part No.
C 3803	CAPACITOR(CERAMIC)	VCG1057
C 3804	CAPACITOR(CERAMIC)	VCG1057
C 4501	CAPACITOR(CERAMIC)	VCG1057
C 4502	CAPACITOR(CERAMIC)	VCG1057
C 4503	CAPACITOR(CERAMIC)	VCG1057
C 4504		CKSSYF104Z16
C 4505	CAPACITOR(CERAMIC)	VCG1057
C 4506		CKSSYF104Z16
C 4507		CEVW101M16
C 4508	CHIP ELECT.CAPACITOR	CEVW221M4
C 4509	CHIP ELECT.CAPACITOR	CEVW221M4
C 4511		CKSQYB475K6R3
C 4513		CKSQYB475K6R3
C 4515		CEVW470M6R3
C 4516		CEVW100M16
C 4522	CAPACITOR(CERAMIC)	VCG1057
C 4524		CKSQYB475K6R3
C 4525		CKSQYB475K6R3
C 4531	CAPACITOR(CERAMIC)	VCG1057
C 4532		CKSSYB103K16
C 4533	CAPACITOR(CERAMIC)	VCG1057
C 4534		DCH1201
C 4535		CKSSYB102K50
C 4536		CKSSYB102K50
C 4537		CKSSYB102K50
C 4539		CKSSYB102K50
C 4540		CKSSYB102K50
C 4541	CAPACITOR(CERAMIC)	VCG1057
C 4542		CKSQYB225K10
C 4543		CKSSYB102K50
C 4555		CKSQYB475K6R3
C 4556		CKSQYB475K6R3
C 4557		CKSSYB103K16
C 4558		CEVW101M16
C 4559		CEVW101M16
C 4562	CAPACITOR(CERAMIC)	VCG1057
C 4563	CAPACITOR(CERAMIC)	VCG1057
C 4567	CAPACITOR(CERAMIC)	VCG1057
C 4570	CAPACITOR(CERAMIC)	VCG1057
C 4571		CKSQYB475K6R3
C 4572	CHIP ELECT.CAPACITOR	CEVW221M4
C 4573		CKSQYB475K6R3
C 4581		CEVW101M16
C 4585		CKSSYF104Z16
C 4586		CEVW101M16
C 4701	CAPACITOR(CERAMIC)	VCG1057
C 4702	CAPACITOR(CERAMIC)	VCG1057
C 4703	CAPACITOR(CERAMIC)	VCG1057
C 4704		CKSSYB102K50
C 4705		CKSSYB102K50
C 4706		CKSSYB102K50
C 5104		CKSSYF104Z16
C 5105	CAPACITOR(CERAMIC)	VCG1057
C 5106	CAPACITOR(CERAMIC)	VCG1057
C 5107	CAPACITOR(CERAMIC)	VCG1057
C 5108	CAPACITOR(CERAMIC)	VCG1057
C 5109		CKSSYF104Z16
C 5110	CAPACITOR(CERAMIC)	VCG1057
C 5111	CAPACITOR(CERAMIC)	VCG1057
C 5112	CAPACITOR(CERAMIC)	VCG1057

Mark No. Description**Part No.****Mark No. Description****Part No.**

C 5113 CKSSYF104Z16
C 5114 CKSSYF104Z16

C 5817 CKSRYB104K25
C 5818 CKSRYB104K25

A C 5115 CAPACITOR(CERAMIC) VCG1057
C 5116 CAPACITOR(CERAMIC) VCG1057
C 5117 CCSSCH120J50
C 5118 CCSSCH120J50
C 5119 CKSSYB271K50

C 5819 CKSSYB102K50
C 5820 CAPACITOR(CERAMIC) VCG1057
C 5821 CKSSYB102K50
C 5822 CKSSYB102K50

C 5120 CAPACITOR(CERAMIC) VCG1057
C 5121 CHIP ELECT.CAPACITOR CEVW101M4
C 5122 CHIP ELECT.CAPACITOR CEVW101M4
C 5123 CAPACITOR(CERAMIC) VCG1057
C 5132 CAPACITOR(CERAMIC) VCG1057

E SERVICE VDEC ASSY

MISCELLANEOUS

IC 101 REGULATOR IC (3.3V) MM1563DF
IC 102 REGULATOR IC (1.5V) MM1561FF
IC 103 REGULATOR IC S-1112B50MC-L7J
IC 104 3DY/C SEPA & VDEC IC UPD64015AGM-UEU
IC 105 SDRAM(16M) HY57V161610FTP-6

B C 5133 CAPACITOR(CERAMIC) VCG1057
C 5601 CAPACITOR(CERAMIC) VCG1057
C 5602 CAPACITOR(CERAMIC) VCG1057
C 5603 CKSSYF104Z16
C 5604 CKSSYB103K16

Q 102 TRANSISTOR 2SA1576A
Q 103 TRANSISTOR 2SA1576A
Q 104 TRANSISTOR 2SA1576A
Q 105 TRANSISTOR 2SA1576A
Q 106 TRANSISTOR 2SC4081

C 5605 CKSSYB103K16
C 5606 CKSSYB103K16
C 5607 CKSSYB103K16
C 5608 CKSSYB103K16
C 5609 CKSSYB103K16

Q 107 TRANSISTOR 2SC4081
Q 108 TRANSISTOR 2SC4081
Q 109 TRANSISTOR 2SC4081
L 101 INDUCTOR LCYA100J2520
L 102 INDUCTOR LCYA100J2520

C 5610 CKSSYB103K16
C 5611 CKSSYB103K16
C 5612 CKSSYF104Z16
C 5613 CHIP ELECT.CAPACITOR CEVW101M4
C 5614 CKSSYB103K16

L 103 INDUCTOR LCYA100J2520
L 104 INDUCTOR LCYA100J2520
L 105 CHIP COIL LCYA180J2520
L 106 CHIP COIL LCYA180J2520
L 107 CHIP COIL LCYA180J2520

C 5615 CKSSYF104Z16
C 5616 CKSSYF104Z16
C 5617 CKSSYB103K16
C 5622 CKSSYB103K16
C 5623 CKSSYB103K16

L 108 CHIP COIL LCYA180J2520
F 101 EMI FILTER DTL1106
F 102 EMI FILTER DTL1106
F 103 EMI FILTER DTL1106
F 104 EMI FILTER DTL1106

C 5624 CKSSYB103K16
C 5625 CKSSYB103K16
C 5626 CKSSYB103K16
D C 5627 CKSSYB103K16
C 5628 CKSSYB103K16

F 105 EMI FILTER DTL1106
F 106 EMI FILTER DTL1106
F 107 EMI FILTER DTL1106
X 101 CRYSTAL RESONATOR VSS1220
CN103 CONNECTOR POST B2B-PH

C 5629 CKSSYB103K16
C 5630 CKSSYB103K16
C 5631 CKSSYB103K16
C 5632 CKSSYB103K16
C 5640 CCSSCH120J50

CN104 CONNECTOR VKN2047
CN106 CONNECTOR HLEM24S-1

C 5641 CCSSCH120J50
C 5702 CAPACITOR(CERAMIC) VCG1057
C 5704 CEVW1R0M50
C 5706 CKSSYB102K50
E C 5801 CAPACITOR(CERAMIC) VCG1057

RESISTORS

R 102 RS1/16SS103J
R 103 RS1/16SS0R0J
R 104 RS1/16SS470J
R 105 RS1/16SS470J
R 106 RS1/16SS470J

C 5802 CKSSYB102K50
C 5803 CAPACITOR(CERAMIC) VCG1057
C 5804 CKSSYB102K50
C 5805 CAPACITOR(CERAMIC) VCG1057
C 5806 CAPACITOR(CERAMIC) VCG1057

R 107 RS1/16SS470J
R 113 RS1/16SS103J
R 124 RS1/16SS331J
R 125 RS1/16SS331J
R 126 RS1/16SS331J

C 5807 CAPACITOR(CERAMIC) VCG1057
C 5808 CAPACITOR(CERAMIC) VCG1057
C 5809 CHIP ELECT.CAPACITOR CEVW221M4
C 5812 CKSSYF104Z16
F C 5813 CKSSYF104Z16

R 127 RS1/16SS331J
R 128 RS1/16S4700F
R 129 RS1/16S4700F
R 130 RS1/16S4700F
R 131 RS1/16S4700F

C 5814 CKSRYF104Z16
C 5815 CKSRYB104K25
C 5816 CKSRYB104K25

R 133 RS1/10S0R0J

5		6		7		8	
<u>Mark No.</u>	<u>Description</u>	<u>Part No.</u>	<u>Mark No.</u>	<u>Description</u>	<u>Part No.</u>		
R 136	CHIP RESISTOR	RS1/16SS1801F					
R 137	CHIP RESISTOR	RS1/16SS1801F	C 118		CCSSCH220J50		
R 138	CHIP RESISTOR	RS1/16SS1801F	C 119		CCSSCH220J50		
R 139	CHIP RESISTOR	RS1/16SS1801F	C 120		CCSSCH220J50		A
			C 121		CKSSYB102K50		
R 140		RS1/16SS100J	C 122		CKSSYB102K50		
R 141		RS1/16SS100J					
R 142		RS1/16SS100J	C 123		CCSRCH7R0D50		
R 143		RS1/16SS100J	C 124		CCSRCH7R0D50		
R 144		RS1/16SS681J	C 125		CCSRCH7R0D50		
			C 126		CCSRCH7R0D50		
R 145		RS1/16SS681J	C 127		CCSSCH820J50		
R 146		RS1/16SS681J					
R 147		RS1/16SS681J	C 128		CCSSCH820J50		
R 148		RS1/16SS333J	C 129		CCSSCH820J50		
R 149		RS1/16SS473J	C 130		CKSQYB225K10		
			C 131		CKSQYB225K10		B
R 150		RS1/16SS473J	C 132		CCSSCH820J50		
R 151		RS1/16SS473J					
R 152	RESISTOR ARRAY	RAB4CQ103J	C 133		CCSRCH7R0D50		
R 154	RESISTOR ARRAY	RAB4CQ101J	C 134		CCSRCH7R0D50		
R 155	RESISTOR ARRAY	RAB4CQ101J	C 135		CCSRCH7R0D50		
			C 136		CCSRCH7R0D50		
R 156	RESISTOR ARRAY	RAB4CQ101J	C 137		CCSSCH150J50		
R 157		RS1/10S0R0J					
R 158	RESISTOR ARRAY	RAB4CQ101J	C 138		CCSSCH150J50		
R 159		RS1/16SS101J	C 139		CCSSCH150J50		
R 160	RESISTOR ARRAY	RAB4CQ101J	C 140		CCSSCH150J50		
			C 141	CAPACITOR(CERAMIC)	VCG1057		
R 161		RS1/10S0R0J	C 142	CAPACITOR(CERAMIC)	VCG1057		C
R 162	RESISTOR ARRAY	RAB4CQ101J					
R 163		RS1/16SS0R0J	C 143	CAPACITOR(CERAMIC)	VCG1057		
R 164	RESISTOR ARRAY	RAB4CQ101J	C 144	CAPACITOR(CERAMIC)	VCG1057		
R 165	RESISTOR ARRAY	RAB4CQ101J	C 145		CKSQYB103K50		
			C 146		CKSQYB103K50		
R 167	RESISTOR ARRAY	RAB4CQ101J	C 147		CKSQYB103K50		
R 169		RS1/16SS101J					
R 170		RS1/16SS103J	C 148		CKSQYB103K50		
R 171		RS1/16SS473J	C 149		CKSQYB103K50		
R 174		RS1/16SS103J	C 150	CAPACITOR(CERAMIC)	VCG1058		
			C 151	CHIP ELECT.CAPACITOR	CEVW221M4		
R 175		RS1/16SS103J	C 153		CKSSYF104Z16		
R 176	RESISTOR ARRAY	RAB4CQ101J					D
R 180		RS1/16SS101J	C 154		CKSSYF104Z16		
R 181		RS1/16SS101J	C 155		CKSSYF104Z16		
R 182		RS1/16SS0R0J	C 156		CKSSYF104Z16		
			C 157		CKSSYF104Z16		
R 183		RS1/16SS0R0J	C 158		CKSSYF104Z16		
R 184		RS1/16SS0R0J					
R 185		RS1/16SS0R0J	C 159	CAPACITOR(CERAMIC)	VCG1057		
R 186		RS1/16SS472J	C 160		CKSSYB102K50		
R 187		RS1/16SS472J	C 161	CHIP ELECT.CAPACITOR	CEVW221M4		
			C 162		CKSSYF104Z16		
			C 163		CKSSYF104Z16		
<u>CAPACITORS</u>							
C 101		CKSSYF104Z16					
C 102		CEVW101M16	C 164		CKSSYF104Z16		E
C 103	CAPACITOR(CERAMIC)	VCG1057	C 165		CKSSYF104Z16		
C 106	CHIP ELECT.CAPACITOR	CEVW221M4	C 166		CKSSYF104Z16		
C 107	CAPACITOR(CERAMIC)	VCG1057	C 167		CKSSYF104Z16		
			C 168		CKSSYF104Z16		
C 108	CAPACITOR(CERAMIC)	VCG1057					
C 109	CAPACITOR(CERAMIC)	VCG1057	C 169		CKSSYF104Z16		
C 110	CAPACITOR(CERAMIC)	VCG1057	C 170		CKSSYF104Z16		
C 111	CAPACITOR(CERAMIC)	VCG1057	C 171		CKSSYF104Z16		
C 112	CAPACITOR(CERAMIC)	VCG1057	C 172		CKSSYF104Z16		
			C 173		CKSSYF104Z16		
C 113		CKSSYF104Z16					
C 114	CAPACITOR(CERAMIC)	VCG1057	C 174		CKSSYF104Z16		
C 115		CEVW101M16	C 175		CKSSYF104Z16		F
C 116	CHIP ELECT.CAPACITOR	CEVW221M4	C 176	CAPACITOR(CERAMIC)	VCG1057		
C 117		CCSSCH220J50	C 177	CAPACITOR(CERAMIC)	VCG1057		
			C 178		CEVW100M16		

Mark No. Description**Part No.****Mark No. Description****Part No.**

C 180 CKSSYB102K50
 C 182 CAPACITOR(CERAMIC) VCG1057
 C 183 CAPACITOR(CERAMIC) VCG1057
 C 184 CAPACITOR(CERAMIC) VCG1057
 C 185 CKSSYF104Z16

C 186 CAPACITOR(CERAMIC) VCG1057
 C 187 CAPACITOR(CERAMIC) VCG1057
 C 188 CAPACITOR(CERAMIC) VCG1057
 C 189 CAPACITOR(CERAMIC) VCG1057
 C 191 CAPACITOR(CERAMIC) VCG1057

C 192 CAPACITOR(CERAMIC) VCG1057
 C 193 CAPACITOR(CERAMIC) VCG1057
 C 194 CAPACITOR(CERAMIC) VCG1057
 C 195 CAPACITOR(CERAMIC) VCG1057
 C 196 CAPACITOR(CERAMIC) VCG1057

C 197 CKSRYF104Z25
 C 198 CAPACITOR(CERAMIC) VCG1057
 C 199 CAPACITOR(CERAMIC) VCG1057
 C 200 CAPACITOR(CERAMIC) VCG1057
 C 201 CAPACITOR(CERAMIC) VCG1057

C 202 CAPACITOR(CERAMIC) VCG1057
 C 203 CKSSYB102K50
 C 204 CAPACITOR(CERAMIC) VCG1057
 C 205 CKSSYB102K50
 C 206 CHIP ELECT.CAPACITOR CEVW221M4

C 207 CAPACITOR(CERAMIC) VCG1057
 C 208 CAPACITOR(CERAMIC) VCG1057
 C 209 CAPACITOR(CERAMIC) VCG1057
 C 210 CAPACITOR(CERAMIC) VCG1057
 C 211 CAPACITOR(CERAMIC) VCG1057

C 212 CAPACITOR(CERAMIC) VCG1057
 C 214 CAPACITOR(CERAMIC) VCG1057
 C 215 CHIP ELECT.CAPACITOR GEVW221M4
 C 216 CAPACITOR(CERAMIC) VCG1057
 C 217 CAPACITOR(CERAMIC) VCG1057

C 218 CCSRCH100D50
 C 219 CCSRCH100D50
 C 220 CAPACITOR(CERAMIC) VCG1057
 C 221 CAPACITOR(CERAMIC) VCG1057
 C 222 CAPACITOR(CERAMIC) VCG1057

C 223 CAPACITOR(CERAMIC) VCG1057
 C 224 CAPACITOR(CERAMIC) VCG1057
 C 225 CAPACITOR(CERAMIC) VCG1057
 C 226 CKSSYF104Z16
 C 228 CAPACITOR(CERAMIC) VCG1057

C 232 DCH1201
 C 233 CKSSYB102K50
 C 234 CEVW101M16
 C 235 CKSSYB102K50
 C 236 CKSSYB102K50

C 237 CKSSYF104Z16
 C 238 CKSSYF104Z16
 C 239 CKSSYB102K50
 C 240 CKSSYB102K50
 C 241 CKSSYF104Z16

C 242 CKSSYF103Z50
 C 243 CKSSYB102K50
 C 244 CKSSYF104Z16
 C 245 CKSSYF104Z16
 C 246 CKSSYB102K50

C 247 CKSSYB102K50
 C 248 CHIP ELECT.CAPACITOR CEVW221M4
 C 249 CKSSYF104Z16
 C 250 CKSSYB102K50
 C 251 CKSSYB102K50

C 252 CKSSYF104Z16
 C 253 CKSSYF104Z16
 C 254 CKSSYF104Z16

F SERVICE DVUB ASSY (DVR-LX60) MISCELLANEOUS

L 904 (B,217,25) CHIP FERRITE BEADS VTL1169
 L 905 (B,219,7) CHIP FERRITE BEADS VTL1169
 L 907 (B,219,31) CHIP FERRITE BEADS VTL1169
 L 908 (B,217,31) CHIP FERRITE BEADS VTL1169
 JA 901 (A,204,59) 1394-TERMINAL VKN2028
 JA 902 (A,203,15) USB CONNECTOR VKB1226
 JA 903 (A,219,37) USB CONNECTOR VKB1227

RESISTORS

R 901 (B,222,52) RS1/16S0R0J
 R 902 (B,222,55) RS1/16S0R0J
 R 903 (B,222,63) RS1/16S0R0J
 R 904 (B,222,67) RS1/16S0R0J
 R 905 (B,225,21) RS1/16S330J
 R 906 (B,225,17) RS1/16S330J
 R 907 (B,222,40) RS1/16S330J
 R 908 (A,226,57) RS1/16S0R0J
 R 909 (B,222,43) RS1/16S330J
 R 912 (A,227,69) RS1/16S0R0J

CAPACITORS

C 905 (A,227,29) CKSRYF105Z10
 C 906 (A,227,32) CKSRYF105Z10
 C 907 (B,216,49) CKSRYF104Z25
 C 908 (B,212,67) CKSRYF104Z25

F SERVICE DVUB ASSY (DVR-550H-S, -AV) MISCELLANEOUS

JA 901 (A,204,59) 1394-TERMINAL VKN2028
 CN901 (A,231,57) CONNECTOR VKN1932

RESISTORS

R 901 (B,222,52) RS1/16S0R0J
 R 902 (B,222,55) RS1/16S0R0J
 R 903 (B,222,63) RS1/16S0R0J
 R 904 (B,222,67) RS1/16S0R0J
 R 908 (A,226,57) RS1/16S0R0J
 R 912 (A,227,69) RS1/16S0R0J

CAPACITORS

C 907 (B,216,49) CKSRYF104Z25
 C 908 (B,212,67) CKSRYF104Z25

G POWER SUPPLY ASSY

POWER SUPPLY ASSY has no service part.

13. IC INFORMATION

• The information shown in the list is basic information and may not correspond exactly to that shown in the schematic diagrams.

■ PMC020A8 (SERVICE TUSB ASSY : IC101)

• TUNER Microcomputer

● Pin Function

No.	Mark	Pin Name	I/O	Pin Function
1	PA3/SO8	NC	O	Not used
2	PA4/SI8/SB8	NC	O	Not used
3	PA5/SCK8	NC	O	Not used
4	P70/INT0/T0LCP	WDT	I	WDT for microcomputer runaway detection RC is external connection. H: Forced reset
5	P71/INT1/T0HCP	ACDET	I	Existence detection of AC power Level interrupt
6	P72/INT2/T0IN/T0LCP	HS_MTOT	I	System controller communication handshake From system controller to Tuner controller
7	P73/INT3/T0IN/T0HCP	IR	I	Pulse input of the remote control unit
8	RES#	XTRESET	I	Reset input
9	XT1	XT1	I	Sub clock connection 32.768kHz
10	XT2	XT2	O	Sub clock connection
11	VSS1	GND	-	Ground
12	CF1	CF1	I	Main clock connection 15MHz
13	CF2	CF2	O	Main clock connection
14	VDD1	VDD1	-	Power supply
15	P80/AN0	MODEL1	AI	Input 1 for destination judgment
16	P81/AN1	MODEL2	AI	Input 2 for destination judgment
17	P82/AN2	KEY1	AI	Main unit key input 1
18	P83/AN3	KEY2	AI	Main unit key input 2
19	P84/AN4	KEY3	AI	Main unit key input 3
20	P85/AN5	AGC	AI	AGC voltage input from the tuner
21	P86/AN6	BATTERY	AI	Input for battery voltage check It is not used but pull-up is necessary.
22	P87/AN7	FUNC	AI	SCART Function signal input
23	P10/SO0	SDET3	I	Plug detection of S terminal 3
24	P11/SI0/SB0	SDET2	I	Plug detection of S terminal 2
25	P12/SCK0	SDET1	I	Plug detection of S terminal 1
26	P13/SO1	AVLOUT	O	AV.Link output signal Negative logic Reverse on the SCART terminal
27	P14/SI1/SB1	SDA	O/D	IIC communication (data)
28	P15/SCK1	SCL	O/D	IIC communication (clock)
29	P16/T1PWML	XSYSRST	O	IC reset signal of whole system
30	P17/T1PWHM/BUZ	NC	O	Not used
31	PE0/AN12	AFT	AI	AFT voltage input
32	PE1/AN13	NC	O	Not used
33	PE2/AN14	XAMUTE2	O	Audio mute signal of output stage Negative logic H: Release, L: Mute
34	PE3/AN15	SEL_R	O	Switching external video SW of Red/Chroma
35	PE4	SEL_L3	O	Switching external video SW of S terminal 3 input
36	PE5	NC	O	Not used
37	PE6	DDCSW1	O	DDC/IIC switching control Select the MAIN or TUJB
38	PE7	DDCSW2	O	DDC/IIC switching control H: OFF L: ON
39	VSS4	GND	-	Ground
40	VDD4	VDD4	-	Power supply
41	PF0	FUNC_ON	O	Function output signal
42	PF1	SQU	O	Squeeze output superimposed signal
43	PF2	CAPACITOR	I	Electric discharge detection of capacitor for power supply backup
44	PF3	NC	O	Not used
45	PF4/IRP	IROUT	O	Pulse output for IR blaster
46	PF5	PSAVE	O	Power save mode switch of HA118326
47	PF6	XSCMUTE	O	Audio mute control of SCART
48	PF7	AVLTH	O	Through switch of AV.Link communication line
49	SI2P0/SO2	FLDATA	O	Communication line with FL driver From tuner controller to FL driver
50	SI2P1/SI2/SB2	FLSTB	O	Communication strobe signal with FL driver
51	SI2P2/SCK2	FLCLK	O	Communication clock with FL driver
52	SI2P3/SCK20	RFTHRU	O	RF through switch of the tuner Control with the main unit setting during standby.
53	PWM1	NC	O	Not used

No.	Mark	Pin Name	I/O	Pin Function
54	PWM0	FANCTRL	O	Radiation of heat fan rotating speed control H: Top speed, L: Stop Intermediate speed realizes by PWM
55	VDD2	VDD2	-	Power supply
56	VSS2	GND	-	Ground
57	P00	P_CONT2	O	Power supply control of the main board For controlling 2.5V and 3.3V
58	P01	MUTECTL	O	Mute invalidity control Port to suppress last stage mute
59	P02	EPGEQ	O	Equalizer switch of slicer input video
60	P03	TUON	O	Power supply control of the tuner section There is a case to turn on the power during standby independently.
61	P04	SWVION1	O	AV selector power supply
62	P05/CKO	P_CONT	O	Power supply control of the whole system
63	P06/T6O	FLPON	O	Power supply control of the FL tube
64	P07/T7O	SWVION	O	Power supply control of video system
65	P20/INT4/T1IN/T0LCP/T0HCP/INT6/T0LCP1/SSGI0	MRST	I	Main board power failure detection Edge interrupt
66	P21/INT4/T1IN/T0LCP/T0HCP	NC (IN)	I	Not used
67	P22/INT4/T1IN/T0LCP/T0HCP/HCTR	CSYNCIN	I	C-Sync for Auto Start Recording (Not used)
68	P23/INT4/T1IN/T0LCP/T0HCP	XCHECKER	I	Unit checker mounting distinction
69	P24/INT5/T1IN/T0LCP/T0HCP/INT7/T0HCP1/SSGI	CEC	O/D	Communication line of HDMI CEC
70	P25/INT5/T1IN/T0LCP/T0HCP	AVLIN	I	AV.Link input line
71	P26/INT5/T1IN/T0LCP/T0HCP	MSPSTAT	I	Multiplex status change detection of MSP D_CTR_I/O_1
72	P27/INT5/T1IN/T0LCP/T0HCP	BLANKIN	I	BLANK signal input of the SCART
73	P30/PWM4	HOTPLUG	I	HPD signal input of HDMI
74	P31/PWM5	TU_DCCON	O	DC/DC converter For +32V generation
75	P32/UTX1	TXD1	O	Transmission for RS-232C terminal
76	P33/URX1	RXD1	I	Reception for RS-232C terminal
77	P34/UTX2	TXD2	O	UART2 transmission Not used.
78	P35/URX2	RXD2	O	UART2 reception Not used.
79	P36	HS_TTOM	O	System controller communication handshake From tuner controller to system controller
80	VDDODA	VDDODA	-	Power supply
81	PB6/CVD/CSYNC	CVBSIN	I	Input video for data slicer 1.0Vpp
82	VSSVCO	GND	-	Ground
83	PB4/FILTSLC	FILTSLC	I	External filter for slicer PLL
84	VDDVCO	VDDVCO	-	Power supply
85	PB2	DTBON	O	Power supply control for DTB
86	PB1	ANT5V_SW	O	Power supply control for DVB-T antenna
87	PB0/DS1FLD	DET_ANT	I	Short-circuit detection of power supply for DVB-T antenna
88	VSS3	GND	-	Ground
89	VDD3	VDD3	-	Power supply
90	PC7/DBGP2	DBGP2	O/D	Control port for on-chip debugger
91	PC6/DBGP1	DBGP1	O/D	Control port for on-chip debugger
92	PC5/DBGP0	DBGP0	O/D	Control port for on-chip debugger
93	PC4/AN11	LED_DIVX	O	Indicator LED
94	PC3/AN10	LED_PLTV	O	Indicator LED
95	PC2/AN9	LED_D_TV	O	Indicator LED
96	PC1/AN8	LED_A_TV	O	Indicator LED
97	PC0/OCSYNC	NC	O	Not used
98	PA0/SO7	SD_TTOM	O	System controller communication data line. From tuner controller to system controller
99	PA1/SI7/SB7	SD_MTOT	I	System controller communication data line. From system controller to tuner controller
100	PA2/SCK7	SCK_MTOT	I	System controller communication clock. From system controller to tuner controller