

Service Manual

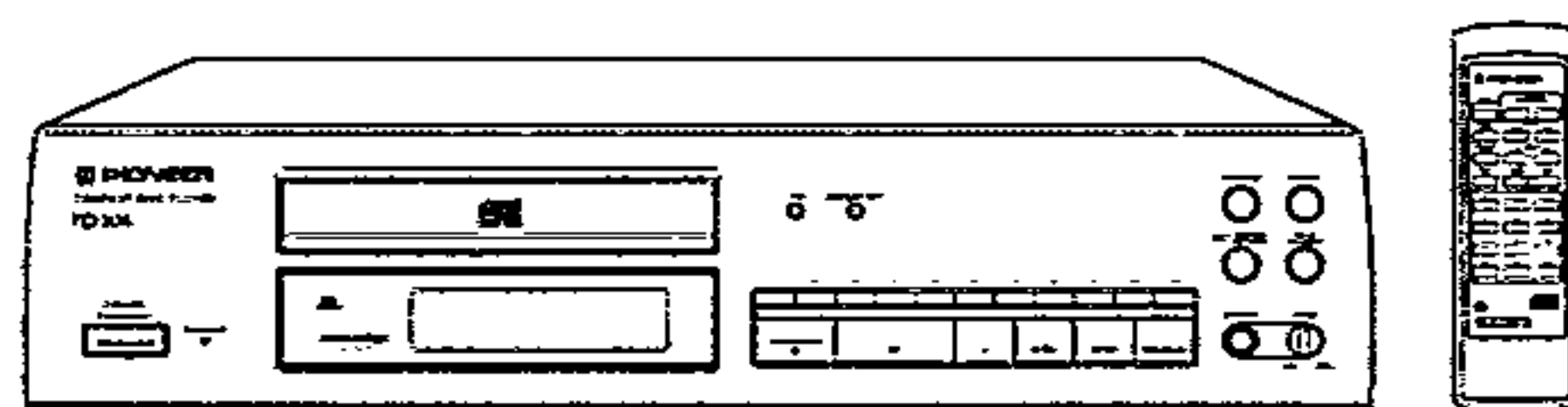

ORDER NO.
RRV1324

COMPACT DISC PLAYER

PD-204

PD-104

PD-004

THIS MANUAL IS APPLICABLE TO THE FOLLOWING MODEL(S) AND TYPE(S).

Type	Model			Power Requirement	The voltage can be converted by the following method.
	PD-204	PD-104	PD-004		
WEMXK	○	○	—	AC220 – 240V	
WBWXK	○	○	—	AC220 – 240V	
WPWXJ	○	○	—	AC220 – 240V	
WLXJ	○	○	—	AC220 – 240V	
RDXJ	○	○	—	AC110 – 127V/220 – 240V	With the voltage selector
WEXK/FR	—	—	○	AC220 – 240V	

CONTENTS

1. SAFETY INFORMATION	2
2. EXPLODED VIEWS, PACKING AND PARTS LIST ..	3
3. SCHEMATIC AND PCB CONNECTION DIAGRAM	9
4. PCB PARTS LIST	18
5. ADJUSTMENTS	20
6. IC INFORMATION	29
7. BLOCK DIAGRAM	31
8. CONTRAST OF MECELLANEOUS PARTS	32
9. PANEL FACILITIES	36
10. SPECIFICATIONS	36

PIONEER ELECTRONIC CORPORATION 4-1, Meguro 1-Chome, Meguro-ku, Tokyo 153, Japan

PIONEER ELECTRONICS SERVICE INC. P.O. Box 1760, Long Beach, California 90801 U.S.A.

PIONEER ELECTRONICS OF CANADA, INC. 300 Allstate Parkway Markham, Ontario L3R 0P2 Canada

PIONEER ELECTRONIC [EUROPE] N.V. Haven 1087 Keetberglaan 1, 9120 Melsele, Belgium

PIONEER ELECTRONICS AUSTRALIA PTY. LTD. 178-184 Boundary Road, Braeside, Victoria 3195, Australia TEL : [03] 580-9911

© **PIONEER ELECTRONIC CORPORATION 1995**

1. SAFETY INFORMATION

(FOR EUROPEAN MODEL ONLY)

VARO!
AVATTAESSA JA SUOJALUKITUS OHITETTAESSA OLET ALTTIINA NÄKYMÄTTÖMÄLLE LASERSÄTEILYLLE. ÄLÄ KATSO SÄTEESEEN.



LASER
Kuva 1
Lasersäteilyn varoitusmerkki

WARNING!
DEVICE INCLUDES LASER DIODE WHICH EMITS INVISIBLE INFRARED RADIATION WHICH IS DANGEROUS TO EYES. THERE IS A WARNING SIGN ACCORDING TO PICTURE 1 INSIDE THE DEVICE CLOSE TO THE LASER DIODE.



LASER
Picture 1
Warning sign for laser radiation

ADVERSEL:
USYNLIG LASERSTRÅLING VED ÅBNING NÅR SIKKERHEDSAFBRYDERE ER UDE AF FUNKTION UNDGÅ UDSÆTTELSE FOR STRÅLING.

IMPORTANT
THIS PIONEER APPARATUS CONTAINS LASER OF CLASS 1. SERVICING OPERATION OF THE APPARATUS SHOULD BE DONE BY A SPECIALLY INSTRUCTED PERSON.

VARNING!
OSYNLIG LASERSTRÅLNING NÅR DENNA DEL ÄR ÖPPNAD OCH SPÄRREN ÄR URKOPPLAD. BETRAKTA EJ STRÅLEN.

LASER DIODE CHARACTERISTICS
MAXIMUM OUTPUT POWER: 5 mw
WAVELENGTH: 780-785 nm

LABEL CHECK

WBWXK, WPWXJ and WLXJ types

WEMXK, WBWXK, WLXJ and WEXK/FR types

WEMXK and WEXK/FR types

CAUTION
INVISIBLE LASER RADIATION WHEN OPEN, AVOID EXPOSURE TO BEAM
PRW1018



ADVARSEL
USYNLIG LASERSTRÅLING VED ÅBNING NÅR SIKKERHEDSAFBRYDERE ER UDE AF FUNKTION. UNOGÅ UDSÆTTELSE FOR STRÅLING.
VORSICHT!
UNSIHTBARE LASERSTRÅLUNG TRIT AUS, WENN DECKEL (ODER KLAPPE) GEÖFFNET IST! NICHT DEM STRAHL AUSSETZEN!
VRW1094

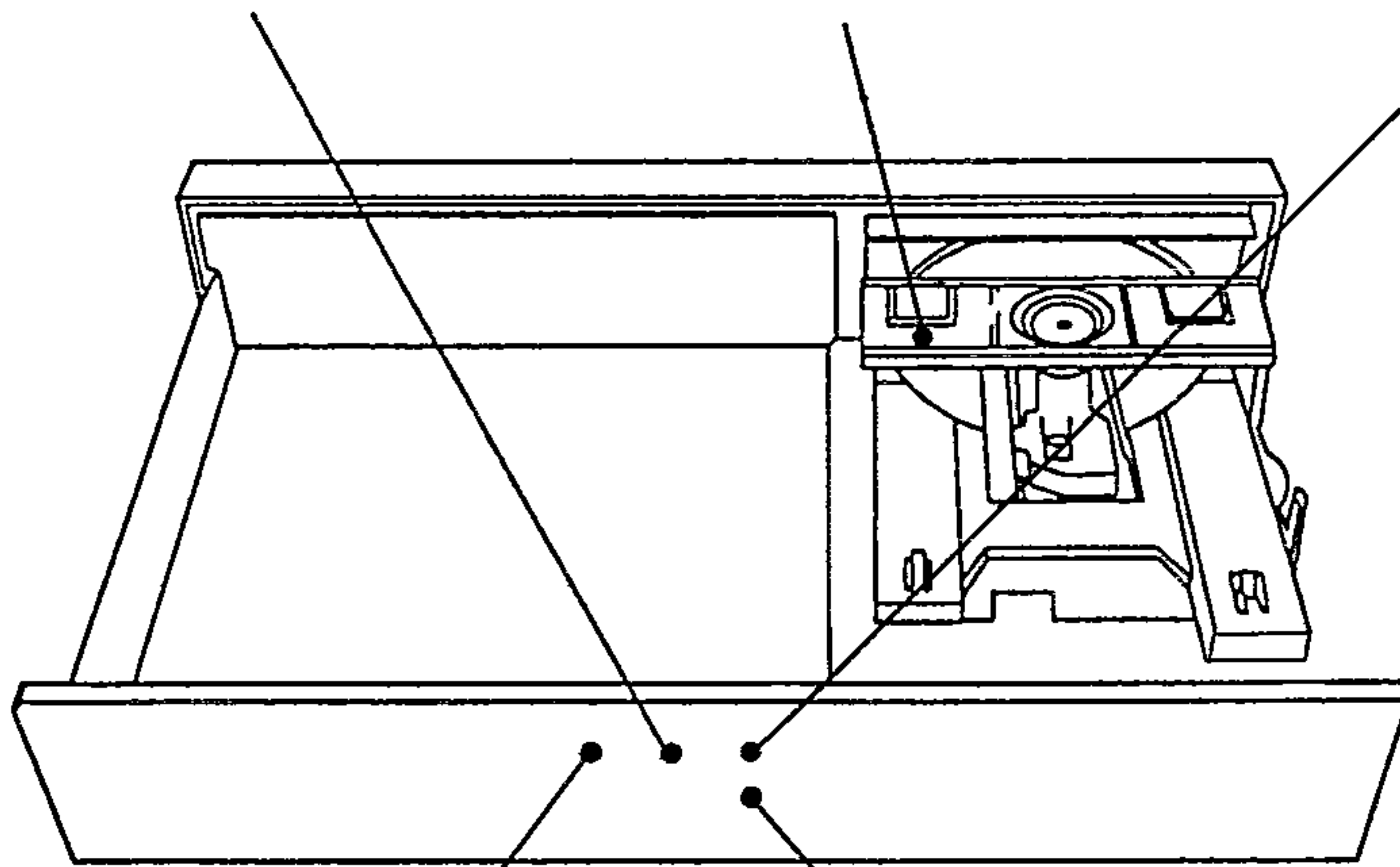

Additional Laser Caution

- Laser Interlock Mechanism**
The position of the switch (S601) for detecting loading state is detected by the system microprocessor, and the design prevents laser diode oscillation when the switch (S601) is not CLMP terminal side (when CLMP signal is OFF or high level). Thus, the interlock will no longer function if the switch (S601) is deliberately set to CLMP terminal side (low level).
The interlock also does not function in the test mode *. Laser diode oscillation will continue, if pin 1 of M51593FP (IC101) on the PRE AMP BOARD ASSY mounted on the pickup assembly is connected to GND, or pin 19 is connected to low level (ON), or else the terminals of Q101 are shorted to each other (fault condition).
- When the cover is opened, close viewing of the objective lens with the naked eye will cause exposure to a Class 1 laser beam.
92S1B

* Refer to page 21.

CLASS 1 LASER PRODUCT
VRW-328

WEMXK, WBWXK, WLXJ and WEXK/FR types

VARO!
Avattaessa ja suojalukitus ohitettaessa olet alttiina näkymättömälle lasersäteilylle. Älä katso säteeseen.
VARNING!
Osynlig laserstrålning när denna del är öppnad och spärren är urkopplad. Beträkta ej strålen.
PRW1233

WEMXK and WEXK/FR types

2. EXPLODED VIEWS, PACKING AND PARTS LIST

- NOTES:**
- Parts marked by “NSP” are generally unavailable because they are not in our Master Spare Parts List.
 - The Δ mark found on some component parts indicates the importance of the safety factor of the parts. Therefore, when replacing, be sure to use parts of identical designation.
 - Parts marked by “ \odot ” are not always kept in stock. Their delivery time may be longer than usual or they may be unavailable.

2.1 PACKING

Parts List

Mark	No.	Description	Parts No.
	1	Cord with pin plug	PDE1248
	2	Operating instructions (English)	PRB1223
	3	Operating instructions (German/French/Italian/Dutch/Swedish/Spanish/Portuguese)	PRE1212
	4	Remote control unit	PWW1061
	5	Battery cover	PZN1010
NSP	6	Battery (R03, AAA)	VEM – 022
	7	Polyethylene bag	Z21 – 038
	8	Packing sheet	AHG1090
	9	Paper protector	PHA1297
	10	Paper spacer	PHA1298
	11	Packing case	PHG2153

● For WEMXK and WEXK/FR types

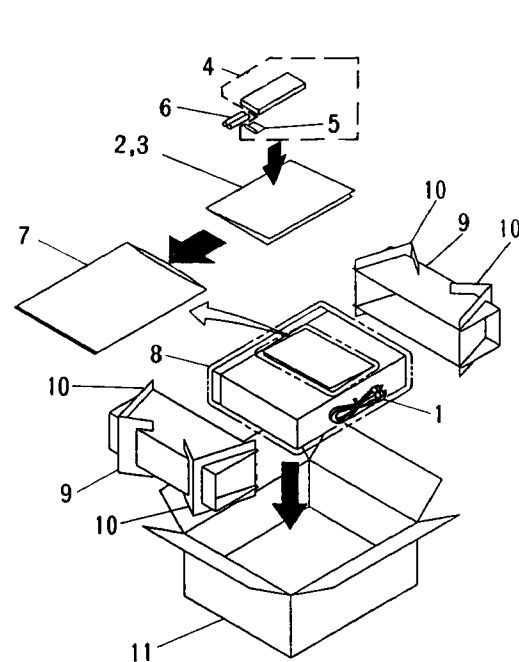

● For RDXJ, WPWXJ and WLXJ types

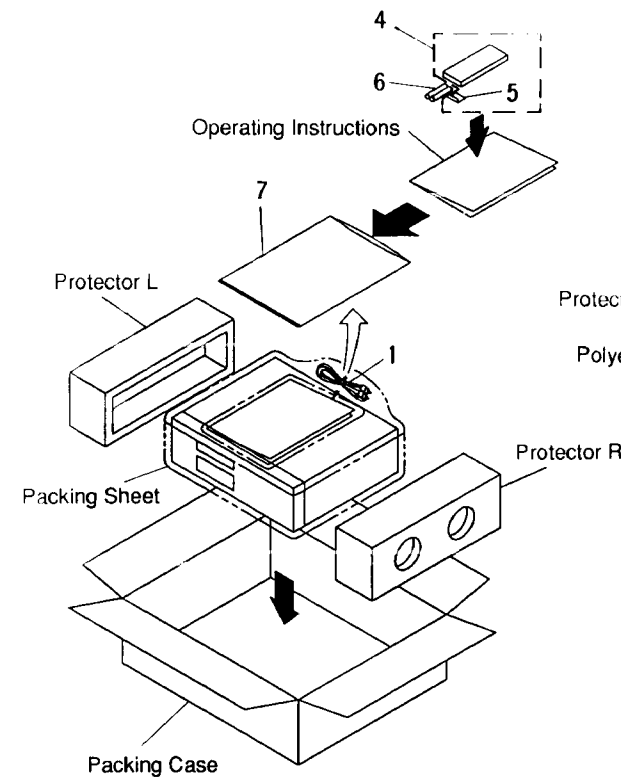

● For WBWXK type

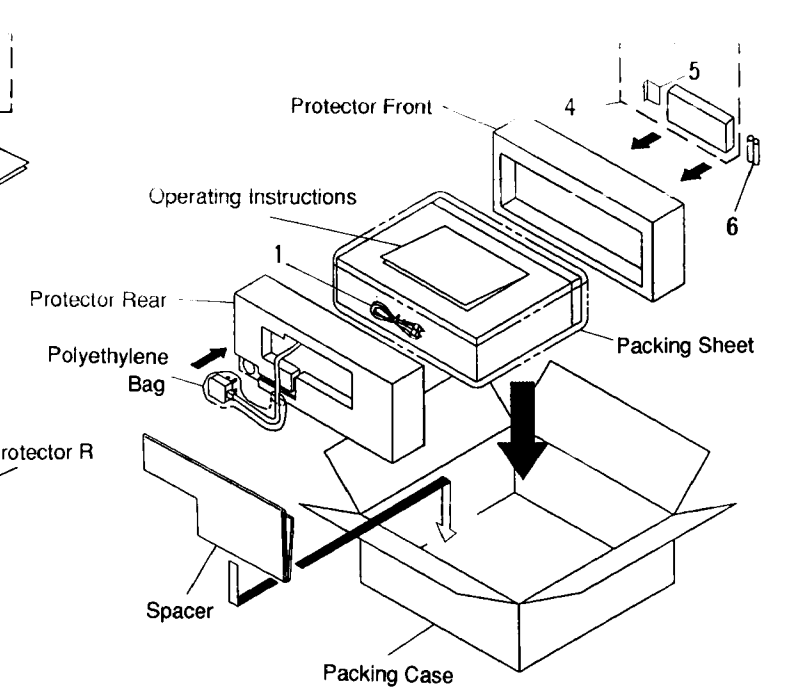

2.2 EXTERIOR

NOTE: Screws adjacent to ▼ mark on the product are used for disassembly.

Parts List

Mark	No.	Description	Parts No.
	1	Bonnet	RYY1183
	2	Screw	FBT40P080FZK
	3	Screw	BBZ30P080FZK
	4	Screw	BBZ30P160FMC
NSP	5	SINGLE MECHANISM ASSY	RXA1672
	6	Tray name plate	PNW2539
	7	PCB spacer	PNY - 404
	8	Insulator	PNW1912
Δ	9	Power transformer	PTT1236
	10	Screw	IBZ30P100FCC
	11	Screw	IBZ30P150FCC
Δ	12	Cord stopper	CM - 22B
Δ	13	AC power cord	PDG1003
Δ	14	Screw	BBZ30P060FMC
Δ	15	MOTHER BOARD ASSY	PWM1936
	16	HEADPHONE BOARD ASSY	PWZ2948
	17	Headphone knob	PAC1707
	18	Rear base	PNA2188
	19	Screw	IBZ30P080FCC
	20	Display window	PAM1665
	21	Name plate	PAM1608
	22	Function panel	PNW2546
NSP	23	Mode button	PAC1796
	24	Under base	PNA2219
	25	10 key	PAC1797
	26	Function button	PAC1798
	27	LED lens	PNW2019
	28	Power button	PAC1708
NSP	29	SW BOARD ASSY	PWZ2940
	30	Screw	PPZ30P100FMC
	31	FUNCTION BOARD ASSY	PWZ2933
	32	32P F.F.C/30V	PDD1041
	33	
	34	Screw	PDZ30P050FMC

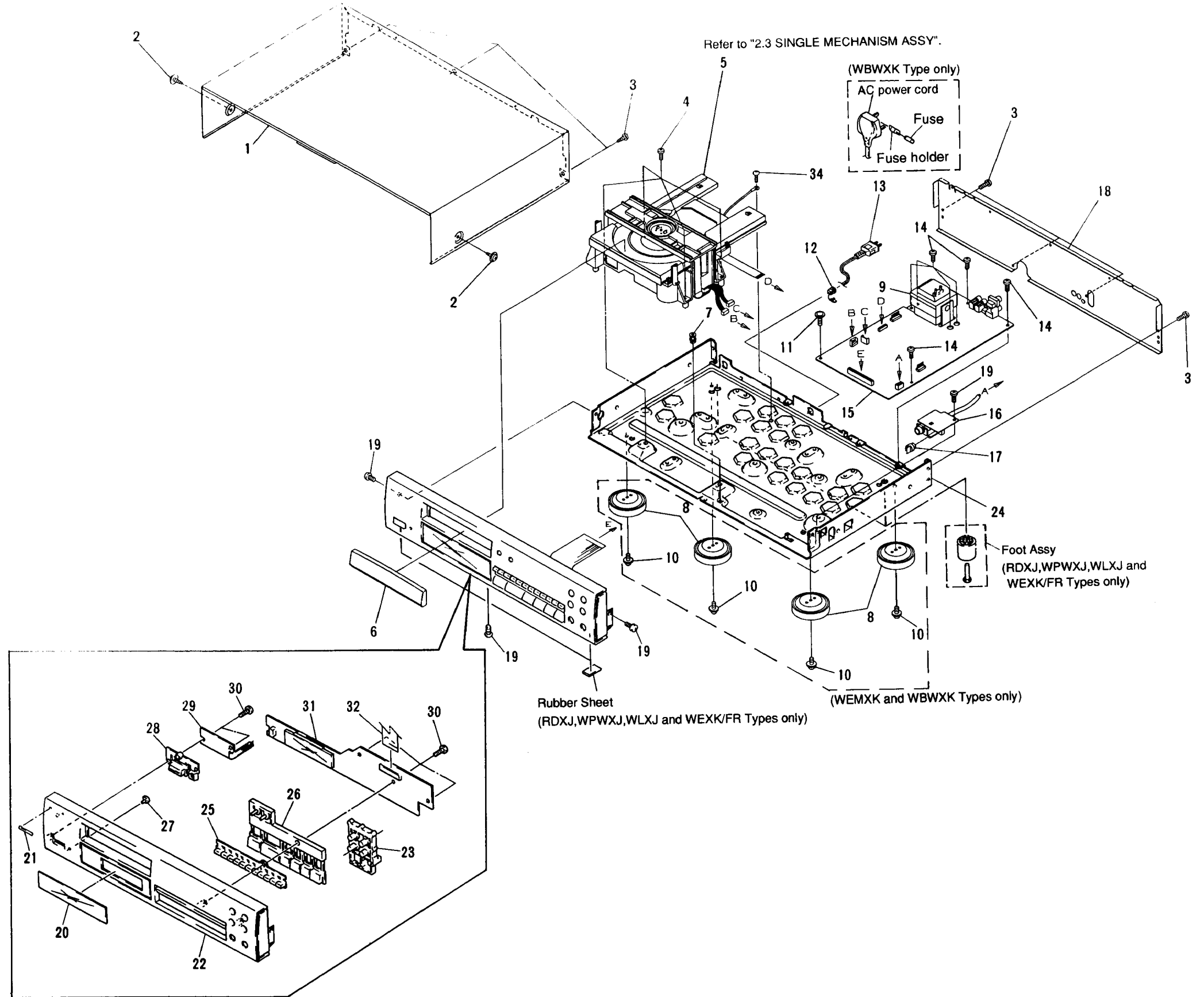

2.3 SINGLE MECHANISM ASSY

• FOR RXA1672

Parts List

Mark	No.	Description	Parts No.
	1	Lever switch (CLAMP)	DSK1003
	2	Float screw	PBA1048
	3	Rubber belt	PEB1193
	4	Motor pulley	PNW1634
	5	Tray	PNW2455
	6	Float base	PNW2032
	7	Drive gear 2	PNW2369
	8	Gear pulley	PNW2034
	9	Clamper base	PNW2375
	10	Clamp cam	PNW2364
	11	DC motor/0.75W	PXM1010
	12	Float rubber B	REB1287
	13	Float rubber G	REB1288
	14	Screw	BPZ26P080FMC
	15	Screw	Z39-019
	16	Screw	PMZ26P040FMC
	17	Pinion gear	PNW2055
NSP	18	DC motor (CARRIAGE)	PXM1027
	19	DC motor Assy (SPINDLE)	PEA1235
	20	Carriage base	PNW2445
	21	Disc table	PNW1608
	22	Screw	JFZ20P030FN1
	23	Screw	JFZ17P025FZK
	24	Gear 3	PNW2054
	25	Gear 2	PNW2053
	26	Washer	WT12D032D025
	27	Pickup assy	PEA1291
	28	Guide bar	PLA1094
	29	Gear 1	PNW2052
NSP	30	Gear stopper	PNB1303
	31	Screw	BPZ20P060FMC
	32	PWB holder	PNW2057
	33	Screw	BPZ20P100FMC
	34	Earth lead unit	PDF1104
	35	Screw	BBZ26P060FMC
NSP	36	MECHANISM BOARD ASSY	PWX1192
	37	Clamp magnet	PMF1014
NSP	38	Yoke	PNB1216
	39	H spacer	PEB1249
	40	Clamper S	PNW1609
	41	Loading base	PNW2376
NSP	42	DC motor assy (CARRIAGE)	PEA1246
	43	SERVO MECHANISM ASSY	AXA7017
	44
	45	Connector assy (4P)	RDE1043
	46	Connector assy (5P)	PDE1239

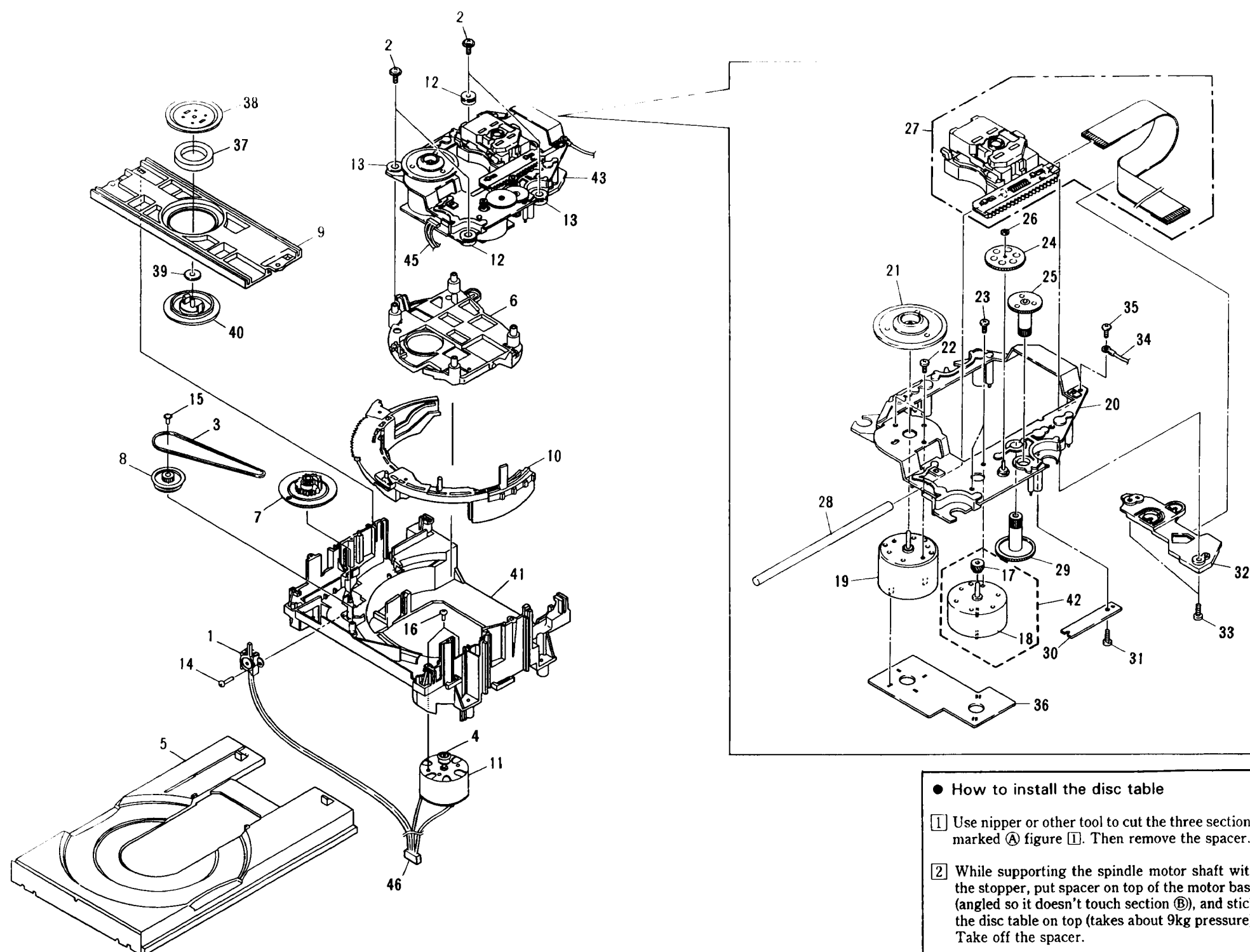

3. SCHEMATIC AND PCB CONNECTION DIAGRAM

NOTE FOR SCHEMATIC DIAGRAMS (Type 4A)

1. When ordering service parts, be sure to refer to "PARTS LIST OF EXPLODED VIEWS" or "PCB PARTS LIST".

2. Since these are basic circuits, some parts of them or the values of some components may be changed for improvement.

3. RESISTORS:
Unit: k: kΩ, M: MΩ, or Ω unless otherwise noted.
Rated power: 1/4W, 1/6W, 1/8W, 1/10W unless otherwise noted.
Tolerance: (F): ±1%, (G): ±2%, (K): ±10%, (M): ±20% or ±5% unless otherwise noted.

4. CAPACITORS:
Unit: p: pF or μF unless otherwise noted.
Ratings: capacitor (μF)/ voltage (V) unless otherwise noted.
Rated voltage: 50V except for electrolytic capacitors.

5. COILS:
Unit: m: mH or μH unless otherwise noted.

6. VOLTAGE AND CURRENT:
□ or - V : DC voltage (V) in PLAY mode unless otherwise noted.
◇ mA or - mA : DC current in PLAY mode unless otherwise noted.
Value in () is DC current in STOP mode.

7. OTHERS:
• ⊙ or ⊚ : Adjusting point.
• ⊠ : Measurement point.
• The Δ mark found on some component parts indicates the importance of the safety factor of the parts. Therefore, when replacing, be sure to use parts of identical designation.

8. SCH-□ ON THE SCHEMATIC DIAGRAM:
• SCH-□ indicates the drawing number of the schematic diagram. (SCH stands for schematic diagram.)

9. SWITCHES (Underline indicates switch position):

- FUNCTION BOARD ASSY
- S701 : ▲ OPEN/CLOSE
 - S702 : ■ STOP
 - S705 : RANDOM
 - S706 : PEAK SEARCH
 - S708 : TIME
 - S710 : PROGRAM
 - S711 : DISPLAY OFF
 - S713 : REPEAT
 - S714 : EDIT
 - S715 : 5
 - S716 : 10
 - S717 : 1
 - S718 : 2
 - S719 : 3
 - S720 : 4
 - S721 : 6
 - S722 : 7
 - S723 : 8
 - S724 : 9
 - S725 : ►/◄ PLAY/PAUSE
 - S726 : ◄◄/►► TRACK/MANUAL SEARCH REV
 - S727 : ►►/◄◄ TRACK/MANUAL SEARCH FWD
 - S728 : > 10

- SWITCH BOARD ASSY
- S801 : POWER STANDBY/ON

A

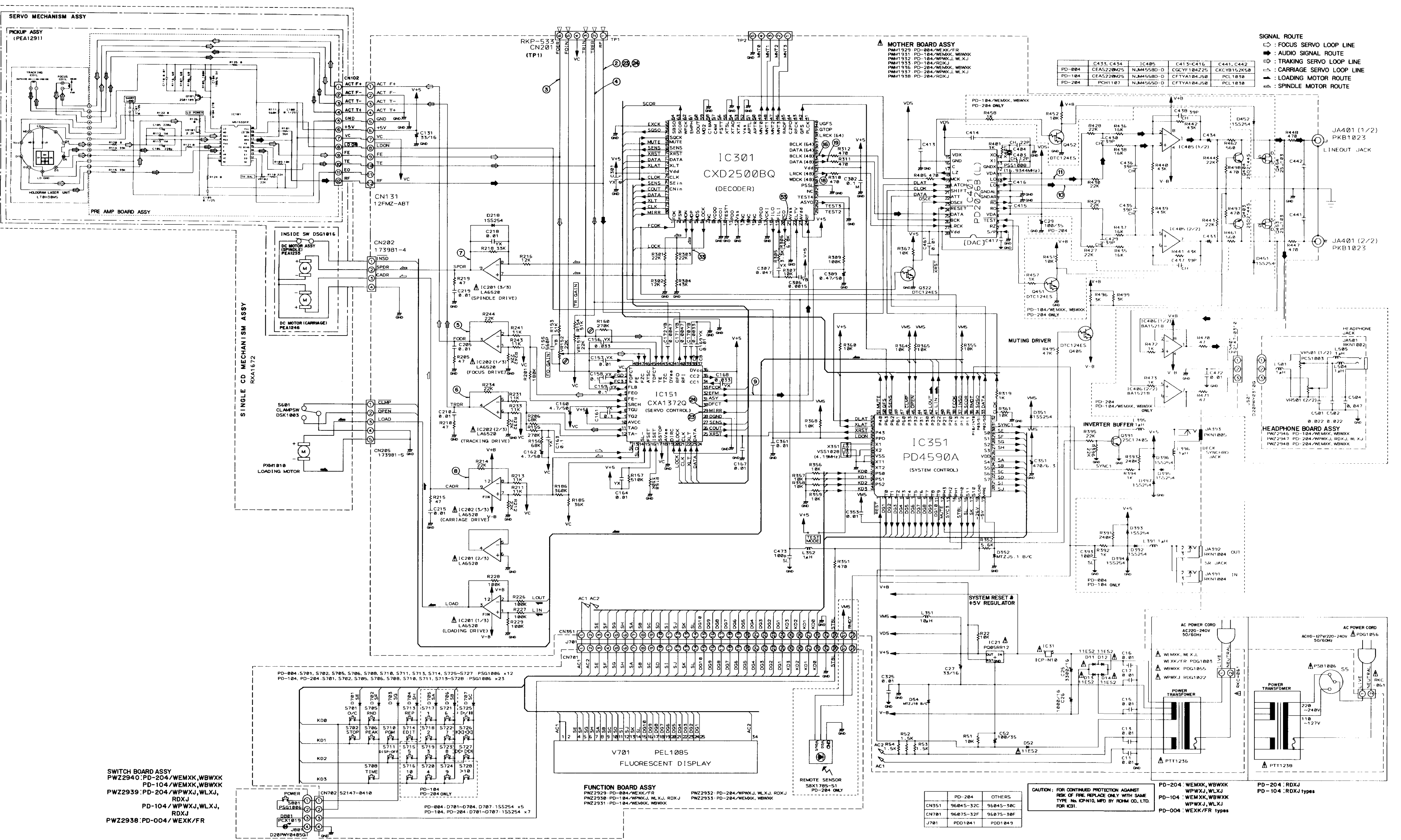

D

E

F

● This diagram is viewed from the mounted parts side.

NOTE FOR PCB DIAGRAMS:
 1. Part numbers in PCB diagrams match those in the schematic diagrams.
 2. A comparison between the main parts of PCB and schematic diagrams is shown below.

Symbol in PCB Diagrams	Symbol in Schematic Diagrams	Part Name
		Transistor
		Transistor with resistor
		Field effect transistor
		Resistor array
		3-terminal regulator

• The parts mounted on this PCB include all necessary parts for several destinations. For further information for respective destinations, be sure to check with the schematic diagram.

SWITCH BOARD ASSY

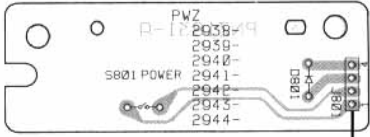

FUNCTION BOARD ASSY

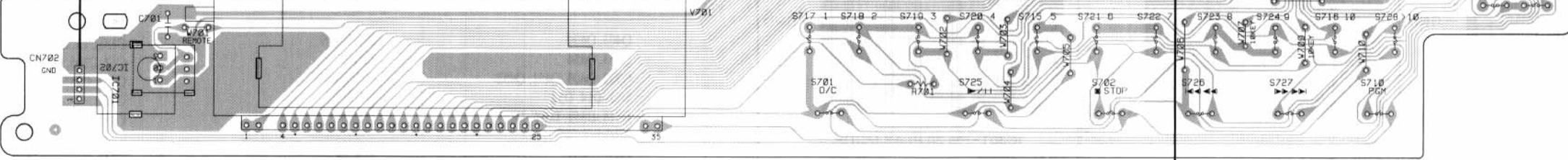

MECHANISM BOARD ASSY

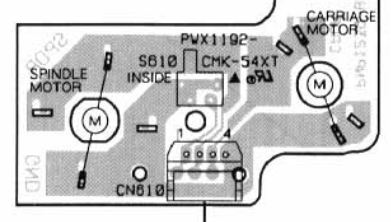

HEADPHONE BOARD ASSY

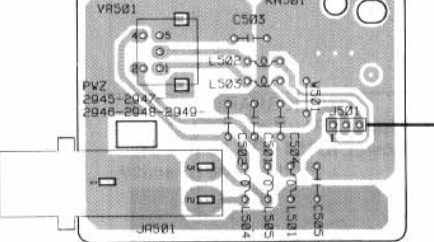

MOTHER BOARD ASSY

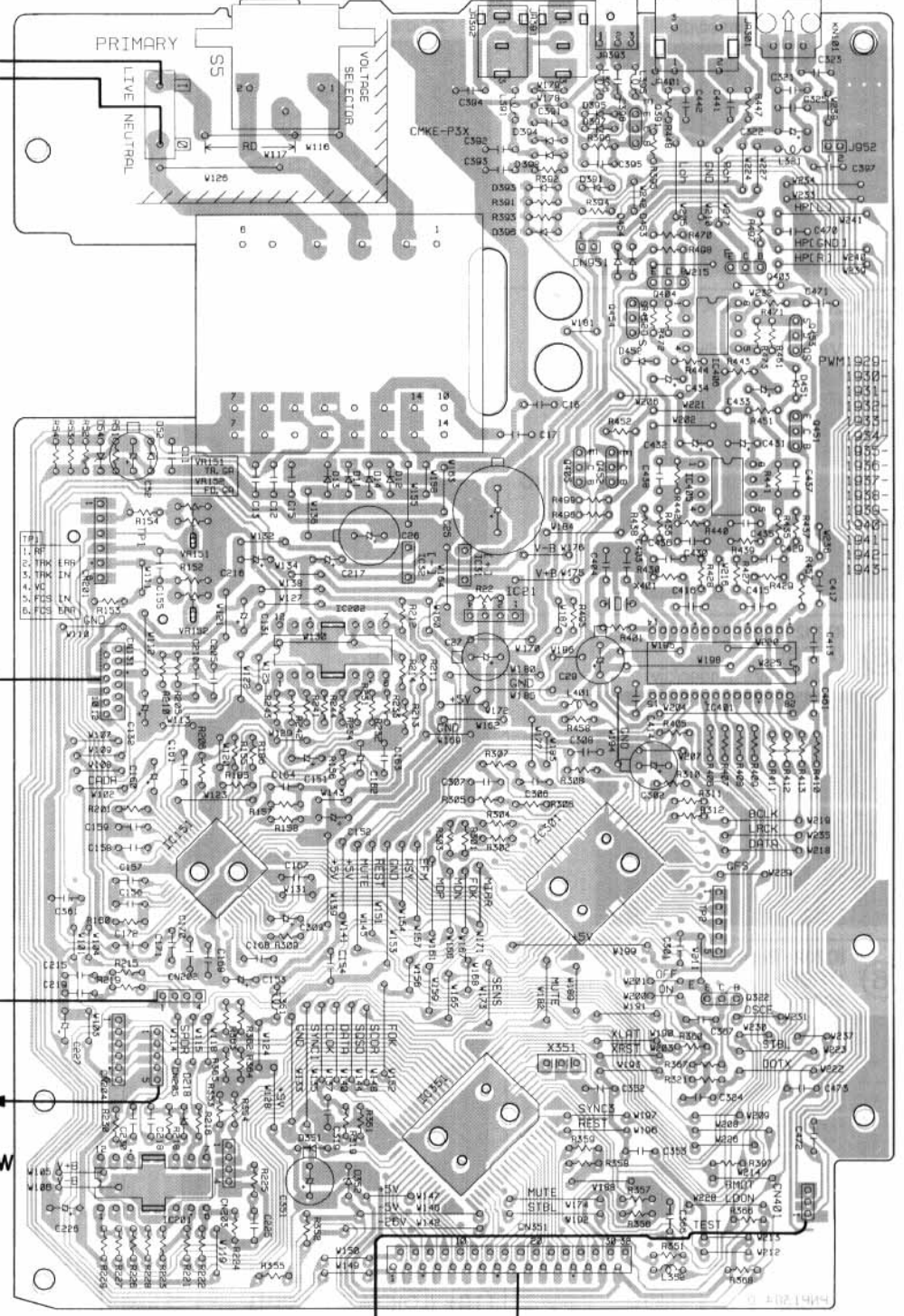

AC POWER CORD
 WEMXK, WBWXK, WPWXJ
 WLXJ, WEXK / FR :
 AC 220-240V/50/60Hz
 RDXJ :
 AC 110-127V/220-240V
 50/60Hz

PNP1387-A : PD-204 / WEMXK, WBWXK
 PD-104 / WEMXK, WBWXK
 PD-004 / WEXK / FR
 PNP1386-A : PD-204 / WPWXJ, WLXJ, RDXJ
 PD-104 / WPWXJ, WLXJ, RDXJ

PNP1384-B : PD-204 / WEMXK, WBWXK
 PD-104 / WEMXK, WBWXK
 PD-004 / WEXK / FR
 PNP1385-B : PD-204 / WPWXJ, WLXJ, RDXJ
 PD-104 / WPWXJ, WLXJ, RDXJ

- Q391
- Q403
- Q454
- Q404 IC406
- Q453
- Q451
- Q405 Q452
- IC405
- IC31
- IC21
- IC202 IC401
- IC151 IC301
- Q322
- IC351
- IC201

Mark	No.	Description	Parts No.
	CN401	JUMPER CONNECTOR (3P)	52147-0310
	CN351	FFC CONNECTOR (32P)	9604S-32C
	JA401	2P PIN JACK	PKB1023
	JA393	MINI JACK	PKN1005
	X401	CRYSTAL RESONATOR (16.9344MHz)	PSS1008

△		TERMINAL	RKC-061
	CN201	CONNECTOR (6P)	RKP-533
	X351	CERAMIC RESONATOR (4.19MHz)	VSS1028

FUNCTION BOARD ASSY

SEMICONDUCTORS

D701-D707 1SS254

SWITCHES AND RELAYS

S701, S702, S705, S706, S708 PSG1006
S710, S711, S713-S728 PSG1006

OTHERS

CN702 JUMPER CONNECTOR (4P) 52147-0410
CN701 FFC CONNECTOR(32P) 9607S-32F
V701 FL INDICATOR TUBE PEL1085
REMOTE SENSOR SBX1785-51

SWITCH BOARD ASSY

SEMICONDUCTORS

D801 PCX1019

SWITCHES AND RELAYS

S801 PSG1006

HEADPHONE BOARD ASSY

COILS AND FILTERS

L501, L504, L505 LAU010J

CAPACITORS

C501, C502 CKCYF223Z50
C504 CKCYF473Z50

RESISTORS

VR501 (5kΩ) PCS1003

OTHERS

JA501 HEADPHONE JACK RKN1002

MECHANISM BOARD ASSY

SWITCHES AND RELAYS

S610 DSG1016

OTHERS

CN610 MT CONNECTOR (4P) 173979-4

5. ADJUSTMENTS

● Adjustment Methods

If a disc player is adjusted incorrectly or inadequately, it may malfunction or not work at all even though there is nothing at all wrong with the pickup or the circuitry. Adjust correctly following the adjustment procedure.

● Adjustment Items/Verification Items and Order

If the specified values cannot be obtained or no adjustment is possible by performing the verifications or adjustments described in steps 1 – 4, the pickup block may be defective.

Step	Item	Test Point	Adjustment Location
1	Focus offset verification	TP1, Pin6 (FCS. ERR)	None
2	Tracking error balance verification	TP1, Pin2 (TRK. ERR)	None
3	Pickup radial/tangential direction tilt adjustment	TP1, Pin1 (RF)	Radial tilt adjustment screw. Tangential tilt adjustment screw
4	RF level verification	TP1, Pin1 (RF)	None
5	Focus servo loop gain adjustment	TP1, Pin5 (FCS. IN) TP1, Pin6 (FCS. ERR)	VR152 (FCS. GAN)
6	Tracking servo loop gain adjustment	TP1, Pin3 (TRK. IN) TP1, Pin2 (TRK. ERR)	VR151 (TRK. GAN)

● Abbreviation table

FCS. ERR	:Focus Error
TRK. ERR	:Tracking Error
FCS GAN	:Focus Gain
TRK GAN	:Tracking Gain
FCS. IN	:Focus In
TRK. IN	:Tracking In

● Measuring Instrument and Tools

1. Dual trace oscilloscope (10:1 probe)
2. Low-frequency oscillator
3. Test disc (YEDS - 7)
4. 8cm disc (With at least about 20 minutes of recording)
5. Low-pass filter (39kΩ + 0.001μF)
6. Resistor (100kΩ)
7. Ball point hexagon wrench (GGK1002)
8. Standard tools

● Test Point and Adjustment Variable Resistor Positions

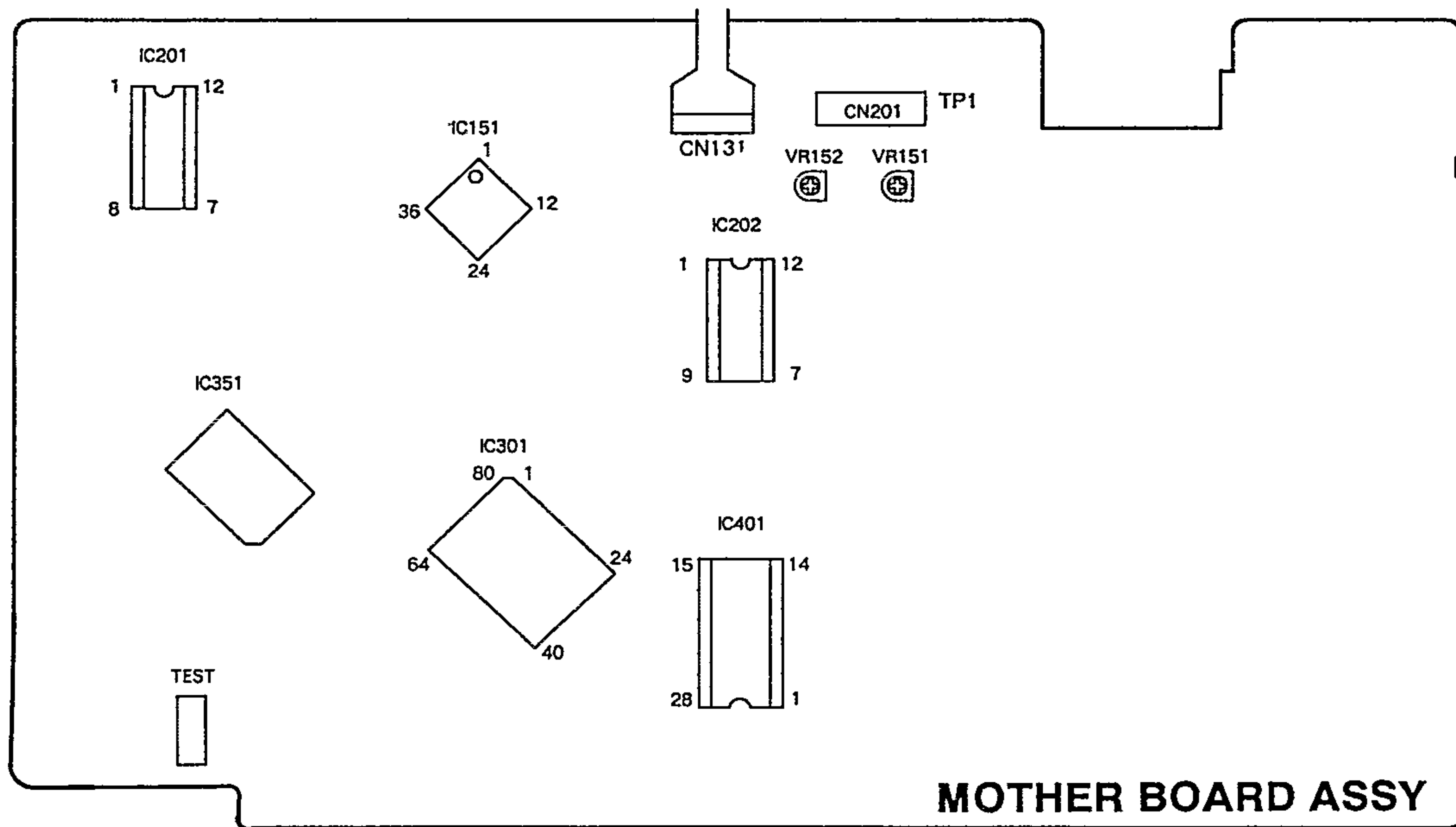

Fig. 1 Adjustment Locations

● Notes

1. Use a 10:1 probe for the oscilloscope.
2. All the knob positions (settings) for the oscilloscope in the adjustment procedures are for when a 10:1 probe is used.
3. GND of the oscilloscope connect to TP1, pin4 (VC). If GND is shorted to the ground of the player, the player should be damaged.

● Test Mode

These models have a test mode so that the adjustments and checks required for service can be carried out easily. When these models are in test mode, the keys on the front panel work differently from normal. Adjustments and checks can be carried out by operating these keys with the correct procedure. For these models, all adjustments are carried out in test mode.

[Setting these models to test mode]

How to set this model into test mode.

1. Unplug the power cord from the AC socket.
2. Short the test mode jumper wires. (See Fig. 1.)
3. Plug the power cord back into the AC socket.

When the test mode is set correctly, the display is different from what it usually is when the power is turned on. If the display is still the same as usual, test mode has not been set correctly, so repeat Steps 1 – 3.

[Release from test mode]

Here is the procedure for releasing the test mode:

1. Press the STOP key and stop all operations.
2. Unplug the power cord from the AC socket.

[Operations of the keys in test mode]

Code	Key Name	Function in Test Mode	Explanation
	PROGRAM	Focus servo close	<p>The laser diode is lit up and the focus actuator is lowered, then raised slowly and the focus servo is closed at the point where the objective lens is focused on the disc.</p> <p>With the player in this state, if you lightly rotate the stopped disc by hand, you can hear the sound the focus servo.</p> <p>If you can hear this sound, the focus servo is operating correctly. If you press this key with no disc mounted, the laser diode lights up, the focus actuator is pulled down, then the actuator is raised and lowered three times and returned to its original position.</p>
▶/	PLAY/PAUSE	Spindle servo ON	<p>Starts the spindle motor in the clockwise direction and when the disc rotation reaches the prescribed speed (about 500rpm at the inner periphery), sets the spindle servo in a closed loop.</p> <p>Be careful. Pressing this key when there is no disc mounted makes the spindle motor run at the maximum speed.</p> <p>If the focus servo does not go correctly into a closed loop or the laser light shines on the mirror section at the outermost periphery of the disc, the same symptom is occurred.</p>
		Tracking servo close/open	<p>Pressing this key when the focus servo and spindle servo are operating correctly in closed loops puts the tracking servo into a closed loop, displays the track number being played back and the elapsed time on the front panel, and outputs the playback signal.</p> <p>If the elapsed time is not displayed or not counted correctly or the audio is not played back correctly, it may be that the laser is shining on the section with no sound recorded at the outer edge of the disc, that something is out of adjustment, or that there is some other problem.</p> <p>This key is a toggle key and open/close the tracking servo alternately. This key has no effect if no disc is mounted.</p>
◀◀• ◀◀	MANUAL TRACK SEARCH REV	Carriage reverse (inwards)	<p>Moves the pickup position toward the inner diameter of the disc. When this key is pressed with the tracking servo in a closed loop, the tracking servo automatically goes in an open loop. Since the motor does not automatically stop at the mechanical end point in test mode, be careful with this operation.</p>
▶▶• ▶▶	MANUAL TRACK SEARCH FWD	Carriage forward (outwards)	<p>Moves the pickup position toward the inner diameter of the disc. When this key is pressed with the tracking servo in a closed loop, the tracking servo automatically goes in an open loop. Since the motor does not automatically stop at the mechanical end point in test mode, be careful with this operation.</p>

Code	Key Name	Function in Test Mode	Explanation
■	STOP	Stop	Switches off all the servos and initialized. The pickup remains where it was when this key was pressed.
▲	OPEN/CLOSE	Disc tray open/close	Open/close the disc tray. This key is a toggle key and open/close tray alternately. Pressing this key when the disc is turning stops the disc, then opens the tray. This key operation does not affect the position of the pickup.

[How to play back a disc in test mode]

In test mode, since the servos operate independently, playing back a disc requires that you operate the keys in the correct order to close the servos.

Here is the key operation sequence for playing back a disc in test mode.

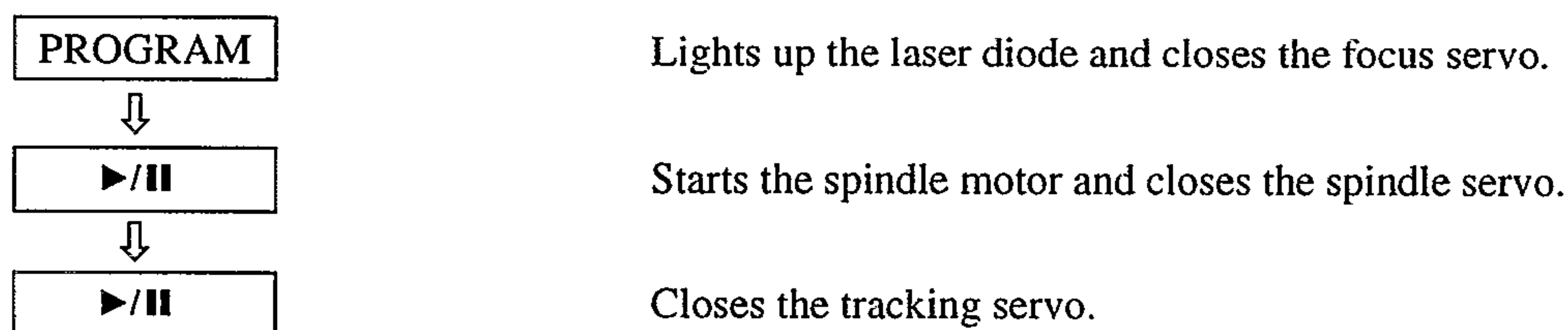

Wait at least 2 – 3 seconds between each of these operations.

1. Focus Offset Verification

<ul style="list-style-type: none"> ● Objective ● Symptom when out of adjustment 	<p>Verify the DC offset for the focus error amp.</p> <p>The model does not focus in and the RF signal is dirty.</p>		
<ul style="list-style-type: none"> ● Measurement instrument connections 	<p>Connect the oscilloscope to TP1, Pin 6 (FCS. ERR) and GND is to TP1, Pin 4 (VC).</p> <p>[Settings] 5mV/division 10 ms/division DC mode</p>	<ul style="list-style-type: none"> ● Player state ● Adjustment location ● Disc 	<p>Test mode, stopped (just the Power switch on)</p> <p>None</p> <p>None needed</p>
<p>[Procedure]</p> <p>Verify the DC voltage at TP1, Pin 6 (FCS. ERR) is 0 ± 50 mV.</p>			

Note : If the specified values cannot be obtained or no adjustment is possible by performing the verifications or adjustments described in adjustment items 1 – 4, the pickup block may be defective.

2. Tracking Error Balance Verification

<ul style="list-style-type: none"> ● Objective ● Symptom when out of adjustment 	To verify that there is no variation in the sensitivity of the tracking photo diode. Play does not start or track search is impossible.		
<ul style="list-style-type: none"> ● Measurement instrument connections 	Connect the oscilloscope to TP1. Pin 2 (TRK. ERR) and GND is to TP1, Pin 4 (VC). This connection may be via a low pass filter. [Settings] 50 mV/division 5 ms/division DC mode	<ul style="list-style-type: none"> ● Player state ● Adjustment location ● Disc 	Test mode, focus and spindle servos closed and tracking servo open None YEDS-7

[Procedure]

1. Move the pickup to midway across the disc (R=35 mm) with the MANUAL TRACK SEARCH FWD **▶▶ • ▶▶▶** or REV **◀◀ • ◀◀◀** key.
2. Press the PROGRAM key, then the PLAY/PAUSE **▶/||** key in that order to close the focus servo then the spindle servo.
3. Line up the bright line (ground) at the center of the oscilloscope screen and put the oscilloscope into DC mode.
4. Supposing that the positive amplitude of the tracking error signal at TP1, pin 2 (TRK ERR) is (A) and the negative amplitude is (B), the following expression is satisfied.

$$\text{When } A \geq B, \frac{A - B}{C} \times \frac{1}{2} \leq 0.1$$

$$\text{When } A < B, \frac{B - A}{C} \times \frac{1}{2} \leq 0.1$$

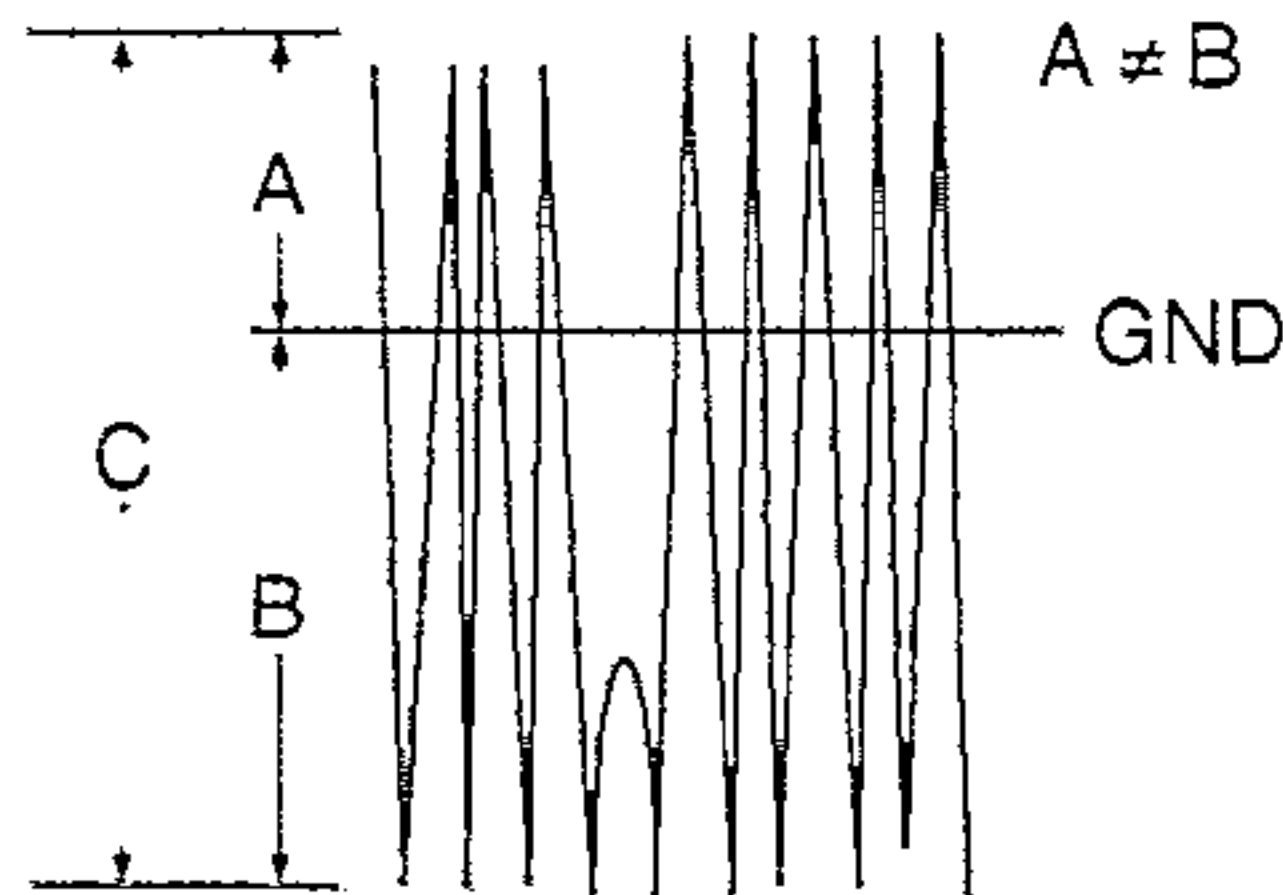

When there is a DC component

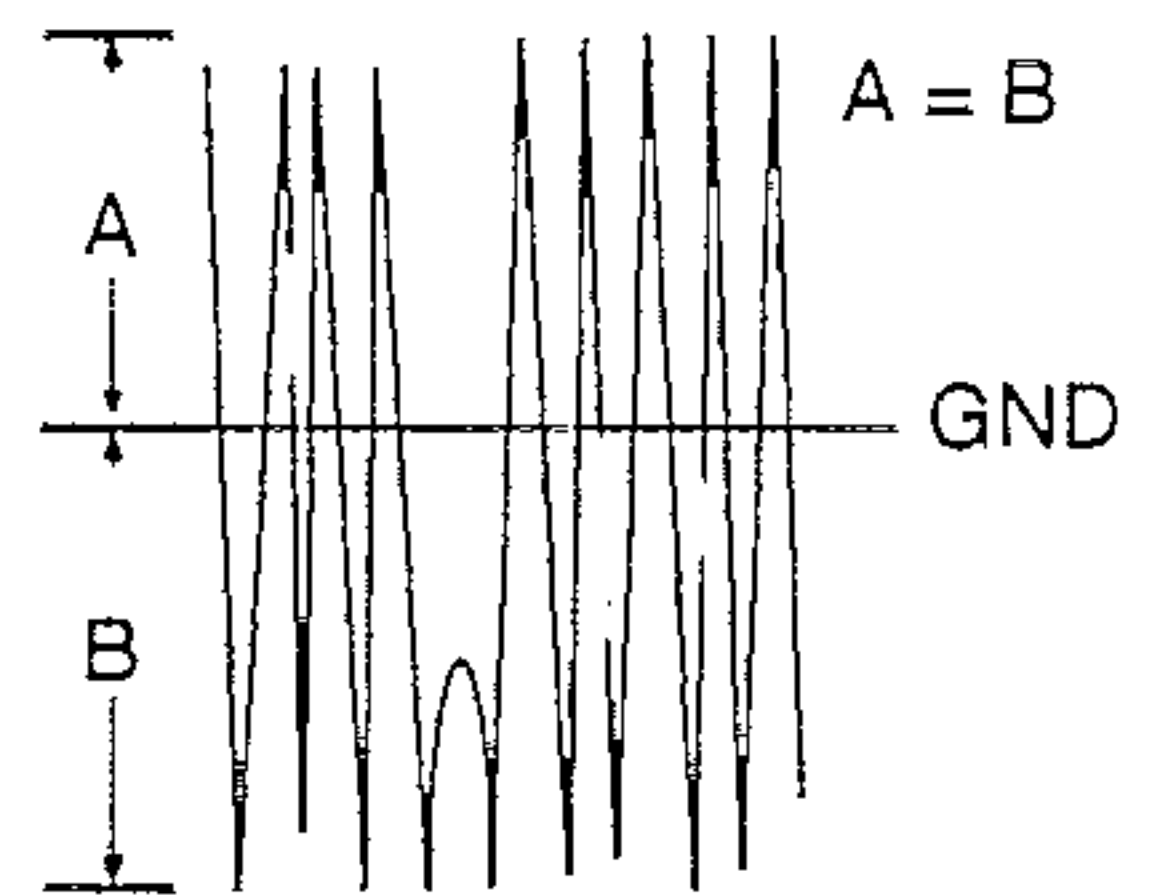

When there is no DC component

3. Pickup Radial/Tangential Tilt Adjustment

<ul style="list-style-type: none"> ● Objective 	To adjust the angle of the pickup relative to the disc so that the laser beams are shone straight down the disc for the best read out of the RF signals.		
<ul style="list-style-type: none"> ● Symptom when out of adjustment 	Sound broken; some discs can be played but not others.		
<ul style="list-style-type: none"> ● Measurement instrument connections 	Connect the oscilloscope to TP1, Pin 1 (RF) and GND is to TP1, Pin 4 (VC). [Settings] 20 mV/division 200 ns/division AC mode	<ul style="list-style-type: none"> ● Player state ● Adjustment location ● Disc 	Test mode, play Pickup radial tilt adjustment screw and tangential tilt adjustment screw 8 cm disc (However, those with approx. 20 min audio signal (music).)

[Procedure]

1. Press the MANUAL TRACK SEARCH FWD ►► • ►►| or REV |◄◄ • ◄◄ key to move the pickup to the external circumference of the disc.

Press the PROGRAM key, the PLAY/PAUSE ►/|| key twice in that order to close the respective servos and put the player into play mode.
2. First, adjust the radial tilt adjustment screw with the hexagon wrench (GGK1002) so that the eye pattern (the diamond shape at the center of the RF signal) can be seen the most clearly.
3. Next, adjust the tangential tilt adjustment screw with the hexagon wrench (GGK1002) so that the eye pattern (the diamond shape at the center of the RF signal) can be seen the most clearly (Fig. 3).
4. Adjust the radial tilt adjustment screw and the tangential tilt adjustment screw again so that the eye pattern can be seen the most clearly. As necessary, adjust the two screws alternately so that the eye pattern can be seen the most clearly.
5. When the adjustment is completed, lock the radial and tangential adjustment screw.

Note: Radial and tangential mean the directions relative to the disc shown in Fig. 2.

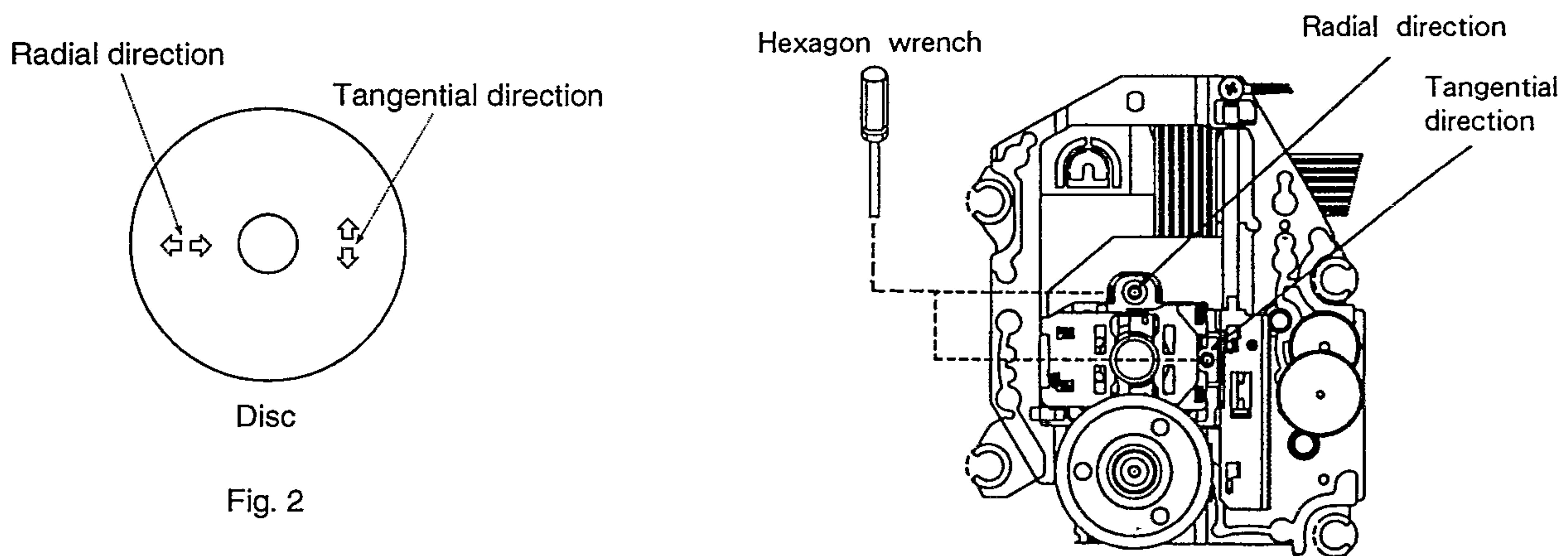

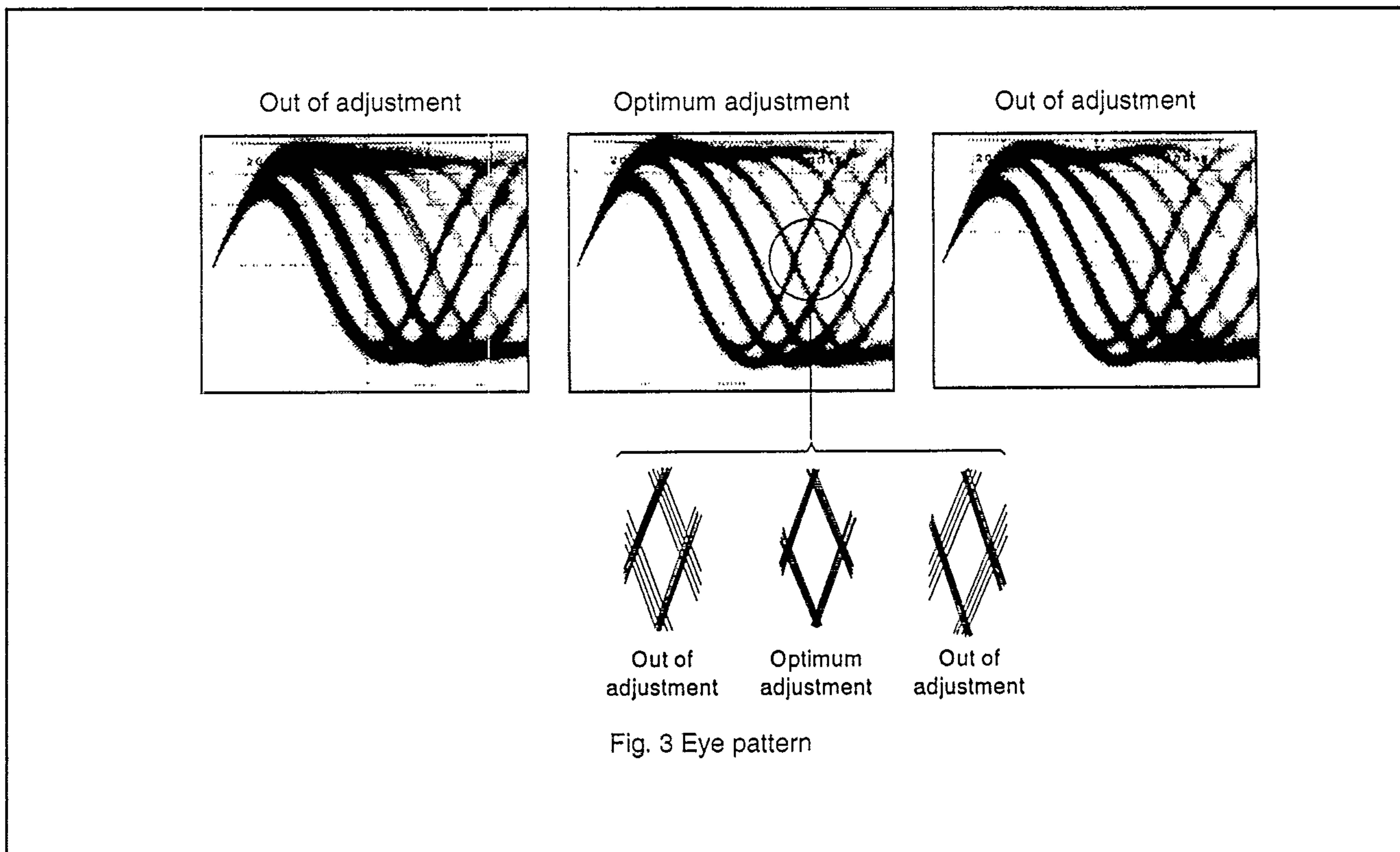

Fig. 3 Eye pattern

4. RF Level Verification

<ul style="list-style-type: none"> ● Objective 	To verify the playback RF signal amplitude.		
<ul style="list-style-type: none"> ● Symptom when out of adjustment 	No play or no search.		
<ul style="list-style-type: none"> ● Measurement instrument connections 	Connect the oscilloscope to TP1, Pin 1 (RF) and GND is to TP1, Pin 4 (VC). [Settings] 50 mV/division 10 ms/division AC mode	<ul style="list-style-type: none"> ● Player state ● Adjustment location ● Disc 	Test mode, play None YEDS-7
<p>[Procedure]</p> <ol style="list-style-type: none"> 1. Move the pickup to midway across the disc (R=35 mm) with the MANUAL TRACK SEARCH FWD ►►•►► or REV ◄◄•◄◄ key, then press the PROGRAM key, the PLAY/PAUSE ►/ key twice in that order to close the respective servos and put the player into play mode. 2. Verify the RF signal amplitude is 1.2 Vp-p ± 0.2 V. 			

5. Focus Servo Loop Gain Adjustment

<ul style="list-style-type: none"> ● Objective 	To optimize the focus servo loop gain.		
<ul style="list-style-type: none"> ● Symptom when out of adjustment 	Playback does not start or focus actuator noisy.		
<ul style="list-style-type: none"> ● Measurement instrument connections 	See figure 4. [Settings] CH1 CH2 20 mV/division 5 mV/division X - Y mode	<ul style="list-style-type: none"> ● Player state ● Adjustment location ● Disc 	Test mode, play VR152 (FCS. GAN) YEDS-7

[Procedure]

1. Set the AF generator output to 1.2 kHz and 1 Vp-p.
2. Press the MANUAL TRACK SEARCH FWD **▶▶ • ▶▶▶** or REV **◀◀ • ◀◀◀** key to move the pickup to halfway across the disc (R=35 mm), then press the PGM (PROGRAM) key, the PLAY/PAUSE **▶/||** key twice in that order to close the corresponding servos and put the player into play mode.
3. Adjust VR152 (FCS. GAN) so that the Lissajous waveform is symmetrical about the X axis and the Y axis.

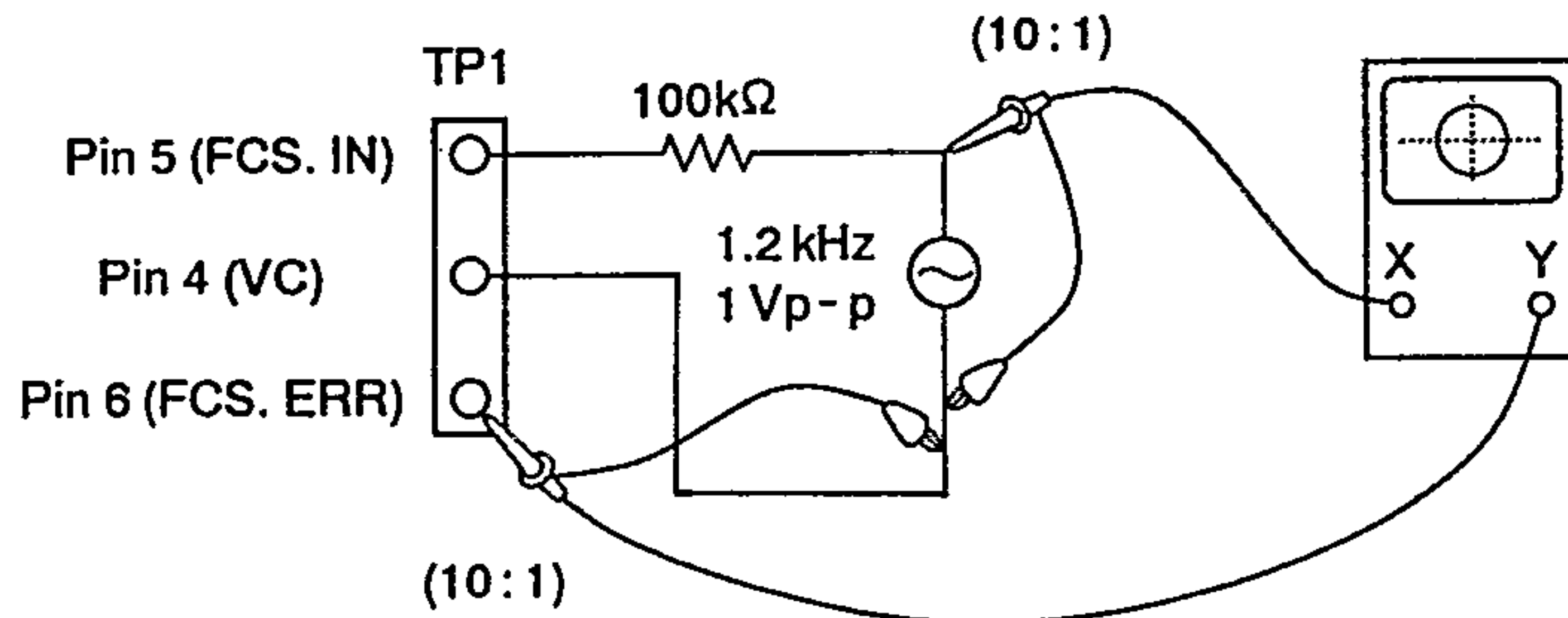
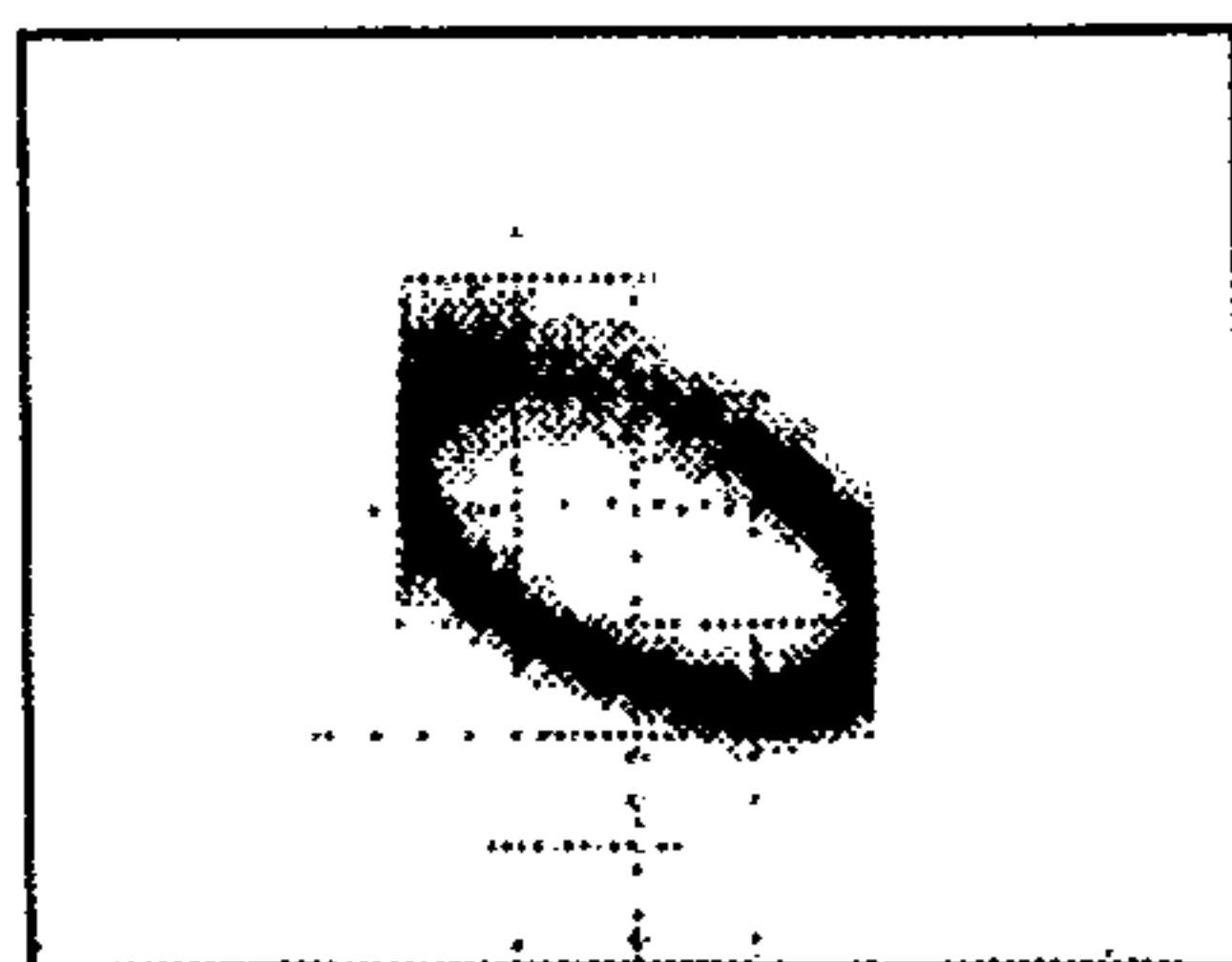
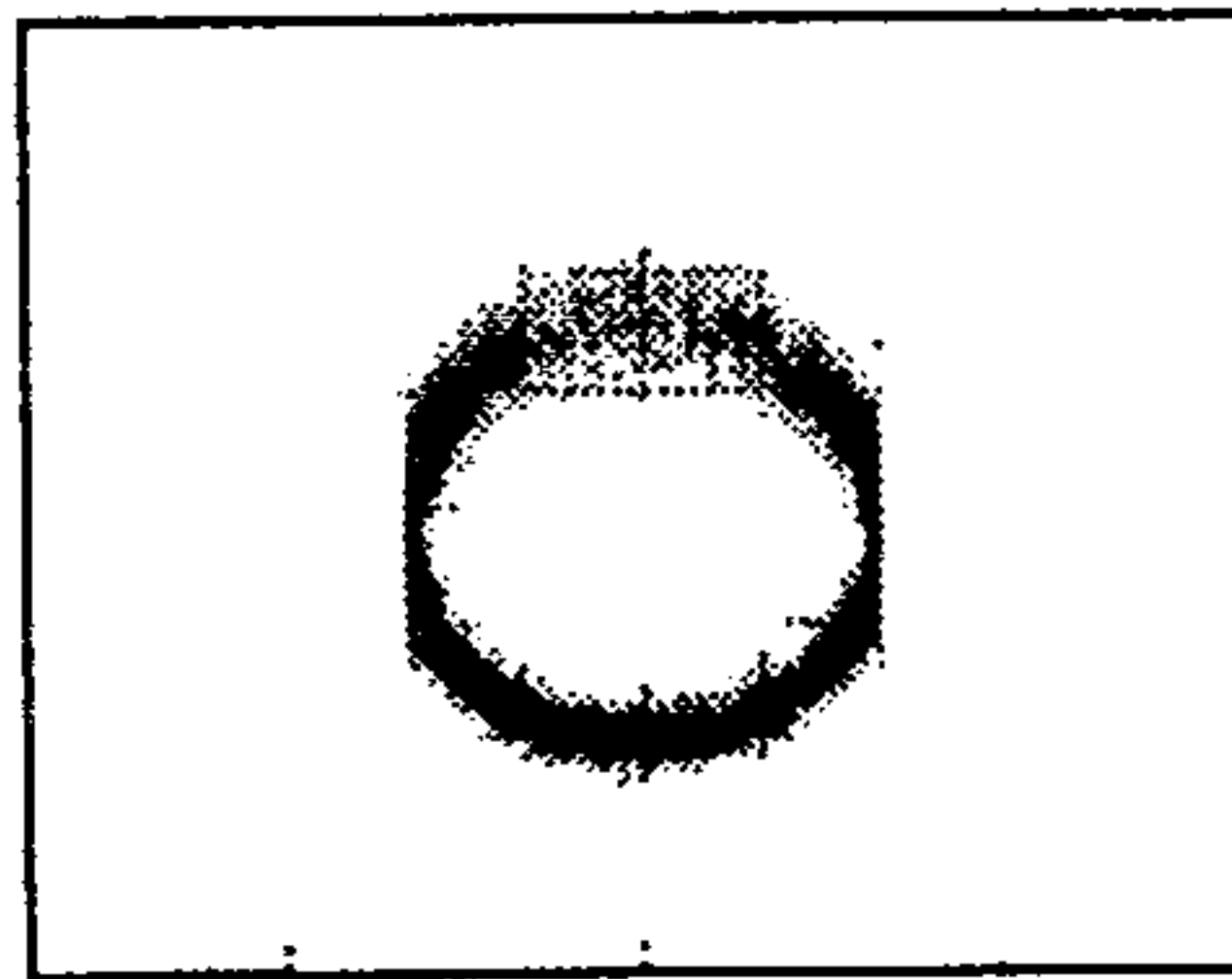

Fig. 4

Focus Gain Adjustment



Higher gain



Optimum gain

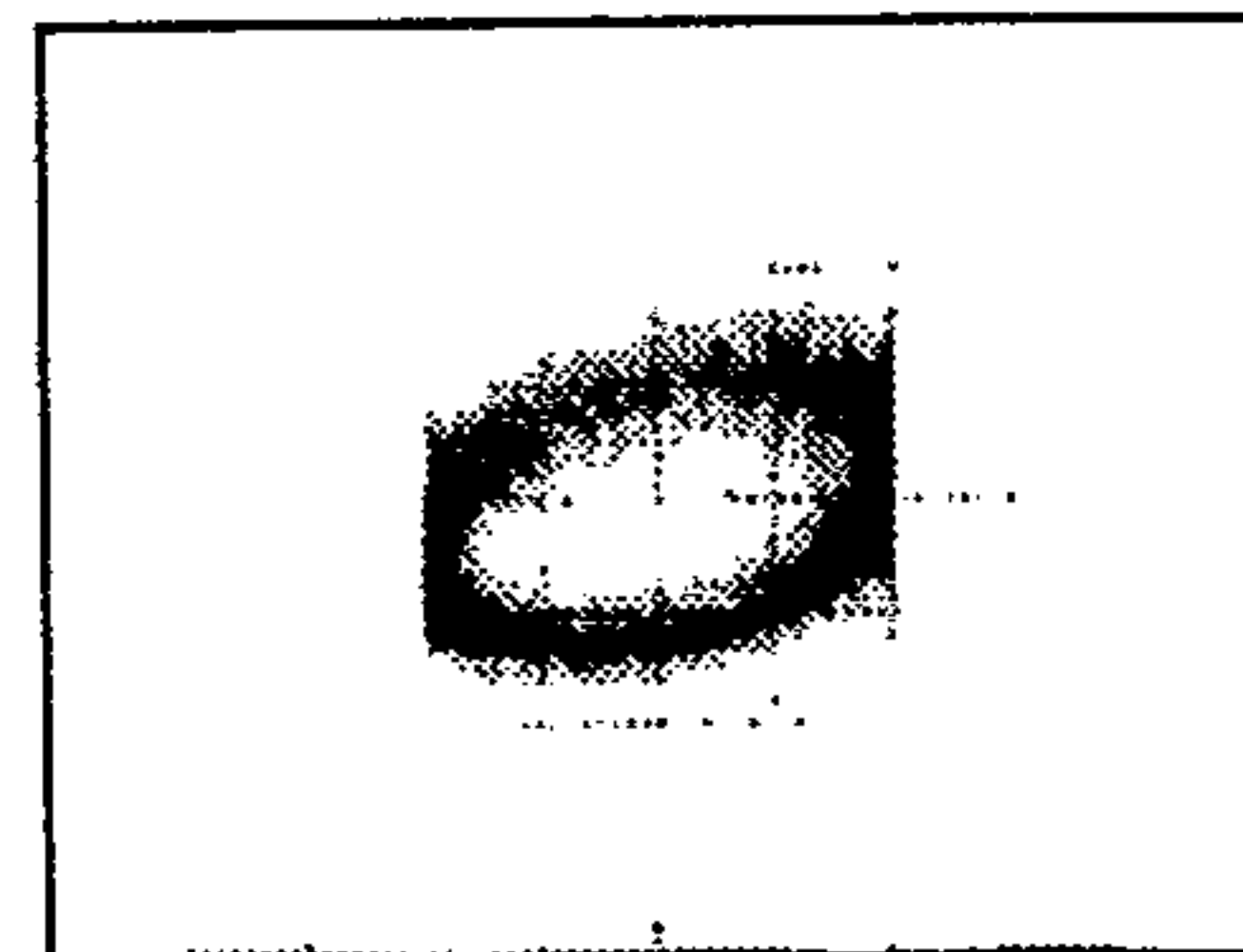

Lower gain

6. Tracking Servo Loop Gain Adjustment

<ul style="list-style-type: none"> ● Objective 	To optimize the focus servo loop gain.		
<ul style="list-style-type: none"> ● Symptom when out of adjustment 	Playback does not start, during searches the actuator is noisy, or tracks are skipped.		
<ul style="list-style-type: none"> ● Measurement instrument connections 	See figure 5. [Settings] CH1 CH2 50 mV/division 20 mV/division X - Y mode	<ul style="list-style-type: none"> ● Player state ● Adjustment location ● Disc 	Test mode, play VR151 (TRK. GAN) YEDS-7

[Procedure]

1. Set the AF generator output to 1.2 kHz and 2 Vp-p.
2. Press the MANUAL TRACK SEARCH FWD **▶▶ • ▶▶▶** or REV **◀◀ • ◀◀◀** key to move the pickup to halfway across the disc (R=35 mm), then press the PGM (PROGRAM) key, the PLAY/PAUSE **▶/||** key twice in that order to close the corresponding servos and put the player into play mode.
3. Adjust VR151 (TRK. GAN) so that the Lissajous waveform is symmetrical about the X axis and the Y axis.

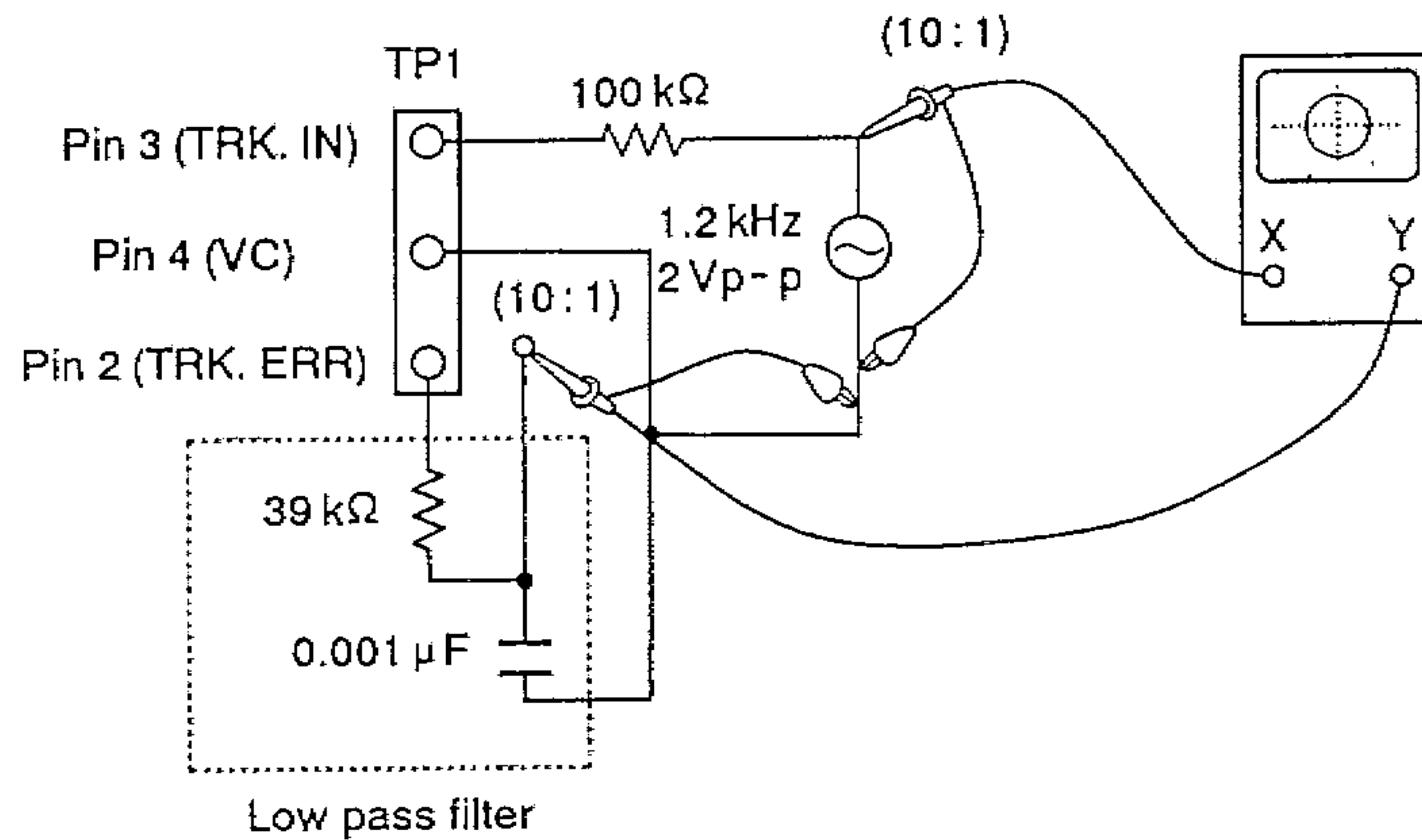
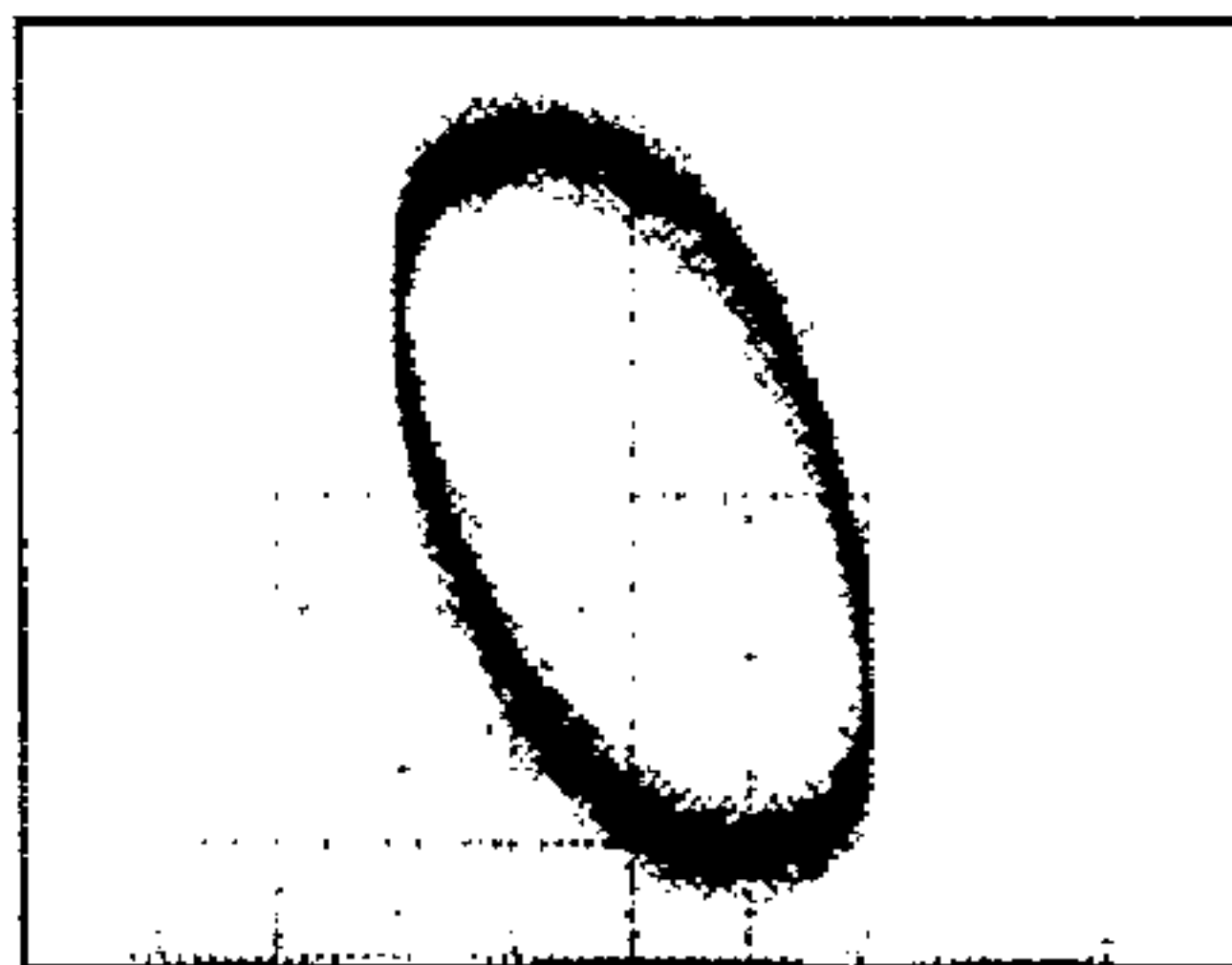
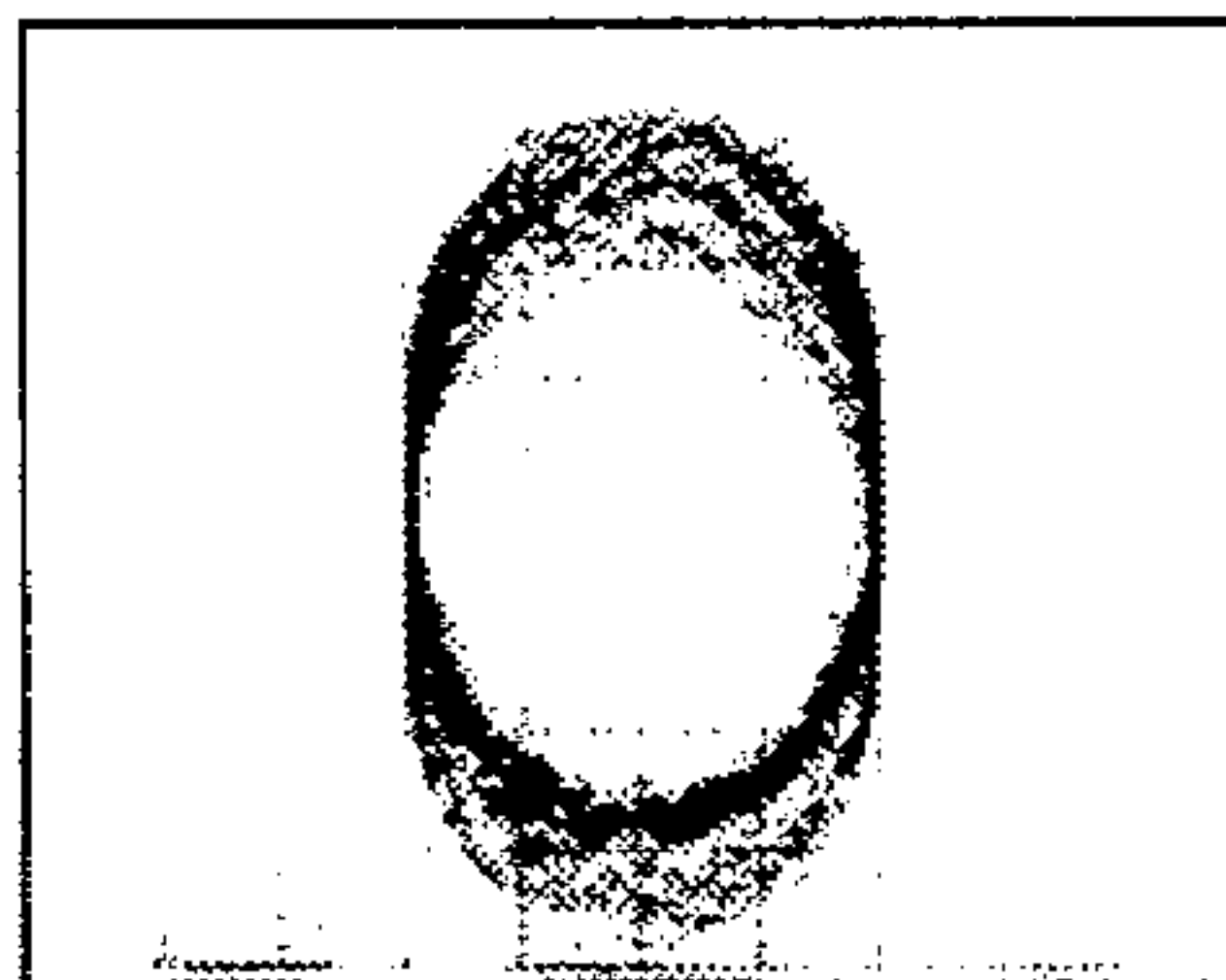

Fig. 5

Tracking Gain Adjustment



Higher gain



Optimum gain

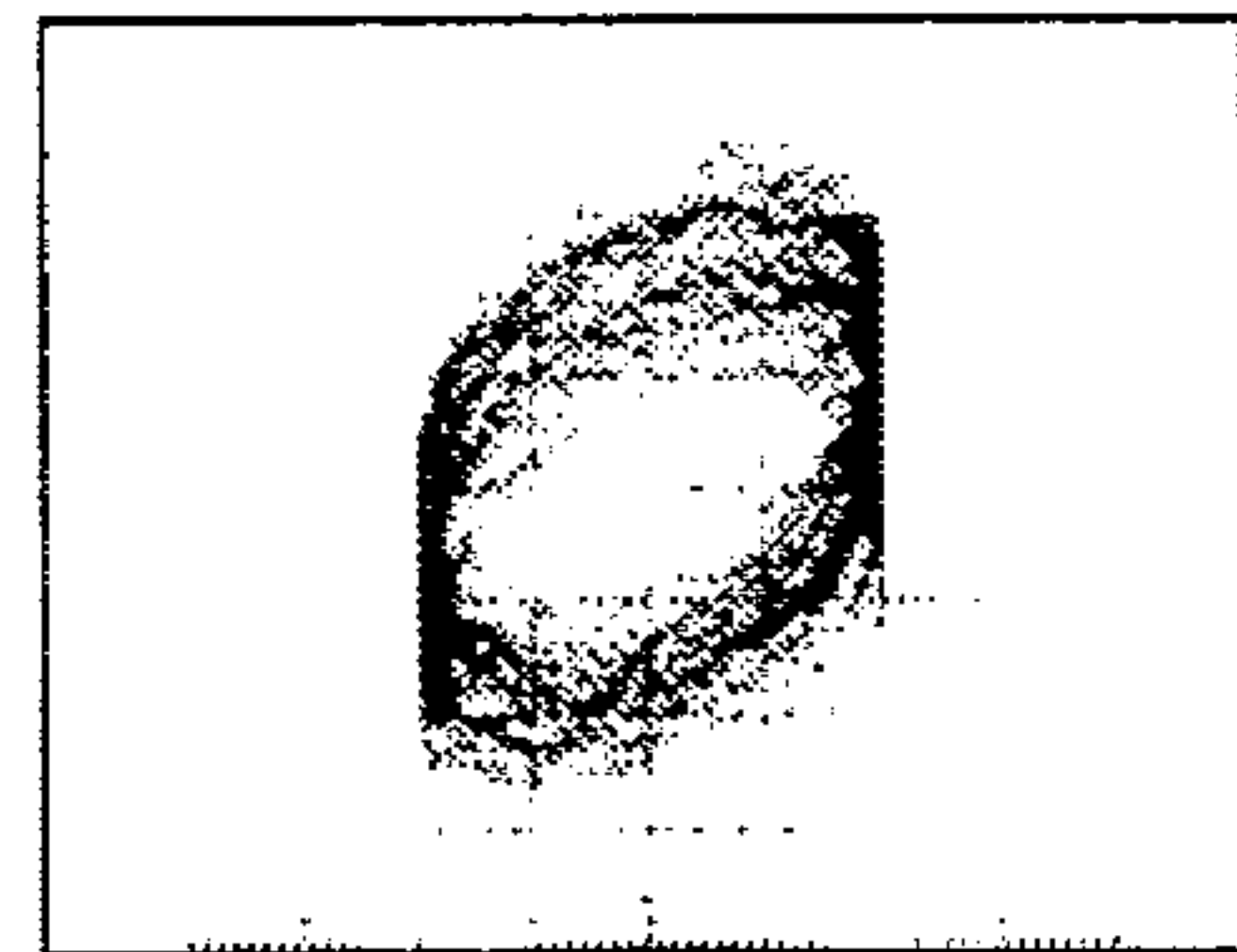

Lower gain

6. IC INFORMATION

- The information shown in the list is basic information and may not correspond exactly to that shown in the schematic diagrams.

■ PD4590A (MOTHER BOARD ASSY, IC351)

SYSTEM CONTROL

● Pin Function

Pin No.	NAME	I/O	FUNCTION
1	$\overline{\text{REST}}$	–	CPU reset (L : Reset)
2	G1	O	FL drive digit output
3	G2	O	FL drive digit output
4	G3	O	FL drive digit output
5	G4	O	FL drive digit output
6	G5	O	FL drive digit output
7	G6	O	FL drive digit output
8	G7	O	FL drive digit output
9	G8	O	FL drive digit output
10	G9	O	FL drive digit output
11	G10	O	FL drive digit output
12	$\overline{\text{MUTE}}$	O	Muting output (L : Muting, H : OFF)
13	SYC3	O	Sync output
14	VOLL	O	Electrically operated volume LED output (L : Goes off, H : Lights)
15	STBY	O	Standby LED output (L : Goes off, H : Lights), OSCE output
16	SEG l	O	FL drive segment output
17	SEG k	O	FL drive segment output
18	VLOAD	–	–26V
19	VPRE	–	–5V
20	SEG j	O	FL drive segment output
21	SEG i	O	FL drive segment output
22	SEG d	O	FL drive segment output
23	SEG c	O	FL drive segment output
24	SEG b	O	FL drive segment output
25	SEG a	O	FL drive segment output
26	VDD	–	+5V
27	SEG h	O	FL drive segment output
28	SEG g	O	FL drive segment output
29	SEG f	O	FL drive segment output
30	SEG e	O	FL drive segment output
31	SYC1	I	Sync input (Pull-up required.)
32	CLOK	O	Serial clock and model switching discrimination port *Note 2

Pin No.	NAME	I/O	FUNCTION
33	DATA	O	LSI control data serial output
34	SQSO	I	Subcode Q data serial input
35	RMDT	I	Remote control data input
36	SCOR	I	Subcode sync S0+S1 input
37	$\overline{\text{INS D}}$	I	Slider inside SW input (L : Inside)
38	FCOK	I	Focus OK input (H : OK, L : NG)
39	VOLD	O	Electrically operated volume up/down (*Note 3)
40	VOLU	O	
41	LIN	O	Disc tray in/out (*Note 4)
42	LOUT	O	
43	NC	O	Not used. (open)
44	NC	O	
45	$\overline{\text{OPEN}}$	I	Disc tray opening completion SW input
46	$\overline{\text{CLPM}}$	I	Disc tray clamping completion SW input
47	NC	O	Not used. (open)
48	NC	O	
49	SENS	I	LSI operating status multiple modes input
50	GFS	I	Frame sync lock input (H : OK, L : NG)
51	MUTE	O	Muting output (H : Muting, L : OFF)
52	DLAT	O	Digital filter IC latch pulse
53	XLAT	O	LSI control data latch pulse
54	$\overline{\text{XRST}}$	O	LSI reset (L : Reset, H : Cancel)
55	$\overline{\text{LDON}}$	O	Laser diode output (H : OFF, L : ON)
56	X1	-	Main system clock oscillation (4.194304 MHz)
57	X2	-	
58	Vss	-	GND
59	XT1	-	GND
60	XT2	-	Not used. (open)
61	KD0/TEST	I	Key scanning input and TEST mode request input *Note 1
62	KD1	I	Key scanning input
63	KD2	I	Key scanning input
64	KD3	I	Key scanning input

*Note 1 Discriminated when the power is ON.

*Note 2 Discriminated when the inlet is ON.

H : (Electrically operated volume)

L : (ATT)

*Note 3

	VOLD	VOLU
Volume UP	L	H
DOWN	H	L
STOP	L	L

*Note 4

	LOUT	LIN
Tray IN	L	H
OUT	H	L
STOP	L	L

7. BLOCK DIAGRAM

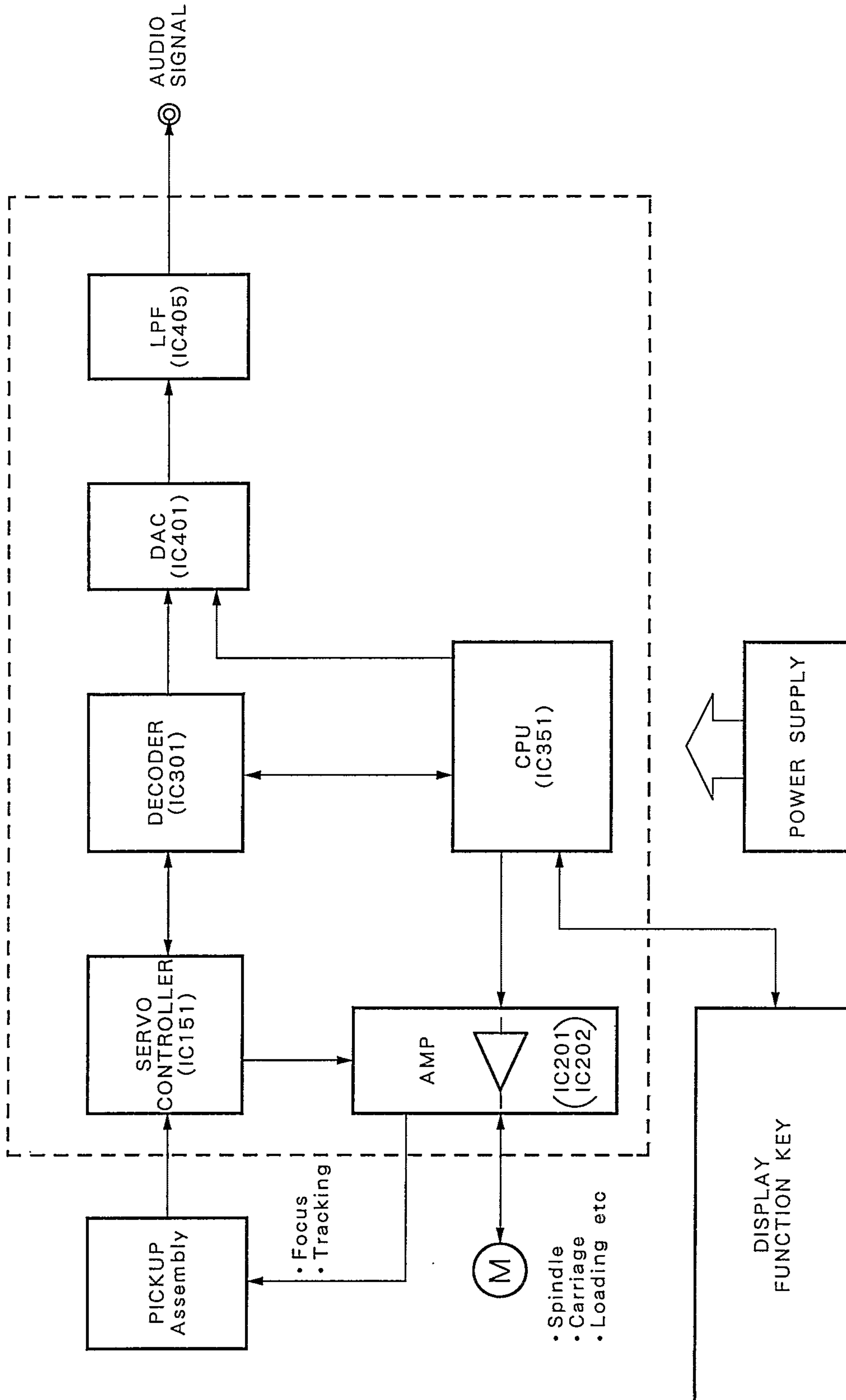

8. CONTRAST OF MISCELLANEOUS PARTS

NOTES:

- Parts marked by "NSP" are generally unavailable because they are not in our Master Spare Parts List.
- The Δ mark found on some component parts indicates the importance of the safety factor of the part. Therefore, when replacing, be sure to use parts of identical designation.
- Parts marked by "⊙" are not always kept in stock. Their delivery time may be longer than usual or they may be unavailable.

■ CONTRAST OF PD-204/WBW XK, WPWXJ, WLXJ, RDXJ, AND WEMXK

PD-204/WBW XK, WPWXJ, WLXJ, RDXJ and WEMXK have the same construction except for the following :

Mark	Symbol & Description	Part No.					Remarks
		PD-204					
		WEMXK	WBW XK	WPWXJ	WLXJ	RDXJ	
Δ	MOTHER BOARD ASSY	PWM1936	PWM1936	PWM1937	PWM1937	PWM1938	
NSP	SUB BOARD ASSY	PWX1396	PWX1396	PWX1395	PWX1395	PWX1395	
	└─ FUNCTION BOARD ASSY	PWZ2933	PWZ2933	PWZ2932	PWZ2932	PWZ2932	
NSP	└─ SWITCH BOARD ASSY	PWZ2940	PWZ2940	PWZ2939	PWZ2939	PWZ2939	
	└─ HEADPHONE BOARD ASSY	PWZ2948	PWZ2948	PWZ2947	PWZ2947	PWZ2947	
Δ	AC power cord	PDG1003	PDG1055	RDG1022	PDG1003	PDG1056	
Δ	Fuse (T5A)	Not Used	PEK1003	Not Used	Not Used	Not Used	* 1
Δ	Power transformer (AC220-240V)	PTT1236	PTT1236	PTT1236	PTT1236	Not Used	
Δ	Power transformer (AC110-127V/220-240V)	Not Used	Not Used	Not Used	Not Used	PTT1238	
	Function panel	PNW2546	PNW2546	PNW2545	PNW2545	PNW2545	
	Display window WT	PAM1665	PAM1665	Not Used	Not Used	Not Used	
	Display window OR	Not Used	Not Used	PAM1666	PAM1666	PAM1666	
	Insulator	PNW1912	PNW1912	Not Used	Not Used	Not Used	
	Foot assy	Not Used	Not Used	AEC1531	AEC1531	AEC1531	* 1
	Rubber sheet	Not Used	Not Used	AEB1111	AEB1111	AEB1111	* 1
NSP	Bonnet	PYY1183	PYY1183	PYY1182	PYY1182	PYY1182	
	Under base	PNA2219	PNA2219	PNA2177	PNA2177	PNA2177	
	Rear base	PNA2188	PNA2189	PNA2191	PNA2192	PNA2190	
	Operating instructions (English)	PRB1223	PRB1223	Not Used	Not Used	Not Used	
	Operating instructions (German/French/Italian/Dutch/Swedish/Spanish/Portuguese)	PRE1212	Not Used	Not Used	Not Used	Not Used	
	Operating instructions (English/Spanish/Chinese)	Not Used	Not Used	PRE1213	PRE1213	PRE1213	
	Packing case	PHG2153	PHG2113	PHG2111	PHG2111	PHG2111	
	Protector front	Not Used	PHA1239	Not Used	Not Used	Not Used	* 1
	Protector rear	Not Used	PHA1254	Not Used	Not Used	Not Used	* 1
	Spacer	Not Used	PHC1075	Not Used	Not Used	Not Used	* 1
	Protector R	Not Used	Not Used	PHA1289	PHA1289	PHA1289	* 1
	Protector L	Not Used	Not Used	PHA1290	PHA1290	PHA1290	* 1
	Paper protector	PHA1297	Not Used	Not Used	Not Used	Not Used	
	Paper spacer	PHA1298	Not Used	Not Used	Not Used	Not Used	
	Packing sheet	AHG1090	Z23 - 007	Z23 - 007	Z23 - 007	Z23 - 007	
NSP	Caution label HE	PRW1233	Not Used	Not Used	Not Used	Not Used	
	Caution label (F)	VRW - 328	VRW - 328	Not Used	VRW - 328	Not Used	
	Caution label (G)	VRW - 329	VRW - 329	Not Used	VRW - 329	Not Used	
	Caution label	VRW1094	Not Used	Not Used	Not Used	Not Used	
	Caution label	Not Used	PRW1018	PRW1018	PRW1018	Not Used	* 2
	Polyethylene bag	Z21 - 038	Not Used	Z21 - 038	Z21 - 038	Z21 - 038	
	Polyethylene bag	Not Used	Z21 - 013	Not Used	Not Used	Not Used	For AC power cord

Note * 1: Refer to "2. EXPLODED VIEWS, PACKING AND PARTS LIST".
* 2: Refer to page 2.

■ CONTRAST OF PD-104/WEMXK, WBWXK, WPWXJ, WLXJ, RDXJ, AND PD-204/WEMXK

PD-104/WEMXK, WBWXK, WPWXJ, WLXJ, RDXJ and PD-204/WEMXK have the same construction except for the following :

Mark	Symbol & Description	Part No.						Remarks
		PD-204/ WEMXK	PD-104/ WEMXK	PD-104/ WBWXK	PD-104/ WPWXJ	PD-104/ WLXJ	PD-104/ RDXJ	
△ NSP	MOTHER BOARD ASSY	PWM1936	PWM1931	PWM1931	PWM1932	PWM1932	PWM1933	
	SUB BOARD ASSY	PWX1396	PWX1394	PWX1394	PWX1393	PWX1393	PWX1393	
	└─ FUNCTION BOARD ASSY	PWZ2933	PWZ2931	PWZ2931	PWZ2930	PWZ2930	PWZ2930	
NSP	└─ SWITCH BOARD ASSY	PWZ2940	PWZ2940	PWZ2940	PWZ2939	PWZ2939	PWZ2939	
	└─ HEADPHONE BOARD ASSY	PWZ2948	PWZ2946	PWZ2946	Not Used	Not Used	Not Used	
△	AC power cord	PDG1003	PDG1003	PDG1055	RDG1022	PDG1003	PDG1056	* 1
△	Fuse (T5A)	Not Used	Not Used	PEK1003	Not Used	Not Used	Not Used	
△	Power transformer (AC220-240V)	PTT1236	PTT1236	PTT1236	PTT1236	PTT1236	Not Used	
△	Power transformer (AC110-127V/220-240V)	Not Used	Not Used	Not Used	Not Used	Not Used	PTT1238	
	32P FFC/30V	PDD1041	Not Used	Not Used	Not Used	Not Used	Not Used	
	30P FFC/30V	Not Used	PDD1049	PDD1049	PDD1049	PDD1049	PDD1049	
	Function panel	PNW2546	PNW2544	PNW2544	PNW2540	PNW2540	PNW2540	
	Display window WT	PAM1665	PAM1661	PAM1661	Not Used	Not Used	Not Used	
	Display window OR	Not Used	Not Used	Not Used	PAM1667	PAM1667	PAM1667	
	Tray name plate	PNW2539	PNW2539	PNW2539	PNW2547	PNW2547	PNW2547	
	Headphone knob	PAC1707	PAC1707	PAC1707	Not Used	Not Used	Not Used	
	Insulator	PNW1912	PNW1912	PNW1912	Not Used	Not Used	Not Used	
	Foot assy	Not Used	Not Used	Not Used	AEC1531	AEC1531	AEC1531	* 1
	Rubber sheet	Not Used	Not Used	Not Used	AEB1111	AEB1111	AEB1111	* 1
	Bonnet	PYY1183	PYY1183	PYY1183	PYY1182	PYY1182	PYY1182	
NSP	Under base	PNA2219	PNA2219	PNA2219	PNA2177	PNA2177	PNA2177	
	Rear base	PNA2188	PNA2178	PNA2184	PNA2186	PNA2187	PNA2185	
	Operating instructions (English)	PRB1223	PRB1223	PRB1223	Not Used	Not Used	Not Used	
	Operating instructions (German/French/Italian/Dutch/Swedish/Spanish/Portuguese)	PRE1212	PRE1212	Not Used	Not Used	Not Used	Not Used	
	Operating instructions (English/Spanish/Chinese)	Not Used	Not Used	Not Used	PRE1213	PRE1213	PRE1213	
	Remote control unit	PWW1061	Not Used	Not Used	Not Used	Not Used	Not Used	
	Battery cover	PZN1010	Not Used	Not Used	Not Used	Not Used	Not Used	
NSP	Battery (R03, AAA)	VEM - 022	Not Used	Not Used	Not Used	Not Used	Not Used	
	Cord with mini plug	Not Used	PDE1247	PDE1247	PDE1247	PDE1247	PDE1247	For packing
	Packing case	PHG2153	PHG2152	PHG2109	PHG2105	PHG2105	PHG2105	
	Protector front	Not Used	Not Used	PHA1239	Not Used	Not Used	Not Used	* 1
	Protector rear	Not Used	Not Used	PHA1254	Not Used	Not Used	Not Used	* 1
	Spacer	Not Used	Not Used	PHC1075	Not Used	Not Used	Not Used	* 1
	Protector R	Not Used	Not Used	Not Used	PHA1289	PHA1289	PHA1289	* 1
	Protector L	Not Used	Not Used	Not Used	PHA1290	PHA1290	PHA1290	* 1
	Paper protector	PHA1297	PHA1297	Not Used	Not Used	Not Used	Not Used	
	Paper spacer	PHA1298	PHA1298	Not Used	Not Used	Not Used	Not Used	
	Packing sheet	AHG1090	AHG1090	Z23 - 007	Z23 - 007	Z23 - 007	Z23 - 007	
	Caution label HE	PRW1233	PRW1233	Not Used	Not Used	Not Used	Not Used	
NSP	Caution label (F)	VRW - 328	VRW - 328	VRW - 328	Not Used	VRW - 328	Not Used	
	Caution label (G)	VRW - 329	VRW - 329	VRW - 329	Not Used	VRW - 329	Not Used	
	Caution label	VRW1094	VRW1094	Not Used	Not Used	Not Used	Not Used	* 2
	Caution label	Not Used	Not Used	PRW1018	PRW1018	PRW1018	Not Used	
	Polyethylene bag	Z21 - 038	Not Used	Not Used	Not Used	Not Used	Not Used	
	Polyethylene bag	Not Used	Not Used	Z21 - 013	Not Used	Not Used	Not Used	For AC power cord

Note * 1: Refer to "2. EXPLODED VIEWS, PACKING AND PARTS LIST".
* 2: Refer to page 2.

■ CONTRAST OF PD-004/WEXK/FR AND PD-204/WEMXK

PD-004/WEXK/FR and PD-204/WEMXK have the same construction except for the following:

Mark	Symbol & Description	Part No.		Remarks
		PD-204/ WEMXK	PD-004/ WEXK/FR	
△	MOTHER BOARD ASSY	PWM1936	PWM1929	
NSP	SUB BOARD ASSY	PWX1396	PWX*392	
NSP	└─ FUNCTION BOARD ASSY	PWZ2933	PWZ2929	
	└─ SWITCH BOARD ASSY	PWZ2940	PWZ2938	
	└─ HEADPHONE BOARD ASSY	PWZ2948	Not Used	
	32P FFC/30V	PDD1041	Not Used	
	30P FFC/30V	Not Used	PDD1049	
	Function panel	PNW2546	PNW2543	
	Display window WT	PAM1665	PAM1664	
	10 key	PAC1797	Not Used	
	Tray name plate	PNW2539	PNW2547	
	Headphone knob	PAC1707	Not Used	
	Insulator	PNW1912	Not Used	
	Foot assy	Not Used	AEC1222	* 1
	Rubber sheet	Not Used	AEB1111	* 1
	Rear base	PNA2188	PNA2183	
	Operating instruction (English)	PRB1223	Not Used	
	Operating instructions (German/French/Italian/Dutch/ Swedish/Spanish/Portuguese)	PRE1212	Not Used	
	Operating instructions (French)	Not Used	PRD1003	
	Remote control unit	PWW1061	Not Used	
NSP	Battery cover	PZN1010	Not Used	
	Battery (R03, AAA)	VEM - 022	Not Used	
	Cord with mini plug	Not Used	PDE1247	For packing
	Packing case	PHG2153	PHG2154	
	Polyethylene bag	Z21 - 038	Not Used	

Note * 1: Refer to "2. EXPLODED VIEWS, PACKING AND PARTS LIST".

MOTHER BOARD ASSY

PWM1937, PWM1938, PWM1931, PWM1932, PWM1933, PWM1929 and PWM1936 have the same construction except for the following:

Mark	Symbol & Description	Part No.							Remarks
		PWM1936	PWM1937	PWM1938	PWM1931	PWM1932	PWM1933	PWM1929	
	C29 C393 C413 – C416 C433, C434 C441, C442	CEAS101M35 Not Used CFTYA104J50 PCH1107 PCL1030	CEAS101M35 Not Used CFTYA104J50 PCH1107 PCL1030	CEAS101M35 Not Used CFTYA104J50 PCH1107 PCL1030	Not Used CCCSL101J50 CFTYA104J50 CEAS220M25 PCL1030	Not Used CCCSL101J50 CFTYA104J50 CEAS220M25 PCL1030	Not Used CCCSL101J50 CFTYA104J50 CEAS220M25 PCL1030	Not Used CCCSL101J50 CGCYF104Z25 CEAS220M25 CKCYB152K50	* 3
	CN351 CN401 D392 – D394 D451, D452 IC405	9604S – 32C 52147 – 0310 Not Used 1SS254 NJM4565D-D	9604S – 32C 52147 – 0310 Not Used 1SS254 NJM4565D-D	9604S – 32C 52147 – 0310 Not Used 1SS254 NJM4565D-D	9604S – 30C 52147 – 0310 1SS254 1SS254 NJM4558D-D	9604S – 30C Not Used 1SS254 Not Used NJM4558D-D	9604S – 30C Not Used 1SS254 Not Used NJM4558D-D	9604S – 30C Not Used 1SS254 Not Used NJM4558D-D	* 3
	IC406 JA391, JA392 L391 Q451, Q452 Q453, Q454	BA15218 Not Used Not Used DTC124ES 2SJ103	BA15218 Not Used Not Used DTC124ES 2SJ103	BA15218 Not Used Not Used DTC124ES 2SJ103	BA15218 RKN1004 LAU010J DTC124ES 2SJ103	Not Used RKN1004 LAU010J Not Used Not Used	Not Used RKN1004 LAU010J Not Used Not Used	Not Used RKN1004 LAU010J Not Used Not Used	* 3 * 3
	R391 R392 R451, R452 R457, R458, R472, R473 R470, R471	Not Used Not Used RD1/6PM103J RD1/6PM102J RD1/6PM470J	Not Used Not Used RD1/6PM103J RD1/6PM102J RD1/6PM470J	Not Used Not Used RD1/6PM103J RD1/6PM102J RD1/6PM470J	RD1/6PM244J RD1/6PM102J RD1/6PM103J RD1/6PM102J RD1/6PM470J	RD1/6PM244J RD1/6PM102J Not Used Not Used Not Used	RD1/6PM244J RD1/6PM102J Not Used Not Used Not Used	RD1/6PM244J RD1/6PM102J Not Used Not Used Not Used	* 3 * 3
△	S5	Not Used	Not Used	PSB1006	Not Used	Not Used	PSB1006	Not Used	

Note *3: Refer to "3. SCHEMATIC AND PCB CONNECTION DIAGRAMS".

FUNCTION BOARD ASSY

PWZ2932, PWZ2931, PWZ2930, PWZ2929 and PWZ2933 have the same construction except for the following:

Mark	Symbol & Description	Part No.					Remarks
		PWZ2933	PWZ2932	PWZ2931	PWZ2930	PWZ2929	
	CN 701 D705, D706 S715 – S724, S728 Remote Sensor	9607S – 32F 1SS254 PSG1006 SBX1785-51	9607S – 32F 1SS254 PSG1006 SBX1785-51	9607S – 30F 1SS254 PSG1006 Not Used	9607S – 30F 1SS254 PSG1006 Not Used	9607S – 30F Not Used Not Used Not Used	

SWITCH BOARD ASSY

Although PWZ2938, PWZ2939 and PWZ2940 are different in part number, they consist of the same component.

HEADPHONE BOARD ASSY

Although PWZ2946, PWZ2947 and PWZ2948 are different in part number, they consist of the same component.

9. PANEL FACILITIES

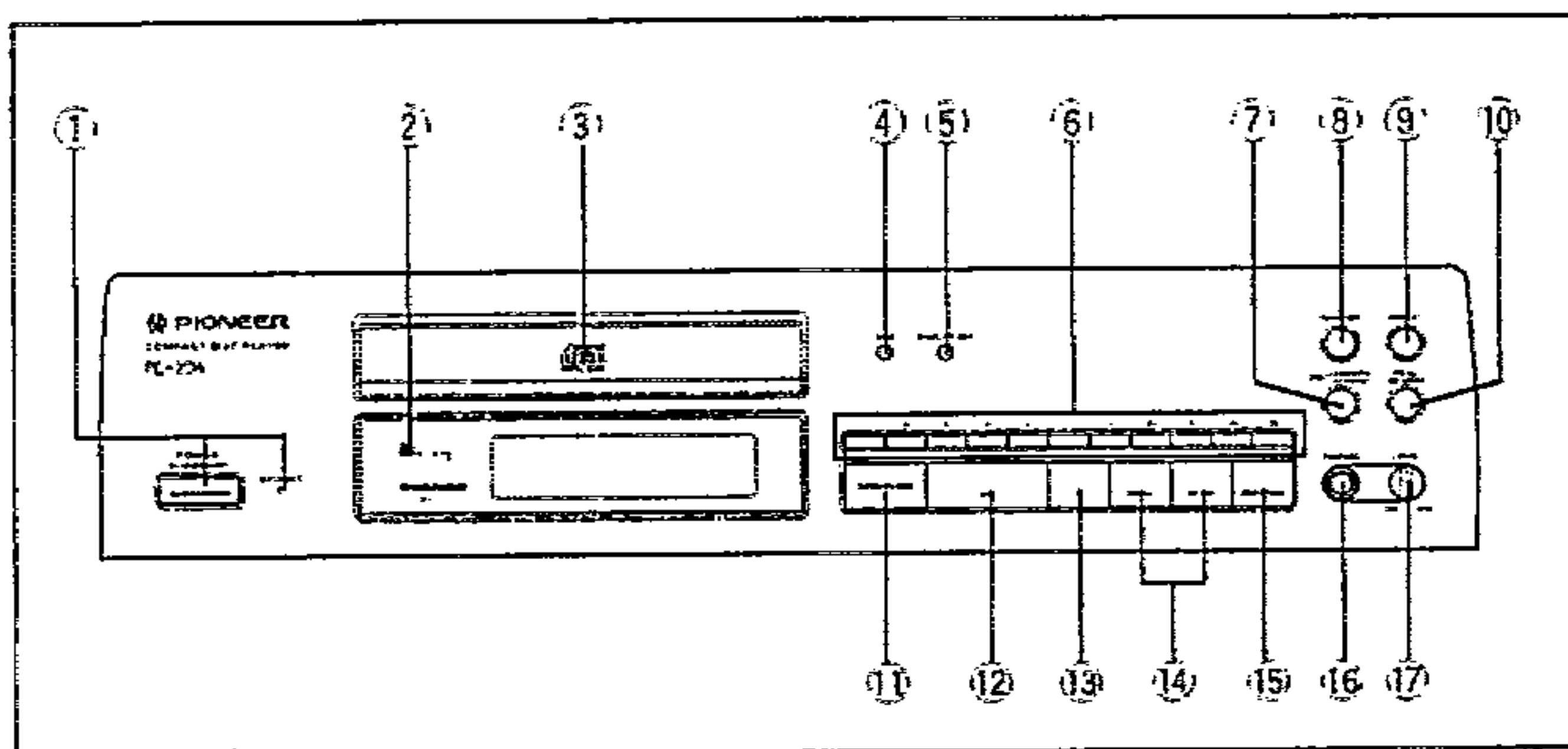

FRONT PANEL

- ① **POWER STANDBY/ON switch and STANDBY indicator**
- ② **Remote sensor**
Receives the signal from the remote control unit.
● The PD-104 is not equipped with the remote sensor.
- ③ **Disc tray**
- ④ **TIME button**
- ⑤ **DISPLAY OFF button**
- ⑥ **Digit buttons**
(1 - 10, >10)
- ⑦ **COMPU/AUTO EDIT button**
- ⑧ **RANDOM button**
- ⑨ **REPEAT button**
- ⑩ **PEAK SEARCH button**
- ⑪ **OPEN/CLOSE button (▲)**
- ⑫ **Play/Pause button (▶/||)**
- ⑬ **Stop button (■)**
- ⑭ **Track/Manual search buttons**
(◀◀ ◀/▶▶ ▶▶)
- ⑮ **PROGRAM button**
- ⑯ **Headphones jack (PHONES)**
- ⑰ **Headphones volume control (LEVEL)**

10. SPECIFICATIONS

1. General

Type	Compact disc digital audio system
Power requirements	AC 220 - 240 V, 50/60 Hz
Power consumption	12 W
Operating temperature	+5°C - +35°C
Weight	3.1 kg
External dimensions	420(W) X 101(H) X 267(D) mm

2. Audio section

Frequency response	2 Hz - 20 kHz
S/N ratio	102 dB or more (EIAJ)
Dynamic range	96 dB or more (EIAJ)
Harmonic distortion	0.003% or less (EIAJ)
Output voltage	2.0 V (EIAJ)
Wow and flutter	Limit of measurement (±0.001% W.PEAK) or less (EIAJ)
Channels	2-channel (stereo)

3. Output terminal

Audio line output jacks
Control input/output jacks (available with the PD-104)
CD-DECK SYNCHRO jack
Headphones jack (with volume control)

4. Accessories

● Remote control unit (PD-204 only)	1
● AAA/R03 dry cell batteries (PD-204 only)	2
● Control cable (PD-104 only)	1
● Output cable	1
● Operating instructions	1
● Warranty Card	1

NOTE:

Specifications and design subject to possible modification without notice, due to improvements.