

RXD-251/301/301E/301W/
351/351E/351W/371S/A3

SERVICE MANUAL

(XD-251~A3)**

© 1998-7/B51-5454-00 (K/K) 3763

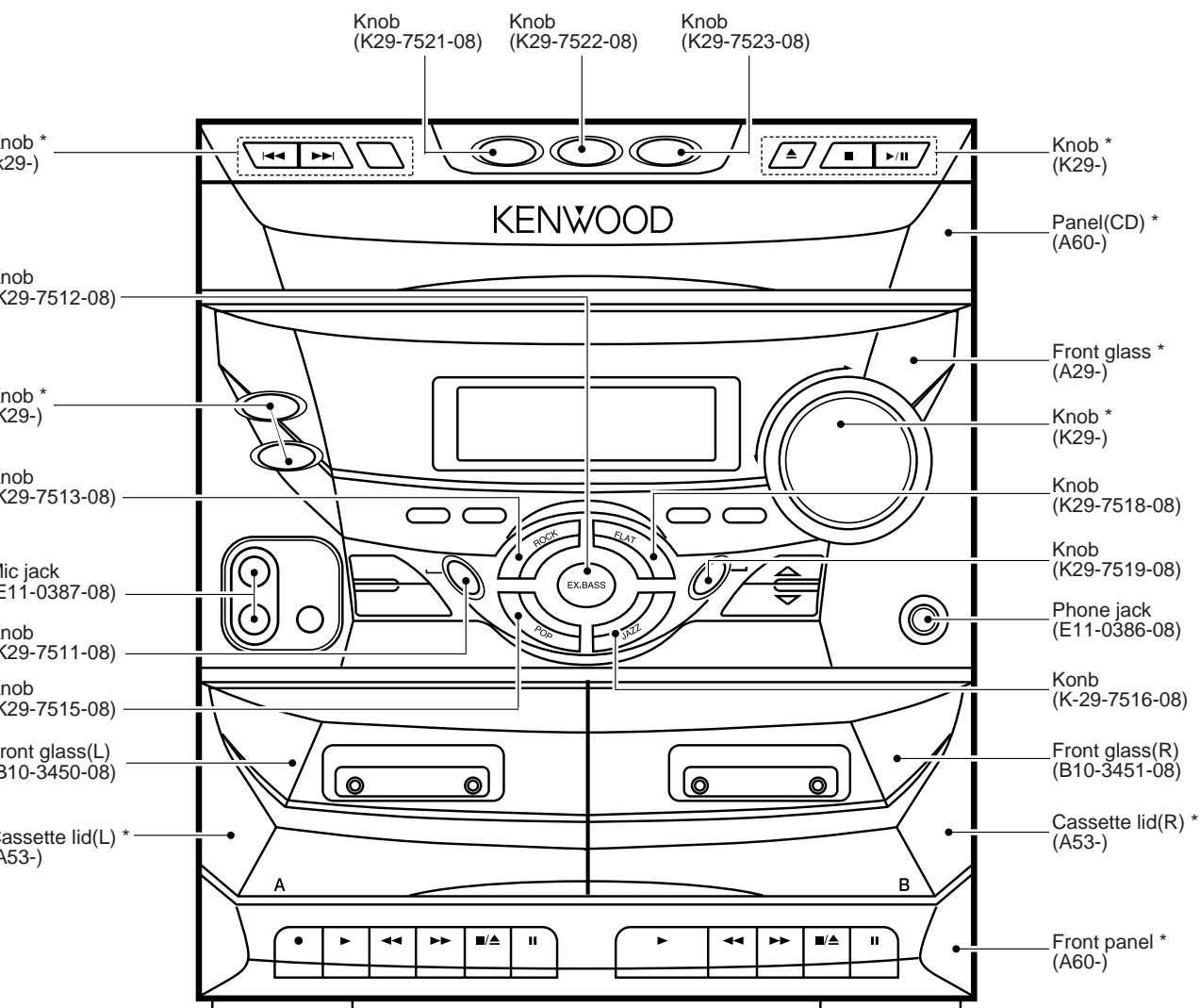

Illust. is RXD-351.

* Refer to parts list on page 38.

Refer to page 2 if you want to know system configuration.

In compliance with Federal Regulations, following are reproductions of labels on, or inside the product relating to laser product safety.

KENWOOD-Corp. certifies this equipment conforms to DHHS Regulations No. 21 DFR 1040. 10, Chapter 1, Subchapter J.

DANGER : Laser radiation when open and interlock defeated. AVOID DIRECT EXPOSURE TO BEAM

CONTENTS / ACCESSORIES

Contents

CONTENTS / ACCESSORIES	2	WIRING DIAGRAM	15
FRONT VIEW	3	PARTS DESCRIPTIONS	16
CONTROLS	4	PC BOARD	17
WIRING DIAGRAM	6	SCHEMATIC DIAGRAM	23
UNIT DESCRIPTION	7	EXPLODED VIEW	37
Mechanism Operation Description	9	PARTS LIST	38
ASSEMBLY	11	SPECIFICATIONS	47

Accessories

FM indoor antenna (1)

Europe and U.K.
(T90-0836-05)
E1E2E3E4T1T2Q1Q2

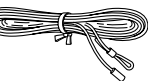

Other countries
(T90-0801-05)
: K1P1Y1M1M2M3X1X2X3



AC plug adaptor (1)
(E03-0115-05)

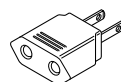

Use to adapt the plug on the power cord to the shape of the wall outlet.
(Accessory only for regions where use is necessary.)

Batteries (R6/AA) (2)

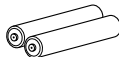

AM loop antenna (1)
(T90-0815-08)

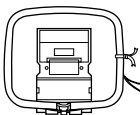

Remote control unit (1)
(A70-1260-08)

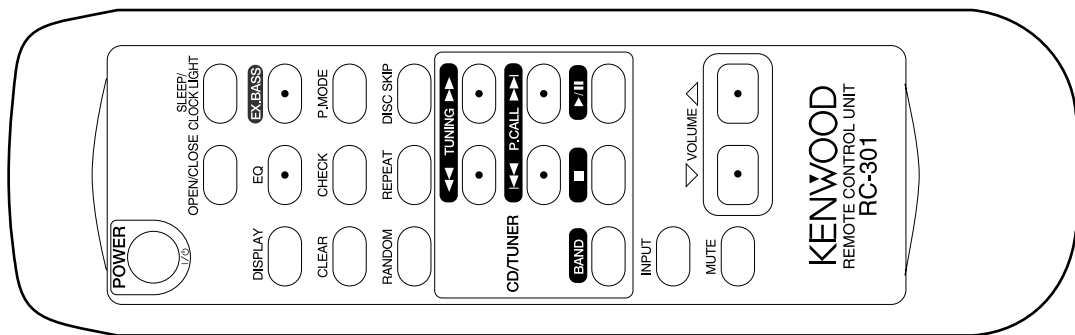

System configuration

ITEM	MAIN UNIT	DESTINATION	SPEAKER
01	RXD-301	E3T2X3	LS-N301
01E	RXD-301E	E4	LS-N301
01W	RXD-301W	Q2	LS-N301
01	RXD-351	E1T1	LS-N351
01	RXD-351	M1X1Y1	LS-N371
01E	RXD-351E	E2	LS-N351
01W	RXD-351W	Q1	LS-N351
03	RXD-A3	K1P1	LS-N351
01S	RXD-371S	M2	LS-N371
01	RXD-251	M3X2	LS-N351

Cautions

Operation to reset

The microcomputer may fall into malfunction (impossibility to operate, erroneous display, etc.) when the power cord is unplugged while power is ON or due to an external factor. In this case, execute the following procedure to reset the microcomputer and return it to normal condition.

Press the "POWER" key while holding the Stop (■) key of the CD section pressed, to switch off the power, and then switch the power on again after a few seconds.

- Please note that resetting the microcomputer clears the contents stored in and returns and to condition when it left the factory.

RXD-251/301/351/371S/A3

EXTERNAL VIEW

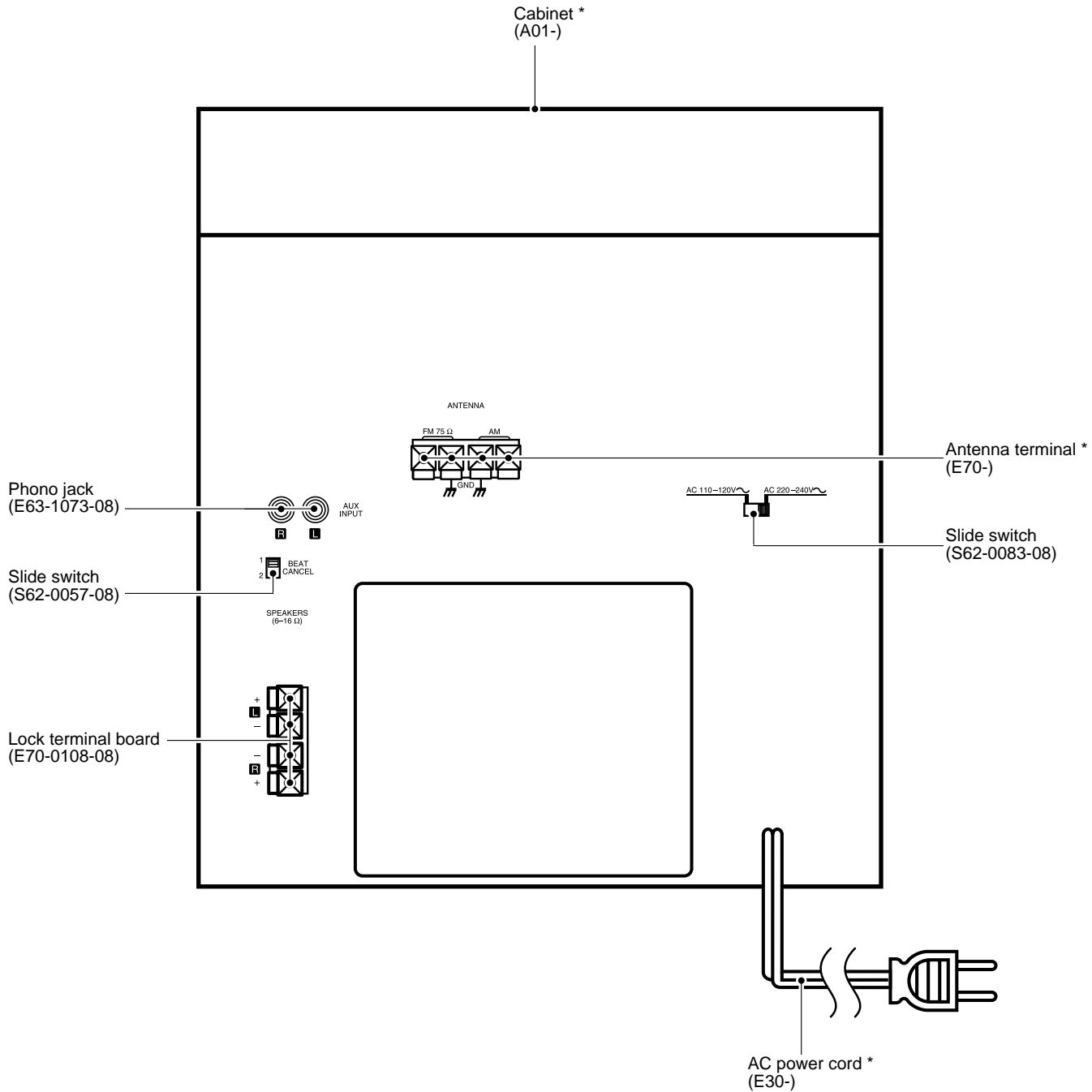

Illust. is RXD-351.

* Refer to parts list on page 38.

CONTROLS

unit

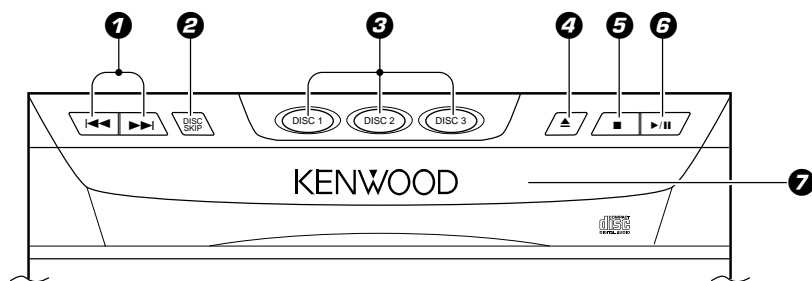

(←, →) keys

SKIP key

to skip discs.

selection keys

disc number is selected directly and playback starts.

4 OPEN/CLOSE (▲) key

The disc tray is opened and closed.

5 Stop (■) key

6 Play/pause (▶/||) key

7 Disc tray

Three discs can be stored.

Receiver unit

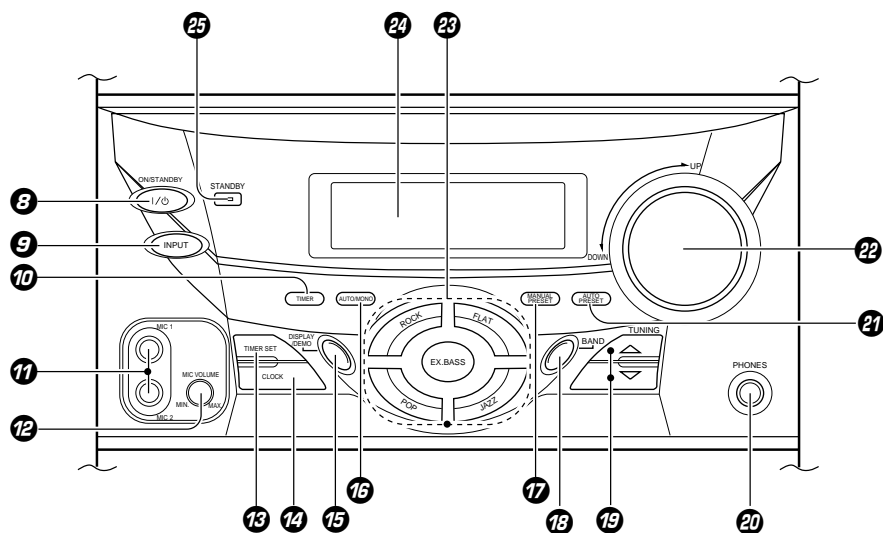

STANDBY (1/φ) key

T key

for input switching.

R key

for timer START/STOP switching.

1/MIC 2 jack (except for some areas)

VOLUME knob (except for some areas)

R SET key

for setting the timer ON/OFF time.

CK key

to set the present time.

LAY/DEMO key

changes the display contents.

D for demonstration (DEMO) ON/OFF.

MONO key

changes the tuning mode.

DUAL PRESET key

to memorize broadcasting stations in the desired order.

D key

to switch the receiving band.

19 TUNING/Δ∇ keys

Used for tuning to broadcasting stations and for time settings.

20 PHONES terminal

For connection of a headphone (optional).

21 AUTO PRESET key

Used for automatic presetting of broadcasting stations.

22 VOLUME CONTROL knob

This is used for volume adjustment.

23 Sound selection keys

Used to select the desired sound type.

FLAT : For listening without changing the sound.

JAZZ : A sound quality curve suitable for jazz.

POP : A sound quality curve suitable for popular music.

ROCK : A sound quality curve suitable for rock-and-roll.

EX. BASS : For listening with abundant bass. (Can be used together with other sound selection keys.)

24 Display

25 STANDBY indicator (Except for some areas)

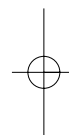

CONTROLS

Cassette deck unit

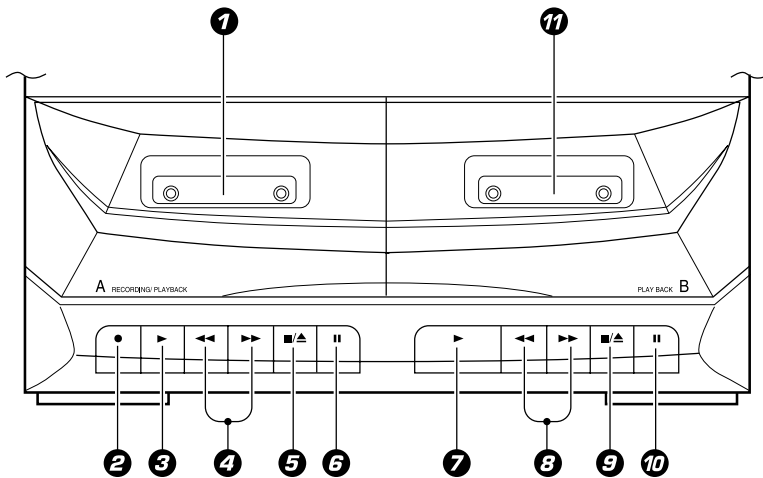

A deck

Cassette holder

Press the key to remove and insert the tape.

REC (●) key

Play (▶) key

Fast forward and rewind (◀◀, ▶▶) keys

Stop/Eject (■/▲) key

Pause (||) key

B deck

▶ Play (▶) key

◀◀ Fast forward and rewind (◀◀, ▶▶) keys

■/▲ Stop/Eject (■/▲) key

|| Pause (||) key

11 Cassette holder

Press the key to remove and insert the tape.

Display

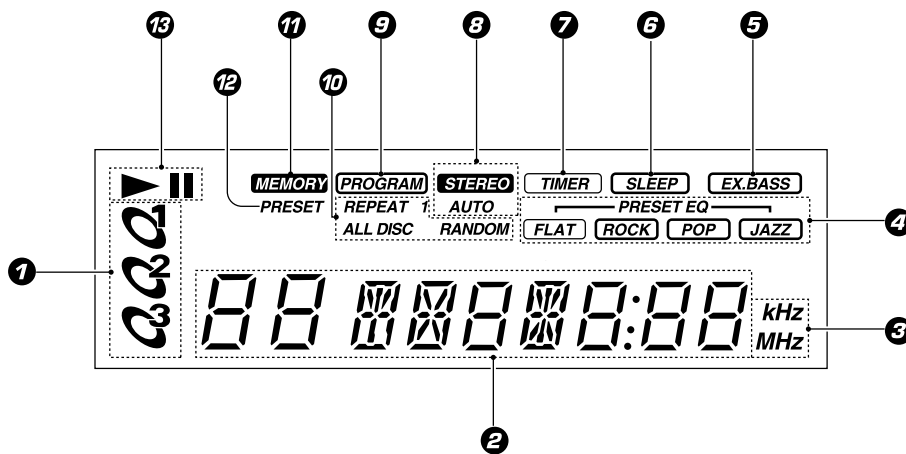

Disc display

When CD is selected, the numbers for which a disc has been set light.

Letter and number display

Title number, playback time, present time, etc. are displayed.

Reception frequency unit indication (kHz/MHz)

Sound selection indication

Extra bass (EX.BASS) indication

Sleep timer (SLEEP) indication

Timer (TIMER) indication

STEREO/AUTO indication

Indication of the reception mode for stereo broadcasts

PROGRAM indication

Lights at the time of program mode.

Repeat/Random mode indication

MEMORY indication

Shows when a broadcasting station is memorized.

PRESET indication

▶ Playback (▶), || Pause (||) indication

TUNER UNIT

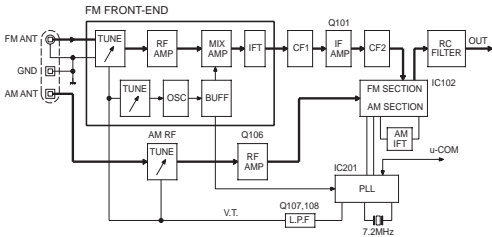

TUNER UNIT

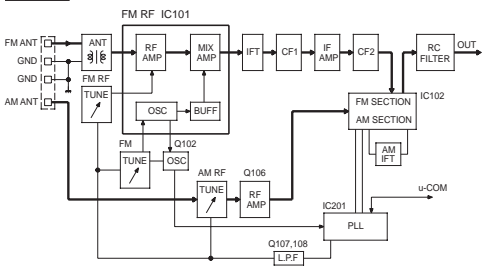

CD MECHA. UNIT

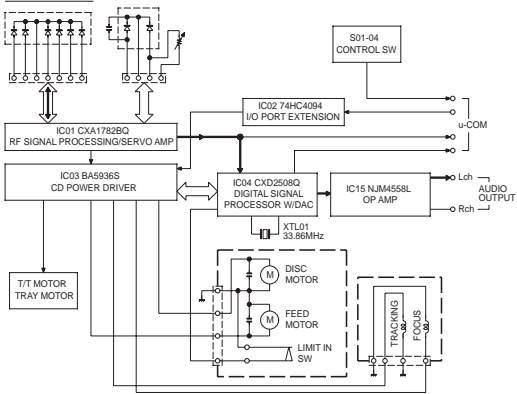

AUDIO UNIT/DISPLAY UNIT

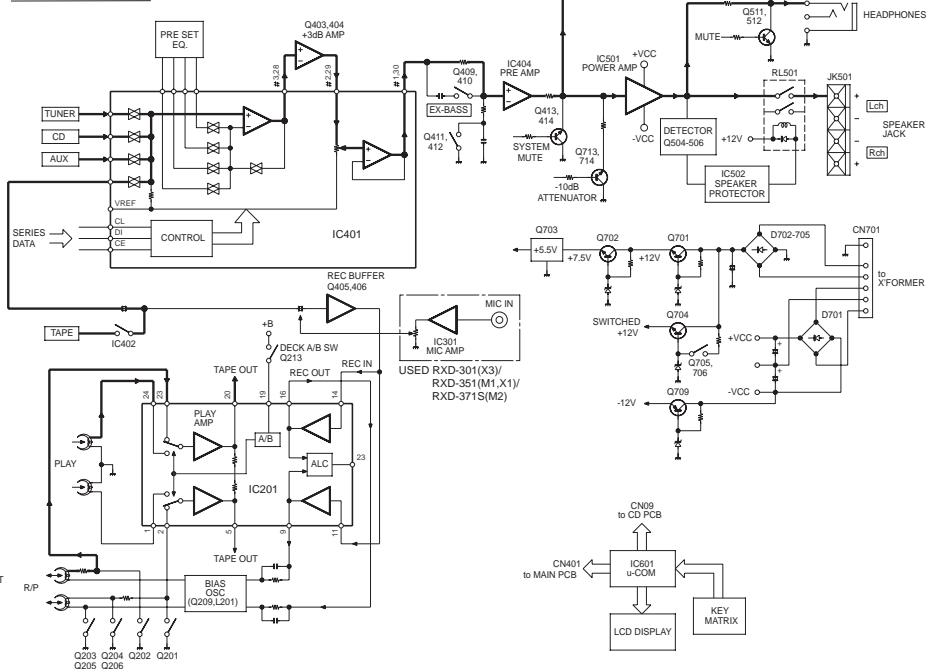

RXD-351

RXD-251/301/351/371S/A3

CIRCUIT DESCRIPTION

Microprocessor : (IC601, LC867224A-5H71)

Pin description

No.	Name	I/O	Description	Active	
				H	L
1	CE	I	LC7218, LC75392 CE out		
2	ENABLE	-	No used		
3	DI	I	LC7218, LC75392, 74HC4094 data out		
4	DO	O	Data output to LC7218		
5	CLK	I	LC 7218, LC75392, 74HC4094 clock out		
6	DATA	O	Serial data out to CXD2508Q		
7	SQCO	I	Serial output of SUBQ 80BIT		
8	SQCK	O	Clock output		
9	XLAT	O	Latch output		
10	FOK	O	Focus OK output		
11	GND	-	GND		
12	RESET	I	Reset signal input		
13	POWER - DOWN	I	Power down input		
14	SENS	I	CXD2508Q sens		
15	VSS	-	Vss		
16	X1	-	Xtal 6.0MHz		
17	X2	-	Xtal 6.0MHz		
18	VDD1	-	Vdd		
9~22	K1~K4	I	Key input (K1~K4)		
3, 24	GND	-	GND		
25	MODE - SW2	I	Model discrimination (RXD-371S only)		
26	MODE - SW1	I	Model discrimination		
27	SCOR	I	CXD2508Q Sub - code synch detect		
28	COUNT	O	Track number count signal output		
29	REMOTE IN	I	Remote signal input		
30	VR +	I	VR encoder input A		
31	VR -	I	VR encoder input B		
32	PIC - UP	I	Pick - up SW		
33	PIC - DOWN	I	Pick - down SW		
34	DISC - COUNT	I	Disc counter SW		
35	TURNTABLE - SW	I	Turntable SW		
36	TRAY - OPEN	I	Tray open SW		
37	TRAY - CLOSE	I	Tray close SW		
38	N/C	-	No used		
39	VR - 1	O	VR step extend out	0, 1 step	others
0~51	N/C	-	No used		
2~55	S1 - S4	O	Segment out (1~4)		
56	VDD2	-	Vdd		
57	VSS2	-	Vss		
8~79	S5~S26	O	Segment out (5~26)		
0~82	BIAS 3~1	-	GND		
3~86	COM - 0~3	O	FL Common 0~3		
87	FM - STEREO	I	FM stereo signal input	Mono	Stereo
88	SYN REC	I	Synchro start input		
89	VSS3	-	Vss		

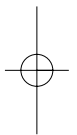

CIRCUIT DESCRIPTION

	Name	I/O	Description	Active	
				H	L
	VDD3	-	Vdd		
	POWER - SW	O	Power SW out	On	Off
	SYS - MUT	O	System mute out	Off	On
	TU - MUT	O	Tuner mute out	On	Off
	MODE - SW - IN	I	No used		
	FUNCTION - TAPE	O	Function tape out	Tape	Others
	LCD - BACK - LIGHT	O	LCD back light control	On	Off
	N/C	-	No used		
	EX - BASS	O	EX - bass control	On	Off
	LATCH	-	No used		
	STB	O	74HC4094 strobe		

Key matrix

	SW 1	SW 2	SW 3	SW 4	SW 5	SW 6	SW 7	SW 8	SW 9	SW 10
	Power	Input	Clock Set	Timer Mode	Timer Set	Display	EQ Off	Rock	Jazz	Pop
	Tuning Up	Tuning Down	Band	Auto/Mono	Auto Preset	Manual Preset	EX Bass	-	-	-
	CD AMS +	AMS -	-	-	Disc Skip	Disc 1	Disc 2	Disc 3	Open Close	-
	CD Stop	CD Play Pause	FF	-	-	-	-	-	-	-



Port extension (CD mecha. unit)

2 (74HC4094)

	NAME	I/O	DESCRIPTION	ACTIVE
	MUTE	O	CXD2508Q Muting (DAC)	H : ON L : OFF
	CONTROL	O	CXA1782BQ, CXD2508Q Vdd control	H : Others L : CD
	XRST	O	CXD2508Q XRST	
	T • T +	O	T • T/U • D Motor (+)	
	CONTROL	O	T • T Motor speed Control	
	TRAY -	O	Tray Motor Control (-)	
	TRAY +	O	Tray Motor Control (+)	
	T • T -	O	T • T/U • D Motor (-)	

LCD light on mode

All LCD light up when the STOP key and TIMER SET key are pressed simultaneously, while the power is ON. When the ON/STANDBY key is pressed, the all LCD light on mode is canceled.

CD MECHANISM OPERATION DESCRIPTION

Open case of disc 3 (Refer to figure 1 and 2)

The rotary motor turns counterclockwise by pressing disc 3 key, therefore the turntable turns clockwise and disc 3 is detected by disc number detector switch.

The turntable stops the position of ► marked as figure 2 and stop position of disc 3 is detected by sensor switch.

At this time, the position of TR lock gear is as shown figure 1.

The rotary motor turns clockwise and the relay gear B also turns clockwise.

By turning the relay gear B, the arm of relay gear B moves to arrow direction (◀ ■ ■ ■) and the TR lock gear will be locked.

After that, the change gear separates from TR lock gear.

The UD reduce gear turns clockwise by turning the change gear.

The traverse moves up-side.

After finished the traverse operation, the disc motor turns and the disc 3 will be played.

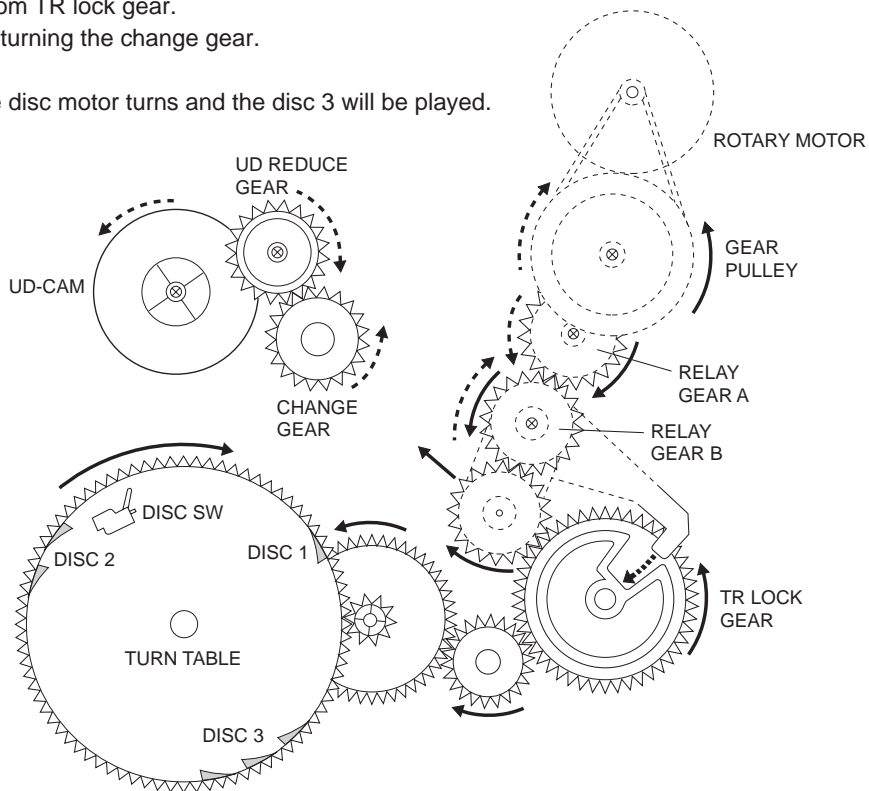

Fig.1

Open/Close operation of tray while playing the disc.

(Refer to figure 3)

The tray motor turns clockwise by pressing open/close key while playing the disc.

The change base moves to frontward by turning the TR gear.

Pushing switch C by change base, the tray motor stops.

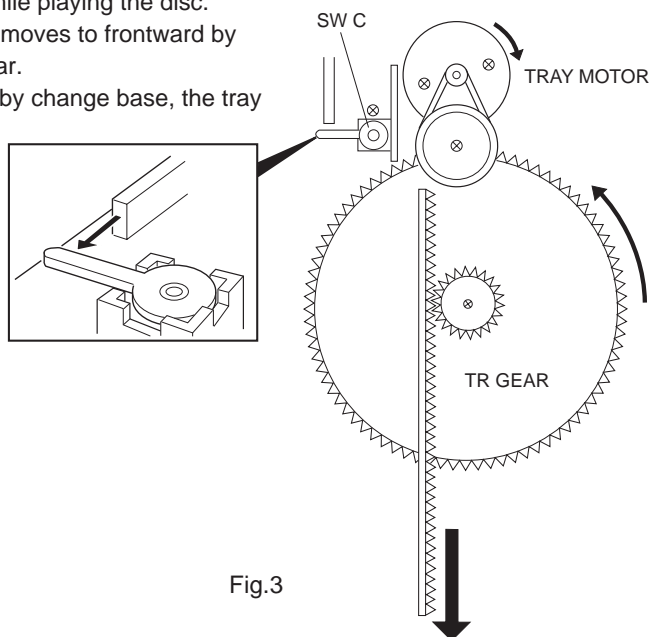

Fig.3

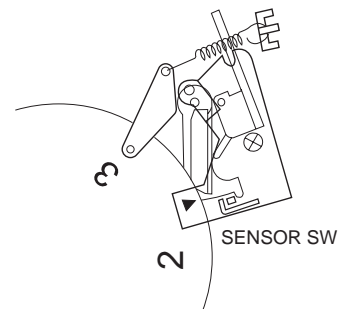

Fig.2
(STOP POSITION OF DISC 3)

CD MECHANISM OPERATION DESCRIPTION

How to replace the pick up. (Refer to figure 4~7)

Remove the screws (① x 4), top chassis and spring (② x 2).

Remove the traverse unit by removing shield (bottom side) and screws (③ x 2).

Remove the short land and remove screws (④ x 4, ⑤ x 1).

Remove the rod and replace the pick up.

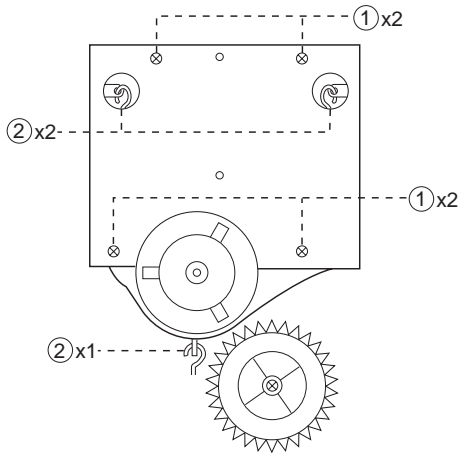

Fig.4

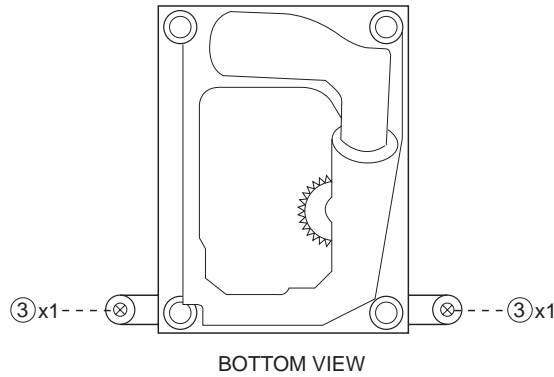

Fig.5

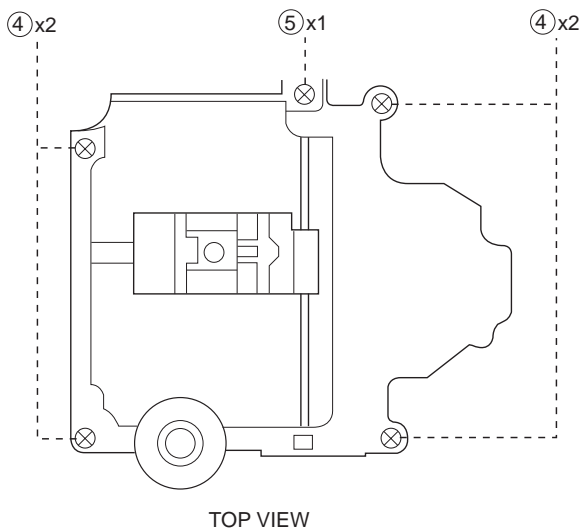

Fig.6

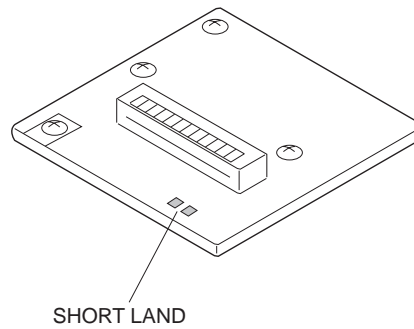
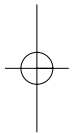

Fig.7



RXD-251/301/351/371S/A3

ADJUSTMENT

FM SECTION (Except for Europe version)

Europe version no Adjustment

NO.	ITEM	INPUT SETTING	OUTPUT SETTING	TUNER SETTING	ALIGNMENT POINTS	ALIGN FOR	FIG.
1.	IF	(A) 98 MHz, 1 kHz MOD ±75 kHz (DEV) 60 dBu (ANT INPUT)	(B)	98MHz	T101	Maximum output (Minimum distortion)	
2.	LOWEND TRACKING	(A) 87MHz, 1 kHz MOD ±75 kHz (DEV) 35 dBu (ANT INPUT)	(B)	87MHz	L102	Maximum output	
3.	HIEND TRACKING	(A) 108MHz, 1 kHz MOD ±75 kHz (DEV) 35 dBu (ANT INPUT)	(B)	108MHz	TC101	Maximum output	
4.	VT	-	Connect the DC voltage meter to TP2.	87.5 MHz	L103	VT=1.0V±0.05V	
				108 MHz	-	Check the VT=7.0V±1.0V	

MW SECTION

NO.	ITEM	INPUT SETTING	OUTPUT SETTING	TUNER SETTING	ALIGNMENT POINTS	ALIGN FOR	FIG.
1.	IF	(A) 531 kHz or 530 kHz 1 kHz, 30% MOD 60 dBu (ANT INPUT)	(B)	531 kHz or 530 kHz	T102	Maximum output (Minimum distortion)	
2.	LOWEND TRACKING	(A) 531 kHz or 530 kHz 1 kHz, 30% MOD 30 dBu (ANT INPUT)	(B)	531 kHz or 530 kHz	L104	Maximum output	
3.	HIGHEND TRACKING	(A) 1602 kHz or 1610 kHz 1 kHz, 30% MOD 30 dBu (ANT INPUT)	(B)	1602 kHz or 1610 kHz	TC102	Maximum output	
4.	VT	-	Connect the DC voltage meter to TP2.	531 kHz	L105	VT=1.2V±0.05V	
				1602 kHz	-	Check the VT=7.3V±1.0V	

SW SECTION

NO.	ITEM	INPUT SETTING	OUTPUT SETTING	TUNER SETTING	ALIGNMENT POINTS	ALIGN FOR	FIG.
1.	IF	5.95 MHz 1 kHz, 30% MOD 60 dBu (ANT INPUT) (D)	(B)	5.95 MHz	T102	Maximum output (Minimum distortion)	
2.	LOWEND TRACKING	5.95 MHz 1 kHz, 30% MOD 30 dBu (ANT INPUT) (D)	(B)	5.95 MHz	L201	Maximum output	
3.	HIGHEND TRACKING	17.9 MHz 1 kHz, 30% MOD 30 dBu (ANT INPUT) (D)	(B)	17.9 MHz	TC201	Maximum output	
4.	VT	-	Connect the DC voltage meter to TP2.	5.95 MHz	L202	VT=1.0V±0.05V	
				17.9 MHz	-	Check the VT=8.4V±1V	

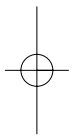

ADJUSTMENT

SECTION

ITEM	INPUT SETTING	OUTPUT SETTING	TUNER SETTING	ALIGNMENT POINTS	ALIGN FOR	FIG.
IF	153 kHz 1 kHz, 30% MOD 60 dBu (ANT INPUT) (D)	(B)	153 kHz	T102	Maximum output (Minimum distortion)	
LOWEND TRACKING	153 kHz 1 kHz, 30% MOD 30 dBu (ANT INPUT) (D)	(B)	153 kHz	L201	Maximum output	
HIGHEND TRACKING	279 kHz 1 kHz, 30% MOD 30 dBu (ANT INPUT) (D)	(B)	279 kHz	TC201	Maximum output	
VT	-	Connect the DC voltage meter to TP2.	153 kHz	L202	VT=1.0V±0.05V	
			279 kHz	-	Check the VT=5.0V±1.0V	

INSTRUMENTS CONNECTION

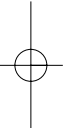
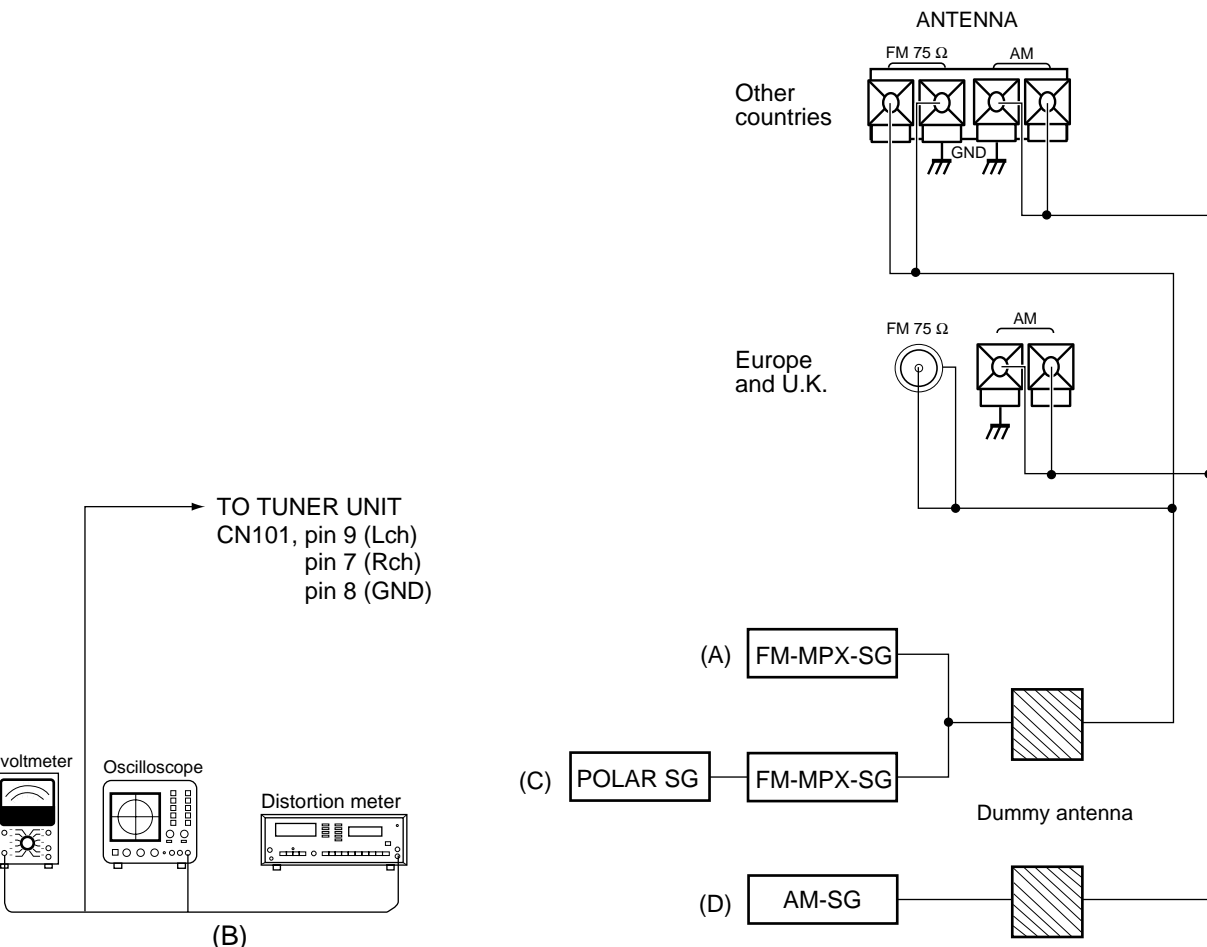

RXD-251/301/351/371S/A3

ADJUSTMENT

CASSETTE DECK SECTION

ITEM	INPUT SETTINGS	OUTPUT SETTINGS	CASSETTE TAPE DECK SETTINGS	ALIGNMENT POINT	ALGN FOR	FIG
Unless otherwise specified : each ; switch should be set as follows : REPEAT SW : OFF Cassette mechanism section (REC/PB head adjustment)						0dBs = 0.775V
Demagnetization and cleaning	-	-	Power OFF, demagnetization, cleaning play	REC/PB head, erase head, capstan, pinch roller	Demagnetize the REC/PB head by head eraser. Clean the REC/PB head, erase head capstan and pinch roller with a cotton swab immersed in alcohol.	
REC/PB head azimuth	MTT-114, TCC-153 SCC-1727 10 kHz, -10dB	(A)	PLAY	Azimuth adjustment screw	In a setting when the output is maximized, adjust the azimuth adjustment screw so that the Lissajous figure appearing on the oscilloscope screen comes near to a line slanted 45°. Note : The head should be installed in such a manner that it approaches the tape face.	
PC board adjustment						
Tape speed	MTT-111 TCC-100 SCC-1727 3 kHz, -4 dB	(A)	PLAY	SFR201	Adjust so that Frequency is 3 kHz at the center of the tape.	
Playback level	TCC-120 315 Hz 0dB	(A)	PLAY		Approx. -5dBm ※ reference level	
Recording level	Put standard test tape (TCC-120) into B deck. Put standard blank tape into A deck.	(A)	Dubbing and playback.		Approx. -5dBm ※ reference level	

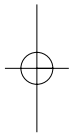

INSTRUMENTS CONNECTION

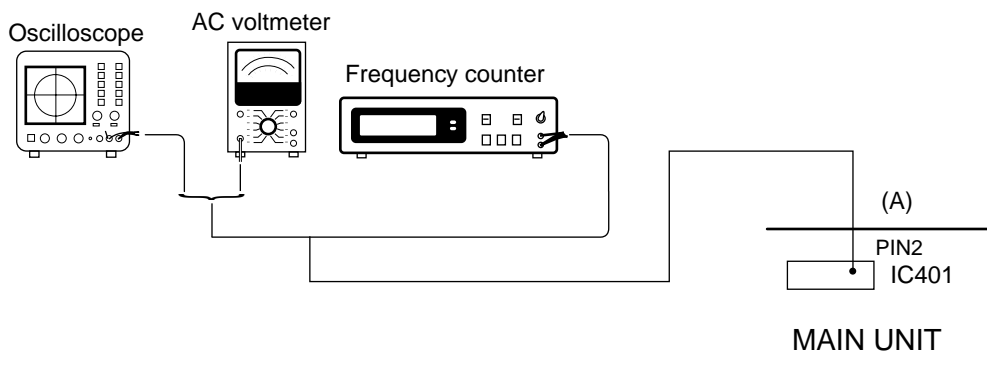

ADJUSTMENT

ADJUSTMENT ACTION

ITEM	INPUT SETTINGS	OUTPUT SETTINGS	PLAYER SETTINGS	ALIGNMENT POINTS	ALIGN FOR	FIG.
LASER POWER	-	Apply the sensor section of optical power meter on the pickup lens.	Press the PLAY/PAUSE key.	-	On the power from 0.08 to 0.15 mW, when the diffraction grating is correctly aligned with the RF level of 0.6 Vp-p or more.	(a)
FOCUS ERROR BIAS	Test disc Type 4	Connect an oscilloscope as follows. CH1 : RF (R07A) GND : VC (IC01, 48 pin)	Press the PLAY/PAUSE key.	FE BIAS VR01	Optimum eye pattern	

Test disc : SONY YEDS-18 Test Disc or equivalent.(KTD-0*)

LASER POWER

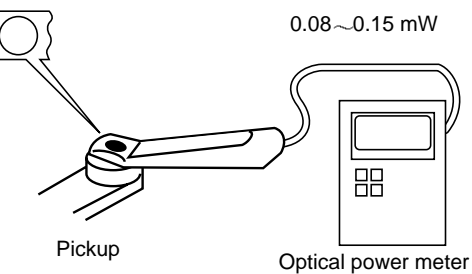

ALIGNMENT POINT

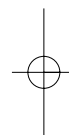
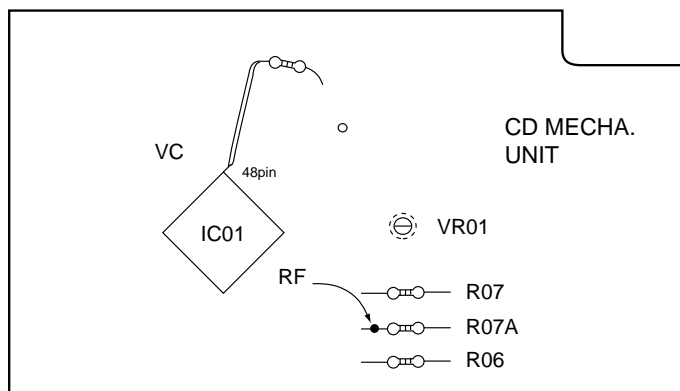

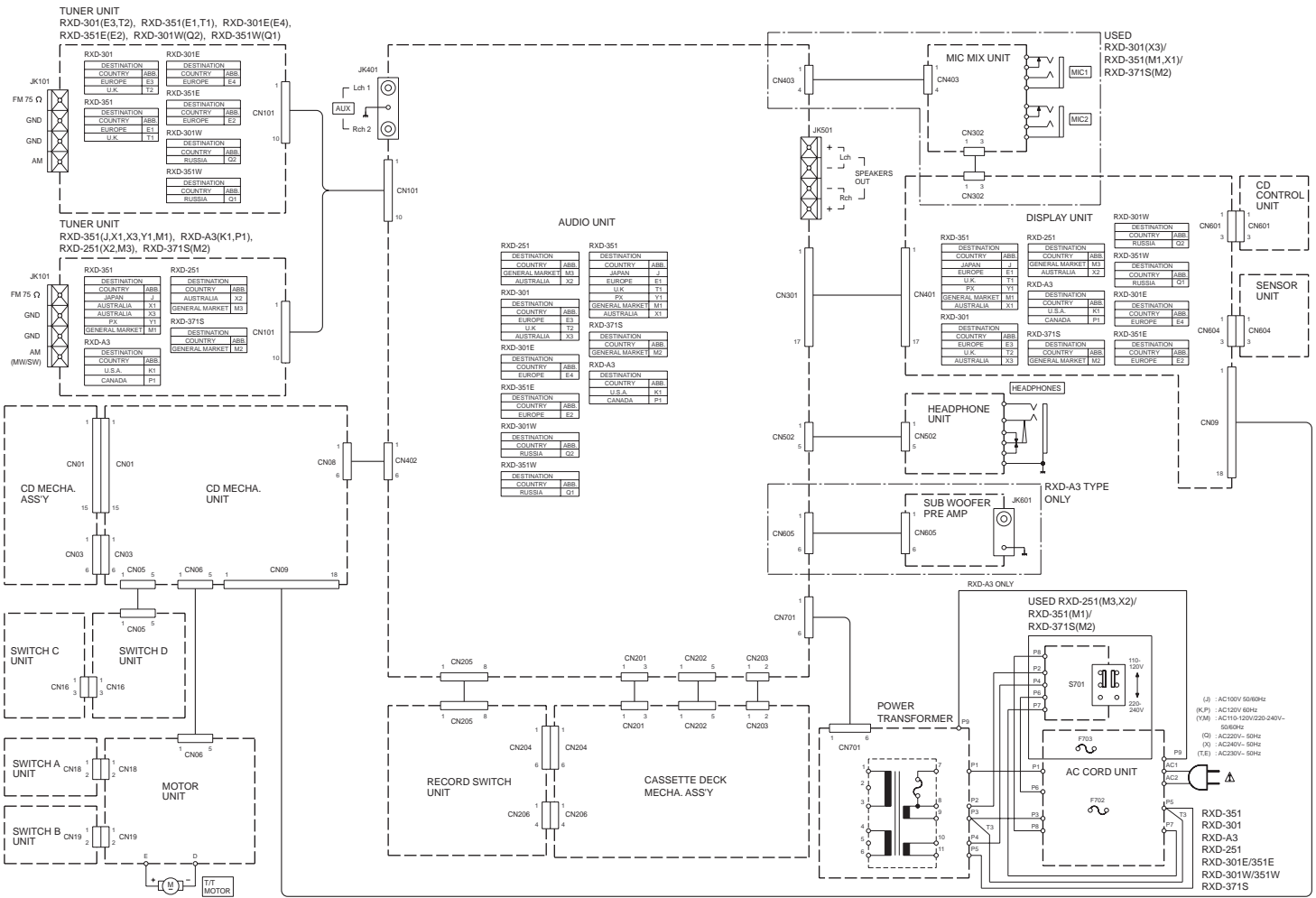

WIRING DIAGRAM

RXD-251/301/351/371S/A3

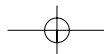

PARTS DESCRIPTIONS

CAPACITORS

CC 45 TH 1H 220 J
 1 2 3 4 5 6

... ceramic, electrolytic, etc. 4 = Voltage rating
 ... round, square, ect. 5 = Value
 ... temp. coefficient 6 = Tolerance

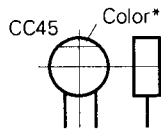

Capacitor value

010 = 1pF
 100 = 10pF
 101 = 100pF
 102 = 1000pF = 0.001μF
 103 = 0.01μF

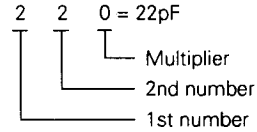

Temperature coefficient

2nd word	C	L	P	R	S	T	U
Color*	Black	Red	Orange	Yellow	Green	Blue	Violet
ppm/°C	0	-80	-150	-220	-330	-470	-750

2nd Word	G	H	J	K	L
ppm/°C	±30	±60	±120	±250	±500

Example : CC45TH = -470 ± 60ppm/°C

Capacitance (More than 10pF)

C	D	G	J	K	M	X	Z	P	No code
±0.25	±0.5	±2	±5	±10	±20	+40	+80	+100	More than 10μF - 10 ~ +50
						-20	-20	-0	Less than 4.7μF - 10 ~ +75

Capacitance (Less than 10pF)

Code	B	C	D	F	G
(pF)	±0.1	±0.25	±0.5	±1	±2

Capacitance rating

2nd word	A	B	C	D	E	F	G	H	J	K	V
0	1.0	1.25	1.6	2.0	2.5	3.15	4.0	5.0	6.3	8.0	-
1	10	12.5	16	20	25	31.5	40	50	63	80	35
2	100	125	160	200	250	315	400	500	630	800	-
3	1000	1250	1600	2000	2500	3150	4000	5000	6300	8000	-

Chip capacitors

CC 7 3 F S L 1 H 0 0 0 J
 1 2 3 4 5 6 7

(Chip) (CH, RH, UJ, SL)

CK 7 3 F F 1 H 0 0 0 Z
 1 2 3 4 5 6 7

(Chip) (B, F)

Refer to the table above.

- 1 = Type
- 2 = Shape
- 3 = Dimension
- 4 = Temp. coefficient
- 5 = Voltage rating
- 6 = Value
- 7 = Tolerance

Dimension (Chip capacitors)

Dimension code	L	W	T
Empty	5.6 ± 0.5	5.0 ± 0.5	Less than 2.0
A	4.5 ± 0.5	3.2 ± 0.4	Less than 2.0
B	4.5 ± 0.5	2.0 ± 0.3	Less than 2.0
C	4.5 ± 0.5	1.25 ± 0.2	Less than 1.25
D	3.2 ± 0.4	2.5 ± 0.3	Less than 1.5
E	3.2 ± 0.2	1.6 ± 0.2	Less than 1.25
F	2.0 ± 0.3	1.25 ± 0.2	Less than 1.25
G	1.6 ± 0.2	0.8 ± 0.2	Less than 1.0

Resistors

resistor (Carbon)

R K 7 3 E B 2 B 0 0 0 J
 1 2 3 4 5 6 7

(Chip) (B, F)

Normal resistor

R D 1 4 B B 2 C 0 0 0 J
 1 2 3 4 5 6 7

5 = Rating wattage
 6 = Value
 7 = Tolerance

Dimension

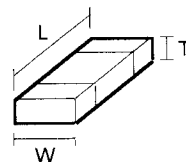

Dimension (Chip resistor)

Dimension code	L	W	T
E	3.2 ± 0.2	1.6 ± 0.2	1.0
F	2.0 ± 0.3	1.25 ± 0.2	1.0
G	1.6 ± 0.2	0.8 ± 0.2	0.5 ± 0.1

Rating wattage

Code	Wattage	Code	Wattage	Code	Wattage
1J	1/16W	2C	1/6W	3A	1W
2A	1/10W	2E	1/4W	3D	2W
2B	1/8W	2H	1/2W		

BOARD (Component side view)

TUNER UNIT : RXD-371S (M2)

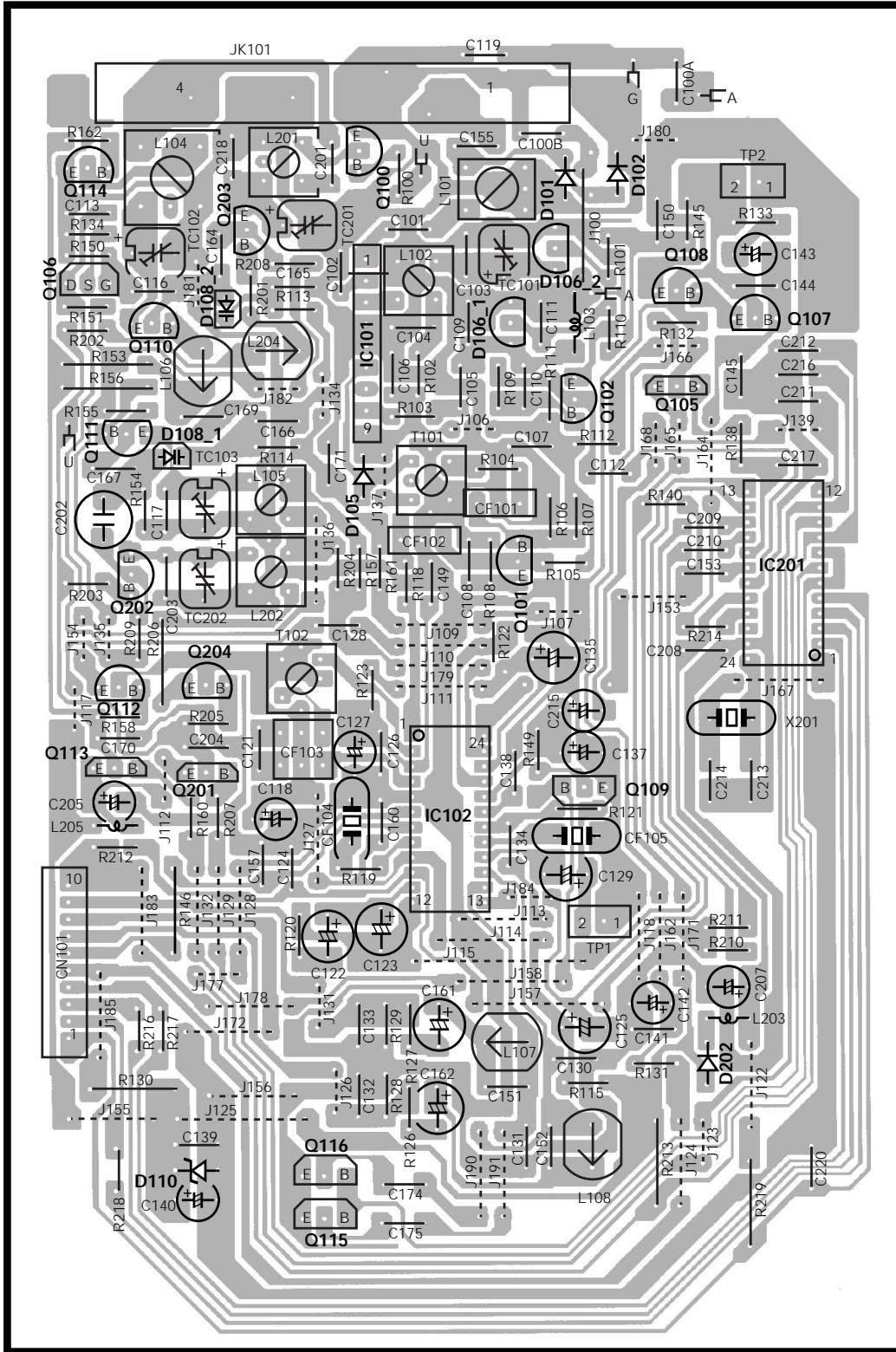

Refer to the schematic diagram for the value of resistors and capacitors.



PC BOARD (Component side view)

AUDIO UNIT

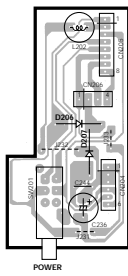
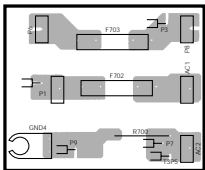
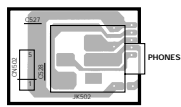
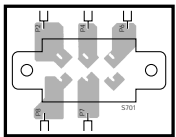
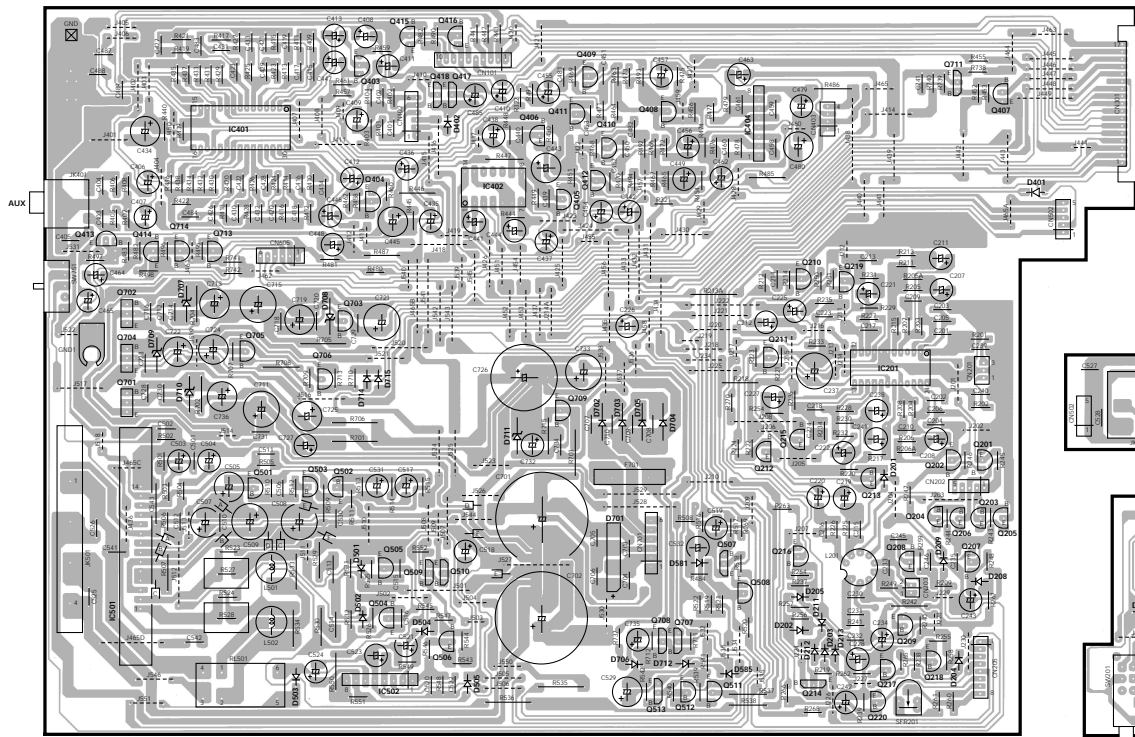

Refer to the schematic diagram for the value of resistors and capacitors.



BOARD (Component side view)

DISPLAY UNIT

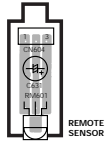
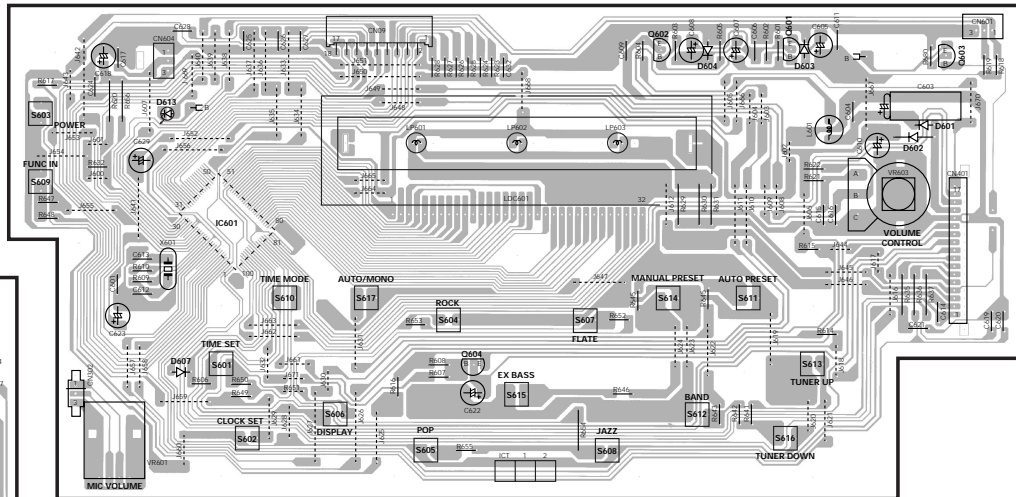
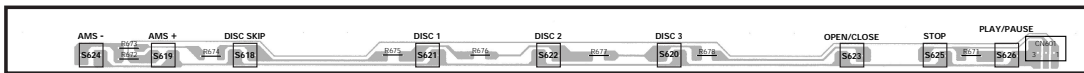

REMOTE SENSOR

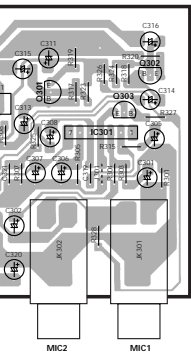

MIC2

MIC1

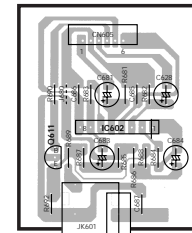

PHONES

TUNER UNIT RXD-3512(X1,Y1,M1), RXD-3011(P1), RXD-2510(M3), RXD-3718(M2)

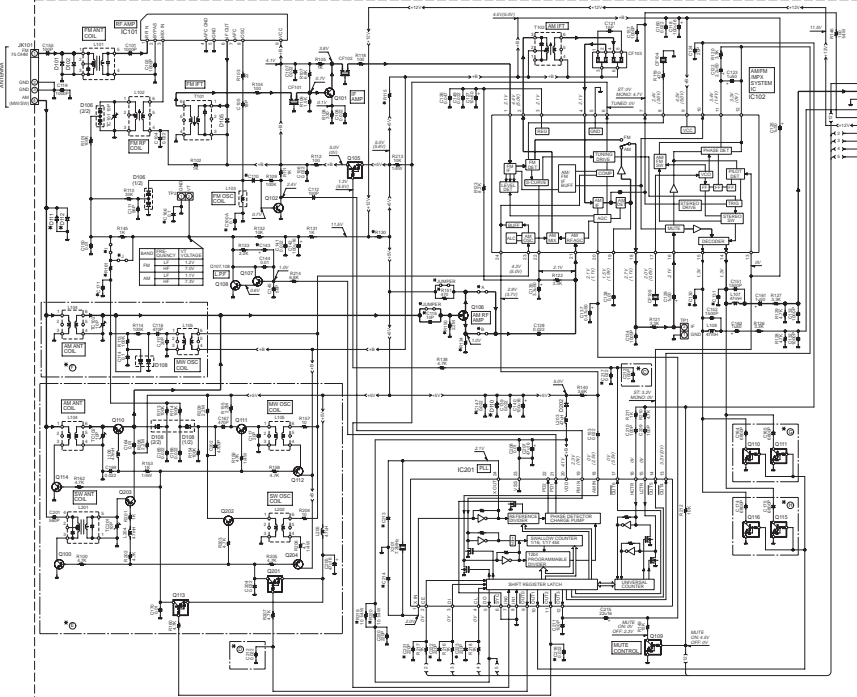

RXD-3011

ITEM	QTY	UNIT	DESCRIPTION	QTY	UNIT	DESCRIPTION	QTY	UNIT	DESCRIPTION	QTY	UNIT	DESCRIPTION	QTY	UNIT	DESCRIPTION	QTY	UNIT	DESCRIPTION
1	1	PCB	PCB	1	1	PCB	1	1	PCB	1	1	PCB	1	1	PCB	1	1	PCB

RXD-3512

ITEM	QTY	UNIT	DESCRIPTION	QTY	UNIT	DESCRIPTION	QTY	UNIT	DESCRIPTION	QTY	UNIT	DESCRIPTION	QTY	UNIT	DESCRIPTION	QTY	UNIT	DESCRIPTION
1	1	PCB	PCB	1	1	PCB	1	1	PCB	1	1	PCB	1	1	PCB	1	1	PCB

RXD-3718

ITEM	QTY	UNIT	DESCRIPTION	QTY	UNIT	DESCRIPTION	QTY	UNIT	DESCRIPTION	QTY	UNIT	DESCRIPTION	QTY	UNIT	DESCRIPTION	QTY	UNIT	DESCRIPTION
1	1	PCB	PCB	1	1	PCB	1	1	PCB	1	1	PCB	1	1	PCB	1	1	PCB

- IC101 : LA1800N
- IC102 : LA9201
- IC201 : LC7216
- Q101 : 2SC3234H
- Q102 : 2SC3234H
- Q103 : 2SA1915
- Q104 : 2SC3234H
- Q105 : 2SC3234H
- Q106 : 2SC3234H
- Q107 : 2SC3234H
- Q108 : 2SC3234H
- Q109 : 2SC3234H
- Q110 : 2SC3234H
- Q111 : 2SC3234H
- Q112 : 2SC3234H
- Q113 : 2SC3234H
- Q114 : 2SC3234H
- Q115 : 2SC3234H
- Q116 : 2SC3234H
- Q117 : 2SC3234H
- Q118 : 2SC3234H
- Q119 : 2SC3234H
- Q120 : 2SC3234H
- Q121 : 2SC3234H
- Q122 : 2SC3234H
- Q123 : 2SC3234H
- Q124 : 2SC3234H
- Q125 : 2SC3234H
- Q126 : 2SC3234H
- Q127 : 2SC3234H
- Q128 : 2SC3234H
- Q129 : 2SC3234H
- Q130 : 2SC3234H
- Q131 : 2SC3234H
- Q132 : 2SC3234H
- Q133 : 2SC3234H
- Q134 : 2SC3234H
- Q135 : 2SC3234H
- Q136 : 2SC3234H
- Q137 : 2SC3234H
- Q138 : 2SC3234H
- Q139 : 2SC3234H
- Q140 : 2SC3234H
- Q141 : 2SC3234H
- Q142 : 2SC3234H
- Q143 : 2SC3234H
- Q144 : 2SC3234H
- Q145 : 2SC3234H
- Q146 : 2SC3234H
- Q147 : 2SC3234H
- Q148 : 2SC3234H
- Q149 : 2SC3234H
- Q150 : 2SC3234H
- Q151 : 2SC3234H
- Q152 : 2SC3234H
- Q153 : 2SC3234H
- Q154 : 2SC3234H
- Q155 : 2SC3234H
- Q156 : 2SC3234H
- Q157 : 2SC3234H
- Q158 : 2SC3234H
- Q159 : 2SC3234H
- Q160 : 2SC3234H
- Q161 : 2SC3234H
- Q162 : 2SC3234H
- Q163 : 2SC3234H
- Q164 : 2SC3234H
- Q165 : 2SC3234H
- Q166 : 2SC3234H
- Q167 : 2SC3234H
- Q168 : 2SC3234H
- Q169 : 2SC3234H
- Q170 : 2SC3234H
- Q171 : 2SC3234H
- Q172 : 2SC3234H
- Q173 : 2SC3234H
- Q174 : 2SC3234H
- Q175 : 2SC3234H
- Q176 : 2SC3234H
- Q177 : 2SC3234H
- Q178 : 2SC3234H
- Q179 : 2SC3234H
- Q180 : 2SC3234H
- Q181 : 2SC3234H
- Q182 : 2SC3234H
- Q183 : 2SC3234H
- Q184 : 2SC3234H
- Q185 : 2SC3234H
- Q186 : 2SC3234H
- Q187 : 2SC3234H
- Q188 : 2SC3234H
- Q189 : 2SC3234H
- Q190 : 2SC3234H
- Q191 : 2SC3234H
- Q192 : 2SC3234H
- Q193 : 2SC3234H
- Q194 : 2SC3234H
- Q195 : 2SC3234H
- Q196 : 2SC3234H
- Q197 : 2SC3234H
- Q198 : 2SC3234H
- Q199 : 2SC3234H
- Q200 : 2SC3234H

CAUTION: For continued safety, replace safety critical components only with manufacturer's recommended parts (refer to parts list). **⚠** indicates safety critical components. For continued protection against risk of fire, replace only with same type and rating fuse(s). To reduce the risk of electric shock, leakage-current or resistance measurements shall be carried out (exposed parts are acceptably insulated from the supply circuit) before the appliance is returned to the customer.

The DC voltage is an actual reading measured with a high impedance type voltmeter as the AM/FM signal generator is specified to the conditions as shown in the list below. The measurement value may vary depending on the measuring instruments used or on the product. The value shown in () is actual reading measured in the AM mode.

MODE	CARRIER	MODULATION		ANT INPUT
		FREQUENCY	DEVIATION	
FM	88MHz	10Hz	STEREO 87.5kHz (P10k)	60dB
AM	1000/999kHz	40Hz	MONO 30% MOD	60dB

RXD-3512(X1,Y1,M1) (1/5)
 RXD-3011(P1) (1/5)
 RXD-2510(M3) (1/5)
 RXD-3718(M2) (1/5)

Y39-2930-11

RXD-251/301/351/371S/A3

KENWOOD

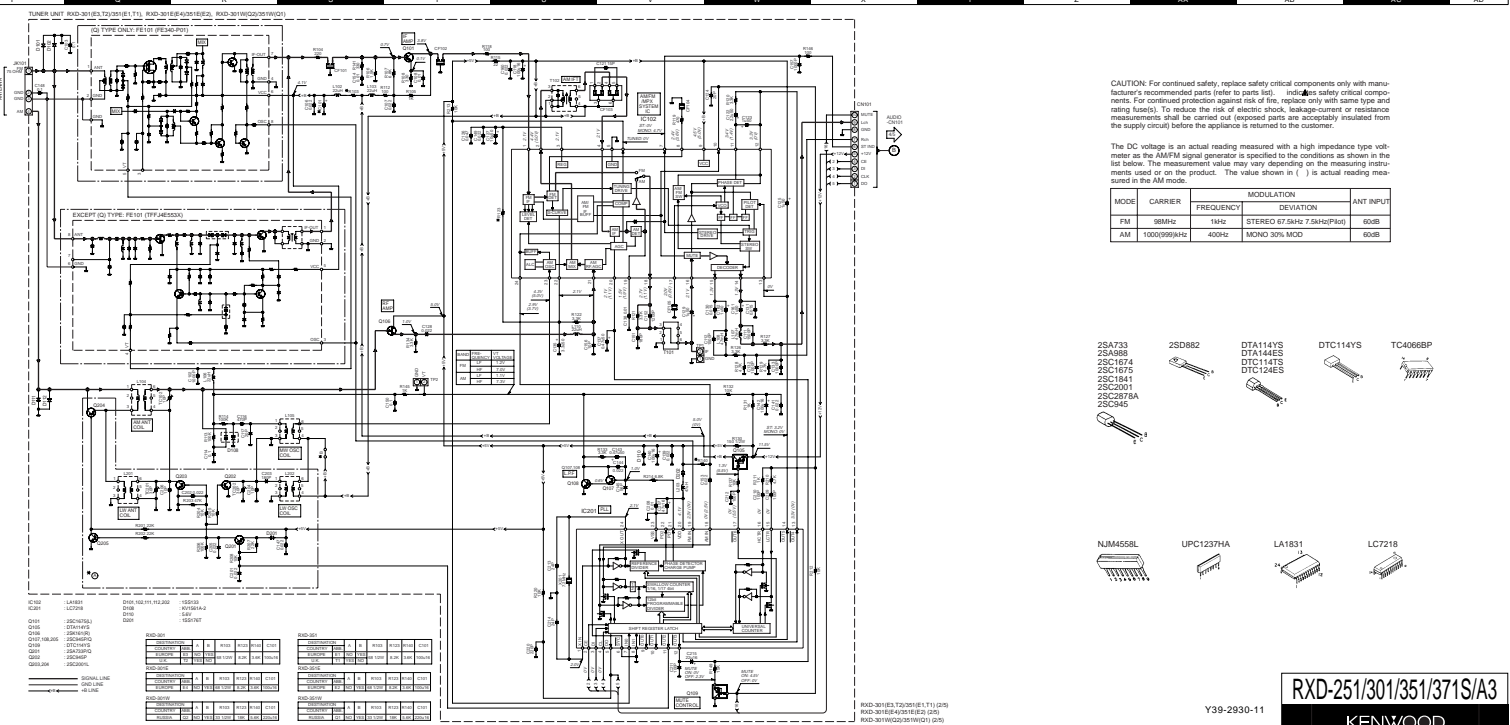

CAUTION: For continued safety, replace safety critical components only with manufacturer's recommended parts (refer to parts list).  safety critical components. For continued protection against risk of fire, replace only with same type and rating (watts). To reduce the risk of electric shock, leakage-current or resistance measurements shall be carried out (exposed parts are acceptably insulated from the supply circuit) before the appliance is returned to the customer.

The DC voltage is an actual reading measured with a high impedance type voltmeter as the AM/FM signal generator is specified to the conditions as shown in the list below. The measurement value may vary depending on the measuring instruments used or on the product. The value shown in () is actual reading measured in the AM mode.

MODE	CARRIER	MODULATION		ANT INPUT
		FREQUENCY	DEVIATION	
FM	88MHz	76Hz	STEREO 75.5kHz(Peak)	60dB
AM	1000/999kHz	400Hz	MONO 30% MOD	60dB

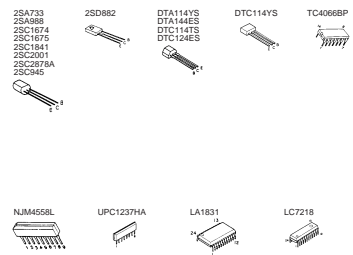

RXD-251(E) T2020(E) T11(L)P5
 RXD-301(E)R2015(E)C21P5
 RXD-351(W)C2015(W)C11P5

Y39-2930-11

RXD-251/301/351/371S/A3
KENWOOD

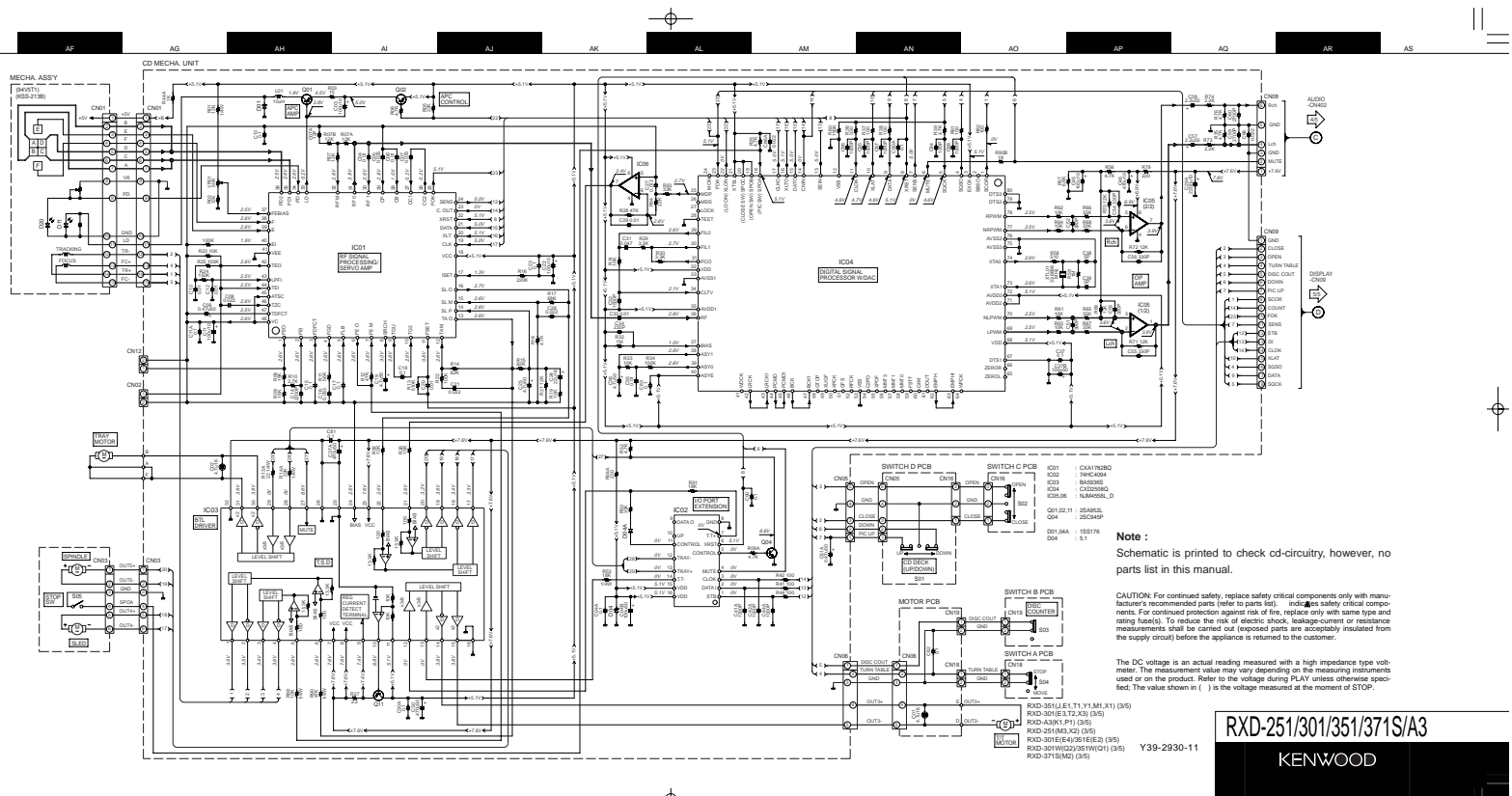

Note :
Schematic is printed to check cd-circuitry, however, no parts list in this manual.

CAUTION: For continued safety, replace safety critical components only with manufacturer's recommended parts (refer to parts list). **WARNING:** safety critical components. For continued protection against risk of fire, replace only with same type and rating (rated). To reduce the risk of electric shock, leakage-current or resistance measurements shall be carried out (exposed parts are acceptably insulated from the supply circuit) before the appliance is returned to the customer.

The DC voltage is an actual reading measured with a high impedance type voltmeter. The measurement value may vary depending on the measuring instruments used or on the product. Refer to the voltage during PLAY unless otherwise specified. The value shown in () is the voltage measured at the moment of STOP.

RXD-251/301/351/371S/A3
KENWOOD

Y39-2930-11

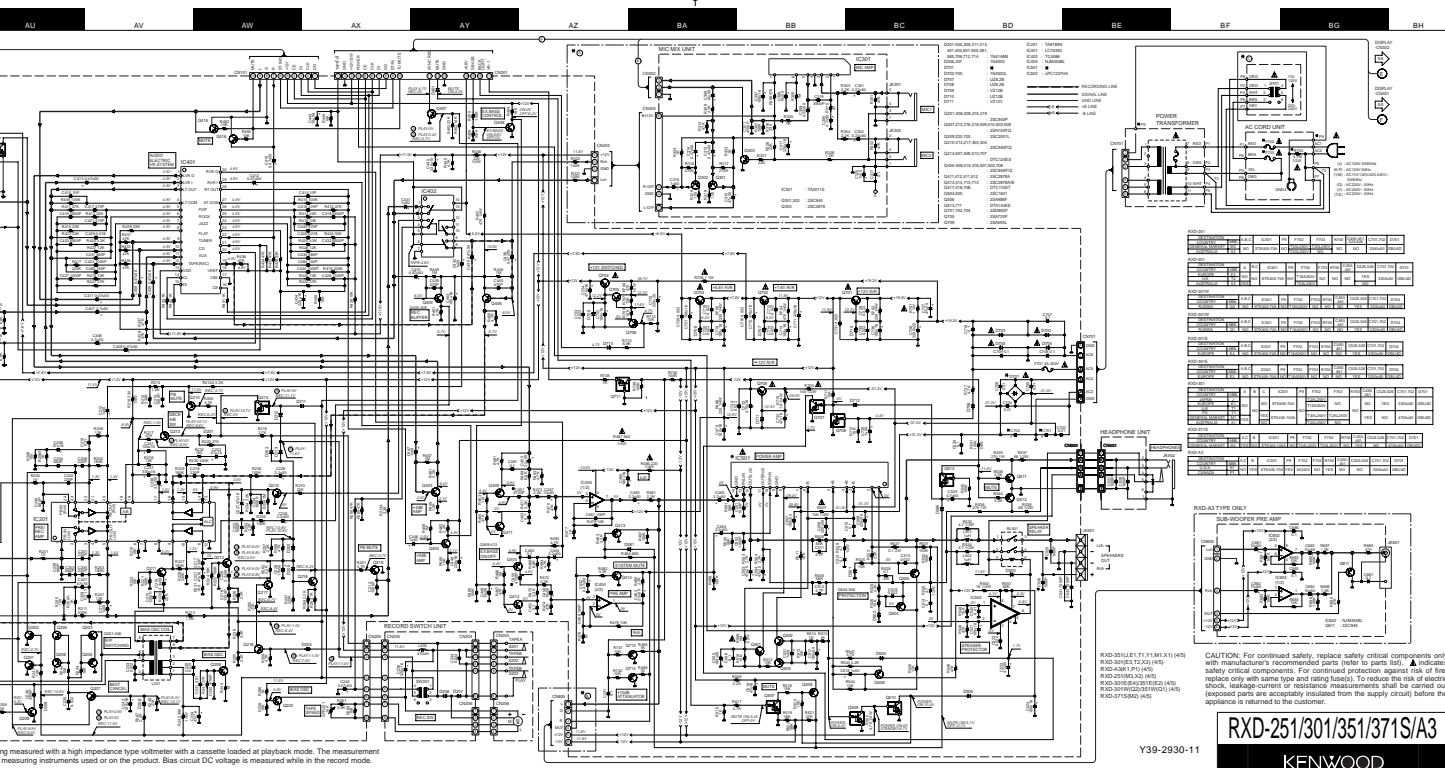

ing measured with a high impedance type voltmeter with a cassette loaded at playback mode. The measurement measuring instruments used or on the product. Bias circuit DC voltage is measured while in the record mode.

POWER TRANSFORMER

Model	Power	Primary	Secondary	Notes
RXD-251	100VA	100V	500V, 250V, 125V, 62.5V	
RXD-301	100VA	100V	500V, 250V, 125V, 62.5V	
RXD-351	100VA	100V	500V, 250V, 125V, 62.5V	
RXD-371	100VA	100V	500V, 250V, 125V, 62.5V	
RXD-371S	100VA	100V	500V, 250V, 125V, 62.5V	
RXD-A3	100VA	100V	500V, 250V, 125V, 62.5V	

RXD-A3 TYPE ONLY

Model	Power	Primary	Secondary	Notes
RXD-A3	100VA	100V	500V, 250V, 125V, 62.5V	

RXD-251/301/351/371S/A3
 RXD-301/351/371S/A3
 RXD-371S/A3
 RXD-371S/A3
 RXD-371S/A3
 RXD-371S/A3

RXD-251/301/351/371S/A3

KENWOOD

Y39-2930-11

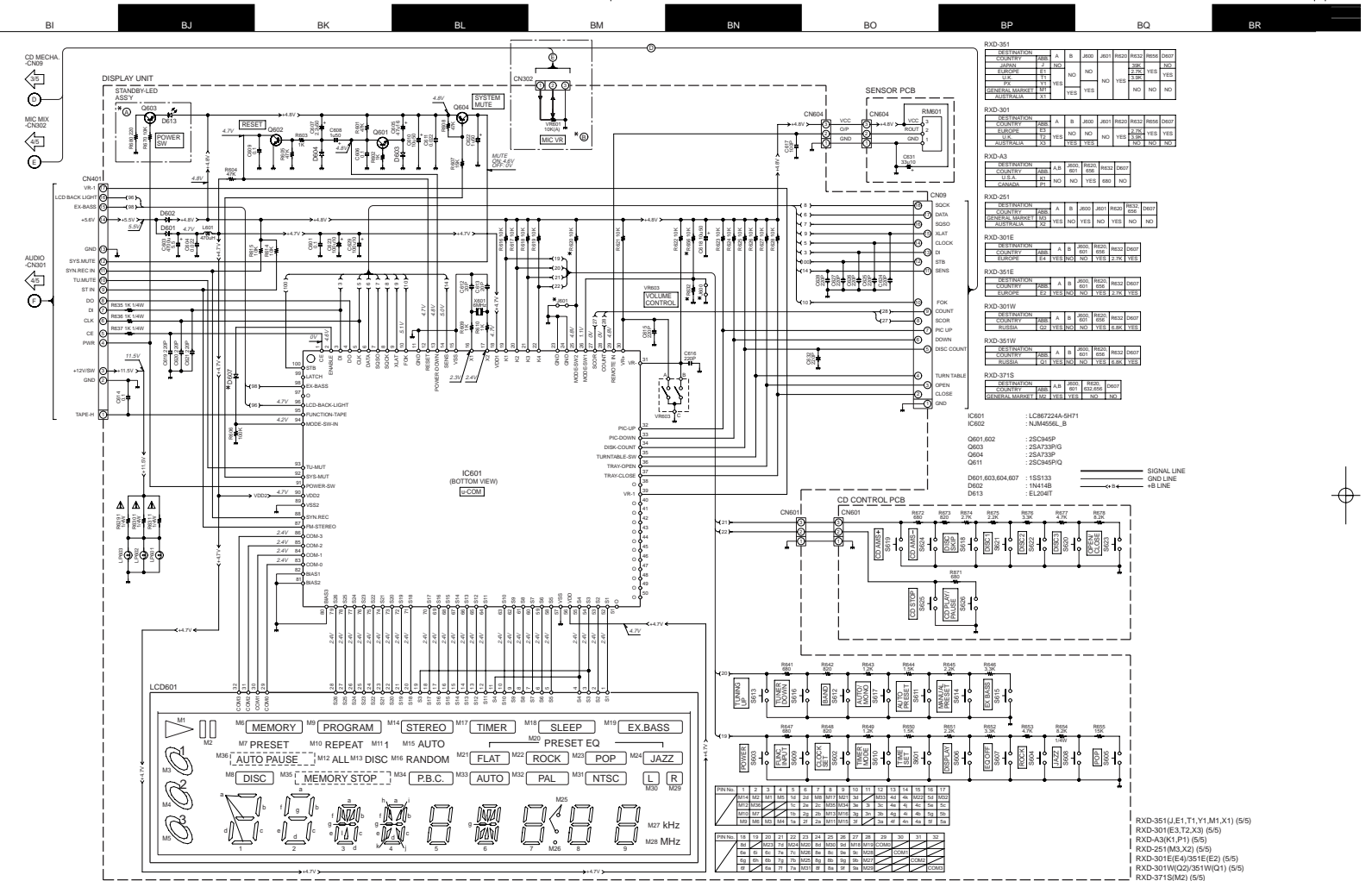

RXD-351											
DESTINATION	A	B	J60	J61	J62	J63	J64	J65	J66	J67	J68
COUNTRY	YES	NO	NO	NO	NO	NO	NO	NO	NO	NO	NO
EUROPE	YES	NO	NO	NO	NO	NO	NO	NO	NO	NO	NO
USA	NO	YES	NO	NO	NO	NO	NO	NO	NO	NO	NO
GENERAL MARKET	NO	YES	NO	NO	NO	NO	NO	NO	NO	NO	NO
AUTOMATIC	NO	NO	NO	NO	NO	NO	NO	NO	NO	NO	NO

RXD-301											
DESTINATION	A	B	J60	J61	J62	J63	J64	J65	J66	J67	J68
COUNTRY	YES	NO	NO	NO	NO	NO	NO	NO	NO	NO	NO
EUROPE	YES	NO	NO	NO	NO	NO	NO	NO	NO	NO	NO
USA	NO	YES	NO	NO	NO	NO	NO	NO	NO	NO	NO
GENERAL MARKET	NO	YES	NO	NO	NO	NO	NO	NO	NO	NO	NO
AUTOMATIC	NO	NO	NO	NO	NO	NO	NO	NO	NO	NO	NO

RXD-A3											
DESTINATION	A	B	J60	J61	J62	J63	J64	J65	J66	J67	J68
COUNTRY	YES	NO	NO	NO	NO	NO	NO	NO	NO	NO	NO
EUROPE	YES	NO	NO	NO	NO	NO	NO	NO	NO	NO	NO
USA	NO	YES	NO	NO	NO	NO	NO	NO	NO	NO	NO
GENERAL MARKET	NO	YES	NO	NO	NO	NO	NO	NO	NO	NO	NO
AUTOMATIC	NO	NO	NO	NO	NO	NO	NO	NO	NO	NO	NO

RXD-251											
DESTINATION	A	B	J60	J61	J62	J63	J64	J65	J66	J67	J68
COUNTRY	YES	NO	NO	NO	NO	NO	NO	NO	NO	NO	NO
EUROPE	YES	NO	NO	NO	NO	NO	NO	NO	NO	NO	NO
USA	NO	YES	NO	NO	NO	NO	NO	NO	NO	NO	NO
GENERAL MARKET	NO	YES	NO	NO	NO	NO	NO	NO	NO	NO	NO
AUTOMATIC	NO	NO	NO	NO	NO	NO	NO	NO	NO	NO	NO

RXD-301E											
DESTINATION	A	B	J60	J61	J62	J63	J64	J65	J66	J67	J68
COUNTRY	YES	NO	NO	NO	NO	NO	NO	NO	NO	NO	NO
EUROPE	YES	NO	NO	NO	NO	NO	NO	NO	NO	NO	NO
USA	NO	YES	NO	NO	NO	NO	NO	NO	NO	NO	NO
GENERAL MARKET	NO	YES	NO	NO	NO	NO	NO	NO	NO	NO	NO
AUTOMATIC	NO	NO	NO	NO	NO	NO	NO	NO	NO	NO	NO

RXD-351E											
DESTINATION	A	B	J60	J61	J62	J63	J64	J65	J66	J67	J68
COUNTRY	YES	NO	NO	NO	NO	NO	NO	NO	NO	NO	NO
EUROPE	YES	NO	NO	NO	NO	NO	NO	NO	NO	NO	NO
USA	NO	YES	NO	NO	NO	NO	NO	NO	NO	NO	NO
GENERAL MARKET	NO	YES	NO	NO	NO	NO	NO	NO	NO	NO	NO
AUTOMATIC	NO	NO	NO	NO	NO	NO	NO	NO	NO	NO	NO

RXD-301W											
DESTINATION	A	B	J60	J61	J62	J63	J64	J65	J66	J67	J68
COUNTRY	YES	NO	NO	NO	NO	NO	NO	NO	NO	NO	NO
EUROPE	YES	NO	NO	NO	NO	NO	NO	NO	NO	NO	NO
USA	NO	YES	NO	NO	NO	NO	NO	NO	NO	NO	NO
GENERAL MARKET	NO	YES	NO	NO	NO	NO	NO	NO	NO	NO	NO
AUTOMATIC	NO	NO	NO	NO	NO	NO	NO	NO	NO	NO	NO

RXD-351W											
DESTINATION	A	B	J60	J61	J62	J63	J64	J65	J66	J67	J68
COUNTRY	YES	NO	NO	NO	NO	NO	NO	NO	NO	NO	NO
EUROPE	YES	NO	NO	NO	NO	NO	NO	NO	NO	NO	NO
USA	NO	YES	NO	NO	NO	NO	NO	NO	NO	NO	NO
GENERAL MARKET	NO	YES	NO	NO	NO	NO	NO	NO	NO	NO	NO
AUTOMATIC	NO	NO	NO	NO	NO	NO	NO	NO	NO	NO	NO

RXD-371S											
DESTINATION	A	B	J60	J61	J62	J63	J64	J65	J66	J67	J68
COUNTRY	YES	NO	NO	NO	NO	NO	NO	NO	NO	NO	NO
EUROPE	YES	NO	NO	NO	NO	NO	NO	NO	NO	NO	NO
USA	NO	YES	NO	NO	NO	NO	NO	NO	NO	NO	NO
GENERAL MARKET	NO	YES	NO	NO	NO	NO	NO	NO	NO	NO	NO
AUTOMATIC	NO	NO	NO	NO	NO	NO	NO	NO	NO	NO	NO

CAUTION: For continued safety, replace safety critical components only with manufacturer's recommended parts (refer to parts list). ⚠ indicates safety critical components. For continued protection against risk of fire, replace only with same type and rating fuse(s). To reduce the risk of electric shock, leakage-current or resistance measurements shall be carried out (exposed parts are acceptably insulated from the supply circuit) before the appliance is returned to the customer.

The DC voltage is an actual reading measured with a high impedance type voltmeter with a cassette loaded at playback mode. The measurement value may vary depending on the measuring instruments used or on the product. Bias circuit DC voltage is measured while in the record mode.

Y39-2930-11

RXD-251/301/351/371S/A3

KENWOOD

- RXD-351(J,E1,T1,Y1,M1,X1) (5/5)
- RXD-301(E,3,T2,X3) (5/5)
- RXD-A3(K,P1) (5/5)
- RXD-251(M,3,X2) (5/5)
- RXD-301E(E,4/351E(E,2) (5/5)
- RXD-301W(C,2/351W(C,1) (5/5)
- RXD-371S(M,2) (5/5)

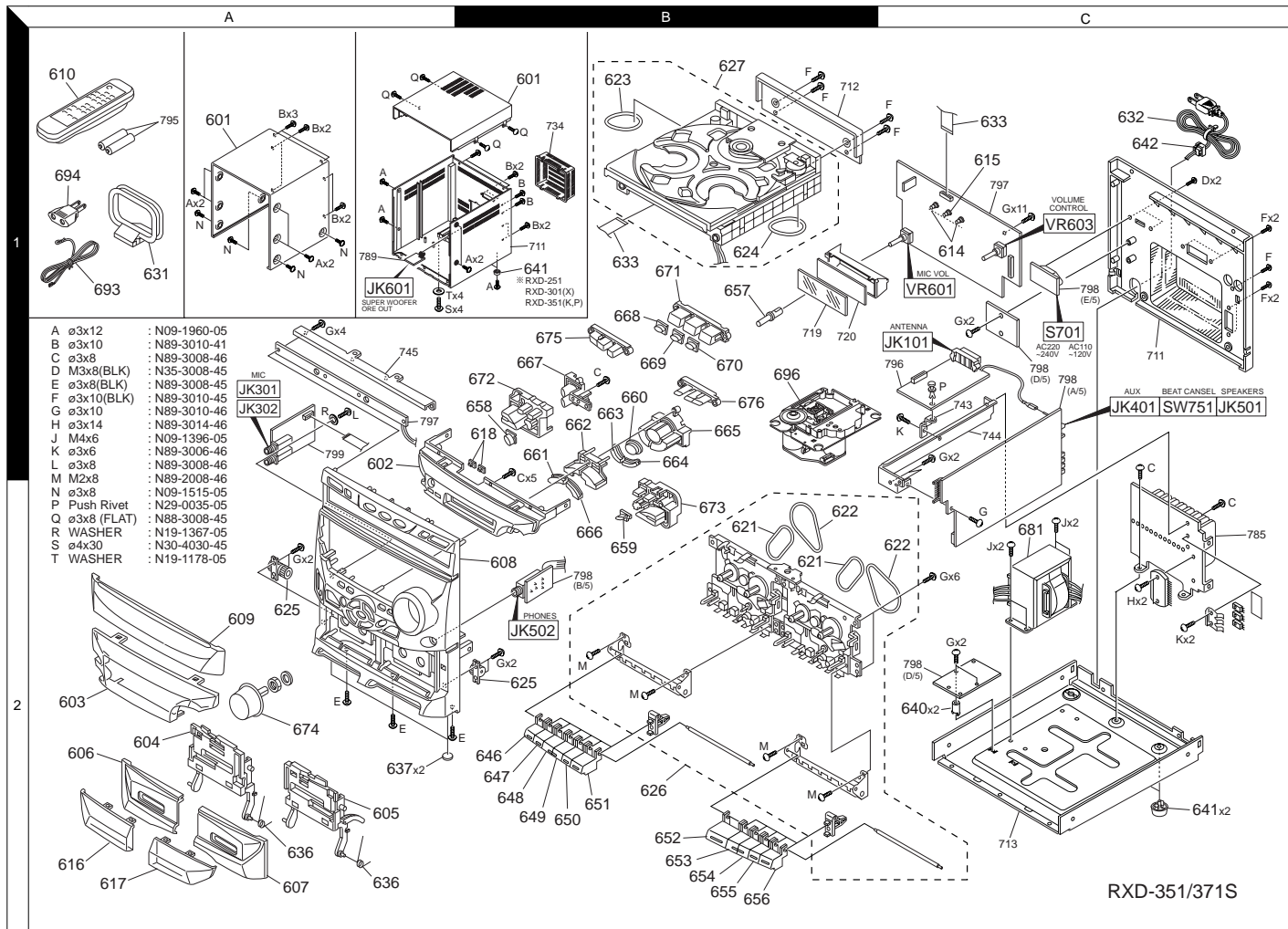

EXPLODED VIEW (UNIT)

RXD-251/301/351/371S/A3



* New Parts
 Parts without **Parts No.** are not supplied.
 Les articles non mentionnés dans le **Parts No.** ne sont pas fournis.
 Teile ohne **Parts No.** werden nicht geliefert.

Ref. No	Add-ress	New Parts	Parts No.	Description	Desti-nation	Re-marks
RXD-251/301/301E/301W/351/351E/351W/371S/A5						
601	1A	*	A01-3676-08	CABINET BLACK	X3	B
601	1A	*	A01-3677-08	CABINET GRAY	H	
601	1A	*	A01-3677-08	CABINET GRAY	H	
601	1A	*	A01-3678-08	CABINET(METAL)SILVER	E2M2	S
601	1A	*	A01-3678-08	CABINET(METAL)SILVER	M1X1Y1	S
601	1A	*	A01-3678-08	CABINET(METAL)SILVER	M1X1Y1	S
601	1A	*	A01-3679-08	CABINET(METAL)BLACK	T1E1Q1	S
601	1A	*	A01-3679-08	CABINET(METAL)BLACK	E4	B
602	1A	*	A22-1817-08	SUB PANEL	T2Q2E3	B
602	1A	*	A22-1818-08	SUB PANEL	K1P1	
602	1A	*	A22-1818-08	SUB PANEL	M1X1Y1	
602	1A	*	A22-1818-08	SUB PANEL	M2X2M3	
602	1A	*	A22-1818-08	SUB PANEL	T1E1Q1	
602	1A	*	A22-1818-08	SUB PANEL	T2E2Q2	
602	1A	*	A22-1818-08	SUB PANEL	X3E3E4	
603	2A	*	A29-1040-08	FRONT GLASS	K1P1	
603	2A	*	A29-1041-08	FRONT GLASS	E3E4	
603	2A	*	A29-1041-08	FRONT GLASS	T2Q2X3	
603	2A	*	A29-1042-08	FRONT GLASS	E2	
603	2A	*	A29-1042-08	FRONT GLASS	M1X1Y1	
603	2A	*	A29-1042-08	FRONT GLASS	T1E1Q1	
603	2A	*	A29-1043-08	FRONT GLASS	M2	
603	2A	*	A29-1044-08	FRONT GLASS	M3X2	
604	2A	*	A53-2097-08	CASSETTE HOLDER(L)		
605	2A	*	A53-2098-08	CASSETTE HOLDER(R)		
606	2A	*	A53-2099-08	CASSETTE LID(L) BLACK	E3E4	B
606	2A	*	A53-2099-08	CASSETTE LID(L) BLACK	T2Q2X3	B
606	2A	*	A53-2101-08	CASSETTE LID(L) SILVER	K1P1Y1	S
606	2A	*	A53-2101-08	CASSETTE LID(L) SILVER	M1M2M3	S
606	2A	*	A53-2101-08	CASSETTE LID(L) SILVER	Q1X1X2	S
606	2A	*	A53-2101-08	CASSETTE LID(L) SILVER	T1E1E2	S
607	2A	*	A53-2100-08	CASSETTE LID(R) BLACK	E3E4	B
607	2A	*	A53-2100-08	CASSETTE LID(R) BLACK	T2Q2X3	B
607	2A	*	A53-2102-08	CASSETTE LID(R) SILVER	K1P1Y1	S
607	2A	*	A53-2102-08	CASSETTE LID(R) SILVER	M1M2M3	S
607	2A	*	A53-2102-08	CASSETTE LID(R) SILVER	Q1X1X2	S
607	2A	*	A53-2102-08	CASSETTE LID(R) SILVER	T1E1E2	S
607	2A	*	A53-2102-08	CASSETTE LID(R) SILVER	E4	B
608	2B	*	A60-1570-08	FRONT PANEL BLACK	T2Q2E3	B
608	2B	*	A60-1571-08	FRONT PANEL BLACK	X3	B
608	2B	*	A60-1572-08	FRONT PANEL BLACK	K1P1Y1	S
608	2B	*	A60-1572-08	FRONT PANEL SILVER	T1E1E2	S
608	2B	*	A60-1572-08	FRONT PANEL SILVER	X2M3Q1	S
608	2B	*	A60-1573-08	FRONT PANEL SILVER	M1X1M2	S
609	2A	*	A60-1576-08	PANEL(CD) BLACK	E3E4	B
609	2A	*	A60-1576-08	PANEL(CD) BLACK	X2Q2X3	B
609	2A	*	A60-1577-08	PANEL(CD) SILVER	E2X2M3	S
609	2A	*	A60-1577-08	PANEL(CD) SILVER	K1P1Y1	S
609	2A	*	A60-1577-08	PANEL(CD) SILVER	M1X1M2	S
609	2A	*	A60-1577-08	PANEL(CD) SILVER	T1E1Q1	S
610	1A	*	A70-1260-08	REMOTE CONTROLLER(RC-301)	S	
614	1C	*	B09-0262-08	LAMP CAP		
615	1C	*	B09-0263-08	LED COVER		
616	2A	*	B10-3450-08	FRONT GLASS(CASSETTE)L		

L: Scandinavia K: USA P: Canada R: Mexico C: China I: Malaysia
 Y: PX(Far East, Hawaii) T: Europe E: Europe G: Germany V: China (Shanghai) B: BLACK S: SILVER H: GRAY
 Y: AAFES(Europe) X: Australia Q: Russia H: Korea M: Other Areas Δ indicates safety critical components.



* New Parts
 Parts without **Parts No.** are not supplied.
 Les articles non mentionnés dans le **Parts No.** ne sont pas fournis.
 Teile ohne **Parts No.** werden nicht geliefert.

Ref. No	Add-ress	New Parts	Parts No.	Description	Desti-nation	Re-marks
617	2A	*	B10-3451-08	FRONT GLASS(CASSETTE)R		
618	1B	*	B19-1602-08	LED LENS	E1E2E3	
618	1B	*	B19-1602-08	LED LENS	E4T1T2	
618	1B	*	B19-1602-08	LED LENS	M1M2M3	
618	1B	*	B19-1602-08	LED LENS	Q1Q2Y1	
618	1B	*	B19-1602-08	LED LENS	X1X2X3	
-	-	-	B46-0096-53	WARRANTY CARD	X1X2X3	
-	-	-	B46-0310-03	WARRANTY CARD	E1E2E3	
-	-	-	B46-0310-03	WARRANTY CARD	E4Q1Q2	
-	-	-	B46-0310-03	WARRANTY CARD	T1T2	
-	-	-	B46-0328-03	WARRANTY CARD	K1P1	
-	-	-	B46-0336-03	WARRANTY CARD	P1	
-	-	*	B60-3879-08	INSTRUCTION MANUAL(ENGLISH)	K1P1Y1	
-	-	*	B60-3879-08	INSTRUCTION MANUAL(ENGLISH)	M1X1T1	
-	-	*	B60-3879-08	INSTRUCTION MANUAL(ENGLISH)	M3X3E4	
-	-	*	B60-3879-08	INSTRUCTION MANUAL(ENGLISH)	Q1E2M2	
-	-	*	B60-3879-08	INSTRUCTION MANUAL(ENGLISH)	T2Q2X2	
-	-	*	B60-3880-08	INSTRUCTION MANUAL(FRENCH)	P1E1E3	
-	-	*	B60-3881-08	INSTRUCTION MANUAL(GERMAN)	E1E3	
-	-	*	B60-3882-08	INSTRUCTION MANUAL(DUTCH)	E1E3	
-	-	*	B60-3883-08	INSTRUCTION MANUAL(ITALIAN)	E1E3	
-	-	*	B60-3884-08	INSTRUCTION MANUAL(SPANISH)	E1M1M2	
-	-	*	B60-3884-08	INSTRUCTION MANUAL(SPANISH)	E3M3	
-	-	*	B60-3885-08	INSTRUCTION MANUAL(PH)	E2E4	
-	-	*	B60-3886-08	INSTRUCTION MANUAL(HG)	E2E4	
-	-	*	B60-3887-08	INSTRUCTION MANUAL(CZ)	E2E4	
-	-	*	B60-3888-08	INSTRUCTION MANUAL(R)	Q1Q2	
-	-	*	B60-3889-08	INSTRUCTION MANUAL(TAIWANESE)	M1M2	
621	2B	*	D16-0725-08	F BELT(CASSETTE)		
622	2B,2C	*	D16-0726-08	M BELT(CASSETTE)		
623	1B	*	D16-0727-08	LOADING BELT(CD)		
624	1B	*	D16-0728-08	LOADING GEAR BELT(CD)		
625	2A,2B	*	D39-0325-08	GEAR DAMPER		
626	2B	*	D40-1621-08	CASSETTE MECHANISM ASSY		
627	1B	*	D40-1622-08	CD MECHANISM ASSY		
Δ 631	1A	*	E03-0115-05	AC PLUG ADAPTER	M1M2M3	
Δ 632	1C	*	E30-2895-08	AC POWER CORD	K1P1	
Δ 632	1C	*	E30-2905-08	AC POWER CORD	T1T2	
Δ 632	1C	*	E30-2906-08	AC POWER CORD	M1E1Q1	
Δ 632	1C	*	E30-2906-08	AC POWER CORD	M2E2Q2	
Δ 632	1C	*	E30-2906-08	AC POWER CORD	M3E3E4	
Δ 632	1C	*	E30-2907-08	AC POWER CORD	Y1	
Δ 632	1C	*	E30-2908-08	AC POWER CORD	X1X2X3	
Δ 633	1B,1C	*	E35-2288-08	FLAT CABLE(18P)		
636	2A	*	G01-4106-08	EJECT SPRING		
637	2A	*	G11-2432-08	CUSHION(FOOT RUBBER)		
-	-	*	H10-7538-08	POLYSTYRENE FOAMED FIXTURE(L)		
-	-	*	H10-7539-08	POLYSTYRENE FOAMED FIXTURE(R)		
-	-	*	H21-0366-08	SOFT SHEET(1500X700X0.5)		
-	-	*	H25-1527-08	POLY BAG		
-	-	*	H50-2988-08	ITEM CARTON CASE	T2E3	
-	-	*	H50-2989-08	ITEM CARTON CASE	E4	
-	-	*	H50-2990-08	ITEM CARTON CASE	Q2	

L: Scandinavia K: USA P: Canada R: Mexico C: China I: Malaysia
 Y: PX(Far East, Hawaii) T: Europe E: Europe G: Germany V: China (Shanghai) B: BLACK S: SILVER H: GRAY
 Y: AAFES(Europe) X: Australia Q: Russia H: Korea M: Other Areas Δ indicates safety critical components.



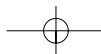

* New Parts
Parts without Parts No. are not supplied.
Les articles non mentionnés dans le Parts No. ne sont pas fournis.
Teile ohne Parts No. werden nicht geliefert.

3

Ref. No	Add-ress	New Parts	Parts No.	Description	Desti-nation	Re-marks
-		*	H50-2992-08	ITEM CARTON CASE	T1E1	
-		*	H50-2993-08	ITEM CARTON CASE	E2	
-		*	H50-2994-08	ITEM CARTON CASE	Q1	
-		*	H50-2995-08	ITEM CARTON CASE	M1	
-		*	H50-2996-08	ITEM CARTON CASE	M2	
-		*	H50-3001-08	ITEM CARTON CASE	M3	
-		*	H60-0685-08	ITEM CARTON CASE	K1P1	
-		*	H60-0686-08	ITEM CARTON CASE	X3	
-		*	H60-0687-08	ITEM CARTON CASE	X1Y1	
-		*	H60-0771-08	ITEM CARTON CASE	X2	
640	2C	*	J19-5961-08	UNIT HOLDER	E1E2E3	
640	2C	*	J19-5961-08	UNIT HOLDER	E4Q1Q2	
640	2C	*	J19-5961-08	UNIT HOLDER	T1T2	
641	2C	*	J02-1433-08	FOOT(REAR)	E1E2E3	
641	2C	*	J02-1433-08	FOOT(REAR)	M1M2E4	
641	2C	*	J02-1433-08	FOOT(REAR)	Q1Q2X1	
641	2C	*	J02-1433-08	FOOT(REAR)	T1T2Y1	
641	2C	*	J02-1434-08	FOOT(REAR)	K1P1X2	
641	2C	*	J02-1434-08	FOOT(REAR)	M3X3	
641	1C	*	J42-0330-08	POWER CORD BUSHING	E1E2E3	
Δ 642	1C	*	J42-0330-08	POWER CORD BUSHING	E4Q1Q2	
Δ 642	1C	*	J42-0330-08	POWER CORD BUSHING	M1M2Y1	
Δ 642	1C	*	J42-0330-08	POWER CORD BUSHING	T1T2X1	
646	2B	*	K29-7487-08	CASSETTE RECORD BUTTON(A)	E3E4	B
646	2B	*	K29-7487-08	CASSETTE RECORD BUTTON(A)	T2Q2X3	B
646	2B	*	K29-7498-08	CASSETTE RECORD BUTTON(A)	K1P1Y1	H
646	2B	*	K29-7498-08	CASSETTE RECORD BUTTON(A)	M1M2M3	H
646	2B	*	K29-7498-08	CASSETTE RECORD BUTTON(A)	T1E1E2	H
646	2B	*	K29-7498-08	CASSETTE RECORD BUTTON(A)	X1X2Q1	H
647	2B	*	K29-7488-08	CASSETTE PLAY BUTTON(A)	E3E4	H
647	2B	*	K29-7488-08	CASSETTE PLAY BUTTON(A)	T2Q2X3	B
647	2B	*	K29-7499-08	CASSETTE PLAY BUTTON(A)	K1P1Y1	H
647	2B	*	K29-7499-08	CASSETTE PLAY BUTTON(A)	M1M2M3	H
647	2B	*	K29-7499-08	CASSETTE PLAY BUTTON(A)	T1E1E2	H
647	2B	*	K29-7499-08	CASSETTE PLAY BUTTON(A)	X1X2Q1	H
648	2B	*	K29-7489-08	CASSETTE REWIND BUTTON(A)	E3E4	B
648	2B	*	K29-7489-08	CASSETTE REWIND BUTTON(A)	T2Q2X3	B
648	2B	*	K29-7500-08	CASSETTE REWIND BUTTON(A)	K1P1Y1	H
648	2B	*	K29-7500-08	CASSETTE REWIND BUTTON(A)	M1M2M3	H
648	2B	*	K29-7500-08	CASSETTE REWIND BUTTON(A)	T1E1E2	H
648	2B	*	K29-7500-08	CASSETTE REWIND BUTTON(A)	X1X2Q1	H
649	2B	*	K29-7490-08	CASSETTE FASTFORWARD BUTTON(A)	E3E4	B
649	2B	*	K29-7490-08	CASSETTE FASTFORWARD BUTTON(A)	T2Q2X3	B
649	2B	*	K29-7501-08	CASSETTE FASTFORWARD BUTTON(A)	K1P1Y1	H
649	2B	*	K29-7501-08	CASSETTE FASTFORWARD BUTTON(A)	M1M2M3	H
649	2B	*	K29-7501-08	CASSETTE FASTFORWARD BUTTON(A)	T1E1E2	H
649	2B	*	K29-7501-08	CASSETTE FASTFORWARD BUTTON(A)	X1X2Q1	H
650	2B	*	K29-7491-08	CASSETTE STOP/EJECT BUTTON(A)	E3E4	B
650	2B	*	K29-7491-08	CASSETTE STOP/EJECT BUTTON(A)	T2Q2X3	B
650	2B	*	K29-7502-08	CASSETTE STOP/EJECT BUTTON(A)	K1P1Y1	H
650	2B	*	K29-7502-08	CASSETTE STOP/EJECT BUTTON(A)	M1M2M3	H
650	2B	*	K29-7502-08	CASSETTE STOP/EJECT BUTTON(A)	T1E1E2	H
650	2B	*	K29-7502-08	CASSETTE STOP/EJECT BUTTON(A)	X1X2Q1	H
651	2B	*	K29-7492-08	CASSETTE PAUSE BUTTON(A)	E3E4	B

L : Scandinavia K : USA P : Canada R : Mexico C : China I : Malaysia
Y : PX(Far East, Hawaii) T : Europe E : Europe G : Germany V : China (Shanghai) B : BLACK S : SILVER H : GRAY
X : Australia Q : Russia H : Korea M : Other Areas Δ indicates safety critical components.

* New Parts
Parts without Parts No. are not supplied.
Les articles non mentionnés dans le Parts No. ne sont pas fournis.
Teile ohne Parts No. werden nicht geliefert.

4

Ref. No	Add-ress	New Parts	Parts No.	Description	Desti-nation	Re-marks
651	2B	*	K29-7492-08	CASSETTE PAUSE BUTTON(A)	T2Q2X3	B
651	2B	*	K29-7503-08	CASSETTE PAUSE BUTTON(A)	K1P1Y1	H
651	2B	*	K29-7503-08	CASSETTE PAUSE BUTTON(A)	M1M2M3	H
651	2B	*	K29-7503-08	CASSETTE PAUSE BUTTON(A)	T1E1E2	H
651	2B	*	K29-7503-08	CASSETTE PAUSE BUTTON(A)	X1X2Q1	H
652	2B	*	K29-7493-08	CASSETTE PLAY BUTTON(B)	E3E4	B
652	2B	*	K29-7493-08	CASSETTE PLAY BUTTON(B)	T2Q2X3	B
652	2B	*	K29-7504-08	CASSETTE PLAY BUTTON(B)	K1P1Y1	H
652	2B	*	K29-7504-08	CASSETTE PLAY BUTTON(B)	M1M2M3	H
652	2B	*	K29-7504-08	CASSETTE PLAY BUTTON(B)	T1E1E2	H
652	2B	*	K29-7504-08	CASSETTE PLAY BUTTON(B)	X1X2Q1	H
652	2B	*	K29-7504-08	CASSETTE PLAY BUTTON(B)	E3E4	B
653	2B	*	K29-7494-08	CASSETTE REWIND BUTTON(B)	E3E4	B
653	2B	*	K29-7494-08	CASSETTE REWIND BUTTON(B)	T2Q2X3	B
653	2B	*	K29-7505-08	CASSETTE REWIND BUTTON(B)	K1P1Y1	H
653	2B	*	K29-7505-08	CASSETTE REWIND BUTTON(B)	M1M2M3	H
653	2B	*	K29-7505-08	CASSETTE REWIND BUTTON(B)	T1E1E2	H
653	2B	*	K29-7505-08	CASSETTE REWIND BUTTON(B)	X1X2Q1	H
653	2B	*	K29-7505-08	CASSETTE REWIND BUTTON(B)	E3E4	B
653	2B	*	K29-7495-08	CASSETTE FASTFORWARD BUTTON(B)	E3E4	B
653	2B	*	K29-7495-08	CASSETTE FASTFORWARD BUTTON(B)	T2Q2X3	B
653	2B	*	K29-7495-08	CASSETTE FASTFORWARD BUTTON(B)	K1P1Y1	H
653	2B	*	K29-7495-08	CASSETTE FASTFORWARD BUTTON(B)	M1M2M3	H
653	2B	*	K29-7495-08	CASSETTE FASTFORWARD BUTTON(B)	T1E1E2	H
653	2B	*	K29-7495-08	CASSETTE FASTFORWARD BUTTON(B)	X1X2Q1	H
654	2B	*	K29-7506-08	CASSETTE FASTFORWARD BUTTON(B)	E3E4	B
654	2B	*	K29-7506-08	CASSETTE FASTFORWARD BUTTON(B)	T2Q2X3	B
654	2B	*	K29-7506-08	CASSETTE FASTFORWARD BUTTON(B)	K1P1Y1	H
654	2B	*	K29-7506-08	CASSETTE FASTFORWARD BUTTON(B)	M1M2M3	H
654	2B	*	K29-7496-08	CASSETTE STOP/EJECT BUTTON(B)	E3E4	B
654	2B	*	K29-7496-08	CASSETTE STOP/EJECT BUTTON(B)	T2Q2X3	B
655	2B	*	K29-7507-08	CASSETTE STOP/EJECT BUTTON(B)	K1P1Y1	H
655	2B	*	K29-7507-08	CASSETTE STOP/EJECT BUTTON(B)	M1M2M3	H
655	2B	*	K29-7507-08	CASSETTE STOP/EJECT BUTTON(B)	T1E1E2	H
655	2B	*	K29-7507-08	CASSETTE STOP/EJECT BUTTON(B)	X1X2Q1	H
655	2B	*	K29-7507-08	CASSETTE STOP/EJECT BUTTON(B)	E3E4	B
656	2B	*	K29-7497-08	CASSETTE PAUSE BUTTON(B)	T2Q2X3	B
656	2B	*	K29-7497-08	CASSETTE PAUSE BUTTON(B)	K1P1Y1	H
656	2B	*	K29-7508-08	CASSETTE PAUSE BUTTON(B)	M1M2M3	H
656	2B	*	K29-7508-08	CASSETTE PAUSE BUTTON(B)	T1E1E2	H
656	2B	*	K29-7508-08	CASSETTE PAUSE BUTTON(B)	X1X2Q1	H
657	1B	*	K29-7509-08	KNOB(MIC)	M1X1M2	H
657	1B	*	K29-7509-08	KNOB(MIC)	X3	H
658	1B	*	K29-7511-08	KNOB(DISPLAY/DEMO)		
659	2B	*	K29-7519-08	KNOB(BAND)		
660	1B	*	K29-7512-08	KNOB(EX.BASS)		
661	1A	*	K29-7513-08	KNOB(ROCK)		
662	1A	*	K29-7514-08	KNOB(BASE ROCK)		
663	1A	*	K29-7515-08	KNOB(POP)		
664	1A	*	K29-7516-08	KNOB(JAZZ)		
665	1A	*	K29-7517-08	KNOB(BASE JAZZ)		
666	2B	*	K29-7518-08	KNOB(FLAT)		
667	1B	*	K29-7520-08	KNOB(ON/STANDBY.INPUT)	E3E4	B
667	1B	*	K29-7520-08	KNOB(ON/STANDBY.INPUT)	T2Q2X3	B
667	1B	*	K29-7549-08	KNOB(ON/STANDBY.INPUT)	E1E2T1	H
667	1B	*	K29-7549-08	KNOB(ON/STANDBY.INPUT)	M1M2M3	H
667	1B	*	K29-7549-08	KNOB(ON/STANDBY.INPUT)	Y1	H
667	1B	*	K29-7549-08	KNOB(ON/STANDBY.INPUT)	X1X2Q1	H
667	1B	*	K29-7549-08	KNOB(ON/STANDBY.INPUT)	K1P1	H
667	1B	*	K29-7550-08	KNOB(POWER INPUT)		
668	1B	*	K29-7521-08	KNOB(DISC 1)		
669	1B	*	K29-7522-08	KNOB(DISC 2)		

L : Scandinavia K : USA P : Canada R : Mexico C : China I : Malaysia
Y : PX(Far East, Hawaii) T : Europe E : Europe G : Germany V : China (Shanghai) B : BLACK S : SILVER H : GRAY
X : Australia Q : Russia H : Korea M : Other Areas Δ indicates safety critical components.

PARTS LIST

RXD-251/301/351/371S/A3

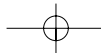

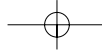

* New Parts
 Parts without **Parts No.** are not supplied.
 Les articles non mentionnés dans le **Parts No.** ne sont pas fournis.
 Teile ohne **Parts No.** werden nicht geliefert. 7

Ref. No	Add- ress	New Parts	Parts No.	Description	Desti- nation	Re- marks
C151,152			C91-0759-05	CERAMIC 1500PF M		
C153			C91-0085-05	CERAMIC 0.022UF N		
C155			C91-0745-05	CERAMIC 100PF K		
C157			C91-0757-05	CERAMIC 1000PF K		
C160			C91-0085-05	CERAMIC 0.022UF N		
C161,162			CE04KW1H010M	ELECTRO 1.0UF 50WV		
C164			CK45FB1H103Z	CERAMIC 0.010UF Z	M2	
C164			CQ93FMG1H682J	MYLAR 6800PF J	M1M2M3	
C164			CQ93FMG1H682J	MYLAR 6800PF J	Y1	
C165			CK45FB1H223Z	CERAMIC 0.022UF Z	M2	
C165			CQ93FMG1H682J	MYLAR 6800PF J	K1P1Y1	
C165			CQ93FMG1H682J	MYLAR 6800PF J	M1X1X2	
C165			CQ93FMG1H682J	MYLAR 6800PF J	M3X3	
C166			CK45FB1H223Z	CERAMIC 0.022UF Z	M2	
C167			CQ93FMG1H471J	MYLAR 470PF J	M2	
C169			C91-0085-05	CERAMIC 0.022UF N	M2	
C170			C91-0769-05	CERAMIC 0.010UF K		
C171			CK45FB1H104Z	CERAMIC 0.10UF Z	K1P1Y1	
C171			CK45FB1H104Z	CERAMIC 0.10UF Z	M1X1X2	
C171			CK45FB1H104Z	CERAMIC 0.10UF Z	M3X3	
C171			CK45FB1H223Z	CERAMIC 0.022UF Z	M2	
C174,175			CQ92FM1H682J	MYLAR 6800PF J	M2	
C201			CK45FB1H561K	CERAMIC 560PF K	M2	
C202			CQ09S1H472J	POLYSTY 4700PF J	M2	
C204			C91-0085-05	CERAMIC 0.022UF N	M2	
C205			CE04KW1C470M	ELECTRO 47UF 16WV	M2	
C207			CE04KW1C470M	ELECTRO 47UF 16WV		
C208			C91-0769-05	CERAMIC 0.010UF K		
C209			C91-0745-05	CERAMIC 100PF K		
C210-212			C91-0745-05	CERAMIC 100PF K		
C212			C91-0085-05	CERAMIC 0.022UF N	M2	
C213,214			CC45FCH1H240J	CERAMIC 24PF J	K1P1Y1	
C213,214			CC45FCH1H240J	CERAMIC 24PF J	M1X1X2	
C213,214			CC45FCH1H240J	CERAMIC 24PF J	M3X3	
C213,214			CC45FCH1H270J	CERAMIC 27PF J	M2	
C215			CE04KW1C220M	ELECTRO 22UF 16WV		
C216			C91-0085-05	CERAMIC 0.022UF N	M2	
C217			C91-0085-05	CERAMIC 0.022UF N	M2	
C220			C91-0749-05	CERAMIC 220PF K		
C221-223			C91-0749-05	CERAMIC 220PF K	K1P1Y1	
C221-223			C91-0749-05	CERAMIC 220PF K	M1X1X2	
C221-223			C91-0749-05	CERAMIC 220PF K	M3X3	
TC101,102		*	C05-0238-08	TRIMMER CON 10PS TZ-03N100TR		
TC201		*	C05-0238-08	TRIMMER CON 10PS TZ-03N100TR	M2	
CN101		*	E40-8336-08	PIN ASSY (10P)		
JK101			E70-0070-08	ANTENNA TERMINAL (4P)		
CF101			L72-0591-08	CERAMIC F SFE10.7MA5 RED		
CF102			L72-0586-08	CERAMIC F SFE10.7MSG3GYM RED		
CF103			L72-0587-08	CERAMIC F SFZ450B		
CF104			L78-0651-08	RESONATOR CDA10.7MG43-A		
CF105			L78-0641-08	RESONATOR CSB456F15		
L101			L31-0622-08	FM ANT COIL PC-8474-1		
L102			L31-0623-08	FM RF COIL PC-8867		
L103			L32-0584-08	FM OSC COIL R22-F036X ORG		

L : Scandinavia K : USA P : Canada R : Mexico C : China I : Malaysia
 Y : PX(Far East, Hawaii) T : Europe E : Europe G : Germany V : China (Shanghai) B : BLACK S : SILVER H : GRAY
 Y : AAFES(Europe) X : Australia Q : Russia H : Korea M : Other Areas Δ indicates safety critical components.

* New Parts
 Parts without **Parts No.** are not supplied.
 Les articles non mentionnés dans le **Parts No.** ne sont pas fournis.
 Teile ohne **Parts No.** werden nicht geliefert. 8

Ref. No	Add- ress	New Parts	Parts No.	Description	Desti- nation	Re- marks
L104			L31-0618-08	AM ANT COIL TWS-358-762		
L105			L32-0581-08	MW OSC COIL TWS-358-751		
L106			L39-1340-08	INDUCTANCE 473K	M2	
L107,108			L39-1340-08	INDUCTANCE 473K		
L201		*	L31-0634-08	SW ANT COIL	M2	
L202		*	L32-1005-08	SW OSC COIL	M2	
L203			L39-1344-08	P. COIL 470K-T		
L204			L39-1340-08	INDUCTANCE 473K	M2	
L205			L39-1344-08	P. COIL 470K-T	M2	
T101			L30-0926-08	FM IFT TWS-358-412		
T102			L30-0922-08	AM IFT R22-E792		
X201		*	L77-2243-08	X' TAL(7.2MHZ)		
R130		*	RS14GB2H101J	FL-PROOF RS 100 J 1/2W	M2	
R130		*	RD14GB2H151J	RD 150 J 1/2W	K1P1Y1	
R130		*	RD14GB2H151J	RD 150 J 1/2W	M1X1X2	
R130		*	RD14GB2H151J	RD 150 J 1/2W	M3X3	
D101,102			1S133T	DIODE		
D105			1S133T	DIODE		
D106		*	KV1340A-2	DIODE		
D108		*	KV1561A-2	DIODE		
D110			MTZ5.6B	ZENER DIODE	K1P1Y1	
D110			MTZ5.6B	ZENER DIODE	M1X1X2	
D110			MTZ6.2B	ZENER DIODE	M3X3	
D111,112			1S133T	DIODE	M2	
D111,112			1S133T	DIODE	M1X1X2	
D111,112			1S133T	DIODE	M2	
D202			1S133T	DIODE	M3X3	
IC101			LA1186N	IC		
IC102			LA1831	IC(AM/FM TUNER)		
IC201			LC7218	IC(PLL FREQUENCY SYNTHESIZER)		
Q100			2SC2001L	TRANSISTOR	M2	
Q101			2SC1675(L)	TRANSISTOR		
Q102			2SC1674(L)	TRANSISTOR		
Q105		*	DTA114YS	TRANSISTOR		
Q106		*	2SK544F-T	FET		
Q107,108			2SC945	TRANSISTOR		
Q109			DTC114YS	TRANSISTOR		
Q110-111			DTC114YS	TRANSISTOR	M1Y1M3	
Q110-111			2SC2878A	TRANSISTOR	M2	
Q112			2SC2878A	TRANSISTOR	M2	
Q113			DTA144ES	TRANSISTOR	M2	
Q114			2SC2001L	TRANSISTOR	M2	
Q115,116			DTC114YS	TRANSISTOR	M2	
Q201			DTA144ES	TRANSISTOR	M2	
Q202,203			2SC2878A	TRANSISTOR	M2	
TUNER UNIT (E1T1Q1E2T2Q2E3E4)						
FE101		*	W02-2681-08	FM FRONT END	E1E2E3	
FE101		*	W02-2681-08	FM FRONT END	E4T1T2	
FE101		*	W02-2682-08	FM FRONT END	Q1Q2	
C101			CE04KW1C101M	ELECTRO 100UF 16WV		
C102			CK45FB1H102K	CERAMIC 1000PF K		
C103			CK45FB1H104K	CERAMIC 0.10UF K		
C106,107			CK45FB1E223Z	CERAMIC 0.022UF Z		

L : Scandinavia K : USA P : Canada R : Mexico C : China I : Malaysia
 Y : PX(Far East, Hawaii) T : Europe E : Europe G : Germany V : China (Shanghai) B : BLACK S : SILVER H : GRAY
 Y : AAFES(Europe) X : Australia Q : Russia H : Korea M : Other Areas Δ indicates safety critical components.

PARTS LIST

RXD-251/301/351/371S/A3

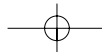

* New Parts
 Parts without **Parts No.** are not supplied.
 Les articles non mentionnés dans le **Parts No.** ne sont pas fournis.
 Teile ohne **Parts No.** werden nicht geliefert.

9

Ref. No	Add-ress	New Parts	Parts No.	Description	Desti-nation	Re-marks
C108			CK45FB1C103K	CERAMIC 0.010UF K		
C111,112			CK45FB1C152K	CERAMIC 1500PF K		
C114			CK45FB1H104Z	CERAMIC 0.10UF Z		
C116			CQ93FMG1H471J	MYLAR 470PF J		
C117			CC45FSL1H200J	CERAMIC 20PF J		
C118			CE04KW1C101M	ELECTRO 100UF 16WV		
C121			CC45FSL1H150J	CERAMIC 15PF J		
C122			CE04KW1H2R2M	ELECTRO 2.2UF 50WV		
C123			CE04KW1H010M	ELECTRO 1.0UF 50WV		
C124			CC45FSL1H200J	CERAMIC 20PF J		
C125			CE04KW1H010M	ELECTRO 1.0UF 50WV		
C126			CK45FB1H473Z	CERAMIC 0.047UF Z		
C127			CE04KW1H100M	ELECTRO 10UF 50WV		
C128			CK45FB1E223Z	CERAMIC 0.022UF Z		
C129			CE04KW1H010M	ELECTRO 1.0UF 50WV		
C130,131			CQ92FM1H153J	MYLAR 0.015UF J		
C132,133			CQ92FM1H102J	MYLAR 1000PF J		
C135			CE04KW1H3R3M	ELECTRO 3.3UF 50WV		
C137			CE04KW1HR47M	ELECTRO 0.47UF 50WV		
C138			CK45FB1C103K	CERAMIC 0.010UF K		
C139			CK45FB1E223Z	CERAMIC 0.022UF Z		
C140			CE04KW1C101M	ELECTRO 100UF 16WV		
C141			CK45FB1E223Z	CERAMIC 0.022UF Z		
C142			CE04KW1C101M	ELECTRO 100UF 16WV		
C143			CE04KW1HR47M	ELECTRO 0.47UF 50WV		
C144			CK45FB1E223Z	CERAMIC 0.022UF Z		
C145			CC45FSL1H560J	CERAMIC 56PF J		
C147			CK45FB1E223Z	CERAMIC 0.022UF Z		
C148			CK45FB1H104Z	CERAMIC 0.10UF Z		
C149			CK45FB1E223Z	CERAMIC 0.022UF Z		
C150			CK45FB1H104Z	CERAMIC 0.10UF Z		
C151			CK45FB1H181K	CERAMIC 180PF K		
C152			CK45FB1E122K	CERAMIC 1200PF K		
C153			CK45FB1E223Z	CERAMIC 0.022UF Z		
C154			CK45FB1C103K	CERAMIC 0.010UF K		
C156			CC45FCH1H100J	CERAMIC 10PF J		
C157			CK45FB1H102K	CERAMIC 1000PF K		
C160			CK45FB1E223Z	CERAMIC 0.022UF Z		
C161,162			CE04KW1H010M	ELECTRO 1.0UF 50WV		
C201,202			CK45FB1E223Z	CERAMIC 0.022UF Z	T1T2	
C203			CQ93FMG1H181J	MYLAR 180PF J	T1T2	
C204			CC45FCH1H100J	CERAMIC 10PF J	T1T2	
C205			CK45FB1E223Z	CERAMIC 0.022UF Z	T1T2	
C206			CC45FCH1H100J	CERAMIC 10PF J	T1T2	
C207			CE04KW1C470M	ELECTRO 47UF 16WV		
C208			CK45FB1C103K	CERAMIC 0.010UF K		
C209-212			CK45FB1H101K	CERAMIC 100PF K		
C213,214			CC45FSL1H240J	ELECTRO 24PF J		
C215			CE04KW1C220M	ELECTRO 22UF 16WV		
C220			CK45FB1H221K	CERAMIC 220PF K		
TC102		*	C05-0238-08	TRIMMER 10P		
TC201,202		*	C05-0239-08	TRIMMER 30P	T1T2	
CN101		*	E40-8336-08	PIN ASSY(10P)		
JK101		*	E20-0321-05	ANTENNA TERMINAL(3P)		

L: Scandinavia K: USA P: Canada R: Mexico C: China I: Malaysia
 Y: PX(Far East, Hawaii) T: Europe E: Europe G: Germany V: China (Shanghai) B: BLACK S: SILVER H: GRAY
 Y: AAFES(Europe) X: Australia Q: Russia H: Korea M: Other Areas Δ indicates safety critical components.



* New Parts
 Parts without **Parts No.** are not supplied.
 Les articles non mentionnés dans le **Parts No.** ne sont pas fournis.
 Teile ohne **Parts No.** werden nicht geliefert.

10

Ref. No	Add-ress	New Parts	Parts No.	Description	Desti-nation	Re-marks
TP1,2			E40-8111-08	40P PIN HEADER		
CF103			L72-0587-08	CERAMIC F		
CF104			L78-0651-08	RESONATOR		
CF105			L78-0641-08	RESONATOR		
L102,103			L39-1334-08	COIL		
L104			L31-0618-08	AM ANT COIL		
L105			L32-0581-08	MW OSC COIL		
L106			L39-1334-08	COIL		
L107,108			L39-1340-08	INDUCTANCE		
L110			L39-1332-08	COIL		
L201		*	L31-0635-08	ANT COIL	T1T2	
L202			L32-0581-08	COIL(CHOKE) 470UH	E1E2E3	
L202			L32-0581-08	COIL(CHOKE) 470UH	E4Q1Q2	
L203		*	L32-1008-08	OSC COIL	T1T2	
SF101,102		*	L39-1344-08	COIL		
T101			L72-0615-08	C.FILTER		
T102			L79-1229-08	FTZ L.P.F		
X201		*	L30-0922-08	AM IFT		
R103		*	L77-2243-08	CRYSTAL		
R103		*	RD14GB2H330J	RD 33 J 1/2W	Q1Q2	
R103		*	RD14GB2H680J	RD 68 J 1/2W	E1E2E3	
R103		*	RD14GB2H680J	RD 68 J 1/2W	E4T1T2	
R130		*	RD14GB2H151J	RD 150 J 1/2W		
D101,102			1S5133T-77	DIODE		
D108		*	KV1561A-2	DIODE		
D110			MT25.6B	ZENER DIODE		
D111,112			1S5133T-77	DIODE		
D201			1S5133T-77	DIODE	T1T2	
D202			1S5133T-77	DIODE		
IC102			LA1831A-KEN	IC(AM/FM/MPX SYSTEM IC)		
IC201			LC7218	IC(PLL FREQUENCY SYNTHESIZER)		
Q101			2SC1675(L)	TRANSISTOR		
Q105			DTA114YS	TRANSISTOR		
Q106		*	2SK544F-T	TRANSISTOR		
Q107,108			2SC945	TRANSISTOR		
Q109			DTC114YS	TRANSISTOR		
Q201			2SA733	TRANSISTOR	T1T2	
Q202			2SC945	TRANSISTOR	T1T2	
Q203,204			2SC2001(L)	TRANSISTOR	T1T2	
Q205			2SC945	TRANSISTOR	T1T2	
AUDIO UNIT						
C201,202			CK45FB1H221K	CERAMIC 220PF K		
C203,204			CK45FB1H681K	CERAMIC 680PF K		
C205,206			CK45FB1H221K	CERAMIC 220PF K		
C207,208			CE04KW1C470M	ELECTRO 47UF 16WV		
C209,210			CQ92FM1H103J	MYLAR 0.010UF J		
C211,212			CE04KW1H1R0M	ELECTRO 1.0UF 50WV		
C213,214			CK45FB1C152K	CERAMIC 1500PF K		
C215,216			C91-0758-05	CERAMIC 1200PF M		
C217,218			CK45FB1H221K	CERAMIC 220PF K		
C219,220			CE04KW1H3R3M	ELECTRO 3.3UF 50WV		
C221,222			CE04KW1C470M	ELECTRO 47UF 16WV		
C223,224			CK45FB1H102K	CERAMIC 1000PF K		

L: Scandinavia K: USA P: Canada R: Mexico C: China I: Malaysia
 Y: PX(Far East, Hawaii) T: Europe E: Europe G: Germany V: China (Shanghai) B: BLACK S: SILVER H: GRAY
 Y: AAFES(Europe) X: Australia Q: Russia H: Korea M: Other Areas Δ indicates safety critical components.



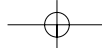

* New Parts
Parts without **Parts No.** are not supplied.
Les articles non mentionnés dans le **Parts No.** ne sont pas fournis.
Teile ohne **Parts No.** werden nicht geliefert.

15

Ref. No	Add-ress	New Parts	Parts No.	Description	Desti-nation	Re-marks
Δ D701		*	GBU4D	DIODE	E4T1T2	
Δ D701		*	GBU4D	DIODE	K1P1M3	
Δ D701		*	GBU4D	DIODE	Q1Q2X2	
Δ D701		*	GBU4D	DIODE	X3	
Δ D701		*	GBU6D	DIODE	M1M2X1	
Δ D701		*	GBU6D	DIODE	Y1	
Δ D702-705			1N4002L	DIODE		
Δ D706			1SS133T-77	DIODE		
Δ D707			MTZ8.2B	ZENER DIODE		
Δ D708			MTZ6.2B	ZENER DIODE		
Δ D709-711			MTZ12B	ZENER DIODE		
Δ D712			1SS133T-77	DIODE		
Δ D714			1SS133T-77	DIODE		
Δ IC201			TA8189N	IC		
Δ IC301			TA2011S	IC		
Δ IC301		*	TA2011S	IC	M1X1M2	
Δ IC401		*	LC7539Z	IC	X3	
Δ IC402			TC4066BP	IC(ANALOG/ DIGITAL SW)		
Δ IC404			NJM4558L	IC(OP AMP X2)		
Δ IC501		*	STK-405-100A	IC	M1M2X1	
Δ IC501		*	STK-405-100A	IC	Y1	
Δ IC501		*	STK-405-70A	IC	E1E2E3	
Δ IC501		*	STK-405-70A	IC	E4T1T2	
Δ IC501		*	STK-405-70A	IC	K1P1M3	
Δ IC501		*	STK-405-70A	IC	Q1Q2X2	
Δ IC501		*	STK-405-70A	IC	X3	
Δ IC502			UPC1237HA	IC(POWER AMP)		
Δ IC602			NJM4558L	IC(OP AMP X2)		
Δ Q201-206			2SC945	TRANSISTOR		
Δ Q207			2SA733	TRANSISTOR	K1P1	
Δ Q208			2SC945	TRANSISTOR		
Δ Q209			2SC2001L	TRANSISTOR		
Δ Q210-212			2SC945	TRANSISTOR		
Δ Q213			2SA733	TRANSISTOR		
Δ Q214			DTC124ES	TRANSISTOR		
Δ Q215			2SC945	TRANSISTOR		
Δ Q216			2SA733	TRANSISTOR		
Δ Q217			2SC945	TRANSISTOR		
Δ Q218			2SA733	TRANSISTOR		
Δ Q219			2SC945	TRANSISTOR		
Δ Q220			2SC2001L	TRANSISTOR		
Δ Q301.302			2SC945	TRANSISTOR		
Δ Q403-408			2SC945	TRANSISTOR		
Δ Q409.410			2SA733	TRANSISTOR		
Δ Q411-414			2SC2878A	TRANSISTOR		
Δ Q415.416			2SC945	TRANSISTOR		
Δ Q417.418			DTC114TS	TRANSISTOR		
Δ Q501.502			2SC945	TRANSISTOR		
Δ Q503			2SA733	TRANSISTOR		
Δ Q504.505			2SC1841	TRANSISTOR		
Δ Q506			2SA988	TRANSISTOR		
Δ Q507			DTC124ES	TRANSISTOR		
Δ Q508			2SA733	TRANSISTOR		
Δ Q509.510			DTC124ES	TRANSISTOR		
Δ Q511.512			2SC2878A	TRANSISTOR		

L: Scandinavia K: USA P: Canada R: Mexico C: China I: Malaysia
Y: PX(Far East, Hawaii) T: Europe E: Europe G: Germany V: China (Shanghai) B: BLACK S: SILVER H: GRAY
Y: AAFES(Europe) X: Australia Q: Russia H: Korea M: Other Areas Δ indicates safety critical components.

* New Parts
Parts without **Parts No.** are not supplied.
Les articles non mentionnés dans le **Parts No.** ne sont pas fournis.
Teile ohne **Parts No.** werden nicht geliefert.

16

Ref. No	Add-ress	New Parts	Parts No.	Description	Desti-nation	Re-marks
Q513			DTA144ES	TRANSISTOR		
Q611			2SC945	TRANSISTOR		
Δ Q701,702			2SD882(Q,P)	TRANSISTOR	K1P1	
Δ Q703			2SC2001L	TRANSISTOR		
Δ Q704			2SD882(Q,P)	TRANSISTOR		
Q705			2SA733	TRANSISTOR		
Q706			2SC945	TRANSISTOR		
Q707			DTC124ES	TRANSISTOR		
Q708			DTC114TS	TRANSISTOR		
Q709			2SA953(K)	TRANSISTOR		
Q711			DTA144ES	TRANSISTOR		
Q713,714			2SC2878A	TRANSISTOR		
DISPLAY UNIT						
LC601			B38-0174-08	LCD DISPLAY		
LP601-603		*	B30-2539-08	PILOT LAMP		
C601		*	C91-1525-08	CERAMIC	0.1UF	Z
C603			C90-3824-08	ELECTRO	4700UF	5.5WV
C604		*	CK45FB1E223Z	CERAMIC	0.022UF	Z
C605			CE04KW1C470M	ELECTRO	47UF	16WV
C606			C91-1525-08	CERAMIC	0.1UF	Z
C607			CE04KW1H2R2M	ELECTRO	2.2UF	50WV
C608			CE04KW1H010M	ELECTRO	1.0UF	50WV
C609			C91-1525-08	CERAMIC	0.1UF	Z
C610			CE04KW1H100M	ELECTRO	10UF	50WV
C611			CK45FB1E223Z	CERAMIC	0.022UF	Z
C612,613			CC45CH1H200J	CERAMIC	20PF	J
C614			C91-1525-08	CERAMIC	0.1UF	Z
C615,616			C91-0749-05	CERAMIC	220PF	K
C617			CK45FB1H101K	CERAMIC	100PF	K
C618			CE04KW1H100M	ELECTRO	10UF	50WV
C619-621			C91-0749-05	CERAMIC	220PF	K
C622			CE04KW1H010M	ELECTRO	1.0UF	50WV
C623			CE04KW1A101M	ELECTRO	100UF	10WV
C624-628			C91-0749-05	CERAMIC	220PF	K
C629			CE04KW1A101M	ELECTRO	100UF	10WV
C631			CE04KW1A330M	ELECTRO	33UF	10WV
C632			C91-0749-05	CERAMIC	220PF	K
CN09		*	E40-8338-08	FFC PIN ASSY(18P)		
CN401		*	E40-8337-08	PIN ASSY 17P		
L601		*	L33-0521-08	CHOCOIL		
X601		*	L77-2244-08	CRYSTAL		
VR603		*	T99-0616-08	VR ENCODER		
SW601-617			S70-0036-08	TACT SWITCH		
SW618-626			S70-0036-08	TACT SWITCH		
D601			1SS133T-77	DIODE		
D602			1N4148	DIODE		
D603,604			1SS133T-77	DIODE		
D607			1SS133T-77	DIODE		
D607			1SS133T-77	DIODE		
D607			1SS133T-77	DIODE		
D607			1SS133T-77	DIODE		
D607			1SS133T-77	DIODE		
D613		*	1SS133T-77	DIODE		
D613		*	B30-2540-08	LED		

L: Scandinavia K: USA P: Canada R: Mexico C: China I: Malaysia
Y: PX(Far East, Hawaii) T: Europe E: Europe G: Germany V: China (Shanghai) B: BLACK S: SILVER H: GRAY
Y: AAFES(Europe) X: Australia Q: Russia H: Korea M: Other Areas Δ indicates safety critical components.

PARTS LIST

RXD-251/301/351/371S/A3

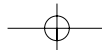

* New Parts
 Parts without **Parts No.** are not supplied.
 Les articles non mentionnés dans le **Parts No.** ne sont pas fournis.
 Teile ohne **Parts No.** werden nicht geliefert.



Ref. No	Add-ress	New Parts	Parts No.	Description	Desti-nation	Re-marks
D613		*	B30-2540-08	LED	E4T1T2	
D613		*	B30-2540-08	LED	M1M2M3	
D613		*	B30-2540-08	LED	Q1Q2Y1	
D613		*	B30-2540-08	LED	X1X2X3	
IC601		*	LC867224A-5H71	IC		
Q601,602			2SC945	TRANSISTOR		
Q603			2SA733	TRANSISTOR	E1E2E3	
Q603			2SA733	TRANSISTOR	E4T1T2	
Q603			2SA733	TRANSISTOR	M1M2M3	
Q603			2SA733	TRANSISTOR	Q1Q2Y1	
Q603			2SA733	TRANSISTOR		
Q604			2SA733	TRANSISTOR	X1X2X3	
RM601		*	W02-2680-08	REMOTE RECEIVER		
SPEAKER						
-		*	B06-0057-08	GRILLE ASSY(BLACK L)	E3E4	B
-		*	B06-0057-08	GRILLE ASSY(BLACK L)	T2Q2X3	B
-		*	B06-0058-08	GRILLE ASSY(BLACK R)	E3E4	B
-		*	B06-0058-08	GRILLE ASSY(BLACK R)	T2Q2X3	B
-		*	B06-0059-08	GRILLE ASSY(GRAY L)	E1E2T1	H
-		*	B06-0059-08	GRILLE ASSY(GRAY L)	K1P1Y1	H
-		*	B06-0059-08	GRILLE ASSY(GRAY L)	M1M2X1	H
-		*	B06-0059-08	GRILLE ASSY(GRAY L)	Q1	H
-		*	B06-0060-08	GRILLE ASSY(GRAY R)	E1E2T1	H
-		*	B06-0060-08	GRILLE ASSY(GRAY R)	K1P1Y1	H
-		*	B06-0060-08	GRILLE ASSY(GRAY R)	M1M2X1	H
-		*	B06-0060-08	GRILLE ASSY(GRAY R)	Q1	H
-		*	H50-2991-08	ITEM CARTON CASE(LS-N301)	E3E4T2	
-		*	H50-2991-08	ITEM CARTON CASE(LS-N301)	Q2	
-		*	H50-2997-08	ITEM CARTON CASE(LS-N351)	E2M3	
-		*	H50-2997-08	ITEM CARTON CASE(LS-N351)	T1E1Q1	
-		*	H50-2998-08	ITEM CARTON CASE(LS-N371S)	M1M2	
-		*	T03-0505-08	TWEETER UNIT(MULTIPLE)		
-		*	T10-1004-08	WOOFER UNIT(40W SINCH)		
-		*	T10-1005-08	WOOFER UNIT(60W 6.5INCH)		
-		*	W03-5839-05L	SPEAKER(LS-N301)LEFT	E3E4	
-		*	W03-5839-05R	SPEAKER(LS-N301)RIGHT	E3E4	
-		*	W03-5839-05L	SPEAKER(LS-N301)LEFT	T2Q2X3	
-		*	W03-5839-05R	SPEAKER(LS-N301)RIGHT	T2Q2X3	
-		*	W03-5840-05L	SPEAKER(LS-N351)LEFT	K1P1Q1	
-		*	W03-5840-05R	SPEAKER(LS-N351)RIGHT	K1P1Q1	
-		*	W03-5840-05L	SPEAKER(LS-N351)LEFT	T1E1E2	
-		*	W03-5840-05R	SPEAKER(LS-N351)RIGHT	T1E1E2	
-		*	W03-5840-05L	SPEAKER(LS-N351)LEFT	X2M3	
-		*	W03-5840-05R	SPEAKER(LS-N351)RIGHT	X2M3	
-		*	W03-5841-05L	SPEAKER(LS-N371)LEFT	M1X1Y1	
-		*	W03-5841-05R	SPEAKER(LS-N371)RIGHT	M1X1Y1	
-		*	W03-5841-05L	SPEAKER(LS-N371)LEFT	M2	
-		*	W03-5841-05R	SPEAKER(LS-N371)RIGHT	M2	

L : Scandinavia K : USA P : Canada R : Mexico C : China I : Malaysia
 Y : PX(Far East, Hawaii) T : Europe E : Europe G : Germany V : China (Shanghai) B : BLACK S : SILVER H : GRAY
 Y : AAFES(Europe) X : Australia Q : Russia H : Korea M : Other Areas Δ indicates safety critical components.



HOW TO READ THE PARTS LIST

ABBREVIATION OF MODEL AND MASS PRODUCTION'S DESTINATIONS

MODEL	ABB.	Australia	Canada	China	England	Europe	Germany	Korea	Malaysia
RXD-251	-	X2	-	-	-	-	-	-	-
RXD-301	-	X3	-	-	T2	E3	-	-	-
RXD-301E	-	-	-	-	-	E4	-	-	-
RXD-301W	-	-	-	-	-	-	-	-	-
RXD-351	-	X1	-	-	T1	E1	-	-	-
RXD-351E	-	-	-	-	-	E2	-	-	-
RXD-351W	-	-	-	-	-	-	-	-	-
RXD-371S	-	-	-	-	-	-	-	-	-
RXD-A3	-	-	P1	-	-	-	-	-	-

MODEL	ABB.	Mexico	PX/AAFES	Russia	Scandinavia	Shanghai	USA	Other area
RXD-251	-	-	-	-	-	-	M3	-
RXD-301	-	-	-	-	-	-	-	-
RXD-301E	-	-	-	-	-	-	-	-
RXD-301W	-	-	-	Q2	-	-	-	-
RXD-351	-	-	Y1	-	-	-	M1	-
RXD-351E	-	-	-	-	-	-	-	-
RXD-351W	-	-	-	Q1	-	-	-	-
RXD-371S	-	-	-	-	-	-	M2	-
RXD-A3	-	-	-	-	-	-	K1	-

Note :

Every individual parts is not available for repair parts on cassette and cd mechanisms.

Schematic is printed to check cd-circuitry, however, no parts list in this manual.



RXD-251/301/351/371S/A3

SPECIFICATIONS

Main unit

[Amplifier section]

(XD-A3)

Rated power output (U.S.A. and Canada)

30 watts per channel minimum RMS, both channels driven, at 6 Ω from 40 Hz to 14 kHz with no more than 0.9 % total harmonic distortion.

Effective output power during STEREO operation

(U.S.A. and Canada)

1 kHz, 10 % T.H.D., 6 Ω 40 W + 40 W

(XD-251/XD-301)

Effective output power during STEREO operation

1 kHz, 10 % T.H.D., 6 Ω 40 W + 40 W

Rated output power during STEREO operation

(Europe, U.K. and Russia)

(DIN) 1 kHz, 0.7 % T.H.D., 6 Ω 30 W + 30 W

(other countries)

1 kHz, 1.0 % T.H.D., 6 Ω 30 W + 30 W

(XD-351/XD-371S)

Effective output power during STEREO operation

(Europe, U.K. and Russia)

1 kHz, 10 % T.H.D., 6 Ω 40 W + 40 W

(other countries)

1 kHz, 10 % T.H.D., 6 Ω 60 W + 60 W

Rated output power during STEREO operation

(Europe, U.K. and Russia)

(DIN) 1 kHz, 0.7 % T.H.D., 6 Ω 30 W + 30 W

(other countries)

1 kHz, 1.0 % T.H.D., 6 Ω 40 W + 40 W

Input sensitivity / impedance

AUX 300 mV / 40 k Ω

(XD-351/XD-371S)

MIC 1, 2 (Except for some areas) 2.5 mV / 2.2 k Ω

Input level / impedance

(XD-A3)

SUPER WOOFER PREOUT 1.8 V / 0.6 k Ω

[Tuner section]

Tuner section

Operating frequency range 87.5 MHz ~ 108 MHz

(For Russia) 87.5 MHz ~ 108 MHz

(65.0 MHz ~ 74.0 MHz

(MW) Tuner section

Operating frequency range

(Europe, U.K. and Russia) 531 kHz ~ 1,602 kHz

(U.S.A. and Canada) 530 kHz ~ 1,700 kHz

(other countries)

9 kHz step 531 kHz ~ 1,602 kHz

10 kHz step 530 kHz ~ 1,610 kHz

Tuner section (For U. K.)

Operating frequency range 153 kHz ~ 279 kHz

Tuner section (XD-371S)

Operating frequency range 5.95 MHz ~ 17.9 MHz

[Cassette deck section]

Track 4-track, 2-channel stereo

Recording system AC bias system
(Frequency: 105 kHz)

Heads

A deck Playback / recording head 1

Erasing head 1

B deck Playback head 1

Motor 1

Fast winding time Approx. 100 seconds
(C-60 tape)

[CD player section]

Laser Semiconductor laser

Wow & Flutter Less than unmeasurable Limit

[General]

Power consumption (XD-A3/XD-251/XD-301) 150 W

(XD-351 for Europe 5and U.K.) 150 W

(XD-351 for other countries) 180 W

(XD-371S) 180 W

Dimensions W: 280 mm (11")

H: 320 mm (12-5/8")

D: 405 mm (15-15/16")

Weight (net) (XD-A3/XD-251/XD-301) 6.9kg (15.2 lb)

(XD-351 for Europe and U.K.) 6.9kg (15.2 lb)

(XD-351 for other countries) 9.1kg (20.1 lb)

(XD-371S) 9.1kg (20.1 lb)

Speakers (LS-N301/LS-N351) XD-A3/XD-251/XD-351 (Europe,

U.K. and Russia)

Enclosure Bass-reflex type

Speaker configuration

Woofer 130 mm, cone type

Tweeter 50 mm, cone type

Impedance 6 Ω

Maximum input level 40 W

Dimensions W: 220 mm (8-11/16")

H: 320 mm (12-5/8")

D: 295 mm (11-5/8")

Weight (net) 3.3 kg (7.3 lb) (1 piece)

Speakers (LS-N371) XD-351 (other countries)/XD-371S

Enclosure Bass-reflex type

Speaker configuration

Woofer 160 mm, cone type

Tweeter 50 mm, cone type

Impedance 6 Ω

Maximum input level 60 W

Dimensions W: 220 mm (8-11/16")

H: 320 mm (12-5/8")

D: 295 mm (11-5/8")

Weight (net) 3.7 kg (8.2 lb) (1 piece)



1. KENWOOD follows a policy of continuous advancements in development. For this reason specifications may be changed without notice.
2. Sufficient performance may not be possible at very low temperatures (0°C or less).

ent and circuit are subject to modification to insure best
under differing local conditions. This manual is based on
(E) standard, and provides information on regional circuit
ion through use of alternate schematic diagrams, and infor-
n regional component variations through use of parts list.

KENWOOD CORPORATION

14-6,Dogenzaka 1-chome, Shibuya-ku, Tokyo, 150-8501 Japan

KENWOOD SERVICE CORPORATION

P.O BOX 22745, 2201 East Dominguez St., Long Beach, CA 90801-5745, U.S.A.

KENWOOD ELECTRONICS CANADA INC.

6070 Kestrel Road, Mississauga, Ontario, Canada L5T 1S8

KENWOOD ELECTRONICS LATIN AMERICA S.A.

P.O BOX 55-2791, Piso 6 plaza Chase, Cl. 47 y Aquilino de la Guardia Panama, Republic de Panama

KENWOOD ELECTRONICS BRASIL LTDA.

Av Indianópolis, 628, 04062-001 Planalto Paullsta São Paulo-SP-Brasil

KENWOOD ELECTRONICS U.K. LIMITED

KENWOOD House, Dwight Road, Watford, Herts., WD1 8EB., United Kingdom

KENWOOD ELECTRONICS BELGIUM N.V.

Meachelsesteenweg 418, B-1930 Zaventem, Belgium

KENWOOD ELECTRONICS DEUTSCHLAND GMBH

Rembrücker Str. 15, 63150 Heusenstamm, Germany

KENWOOD ELECTRONICS FRANCE S.A.

13 Boulevard Ney, 75018 Paris, France

KENWOOD ELECTRONICS ITALIA S.p.A.

Via G. Sirtori, 7/9 20129, Milano, Italy

KENWOOD IBÉRICA S.A.

Bolivia, 239-08020 Barcelona, Spain

KENWOOD ELECTRONICS AUSTRALIA PTY. LTD.

(A.C.N. 001499 074)

P.O Box 504, 8 Figtree Drive, Australia Centre, Homebush, N.S.W. 2140, Australia

KENWOOD & LEE ELECTRONICS, LTD.

Unit 3712-3724, Level 37, Tower 1, Metroplaza, 223 Hing Fong Road, Kwai Fong N.T., Hong Kong

KENWOOD ELECTRONICS GULF FZE

P.O.Box 61318, Jebel Ali, Dubai, U.A.E.

KENWOOD ELECTRONICS SINGAPORE PTE LTD.

No. 1 Genting Lane #02-02, KENWOOD Building, Singapore, 349544

KENWOOD ELECTRONICS (MALAYSIA) SDN BHD.

#4.01 Level 4, Wisma Academy Lot 4A, Jalan 19/1 46300 Petaling Jaya Selangor Darul Ehsan
Malaysia

KENWOOD ELECTRONICS (THAILAND) CO., LTD.

573/111 Soi Ramkhamhaeng 39, Ramkhamhaeng Road, Wangthonglang, Bangkok, Bangkok
10301 Thailand

