

SERVICE MANUAL

COMPACT DISC STEREO
CASSETTE RECEIVER

BASIC TAPE MECHANISM : ZZM-2 PR1NM
BASIC CD MECHANISM : AZG-1 ZA3RNDM

SYSTEM	CD CASSEIVER	SPEAKER	REMOTE CONTROLLER
NSX-BL14	CX-NBL14	SX-NBL11	RC-ZAS02

- This Service Manual is the "Revision Publishing" and replaces "Simple Manual" NSX-BL14(HT,G), (S/M Code No. 09-006-428-8T5).
- If requiring information about the CD mechanism, see Service Manual of AZG-1 (S/M Code No. 09-001-335-3NC).

aiwa
S/M Code No. 09-007-428-8R4

REVISION
DATA

SPECIFICATIONS

<FM tuner section>

Tuning range	87.5 MHz to 108 MHz
Usable sensitivity (IHF)	HT: 13.2 dBf G: 16.8 dBf
Antenna terminals	75 ohms (unbalanced)

<AM/MW tuner section>

Tuning range	530 kHz to 1710 kHz (10 kHz step) 531 kHz to 1602 kHz (9 kHz step)
Usable sensitivity	350 μ V/m
Antenna	Loop antenna

<LW tuner section><G>

Tuning range	144 kHz to 290 kHz
Usable sensitivity	1400 μ V/m
Antenna	Loop antenna

<SW tuner section><HT>

Tuning range	5.730 MHz to 17.900 MHz
Usable sensitivity	40 μ V (IEC)
Antenna	Wire antenna

<Amplifier section>

Power output	Rated HT: 17 W + 17 W (1 kHz, T.H.D. 1%, 6 ohms) Reference: 20 W + 20 W (1 kHz, T.H.D. 10%, 6 ohms) G: 12 W + 12 W (1 kHz/DIN 45500, T.H.D. 1%, 6 ohms) Reference: 15 W + 15 W (1 kHz/DIN 45324, T.H.D. 10%, 6 ohms)
Total harmonic distortion	G: 0.1% (6 W, 1 kHz, 6 ohms, DIN AUDIO) HT: 0.1% (8 W, 1 kHz, 6 ohms, DIN AUDIO)

Inputs

VIDEO/AUX: 500 mV

Outputs

HT: MIC 1.8 mV(10 kohms)
SPEAKERS: accept speakers of 6 ohms or more
PHONES (stereo jack) : accepts headphones of 32 ohms or more

<Cassette deck section>

Track format	4 tracks, 2 channels stereo
Frequency response	50 Hz - 8000 Hz
Recording system	AC bias
Heads	Deck 1 : Recording/Playback head x 1, erase head x 1 Deck 2 : Playback head x 1

<Compact disc player section>

Laser	Semiconductor laser ($\lambda = 780$ nm)
D-A converter	1 bit dual
Signal-to-noise ratio	85 dB (1 kHz, 0 dB)
Harmonic distortion	0.05 % (1 kHz, 0 dB)

<Speaker system>SX-NBL11

Speaker System	2 way, bass reflex (magnetic shielded type)
Speaker units	Woofer: 120 mm cone type Tweeter: 20 mm cone type
Impedance	6 ohms
Sensitivity	87 dB/W/m
Dimensions (W x H x D)	220 x 324 x 211 mm
Weight	2.0 kg

<General>

Power requirements	HT: 120 V/220-230 V/240 V AC (switchable), 50/60 Hz G: 230 V AC, 50 Hz
Power consumption	HT: 60 W G: 45 W
Power consumption in standby mode	With power-economizing mode off : 14 W With power-economizing mode on : 0.9 W
Dimensions of main unit (W x H x D)	260 x 324 x 348 mm
Weight of main unit	HT: 5.0 kg G: 4.9 kg

• Design and specifications are subject to change without notice.

PROTECTION OF EYES FROM LASER BEAM DURING SERVICING

This set employs laser. Therefore, be sure to follow carefully the instructions below when servicing.

WARNING!!

WHEN SERVICING, DO NOT APPROACH THE LASER EXIT WITH THE EYE TOO CLOSELY. IN CASE IT IS NECESSARY TO CONFIRM LASER BEAM EMISSION. BE SURE TO OBSERVE FROM A DISTANCE OF MORE THAN 30cm FROM THE SURFACE OF THE OBJECTIVE LENS ON THE OPTICAL PICK-UP BLOCK.

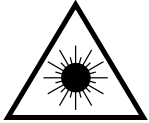

- Caution: Invisible laser radiation when open and interlocks defeated avoid exposure to beam.
- Advarsel: Usynlig laserstråling ved åbning, når sikkerhedsafbrydere er ude af funktion. Undgå udsættelse for stråling.

VAROITUS!

Laiteen Käyttäminen muulla kuin tässä käyttöohjeessa mainitulla tavalla saattaa altistaa käyt-täjän turvallisuusluokan 1 ylittävälle näkymättömälle lasersäteilylle.

WARNING!

Om apparaten används på annat sätt än vad som specificeras i denna bruksanvisning, kan användaren utsättas för osynlig laserstrålning, som överskrider gränsen för laserklass 1.

CAUTION

Use of controls or adjustments or performance of procedures other than those specified herein may result in hazardous radiation exposure.

ATTENTION

L'utilisation de commandes, réglages ou procédures autres que ceux spécifiés peut entraîner une dangereuse exposition aux radiations.

ADVARSEL

Usynlig laserstråling ved åbning, når sikkerhedsafbrydere er ude af funktion. Undgå udsættelse for stråling.

This Compact Disc player is classified as a CLASS 1 LASER product.

The CLASS 1 LASER PRODUCT label is located on the rear exterior.

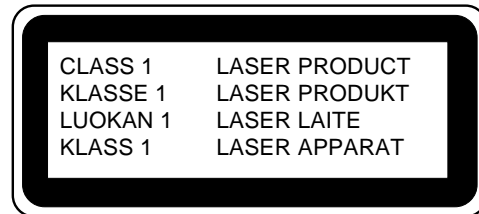

Precaution to replace Optical block

(KSS-213F)

Body or clothes electrostatic potential could ruin laser diode in the optical block. Be sure ground body and workbench, and use care the clothes do not touch the diode.

- 1) After the connection, remove solder shown in right figure.

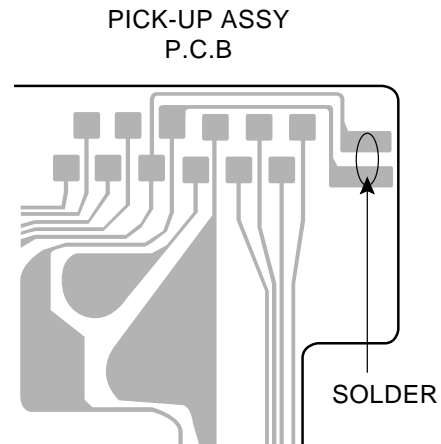

NOTE ON BEFORE STARTING REPAIR

1. Forced discharge of electrolytic capacitor of power supply block

When repair is going to be attempted in the set that uses relay circuit in the power supply block, electric potential is kept charged across the electrolytic capacitors (C101, 102) even though AC power cord is removed. If repair is attempted in this condition, secondary defect can occur.

In order to prevent the secondary trouble, perform the following measures before starting repair work.

Discharge procedure

- ① Remove the AC power cord.
- ② Connect a discharging resistor at an end of lead wire that has clips at both ends. Connect the other end of the lead wire to metal chassis.
- ③ Contact the other end of the discharging resistor to the positive (+) side (+VH) of C101. (For two seconds)
- ④ Contact the same end of the discharging resistor as step ③ to the negative (-) side (-VH) of C102 in the same way. (For two seconds)
- ⑤ Check that voltage across C101 and C102 has decreased to 1 V or less using a multimeter or an oscilloscope.

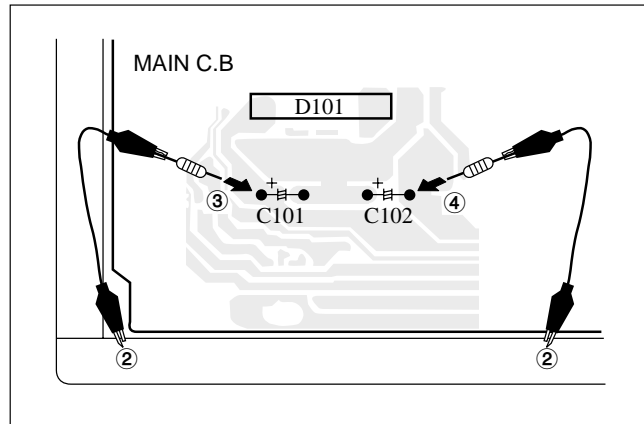

Fig-1

Select a discharging resistor referring to the following table.

Charging voltage (V) (C101, 102)	Discharging resistor (Ω)	Rated power (W)	Parts number
25-48	100	3	87-A00-247-090
49-140	220	5	87-A00-232-090

Note: The reference numbers (C101, C102) of the electrolytic capacitors can change depending on the models. Be sure to check the reference numbers of the charging capacitors on schematic diagram before starting the discharging work.

2. Check items before exchanging the MICROCOMPUTER

Be sure to check the following items before exchanging the MICROCOMPUTER. Exchange the MICROCOMPUTER after confirming that the MICROCOMPUTER is surely defective.

2-1. Regarding the HOLD terminal of the MICROCOMPUTER

When the HOLD terminal (INPUT) of the MICROCOMPUTER is "H", the MICROCOMPUTER is judged to be operating correctly. When this terminal is "L", the main power cannot be turned on. Therefore, be sure to check the terminal voltage of the HOLD terminal before exchange.

When the MICROCOMPUTER is not defective, the HOLD terminal can also go "L" when the POWER AMPLIFIER has any abnormalities that triggers the abnormality detection circuit on the MAIN C. B. that sets the HOLD terminal to "L".

• Good or no good judgement of the MICROCOMPUTER

- ① Turn on the AC main power.
- ② Confirm that the main power is turned on and the HOLD terminal of the MICROCOMPUTER keeps the "H" level or not.
- ③ When the HOLD terminal is "L" level, the abnormality detection circuit is judged to be working correctly and the MICROCOMPUTER is judged to be good.

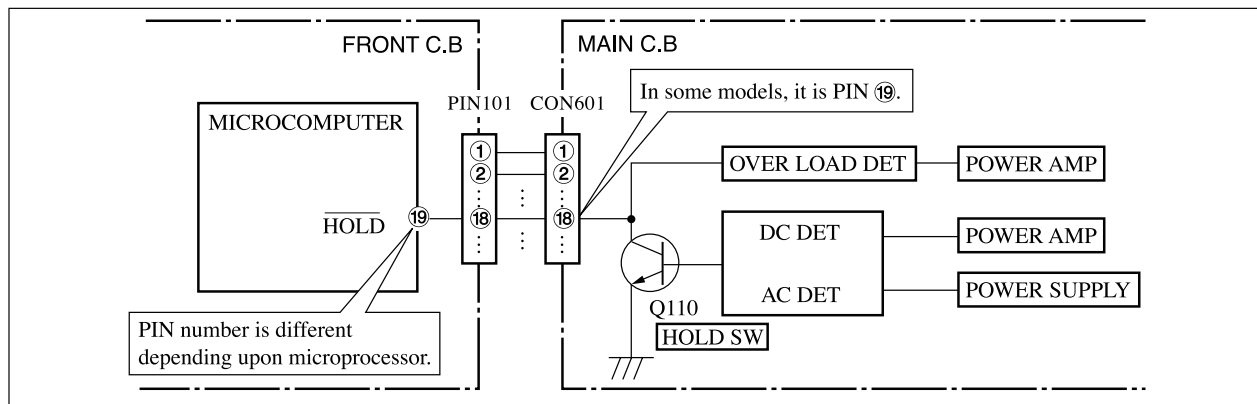

Fig-2-1

In such a case, check also if the POWER AMPLIFIER circuit or power supply circuit has any abnormalities or not.

2-2. Regarding reset

There are cases that the machine does not work correctly because the MICROCOMPUTER is not reset even though the AC power cord is re-inserted, or the software reset (pressing the STOP key + POWER key) is performed.

When the above described phenomenon occurs, it can lead to wrong judgement as if the MICROCOMPUTER is defective and to exchange the MICROCOMPUTER. In such a case, perform the forced-reset by the following procedure and check good or no good of the MICROCOMPUTER.

- ① Remove the AC power cord.

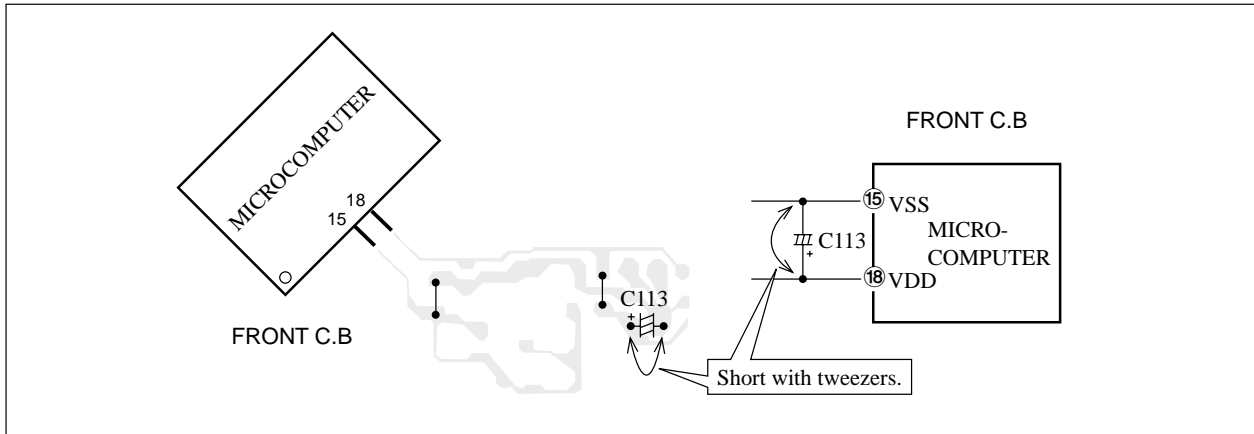

Fig-2-2

- ② Short both ends of the electrolytic capacitor C113 that is connected to VDD of the MICROCOMPUTER with tweezers.
- ③ Connect the AC power cord again. If the MICROCOMPUTER returns to the normal operation, the MICROCOMPUTER is good.

Note: The reference number or MICROCOMPUTER pin number of transistor (Q110) and electrolytic capacitor (C113) can change depending on the models. Be sure to check the reference numbers on schematic diagram before starting the discharging work.

2-3. Confirmation of soldering state of MICROCOMPUTER

Check the soldering state of the MICROCOMPUTER in addition to the above described procedures. Be sure to exchange the MICROCOMPUTER after surely confirming that the trouble is not caused by poor soldering but the MICROCOMPUTER itself.

ELECTRICAL MAIN PARTS LIST

REF. NO.	PART NO.	KANRI NO.	DESCRIPTION	REF. NO.	PART NO.	KANRI NO.	DESCRIPTION
IC				C100	87-018-127-080		CAP TC-U 470P
	8A-NFA-615-010	C-IC,M38B57MCH-E236FP		C101	87-010-185-080		C-CAP,S 3900P-50 KB
	87-A21-419-040	C-IC,NJML14558MD-TE2		C102	87-010-185-080		C-CAP,S 3900P-50 KB
	87-A21-443-040	C-IC,M62495AFP		C103	87-010-545-080		CAP, ELECT 0.22-50V
	87-A21-560-010	IC,LA1844L-A		C104	87-010-545-080		CAP, ELECT 0.22-50V
	87-070-127-110	IC,LC72131 D		C105	87-010-186-080		CAP,CHIP 4700P
	87-A21-629-010	IC,SPS-442-10N		C106	87-010-186-080		CAP,CHIP 4700P
	87-A21-482-010	IC,RPM6938-H4		C107	87-010-403-080		CAP, ELECT 3.3-50V
				C108	87-010-403-080		CAP, ELECT 3.3-50V
				C109	87-010-322-080		C-CAP, S 100P-50JCH
TRANSISTOR				C110	87-010-322-080		C-CAP, S 100P-50JCH
	87-026-609-080	TR,KTA1266GR		C111	87-010-406-080		CAP, ELECT 22-50
	89-213-702-010	TR,2SB1370E		C112	87-010-406-080		CAP, ELECT 22-50
	87-026-610-080	TR,KTC3198GR		C113	87-012-156-080		C-CAP, S 220P-50 J CH<G>
	87-A30-076-080	C-TR,2SC3052F		C113	87-A10-946-080		C-CAP, S 220P-100 J CH<HT>
	87-A30-075-080	C-TR,2SA1235F		C114	87-012-156-080		C-CAP, S 220P-50 J CH<G>
	87-A30-255-010	C-TR,2SB1342		C114	87-A10-946-080		C-CAP, S 220P-100 J CH<HT>
	87-A30-256-010	TR,2SD1933		C119	87-010-197-080		CAP, CHIP 0.01 DM
	87-A30-190-080	TR,CC5551<HT>		C120	87-010-197-080		CAP, CHIP 0.01 DM
	87-026-245-080	TR,DTC114ES<HT>		C123	87-010-197-080		CAP, CHIP 0.01 DM<G>
	87-A30-198-080	TR,KTC3199GR<HT>		C124	87-010-197-080		CAP, CHIP 0.01 DM<G>
	87-A30-090-080	FET,2SK2541		C125	87-010-196-080		CHIP CAPACITOR,0.1-25
	87-A30-484-080	C-TR,KRA102S		C126	87-010-196-080		CHIP CAPACITOR,0.1-25
	87-A30-468-080	C-TR,KRC102S-RTK		C127	87-010-196-080		CHIP CAPACITOR,0.1-25
	87-A30-107-070	C-TR,CMBT5401		C128	87-010-196-080		CHIP CAPACITOR,0.1-25
	87-A30-106-040	C-TR,CMBT5551		C133	87-010-186-080		CAP,CHIP 4700P
	87-A30-091-080	FET,2SJ460		C140	87-010-182-080		C-CAP,S 2200P-50 B
	87-A30-062-080	C-TR,KRC104S		C183	87-010-387-080		CAP,E 470-25 SME<G>
	87-A30-234-080	TR,CSC4115BC		C184	87-010-403-080		CAP, ELECT 3.3-50V<G>
	87-A30-492-080	TR,2SC5343G		C185	87-018-209-080		CAP, TC U 0.1-50ZF<G>
	89-327-143-080	TR,2SC27140		C200	87-018-195-080		CAP TC-U 1200P
	87-A30-489-080	C-TR,KRA107S		C300	87-018-195-080		CAP TC-U 1200P
	89-503-602-080	C-FET,2SK360E<HT>		C301	87-010-179-080		CAP,CHIP S B1200P
	87-A30-086-070	C-TR,CSD1306E<HT>		C302	87-010-179-080		CAP,CHIP S B1200P
	87-A30-495-080	TR,2SA1981Y		C303	87-010-178-080		CHIP CAP 1000P
DIODE				C304	87-010-178-080		CHIP CAP 1000P
	87-020-465-080	DIODE,1SS133 (110MA)		C305	87-010-198-080		CAP, CHIP 0.022
	87-A40-455-080	DIODE,RL203 GW		C307	87-010-263-080		CAP, ELECT 100-10V
	87-A40-553-080	DIODE,1N4003 LES		C308	87-010-263-080		CAP, ELECT 100-10V
	87-A40-774-080	ZENER,UZ24BSD		C309	87-010-311-080		C-CAP, S 12P-50J CH<G>
	87-A40-764-080	ZENER,UZ10BSC		C309	87-010-318-080		C-CAP, S 47P-50J CH<HT>
	87-A40-270-080	C-DIODE,MC2838		C310	87-010-314-080		C-CAP, S 22P-50J CH<G>
	87-A40-269-080	C-DIODE,MC2836		C310	87-010-318-080		C-CAP, S 47P-50J CH<HT>
	87-A40-752-080	ZENER,UZ6.2BSC		C311	87-010-598-080		C-CAP,S 0.068-16VRK
	87-A40-739-080	ZENER,UZ2.7BSA		C312	87-010-598-080		C-CAP,S 0.068-16VRK
	87-017-149-080	ZENER,HZS6A2L		C313	87-010-188-080		CAP,CHIP 6800P
MAIN C.B				C314	87-010-188-080		CAP,CHIP 6800P
C9	87-010-196-080	CHIP CAPACITOR,0.1-25		C315	87-010-263-080		CAP, ELECT 100-10V
C10	87-010-196-080	CHIP CAPACITOR,0.1-25		C317	87-010-546-080		CAP, ELECT 0.33-50V
C11	87-010-196-080	CHIP CAPACITOR,0.1-25		C318	87-010-546-080		CAP, ELECT 0.33-50V
C12	87-010-196-080	CHIP CAPACITOR,0.1-25		C320	87-010-196-080		CHIP CAPACITOR,0.1-25<G>
C21	87-A10-520-000	CAP,E 3300-35 M SMG		C321	87-010-196-080		CHIP CAPACITOR,0.1-25<G>
C22	87-016-051-000	CAP,E 2200-35 SMG		C324	87-010-196-080		CHIP CAPACITOR,0.1-25<G>
C25	87-010-406-080	CAP, ELECT 22-50 M 11L SME<HT>		C325	87-010-196-080		CHIP CAPACITOR,0.1-25<G>
C25	87-010-407-080	CAP, ELECT 33-50 M 11L SME<G>		C326	87-010-198-080		CAP, CHIP 0.022
C26	87-010-406-080	CAP, ELECT 22-50		C327	87-010-196-080		CHIP CAPACITOR,0.1-25
C30	87-010-384-080	CAP, ELECT 100-25M11LSME		C350	87-010-196-080		CHIP CAPACITOR,0.1-25<G>
C31	87-010-263-080	CAP, ELECT 100-10V		C360	87-010-401-080		CAP, ELECT 1-50V
C32	87-010-197-080	CAP, CHIP 0.01 DM		C363	87-010-197-080		CAP, CHIP 0.01 DM<G>
C34	87-010-380-080	CAP, ELECT 47-16		C399	87-012-140-080		CAP 470P
C35	87-010-406-080	CAP, ELECT 22-50		C401	87-010-544-080		CAP, ELECT 0.1-50V
C36	87-010-381-080	CAP, ELECT 330-16V		C402	87-010-544-080		CAP, ELECT 0.1-50V
C38	87-010-190-080	C-CAP,S 0.01-50 ZF		C405	87-010-197-080		CAP, CHIP 0.01 DM
C50	87-010-384-080	CAP, ELECT 100-25 M 11L SME		C406	87-010-197-080		CAP, CHIP 0.01 DM
C60	87-010-403-080	CAP, ELECT 3.3-50V		C407	87-010-197-080		CAP, CHIP 0.01 DM
C61	87-010-380-080	CAP, ELECT 47-16		C408	87-010-197-080		CAP, CHIP 0.01 DM
				C409	87-010-182-080		C-CAP,S 2200P-50 B
				C410	87-010-182-080		C-CAP,S 2200P-50 B
				C411	87-010-405-080		CAP, ELECT 10-50V
				C412	87-010-405-080		CAP, ELECT 10-50V

REF. NO.	PART NO.	KANRI NO.	DESCRIPTION	REF. NO.	PART NO.	KANRI NO.	DESCRIPTION
C452	87-010-382-080		CAP, ELECT 22-25V	C844	87-010-197-080		CAP, CHIP 0.01 DM
C453	87-010-183-080		C-CAP,S 2700P-50 B	C851	87-010-197-080		CAP, CHIP 0.01 DM
C454	87-010-183-080		C-CAP,S 2700P-50 B	C852	87-010-197-080		CAP, CHIP 0.01 DM
C455	87-010-183-080		C-CAP,S 2700P-50 B	C853	87-010-197-080		CAP, CHIP 0.01 DM
C456	87-010-197-080		CAP, CHIP 0.01 DM	C858	87-010-196-080		CHIP CAPACITOR,0.1-25
C458	87-010-178-080		CAP, CHIP 1000P-50KB<G>	C859	87-010-196-080		CHIP CAPACITOR,0.1-25
C459	87-010-175-080		CAP, CHIP 560P-50J SL<G>	C860	87-010-197-080		CAP, CHIP 0.01 DM
C460	87-010-196-080		CHIP CAPACITOR,0.1-25	C940	87-010-197-080		CAP, CHIP S 0.01-25 KB
C461	87-012-158-080		C-CAP,S 390P-50 CH	C942	87-010-149-080		CAP, CHIP S 5P-50 CH<G>
C462	87-012-158-080		C-CAP,S 390P-50 CH	C947	87-010-197-080		CAP, CHIP S 0.01-25 KB
C470	87-018-127-080		CAP, TC U 470P-50 BK	C948	87-012-140-080		CAP, CHIP S 470P-50 JCH
C605	87-010-179-080		CAP,CHIP S B1200P	C952	87-010-197-080		CAP, CHIP S 0.01-25 KB<G>
C606	87-010-179-080		CAP,CHIP S B1200P	C957	87-010-311-080		CAP, CHIP S 12P-50 JCH<G>
C609	87-010-213-080		C-CAP,S 0.015-50 B	C958	87-010-197-080		CAP, CHIP S 0.01-25 KB<G>
C610	87-010-213-080		C-CAP,S 0.015-50 B	C959	87-010-196-080		CHIP CAPACITOR,0.1-25
C611	87-010-545-080		CAP, ELECT 0.22-50V	C960	87-010-196-080		CHIP CAPACITOR,0.1-25
C612	87-010-545-080		CAP, ELECT 0.22-50V	C962	87-010-401-080		CAP, ELECT 1-50V
C613	87-010-545-080		CAP, ELECT 0.22-50V	C963	87-015-785-080		CHIP CAPACITOR, 0.1FZ-25Z
C614	87-010-545-080		CAP, ELECT 0.22-50V	C971	87-010-381-080		CAP, ELECT 330-16V
C615	87-010-154-080		CAP CHIP 10P	C972	87-010-404-080		CAP, ELECT 4.7-50V
C616	87-010-248-080		CAP, ELECT 220-10	C973	87-010-197-080		CAP, CHIP 0.01 DM
C617	87-010-248-080		CAP, ELECT 220-10	C974	87-010-197-080		CAP, CHIP 0.01 DM
C618	87-010-405-080		CAP, ELECT 10-50V	C979	87-010-322-080		C-CAP,S 100P-50 CH
C630	87-016-669-080		C-CAP,S 0.1-25 K B	C982	87-010-196-080		CHIP CAPACITOR,0.1-25
C669	87-010-322-080		C-CAP,S 100P-50 CH<G>	C983	87-010-197-080		CAP, CHIP 0.01 DM
C670	87-010-322-080		C-CAP,S 100P-50 CH<G>	C984	87-010-197-080		CAP, CHIP 0.01 DM
C677	87-010-197-080		CAP, CHIP 0.01 DM	C985	87-010-322-080		CAP, CHIP 100P-50J CH<G>
C771	87-010-263-080		CAP, ELECT 100-10V	C987	87-010-197-080		CAP, CHIP 0.01 DM
C772	87-010-197-080		CAP, CHIP 0.01 DM	C989	87-010-197-080		CAP, CHIP 0.01 DM
C779	87-010-971-080		CAP, CHIP 4700P-50JB<G>	C993	87-010-178-080		CHIP CAP 1000P
C780	87-010-971-080		CAP, CHIP 4700P-50JB<G>	C995	87-010-178-080		CHIP CAP 1000P
C782	87-010-197-080		CAP, CHIP 0.01 DM	C997	87-010-196-080		CHIP CAPACITOR,0.1-25
C783	87-010-197-080		CAP, CHIP 0.01 DM	C999	87-A11-155-080		CAP,TC U 0.01-16 Z F
C784	87-010-197-080		CAP, CHIP 0.01 DM	CF831	87-008-261-010		FILTER, SFE10.7MA5-A<HT>
C785	87-010-197-080		CAP, CHIP 0.01 DM	CF831	87-008-423-010		FILTER, CF SFE10.7MAS3G-A<G>
C786	87-010-197-080		CAP, CHIP 0.01 DM	CF832	87-008-261-010		FILTER, SFE10.7MA5-A<HT>
C788	87-010-149-080		C-CAP,S 5P-50 CH	CF832	82-785-747-010		CF,MS2 GHY,R<G>
C789	87-A10-801-080		C-CAP,S 0.022-16 J B	CN301	87-A60-620-010		CONN,3P V 2MM JMT
C790	87-A10-801-080		C-CAP,S 0.022-16 J B	CN351	87-A60-625-010		CONN,8P V 2MM JMT
C791	87-010-196-080		CHIP CAPACITOR,0.1-25	CN601	87-099-719-010		CONN,30P TYK-B(X)
C792	87-010-197-080		CAP, CHIP 0.01 DM	CN602	87-099-194-010		CONN,6P 6216V
C793	87-010-404-080		CAP, ELECT 4.7-50V	CNA1	8A-NF8-652-010		CONN ASSY,7P TID-A(480)<HT>
C794	87-010-322-080		CAP, CHIP 100P-50J CH<G>	D951	87-A40-618-080		VARI-CAP,SVC 348(S/T)<HT>
C795	87-010-197-080		CAP, CHIP 0.01 DM	FFE831	A8-8ZA-190-030		8ZA-1 FEUNM<HT>
C796	87-010-197-080		CAP, CHIP 0.01 DM	FFE831	A8-6ZA-191-130		6ZA-1 FEENM<G>
C797	87-010-405-080		CAP, ELECT 10-50V	J101	87-A60-602-010		JACK,DIA6.3 BLK ST W/SW TC
C798	87-010-197-080		CAP, CHIP 0.01 DM	J602	87-A60-881-010		JACK,PIN 2P MSP 242V05 PBSN
C799	87-010-407-080		CAP, ELECT 33-50V	J831	87-A60-202-010		TERMINAL,ANT 4P MSP-154V02<HT>
C800	87-012-369-080		C-CAP,S 0.047-50F	J832	87-A60-403-010		TERMINAL,ANT PAL 2P HSP312V05<G>
C801	87-010-403-080		CAP, ELECT 3.3-50V	L101	87-A50-610-010		COIL,1UH-K(MDEC)
C802	87-012-369-080		C-CAP,S 0.047-50F	L102	87-A50-610-010		COIL,1UH-K(MDEC)
C803	87-010-198-080		CAP, CHIP 0.022	L451	87-007-342-010		COIL,OSC 85K BIAS
C804	87-010-263-080		CAP, ELECT 100-10V	L801	87-A50-608-010		COIL,FM DET-N (TOK)
C807	87-010-400-080		CAP, ELECT 0.47-50V	L802	87-A91-551-010		FLTR,PCFUZH-450 L(TOK)
C808	87-010-401-080		CAP, ELECT 1-50V	L811	87-005-847-080		COIL,2.2UH(CECS)
C809	87-010-401-080		CAP, ELECT 1-50V	L832	87-005-847-080		COIL,2.2UH(CECS)
C810	87-010-196-080		CHIP CAPACITOR,0.1-25	L941	87-A50-020-010		COIL,ANT LWCOI<G>
C814	87-010-197-080		CAP, CHIP 0.01 DM	L941	87-A50-022-010		COIL,ANT SWCOI<HT>
C815	87-010-400-080		CAP, ELECT 0.47-50V<HT>	L942	87-A50-019-010		COIL,OSC LWCOI<G>
C815	87-010-403-080		CAP, ELECT 3.3-50V<G>	L942	87-A50-550-010		COIL,OSC SW-2NCOI<HT>
C816	87-010-400-080		CAP, ELECT 0.47-50V<HT>	L943	87-A50-522-080		COIL,1MH K CEC<HT>
C816	87-010-403-080		CAP, ELECT 3.3-50V<G>	L944	87-A50-159-010		COIL,10MH K C2B<HT>
C818	87-010-180-080		CAP, CHIP 1500P-50 KB<G>	L951	8A-NF8-668-010		COIL,AM PACK 2(TOK)<G>
C821	87-010-405-080		CAP, ELECT 10-50V	L952	87-A50-430-010		COIL,ANT MW (3BSW)<HT>
C823	87-010-177-080		C-CAP,S 820P-50 SL<HT>	L953	87-A50-431-010		COIL,OSC MW (3BSW)<HT>
C823	87-012-349-080		C-CAP,S 1000P-50 J CH<G>	R653	87-016-669-080		C-CAP,S 0.1-25 KB
C824	87-010-405-080		CAP, ELECT 10-50V	R654	87-016-669-080		C-CAP,S 0.1-25 KB
C825	87-010-596-080		CAP, S 0.047-16	R790	87-010-197-080		CAP, CHIP 0.01 DM
C831	87-010-406-080		CAP, E 22-50 M 11L<G>	R991	87-010-322-080		C-CAP,S 100P-50 CH
C842	87-010-197-080		CAP, CHIP 0.01 DM	R993	87-010-322-080		C-CAP,S 100P-50 CH

REF. NO.	PART NO.	KANRI NO.	DESCRIPTION	REF. NO.	PART NO.	KANRI NO.	DESCRIPTION
R995	87-010-322-080		C-CAP,S 100P-50 CH	S323	87-A90-164-080		SW,TACT SKQAB (N)
TC941	87-011-254-080		TRIMMER,CER 20P 4.0X4.5 ECR<HT>	S324	87-A90-164-080		SW,TACT SKQAB (N)
TC942	87-011-253-080		TRIMMER,CER 30P 4.0X4.5<G>	S325	87-A90-164-080		SW,TACT SKQAB (N)
TC943	87-011-253-080		TRIMMER,CER 30P 4.0X4.5<HT>	S326	87-A90-164-080		SW,TACT SKQAB (N)
W181	85-NF5-628-010		F-CABLE,7P 2.5<G>	S327	87-A90-164-080		SW,TACT SKQAB (N)
WH1	87-A90-460-010		HLDR,WIRE 2.5-7P	S328	87-A90-164-080		SW,TACT SKQAB (N)
X991	87-A70-061-010		VIB,XTAL 4.500MHZ CSA-309	S329	87-A90-164-080		SW,TACT SKQAB (N)
				S330	87-A90-164-080		SW,TACT SKQAB (N)
				S331	87-A90-164-080		SW,TACT SKQAB (N)
FRONT C.B				SFR701	87-024-431-080		SFR,3.3K RH063EC
C101	87-010-196-080		CHIP CAPACITOR,0.1-25	VR401	87-NB7-602-010		VR,RTRY 10KAX1 1V<HT>
C102	87-012-369-080		C-CAP,S 0.047-50F				
C103	87-010-374-040		CAP, ELECT 47-10				
C104	87-A10-797-040		CAP,E 47-35 M 5L SRM	PT C.B			
C105	87-010-192-080		C-CAP,S 0.022-50 F				
C107	87-010-196-080		CHIP CAPACITOR,0.1-25	C1	87-010-387-080		CAP,E 470-25 SME<HT>
C108	87-010-178-080		CHIP CAP 1000P	C31	87-010-403-080		CAP, ELECT 3.3-50V<HT>
C109	87-012-369-080		C-CAP,S 0.047-50F	C183	87-010-387-080		CAP, ELECT 470-25 M<G>
C110	87-010-197-080		CAP, CHIP 0.01 DM	C184	87-010-403-080		CAP, ELECT 3.3-50V<G>
C111	87-010-196-080		CHIP CAPACITOR,0.1-25	C185	87-018-209-080		CAP, TC U 0.1-50 ZF<G>
C113	87-010-178-080		CHIP CAP 1000P	△ CN1	87-A61-109-010		CONN,7P V TID-A<HT>
C114	87-010-154-080		CAP CHIP 10P	△ PT1	8A-NFA-606-010		PT,ANF-A HR<HT>
C115	87-010-175-080		CAP 560P	△ PT1	8A-NFA-608-010		PT,ANF-A EZ<G>
C116	87-010-400-040		CAP,E 0.47-50	△ PT2	8A-NF8-673-010		PT,SUB ANF-8 (H) KAMI<HT>
C117	87-016-460-080		C-CAP,S 0.22-16 B	△ PT181	8A-NF8-662-010		PT,SUB ANF-8 (E) <G>
C118	87-A10-189-040		CAP,E 220-10	△ RY1	87-A91-281-010		RELAY,AC DC12V OSA-SS-212DM5<HT>
C119	87-A10-189-040		CAP,E 220-10	△ RY181	87-A90-976-010		RELAY,AC12V SDT-S-112LMR<G>
C120	87-012-156-080		C-CAP,S 220P-50 CH	△ S1	87-A90-165-010		SW,SL 1-2-3 SWS2301<HT>
C123	87-010-196-080		CHIP CAPACITOR,0.1-25	△ T1	87-A60-317-010		TERMINAL, 1P MSC<HT>
C124	87-010-196-080		CHIP CAPACITOR,0.1-25	△ T2	87-A60-317-010		TERMINAL, 1P MSC<HT>
C125	87-010-405-040		CAP,E 10-50	△ T181	87-A60-317-010		TERMINAL, 1P MSC<G>
C126	87-010-196-080		CHIP CAPACITOR,0.1-25	△ T182	87-A60-317-010		TERMINAL, 1P MSC<G>
C129	87-010-374-040		CAP,E 47-10	WH181	87-A90-460-010		HLDR,WIRE 2.5-7P<G>
C210	87-012-156-080		C-CAP,S 220P-50 CH				
C212	87-010-404-040		CAP,E 4.7-50 SME				
C213	87-010-404-040		CAP,E 4.7-50 SME				
C401	87-010-186-080		C-CAP,S 4700P-50 K B<HT>				
C402	87-010-060-040		CAP,E 100-16 M 7L SRA<HT>				
C403	87-010-545-040		CAP,E 0.22-50 M 11L SME<HT>				
C404	87-010-322-040		C-CAP,S 100P-50 J CH GRM<HT>				
C405	87-010-545-040		CAP,E 0.22-50 M 11L SME<HT>				
C406	87-016-669-080		C-CAP,S 0.1-25 K B<HT>				
C407	87-010-405-040		CAP,E 10-50 M 11L SME<HT>				
C408	87-010-322-040		C-CAP,S 100P-50 J CH GRM<HT>				
C409	87-010-378-040		CAP,E 10-16 M 11L SME<HT>				
C410	87-010-196-080		C-CAP,S 0.1-25 Z F<HT>				
C412	87-010-177-080		C-CAP,S 820P-50 J SL<HT>				
C701	87-010-384-040		CAP,E 100-25 SME				
C702	87-010-178-080		C-CAP,S1000P-50KB<G>				
CN101	87-099-720-010		CONN,30P TYK-B (P)				
CN701	87-A60-673-010		CONN,9P H 2MM JMT				
CN801	87-099-015-010		CONN,13P 6216V				
EMI401	87-008-372-080		FLTR,EMI BL01 RN1<HT>				
FL201	8A-NFA-604-010		FL,10-BT-224GNK				
J401	87-A61-243-010		JACK,6.3 BLK MONO W/SW V MSC<HT>				
L101	87-A50-434-010		COIL,CLK 4.19M(TOKO)				
LED101	87-A40-317-080		LED,SLR-342VCT31 RED				
S101	87-A91-555-010		SW,RTRY EC12E24504				
S301	87-A90-164-080		SW,TACT SKQAB (N)				
S302	87-A90-164-080		SW,TACT SKQAB (N)				
S303	87-A90-164-080		SW,TACT SKQAB (N)				
S304	87-A90-164-080		SW,TACT SKQAB (N)				
S305	87-A90-164-080		SW,TACT SKQAB (N)				
S306	87-A90-164-080		SW,TACT SKQAB (N)				
S307	87-A90-164-080		SW,TACT SKQAB (N)				
S308	87-A90-164-080		SW,TACT SKQAB (N)				
S309	87-A90-164-080		SW,TACT SKQAB (N)				
S321	87-A90-164-080		SW,TACT SKQAB (N)				
S322	87-A90-164-080		SW,TACT SKQAB (N)				

○チップ抵抗部品コード／CHIP RESISTOR PART CODE

チップ抵抗部品コードの成り立ち

Chip Resistor Part Coding

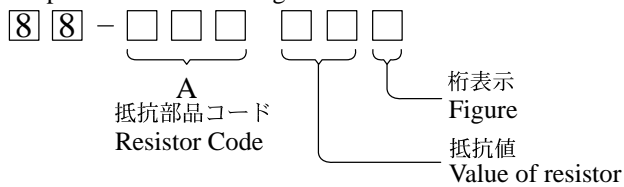

チップ抵抗
Chip resistor

容量 Wattage	種類 Type	許容誤差 Tolerance	記号 Symbol	寸法/Dimensions (mm)			抵抗コード : A Resistor Code : A	
				外形/Form	L	W		t
1/16W	1005	± 5%	CJ		1.0	0.5	0.35	104
1/16W	1608	± 5%	CJ		1.6	0.8	0.45	108
1/10W	2125	± 5%	CJ		2	1.25	0.45	118
1/8W	3216	± 5%	CJ		3.2	1.6	0.55	128

TRANSISTOR ILLUSTRATION



E C B

CSC4115
KTA1266
KTC3198
KTC3199

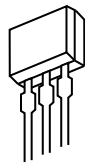

S D G

2SJ460
2SK2541



E C B

DTC114ES



B C E

2SB1342
2SB1370
2SD1933



E B C

2SA1981



E C B

2SC5343
CC5551

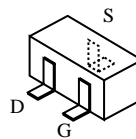

2SK360

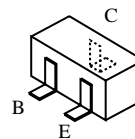

2SA1235
2SC2714
2SC3052
CSD1306
CMBT5401

CMBT5551
KRA102
KRA107
KRC102
KRC104

FL (10-BT-224GNK) GRID ASSIGNMENT AND ANODE CONNECTION
 GRID ASSIGNMENT

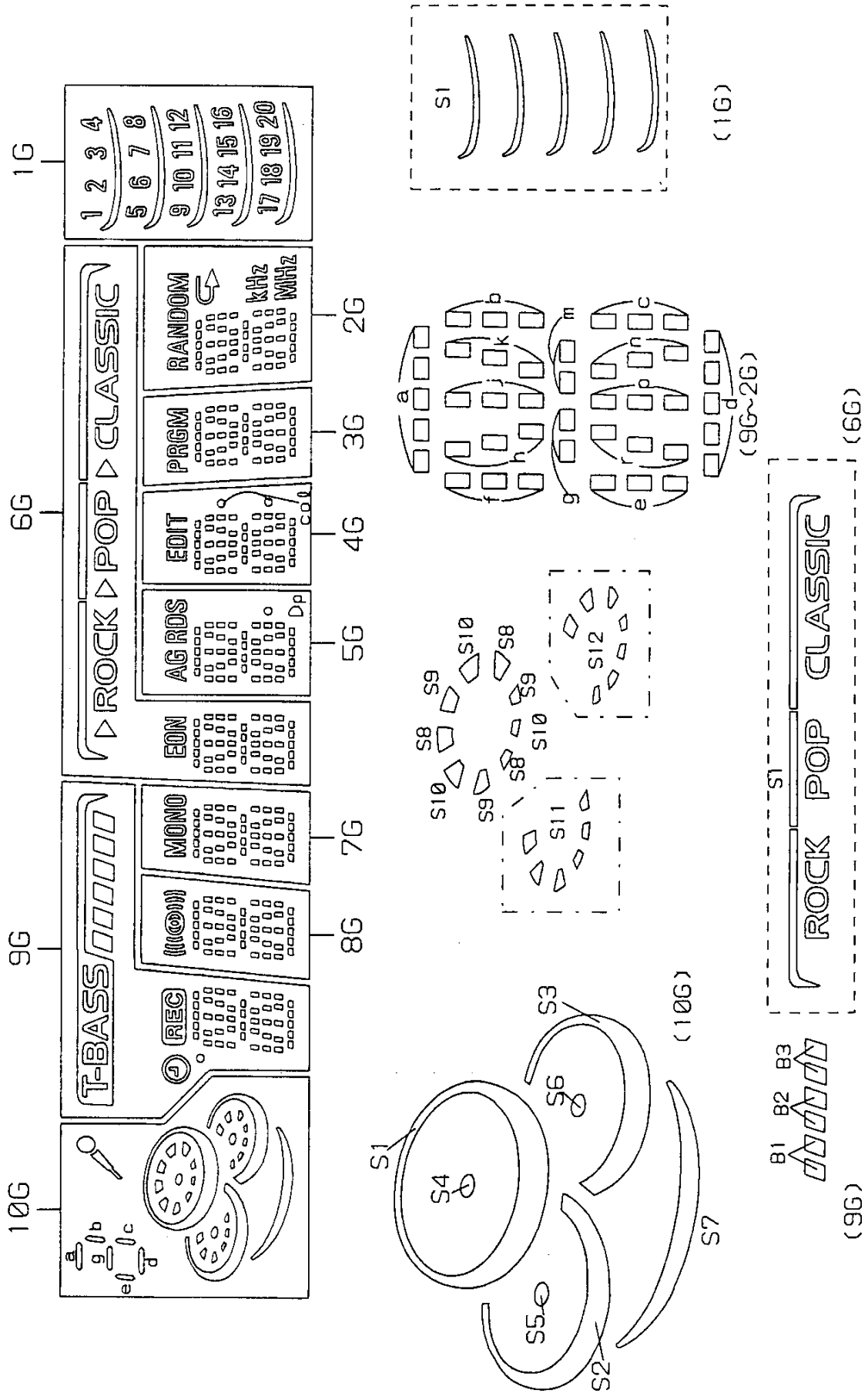

ANODE CONNECTION

	10G	9G	8G	7G	6G	5G	4G	3G	2G	1G
P1	-	d	d	d	d	d	d	d	d	16
P2	S7	n	n	n	n	n	n	n	n	20
P3	-	p	p	p	p	p	p	p	p	19
P4	S11	r	r	r	r	r	r	r	r	18
P5	S5	e	e	e	e	e	e	e	e	17
P6	S2	c	c	c	c	c	c	c	c	16
P7	S12	g	g	g	g	g	g	g	g	15
P8	S6	m	m	m	m	m	m	m	m	14
P9	S3	f	f	f	f	f	f	f	f	13
P10	S10	b	b	b	b	b	b	b	b	12
P11	S9	k	k	k	k	k	k	k	k	11
P12	S8	j	j	j	j	j	j	j	j	10
P13	S4	h	h	h	h	h	h	h	h	9
P14	S1	a	a	a	a	a	a	a	a	8
P15	-	Ⓜ	((()))	MONO	EON	Dp	col (F)	-	MHZ	7
P16	-	REC	-	-	-	AG	col (L)	-	KHZ	6
P17	Ⓜ	○	-	-	△ (CLASSIC)	RDS	EDIT	PRGM	↩	5
P18	a, d, g	CLASS	-	-	△ (ROCK)	-	-	-	-	4
P19	b	B1	-	-	△ (POP)	-	-	-	-	3
P20	c	B2	-	-	S1	-	-	-	RANDOM	2
P21	e	B3	-	-	-	-	-	-	-	1
										S1

WIRING - 1 (MAIN)<HT>

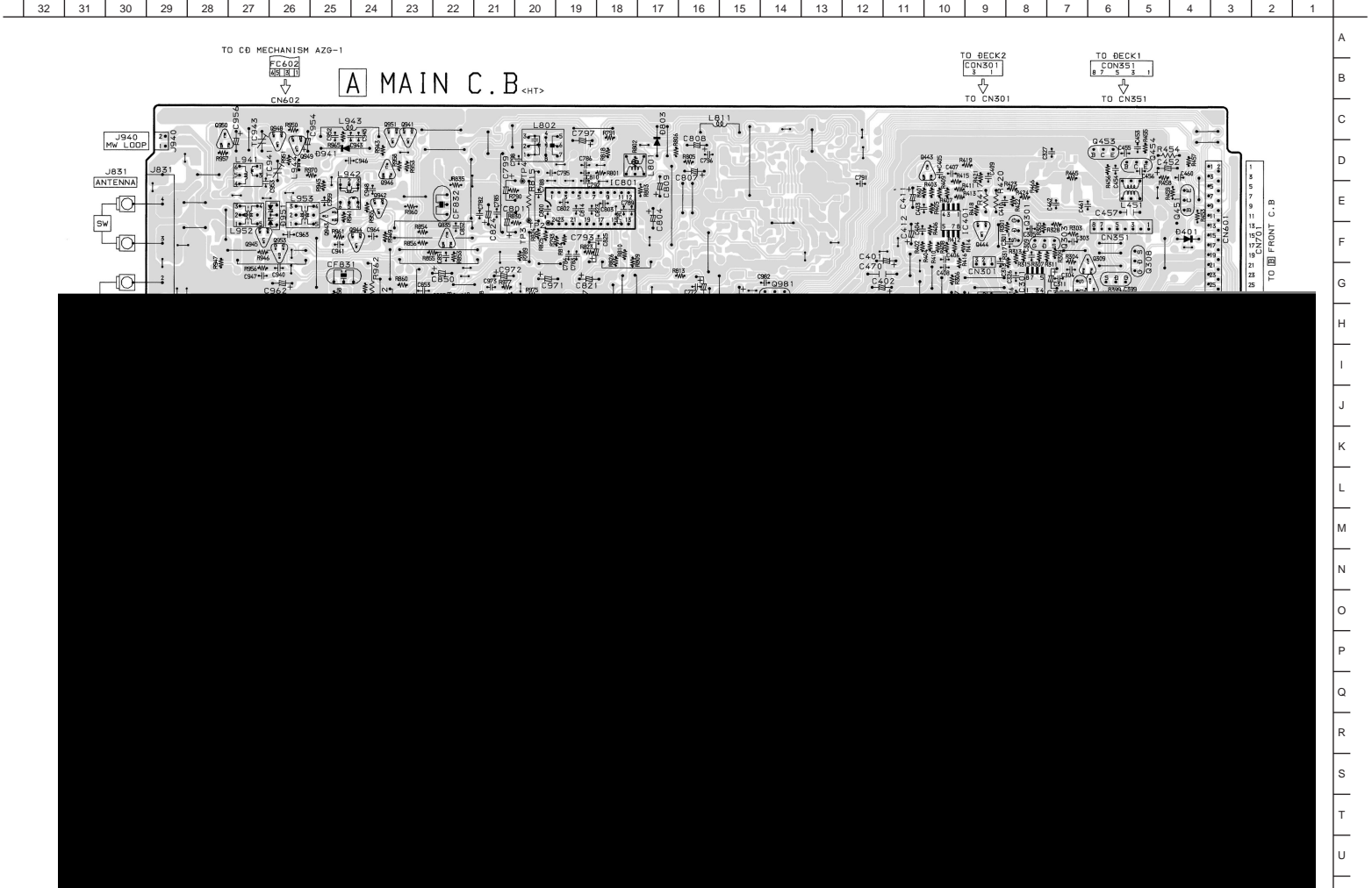

SCHEMATIC DIAGRAM - 1 (MAIN 1/2 : AMP SECTION) <HT>

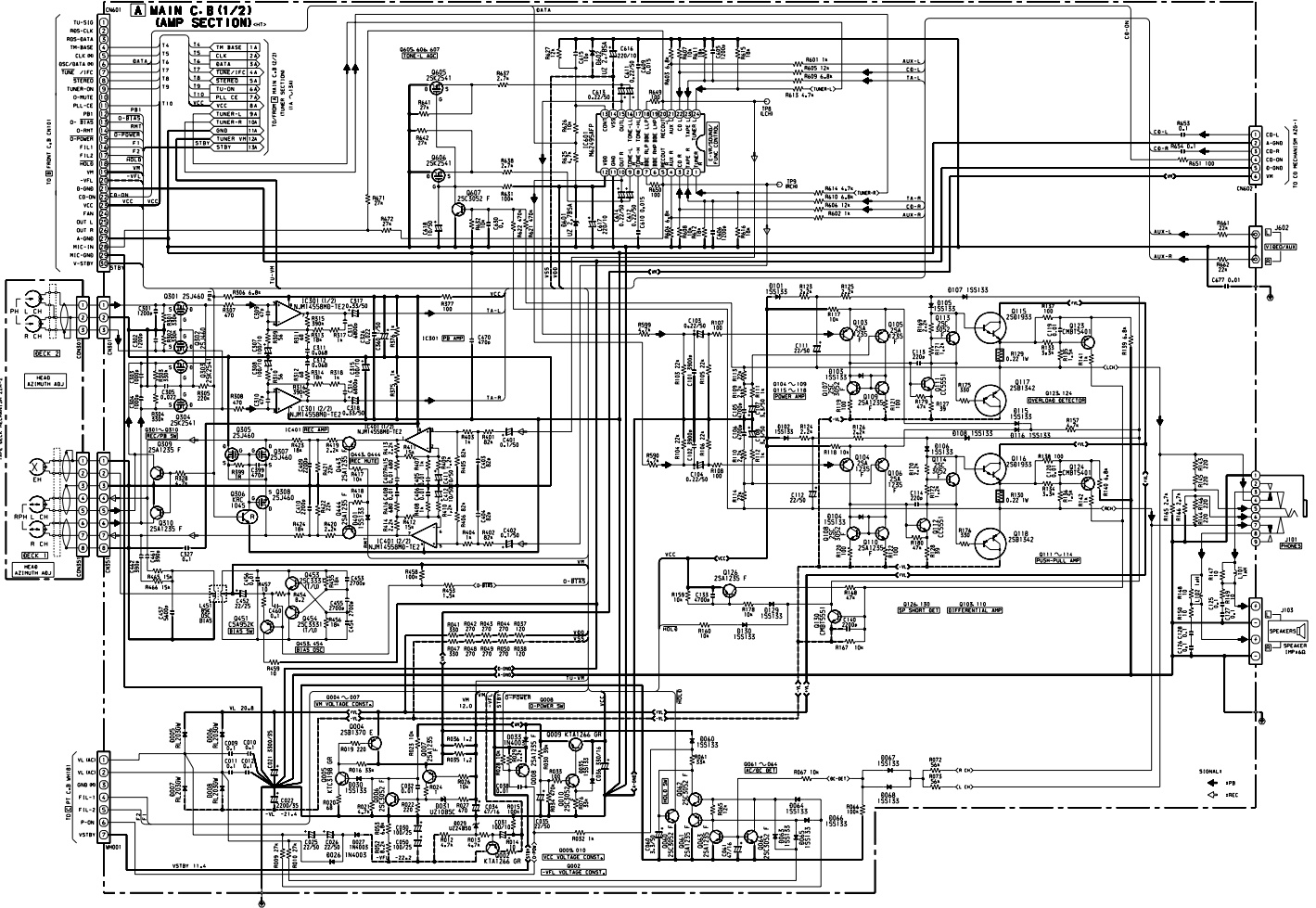

SCHEMATIC DIAGRAM – 2 (MAIN 2 / 2 : TUNER SECTION) <HT>

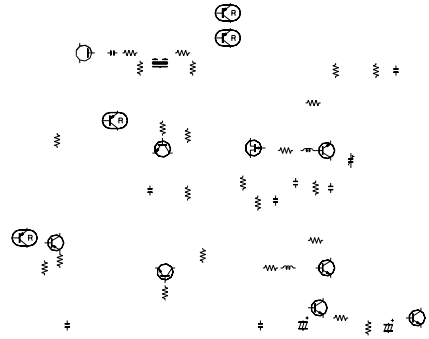
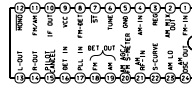
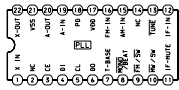

WIRING - 2 (MAIN)<G>

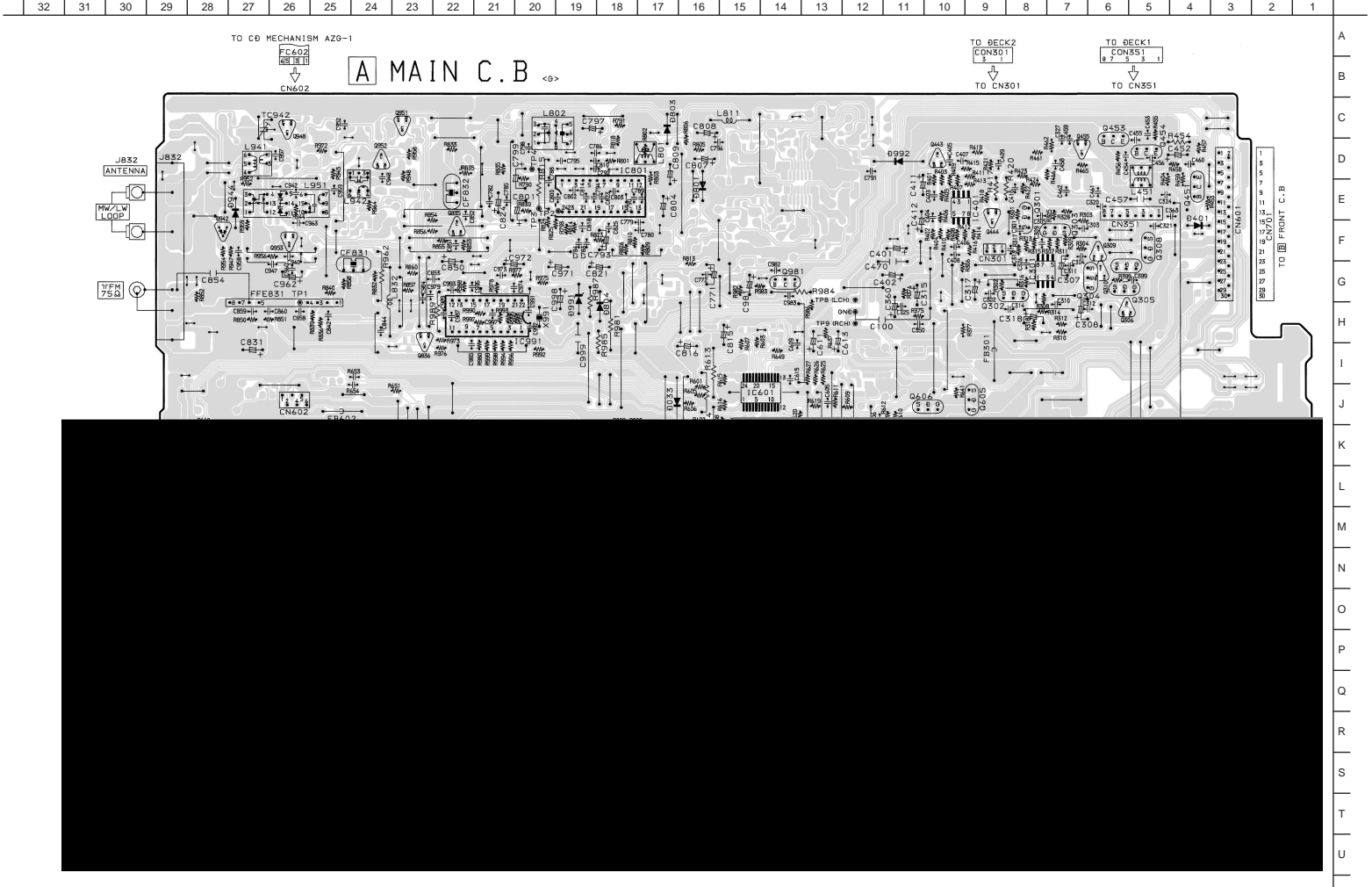

SCHEMATIC DIAGRAM - 3 (MAIN 1/2 : AMP SECTION) <G>

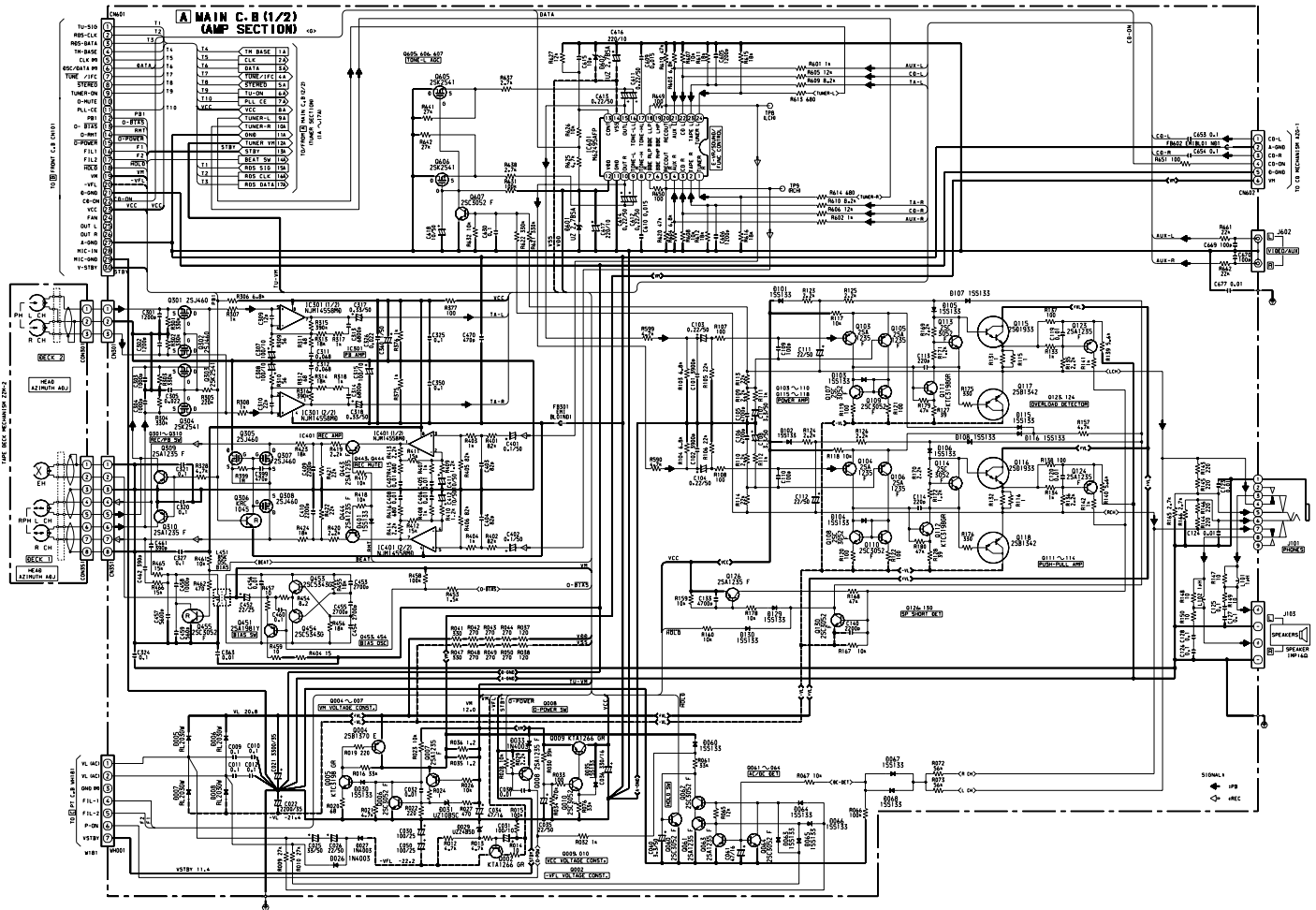

SCHEMATIC DIAGRAM-4 (MAIN 2/2: TUNER SECTION)<G>

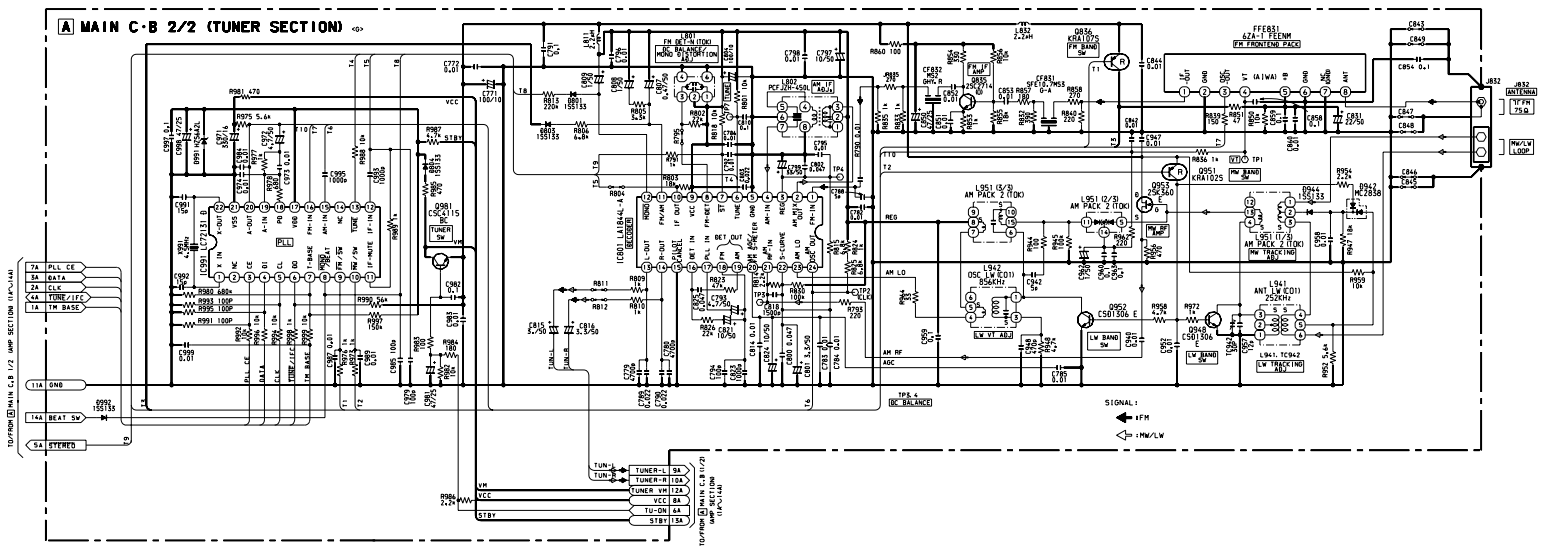

WIRING - 3 (FRONT)<HT>

32	31	30	29	28	27	26	25	24	23	22	21	20	19	18	17	16	15	14	13	12	11	10	9	8	7	6	5	4	3	2	1
----	----	----	----	----	----	----	----	----	----	----	----	----	----	----	----	----	----	----	----	----	----	----	---	---	---	---	---	---	---	---	---

TO CB MECHANISM AZ0-1

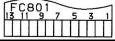

B FRONT C. B

<HT>

FL201
(DISPLAY)

LEP101
(STANDBY)

IC102
(REMOTE SENSOR)

SZ01
(POWER)

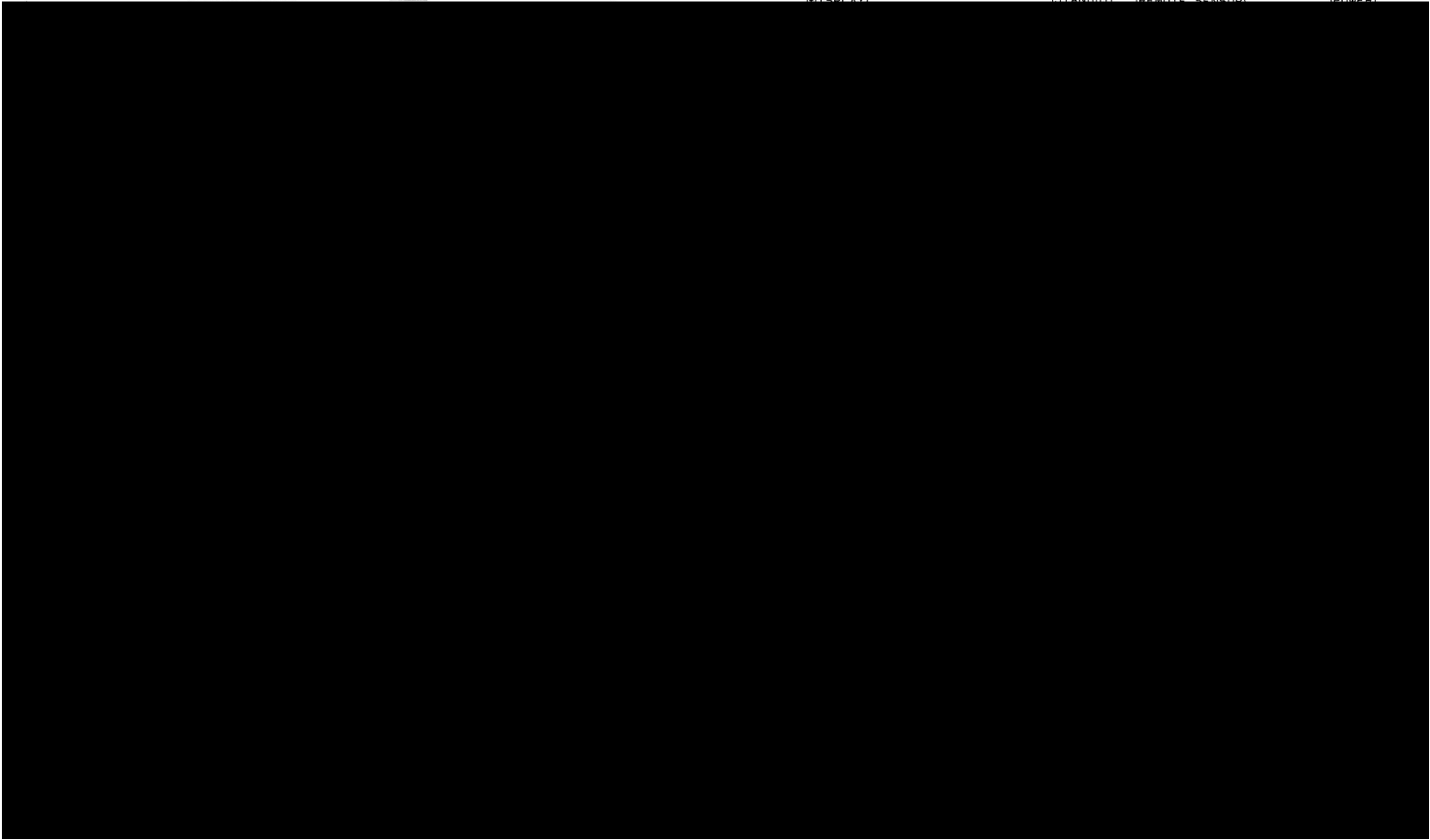

A
B
C
D
E
F
G
H
I
J
K
L
M
N
O
P
Q
R
S
T
U

SCHEMATIC DIAGRAM - 5 (FRONT) <HT>

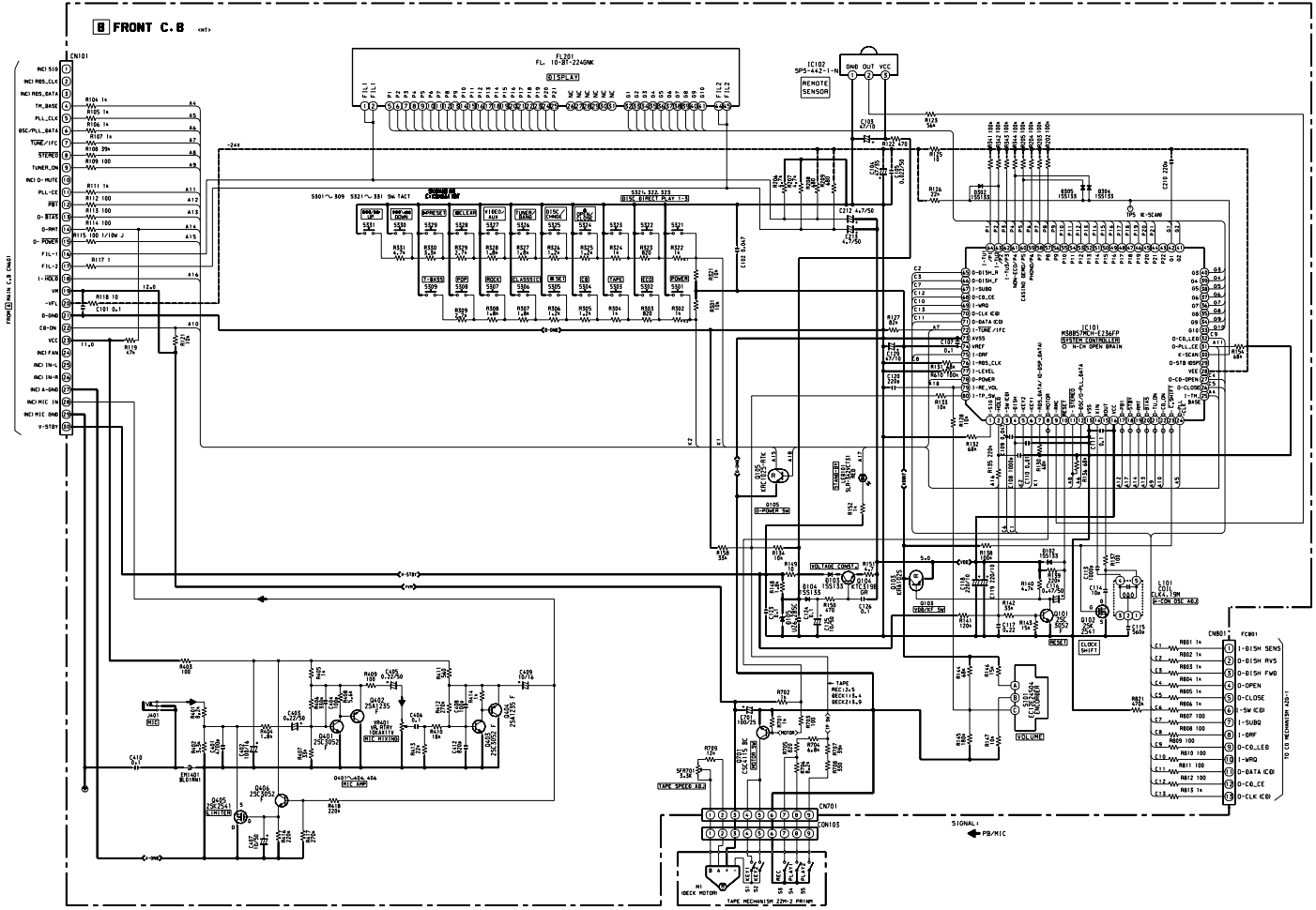

WIRING - 4 (FRONT)<G>

32 31 30 29 28 27 26 25 24 23 22 21 20 19 18 17 16 15 14 13 12 11 10 9 8 7 6 5 4 3 2 1

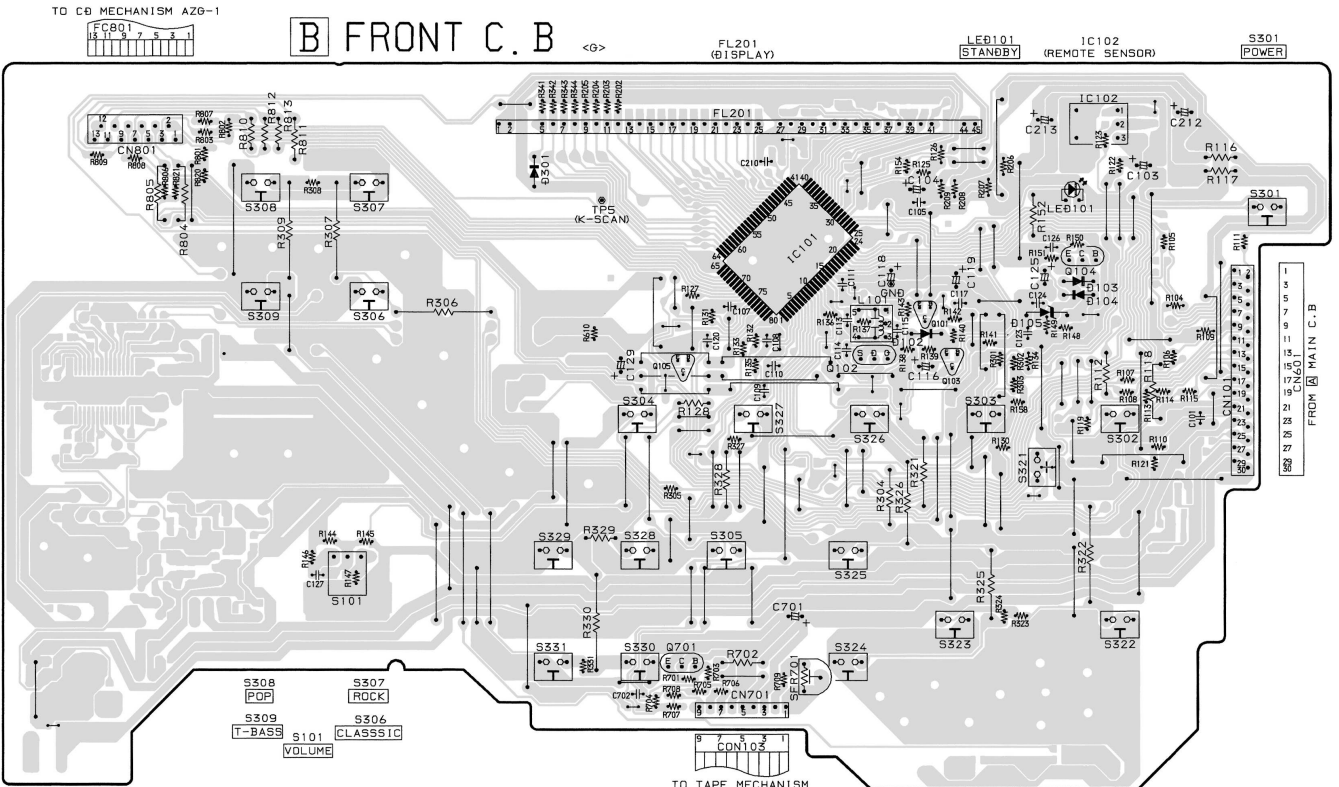

S308 POP
S309 T-BASS
S101 VOLUME
S307 ROCK
S306 CLASSIC

TO TAPE MECHANISM ZM-2 PR1NM

S304 [C] VIDEO/AUX
S328 [] CLEAR
S331 [] UP
S327 [] SET
S305 [] DISC/CHANGE
S330 [] DOWN
S326 [] TUNER/BAND
S325 [] DISC/CHANGE
S324 [] OPEN/CLOSE
S303 [] TAPE
S302 [] EJECT
S321, S322, S323 [] DISC DIRECT PLAY 1-3

A
B
C
D
E
F
G
H
I
J
K
L
M
N
O
P
Q
R
S
T
U

WIRING - 5 (PT)<HT>

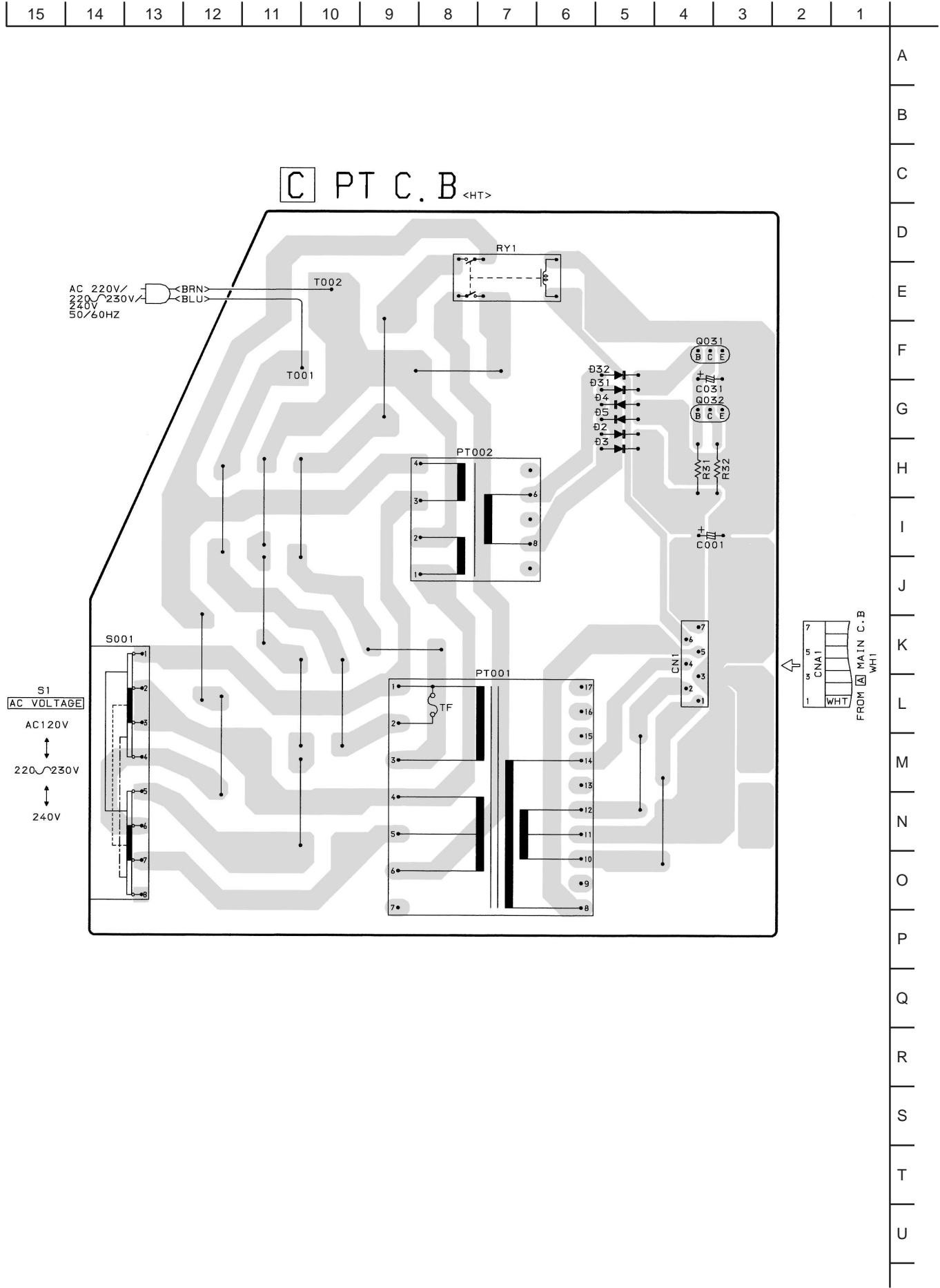

SCHEMATIC DIAGRAM -7 (PT)<HT>

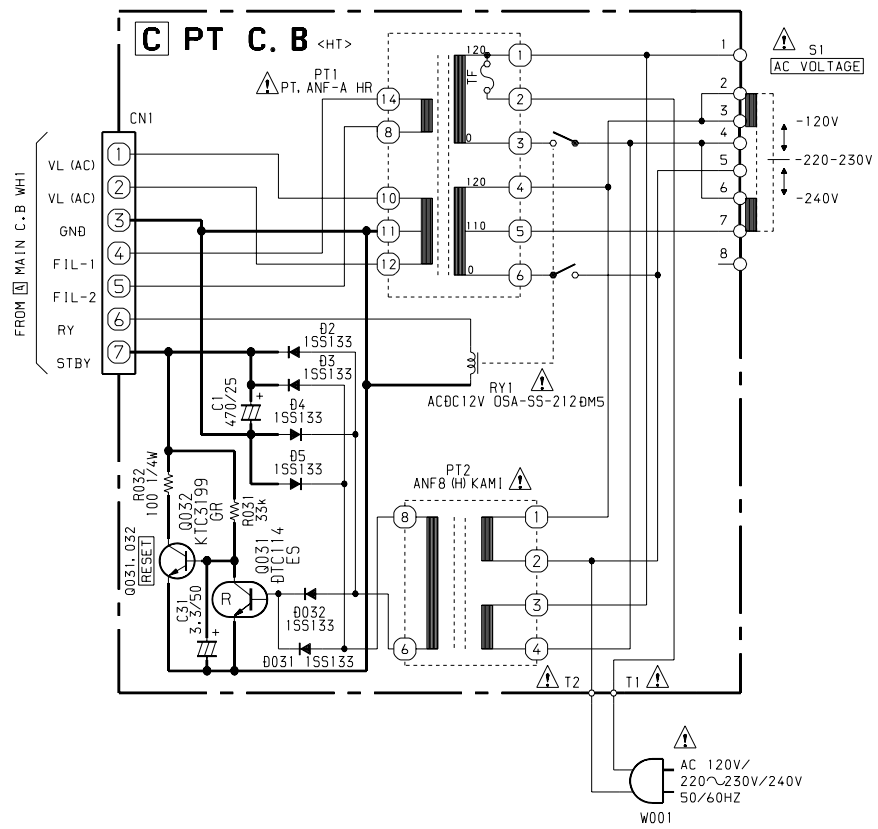

WIRING - 6 (PT)<G>

15	14	13	12	11	10	9	8	7	6	5	4	3	2	1
----	----	----	----	----	----	---	---	---	---	---	---	---	---	---

A
B
C
D
E
F
G
H
I
J
K
L
M
N
O
P
Q
R
S
T
U

C PT C.B <G>

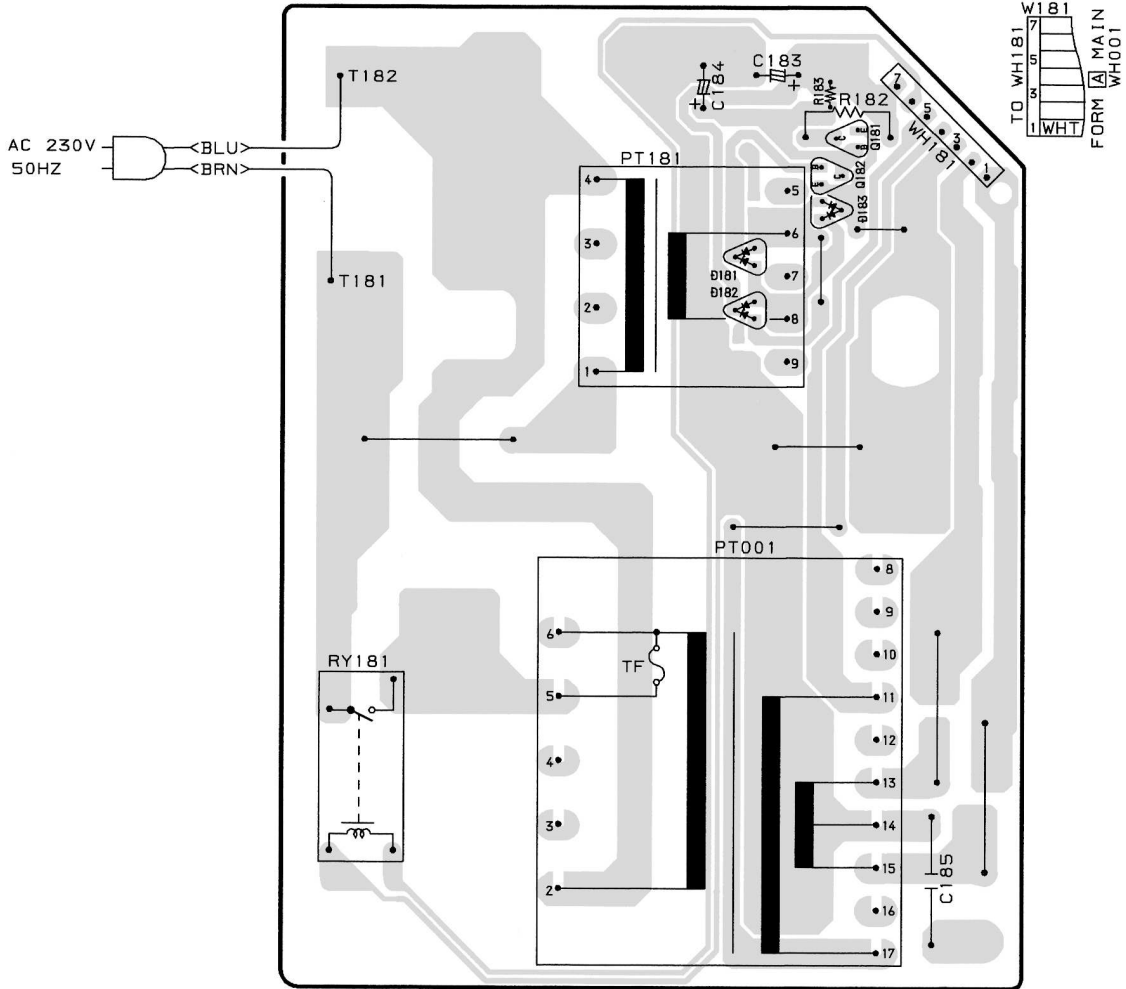

SCHEMATIC DIAGRAM - 8 (PT)<G>

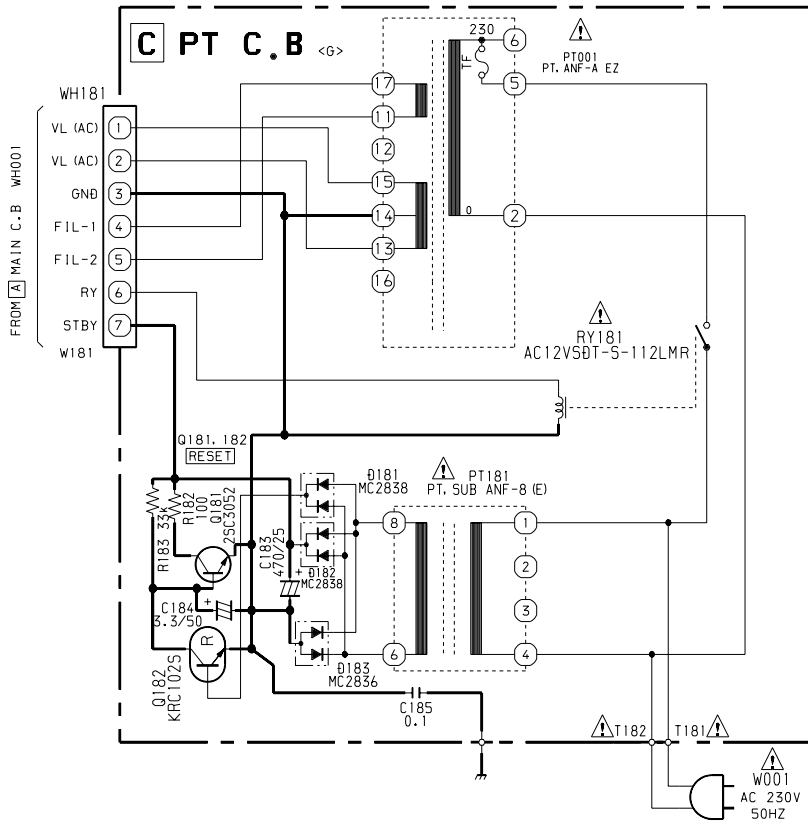

WIRING-7 (DECK)

15	14	13	12	11	10	9	8	7	6	5	4	3	2	1
----	----	----	----	----	----	---	---	---	---	---	---	---	---	---

A
B
C
D
E
F
G
H
I
J
K
L
M
N
O
P
Q
R
S
T
U

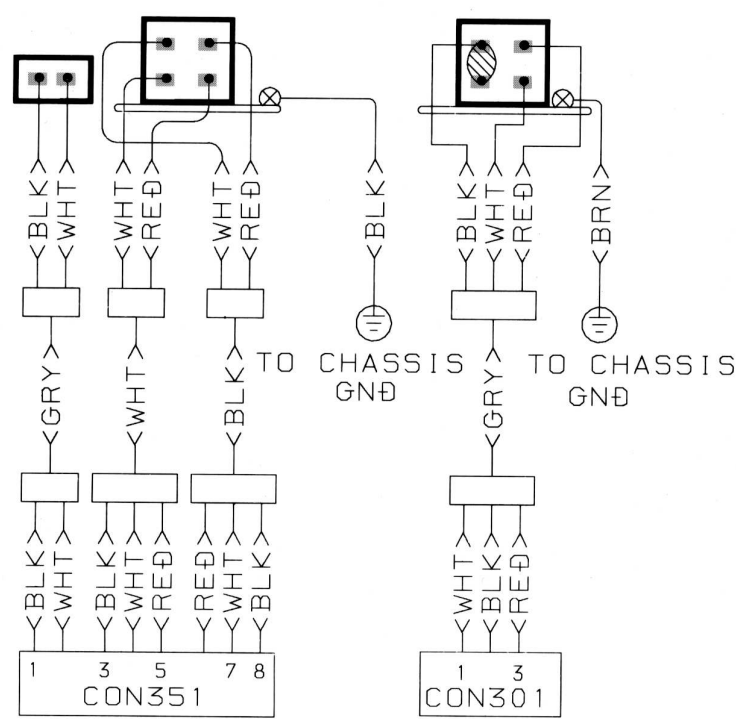
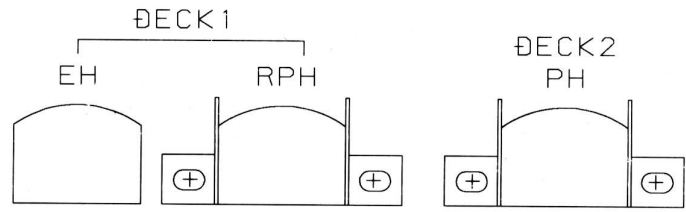

FROM [A] MAIN C.B CN351 FROM [A] MAIN C.B CN301 M1 (DECK MOTOR)

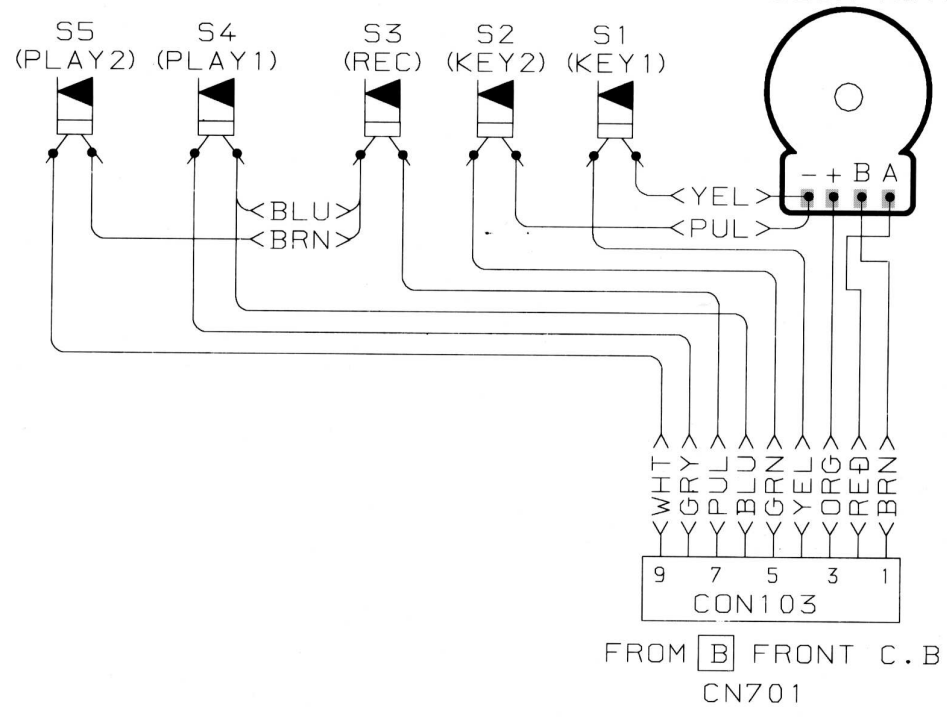

Downloaded from www.Manualslib.com manuals search engine

IC BLOCK DIAGRAM

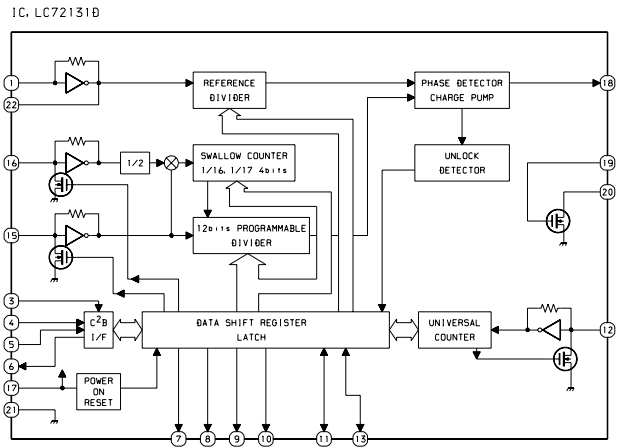
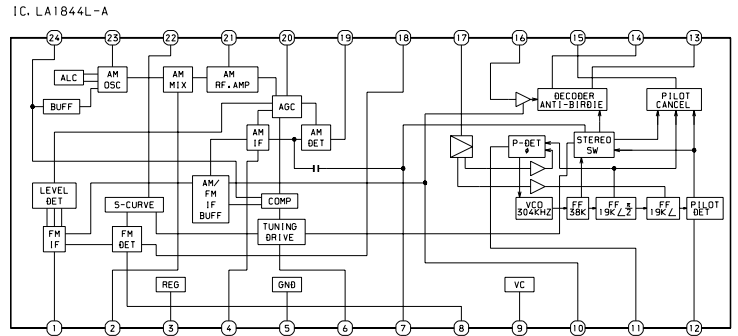
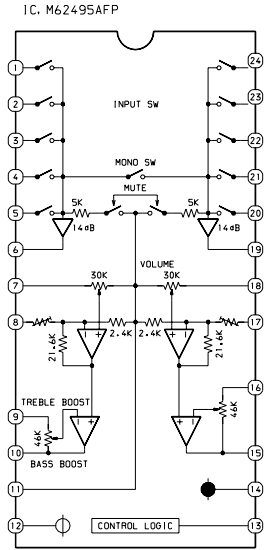

IC DESCRIPTION
IC, M38B57MCH-E236FP

Pin No.	Pin Name	I/O	Description
1	I-SIG	I	RDS signal level A/D input. (Not used)
2	I-HOLD	I	Hold voltage level A/D input.
3	I-SW (CD)	I	CD mecha SW A/D input.
4	I-DISH	I	CD turn-table position check A/D input.
5	I-KEY2	I	KEY2 A/D input.
6	I-KEY1	I	KEY1 A/D input.
7	I-RDS-DATA/ (O-DSP_DATA)	I/O	RDS data input / DSP IC data (V-CD) output. (Not used)
8	O-MOTOR	O	Deck motor supply ON/OFF output.
9	I-RMC	I	System remote control signal input. ("L"=ACTIVE)
10	RESET	I	System reset input. ("L"=RESET)
11	I-STEREO	I	Tuner stereo input. ("L"=STEREO)
12	O-DSC/O-PLL_DATA	O	Function IC control & PLL data output.
13	VSS	-	GND.
14,15	XIN, XOUT	I/O	4.19MHz system CLK input / output.
16	VCC	-	Power supply input.
17	O-PB1	O	Deck 1/2 switch output. ("L"=PLAYBACK DECK 1)
18	O-STBY	O	Standby LED ON/OFF output. ("L"=ON)
19	O-RMT	O	REC mute output. ("H"=MUTE)
20	O-BIAS	O	Record bias ON/OFF output. ("L"=ON)
21	O-TU_ON	O	Tuner supply ON/OFF output. ("H"=ON)
22	O-CD_ON	O	CD supply ON/OFF output. ("H"= ON)
23	O-C.SHIFT	O	MICON clock shift output. ("L"=SHIFT)
24	O-PLL-CLK	O	PLL IC CLK output.
25	I-TM_BASE	I	8 Hz time base input.
26	O-CLOSE	O	CD door close output.
27	O-CD-OPEN	O	CD door open output.
28	VEE	-	Power supply input for FL display.
29	O-STB(DSP)	O	DSP IC strobe output. (Not used)
30	K-SCAN	O	Initial key scan output.
31	O-PLL_CE	O	CD PLL IC chip enable output.
32	O-CD_LED	O	CD flash window LED output.
33~42	G10~G1	O	FL grid output (G10~G1).
43	P22	O	FL segment output (P22). (Not used)
44~58	P21~P7	O	FL segment output (P21~P7).
59	PHONO/P6	I/O	PHONO diode input / FL segment output (P6).
60	CASINO DEMO/P5	I/O	CASINO DEMO diode input (Not used) / FL segment output (P5).
61	NON-ECO/P4	I/O	ECO OFF diode input / FL segment output (P4).
62	I-TU3/P3	I/O	TU 3 diode input (Not used) / FL segment output (P3).
63	I-TU2/P2	I/O	TU 2 diode input (Not used) / FL segment output (P2).
64	I-TU1/P1	I/O	TU 1 diode input (Not used) / FL segment output (P1).

Pin No.	Pin Name	I/O	Description
65	O-DISH_R	O	CD turn-table reverse turn output.
66	O-DISH_F	O	CD turn-table forward turn output.
67	I-SUBQ	I	Sub code-Q data input.
68	O-CD_CE	O	CD DSP chip enable output.
69	I-WRQ	I	CD WRQ input.
70	O-CLK (CD)	O	CD control clock output .
71	O-DATA (CD)	O	CD control data output.
72	I-TUNE/IFC	I	Tuner SD input / IF count input.
73	AVSS	-	GND.
74	VREF	-	Reference voltage.
75	I-DRF	I	CD DRF input.
76	I-RDS_CLK	I	RDS clock input. (Not used)
77	I-LEVEL	I	Connected to GND through a resistor.
78	O-POWER	O	SYSTEM Power ON/OFF output. ("H"=ON)
79	I-RE_VOL	I	Rotary encoder A/D input.
80	I-TP_SW	I	Deck mecha SW A/D input.

ADJUSTMENT <TUNER / DECK>

<TUNER SECTION>

- 1. Clock Frequency Check**
Settings : • Test point : TP2 (CLK)
Method : Set to MW 1602kHz and check that the test point is 2052kHz \pm 0.045kHz.
- 2. MW VT Check**
Settings : • Test point : TP1 (VT)
Method : Set to MW 1602kHz and check that the test point is less than 8.0V.
Then set to 531kHz and check that the test point is more than 0.6V.
- 3. FM VT Check**
Settings : • Test point : TP1 (VT)
Method : Set to FM 87.5MHz, 108.0MHz and check that the test point is more than 0.5V (87.5MHz) and less than 8.0V (108.0MHz).
- 4. MW Tracking Adjustment<G>**
Settings : • Test point : TP8(Lch), TP9(Rch)
• Adjustment location :
L951 (1/3) 1000kHz
Method : Set to AM(MW) 999kHz and adjust L951 (1/3) to MAX.
- 5. MW VT Adjustment<HT>**
Settings : • Test point : TP1 (VT)
• Adjustment location : L953
Method : Set to MW 1602kHz and adjust L953 so that the test point becomes 8.0V \pm 0.05V. Then set to MW 531kHz and check that the test point is more than 0.3V.
- 6. MW Tracking Adjustment<HT>**
Settings : • Test point : TP8(Lch), TP9(Rch)
• Adjustment location :
L952 603kHz
TC941 1404kHz
Method : Set up TC941 to center before adjustment.
The level at 603kHz is adjust to max. by L952.
Then the level at 1404kHz is adjust to max. by TC941.
- 7. FM Tracking Check**
Settings : • Test point : TP8(Lch), TP9(Rch)
Method : Set to FM 98.0MHz and check that the test point is less than 9dB μ V(HT), less than 13dB μ V(G).
- 8. MW IF Adjustment**
Settings : • Test point : TP8(Lch), TP9(Rch)
• Adjustment location :
L802 450kHz

- 9. SW VT Adjustment<HT>**
Settings : • Test point : TP1(VT)
• Adjustment location : L942
Method : Set to SW 17.9MHz and adjust L942 so that the test point becomes 8.0V \pm 0.05V. Then set to SW 5.73MHz and check that the test point is more than 0.3V.
- 10. SW Tracking Adjustment<HT>**
Settings : • Test point : TP8(Lch), TP9(Rch)
• Adjustment location :
L941 5.9MHz
TC943 17.9MHz
Method : Set up TC943 to center before adjustment.
The level at 5.9MHz is adjust to max. by L941.
Then the level at 17.9MHz is adjust to max. by TC943.
- 11. LW VT Adjustment<G>**
Settings : • Test point : TP1 (VT)
• Adjustment location : L942
Method : Set to LW 144kHz and adjust L942 so that the test point becomes 1.3V \pm 0.05V.
Then set to LW 290kHz and check that the test point is less than 8.0V.
- 12. LW Tracking Adjustment<G>**
Settings : • Test point : TP8 (Lch), TP9 (Rch)
• Adjustment location :
L941 144kHz
TC942 290kHz
Method : Set up TC942 to center before adjustment. The level at 144kHz is adjusted to MAX by L941. Then the level at 290kHz is adjusted to MAX by TC942.
- 13. DC Balance / Mono Distortion Adjustment**
Settings : • Test point : TP3, TP4 (DC Balance)
• Adjustment location : L801
• Input level : 60dB μ V
Method : Set to FM 98.0MHz and adjust L801 so that the voltage between TP3 and TP4 becomes 0V \pm 300 mV with minimum distortion.

<DECK SECTION>

- 14. Tape Speed Adjustment (DECK 1)**
Settings : • Test tape : TTA-100
• Test point : TP8(Lch), TP9(Rch)
• Adjustment location : SFR701
Method : Play back the test tape and adjust SFR701 so that the frequency counter reads 3000Hz \pm 5Hz.
- 15. Head Azimuth Adjustment (DECK 1, DECK 2)**
Settings : • Test tape : TTA-330
• Test point : TP8(Lch), TP9(Rch)
• Adjustment location : Head azimuth adjustment screw
Method : Play back (FWD) the 8kHz signal of the test tape and adjust screw so that the output becomes maximum.
Next, perform on REV PLAY mode.
- 16. PB Frequency Response Check (DECK 1, DECK 2)**
Settings : • Test tape : TTA-330
• Test point : TP8(Lch), TP9(Rch)
Method : Play back the 315Hz and 8kHz signals of the test tape and check that the output ratio of the 8kHz signal with respect to that of the 315Hz signal is within 4dB.
- 17. PB Sensitivity Check (DECK 1, DECK 2)**
Settings : • Test tape : TTA-200
• Test point : TP8(Lch), TP9(Rch)
Method : Play back the test tape and check that the output level of the test point is 110mV \pm 3.5dB.
- 18. REC/PB Frequency Response Check (DECK 1)**
Settings : • Test tape : TTA-602
• Test point : TP8(Lch), TP9(Rch)
• Input signal : 1kHz / 8kHz (LINE IN)
Method : Apply a 1kHz signal and REC mode. Then adjust OSC attenuator so that the output level at the test points becomes -20VU. Record and play back the 1kHz and 8kHz signals and check that the output of the 8kHz signals is 0dB \pm 5dB with respect to that of the 1kHz signal.
- 19. REC/PB Sensitivity Check (DECK 1)**
Settings : • Test tape : TTA-602
• Test point : TP8(Lch), TP9(Rch)
• Input signal : 1kHz (LINE IN)
Method : Apply a 1kHz signal and REC mode. Then adjust OSC attenuator so that the output level at TP8, TP9 becomes 0VU. Record and play back the 1kHz signals and check that the output is -2dB \pm 3.5dB.

< FRONT SECTION >

- 20. u-CON OSC Adjustment**
Settings : • Test point : TP5(K-SCAN)
• Adjustment location : L101
Method : Insert AC plug with pressing of TUNER function key and POWER key. Adjust L101 so that the frequency across the test point is 58.350Hz \pm 0.02Hz.

MECHANICAL EXPLODED VIEW 1 / 1

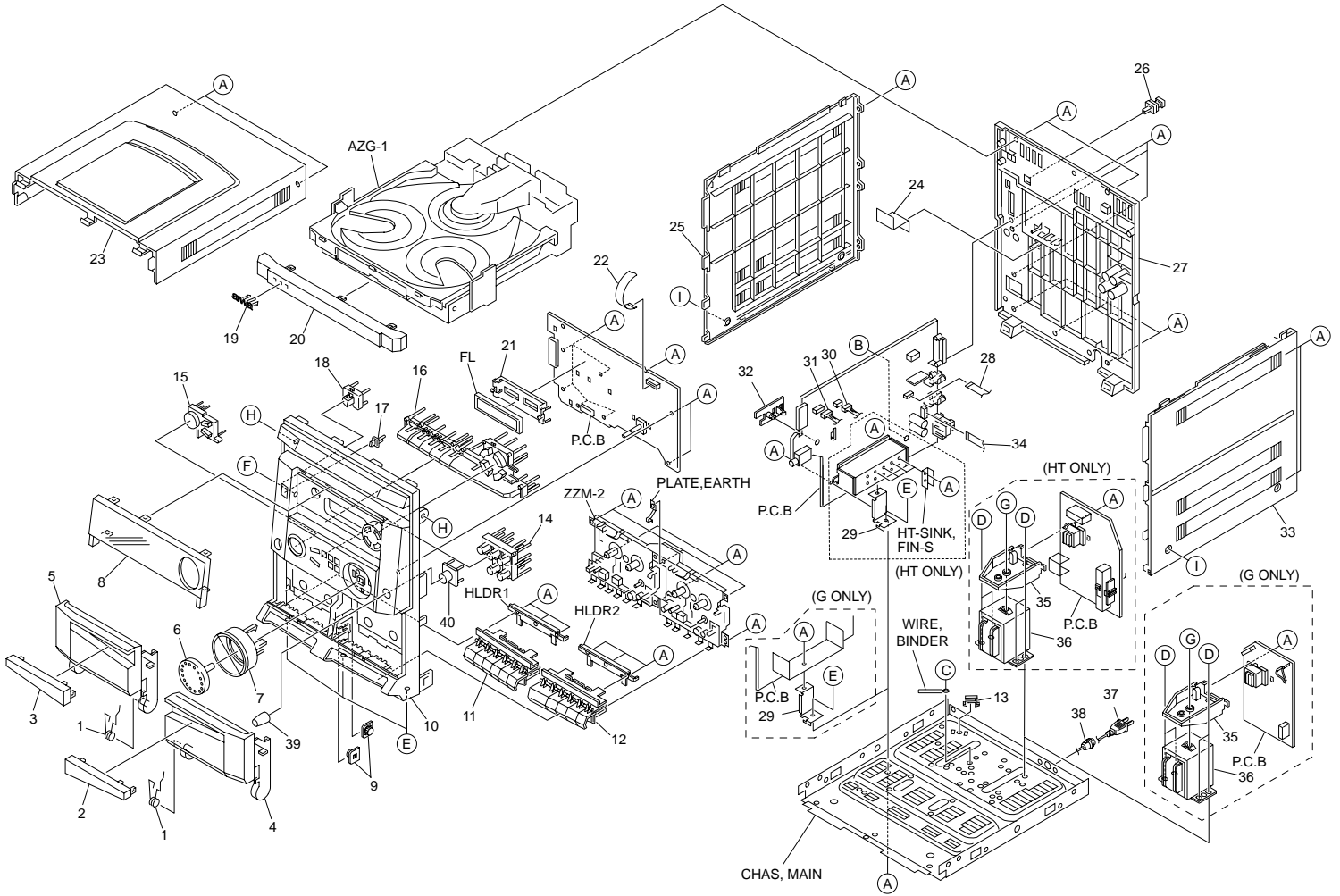

MECHANICAL PARTS LIST 1 / 1

REF. NO.	PART NO.	KANRI NO.	DESCRIPTION	REF. NO.	PART NO.	KANRI NO.	DESCRIPTION
1	82-NF7-218-010		SPR-T, CASS	33	8A-NFA-067-010		PANEL, RIGHT V-2 PL<G>
2	8A-NFZ-007-110		WINDOW, CASS 2	34	85-NF5-628-010		F-CABLE 7P-2.5<G>
3	8A-NFZ-006-110		WINDOW, CASS 1	35	8A-NF9-211-010		HLDR, PWB PT HI
4	8A-NFZ-004-110		BOX, CASS 2	△	36	8A-NFA-608-010	PT, ANF-A EZ<G>
5	8A-NFZ-003-110		BOX, CASS 1	△	36	8A-NFA-606-010	PT, ANF-A HR<HT>
6	8A-NFZ-011-010		KNOB, RTRY VOL	△	37	87-A80-157-010	AC CORD ASSY, E BLK CC<HT>
7	8A-NFZ-012-010		RING, VOL	△	37	87-A80-146-010	AC CORD ASSY, G<G>
8	8A-NFZ-051-010		WINDOW, DISP H		38	87-085-185-010	BUSHING, AC CORD (E)
9	86-NFZ-231-010		DMPR, 70		39	8A-NFZ-020-010	KNOB, RTRY MIC BL<HT>
10	8A-NFZ-041-210		CABI, FR H<HT>	40	8A-NFZ-047-010	PLATE, MIC BL<HT>	
10	8A-NFZ-001-210		CABI, FR U<G>	A	87-067-703-010	TAPPING SCREW, BVT2+3-10	
11	8A-NFZ-016-110		KEY, CASS 1	B	87-NF4-224-010	S-SCREW, IT3B+3-8 CU	
12	8A-NFZ-017-110		KEY, CASS 2P	C	87-078-191-010	S-SCREW, IT+4-10<HT>	
13	87-NF4-221-010		HLDR, CABLE<HT>	D	87-078-200-010	S-SCREW, ITC+4-8 R<G>	
14	8A-NFZ-010-010		KEY, OPE	E	87-067-688-010	BVTT+3-6	
15	8A-NFZ-013-210		KEY, CD	F	87-723-096-410	QT2+3-10W/O SLOT BL	
16	8A-NFZ-009-010		KEY, FUN	G	87-067-641-010	UTT2+3-8 (W/O SLOT) BL	
17	8A-NFA-018-010		REFLECTOR, ECO	H	87-721-097-410	QT2+3-12 GLD	
18	8A-NFZ-008-010		KEY, POWER				
19	87-CE3-023-010		BADGE, AIWA 30N SILV				
20	8A-NFZ-002-010		PANEL, TRAY H				
21	8A-NFA-208-010		GUIDE, FL 100-25 ANFA				
22	88-913-221-110		FF-CABLE, 13P 1.25 220MM				
23	8A-NFA-062-010		PANEL, TOP V-2				
24	8A-NFA-215-010		PLATE, PL HR<HT >				
25	8A-NFA-063-010		PANEL, LEFT V-2				
26	84-ZG1-245-210		CAP, OPTICAL				
27	8A-NFZ-040-010		CABI, REAR G W/O SPEC<G>				
27	8A-NFA-040-010		CABI, REAR HR W/O SPEC<HT>				
28	88-906-251-110		FF-CABLE, 6P 1.25				
29	88-NF9-213-010		HLDR, PWB MAIN				
30	8A-NFA-633-010		CONN ASSY, 3P (PH)				
31	8A-NFA-634-010		CONN ASSY, 8P RPB				
32	8A-NFA-214-010		HLDR, PWB M ANFA				
33	8A-NFA-065-010		PANEL, RIGHT V-2<HT>				

COLOR NAME TABLE

Basic color symbol	Color	Basic color symbol	Color	Basic color symbol	Color
B	Black	C	Cream	D	Orange
G	Green	H	Gray	L	Blue
LT	Transparent Blue	N	Gold	P	Pink
R	Red	S	Silver	ST	Titan Silver
T	Brown	V	Violet	W	White
WT	Transparent White	Y	Yellow	YT	Transparent Yellow
LM	Metallic Blue	LL	Light Blue	GT	Transparent Green
LD	Dark Blue	DT	Transparent Orange	GM	Metallic Green
YM	Metallic Yellow	DM	Metallic Orange	PT	Transparent Pink

TAPE MECHANISM EXPLODED VIEW 1 / 1

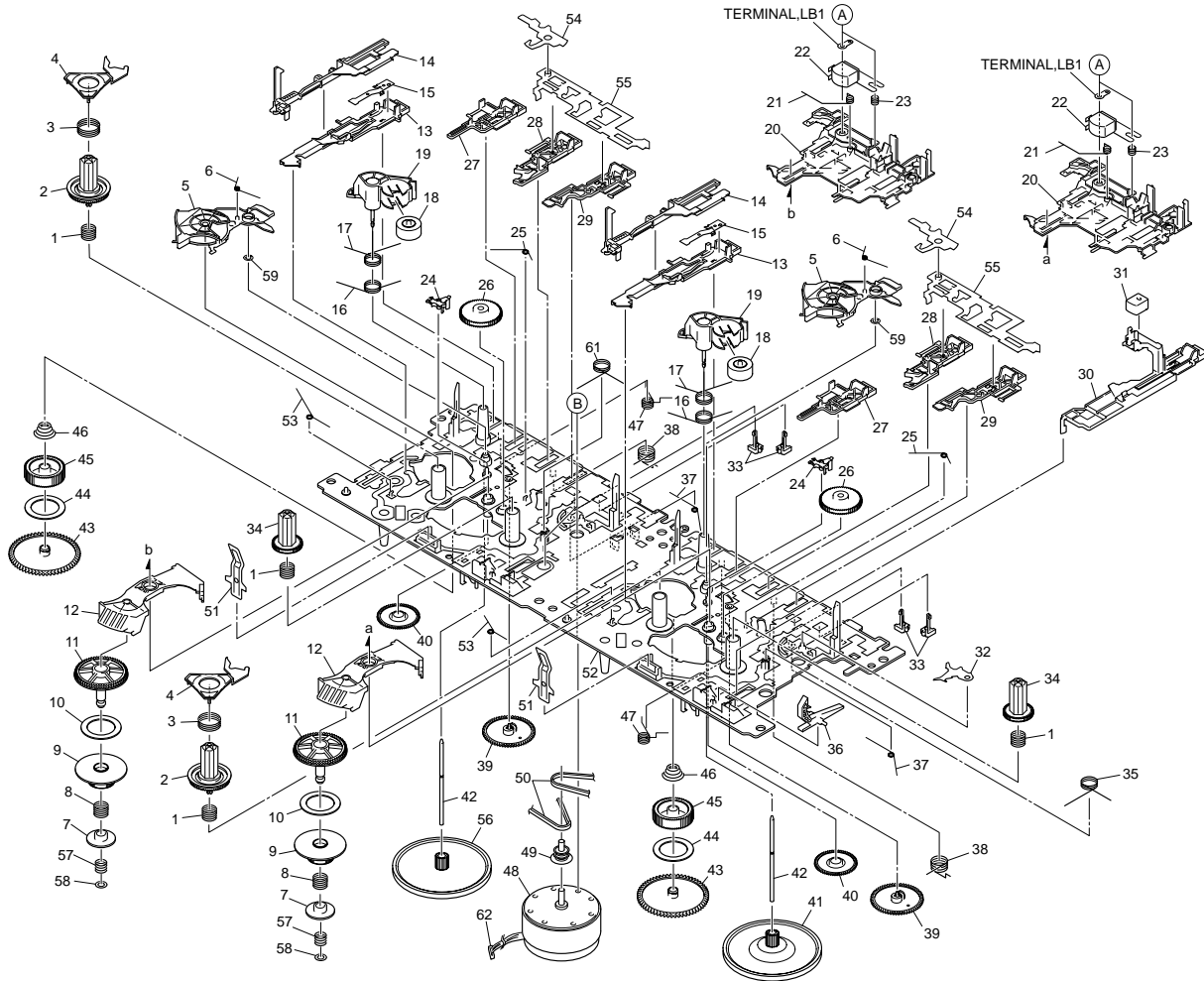

TAPE MECHANISM PARTS LIST 1 / 1

REF. NO.	PART NO.	KANRI NO.	DESCRIPTION	REF. NO.	PART NO.	KANRI NO.	DESCRIPTION
1	8Z-ZM1-254-210		SPR-C, REEL R	41	8Z-ZM1-234-010		FLY-WHL, ZZM-1
2	8Z-ZM1-225-110		GEAR, REEL R	42	8Z-ZM1-267-010		SHAFT, CAPSTAN 2
3	8Z-ZM1-253-110		SPR-C, AUTO SENSOR	43	8Z-ZM1-228-010		GEAR, SLIP T-UP B
4	8Z-ZM1-217-110		LEVER, AUTO SENSOR	44	8Z-ZM1-265-010		FELT, T-UP
5	8Z-ZM1-212-110		LEVER, T-UP	45	8Z-ZM1-227-010		GEAR, SLIP T-UP A
6	8Z-ZM1-245-010		SPR-T, AUTO	46	8Z-ZM1-251-110		SPR-C, T-UP SLIP
7	8Z-ZM1-236-010		CLR, SLIP FF/REW	47	8Z-ZM1-243-210		SPR-T, STOP/PAUSE
8	8Z-ZM1-252-010		SPR-C, FF/REW	48	87-A91-532-010		MOT, MS15U2LW1A
9	8Z-ZM1-230-010		GEAR, SLIP FF/REW A	49	8Z-ZM1-235-010		PULLEY, MOT
10	8Z-ZM1-269-010		FELT, FF/REW 2	50	8Z-ZM2-216-010		BELT, MAIN M
11	8Z-ZM1-238-110		GEAR, SLIP FF/REW B 2	51	8Z-ZM1-260-010		SPR-P, CASSETTE
12	8Z-ZM1-237-010		LEVER, FF/REW 2	52	8Z-ZM2-201-010		CHAS ASSY, ZZM-2
13	8Z-ZM1-209-210		LEVER, PAUSE	53	8Z-ZM1-255-110		SPR-T, E-LOCK
14	8Z-ZM1-218-110		LEVER, E-LOCK H	54	8Z-ZM2-219-010		LEVER, E-OPEN ZZM-2
15	8Z-ZM1-256-010		SPR-P, PAUSE	55	8Z-ZM1-214-110		LEVER, LOCK
16	8Z-ZM1-244-010		SPR-T, T-UP	56	8Z-ZM2-211-010		FLY-WHL, ZZM-2
17	8Z-ZM1-247-210		SPR-T, PINCH	57	8Z-ZM1-257-110		SPR-C, F/R
18	8Z-ZM1-261-110		ROLLER ASSY, PINCH	58	8Z-ZM1-275-010		W-L, 1.47-4-0.25
19	8Z-ZM1-221-010		LEVER, PINCH	59	80-ZM6-243-010		SH 1.75-3.6-0.5 SLT
20	8Z-ZM1-205-210		LEVER, PLAY	60	87-A91-494-010		SW, LEAF MSW17820
21	8Z-ZM1-248-110		SPR-T, BRG	61	8Z-ZM1-241-010		SPR-T, PLAY
22	87-A90-403-110		HEAD, RPH MS15R	62	8Z-ZM2-601-010		CONN ASSY, 9P ZZM-2
23	84-ZM2-227-310		SPR-C, AZIMUTH	A	84-ZM2-242-010		S-SCREW, AZ1-2-6.4
24	8Z-ZM1-216-010		LEVER, AUTO	B	8Z-ZM2-220-110		V+2.6 ZZM-2
25	8Z-ZM1-246-010		SPR-T, AUTO 2				
26	8Z-ZM2-214-010		GEAR, IDL REW ZZM-2				
27	8Z-ZM2-212-010		LEVER, STOP ZZM-2				
28	8Z-ZM1-207-010		LEVER, FF				
29	8Z-ZM1-206-010		LEVER, REW				
30	8Z-ZM1-210-010		LEVER, REC				
31	87-A90-404-010		HEAD, EH LE15B				
32	8Z-ZM2-218-010		LEVER, REC LOCK ZZM-2				
33	87-A91-492-010		SW, LEAF MSW18560				
34	8Z-ZM1-226-010		GEAR, REEL L				
35	8Z-ZM1-241-010		SPR-T, PLAY				
36	8Z-ZM1-220-110		LEVER, REC SENSOR				
37	8Z-ZM1-249-010		SPR-T, FR				
38	8Z-ZM1-242-110		SPR-T, FF/REW				
39	8Z-ZM1-229-010		GEAR, CAM				
40	8Z-ZM1-232-010		GEAR, IDL FF/REW				

SPEAKER DISASSEMBLY INSTRUCTIONS

Type.1

Insert a flat-bladed screwdriver into the position indicated by the arrows and remove the panel. Remove the screws of each speaker unit and then remove the speaker units.

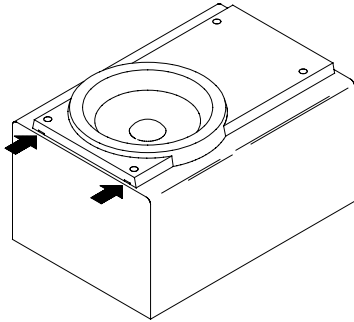

Type.2

Remove the grill frame and four pieces of rubber caps by pulling out with a flat-bladed screwdriver. Remove the screws from hole where installed rubber caps. Insert a flat-bladed screwdriver into the position indicated by the arrows and remove the panel. Remove the screws of each speaker unit and then remove the speaker units.

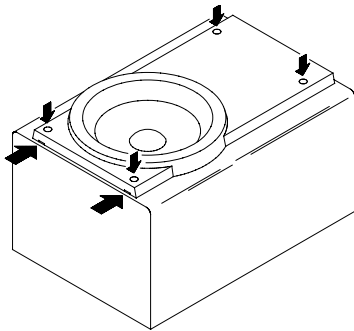

Type.3

Insert a flat-bladed screwdriver into the position indicated by the arrows and remove the panel. Turn the speaker unit to counter-clockwise direction while inserting a flat-bladed screwdriver into one of the hollows around speaker unit, and then remove the speaker unit. After replacing the speaker unit, install it turning to clockwise direction until "click" sound comes out.

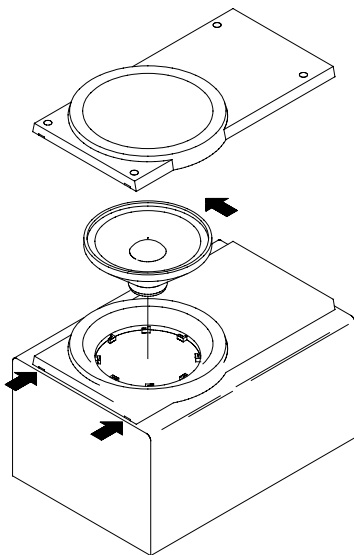

Type.4

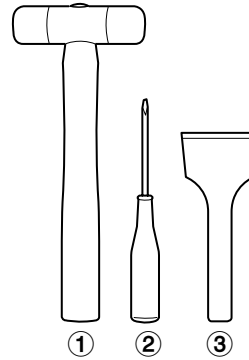

TOOLS

- ① Plastic head hammer
- ② (⊖) flat head screwdriver
- ③ Cut chisel

How to Remove the PANEL, FR

1. Insert the (⊖) flat head screwdriver tip into the gap between the PANEL, FR and the PANEL, SPKR. Tap the head of the (⊖) flat head screwdriver with the plastic hammer head, and create the clearance as shown in Fig-1.
2. Insert the cut chisel in the clearance, and tap the head of the cut chisel with plastic hammer as shown in Fig-2, to remove the PANEL, FR.
3. Place the speaker horizontally. Tap head of the cut chisel with plastic hammer as shown in Fig-3, and remove the PANEL, FR completely.

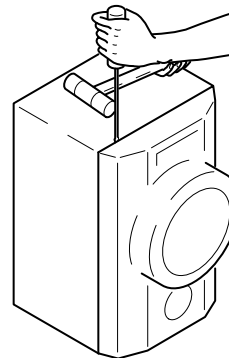

Fig-1

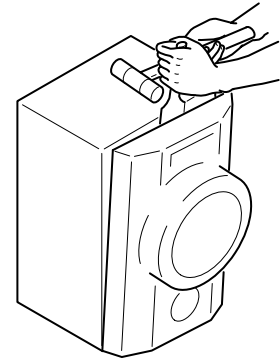

Fig-2

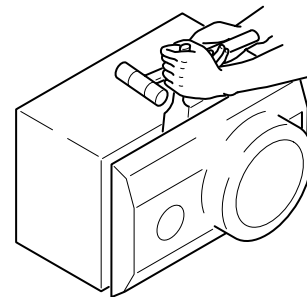

Fig-3

How to Attach the PANEL, FR

Attach the PANEL, FR to the PANEL, SPKR. Tap the four corners of the PANEL, FR with the plastic hammer to fit the PANEL, FR into the PANEL, SPKR completely.

SPEAKER PARTS LIST SX-NBL11(Y1SL,YSC9,YSC,YSL)

REF.NO.	PART NO.	KANRI NO.	DESCRIPTION
1	8A-NSB-001-010		PANEL,FR
2	8A-NSB-003-010		GRILLE,FRAME ASSY
3	8Z-NSL-603-010		SPKR, W 120<YSC9>
3	8A-NSL-606-010		SPKR, W120<YSC,YSL,Y1SL>
4	87-NS7-611-010		CORD,SPKR

ACCESSORIES / PACKAGE LIST

REF.NO.	PART NO.	KANRI NO.	DESCRIPTION
1	8A-NFZ-901-010		IB,H(ECA)M-BL14<HT>
1	8A-NFZ-904-010		IB,G(E)M-BL14<G>
2	8Z-NF9-701-210		RC UNIT,ZAS02
3	87-A90-118-010		ANT,WIRE FM (Z)<G>
3	87-A90-119-010		ANT,WIRE SW (5M)<HT>
4	87-043-115-010		ANT,FEEDER FM<HT>
5	87-006-225-010		AM LOOP ANT NC2<G>
5	87-006-226-010		AM LOOP ANT C0<HT>
△ 6	87-A91-017-010		PLUG,CONVERSION JT-0476<HT>



アイワ株式会社 〒110-8710 東京都台東区池之端1-2-11 ☎03(3827)3111 (代表)
AIWA CO.,LTD. 2-11, IKENOHATA 1-CHOME, TAITO-KU, TOKYO 110, JAPAN TEL:03 (3827) 3111

9630472 0251431

Printed in Singapore