

Self Diagnosis
Supported model

SERVICE MANUAL

AE-6B CHASSIS

MODEL	COMMANDER	DEST	CHASSIS NO.	MODEL	COMMANDER	DEST	CHASSIS NO.
KV-29XL70E	RM-944	ESP	SCC-Q81X-A	KV-29XL71E	RM-934	ESP	SCC-Q81W-A
KV-29XL70K	RM-944	OIRT	SCC-Q82M-A	KV-29XL71K	RM-934	OIRT	SCC-Q82N-A

FD Trinitron



RM-934



KV-29XL70/71



RM-944

TRINITRON[®] COLOR TV
SONY[®]

TABLE OF CONTENTS

Section	Title	Page	Section	Title	Page
	Caution	3	5. DIAGRAMS		
	Specifications	4	5-1.	Block Diagrams (1)	24
	Connectors	5		Block Diagrams (2)	25
	Self Diagnostic Software	6		Block Diagrams (3)	26
1. GENERAL			5-2.	Circuit Board Location	26
	Switching On the TV and Automatically Tuning	7	5-3.	Schematic Diagrams and Printed Wiring Boards	26
	Introducing and Using the Menu System	8		* A Board Schematic	27
	Menu Guide	8		* A Board PWB	34
	Teletext	10		* F1 Board Schematic	37
	Fastext	10		* F1 Board PWB	38
	Connecting Additional Equipment	11		* H6 Board Schematic	37
	Specifications	12		* H6 Board PWB	38
	Troubleshooting	12		* VM Board Schematic	37
				* VM Board PWB	36
2. DISASSEMBLY				* G Board Schematic	39
	2-1. Rear Cover Removal	13		* G Board PWB	38
	2-2. Speaker Connector Disconnection.....	13		* D Board Schematic	40
	2-3. Chassis Removal and Refitting	13		* D Board PWB	41
	2-4. Service Position	14		* C Board Schematic	42
	2-5. G Board Removal	14		* C Board PWB	43
	2-6. Service Connector for M Board.....	14		* M Board Schematic	44
	2-7. Wire Dressing	14	5-4.	Semiconductors	45
	2-8. Picture Tube Removal	15	5-5.	IC Blocks	48
	Bottom Plates	16			
3. SET-UP ADJUSTMENTS			6. EXPLODED VIEWS		
	3-1. Beam Landing	17	6-1.	Chassis	50
	3-2. Convergence	18	6-2.	Picture Tube	51
	3-3. Focus Adjustment	20	7. ELECTRICAL PARTS LIST		52
	3-4. Screen (G2), White Balance	20			
4. CIRCUIT ADJUSTMENTS					
	4-1. Electrical Adjustments	21			
	4-2. Test Mode 2	23			

CAUTION

SHORT CIRCUIT THE ANODE OF THE PICTURE TUBE AND THE ANODE CAP TO THE METAL CHASSIS, CRT SHIELD, OR THE CARBON PAINTED ON THE CRT, AFTER REMOVAL OF THE ANODE CAP.

WARNING !!

AN ISOLATION TRANSFORMER SHOULD BE USED DURING ANY SERVICE WORK TO AVOID POSSIBLE SHOCK HAZARD DUE TO LIVE CHASSIS, THE CHASSIS OF THIS RECEIVER IS DIRECTLY CONNECTED TO THE POWER LINE.

SAFETY-RELATED COMPONENT WARNING !!

COMPONENTS IDENTIFIED BY SHADING AND MARKED Δ ON THE SCHEMATIC DIAGRAMS, EXPLODED VIEWS AND IN THE PARTS LIST ARE CRITICAL FOR SAFE OPERATION. REPLACE THESE COMPONENTS WITH SONY PARTS WHOSE PART NUMBERS APPEAR AS SHOWN IN THIS MANUAL OR IN SUPPLEMENTS PUBLISHED BY SONY.

ATTENTION

APRES AVOIR DECONNECTE LE CAP DE L'ANODE, COURT-CIRCUITER L'ANODE DU TUBE CATHODIQUE ET CELUI DE L'ANODE DU CAP AU CHASSIS METALLIQUE DE L'APPAREIL, OU AU COUCHE DE CARBONE PEINTE SUR LE TUBE CATHODIQUE OU AU BLINDAGE DU TUBE CATHODIQUE.

ATTENTION !!

AFIN D'EVITER TOUT RISQUE D'ELECTROCUTION PROVENANT D'UN CHASSIS SOUS TENTION, UN TRANSFORMATEUR D'ISOLEMENT DOIT ETRE UTILISE LORS DE TOUT DEPANNAGE LE CHASSIS DE CE RECEPTEUR EST DIRECTMENT RACCORDE A L'ALIMENTATION SECTEUR.

ATTENTION AUX COMPOSANTS RELATIFS A LA SECURITE!!

LES COMPOSANTS IDENTIFIES PAR UNE TRAME ET PAR UNE MARQUE Δ SUR LES SCHEMAS DE PRINCIPE, LES VUES EXPLOSEES ET LES LISTES DE PIECES SONT D'UNE IMPORTANCE CRITIQUE POUR LA SECURITE DU FONCTIONNEMENT, NE LES REMPLACER QUE PAR DES COMPOSANTS SONY DONT LE NUMERO DE PIECE EST INDIQUE DANS LE PRESENT MANUEL OU DANS DES SUPPLEMENTS PUBLIES PAR SONY.

CAUTION

Lead Free Soldered Boards

The circuit boards listed below [Table 1] used in these models may have been processed using Lead Free Solder. The boards are identified by the LF logo located close to the board designation e.g. F1, H1 etc [see examples]. The servicing of these boards requires special precautions to be taken as outlined below.



Table 1

Board	Function
A	Video & Audio Processors, Audio Output, Vertical Deflection
C	R,G,B Out
F1	Power Switch/Fuse/SIRCS/Standby LED
H6	Front AV Input/Headphone and Control Switches
VM	Velocity Modulation

example 1

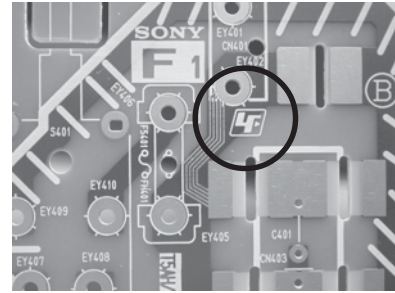

example 2

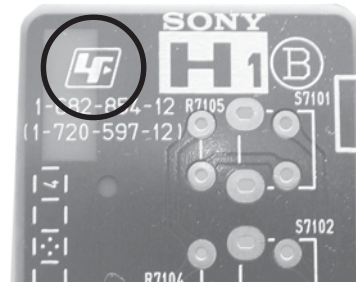

It is strongly recommended to use Lead Free Solder material in order to guarantee optimal quality of new solder joints. Lead Free Solder is available under the following part numbers :

Partnumber	Diameter	Remarks
7-640-005-19	0.3mm	0.25Kg
7-640-005-20	0.4mm	0.50Kg
7-640-005-21	0.5mm	0.50Kg
7-640-005-22	0.6mm	0.25Kg
7-640-005-23	0.8mm	1.00Kg
7-640-005-24	1.0mm	1.00Kg
7-640-005-25	1.2mm	1.00Kg
7-640-005-26	1.6mm	1.00Kg

Due to the higher melting point of Lead Free Solder the soldering iron tip temperature needs to be set to 370 degrees centigrade. This requires soldering equipment capable of accurate temperature control coupled with a good heat recovery characteristics.

For more information on the use of Lead Free Solder, please refer to <http://www.sony-training.com>

ITEM MODEL	Television System	Stereo System	Channel Coverage	Color System
E	B/G/H, D/K	GERMAN/NICAM Stereo	VHF : E2-E12, R1-R12, S01-S03 UHF : E21-E69, R21-R69 CABLE TV : S01-S20 HYPER : S21-S41	PAL, SECAM NTSC4.43, NTSC3.58 (VIDEO IN)
K	B/G/H, D/K	GERMAN/NICAM Stereo	VHF : E2-E12, R1-R12, S01-S03 UHF : E21-E69, R21-R69 CABLE TV : S01-S20 HYPER : S21-S41	PAL, SECAM NTSC4.43, NTSC3.58 (VIDEO IN)

Picture Tube	Flat Display FD Trinitron Approx 73 cm (29 inches)	Sound output	
		Right and Left speaker	2x20W (Music Power) 2x10W (RMS)
		Sub Woofer	1x30W (Music Power) 1x15W (RMS)
Input/Output Terminals [REAR]		General Specifications	
1: 21-pin Euro connector (CENELEC standard)	Inputs for Audio and Video signals. Inputs for RGB. Outputs of TV Video and Audio signals.	Power Requirements	220 - 240V
		Power Consumption	130W
2: 21-pin Euro connector	Inputs for Audio and Video signals. Inputs for RGB. Outputs of TV Video and Audio signals. (Monitor Out)	Dimensions	Approx 771 x 585 x 506mm
		Weight	Approx 48.5kg
3: 21-pin Euro connector (SMARTLINK)	Inputs for Audio and Video signals. Inputs for S Video. Outputs of TV Video and Audio signals. (selectable)	Supplied Accessories	RM-934 Remote Commander (1) (KV-29XL71) RM-944 Remote Commander (1) (KV-29XL70) IEC designated R6 battery (2)
Phono Jacks	Output Connectors variable for Audio Signals	Other Features	100 Hz picture, Teletext, Smartlink, TV system autodetection, PIP, Dolby Virtual, BBE, Sleep Timer
Input/Output Terminals [FRONT]		Remote Control System : Infrared Control	
Headphone jack	stereo mini jack	Power requirements	3V dc 2 batteries IEC designation R6 (size AA)
Audio inputs	phono jacks		
Video inputs	phono jacks		
S Video input	4 pin DIN		
Design and specifications are subject to change without notice.			

Model Name Item	KV-29XL70E	KV-29XL70K	KV-29XL71E	KV-29XL71K
Pal Comb	OFF	OFF	OFF	OFF
PIP	ON	ON	ON	ON
RGB Priority	ON	ON	ON	ON
Woofer Box	ON	ON	ON	ON
Scart 1	ON	ON	ON	ON
Scart 2	ON	ON	ON	ON
Scart 3	ON	ON	ON	ON
Front in (4)	ON	ON	ON	ON
Projector	OFF	OFF	OFF	OFF
Norm B/G	ON	ON	ON	ON
Norm I	OFF	OFF	OFF	OFF
Norm D/K	ON	ON	ON	ON
Norm AUS	OFF	OFF	OFF	OFF
Norm L	OFF	OFF	OFF	OFF
Norm SAT	OFF	OFF	OFF	OFF
Norm M	OFF	OFF	OFF	OFF
Teletext	ON	ON	ON	ON
Nicam Stereo	ON	ON	ON	ON

21 pin connector

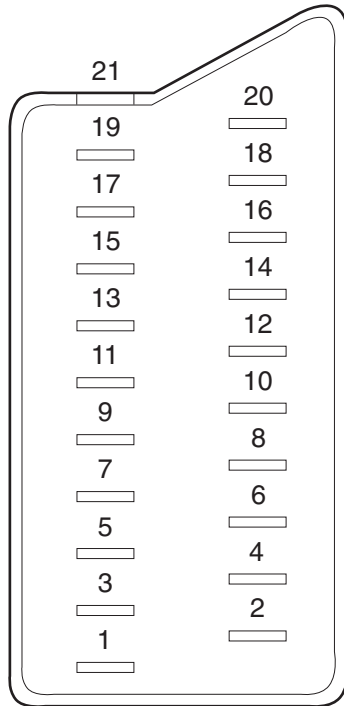

Pin No	1	2	3	Signal	Signal level
1	○	○	○	Audio output B (right)	Standard level : 0.5V rms Output impedance : Less than 1kohm*
2	○	○	○	Audio input B (right)	Standard level : 0.5V rms Output impedance : More than 10kohm*
3	○	○	○	Audio output A (left)	Standard level : 0.5V rms Output impedance : Less than 1kohm*
4	○	○	○	Ground (audio)	
5	○	○	○	Ground (blue)	
6	○	○	○	Audio input A (left)	Standard level : 0.5V rms Output impedance : More than 10kohm*
7	○	●	●	Blue input	0.7 +/- 3dB, 75 ohms positive
8	○	○	○	Function select (AV control)	High state (9.5-12V) : Part mode Low state (0-2V) : TV mode Input impedance : More than 10K ohms Input capacitance : Less than 2nF
9	○	○	○	Ground (green)	
10	○	○	○	Open	
11	○	●	●	Green	Green signal : 0.7 +/- 3dB, 75 ohms, positive
12	○	○	○	Open	
13	○	○	○	Ground (red)	
14	○	○	○	Ground (blanking)	
15	○	-	-	Red input	0.7 +/- 3dB, 75 ohms, positive
	-	○	○	(S signal Chroma input)	0.3 +/- 3dB, 75 ohms, positive
16	○	●	●	Blanking input (Y's signal)	High state (1-3V) Low state (0-0.4V) Input impedance : 75 ohms
17	○	○	○	Ground (video output)	
18	○	○	○	Ground (video input)	
19	○	○	○	Video output	1V +/- 3dB, 75ohms, positive sync 0.3V (-3+10dB)
20	○	-	-	Video input	1V +/- 3dB, 75ohms, positive sync 0.3V (-3+10dB)
	-	○	○	Video input Y (S signal)	1V +/- 3dB, 75ohms, positive sync 0.3V (-3+10dB)
21	○	○	○	Common ground (plug, shield)	

○ Connected ● Not Connected (open) * at 20Hz - 20kHz

Rear Connection Panel



Front Connection Panel



S-Video socket

S Video socket pin configuration		
Pin No	Signal	Signal Level
1	Ground	-
2	Ground	-
3	Y (S signal) input	1V +/- 3dB 75ohm, positive Sync. 0.3V -3 +10dB
4	C (S signal) input	0.3V +/- 3dB 75ohm, positive Sync.

AE-6B SELF DIAGNOSTIC SOFTWARE

The identification of errors within the AE-6B chassis is triggered in one of two ways :- 1: Busy or 2: Device failure to respond to IIC. In the event of one of these situations arising the software will first try to release the bus if busy (Failure to do so will report with a continuous flashing LED) and then communicate with each device in turn to establish if a device is faulty. If a device is found to be faulty the relevant device number will be displayed through the LED (Series of flashes which must be counted) See table 1, non fatal errors are reported using this method.

Each time the software detects an error it is stored within the NVM. See Table 2.

Table 1

Error Message	LED Code
No error	00
Reserved	01
OCP (Over Current Protection)	02
Over Voltage Protection	03
No Vertical Sync	04
IKR Error at power on	05
IIC bus clock and/or data lines low at power on	06
NVM no IIC bus acknowledge at power on	07
Horizontal Protection	08
Tuner no acknowledge at power on	09
Sound Processor Error	10
Reserved	11
Scanrate Error	12
DAC Error	13
Backend Error	14
Dynamic Convergence Error	15
PIP Error	16

How to enter into Table 2

1. Turn on the main power switch and enter into the stand-by mode.
2. Press the following sequence of buttons on the Remote Commander.

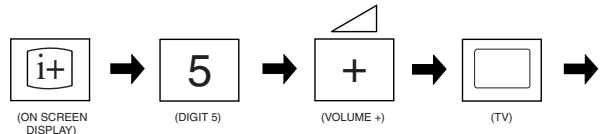

‘TT—’ will appear in the upper right corner of the screen. Other status information will also be displayed.

3. Press ‘MENU’ on the remote commander to obtain the Service menu on the screen.
4. Using the Remote Commander, Scroll to the ‘Error Menu’ item using the down arrow key, then press the right arrow key.
5. The following table will be displayed indicating the error count.

Flash Timing Example : e.g. error number 3

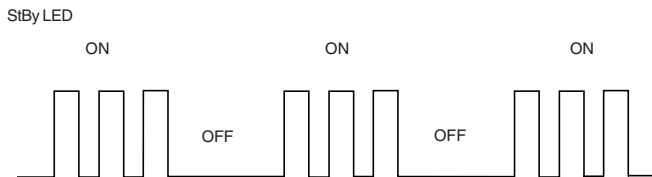

Table 2

ERROR MENU			
E02	OCP	(0, 255)	0
E03	OVP	(0, 255)	0
E04	VSYNC	(0, 255)	0
E05	IKR	(0, 255)	0
E06	IIC	(0, 255)	0
E07	NVM	(0, 255)	0
E08	HPROT	(0, 255)	0
E09	TUNER	(0, 255)	0
E10	SOUNDP	(0, 255)	0
E11	-	(0, 255)	0
E12	SCANRATE	(0, 255)	0
E13	DAC	(0, 255)	0
E14	BACKEND	(0, 255)	0
E15	DYN CON	(0, 255)	0
E16	PIP	(0, 255)	0
WORKING TIME			
HOURS			14
MINUTES			7

Note: To clear the error count data press ‘80’ on the Remote commander.

The operating instructions mentioned here are partial abstracts from the 'Operating Instruction Manual'. The page numbers of the 'Operating Instruction Manual' remain as in the manual.

Switching on the TV and Automatically Tuning

1 The first time you switch on your TV, a sequence of menu screens appear on the TV enabling you to:
 1) choose the language of the menu screen, 2) choose the country in which you wish to operate the TV,
 3) adjust the picture slant 4) search for and store all available channels (TV Broadcasts) and 5) change the order in which the channels (TV Broadcasts) appear on the screen.
 However, if you need to change any of these settings at a later date, you can do that by selecting the appropriate option in the **⊞** (Set Up menu) or by pressing the Auto Start Up Button **▶** on the TV set.

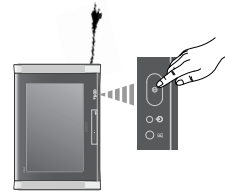

1 Connect the TV plug to the mains socket (220-240V AC, 50Hz).
 The first time that the TV set is connected, it is usually turned on.
 If the TV is off, press the **⊞** on/off button on the TV set to turn on the TV.
 The first time you switch on the TV, a **Language** menu appears automatically on the TV screen.

GB

2 Press the **⬆** or **⬇** button on the remote control to select the language, then press the **OK** button to confirm your selection. From now on all the menus will appear in the selected language.

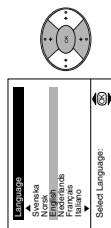

3 The **Country** menu appears automatically on the TV screen. Press the **⬆** or **⬇** button to select the country in which you will operate the TV set, then press the **OK** button to confirm your selection.

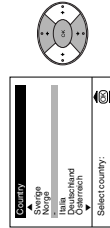

- If the country in which you want to use the TV set does not appear in the list, select "-" instead of a country.
- In order to avoid wrong teletext characters for Cyrillic languages we recommend you select Russia as the country if your own country does not appear in the list.

4 Because of the earth's magnetism, the picture might slant. The **Picture Rotation** menu allows you to correct the picture slant if it is necessary.



- a) If it is not necessary, press the **⬆** or **⬇** button to select **Not necessary** and press **OK**.
- b) If it is necessary, press the **⬆** or **⬇** button to select **Adjust now**, then press **OK** and correct any slant of the picture between -5 and +5 by pressing the **⬆** or **⬇** button. Finally press **OK** to store.

continued...

Switching on the TV and Automatically Tuning

5 The Auto Tuning menu appears on the screen. Press the **OK** button to select **Yes**.

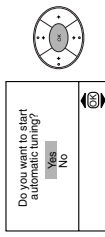

6 The TV starts to automatically search and store all available broadcast channels for you.

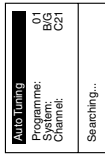

⚠ This procedure could take some minutes. Please be patient and do not press any buttons, otherwise the automatic tuning will not be completed.

⚠ If no channels were found during the auto tuning process then a new menu appears automatically on the screen asking you to connect the aerial. Please connect the aerial (see page 6) and press **OK**. The auto tuning process starts again.

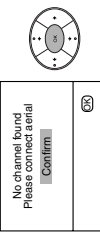

7 After all available channels are captured and stored, the **Programme Sorting** menu appears automatically on the screen enabling you to change the order in which the channels appear on the screen.

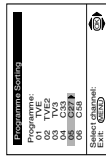

a) If you wish to keep the broadcast channels in their tuned order, go to step 8.

b) If you wish to store the channels in a different order:
 1 Press the **⬆** or **⬇** button to select the programme number that has the channel (TV Broadcast) you wish to rearrange, then press the **⬆** button.
 2 Press the **⬆** or **⬇** button to select the new programme number position for your selected channel (TV Broadcast), then press **⬆**.
 3 Repeat steps b)1 and b)2 if you wish to change the order of the other channels.

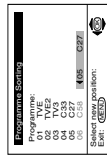

8 Press the **MENU** button to remove the menu from the screen.



👉 Your TV is now ready for use.

Introducing and Using the Menu System

 Your TV uses an on-screen menu system to guide you through the operations. Use the following buttons on the Remote Control to operate the menu system:

1 Press the **MENU** button to switch the first level menu on.



2

- To highlight the desired menu or option, press **▲** or **◆** button.
- To enter to the selected menu or option, press **▶**.
- To return to the last menu or option, press **◀**.
- To alter the settings of your selected option, press **◀/▶/▲/◆** or **◀**.
- To confirm and store your selection, press the **OK** button.

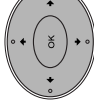

3 Press the **MENU** button to remove the menu from the screen.



GB

Menu Guide

Level 1

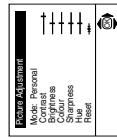

Level 2

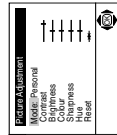

Level 3 / Function

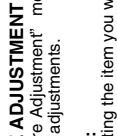

PICTURE ADJUSTMENT
The "Picture Adjustment" menu allows you to alter the picture adjustments.

To do this:
After selecting the item you want to alter, press the **▶** button, then repeatedly press the **▲/▼/◆/◀** or **▶** buttons to make any adjustments and finally press the **OK** button to store.

This menu also allows you to customise the picture mode based on the programme you are watching:

- ▶ **Personal** (for individual settings).
- ▶ **Live** (for live broadcast programmes, DVD and Digital Set Top Box receivers).
- ▶ **Movie** (for films).

- **Brightness, Colour and Sharpness** can only be altered if "Personal" mode is selected.
- **Hue** is only available for NTSC colour signal (e.g. USA video tapes).
- Select **Reset** and press the **OK** button to return the picture settings to their factory preset levels.

continued...

Introducing and Using the Menu System

Level 1

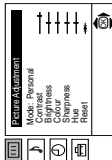

Level 2



Level 3 / Function

MANUAL PROGRAMME PRESET

The "Manual Programme Preset" option in the "Set Up" menu allows you to:

- Preset channels or the VCR channel one by one to the programme order of your choice.

To do this:

- After selecting the "Manual Programme Preset" option, press the **▶** button then with **Programme** option highlighted press the **▶** button. Press the **▲** or **◆** buttons to select the programme number you want to preset the channel to (for VCR, select programme number "0"). Then press the **▶** button.



- The availability of this option depends on the country you have selected in the "Language/Country" menu.

GB

After selecting the **System** option, press the **▶** button. Then press the **▲** or **◆** buttons to select the TV Broadcast system (**B/G** for western European countries or **D/K** for eastern European countries). Press the **▶** button.

- After selecting the **Channel** option, press the **▶** button. Then press the **▲** or **◆** buttons to select the channel tuning ("C" for terrestrial channels or "S" for cable channels). Next press **▶** button. After that, press the numbered buttons to directly enter the channel number of the TV Broadcast or the VCR channel. If you do not know the channel number, press the **▲** or **◆** buttons to search for it. When you have tuned to the desired channel, press the **OK** button twice to store.

Repeat all the above steps to tune and store more channels.

- Label a channel using up to five characters.

To do this:

After highlighting the **Programme** option, press the **PROG +/-** button to select the programme number of the channel you wish to name. When the programme you want to name appears on the screen, select the **Label** option and press **▶** button. Next press the **▲** or **◆** buttons to select a letter, number or "-" for a blank. Press the **▶** button to confirm the character. Select the other four characters in the same way. After selecting all the characters, press the **OK** button twice to store.

continued...

Introducing and Using the Menu System

Level 1	Level 2	Level 3 / Function
		<p>c) Manually fine tune the TV to obtain a better picture reception if the picture is distorted. Normally the automatic fine tuning (AFT) is in operation, but you can alter it manually.</p> <p>To do this:</p> <p>Whilst watching the channel (TV Broadcast) you wish to fine tune, select the AFT option and press ↔ button. Next press the ↔ or ↕ buttons to adjust the fine tuning between -15 and +15. Finally press the OK button twice to store.</p> <p>d) Skip any unwanted programme numbers when they are selected with the PROG +/- buttons.</p> <p>To do this:</p> <p>After highlighting the Programme option, press the PROG +/- button to select the programme number you want to skip. When the programme you want to skip appears on the screen, select the Skip option and press the ↔ button. Next press the ↔ or ↕ buttons to select Yes. Finally press the OK button twice to confirm and store.</p> <p>To cancel this function afterwards, select "No" instead of "Yes" in the step above.</p> <p>e) View and record scrambled channels when using a decoder connected directly to the Scart socket ↔-3/-↔-3 or through a VCR.</p> <p>To do this:</p> <p>The availability of this option depends on the country you have selected in the "Language/Country" menu.</p> <p>To do this:</p> <p>Select the Decoder option and press the ↔ button. Next press the ↔ or ↕ buttons to select On. Finally press the OK button twice to confirm and store.</p> <p>To cancel this function afterwards, select "Off" instead of "On" in the step above.</p>

Introducing and Using the Menu System

Level 1	Level 2	Level 3 / Function
		<p>AV3 OUTPUT</p> <p>The "AV3 Output" option in the "Detail Set Up" menu allows you to select the source to be output from the Scart connector ↔-3/-↔-3, so you can record from this Scart any signal coming from the TV or from external equipment connected to Scart connectors ↔-1/-↔-1 or ↔-2/-↔-2 or the front connectors ↔-4 or ↔-4 and ↔-4.</p> <p>To do this:</p> <p>If your VCR supports Smartlink, this procedure is not necessary.</p> <p>After selecting the option, press the ↔ button. Then press the ↔ or ↕ buttons to select the desired output signal: TV, AV1, AV2, AV4, YC4 or AUTO.</p> <p>GB</p> <p>If you select "AUTO", the output signal will always be the same one that is displayed on the screen.</p> <p>If you have connected a decoder to the Scart socket ↔-3/-↔-3 or to a VCR connected to that Scart socket, please remember to set the "AV3 Output" to "AUTO" or "TV" for correct unscrambling.</p>

Level 1	Level 2	Level 3 / Function
		<p>TV SPEAKERS</p> <p>The "TV Speakers" option in the "Detail Set Up" menu allows you to mute the TV speakers in order to listen to the TV from an external amplifier connected to the audio outputs on the rear of the TV set.</p> <p>To do this:</p> <p>After selecting the option, press the ↔ button. Then press the ↔ or ↕ buttons to select Off. Finally press the OK button to confirm and store.</p> <p>To cancel this function later on, select "On" instead of "Off" in the step above.</p>

Level 1	Level 2	Level 3 / Function
		<p>RGB CENTRING</p> <p>When connecting an RGB source, such as a "PlayStation", you may need to readjust the horizontal position of the picture. In that case, you can readjust it using the "RGB Centring" option in the "Detail Set Up".</p> <p>To do this:</p> <p>While watching an RGB source select the "RGB Centring" option and press the ↔ button. Then press the ↔ or ↕ buttons to adjust the centre of the picture between -10 and +10. Finally press the OK button to confirm and store.</p>

Level 1	Level 2	Level 3 / Function
		<p>NOISE REDUCTION</p> <p>The "Noise Reduction" option in the "Detail Set Up" menu allows you to automatically reduce any picture noise visible in the broadcast signal.</p> <p>To do this:</p> <p>After selecting the option, press the ↔ button. Then press the ↔ or ↕ buttons to select Auto. Finally press the OK button to confirm and store.</p> <p>To cancel this function later on, select "Off" instead of "Auto" in the step above.</p>

Level 1	Level 2	Level 3 / Function
		<p>AV3 OUTPUT</p> <p>The "AV3 Output" option in the "Detail Set Up" menu allows you to select the source to be output from the Scart connector ↔-3/-↔-3, so you can record from this Scart any signal coming from the TV or from external equipment connected to Scart connectors ↔-1/-↔-1 or ↔-2/-↔-2 or the front connectors ↔-4 or ↔-4 and ↔-4.</p> <p>To do this:</p> <p>If your VCR supports Smartlink, this procedure is not necessary.</p> <p>After selecting the option, press the ↔ button. Then press the ↔ or ↕ buttons to select the desired output signal: TV, AV1, AV2, AV4, YC4 or AUTO.</p> <p>GB</p> <p>If you select "AUTO", the output signal will always be the same one that is displayed on the screen.</p> <p>If you have connected a decoder to the Scart socket ↔-3/-↔-3 or to a VCR connected to that Scart socket, please remember to set the "AV3 Output" to "AUTO" or "TV" for correct unscrambling.</p>

continued...

Introducing and Using the Menu System

Level 1 / Function Level 2 Level 3 / Function

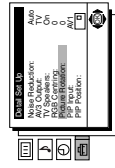
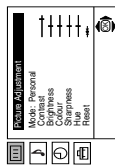

PICTURE ROTATION

Because of the earth's magnetism, the picture might slant. If this is the case, you can correct the pictures slant by using the option "Picture Rotation" in the "Detail Set Up" menu.

To do this:

After selecting the option, press the **➔** button. Then press the **⬆** or **⬇** buttons to correct any slant of the picture between -5 and +5 and finally press the **OK** button to store.

PIP INPUT

The "PIP Input" option in the "Detail Set Up" menu allows you to select which picture source you want to watch in the "PIP" screen.

To do this:

After selecting the option, press the **➔** button. Then repeatedly press the **⬆** or **⬇** buttons to select the desired source (AV1, AV2, AV3, AV4 or TV). Finally press the **OK** button to store.

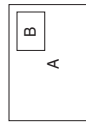
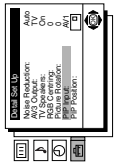
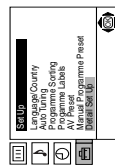
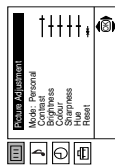

PIP POSITION

The "PIP Position" option in the "Detail Set Up" menu allows you to change the position of the "PIP" screen within the main screen.

To do this:

After selecting the option, press the **⬆**, **⬇**, **⬅** or **➔** button to select the desired position. Finally press the **OK** button to store.

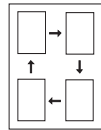
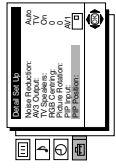
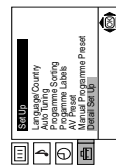
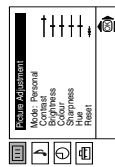

Teletext



Teletext is an information service transmitted by most TV stations. The index page of the teletext service (usually page 100) gives you information on how to use the service. To operate teletext, use the remote control buttons as indicated below.



Teletext errors may occur if you use a channel (TV Broadcast) with a weak signal.

To Switch on Teletext:

After selecting the TV channel which carries the teletext service you wish to view, press the **⏏** button.

To Select a Teletext page:

- Input the 3 digits of the page number, using the numbered buttons.
- If you have made a mistake, retype the correct page number.
- If the counter on the screen continues searching, it is because the page is not available. In that case, input another page number.

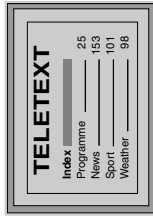

To access the next or preceding page:

Press **PROG + (⏏)** or **PROG - (⏏)** buttons.

To superimpose teletext onto the TV:

Whilst you are viewing teletext, press the **⏏** button. Press again to cancel teletext mode.

To freeze a teletext page:

Press the **⏏** button. Press again to cancel freeze.

To reveal concealed information (e.g. answer to a quiz):

Press the **⏏** button. Press again to conceal the information.

To select a sub page:

A teletext page may consist of several sub pages. In this case the page number that appears on the upper left corner changes colour from yellow to green, and one or more arrows will appear next to the page number. Repeatedly press the **⬆** or **⬇** buttons on the remote control to watch the desired sub page.

To Switch Off Teletext:

Press **⏏** button.

Fastext

The Fastext service lets you access pages with one button push. While you are in Teletext mode and providing Fastext is broadcast, a colour coded menu appears at the bottom of the teletext page. Press one of the coloured buttons (red, green, yellow or blue) to access the corresponding page.

Connecting Additional Equipment

Using the following instructions you can connect a wide range of optional equipment to your TV set. (Connecting cables are not supplied).

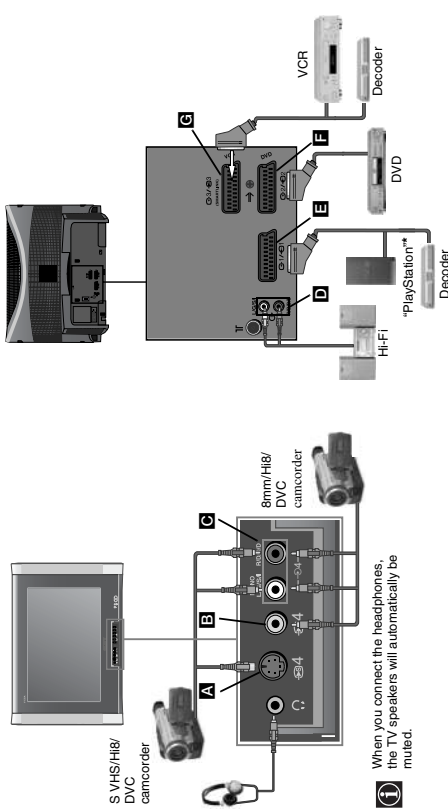

* **PlayStation**™ is a product of Sony Computer Entertainment, Inc.
 * **PlayStation**™ is a trademark of Sony Computer Entertainment, Inc.

A • To avoid picture distortion, do not connect external equipment to connectors **A** and **B** at the same time.
E • Do not connect a Decoder to the Scart connector **F**.

Connecting a VCR:
 To connect a VCR, please refer to the section "Connecting the aerial and VCR" of this instruction manual. We recommend you connect your VCR using a Scart lead. If you do not have a Scart lead, tune in the VCR test signal to the TV programme number "0" by using the "Manual Programme Preset" option. (for details of how to manually programme these presets, see page 13, step a). Refer to your VCR instruction manual to find out the output channel of your VCR.

Connecting a VCR that supports Smartlink:
 Smartlink is a direct link between the TV set and the VCR. For more information on Smartlink, please refer to the instruction manual of your VCR.
 If you use a VCR that supports Smartlink, please connect the VCR by using a Scart lead to the Scart socket **3-3/3 G**.

If you have connected a decoder to the Scart 3-3/3 G or through a VCR connected to this Scart:
 Select the "Manual Programme Preset" option in the "Set Up" menu and after selecting the "Decoder" option, select "On" (by using the **4** or **4** button). Repeat this procedure for each scrambled signal.
 ** The availability of this option depends on the country you have selected in the "Language/Country" menu.

continued...

Connecting Additional Equipment

Connecting to external Audio Equipment:
 Plug in your Hi-Fi equipment to the audio output sockets **D** if you wish to amplify the audio output from your TV. Next, using the menu system, select the "Set Up" menu. Enter the "Detail Set Up" menu and set "TV Speakers" to "Off".

The audio level of the external speakers can be modified by pressing the volume buttons on the remote control. Also, treble and bass settings can be modified through the "Sound Adjustment" menu.

To enjoy "Dolby Virtual" sound effect through your Hi-Fi equipment:

Place the speakers of your equipment in front of your sitting position and besides the TV set, but keeping a distance of 50 cm from each speaker to the TV set.
 Then, using the menu system, select the menu "Sound Adjustment", and select "Dolby Virtual" on the "Effect" option.

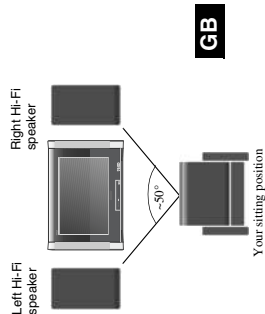

Using optional Equipment

- 1 Connect your equipment to the designated TV socket, as indicated in the previous page.
- 2 Switch on the connected equipment.
- 3 To watch the picture from the connected equipment, press the **4** button repeatedly until the correct input symbol appears on the screen.

Symbol Input Signals

- 4-1** • Audio / video input signal through the Scart connector **E**.
 - 4-1** • RGB input signal through the Scart connector **E**. This symbol appears only if a RGB source has been connected.
 - 4-2** • Audio / video input signal through the Scart connector **F**.
 - 4-2** • RGB input signal through the Scart connector **F**. This symbol appears only if a RGB source has been connected.
 - 4-3** • Audio/video input signal through the Scart connector **G**.
 - 4-3** • S Video input signal through the Scart connector **G**. This symbol appears only if a S Video source has been connected.
 - 4-4** • Video input signal through the phono socket **B** and Audio input signal through phono socket **C**.
 - 4-4** • S Video input signal through the front S Video input jack **A** and Audio signal through phono socket **C**. This symbol appears only if a S Video source has been connected.
- 4** Press **4** button on the remote control to return to the normal TV picture.

For Mono Equipment

Connect the phono plug to the L/G/S/I socket on the front of the TV and select **4-4** or **4-4** input signal using the instructions above. Finally, refer to the "Sound Adjustment" section of this manual and select "Dual Sound" "A" on the sound menu screen.

Specifications











TV system	Depending on your country selection B/G/H, D/K
Colour System	PAL, SECAM NTSC 3.58, 4.43 (Video In only)
Channel Coverage	VHF: E2-E12 UHF: E21-E69 CATV: S1-S20 HYPER: S21-S41 D/K: R1-R12, R21-R69
Picture Tube	Flat display FD Trinitron 29" (approx. 73cm measured diagonally)
Rear Terminals	<p>1 21-pin Scart connector (CENELEC standard) including audio/video input, RGB input, TV audio/video output</p> <p>2 21-pin Scart connector (CENELEC standard) including audio/video input, RGB input, monitor audio/video output</p> <p>3 21-pin Scart connector (CENELEC standard) including audio/video input, S-video input, selectable audio/video output and Smartlink interface</p> <p>4 Audio outputs (Left/Right) - phono jacks</p>
Front terminals	<p>4 S Video input - 4 pin DIN</p> <p>4 Video input - phono jack</p> <p>4 Audio input - phono jacks</p> <p>1 Headphones jack</p>
Sound Output	2 x 20W (Music Power), 2 x 10W (RMS) Wooler: 30W (Music Power), 15W (RMS)
Power Consumption	130W
Standby Power Consumption	0.3W
Dimensions (WxHxD)	Approx. 771mm x 585mm x 506mm
Weight	Approx. 48.5kg
Accessories Supplied	1 Remote Control (RM-944), 2 batteries (IEC designated)
Other Features	<ul style="list-style-type: none"> 100Hz picture Teletext, Fastext, TOPtext (250 page TEXT memory) Sleep Timer Smartlink (direct link between your TV set and a compatible VCR. For more information on Smartlink, please refer to the Instruction Manual of your VCR) TV system Autodetection Dolby Virtual BBE PIP

Design and specifications are subject to change without notice.

 100% Recycled Paper - Totally Chlorine Free

Troubleshooting

 Here are some simple solutions to problems which may affect the picture and sound.

Problem	Suggested Remedy
No picture (screen is dark), and no sound.	<ul style="list-style-type: none"> Check the aerial connection. Plug the TV in and press the  button on the front of the TV. If the standby indicator  is on press the  button or a numbered button on the remote control.
Poor or no picture (screen is dark), but good sound.	<ul style="list-style-type: none"> Using the MENU system, select the "Picture Adjustment" display and select "RESET" to return to the factory settings.
No picture or menu information from equipment connected to the Scart socket.	<ul style="list-style-type: none"> Check that the optional equipment is on, and press the  button of the remote control repeatedly until the correct input symbol is displayed on screen.
Good picture, no sound.	<ul style="list-style-type: none"> Press the  button on the remote control. Check that "TV Speakers" is "On" in the "Detail Set Up" menu. Check the Headphones are not connected.
No colour on colour programmes.	<ul style="list-style-type: none"> Using the MENU system, select the "Picture Adjustment" and select "RESET" to return to the factory settings.
Distorted picture when changing programmes or selecting Teletext.	<ul style="list-style-type: none"> Turn off any equipment connected to the scart connectors on the rear of the TV.
Wrong characters appear when viewing teletext.	<ul style="list-style-type: none"> Using the menu system, display the "Language/Country" menu and select the country in which you are operating the TV set. For cyrillic languages, we recommend selecting "Russia" if your own country does not appear in the list
Picture slanted.	<ul style="list-style-type: none"> Using the menu system, select the "Picture Rotation" option in the "Detail Set Up" menu to correct the picture slant.
Snowy picture when viewing a TV channel.	<ul style="list-style-type: none"> Using the menu system, select the "Manual Programme Preset" menu and adjust Fine Tuning (AFT) to obtain better picture reception. Using the menu system, select the "Noise Reduction" option in the "Detail Set Up" menu and select "Auto" to reduce the noise in the picture.
No unscrambled picture whilst viewing an unscrambled channel with a decoder connected through the scart connector  -  3.	<ul style="list-style-type: none"> Using the menu system, display the "Set Up" menu. Then select the "Detail Set Up" option and set "AV3 Output" to "TV". Check that the decoder is not connected to the -2 scart socket.
Remote control does not function.	<ul style="list-style-type: none"> Replace the batteries.
The standby indicator  on the TV flashes.	<ul style="list-style-type: none"> Contact your nearest Sony service centre.

- If you continue to have problems, have your TV serviced by qualified personnel.
- NEVER open the casing yourself.

GB

SECTION 2 DISASSEMBLY

2-1. Rear Cover Removal



Remove the rear cover fixing screws indicated and pull the rear cover backwards away from the set.

2-2. Speaker Connector Disconnection

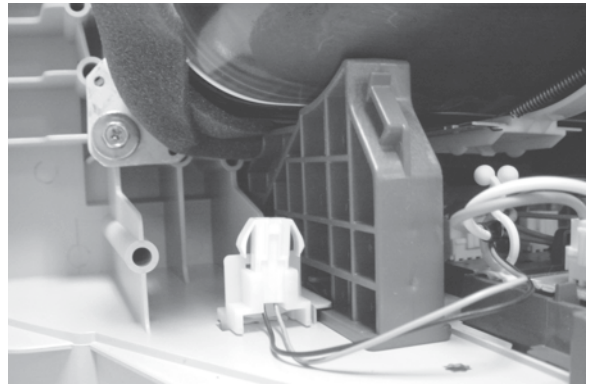

Before completely removing the rear cover disconnect the speaker connector which is located on the inside of the set.

2-3. Chassis Removal and Refitting

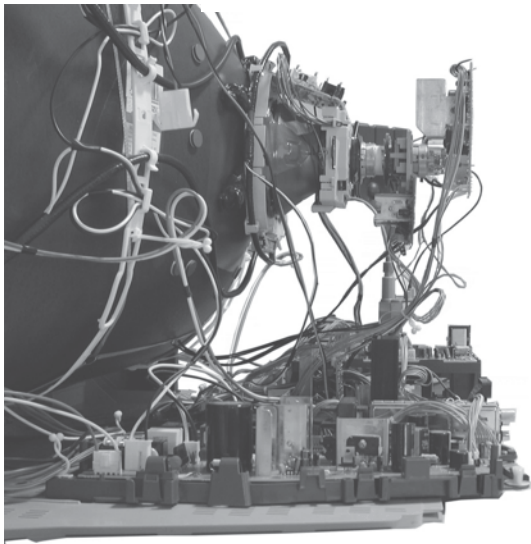

To remove lift the main bracket rear slightly and slide the chassis away from the beznet. Ensure that the interconnecting leads are released from their purse locks to prevent damage being caused.

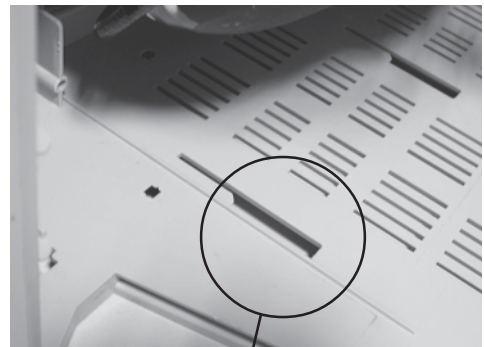

When refitting the chassis ensure that the main bracket is located in the beznet guide slots before sliding the chassis forwards. Refit the inter-connecting leads in their respective purse locks.

2-4. Service Position

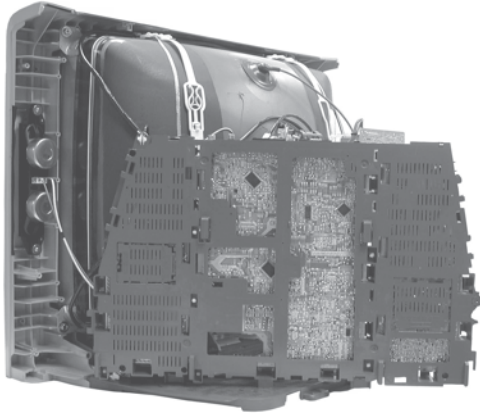

To place the chassis in the service position, remove the H bracket and stand the chassis as shown above. To gain access to the underside of the boards follow the instructions on page 16. [Removal and Replacement of the main bracket bottom plates].

2-5. G Board Removal

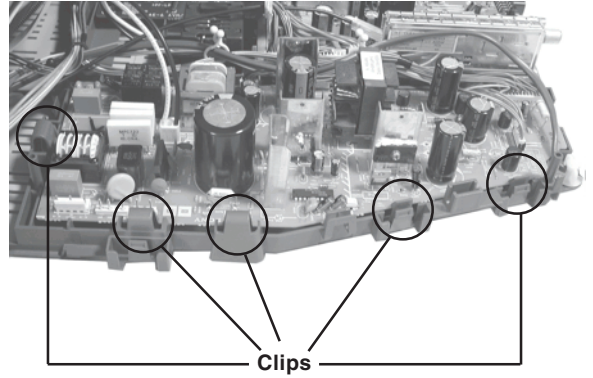

To remove the G Board release the clips circled and ease the board gently away from the support bracket. Removal of the D board follows the same procedure.

2-6. Service Connector for M Board

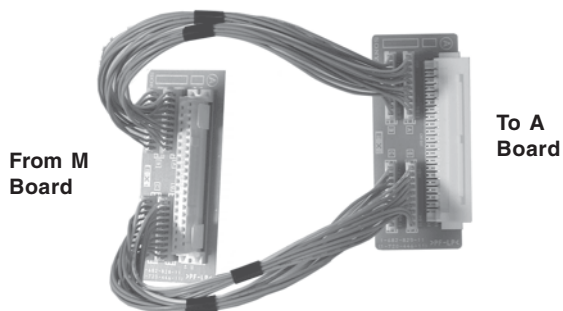

Extender Board Assembly A-1642-293-A

If the M Board needs to be removed for testing when the chassis is placed in its service position, it would be necessary to use an extender board and extension cable as indicated above. The Extender board and extension cable are available as a service part by ordering the part number as indicated.

2-7. Wire Dressing

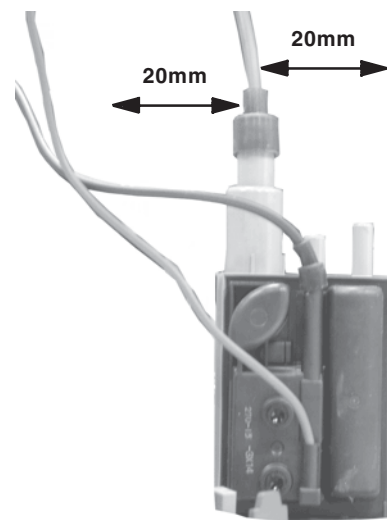

Ensure that wires do not touch heatsinks and high temperature hotspots. All wires must be kept at a minimum distance of 20mm away from the EHT lead

2-8. Picture Tube Removal

WARNING: BEFORE REMOVING THE ANODE CAP

High voltage remains in the CRT even after the power is disconnected. To avoid electric shock, discharge CRT **before** attempting to remove the anode cap. Short between anode and CRT coated earth ground strap.

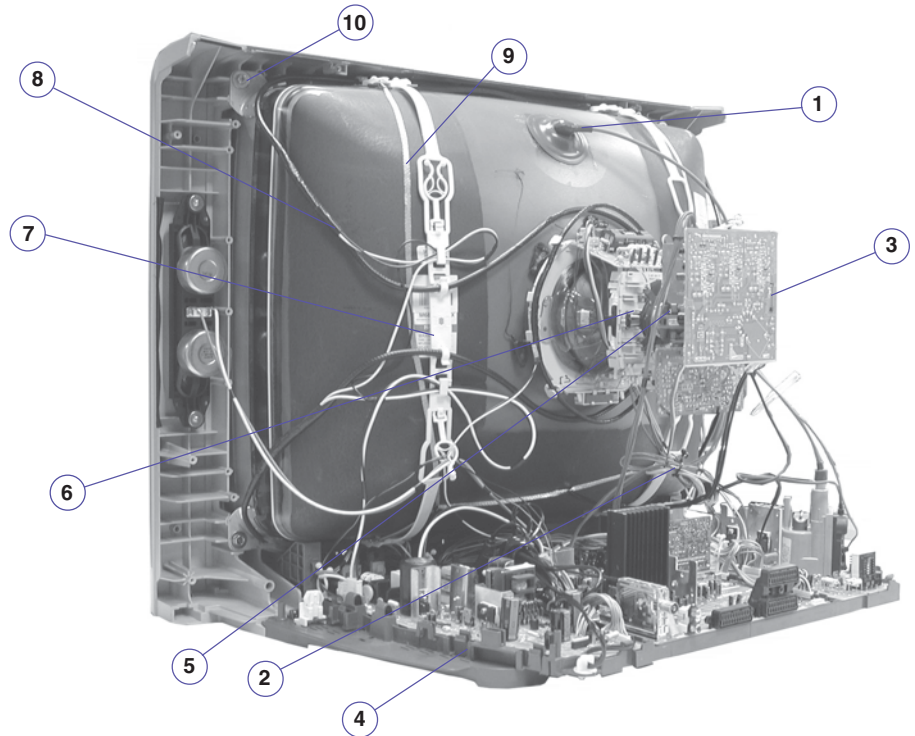
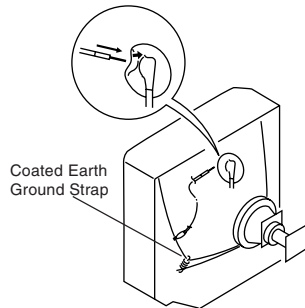

1. Discharge the anode of the CRT and remove the anode cap.
2. Unplug all interconnecting leads from the Deflection yoke, neck assy, degaussing coils and CRT grounding strap.
3. Remove the C Board from the CRT.
4. Remove the chassis assembly.
5. Loosen the Neck assembly fixing screw and remove.
6. Loosen the Deflection yoke fixing screw and remove.
7. Place the set with the CRT face down on a cushion and remove the Degaussing Coil holders.
8. Remove the Degaussing Coils.
9. Remove the CRT grounding strap and spring tensioners.
10. Unscrew the four CRT fixing screws [located on each CRT corner] and remove the CRT.
[Take care not to handle the CRT by the neck.]

Removal of the Anode-Cap

REMOVAL PROCEDURE.

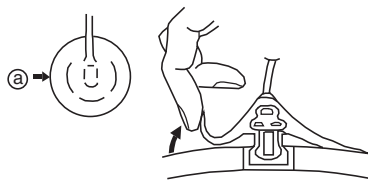

- ① Turn up one side of the rubber cap in the direction indicated by the arrow (a)

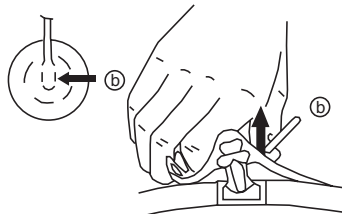

- ② Using a thumb pull up the rubber cap firmly in the direction indicated by the arrow (b)

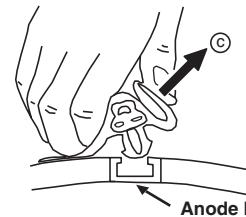

- ③ When one side of the rubber cap is separated from the anode button, the anode-cap can be removed by turning up the rubber cap and pulling it up in the direction of the arrow (c)

How to handle the Anode-Cap

1. To prevent damaging the surface of the anode-cap do not use sharp materials.
2. Do not apply too great a pressure on the rubber, as this may cause damage to the anode connector.
3. A metal fitting called a shatter hook terminal is fitted inside the rubber cap.
4. Do not turn the rubber foot over excessively, this may cause damage if the shatter hook sticks out.

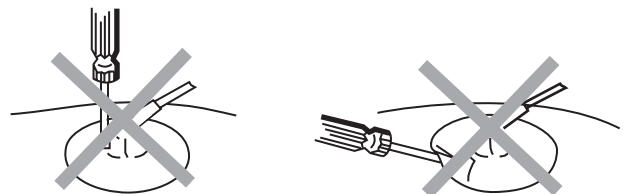

REMOVAL AND REPLACEMENT OF THE MAIN-BRACKET BOTTOM PLATES.

(1) REMOVING THE PLATES

In the event of servicing being required to the solder side of the printed wiring boards, the bottom plates fitted to the main chassis bracket require to be removed. This is performed by cutting the gates with a sharp wire cutter at the locations indicated by the arrows.

Note : There are 2 plates fitted to the main bracket. Only remove the necessary plate to gain access to the printed wiring board.

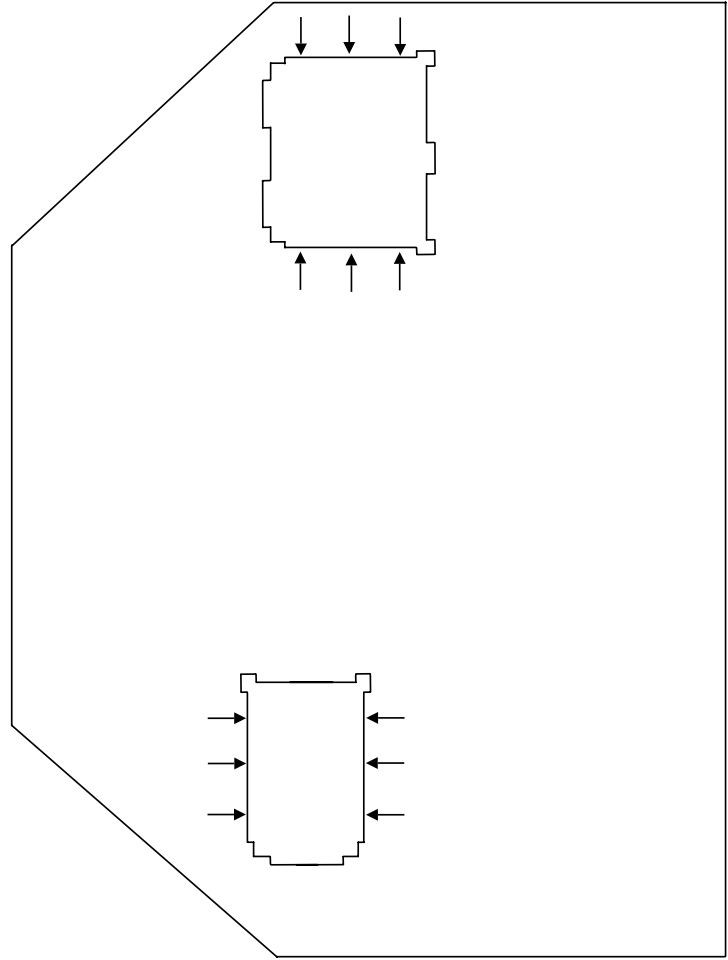

For safety reasons, on no account should the plates be removed and not refitted after servicing.

(2) REFITTING THE PLATES

Because the plates differ in size it is important that the correct plates are refitted in their original location.

Please note that the plates need to be rotated 180 degrees from their cut position to allow the tabs to be fitted into their catch positions.

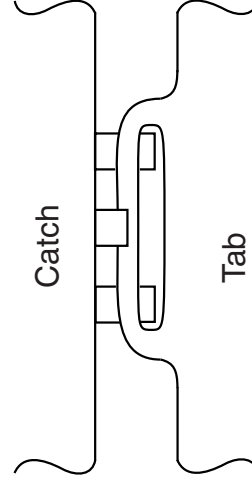

SECTION 3 SET-UP ADJUSTMENTS

- When complete readjustment is necessary or a new picture tube is installed, carry out the following adjustments.
- Unless there are specific instructions to the contrary, carry out these adjustments with the rated power supply.
- Unless there are specific instructions to the contrary, set the controls and switches to the following settings :

Contrast normal
 Brightness normal

Carry out the adjustments in the following order :

- 3-1. Beam Landing.
- 3-2. Convergence.
- 3-3. Focus.
- 3-4. White Balance.

Note : Test equipment required.

1. Color bar/pattern generator.
2. Degausser.
3. Oscilloscope.
4. Digital multimeter.

3-1. Beam Landing

Preparation :

1. In order to reduce the influence of geomagnetism on the set's picture tube, face it in an easterly or westerly direction.
2. Switch on the TV set's power and degauss with a degausser.

(1) Adjustment of Correction Magnet for Y-Splitting Axis.

1. Input a crosshatch signal from the pattern generator.
2. Set the Picture control to minimum and confirm that the Brightness control is set to normal.
3. Position the neck assembly as indicated in Fig.3-2.
4. Loosen the deflection yoke fixing screw.
5. Move the deflection yoke as far forward as is possible.
6. Adjust the upper and lower pin symmetrically by opening or closing the Y-splitting axis correction magnets located on the neck assembly. [See Fig 3-3]
7. Return the deflection yoke to its original position and re-tighten its fixing screw.

Fig.3-1

Y-splitting axis correction magnet

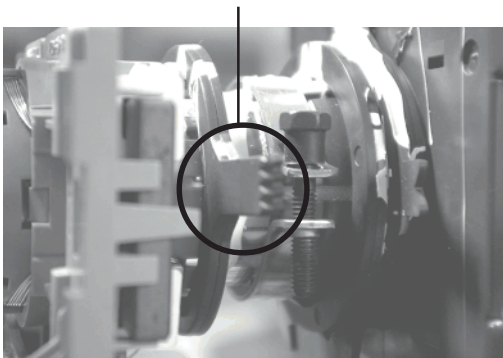

Caution :

High voltages are present on the Deflection yoke terminals - take care when handling the Deflection yoke whilst carrying out adjustments.

(2) Landing

Note : Before carrying out the following adjustments adjust the magnets as indicated [See Fig.3-4].

1. Input a crosshatch signal from the signal generator.
2. Rough-adjust the focus and horizontal convergence.
3. Switch from the crosshatch pattern to an all-red pattern.
4. Move the deflection yoke backwards and adjust with the purity magnet so that the red is at the centre and it aligns symmetrically [See Fig.3-5].
5. Move the deflection yoke forward to the point where the entire screen just becomes red [Mark its position].
6. Move the deflection yoke further forward until the screen just changes colour at the edges. [Mark its position]
7. Position the deflection yoke between the two marks indicated above.
8. Input a crosshatch pattern from the pattern generator and rotate the deflection yoke so that the horizontal lines are parallel with the top and bottom of the screen.
9. When the position of the deflection yoke has been determined, fasten it with its fixing screw.
10. Switch the pattern generator to green then blue and confirm the purity.
11. If the beam does not land correctly in all the corners of the screen, use disk magnets to correct it. [Confirm the corner landing for green and blue]

Fig.3-2

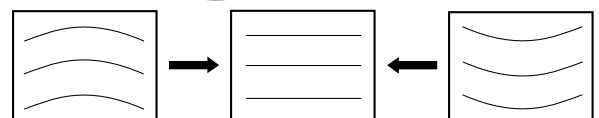
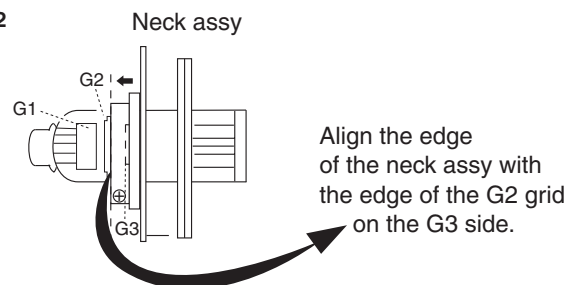

Fig.3-3

Fig.3-4

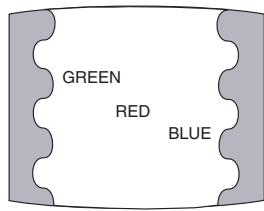
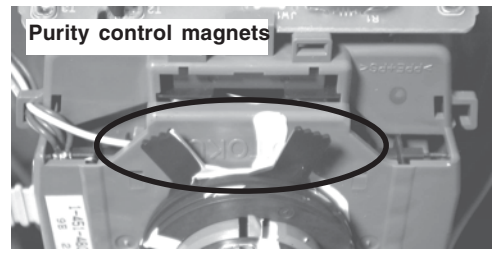
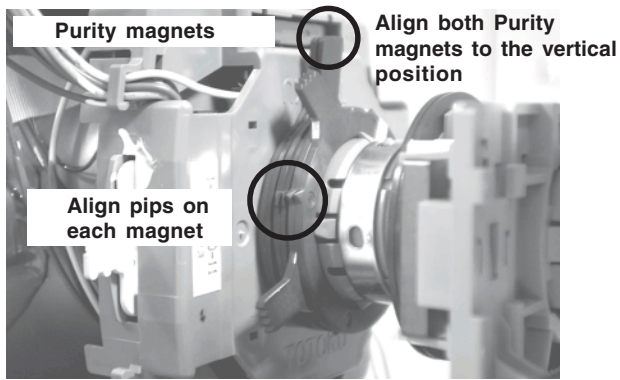
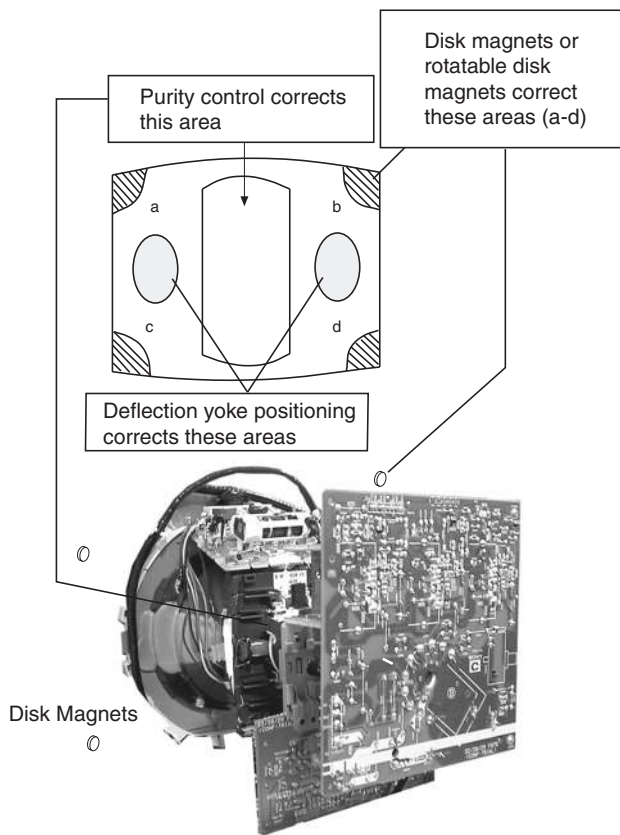

Fig.3-5



3-2. Convergence

(1) Screen centre convergence [Static convergence]

1. Input a dot pattern signal from the pattern generator.
2. Normalize the picture setting.
3. [Moving vertically], adjust the V.STAT magnet so that the vertical red, green and blue dots coincide at the centre of the screen.

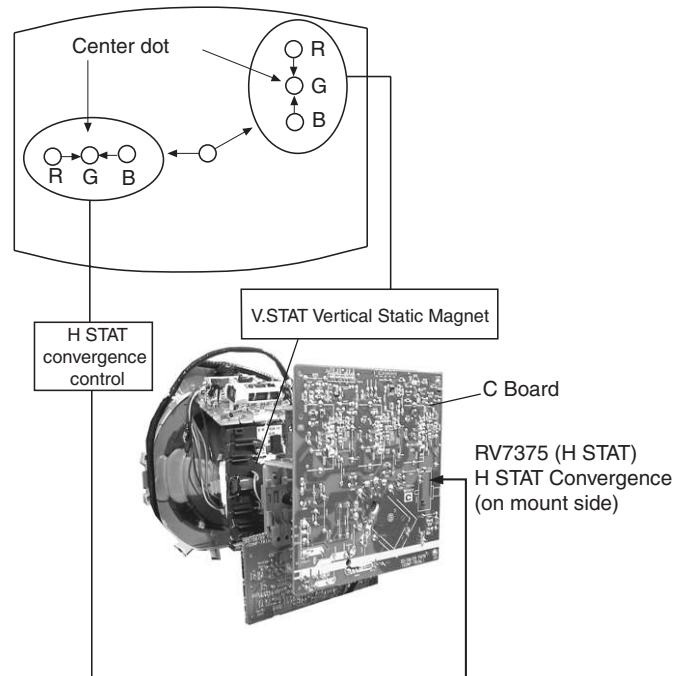

By opening or closing the V.STAT magnet, the red green and blue dots move in the direction indicated below.

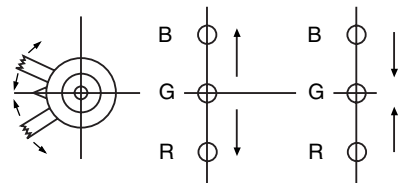

Note: Do not adjust the H.STAT by rotating the V.STAT magnets as this can affect the focus setting.

4. Correction for HMC [Horizontal mis-convergence] and VMC [Vertical mis-convergence] by using the BMC [Hexapole] magnet.

a). HMC correction by BMC [Hexapole] magnet and movement of the electron beam.

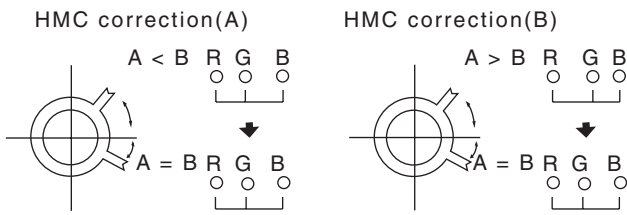

b). VMC correction by BMC [Hexapole] magnet and movement of the electron beam.

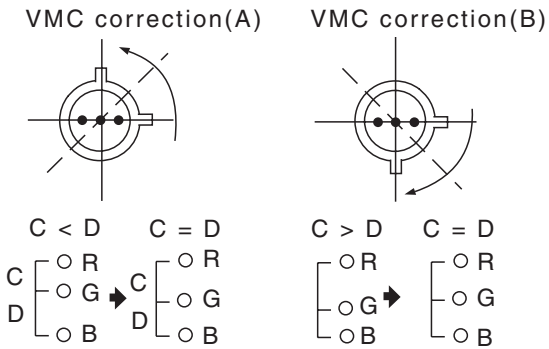

HAMP Adjustment

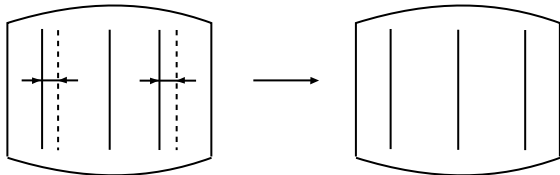

Adjust the HAMP using HAMPL and HAMPR registers in the Dynamic Convergence section of the service menu.

HTIL Adjustment

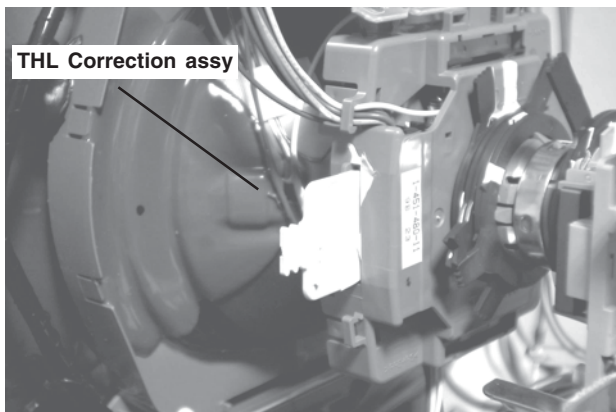

HTIL correction can be performed by adding a THL correction assembly to the Deflection yoke.

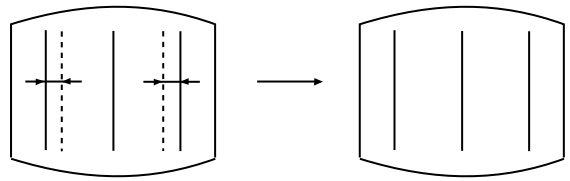

YCH Adjustment

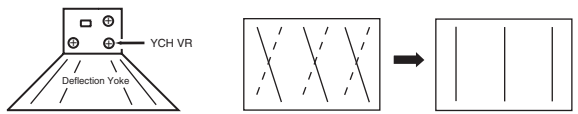

TLV Adjustment



H-TRAP Adjustment

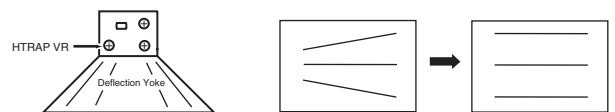

The H-TRAP should not be adjusted unless absolutely necessary as it affects the TLV settings.

Layout of each control

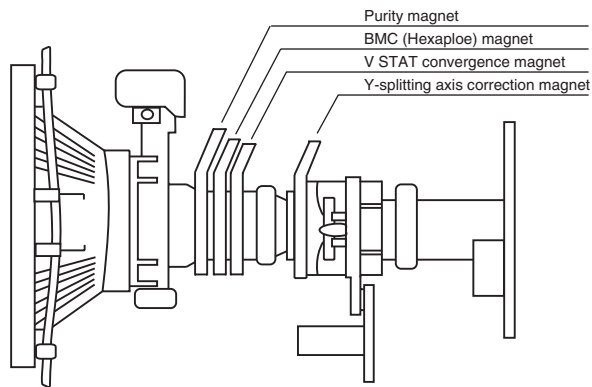

Note : If you are unable to adjust the corner convergence properly, this can be corrected with the use of permalloy magnets.

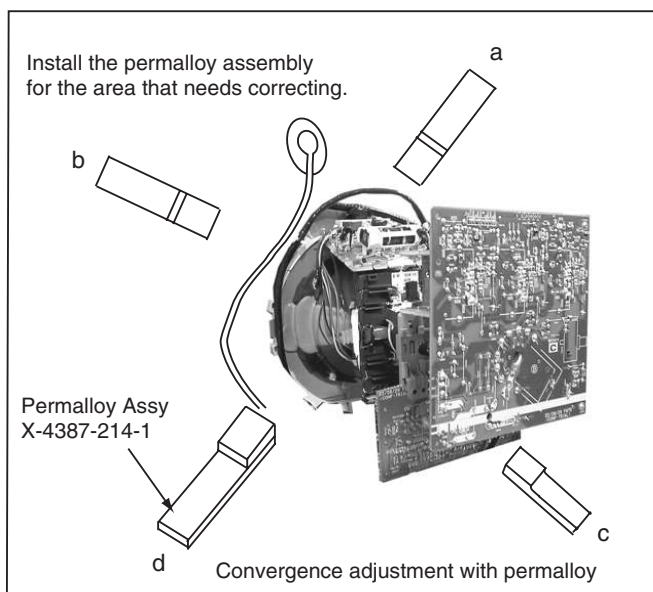
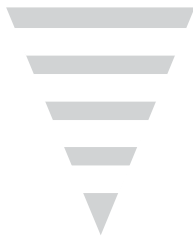
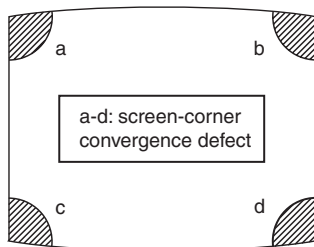

3-3. Focus Adjustment

1. Receive a television broadcast signal.
2. Normalize the picture setting.
3. Adjust the focus control located on the flyback transformer to obtain the best focus at the centre of the screen. Bring only the centre area of the screen into focus, the magenta-tinging appears on the screen. In this case, adjust the focus to optimize the screen uniformly.

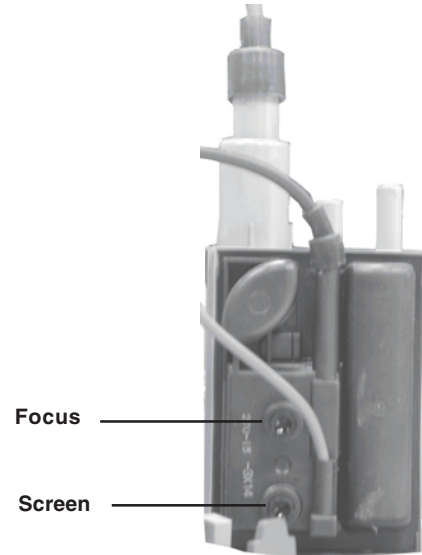

3-4. Screen (G2), White Balance

[Adjustment in the service mode using the remote commander]

G2 adjustment

1. Input a dot signal from the pattern generator.
2. Set the Picture, Brightness and Colour to minimum.
3. Apply 165V DC from an external power supply to the R, G and B cathodes of the CRT.
4. Whilst watching the picture, adjust the G2 control [SCREEN] located on the flyback transformer to the point just before the flyback return lines disappear.

White balance adjustment for TV mode

1. Input an all-white signal from the pattern generator.
2. Set the TV set or operation in Service Mode. [See Page 21].
3. Select 'Service' from the on screen menu display and press 'Right Arrow'.
4. The 'Service' menu will appear on the screen.[See Page 22]
5. Set the 'Contrast' to MAX.
6. Set the 'R-Drive' to 50.
7. Adjust the 'G-Drive' and the 'B-Drive' so that the white balance becomes optimum.
8. Press the 'OK' button to write the data for each item.
9. Set the 'Contrast' to MIN.
10. Set the 'R-Cutoff' to 29.
11. Adjust the 'G-Cutoff', and the 'B-Cutoff' with the left and right buttons on the remote commander so that the white balance becomes optimum.
12. Press the 'OK' button to write the data for each item.

SECTION 4 CIRCUIT ADJUSTMENTS

4-1. Electrical Adjustments

Service adjustments to this model can be performed using the supplied remote Commander RM-944 (KV-29XL70) or RM-934 (KV-29XL71).

How to enter into the Service Mode

1. Turn on the main power switch and enter into the stand-by mode.
2. Press the following sequence of buttons on the Remote Commander.

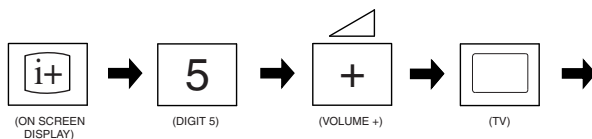

‘TT—’ will appear in the upper right corner of the screen.
Other status information will also be displayed.

3. Press ‘MENU’ on the remote commander to obtain the following menu on the screen.

Geometry
Service
Scanrate
DAC
Dyn. Conv.
PIP
Sound
IF adjust
Error Menu

AE6B v4.20 (Dic 03)
Factory data FFh FFh
MSP/Scan/IFOB: MSP3411G/9402-13/ON

4. Move to the corresponding adjustment item using the up or down arrow buttons on the Remote Commander.
5. Press the right arrow button to enter into the required menu item.
6. Press the ‘Menu’ button on the Remote Commander to quit the Service Mode when all adjustments have been completed.

Note :

- After carrying out the service adjustments, to prevent the customer accessing the ‘Service Menu’ switch the TV set OFF and then ON.

GEOMETRY

ABL TH	(0, 3)	0
ABL MODE	(0, 3)	0
P ABL	(0, 15)	15
V SIZE	(0, 63)	35
V POSITION	(0, 63)	33
V COMP	(0, 3)	1
V LIN	(0, 15)	7
S CORRECTION	(0, 15)	7
H SIZE	(0, 63)	44
PIN AMP	(0, 63)	32
UP CORNERPIN	(0, 63)	29
M PIN	(0, 3)	2
LO CORNERPIN	(0, 63)	29
TRAPEZIUM	(0, 15)	2
H POSITION	(0, 63)	40
AFC BOW	(0, 15)	8
AFC ANGLE	(0, 15)	9
LEFT BLK	(0, 63)	34
RIGHT BLK	(0, 63)	17
V ASPECT	(0, 63)	47
AKBTIM1	(0, 3)	2
AKBTIM2	(0, 1)	0
IKR		1
HNG		0
VNG		0

DYN. CONV.

RANGE	(0, 63)	63
YupL	(0, 1)	0
VAL	(0, 63)	30
YlowL	(0, 1)	0
VAL	(0, 63)	31
MBOWupL	(0, 1)	0
VAL	(0, 63)	31
MBOWlowL	(0, 1)	0
VAL	(0, 63)	32
HAMPL	(0, 1)	0
VAL	(0, 63)	37
YupR	(0, 1)	0
VAL	(0, 63)	30
YlowR	(0, 1)	0
VAL	(0, 63)	30
MBOWupR	(0, 1)	0
VAL	(0, 63)	32
MBOWlowR	(0, 1)	0
VAL	(0, 63)	32
HAMPR	(0, 1)	0
VAL	(0, 63)	36
UP Y	(0, 1)	0
VAL	(0, 63)	31
LOW Y	(0, 1)	0
VAL	(0, 63)	33
H STAT	(0, 1)	0
VAL	(0, 63)	33
UP CORR	(0, 1)	0
VAL	(0, 63)	34
LOW CORR	(0, 1)	0
VAL	(0, 63)	19

IF ADJUST			
Automute		1	
Audio Gain		0	
L Gating		0	
AGC TOP	(-16, +15)		-6

SERVICE		
SUB COL	(0, 63)	Adj 31
SUB HUE	(0, 63)	31
SUB SHARP	(0, 63)	30
SUB BRIGHT	(0, 63)	13
SUB CONT	(0, 15)	12
R-DRIVE	(0, 63)	50
G-DRIVE	(0, 63)	Adj
B-DRIVE	(0, 63)	Adj
R CUTOFF	(0, 63)	28
G CUTOFF	(0, 63)	24
B CUTOFF	(0, 63)	46
Br TXT	(0, 15)	7
Br OSD	(0, 15)	10

DAC			
CONFIG			00000000
MPIN CONT	(0, 255)		96
HLIN	(0, 255)		83
HTRAP	(0, 255)		127
ROT. COIL	(0, 255)		130
PHOCUS PH	(0, 255)		90

SOUND			
M-N	(0, 511)		200
M-D	(-128, -1)		-20
M-S	(+0, +127)		+20
S-M	(+0, +127)		+10
D-M	(-128, -1)		-10
N-M	(0, 1023)		496
BBE	(+0, +68)		+28
B1	(-96, +96)		+0
B2	(-96, +96)		+0
B3	(-96, +96)		+0
B4	(-96, +96)		+0
B5	(-96, +96)		+0
SW L	(-128, +0)		+0
SW F	(+5, +40)		+30
NICAM C AD		00000	
NICAM Error	(0, 2047)		0
Stereo	(-128, +127)		+0
Status			000000110

ERROR MENU

E02	OCP	(0, 255)	0
E03	OVP	(0, 255)	0
E04	VSYNC	(0, 255)	0
E05	IKR	(0, 255)	0
E06	IIC	(0, 255)	0
E07	NVM	(0, 255)	0
E08	HROT	(0, 255)	0
E09	TUNER	(0, 255)	0
E10	SOUNDP	(0, 255)	0
E11	-	(0, 255)	0
E12	SCANRATE	(0, 255)	0
E13	DAC	(0, 255)	0
E14	BACKEND	(0, 255)	0
E15	DYN CON	(0, 255)	0
E16	PIP	(0, 255)	0

WORKING TIME

HOURS	14
MINUTES	7

Sub Brightness Adjustment

1. Input a Monoscope pattern.
2. Set the TV set or operation in Service Mode.
[See Page 21].
3. Select 'Service' from the on screen menu display and press 'Right Arrow'.
4. The 'Service' menu will appear on the screen.
5. Adjust the 'Sub-Brightness' data so that there is barely a difference between the 0 IRE and 10 IRE signal levels.

Sub Contrast Adjustment

1. Input a video signal that contains a small 100% white area on a black background.
2. Connect an digital voltmeter to Pin 10 of J7375 [C Board].
3. Set the TV set or operation in Service Mode.
[See Page 21].
4. Select 'Service' from the on screen menu display and press 'Right Arrow'.
5. The 'Service' menu will appear on the screen.
6. Adjust the Sub-Contrast to obtain a voltage of 105 +/- 5V.

Sub Colour Adjustment

1. Receive a PAL colour bar signal.
2. Connect an oscilloscope to Pin 6 of CN7001 [A Board].
3. Set the TV set or operation in Service Mode.
[See Page 21].
4. Select 'Service' from the on screen menu display and press 'Right Arrow'.
5. The 'Service' menu will appear on the screen.
6. Adjust the 'Sub Colour' so that the Cyan, Magenta and Blue colour bars are of equal levels as indicated below.

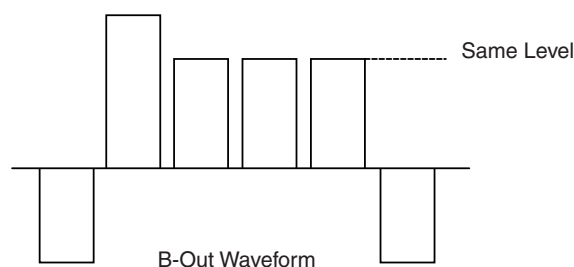

Deflection System Adjustment

1. Set the TV set or operation in Service Mode.
[See Page 21].
2. Select 'Geometry' from the on screen menu display and press 'Right Arrow'.
3. The 'Geometry' menu will appear on the screen.[See Page 21]
4. Select and adjust each item in order to obtain the optimum image.

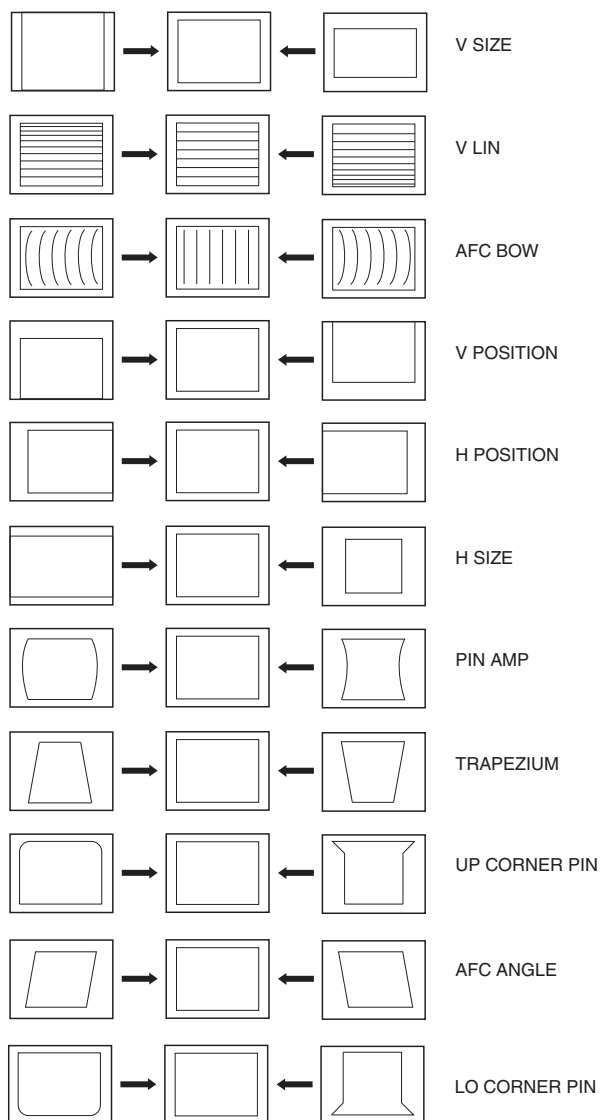

4-2. TEST MODE 2:

Test Mode 2 is available by setting the TV for operation in Service Mode [As shown on Page 21] , OSD 'TT' appears. The functions described below are available by selecting the two numbers. To release the 'Test mode 2', press 00, 10, 20 ... twice or switch the TV set into Stand-by mode. In 'TT Menu' mode, it is possible to remove the Menu from the screen by pressing the Speaker Off button once. Pressing the Speaker OFF button a second time will cause the Menu to reappear. The function is kept even when the menu is not displayed on screen !!.

00	'TT' mode off
01	Picture maximum
02	Picture minimum
03	Set speaker/headphone Volume to 35%
04	Set speaker/headphone Volume to 50%
05	Set speaker/headphone Volume to 65%
06	Set speaker/headphone Volume to 80%
07	Ageing mode
08	Shipping Condition
11	Sub picture adjustment
12	Sub colour adjustment
13	Sub Brightness adjustment
14	Text H Position adjustment
15	Rotation Coil Test
16	Picture level 50%
19	Factory Mode Enable/Disable
21	Destination ADEKR
22	Destination BL
23	Destination ADEKR
24	Destination U
25	Destination ADEKR
26	Destination BL
27	Destination ADEKR
28	Destination ADEKR
31	Auto Shutoff Enable/Disable
36	Velocity Modulation (VM) OFF/ON test
41	Re-initialise NVM
43	Select Dual A sound
44	Select Dual B sound
45	Select Mono sound
46	Select Stereo sound
48	Set NVM as non virgin
49	Set NVM as virgin
53	FM Overmodulation Enable/Disable
55	Tuner selection (SONY/ALPS)
59	Select Model 3 Scarts + PIP or 2 Scarts
68	Enable/Disable X26 countermeasure (N problem)
73	Enable Zweiton D/K2 system (6.5/6.74)
74	Enable Zweiton D/K3 system (6.5/5.74)
78	Balance full right
79	Balance full left
87	Local keys test
99	Display Error and Working Time menu

5-1. BLOCK DIAGRAMS (1)

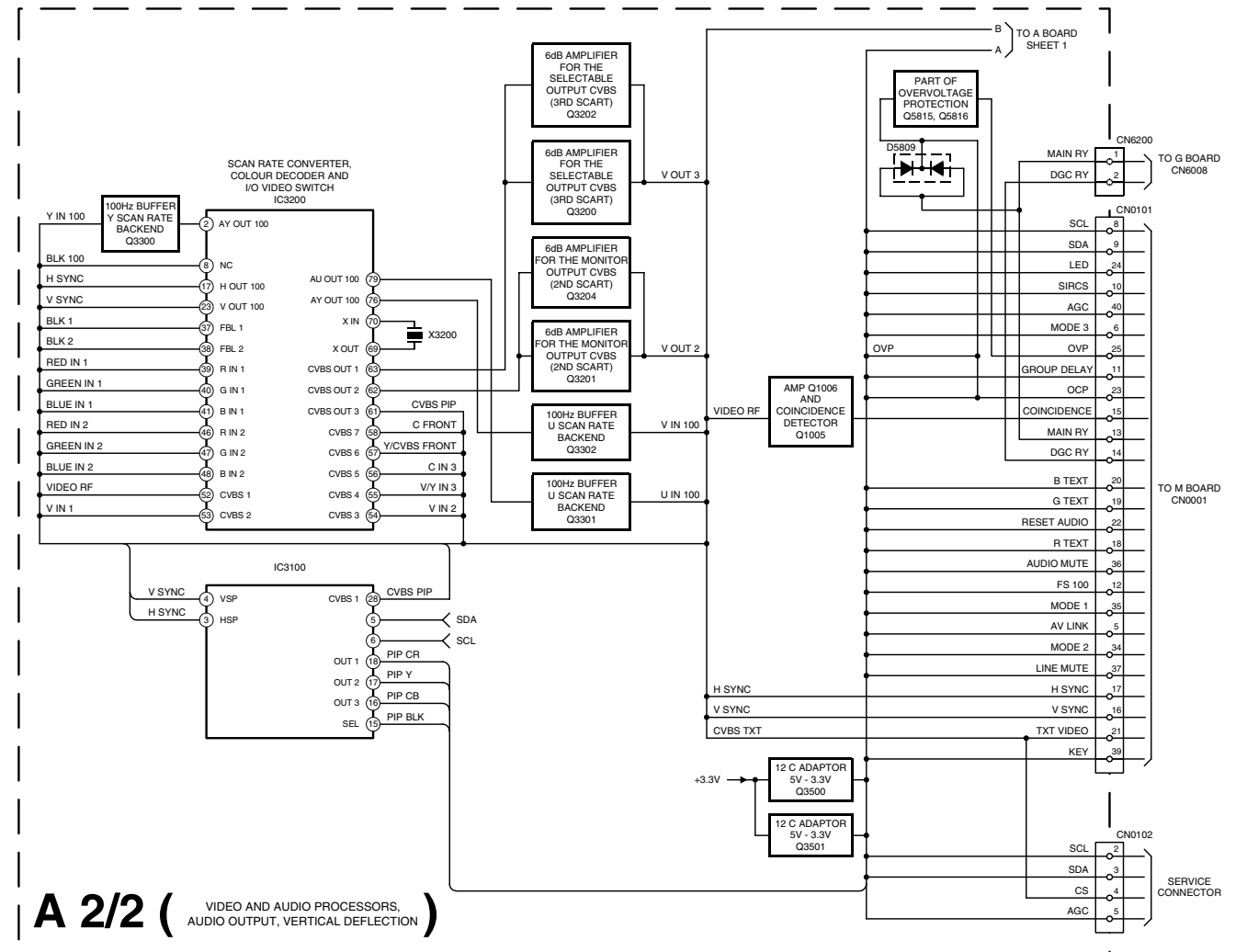
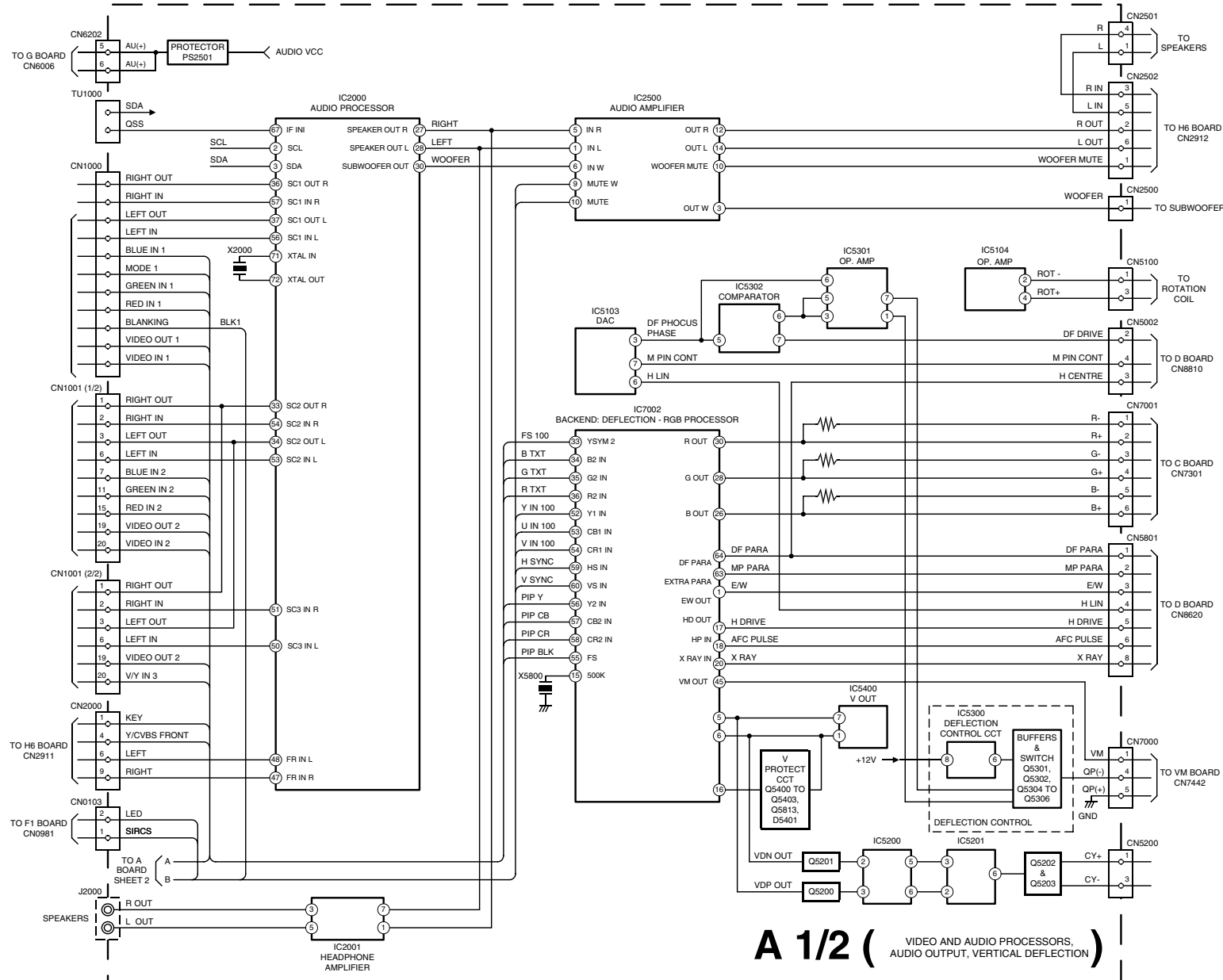
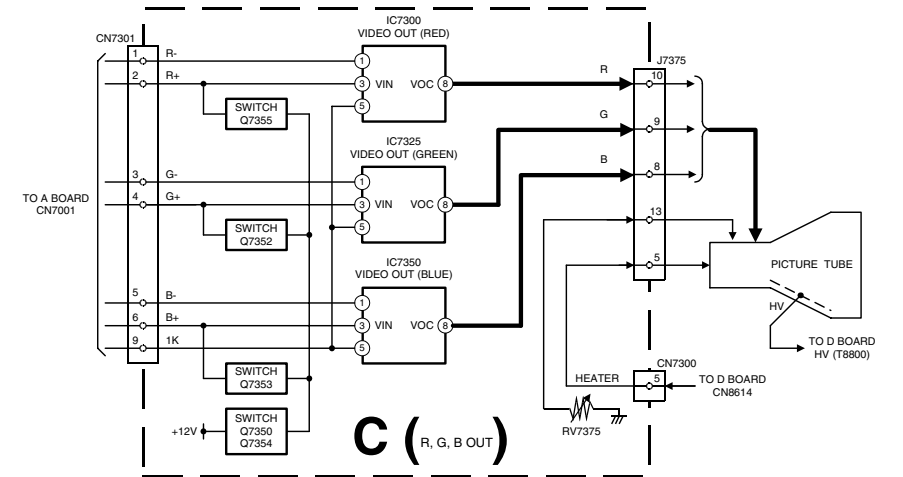
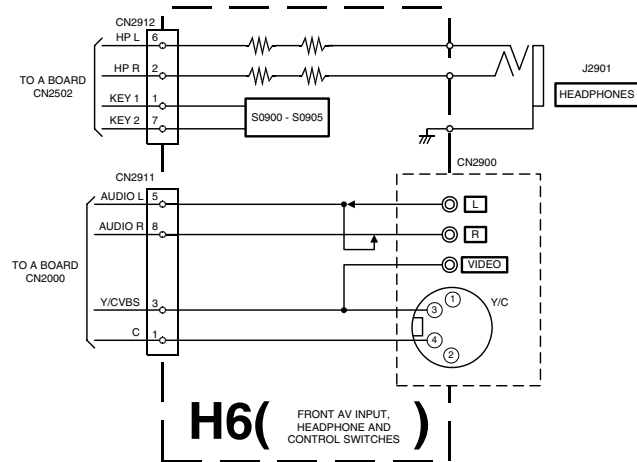
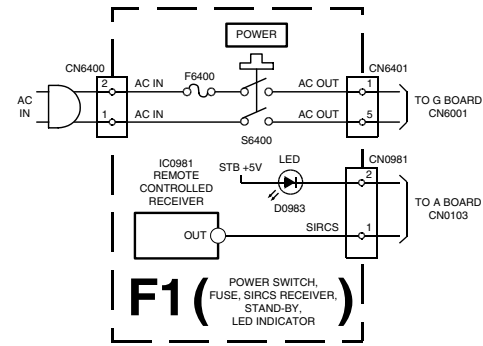

5-1. BLOCK DIAGRAMS (2)

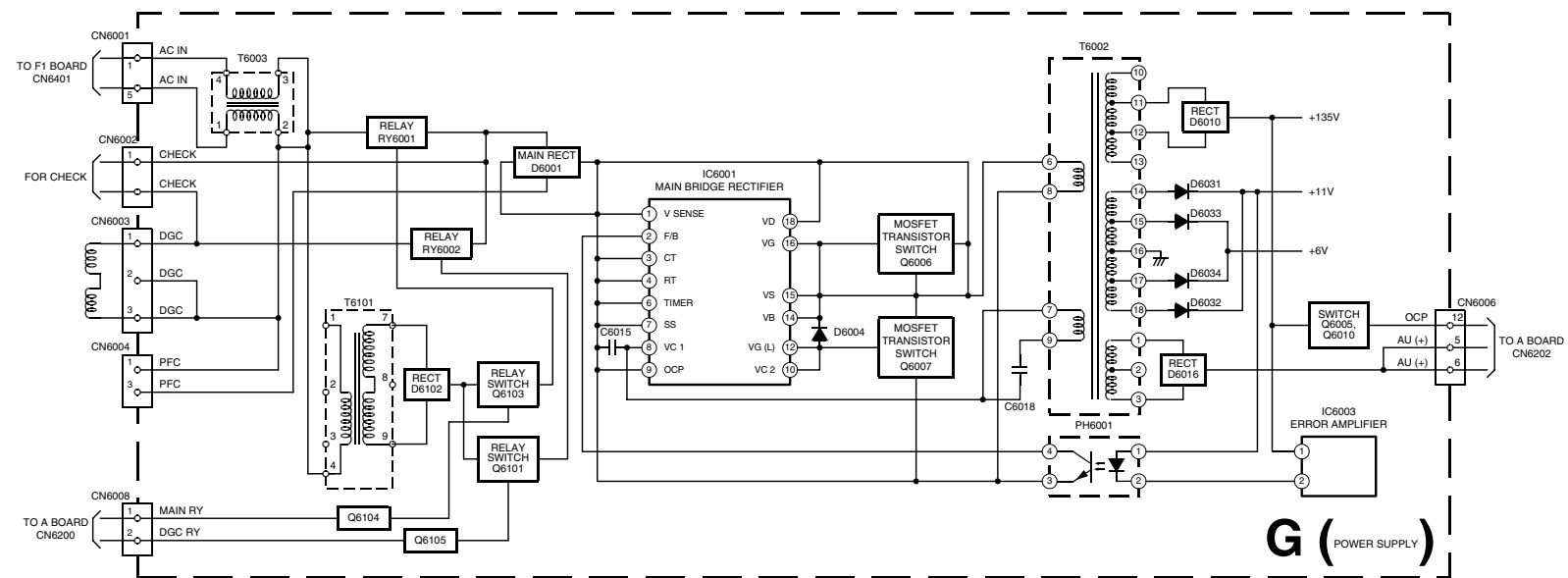
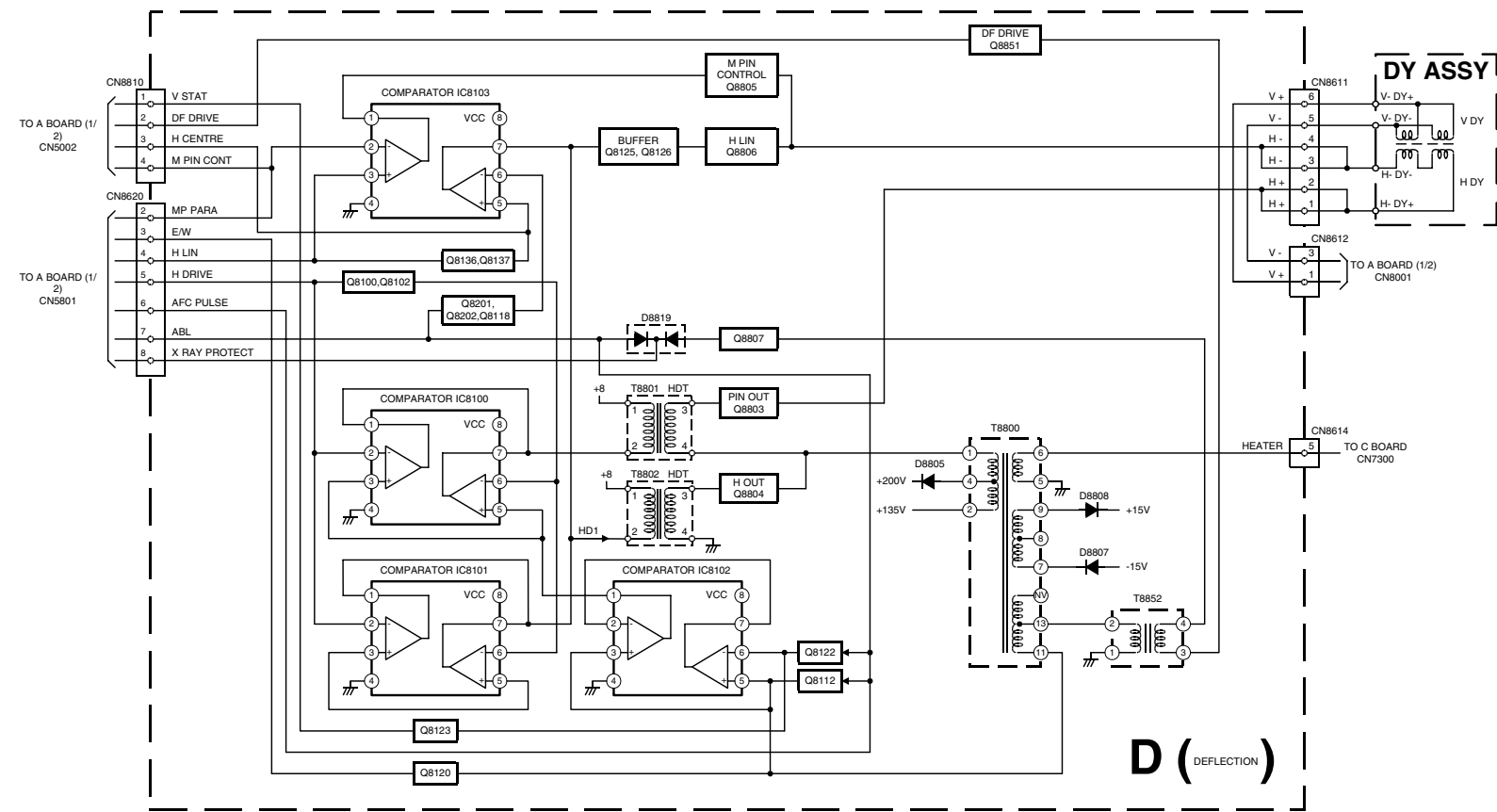

5-1. BLOCK DIAGRAMS (3)

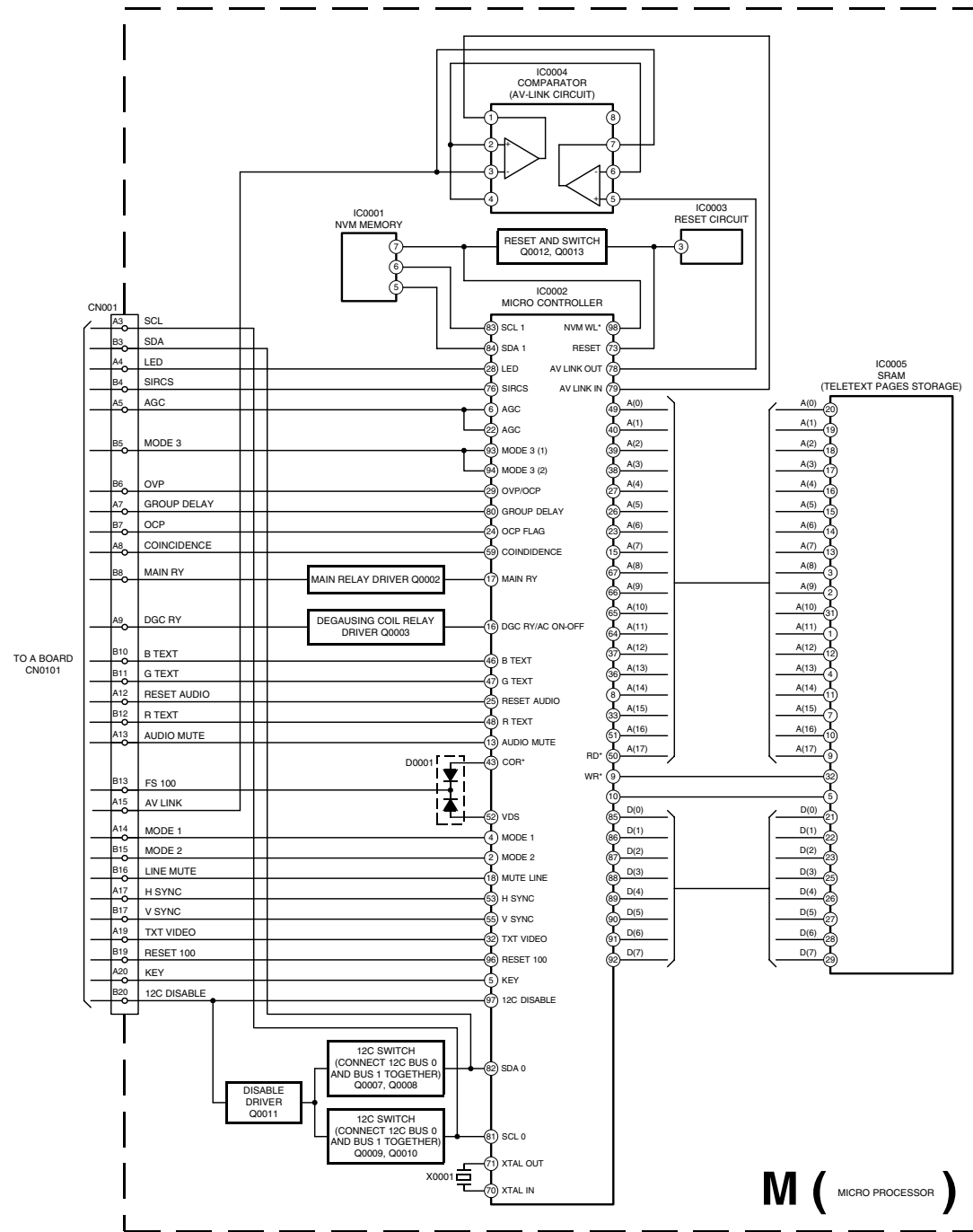

5-2. CIRCUIT BOARD LOCATION

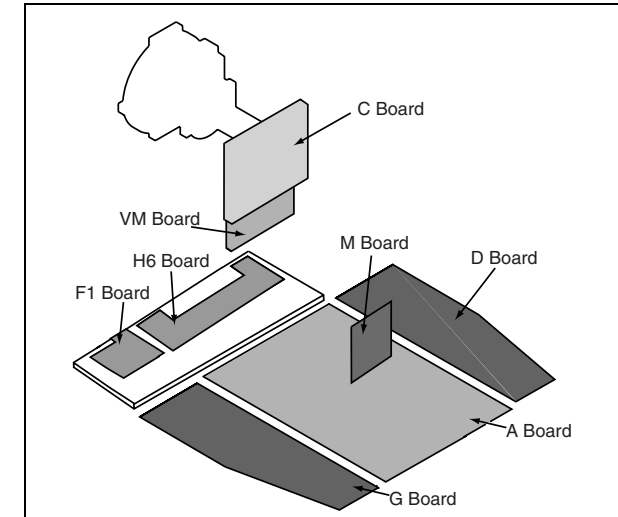

5-3. SCHEMATIC DIAGRAMS AND PRINTED WIRING BOARDS

Note :

- All capacitors are in μF unless otherwise noted.
- $\text{pF} : \mu\text{F} 50\text{WV}$ or less are not indicated except for electrolytic types.
- Indication of resistance, which does not have one for rating electrical power, is as follows.

Pitch : 5mm
Electrical power rating : 1/4W

- Chip resistors are 1/10W
- All resistors are in ohms.
 $k = 1000 \text{ ohms}, M = 1000,000 \text{ ohms}$
- : nonflammable resistor.
- : fusible resistor.
- : internal component.
- : panel designation or adjustment for repair.
- All variable and adjustable resistors have characteristic curve B, unless otherwise noted.
- All voltages are in Volts.
- Readings are taken with a 10Mohm digital mutimeter.
- Readings are taken with a color bar input signal.
- Voltage variations may be noted due to normal production tolerances.
- : B + bus.
- : B - bus.
- : RF signal path.
- : earth - ground.
- : earth - chassis.

Reference Information

RESISTOR	RN	: METAL FILM
	RC	: SOLID
	FPRD	: NON FLAMMABLE CARBON
	FUSE	: NON FLAMMABLE FUSIBLE
	RS	: NON FLAMMABLE METAL OXIDE
	RB	: NON FLAMMABLE CEMENT
	RW	: NON FLAMMABLE WIREWOUND
		: ADJUSTMENT RESISTOR
COIL	LF-8L	: MICRO INDUCTOR
CAPACITOR	TA	: TANTALUM
	PS	: STYROL
	PP	: POLYPROPYLENE
	PT	: MYLAR
	MPS	: METALIZED POLYESTER
	MPP	: METALIZED POLYPROPYLENE
	ALB	: BIPOLAR
	ALT	: HIGH TEMPERATURE
	ALR	: HIGH RIPPLE

Note : The components identified by shading and marked Δ are critical for safety. Replace only with the part numbers specified in the parts list.

Note : Les composants identifiés par une trame et par une marque Δ sont d'une importance critique pour la sécurité. Ne les remplacer que par des pièces de numéro spécifié.

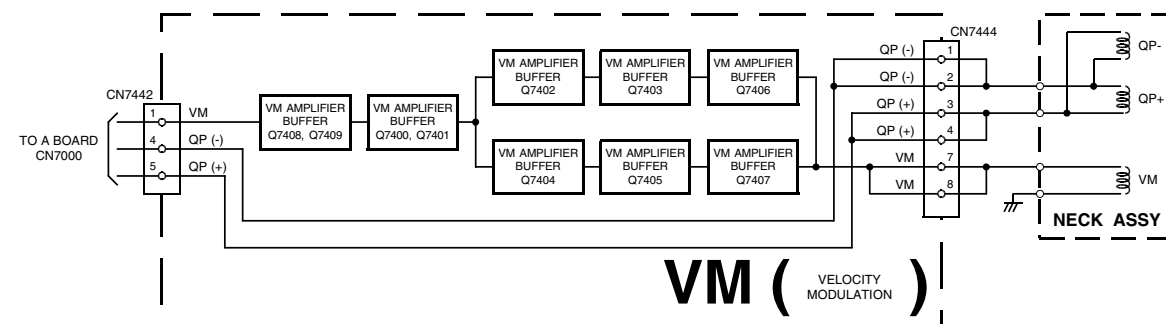

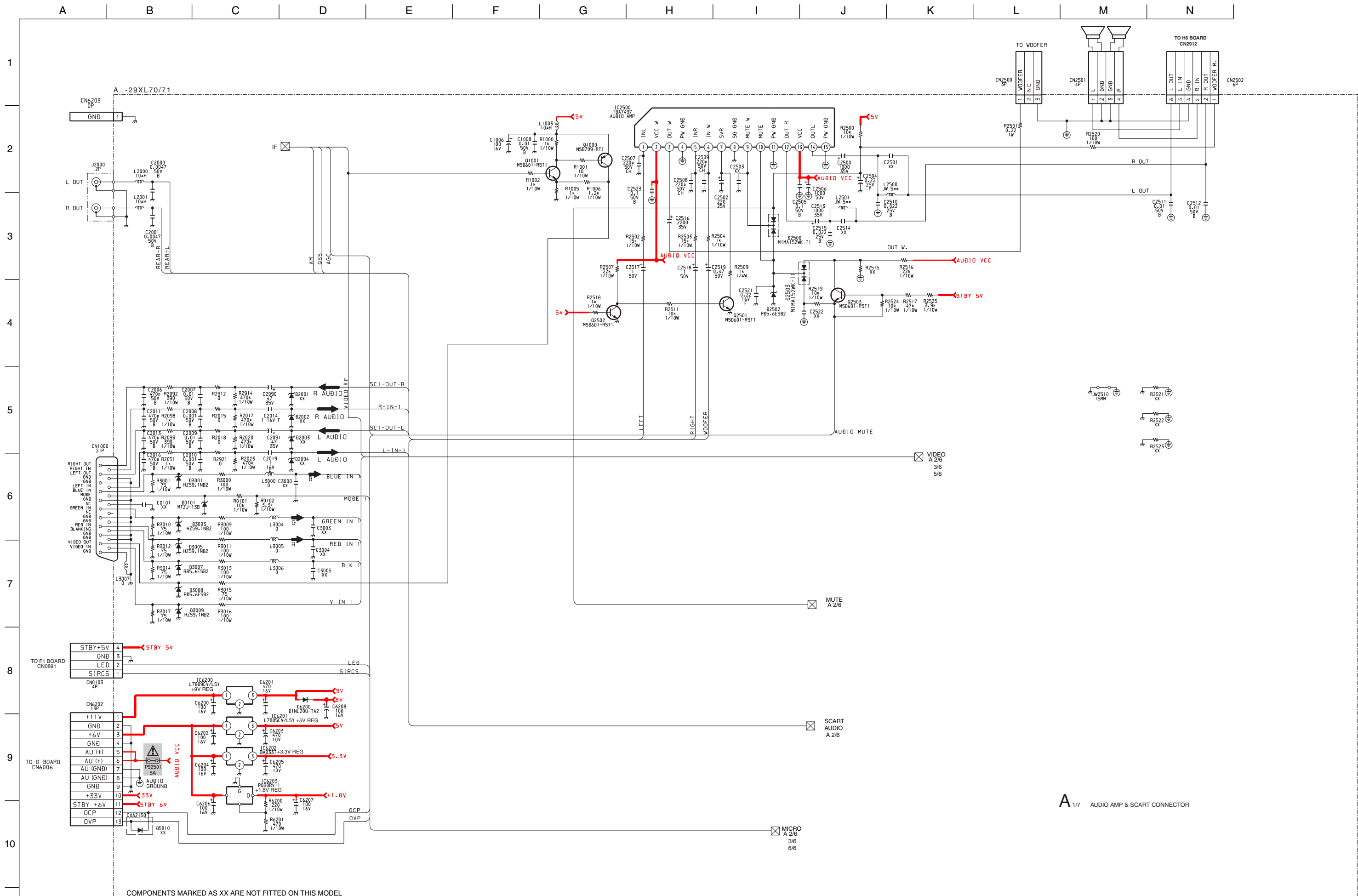

A_{1/7} AUDIO AMP & SCART CONNECTOR

A.-29XL70/71

COMPONENTS MARKED AS XX ARE NOT FITTED ON THIS MODEL

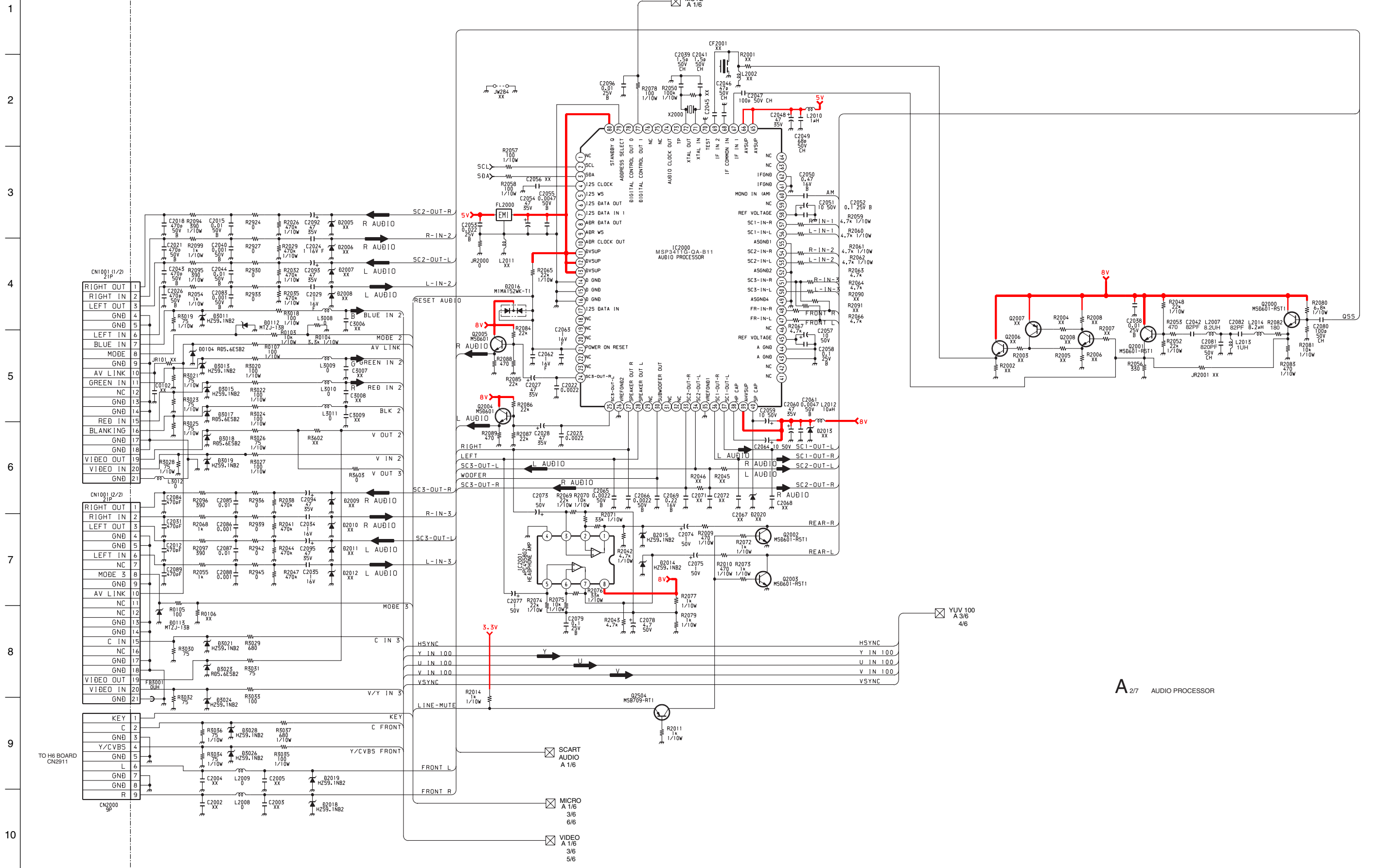

A 2/7 AUDIO PROCESSOR

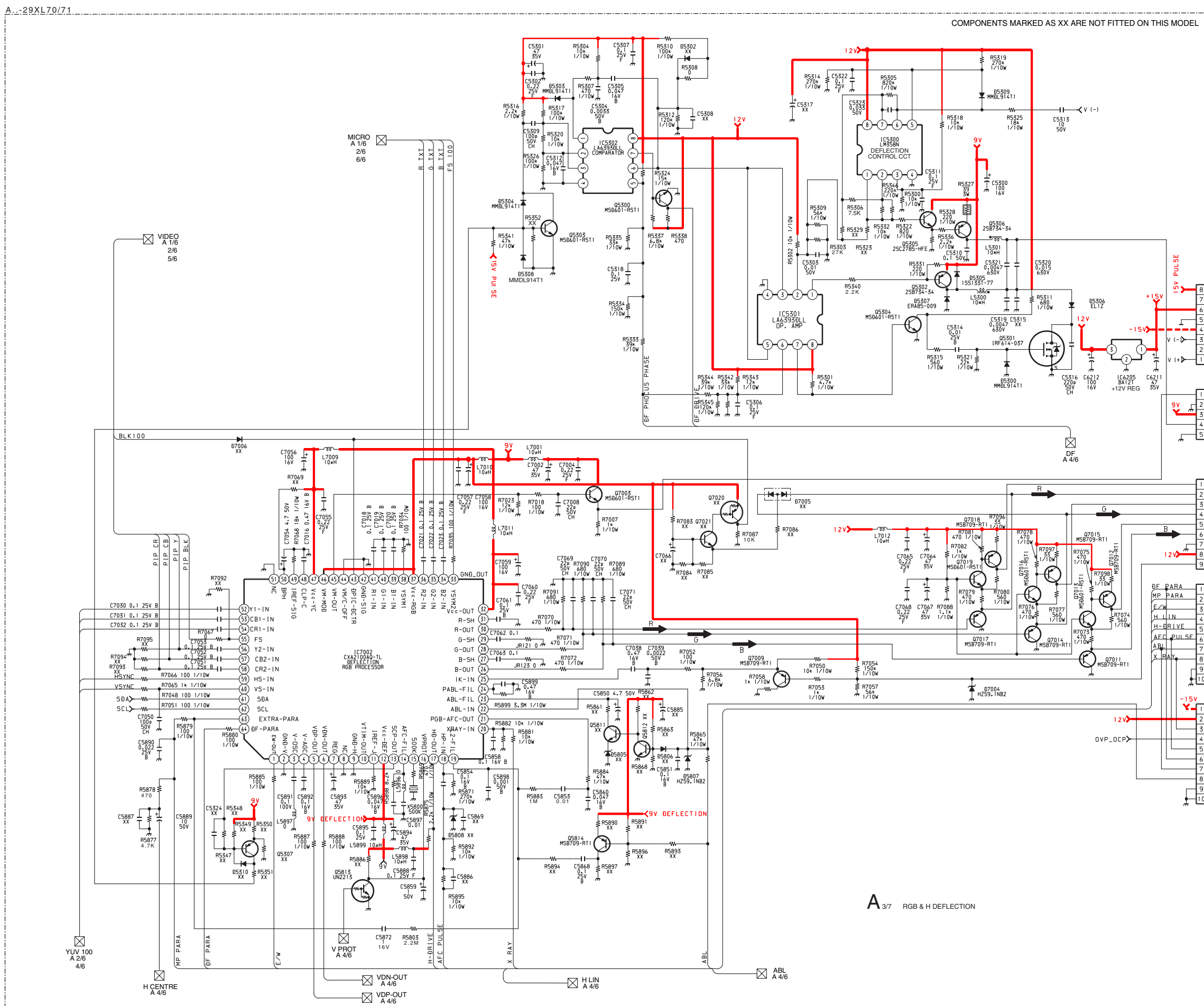

A 3/7 RGB & H DEFLECTION

1

2

3

4

5

6

7

8

9

10

11

A...29XL70/71

A_{4/7} VERTICAL DEFLECTION & ROTATION COIL

COMPONENTS MARKED AS XX ARE NOT FITTED ON THIS MODEL

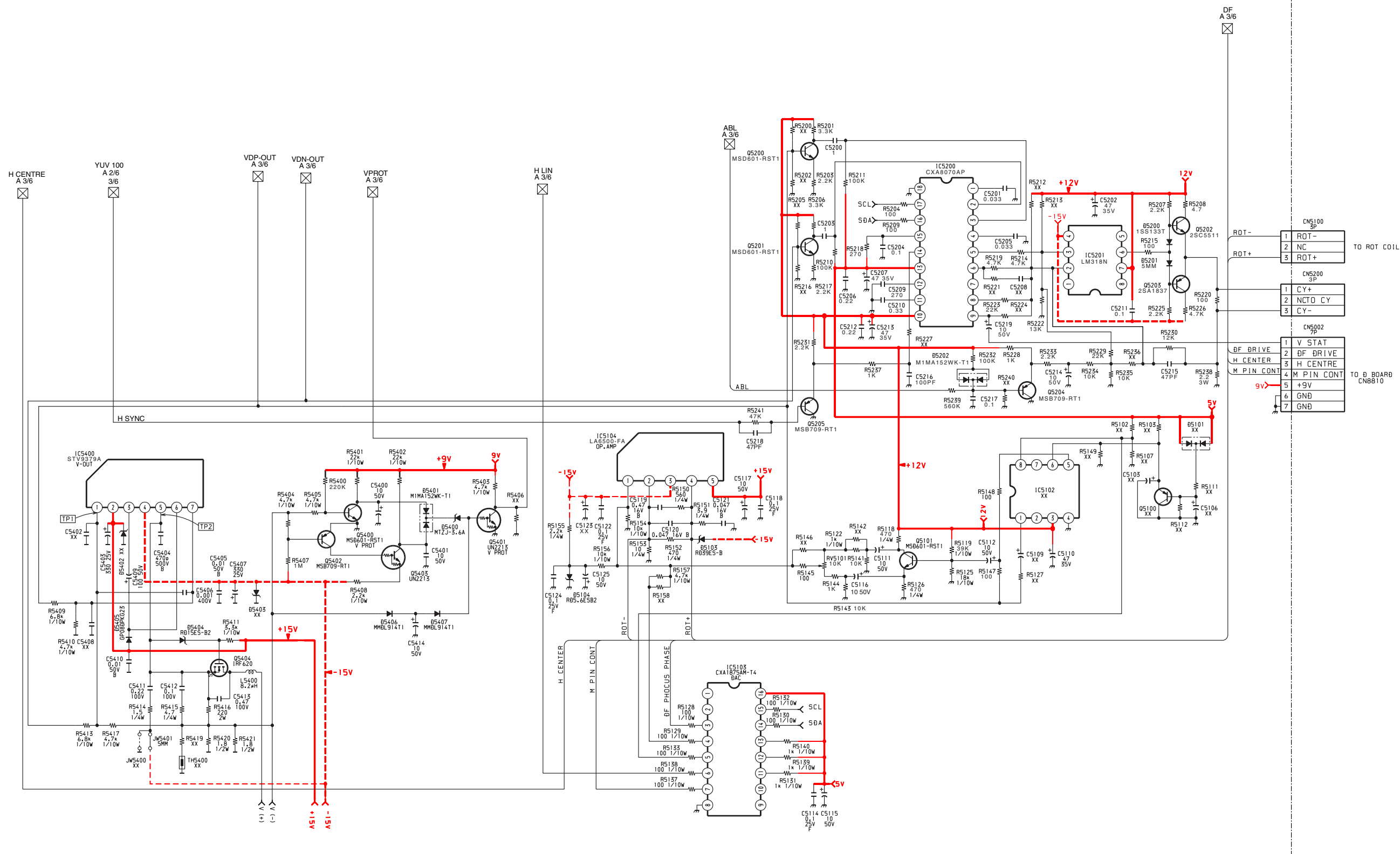

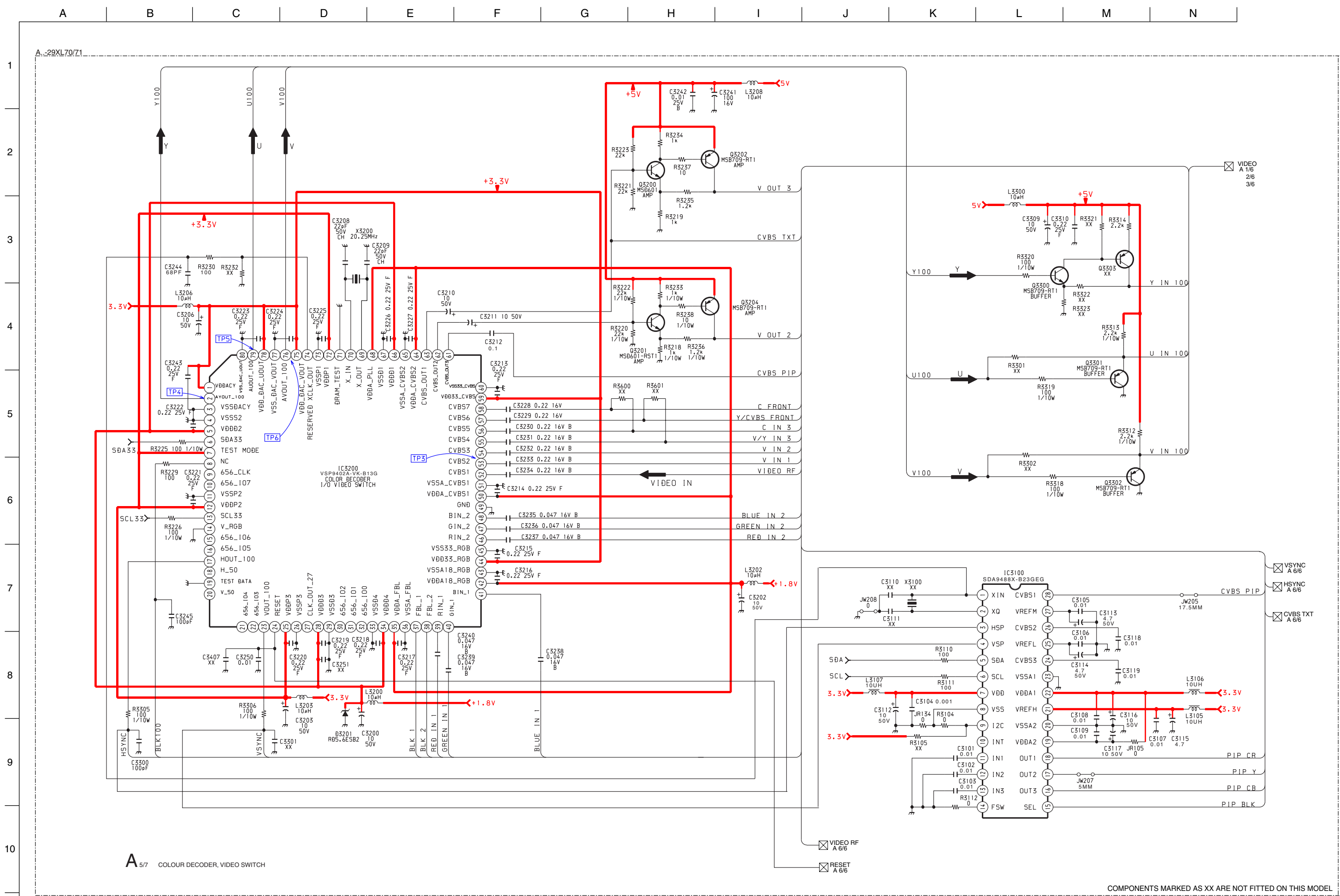

A_{5/7} COLOUR DECODER, VIDEO SWITCH

COMPONENTS MARKED AS XX ARE NOT FITTED ON THIS MODEL

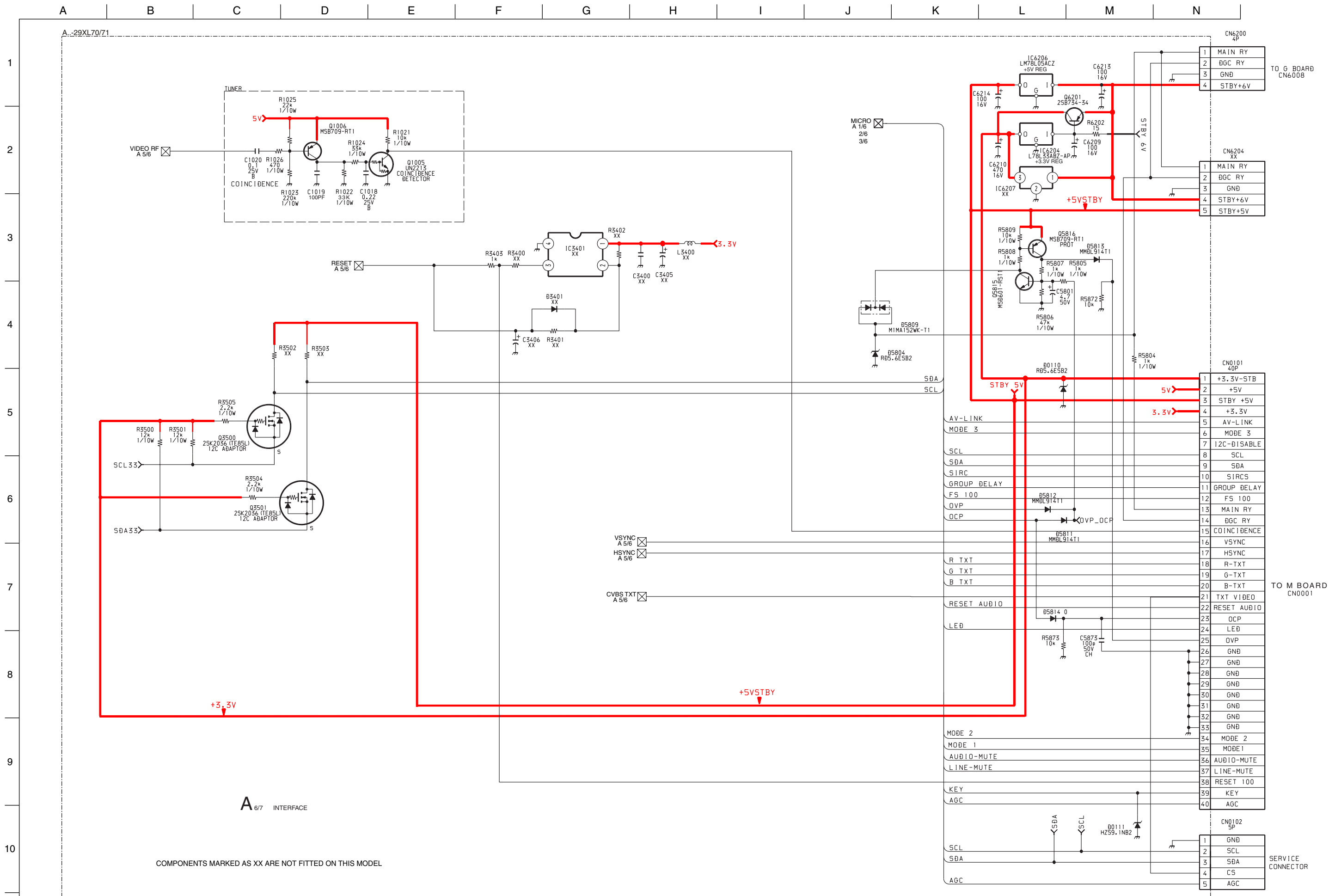

COMPONENTS MARKED AS XX ARE NOT FITTED ON THIS MODEL

A 6/7 INTERFACE

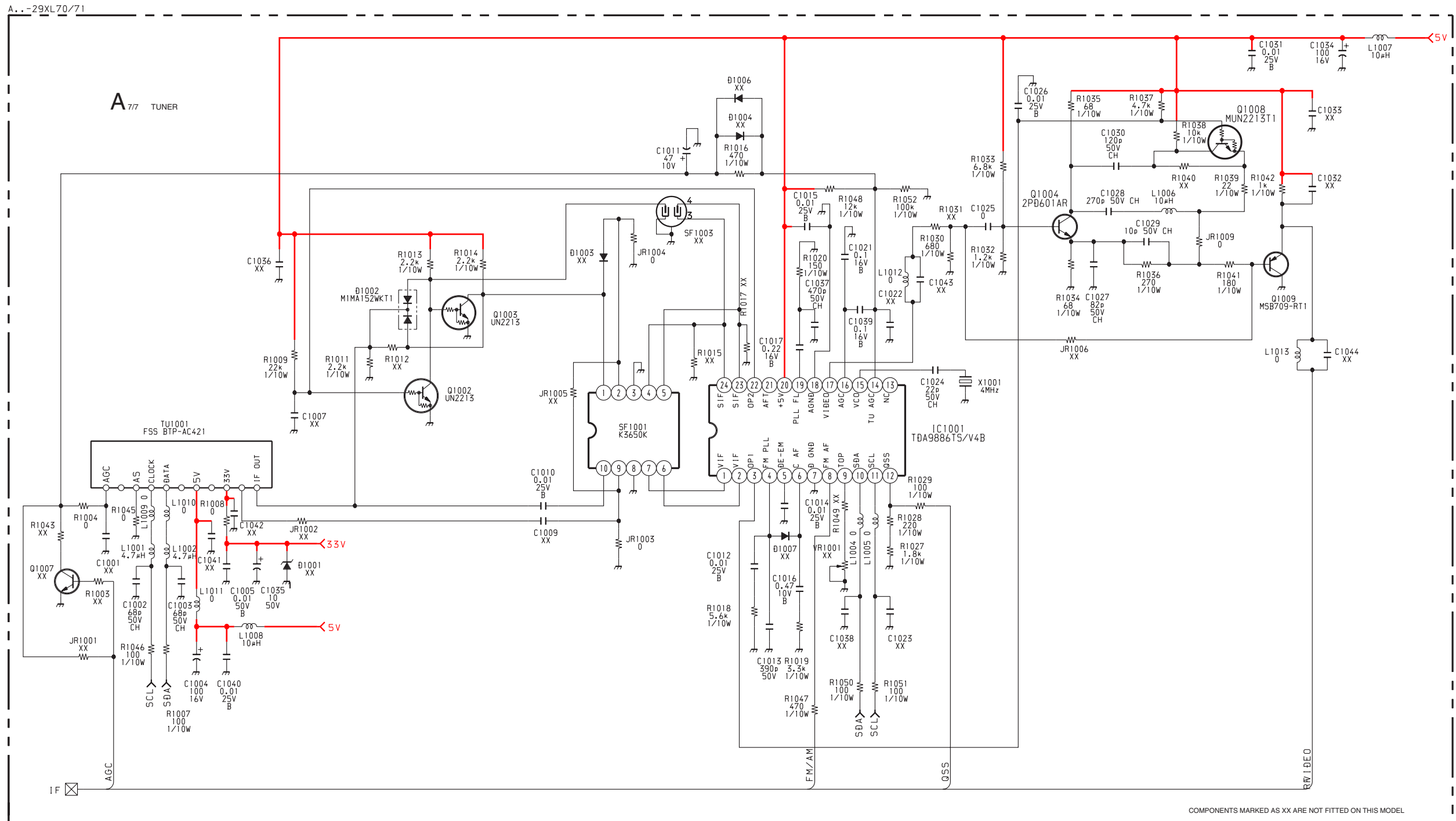

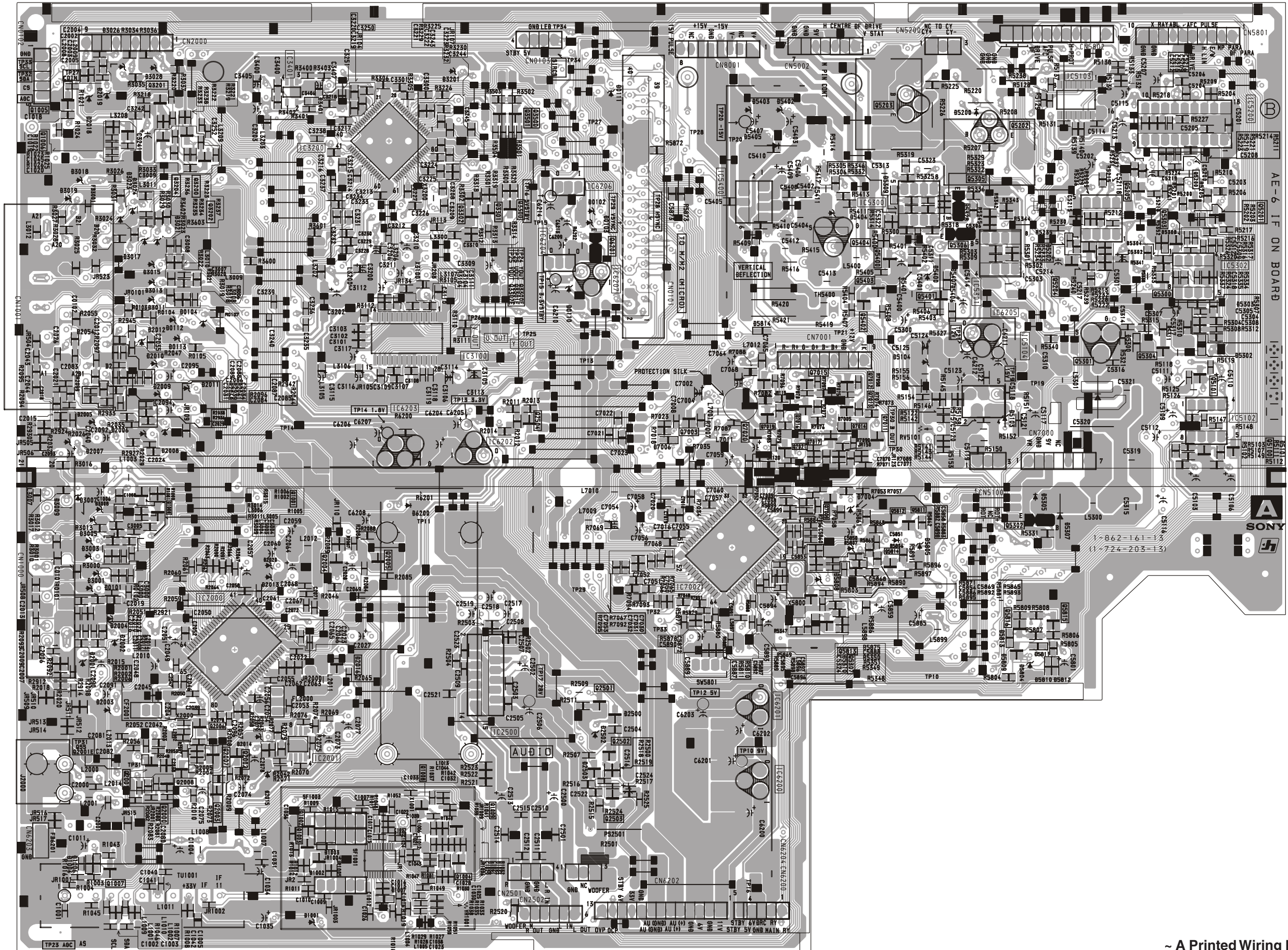

~ A Printed Wiring Board Conductor side B ~

~ A Board IC Voltage Table ~

IC Voltage Table																
Ref No	Pin No	Voltage (V)	Ref No	Pin No	Voltage (V)	Ref No	Pin No	Voltage (V)	Ref No	Pin No	Voltage (V)	Ref No	Pin No	Voltage (V)		
IC3100	1	1.3	IC5103	6	1.8	IC5201	5	9.3	IC7002	6	13.7	IC7002	32	8.9		
	2	1.7		7	2		IC5201	6		0.5	7		1.4	33	0	
	3	2.6		8	0		IC5201	7		12.1	8		-14.1	34	4.7	
	4	0		9	3.1		IC5201	8		0	9		0	35	4.7	
	5	2.5		10	3		IC5300	1		6	10		0.4	36	4.7	
	6	3.3		11	5			IC5300		2	6		11	1.8	37	8.9
	7	0		12	5			IC5300		3	6		12	0	38	0
	8	0		13	5			IC5300		4	0		13	0.4	39	4.8
	9	1.1		14	0	IC5300		5		6	14		0.9	40	4.8	
	10	1.1		15	0	IC5300		6		6	15		2.5	41	4.8	
	11	0		16	5	IC5300		7		6	16		0	42	0	
	12	0		17	0	IC5300		8		0	17		3	43	0	
	13	0		18	0	IC5301	1	1.7		18	2.7		44	0		
	14	0		19	3.9		IC5301	2		5.8	19		0	45	6.3	
	15	0.5	20	0	IC5301		3	6.3	20	6.1	46	8.9				
	16	0.3	21	6.1	IC5301		4	0	21	2.7	47	8.9				
	17	0.3	22	2.7	IC5301		5	6.6	22	8.8	48	6				
	18	0.3	23	8.8	IC5301		6	6.5	23	0	49	2.5				
	19	3.3	24	0	IC5301		7	0.4	24	0	50	4.1				
	20	0	25	4.3	IC5301		8	12	25	3.2	51	0				
	21	3.3	26	3.2	IC5200	1	0	26	5.2	52	6					
	22	3.3	27	5.2		IC5200	2	5.8	27	0.3	53	5.8				
	23	0	28	0.3		IC5200	3	6.3	28	0.3	54	5.8				
	24	3.2	29	4.9		IC5200	4	0	29	4.9	55	0.4				
	25	1.2	30	3.4		IC5200	5	6.6	30	3.4	56	5.8				
	26	3.2	31	5.6		IC5200	6	6.5	31	5.6	57	5.8				
	27	2.1	32	0		IC5200	7	0.4	32	0	58	5.8				
	28	0.3	33	0		IC5200	8	12	33	0	59	0.3				
IC5103	1	3.3	IC5201	1	9.3	IC5400	1	1.4	34	0						
	2	3.3		IC5201	2		3.8	IC5400	2	13.2	35	0				
	3	1.9		IC5201	3		3.8	IC5400	3	-12.5	36	0				
	4	2.6		IC5201	4		-15.4	IC5400	4	-15.4	37	0				
	5	2.5		IC5201	4		-15.4	IC5400	5	-0.4	38	0				

~ A Board Location Table (A Side) ~

DIODE																	
D0101	M - 7	D2014	K - 9	D3005	M - 7	D3017	M - 4	D3028	M - 2	D5306	C - 5	D7004	F - 7	IC5301	D - 4	IC6206	H - 3
D0104	L - 4	D2018	M - 2	D3008	M - 7	D3018	N - 3	D3201	J - 2	D5307	C - 6	D5809	K - 8	IC5302	B - 4	IC6207	H - 4
D0110	I - 4	D2019	M - 2	D3009	N - 7	D3021	M - 4	D5104	E - 5	D5404	F - 3	IC		IC5400	G - 4	TRANSISTOR	
D0111	H - 2	D2502	H - 9	D3011	M - 4	D3023	M - 4	D5200	D - 2	D5405	F - 3	IC5104	D - 6	IC6201	G - 10	Q5202	E - 2
D0112	M - 4	D3001	M - 7	D3013	M - 4	D3024	M - 4	D5201	E - 2	D5807	F - 7	IC5200	B - 3	IC6202	I - 6	Q5301	C - 5
D0113	M - 5	D3003	M - 7	D3015	M - 4	D3026	M - 2	D5305	D - 6	D6200	J - 6	IC5201	C - 4	IC6203	J - 6	Q5306	E - 4
D1006	M - 10											IC5300	E - 4	IC6205	D - 5	Q5404	F - 4

~ A Board Location Table (B Side) ~

DIODE																	
D0101	B - 7	D3001	B - 7	D3026	B - 2	D5309	J - 3	IC5103	L - 3	TRANSISTOR		Q3201	C - 2	Q5300	M - 4	Q7003	H - 6
D0104	C - 5	D3003	B - 7	D3028	C - 2	D5400	K - 4	IC5104	K - 6	Q1000	C - 6	Q3202	C - 3	Q5301	L - 5	Q7009	K - 6
D0110	G - 4	D3005	B - 7	D3201	F - 2	D5404	J - 3	IC5200	M - 3	Q1001	D - 6	Q3204	C - 3	Q5302	K - 7	Q7011	J - 6
D0111	G - 2	D3007	B - 6	D5103	L - 6	D5405	I - 3	IC5300	J - 3	Q1004	D - 10	Q3300	F - 3	Q5303	M - 4	Q7012	J - 5
D0112	C - 5	D3008	B - 6	D5104	J - 5	D5809	K - 8	IC5301	K - 4	Q1005	B - 2	Q3301	F - 3	Q5304	M - 5	Q7013	J - 6
D0113	C - 5	D3009	B - 6	D5200	K - 2	D5811	L - 8	IC5302	M - 4	Q1006	B - 3	Q3302	F - 3	Q5305	K - 3	Q7014	J - 6
D1006	B - 10	D3011	C - 4	D5202	L - 4	D5812	L - 8	IC5400	I - 3	Q2000	C - 9	Q3500	F - 3	Q5306	K - 4	Q7015	I - 5
D2014	C - 9	D3013	C - 4	D5300	L - 5	D6200	F - 7	IC6200	I - 9	Q2002	D - 9	Q3501	F - 3	Q5400	J - 4	Q7016	I - 5
D2015	D - 9	D3015	C - 4	D5303	N - 4	IC		IC6201	I - 8	Q2004	E - 7	Q5101	M - 5	Q5401	K - 4	Q7017	I - 6
D2016	E - 8	D3017	B - 4	D5304	M - 4	IC2000	C - 8	IC6202	F - 6	Q2005	E - 7	Q5200	M - 4	Q5402	J - 5	Q7018	I - 5
D2018	B - 2	D3018	B - 3	D5305	L - 6	IC2001	D - 9	IC6203	E - 6	Q2501	G - 8	Q5201	N - 3	Q5403	J - 4	Q7019	I - 5
D2019	B - 2	D3019	B - 3	D5306	L - 5	IC2500	F - 8	IC6205	K - 5	Q2502	G - 9	Q5202	K - 3	Q5404	J - 4		
D2500	G - 9	D3021	C - 4	D5307	L - 7	IC3100	E - 5	IC6206	G - 3	Q2503	G - 9	Q5203	J - 2	Q5813	J - 8		
D2502	G - 9	D3023	B - 3	D5308	M - 4	IC3200	E - 3	IC6207	G - 4	Q2504	G - 9	Q5204	L - 4	Q5815	L - 8		
										Q2505	M - 3	Q5205	M - 3	Q5816	L - 8		

~ A Board Semiconductor Voltage Table ~

Ref	(s)	(g)	(d)	Ref	(e)	(b)	(c)	Ref	(e)	(b)	(c)	Ref	(e)	(b)	(c)	Ref	(e)	(b)	(c)	Ref	(e)	(b)	(c)
Q3500	2.7	3.3	3.9	Q2002	0	0	4	Q3204	5	4.4	3.4	Q5205	1.9	1.2	0	Q5813	0	7.9	0	Q7015	11.6	10.9	8.8
Q3501	2.7	3.3	4	Q2003	0	0	4	Q3300	0.7	1.3	5	Q5300	0	0.4	2.2	Q5814	0	0	0	Q7016	6	6.6	10.9
Q5301	0	5.1	51.2	Q2004	3.3	3.9	8.3	Q3301	1.9	1.2	0	Q5301	5.1	0	51.2	Q5815	0	0	5	Q7017	2.7	2	0
Q5404	0	0	0.5	Q2005	3.3	3.9	8.3	Q3302	1.9	1.2	0	Q5302	8.9	5.7	0	Q5816	5	5	0	Q7018	11.6	10.9	8.6
Ref	(e)	(b)	(c)	Q2501	0	0	15.2	Q3500	3.3	2.7	3.9	Q5304	0	0.4	5.6	Q7003	5.6	6.2	8.8	Q7019	6	6.6	10.9
Q1001	3.2	3.9	8.3	Q2502	0	0.7	0	Q3501	3.3	2.7	4	Q3400	0	0	0.1	Q7009	3.2	7	0.1	Q7020	8.9	8.9	0
Q1004	1.9	1.3	0	Q2503	0.6	0.6	0.5	Q5101	0	0.4	6.4	Q5401	0	0	7.9	Q7011	2.5	1.9	0	Q7021	2.7	2.7	8.9
Q1005	0	0.5	5	Q3200	1.9	2.5	4.4	Q5201	2.8	3.4	7.9	Q5402	0	0	-11.3	Q7012	11.6	10.9	8.7				
Q1006	5	4.7	1	Q3201	1.9	2.5	4.4	Q5202	0.2	0.8	11.7	Q5403	-13.5	-11.2	-8.3	Q7013	6	6.6	10.9				
Q2000	4.2	4.8	8.3	Q3202	5	4.4	3.4	Q5203	0.2	0.8	11.7	Q5404	0	0	0.5	Q7014	2.5	1.8	0				

~ A Board Waveforms ~

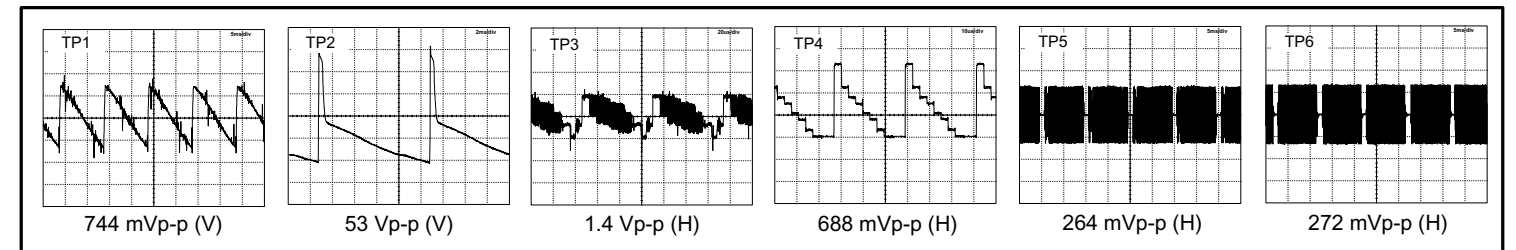

~ VM Printed Wiring Board Conductor side ~

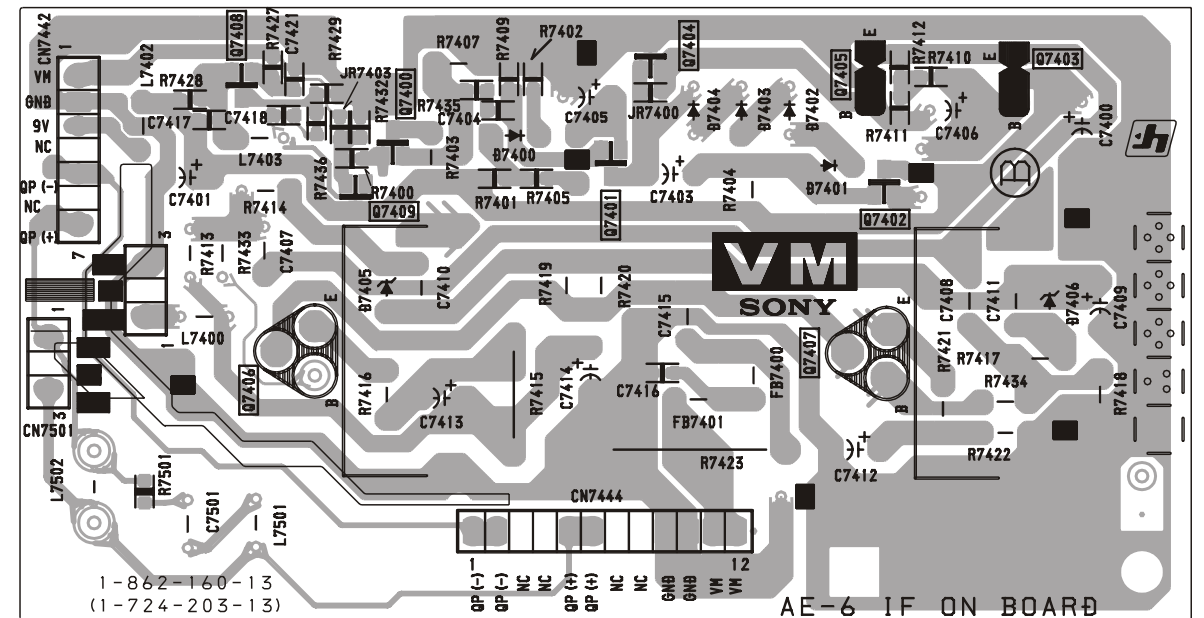

A B C D E F G H I J K L M N

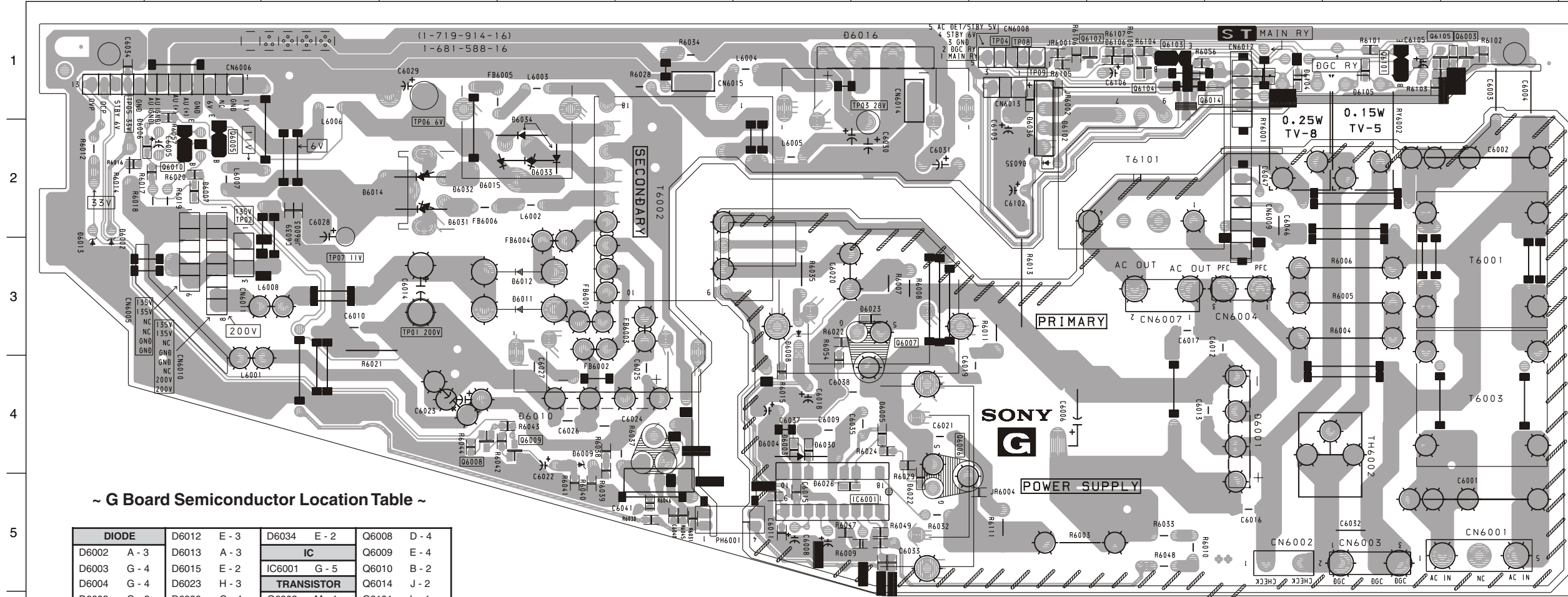

~ G Board Semiconductor Location Table ~

DIODE	D6012	E - 3	D6034	E - 2	Q6008	D - 4	
D6002	A - 3	D6013	A - 3	IC	Q6009	E - 4	
D6003	G - 4	D6015	E - 2	IC6001	G - 5	Q6010	B - 2
D6004	G - 4	D6023	H - 3	TRANSISTOR		Q6014	J - 2
D6008	G - 3	D6030	G - 4	Q6003	M - 1	Q6101	L - 1
D6009	E - 4	D6031	D - 2	Q6005	B - 2	Q6102	J - 1
D6010	E - 4	D6032	D - 2	Q6006	H - 4	Q6103	J - 1
D6011	E - 3	D6033	E - 2	Q6007	H - 3	Q6105	L - 1

~ G Printed Wiring Board Conductor side ~

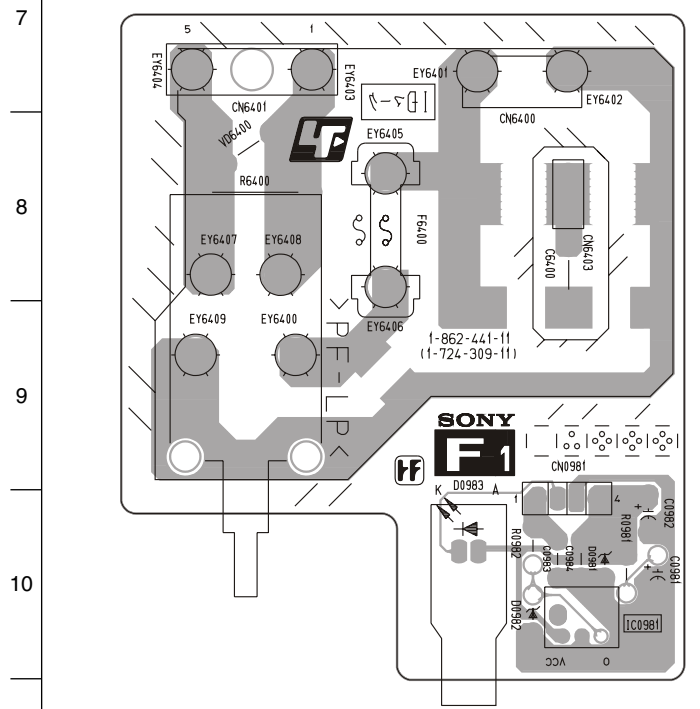

~ F1 Printed Wiring Board Conductor side ~

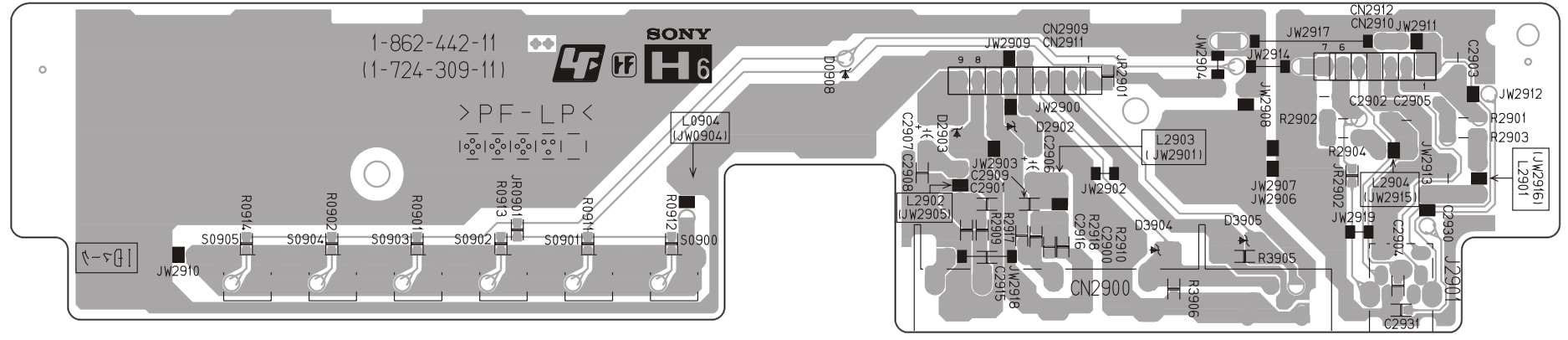

~ H6 Printed Wiring Board Conductor side ~

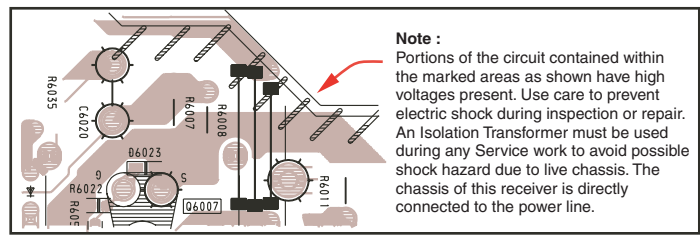

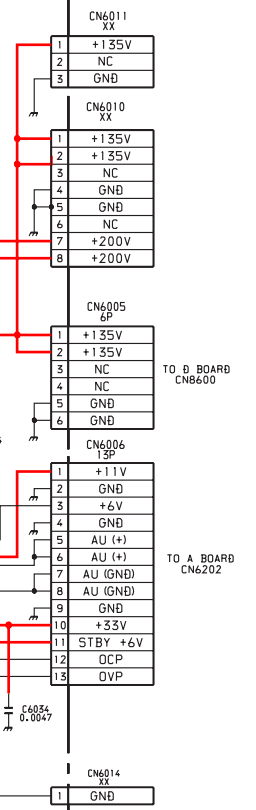
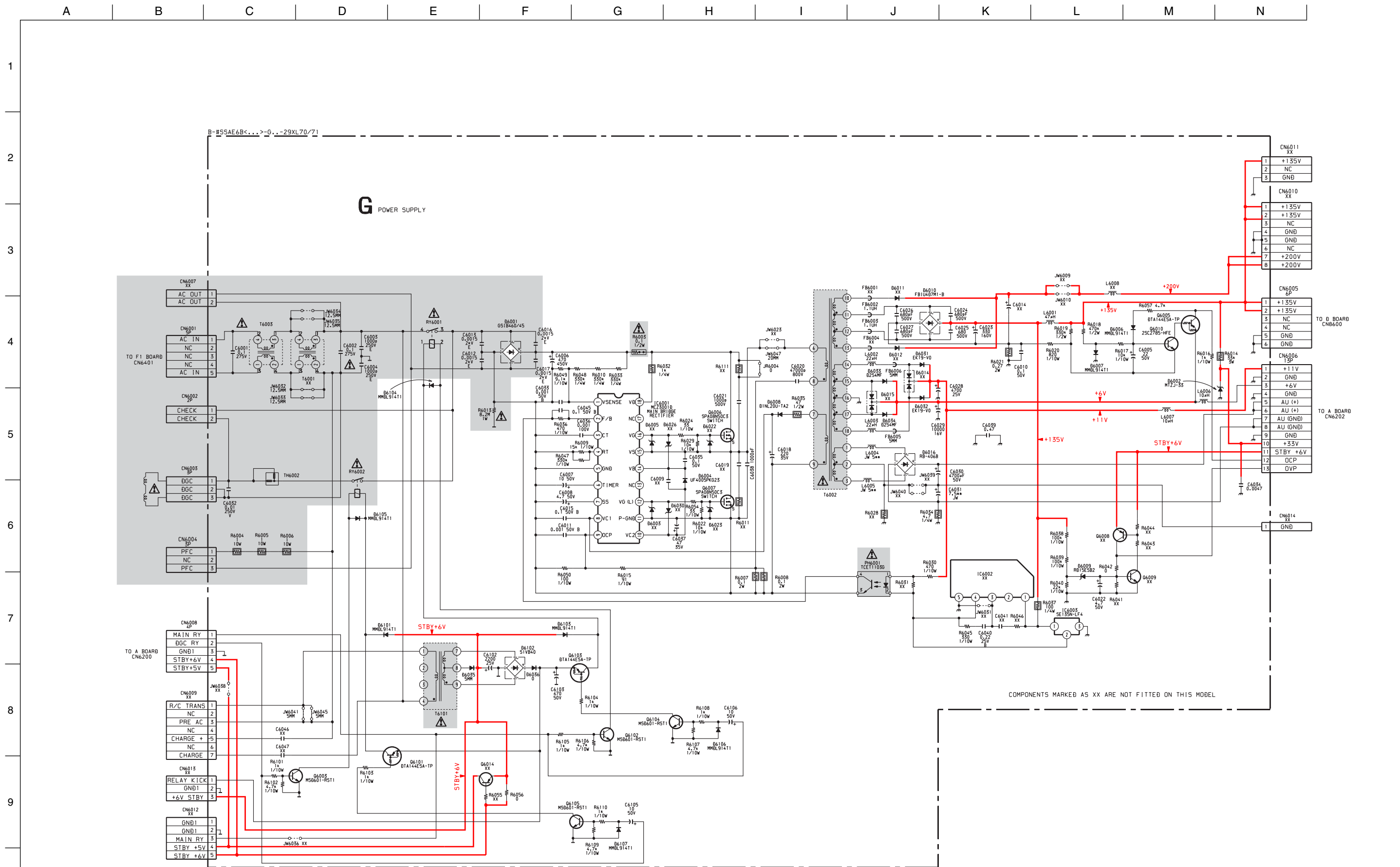

~ G Board Schematic Diagram [Power Supply] ~

~ D Printed Wiring Board Conductor side ~

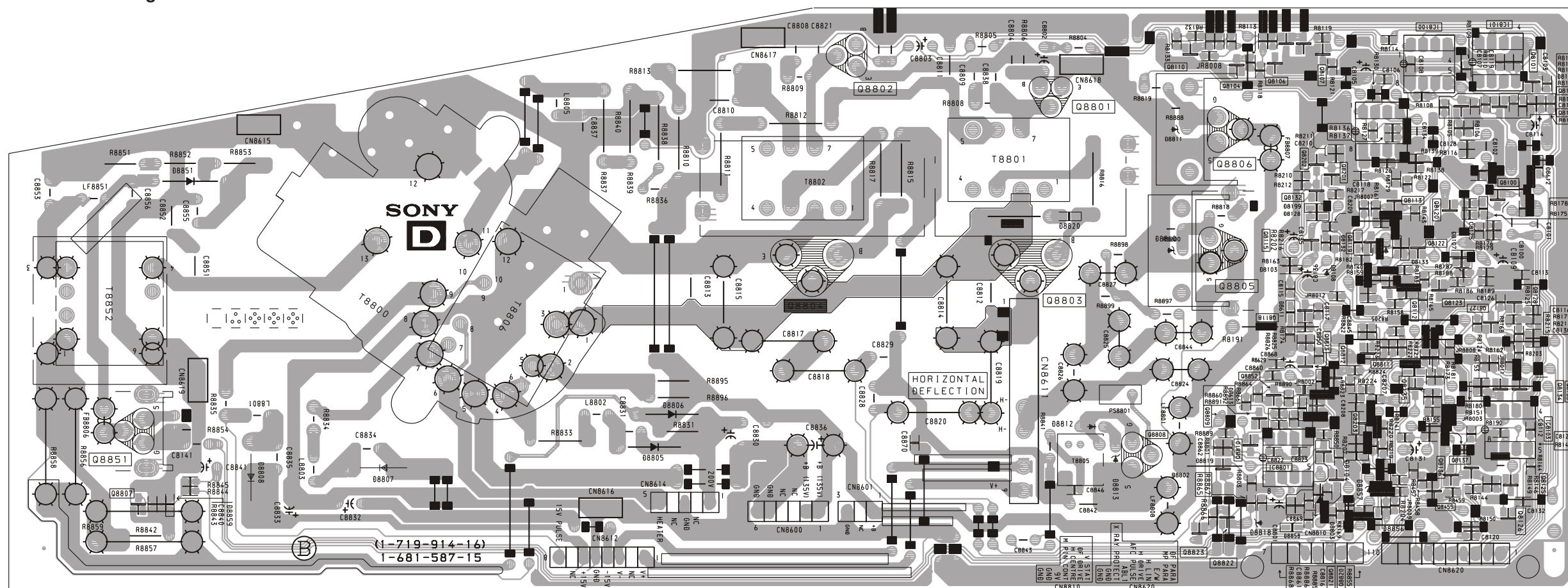

~ D Board Waveforms ~

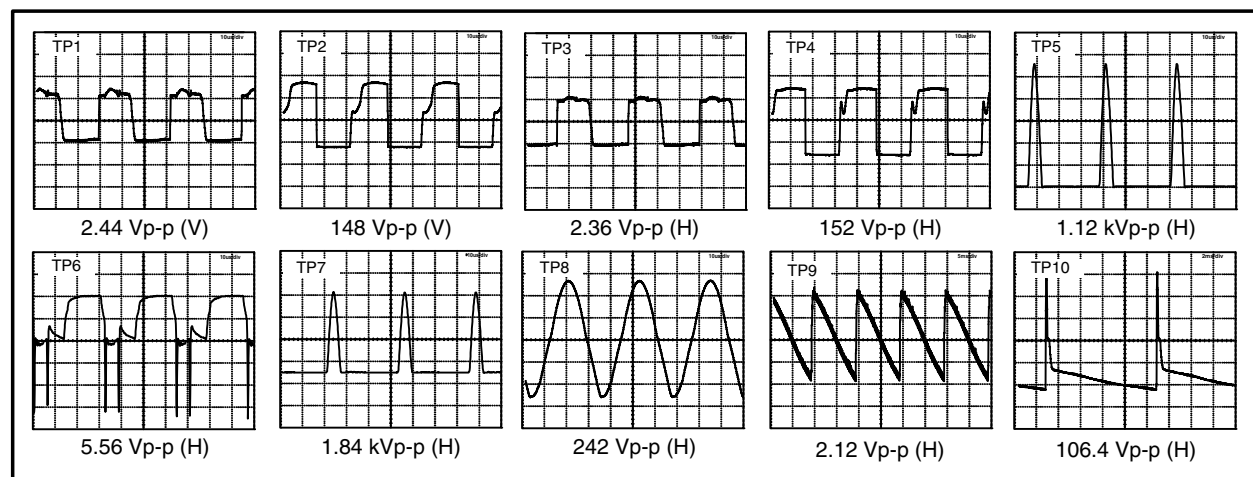

~ D Board IC Voltage Table ~

IC Voltage Table		
Ref No	Pin No	Voltage (V)
IC8100	1	0.3
	2	4.3
	3	4.1
	5	4.1
	6	3.0
	7	0.4
	IC8101	1
2		4.3
3		4.4
5		4.4
6		3.0
7		0.4
IC8102		1
	2	0.4
	3	0.4
	5	0.4
	6	0.4
	7	0.4
	IC8103	1
2		2.1
3		1.7
5		1.6
6		1.0
7		1.1

~ D Board Semiconductor Voltage Table ~

Ref	(e)(s)	(b)(g)	(c)(d)	Ref	(e)(s)	(b)(g)	(c)(d)	Ref	(e)(s)	(b)(g)	(c)(d)	Ref	(e)(s)	(b)(g)	(c)(d)
Q8100	0	0.6	3.6	Q8110	2.4	3.1	0	Q8128	3.4	1.5	8.9	Q8801	0	0.4	64.7
Q8101	0	0.6	4.3	Q8113	0.3	0.2	8.9	Q8132	0	0	3.4	Q8802	0	0.4	73.2
Q8102	0	0.3	4.3	Q8115	8.6	8.9	0	Q8135	2.6	3.2	8.9	Q8807	0	6.3	0
Q8103	4.0	0	8.9	Q8118	0	0	5.0	Q8136	2.5	1.8	0	Q8818	0	0	5.0
Q8104	0	0.4	3.1	Q8119	0.7	1.4	0	Q8137	1.8	2.5	8.9	Q8822	5.5	4.9	0
Q8105	0	0.4	3.2	Q8120	0.7	2.3	0	Q8201	0	0.6	3.9	Q8823	8.9	8.5	0
Q8106	0	0.3	4.3	Q8122	0.5	1.4	0	Q8202	0	0.8	3.4	Q8805	0	2.5	33
Q8107	0	0.3	4.2	Q8123	0.5	1.4	0	Q8203	1.4	0.9	0	Q8806	0	1.2	135
Q8108	2.4	3.2	0	Q8127	1.4	1.5	0	Q8455	1.1	1.7	8.9	Q8851	0	5.4	81.5

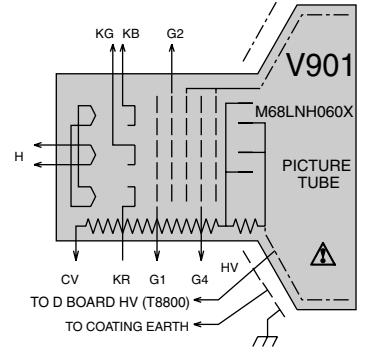
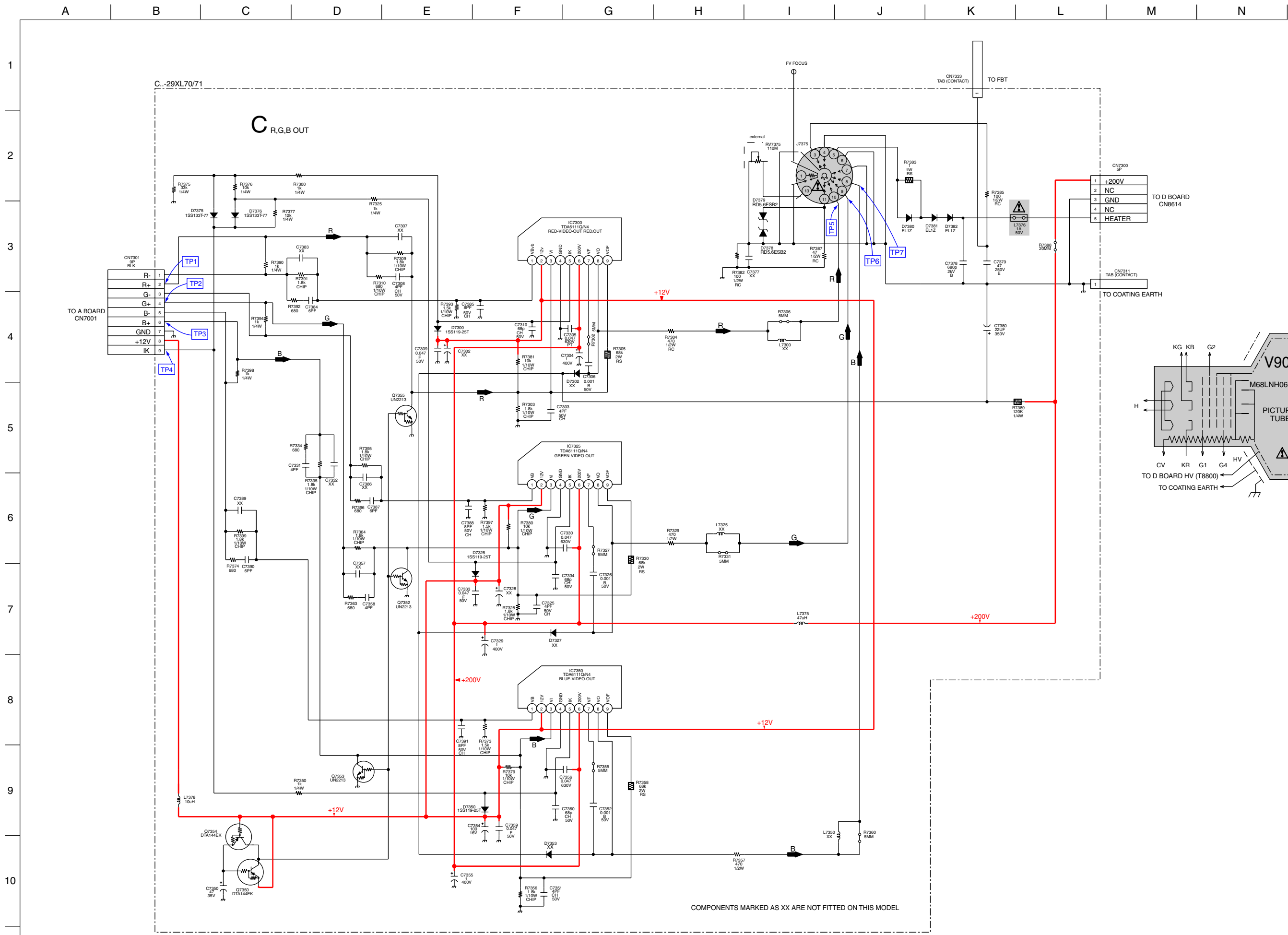

~ C Board Schematic Diagram [R-G-B Out] ~

~ C Printed Wiring Board Conductor side ~

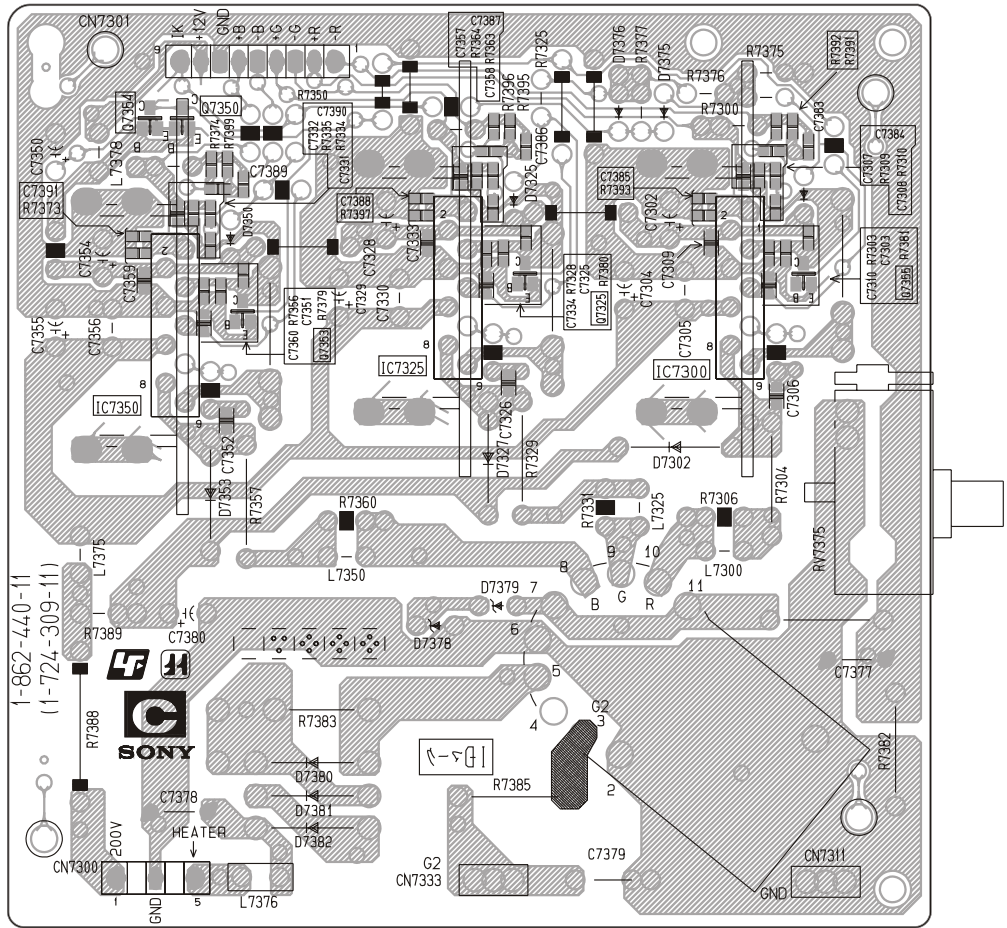

~ M Printed Wiring Board Conductor side A ~

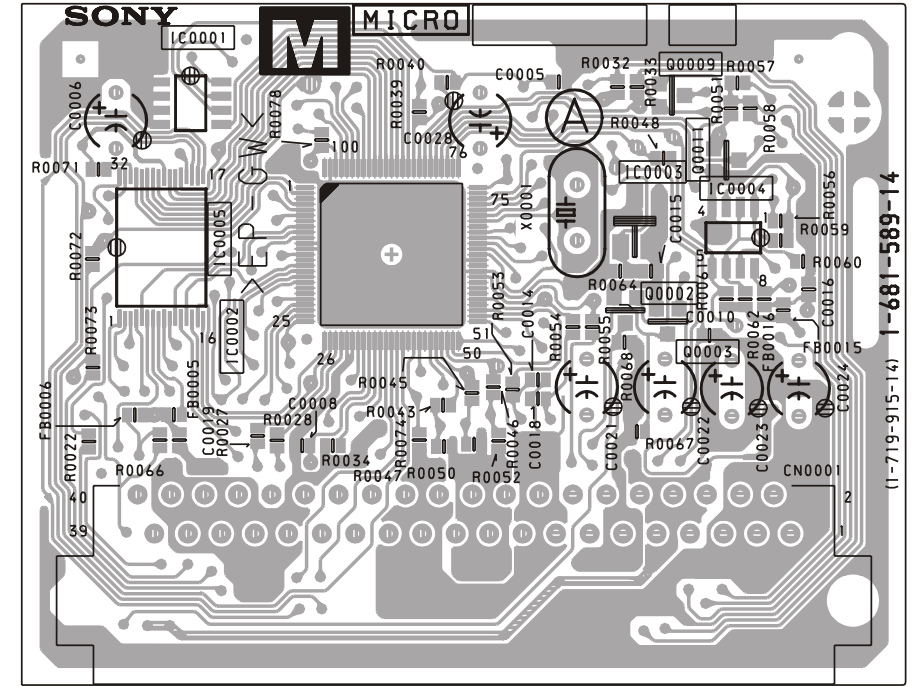

~ C Board Waveforms ~

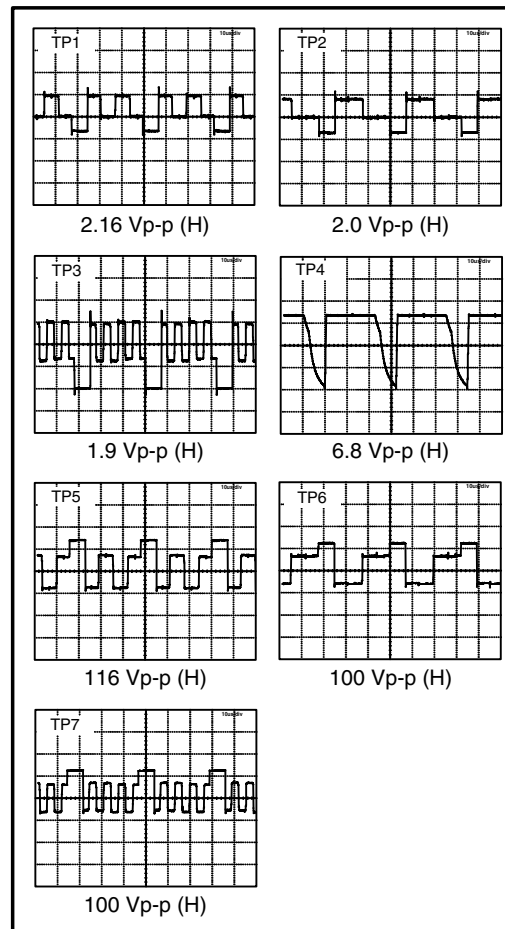

~ M Printed Wiring Board Conductor side B ~

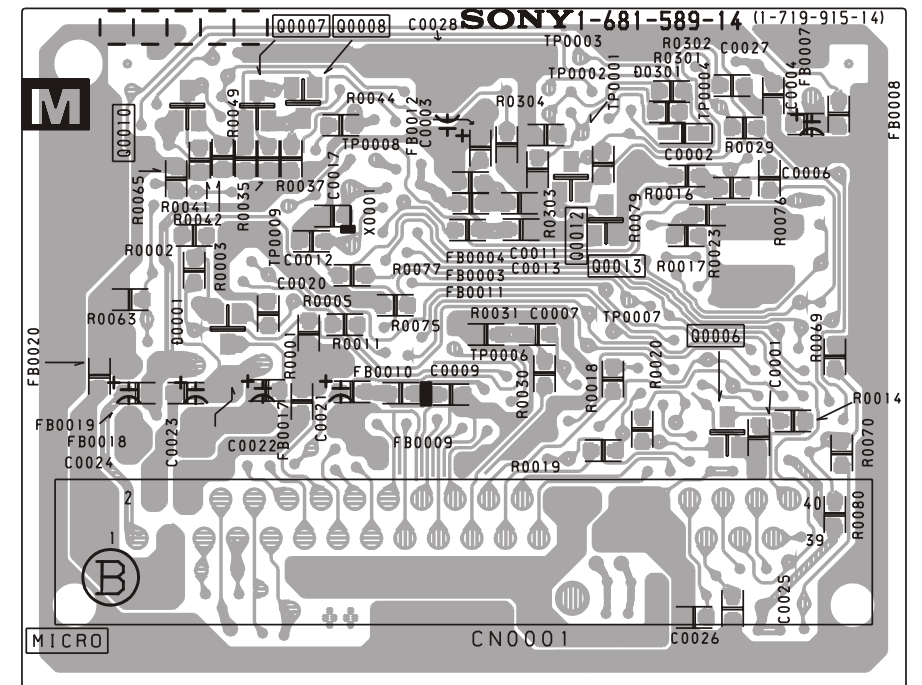

~ C Board Semiconductor Voltage Table ~

Ref	(e)	(b)	(c)
Q7350	12	11.98	0
Q7352	0	0	3.8
Q7353	0	0	3.8
Q7354	11.98	12	0
Q7355	0	0	3.8

~ C Board IC Voltage Table ~

IC Voltage Table			
Ref No	Pin No	Voltage (V)	
IC7300	1	3.9	
	3	3.8	
	5	7.5	
	6	200	
	7	140	
	8	153	
	9	140	
	IC7325	1	3.9
		3	3.8
5		7.7	
6		200	
7		140	
IC7350	1	3.9	
	3	3.8	
	5	7.5	
	6	200	
	7	139	
8	148		
9	138		

B-#SSAE6B<...>-M...-29XL70/71

COMPONENTS MARKED AS XX ARE NOT FITTED ON THIS MODEL

M MICRO PROCESSOR

TO A BOARD CN0101

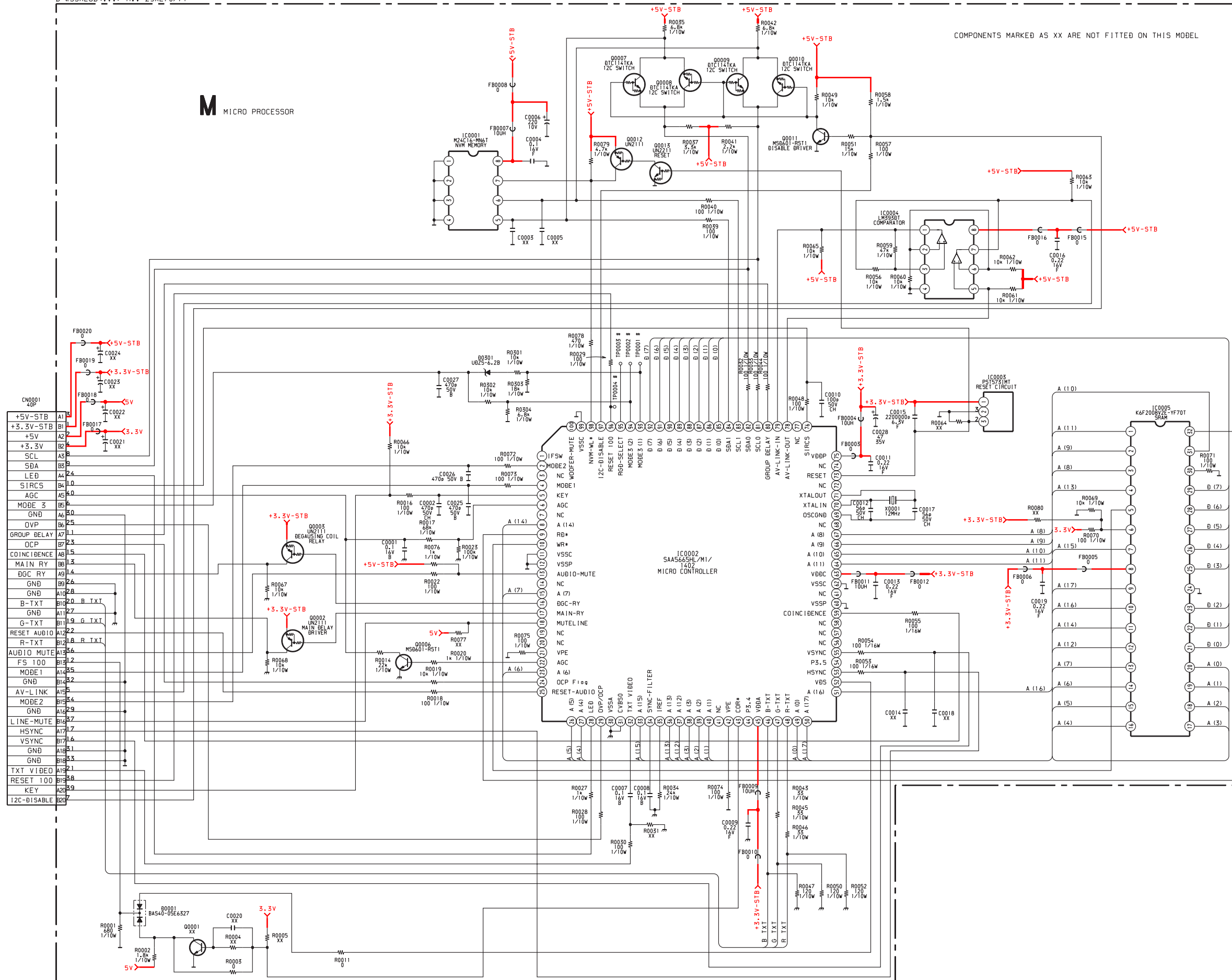

~ M Board Schematic Diagram [Micro Processor] ~

5-4. SEMICONDUCTORS

CXAB070AP
MCZ3001D

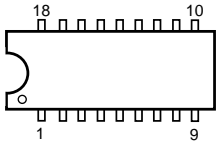

LM318P
LM358N
LM393DT
LM393N
M24C16-MN6T(A)

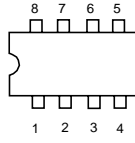

PST573IMT

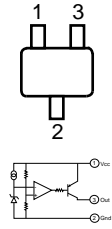

CXA1875AM-T4

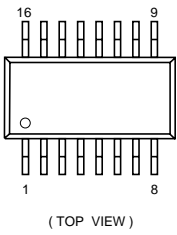

LM78L05ACZ

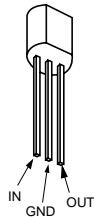

SAA5665HL/M1D/0358

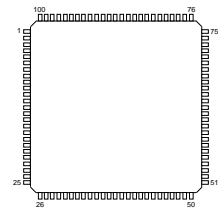

CXA2100AQ-TL

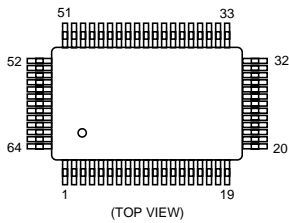

MSP3411G-QA-B10

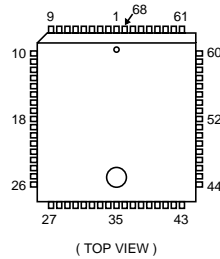

SBX3081-51(30)

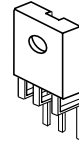

K6T2008V2A-YF70T00

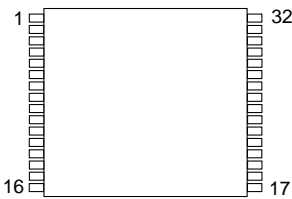

NJM3404AD-W
UPC4558G2

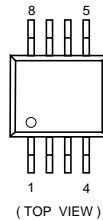

SDA9488X-B23GEG

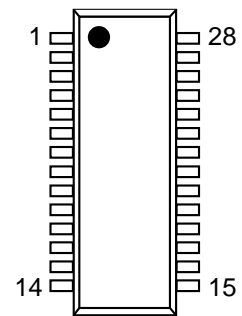

LA6500-FA

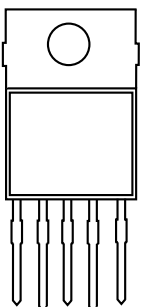

PQ30RV11

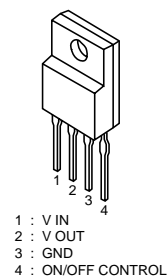

STV9379

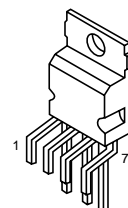

TCET1103G

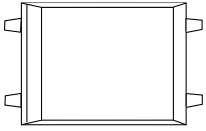

DTA144EK
DTC144TKA-T146
2SA1162-G

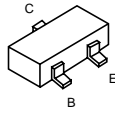

SE135N-LF4

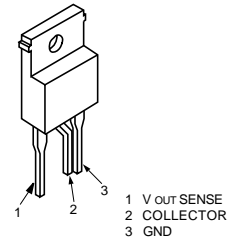

TDA6111Q/N4

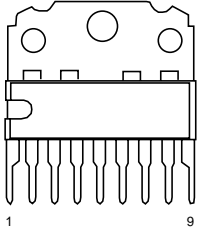

DTA144ESA
2SA933AS-QT
2SC2785-HFE

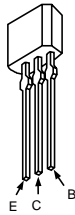

2SA1837(LBS2S0N)

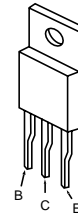

TDA7497

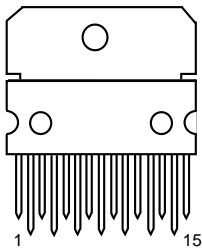

L7809CV/LSY
STP5NB40FP
STP5NB40(030Y)
2SC5698-CA
2S5696-SONY-CA

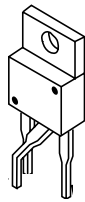

2SB734-34



VPS9402-A32GEG

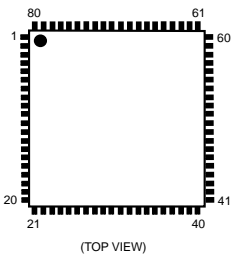

MSB709-RT1
MSD601-RST1
M1MA152WA-T1
UN2111
UN213
2SK2036(TE85L)

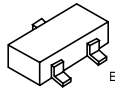

2SC2688(5)-LK

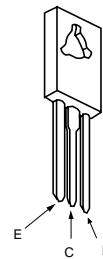

BA12T
BAO33T
IRF614-005
IRF620
SPA07N60C2
2SA2005
2SC5511

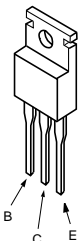

RB705D

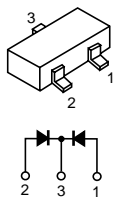

BAS216

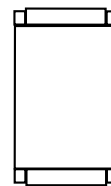

BAS316-115
 MMDL914T1
 UDZSTE-176.2B

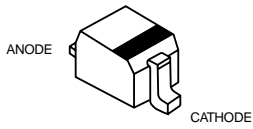

FBIU4D7MA-B
 RBV-406B
 S1VB40

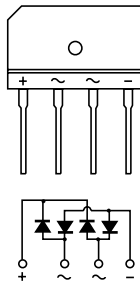

BYV98-200-RAS 15/12

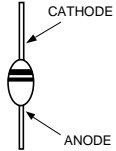

GS1B460/45

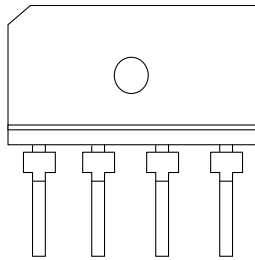

D1NL20U
 EGP20G
 EL1Z
 GP08D
 UF4005PKG23

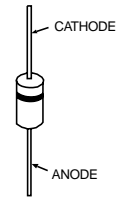

TLHK5190

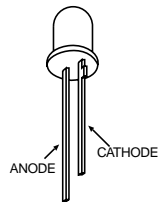

D2S4MTA1

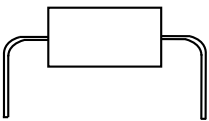

ERA38-06	MTZJ-T-77-22
ERA85-009	RD15ES-B2
HZS9.1NB2	RD39ES-B2
MTZJ-13B	RD5.6ESB2
MTZJ-33B	1SS119-25
MTZJ-3.6A	1SS133T-77
MTZJ-4.7C	

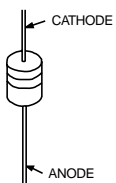

5-5 IC BLOCK DIAGRAMS

A BOARD IC6202/IC6205 BA033T/BA12T

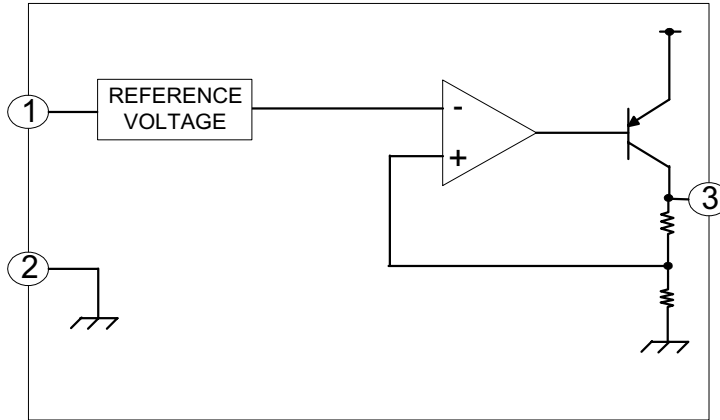

A BOARD IC2500 TDA7497

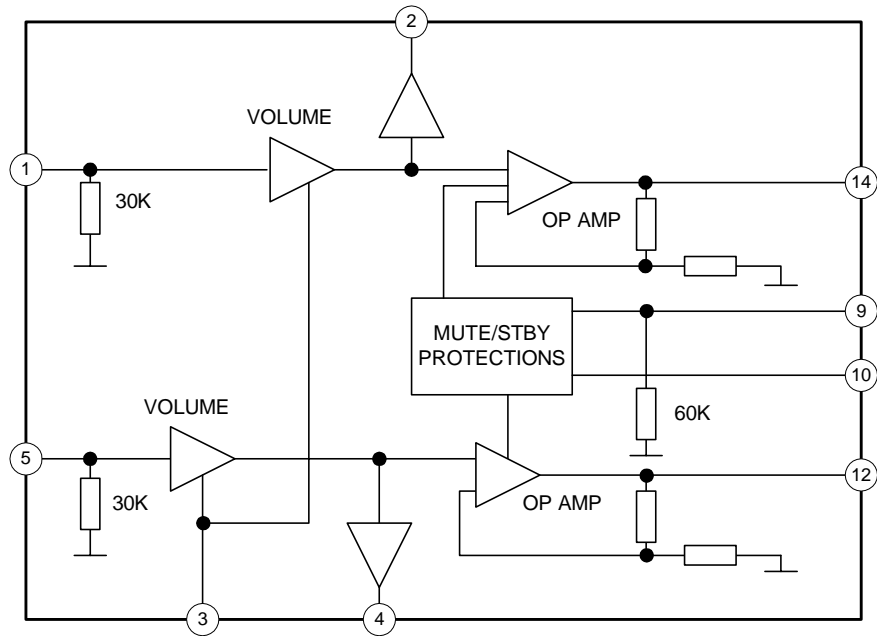

G BOARD IC6001 MCZ3001D

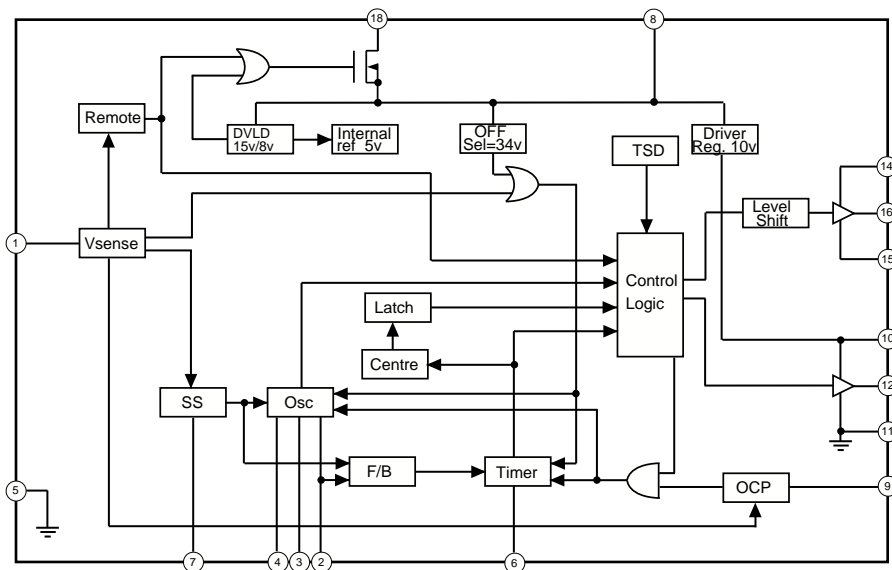

A BOARD IC2000 MSP3411G

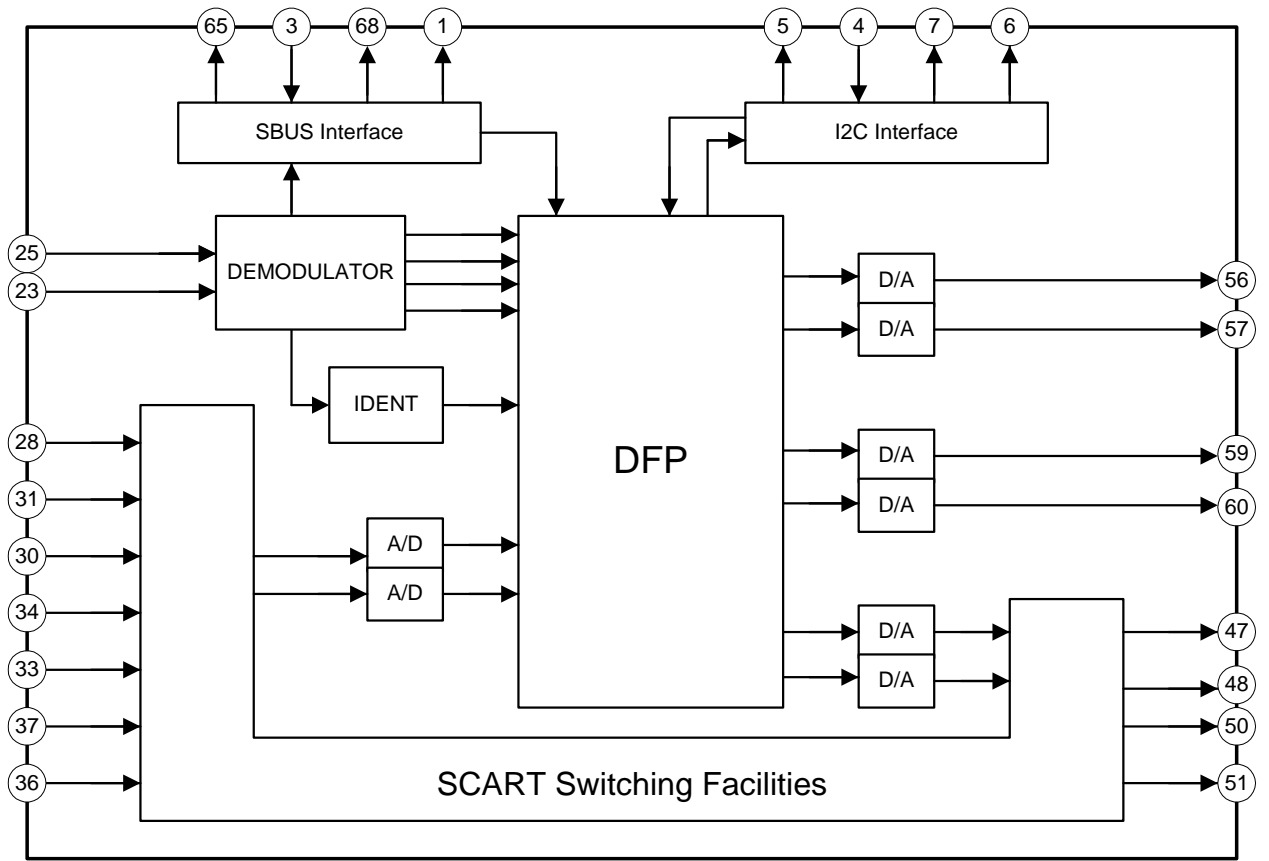

G BOARD IC6003 SE135N-LF4

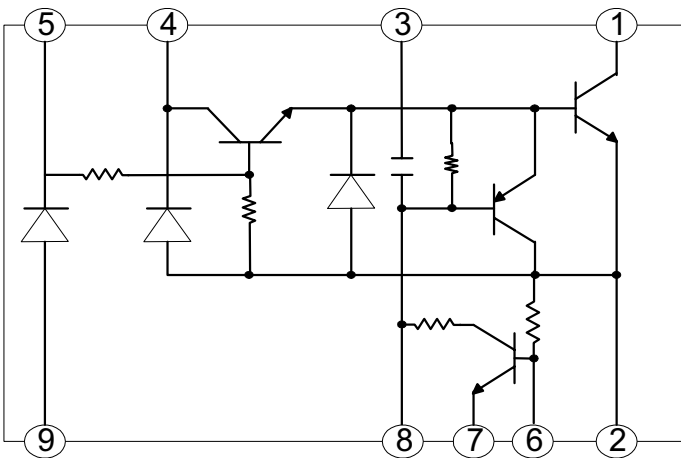

A BOARD IC5301/IC5302 LA6393DLL

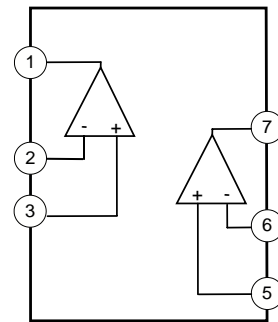

A BOARD IC5400 STV9379

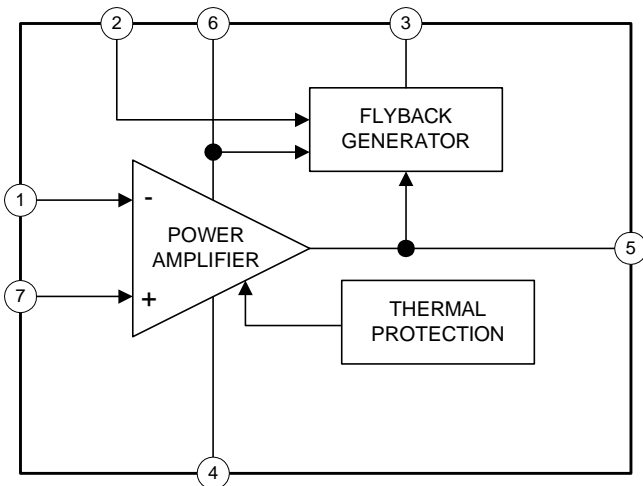

A BOARD IC5300 LM358N

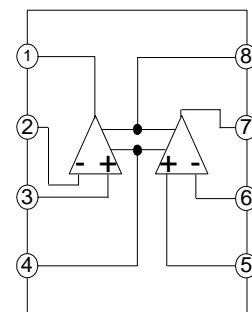

SECTION 6 EXPLODED VIEWS

NOTE :

- Items with no part number and no description are not stocked because they are seldom required for routine service.
- The construction parts of an assembled part are indicated with a collation number in the remarks column.
- Items marked “*” are not stocked since they are seldom required for routine service. Some delay should be anticipated when ordering these items.

6-1. CHASSIS

Note : Les composants identifiés par une trame et par une marque Δ sont d'une importance critique pour la sécurité. Ne les remplacer que par des pièces du numéro spécifié.

Note : The components identified by shading and marked Δ are critical for safety. Replace only with the part numbers specified in the parts list.

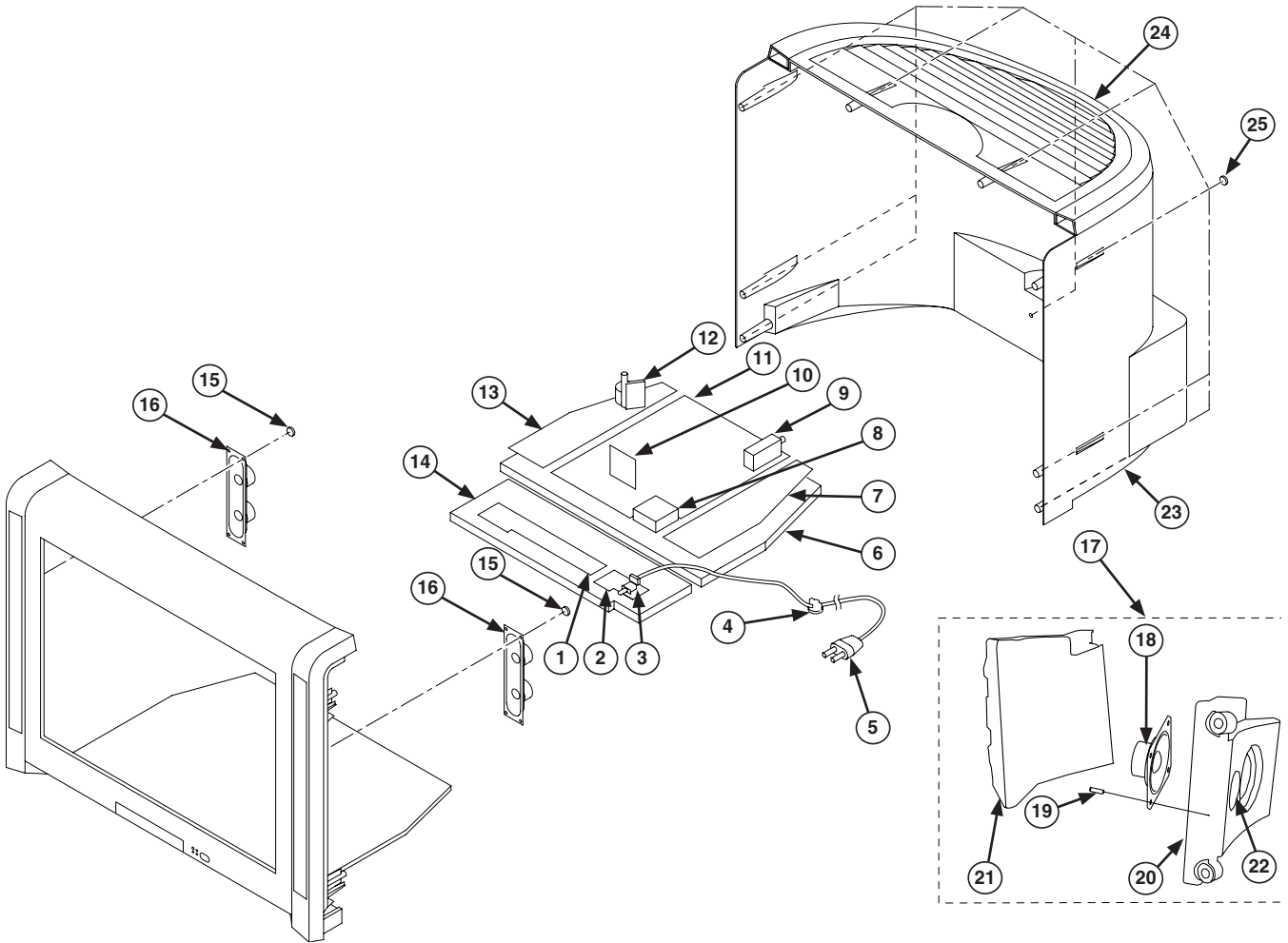

REF.NO.	PART.NO	DESCRIPTION	REMARK	REF.NO.	PART.NO	DESCRIPTION	REMARK
1	*A-1055-452-A	H6 BOARD COMPLETE		14	*4-103-134-01	BRACKET, H	
2	*A-1055-970-A	F1 BOARD, COMPLETE		15	4-058-870-01	SCREW (4x16)W(+)P TAPPING	
3	Δ 1-571-433-21	SWITCH, PUSH (AC POWER)		16	1-529-408-11	SPEAKER (4.2x24CM)	
4	*4-202-531-01	AC CORD LOCK (SC)		17	A-1606-689-A	WOOFER COMPLETE ASSY	18 - 22
5	Δ *1-823-853-11	CORD, POWER		18	1-910-000-50	WOOFER LS	
6	*4-206-106-06	BRACKET, MAIN		19	7-685-663-71	SCREW +BVTP 4x16 TYPE2 IT-3	
7	A-1637-024-A	G BOARD, COMPLETE		20	*4-102-535-01	WOOFER BAFFLE	
8	1-424-855-11	COIL, CHOKE 29MMH		21	*4-102-534-01	WOOFER BOX	
9	8-598-623-10	TUNER FSS BTP-AC421		22	*4-102-533-01	WOOFER PORT	
10	*A-1634-062-A	M BOARD, COMPLETE		23	4-103-130-01	REAR COVER	
11	*A-1632-952-A	A BOARD, COMPLETE		24	4-103-136-01	29 LOOP PAINTED	
12	Δ 1-453-340-41	TRANSFORMER ASSY, FLYBACK (NX-4522//Z2B4)		25	7-685-663-71	SCREW +BVTP 4x16 TYPE2 IT-3	
13	*A-1640-432-A	D BOARD, COMPLETE					

6-2. PICTURE TUBE

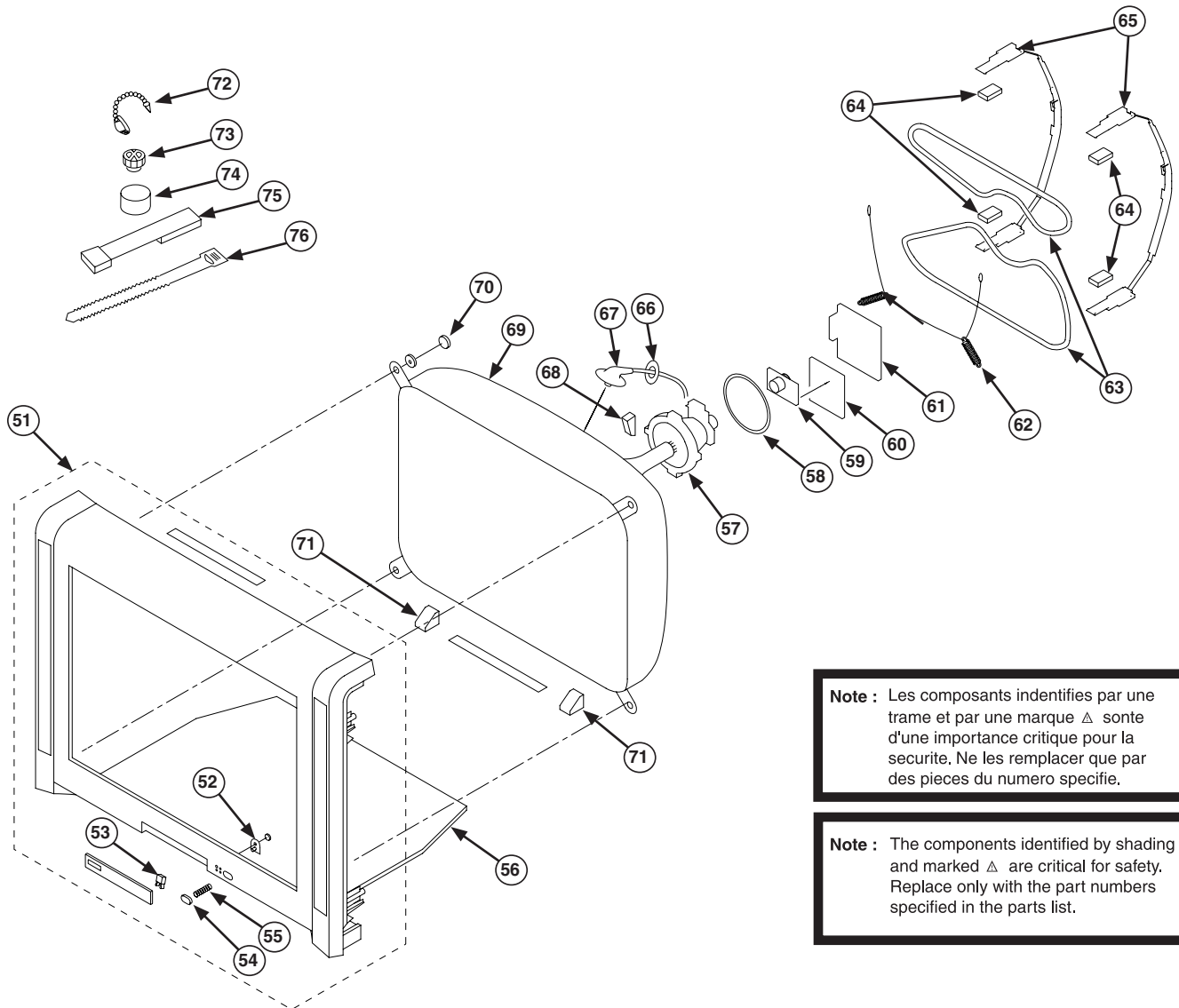

REF.NO.	PART.NO	DESCRIPTION	REMARK	REF.NO.	PART.NO	DESCRIPTION	REMARK
51	X-2021-299-1	BEZNET ASSY	52-55	64	*4-203-390-11	CUSHION, DGC	
52	4-205-375-01	GUIDE, LIGHT		65	*4-204-768-02	HOLDER, DGC (29")	
53	4-087-491-11	SPRING (DOOR)		66	4-202-554-02	HOLDER, HV CABLE	
54	4-102-532-01	POWER BUTTON		67	Δ 1-251-946-11	CAP ASSY, HIGH-VOLTAGE	
55	4-204-426-01	SPRING		68	3-704-495-03	SPACER, DY	
56	*4-103-133-01	CHASSIS BRACKET		69	Δ 8-735-097-05	PICTURE TUBE (M68LNH060X)	
57	Δ 8-451-504-31	DEFLECTION YOKE (Y29RSC-5)		70	4-046-765-12	SCREW, TAPPING 7+CROWN WASHER	
58	1-452-896-11	COIL, NA ROTATION (RT200)		71	*4-206-160-01	SUPPORT CRT	
59	Δ 8-453-021-21	NECK ASSY, (NA-2919-M2)		72	4-308-870-00	CLIP, LEAD WIRE	
60	*A-1300-626-A	VM BOARD, COMPLETE		73	1-452-094-00	MAGNET, ROTATABLE DISK; 15MM \varnothing	
61	*A-1055-968-A	C BOARD, COMPLETE		74	1-452-032-00	MAGNET, DISK; 10MM \varnothing	
62	4-369-318-21	SPRING, TENSION		75	X-4387-214-1	PERMALLOY, CORRECTION	
63	Δ 1-424-888-11	COIL, DEGAUSSING		76	3-701-007-00	BAND, BINDING	

SECTION 7 ELECTRICAL PARTS LIST

PARTS LISTING TABLE OF CONTENTS

	<u>Page</u>
H6 BOARD COMPLETE Parts List :	53
C BOARD COMPLETE Parts List :	53
F1 BOARD COMPLETE Parts List :	54
A BOARD COMPLETE Parts List :	55
M BOARD COMPLETE Parts List :	65
G BOARD COMPLETE Parts List :	66
D BOARD COMPLETE Parts List :	68
VM BOARD COMPLETE Parts List :	72
MISCELLANEOUS :	73
ACCESSORIES AND PACKAGING MATERIALS :	73
REMOTE COMMANDER:	73

Note : Items marked “*” are not stocked since they are seldom required for routine service. Some delay should be anticipated when ordering these items.
 Parts indicated (XX) on the Schematic Diagram are not used in this model and therefore do not appear in the Parts List.

REF.NO.	PART.NO	DESCRIPTION	REMARK	REF.NO.	PART.NO	DESCRIPTION	REMARK
* A-1055-452-A H6 Board Complete							
		< CAPACITOR >					
C2904	1-162-964-11	CERAMIC CHIP 0.001UF	10.00% 50V	C7304	1-107-967-11	ELECT 1UF	20.00% 400V
C2906	1-126-960-11	ELECT 1UF	20.00% 50V	C7305	1-136-207-11	MYLAR 0.047UF	5.00% 630V
C2907	1-126-960-11	ELECT 1UF	20.00% 50V	C7306	1-163-009-91	CERAMIC CHIP 0.001UF	10.00% 50V
C2931	1-162-964-11	CERAMIC CHIP 0.001UF	10.00% 50V	C7308	1-162-909-11	CERAMIC CHIP 4PF	0.25PF 50V
		< CONNECTOR >		C7309	1-163-035-00	CERAMIC CHIP 0.047UF	50V
CN2900	1-779-947-11	TERMINAL BLOCK, S		C7310	1-163-247-91	CERAMIC CHIP 68PF	5.00% 50V
CN2911	* 1-564-511-11	PLUG, CONNECTOR 8P		C7325	1-162-909-11	CERAMIC CHIP 4PF	0.25PF 50V
CN2912	* 1-564-510-11	PLUG, CONNECTOR 7P		C7326	1-163-009-91	CERAMIC CHIP 0.001UF	10.00% 50V
		< DIODE >		C7329	1-107-967-11	ELECT 1UF	20.00% 400V
D0908	8-719-923-60	DIODE MTZJ-T-77-9.1A		C7330	1-136-207-11	MYLAR 0.047UF	5.00% 630V
		< SOCKET >		C7331	1-162-909-11	CERAMIC CHIP 4PF	0.25PF 50V
J2901	1-750-264-11	JACK		C7333	1-163-035-00	CERAMIC CHIP 0.047UF	50V
		< RESISTOR >		C7334	1-163-247-91	CERAMIC CHIP 68PF	5.00% 50V
R0901	1-216-864-11	SHORT CHIP 0		C7350	1-126-947-11	ELECT 47UF	20.00% 35V
R0902	1-216-829-11	METAL CHIP 4.7K 5%	1/10W	C7351	1-162-909-11	CERAMIC CHIP 4PF	0.25PF 50V
R0911	1-216-829-11	METAL CHIP 4.7K 5%	1/10W	C7352	1-163-009-91	CERAMIC CHIP 0.001UF	10.00% 50V
R0912	1-216-864-11	SHORT CHIP 0		C7354	1-126-933-11	ELECT 100UF	20.00% 16V
R0913	1-216-833-11	METAL CHIP 10K 5%	1/10W	C7355	1-107-967-11	ELECT 1UF	20.00% 400V
R0914	1-216-833-11	METAL CHIP 10K 5%	1/10W	C7356	1-136-207-11	MYLAR 0.047UF	5.00% 630V
R2901	1-249-406-11	CARBON 120 5%	1/4W	C7358	1-162-909-11	CERAMIC CHIP 4PF	0.25PF 50V
R2902	1-249-406-11	CARBON 120 5%	1/4W	C7359	1-163-035-00	CERAMIC CHIP 0.047UF	50V
R2903	1-249-406-11	CARBON 120 5%	1/4W	C7360	1-163-247-91	CERAMIC CHIP 68PF	5.00% 50V
R2904	1-249-406-11	CARBON 120 5%	1/4W	C7378	1-162-116-00	CERAMIC 680PF	10.00% 2KV
R2909	1-216-853-11	METAL CHIP 470K 5%	1/10W	C7379	1-162-114-00	CERAMIC 0.0047UF	2KV
R2910	1-216-853-11	METAL CHIP 470K 5%	1/10W	C7380	1-107-655-11	ELECT 47UF	20.00% 250V
R2917	1-216-821-11	METAL CHIP 1K 5%	1/10W	C7384	1-162-911-11	CERAMIC CHIP 6PF	0.50PF 50V
R2918	1-216-821-11	METAL CHIP 1K 5%	1/10W	C7385	1-162-913-11	CERAMIC CHIP 8PF	0.50PF 50V
		< SWITCH >		C7387	1-162-911-11	CERAMIC CHIP 6PF	0.50PF 50V
S0900	1-692-431-21	SWITCH, TACTILE		C7388	1-162-913-11	CERAMIC CHIP 8PF	0.50PF 50V
S0901	1-692-431-21	SWITCH, TACTILE		C7390	1-162-911-11	CERAMIC CHIP 6PF	0.50PF 50V
S0902	1-692-431-21	SWITCH, TACTILE		C7391	1-162-913-11	CERAMIC CHIP 8PF	0.50PF 50V
S0903	1-692-431-21	SWITCH, TACTILE				< COATING LEAD >	
S0904	1-692-431-21	SWITCH, TACTILE		CL7301	* 4-102-022-01	PIN(30), WIRE	
S0905	1-692-431-21	SWITCH, TACTILE		CL7303	* 4-102-022-01	PIN(30), WIRE	
* A-1055-968-A C Board Complete						< CONNECTOR >	
	4-382-854-01	SCREW (M3X8), P, SW (+)		CN7300	* 1-564-508-11	PLUG, CONNECTOR 5P	
		< CAPACITOR >		CN7301	* 1-564-512-11	PLUG, CONNECTOR 9P	
C7303	1-162-909-11	CERAMIC CHIP 4PF	0.25PF 50V	CN7311	1-695-915-11	TAB (CONTACT)	
		< DIODE >		CN7333	1-695-915-11	TAB (CONTACT)	
D7300	8-719-911-19	DIODE 1SS119-25				< DIODE >	
D7325	8-719-911-19	DIODE 1SS119-25		D7300	8-719-911-19	DIODE 1SS119-25	
D7350	8-719-911-19	DIODE 1SS119-25		D7325	8-719-911-19	DIODE 1SS119-25	
D7375	8-719-991-33	DIODE 1SS133T-77		D7350	8-719-911-19	DIODE 1SS119-25	
D7376	8-719-991-33	DIODE 1SS133T-77		D7375	8-719-991-33	DIODE 1SS133T-77	
D7378	8-719-109-89	DIODE RD5.6ESB2		D7376	8-719-991-33	DIODE 1SS133T-77	

Note : The components identified by shading and marked Δ are critical for safety. Replace only with the part numbers specified in the parts list.

C F1

REF.NO.	PART.NO	DESCRIPTION	REMARK	REF.NO.	PART.NO	DESCRIPTION	REMARK
D7379	8-719-109-89	DIODE RD5.6ESB2		R7373	1-216-823-11	METAL CHIP 1.5K 5%	1/10W
D7380	8-719-302-43	DIODE EL1Z		R7374	1-216-819-11	METAL CHIP 680 5%	1/10W
D7381	8-719-302-43	DIODE EL1Z		R7375	1-249-435-11	CARBON 33K 5%	1/4W
D7382	8-719-302-43	DIODE EL1Z		R7376	1-249-429-11	CARBON 10K 5%	1/4W
	< IC >			R7377	1-249-430-11	CARBON 12K 5%	1/4W
IC7300	8-759-360-83	IC TDA6111Q/N4		R7379	1-216-833-11	METAL CHIP 10K 5%	1/10W
IC7325	8-759-360-83	IC TDA6111Q/N4		R7380	1-216-833-11	METAL CHIP 10K 5%	1/10W
IC7350	8-759-360-83	IC TDA6111Q/N4		R7381	1-216-833-11	METAL CHIP 10K 5%	1/10W
	< SOCKET >			R7382	1-202-549-00	SOLID 100 20%	1/2W
J7375	Δ 1-251-732-11	SOCKET, CRT		R7383	1-216-349-00	METAL OXIDE 1 5%	1W
	< COIL >			R7385	1-202-549-00	SOLID 100 20%	1/2W
L7375	1-410-671-31	INDUCTOR 47UH		R7387	1-247-735-11	CARBON 47 5%	1/2W
L7376	Δ 1-532-637-00	IC LINK 1A 50V		R7388	1-535-143-51	LEAD, JUMPER (20.0MM)	
L7378	1-414-934-21	INDUCTOR 10UH		R7389	1-247-881-00	CARBON 120K 5%	1/4W
	< TRANSISTOR >			R7390	1-249-417-11	CARBON 1K 5%	1/4W
Q7350	8-729-901-06	TRANSISTOR DTA144EK		R7391	1-216-824-11	METAL CHIP 1.8K 5%	1/10W
Q7352	8-729-421-19	TRANSISTOR UN2213		R7392	1-216-819-11	METAL CHIP 680 5%	1/10W
Q7353	8-729-421-19	TRANSISTOR UN2213		R7393	1-216-823-11	METAL CHIP 1.5K 5%	1/10W
Q7354	8-729-901-06	TRANSISTOR DTA144EK		R7394	1-249-417-11	CARBON 1K 5%	1/4W
Q7355	8-729-421-19	TRANSISTOR UN2213		R7395	1-216-824-11	METAL CHIP 1.8K 5%	1/10W
	< RESISTOR >			R7396	1-216-819-11	METAL CHIP 680 5%	1/10W
R7300	1-249-417-11	CARBON 1K 5%	1/4W	R7397	1-216-823-11	METAL CHIP 1.5K 5%	1/10W
R7302	1-535-303-00	LEAD, JUMPER (5.0MM)		R7398	1-249-417-11	CARBON 1K 5%	1/4W
R7303	1-216-824-11	METAL CHIP 1.8K 5%	1/10W	R7399	1-216-824-11	METAL CHIP 1.8K 5%	1/10W
R7304	1-260-095-11	CARBON 470 5%	1/2W		< RESISTOR VARIABLE >		
R7305	1-215-903-11	METAL OXIDE 68K 5%	2W	RV7375	1-241-656-11	RES, ADJ, METAL FILM 110M	
R7306	1-535-303-00	LEAD, JUMPER (5.0MM)			* A-1055-970-A F1 Board Complete		
R7309	1-216-824-11	METAL CHIP 1.8K 5%	1/10W		4-206-220-01	HOLDER, LED	
R7310	1-216-819-11	METAL CHIP 680 5%	1/10W		* 4-374-846-01	COVER, CAPACITOR, CAP TYPE	
R7325	1-249-417-11	CARBON 1K 5%	1/4W		< CAPACITOR >		
R7327	1-535-303-00	LEAD, JUMPER (5.0MM)		C0982	1-104-665-11	ELECT 100UF	20.00% 25V
R7328	1-216-824-11	METAL CHIP 1.8K 5%	1/10W	C0983	1-102-114-00	CERAMIC 470PF	10.00% 50V
R7329	1-260-095-11	CARBON 470 5%	1/2W	C0984	1-102-129-00	CERAMIC 0.01UF	10.00% 50V
R7330	1-215-903-11	METAL OXIDE 68K 5%	2W	C6400	1-113-924-11	CERAMIC 0.0047UF	20.00% 250V
R7331	1-535-303-00	LEAD, JUMPER (5.0MM)			< CONNECTOR >		
R7334	1-216-819-11	METAL CHIP 680 5%	1/10W	CN0981	* 1-564-507-11	PLUG, CONNECTOR 4P	
R7335	1-216-824-11	METAL CHIP 1.8K 5%	1/10W	CN6400	Δ * 1-580-843-11	PIN, CONNECTOR (POWER)	
R7350	1-249-417-11	CARBON 1K 5%	1/4W	CN6401	Δ * 1-691-291-11	PIN, CONNECTOR (PC BOARD) 5P	
R7355	1-535-303-00	LEAD, JUMPER (5.0MM)		CN6403	1-695-915-11	TAB (CONTACT)	
R7356	1-216-824-11	METAL CHIP 1.8K 5%	1/10W		< DIODE >		
R7357	1-260-095-11	CARBON 470 5%	1/2W	D0981	8-719-109-89	DIODE RD5.6ESB2	
R7358	1-215-903-11	METAL OXIDE 68K 5%	2W	D0983	8-719-082-12	DIODE TLHK5190	
R7360	1-535-303-00	LEAD, JUMPER (5.0MM)					
R7363	1-216-819-11	METAL CHIP 680 5%	1/10W				
R7364	1-216-824-11	METAL CHIP 1.8K 5%	1/10W				

Note : The components identified by shading and marked Δ are critical for safety. Replace only with the part numbers specified in the parts list.

F1 **A**

REF.NO.	PART.NO	DESCRIPTION	REMARK	REF.NO.	PART.NO	DESCRIPTION	REMARK
< FUSE >				C1034	1-126-933-11	ELECT 100UF	20.00% 16V
F6400	Δ 1-576-232-12	FUSE	5A 250V	C1035	1-126-964-11	ELECT 10UF	20.00% 50V
FH6400	Δ 1-533-725-11	FUSE HOLDER		C1037	1-164-315-11	CERAMIC CHIP 470PF	5.00% 50V
< IC >				C1039	1-107-826-11	CERAMIC CHIP 0.1UF	10.00% 16V
IC0981	6-600-129-01	IC RPM7140-H5		C1040	1-162-970-11	CERAMIC CHIP 0.01UF	10.00% 25V
< RESISTOR >				C2000	1-162-968-11	CERAMIC CHIP 0.0047UF	10.00% 50V
R0982	1-247-807-31	CARBON 100 5% 1/4W		C2001	1-162-968-11	CERAMIC CHIP 0.0047UF	10.00% 50V
R6400	Δ 1-202-719-00	SOLID 1M 10% 1/2W		C2006	1-162-962-11	CERAMIC CHIP 470PF	10.00% 50V
< SWITCH >				C2007	1-163-021-91	CERAMIC CHIP 0.01UF	10.00% 50V
S6400	Δ 1-571-433-21	SWITCH, PUSH (AC POWER)		C2008	1-162-964-11	CERAMIC CHIP 0.001UF	10.00% 50V
< VARISTOR >				C2009	1-163-021-91	CERAMIC CHIP 0.01UF	10.00% 50V
VDR6400	Δ 1-803-830-11	VARISTOR (ERZV14D621)		C2010	1-162-964-11	CERAMIC CHIP 0.001UF	10.00% 50V
* A-1632-952-A A Board Complete				C2011	1-162-962-11	CERAMIC CHIP 470PF	10.00% 50V
4-382-854-01		SCREW (M3X8), P, SW (+)		C2012	1-162-962-11	CERAMIC CHIP 470PF	10.00% 50V
< CAPACITOR >				C2013	1-162-962-11	CERAMIC CHIP 470PF	10.00% 50V
C1002	1-162-925-11	CERAMIC CHIP 68PF	5.00% 50V	C2014	1-164-346-11	CERAMIC CHIP 1UF	16V
C1003	1-162-925-11	CERAMIC CHIP 68PF	5.00% 50V	C2015	1-163-021-91	CERAMIC CHIP 0.01UF	10.00% 50V
C1004	1-126-933-11	ELECT 100UF	20.00% 16V	C2016	1-162-962-11	CERAMIC CHIP 470PF	10.00% 50V
C1005	1-163-021-91	CERAMIC CHIP 0.01UF	10.00% 50V	C2018	1-162-962-11	CERAMIC CHIP 470PF	10.00% 50V
C1006	1-126-933-11	ELECT 100UF	20.00% 16V	C2019	1-164-346-11	CERAMIC CHIP 1UF	16V
C1008	1-163-021-91	CERAMIC CHIP 0.01UF	10.00% 50V	C2021	1-162-962-11	CERAMIC CHIP 470PF	10.00% 50V
C1010	1-162-970-11	CERAMIC CHIP 0.01UF	10.00% 25V	C2022	1-162-966-11	CERAMIC CHIP 0.0022UF	10.00% 50V
C1011	1-126-947-11	ELECT 47UF	20.00% 35V	C2023	1-162-966-11	CERAMIC CHIP 0.0022UF	10.00% 50V
C1012	1-162-970-11	CERAMIC CHIP 0.01UF	10.00% 25V	C2024	1-164-346-11	CERAMIC CHIP 1UF	16V
C1013	1-163-131-00	CERAMIC CHIP 390PF	5.00% 50V	C2026	1-162-962-11	CERAMIC CHIP 470PF	10.00% 50V
C1014	1-162-970-11	CERAMIC CHIP 0.01UF	10.00% 25V	C2027	1-126-947-11	ELECT 47UF	20.00% 35V
C1015	1-162-970-11	CERAMIC CHIP 0.01UF	10.00% 25V	C2028	1-126-947-11	ELECT 47UF	20.00% 35V
C1016	1-125-891-11	CERAMIC CHIP 0.47UF	10.00% 10V	C2029	1-164-346-11	CERAMIC CHIP 1UF	16V
C1017	1-127-715-91	CERAMIC CHIP 0.22UF	10.00% 16V	C2031	1-162-962-11	CERAMIC CHIP 470PF	10.00% 50V
C1018	1-115-340-11	CERAMIC CHIP 0.22UF	10.00% 25V	C2034	1-164-346-11	CERAMIC CHIP 1UF	16V
C1019	1-162-927-11	CERAMIC CHIP 100PF	5.00% 50V	C2035	1-164-346-11	CERAMIC CHIP 1UF	16V
C1020	1-164-004-11	CERAMIC CHIP 0.1UF	10.00% 25V	C2038	1-162-970-11	CERAMIC CHIP 0.01UF	10.00% 25V
C1021	1-107-826-11	CERAMIC CHIP 0.1UF	10.00% 16V	C2039	1-162-906-11	CERAMIC CHIP 1.5PF	0.25PF 50V
C1024	1-162-919-11	CERAMIC CHIP 22PF	5.00% 50V	C2040	1-162-964-11	CERAMIC CHIP 0.001UF	10.00% 50V
C1025	1-216-864-11	SHORT CHIP 0		C2041	1-162-906-11	CERAMIC CHIP 1.5PF	0.25PF 50V
C1026	1-162-970-11	CERAMIC CHIP 0.01UF	10.00% 25V	C2042	1-163-249-11	CERAMIC CHIP 82PF	5.00% 50V
C1027	1-162-926-11	CERAMIC CHIP 82PF	5.00% 50V	C2043	1-162-962-11	CERAMIC CHIP 470PF	10.00% 50V
C1028	1-164-388-91	CERAMIC CHIP 270PF	5.00% 50V	C2044	1-163-021-91	CERAMIC CHIP 0.01UF	10.00% 50V
C1029	1-162-915-11	CERAMIC CHIP 10PF	0.50PF 50V	C2046	1-162-923-11	CERAMIC CHIP 47PF	5.00% 50V
C1030	1-162-928-11	CERAMIC CHIP 120PF	5.00% 50V	C2047	1-162-927-11	CERAMIC CHIP 100PF	5.00% 50V
C1031	1-162-970-11	CERAMIC CHIP 0.01UF	10.00% 25V	C2048	1-126-947-11	ELECT 47UF	20.00% 35V
				C2049	1-162-925-11	CERAMIC CHIP 68PF	5.00% 50V
				C2050	1-107-823-11	CERAMIC CHIP 0.47UF	10.00% 16V
				C2051	1-126-964-11	ELECT 10UF	20.00% 50V
				C2052	1-164-004-11	CERAMIC CHIP 0.1UF	10.00% 25V
				C2053	1-164-227-11	CERAMIC CHIP 0.022UF	10.00% 25V
				C2054	1-126-947-11	ELECT 47UF	20.00% 35V
				C2055	1-162-968-11	CERAMIC CHIP 0.0047UF	10.00% 50V
				C2057	1-126-964-11	ELECT 10UF	20.00% 50V
				C2058	1-164-004-11	CERAMIC CHIP 0.1UF	10.00% 25V

REF.NO.	PART.NO	DESCRIPTION	REMARK	REF.NO.	PART.NO	DESCRIPTION	REMARK
C2059	1-126-964-11	ELECT 10UF	20.00% 50V	C2523	1-115-339-11	CERAMIC CHIP 0.1UF	10.00% 50V
C2060	1-126-947-11	ELECT 47UF	20.00% 35V	C3101	1-163-021-91	CERAMIC CHIP 0.01UF	10.00% 50V
C2061	1-162-968-11	CERAMIC CHIP 0.0047UF	10.00% 50V	C3102	1-163-021-91	CERAMIC CHIP 0.01UF	10.00% 50V
C2062	1-164-346-11	CERAMIC CHIP 1UF	16V	C3103	1-163-021-91	CERAMIC CHIP 0.01UF	10.00% 50V
C2063	1-164-346-11	CERAMIC CHIP 1UF	16V	C3104	1-163-021-91	CERAMIC CHIP 0.01UF	10.00% 50V
C2064	1-126-964-11	ELECT 10UF	20.00% 50V	C3105	1-163-021-91	CERAMIC CHIP 0.01UF	10.00% 50V
C2065	1-162-966-11	CERAMIC CHIP 0.0022UF	10.00% 50V	C3106	1-163-021-91	CERAMIC CHIP 0.01UF	10.00% 50V
C2066	1-162-966-11	CERAMIC CHIP 0.0022UF	10.00% 50V	C3107	1-163-021-91	CERAMIC CHIP 0.01UF	10.00% 50V
C2069	1-127-715-91	CERAMIC CHIP 0.22UF	10% 16V	C3108	1-163-021-91	CERAMIC CHIP 0.01UF	10.00% 50V
C2073	1-126-960-11	ELECT 1UF	20.00% 50V	C3109	1-163-021-91	CERAMIC CHIP 0.01UF	10.00% 50V
C2074	1-126-960-11	ELECT 1UF	20.00% 50V	C3112	1-126-964-11	ELECT 10UF	20.00% 50V
C2075	1-126-960-11	ELECT 1UF	20.00% 50V	C3113	1-126-963-11	ELECT 4.7UF	20.00% 50V
C2077	1-126-960-11	ELECT 1UF	20.00% 50V	C3114	1-126-963-11	ELECT 4.7UF	20.00% 50V
C2078	1-126-963-11	ELECT 4.7UF	20.00% 50V	C3115	1-126-963-11	ELECT 4.7UF	20.00% 50V
C2079	1-164-004-11	CERAMIC CHIP 0.1UF	10.00% 25V	C3116	1-126-964-11	ELECT 10UF	20.00% 50V
C2080	1-162-927-11	CERAMIC CHIP 100PF	5.00% 50V	C3117	1-126-964-11	ELECT 10UF	20.00% 50V
C2081	1-163-139-00	CERAMIC CHIP 820PF	5.00% 50V	C3118	1-162-970-11	CERAMIC CHIP 0.01UF	10.00% 25V
C2082	1-163-249-11	CERAMIC CHIP 82PF	5.00% 50V	C3119	1-162-970-11	CERAMIC CHIP 0.01UF	10.00% 25V
C2083	1-162-964-11	CERAMIC CHIP 0.001UF	10.00% 50V	C3200	1-126-964-11	ELECT 10UF	20.00% 50V
C2084	1-162-962-11	CERAMIC CHIP 470PF	10.00% 50V	C3202	1-126-964-11	ELECT 10UF	20.00% 50V
C2085	1-163-021-91	CERAMIC CHIP 0.01UF	10.00% 50V	C3203	1-126-964-11	ELECT 10UF	20.00% 50V
C2086	1-162-964-11	CERAMIC CHIP 0.001UF	10.00% 50V	C3206	1-126-964-11	ELECT 10UF	20.00% 50V
C2087	1-163-021-91	CERAMIC CHIP 0.01UF	10.00% 50V	C3208	1-163-235-11	CERAMIC CHIP 22PF	5.00% 50V
C2088	1-162-964-11	CERAMIC CHIP 0.001UF	10.00% 50V	C3209	1-163-235-11	CERAMIC CHIP 22PF	5.00% 50V
C2089	1-162-962-11	CERAMIC CHIP 470PF	10.00% 50V	C3210	1-126-964-11	ELECT 10UF	20.00% 50V
C2090	1-126-947-11	ELECT 47UF	20.00% 35V	C3211	1-126-964-11	ELECT 10UF	20.00% 50V
C2091	1-126-947-11	ELECT 47UF	20.00% 35V	C3212	1-107-826-11	CERAMIC CHIP 0.1UF	10.00% 16V
C2092	1-126-947-11	ELECT 47UF	20.00% 35V	C3213	1-164-222-91	CERAMIC CHIP 0.22UF	25V
C2093	1-126-947-11	ELECT 47UF	20.00% 35V	C3214	1-164-222-91	CERAMIC CHIP 0.22UF	25V
C2094	1-126-947-11	ELECT 47UF	20.00% 35V	C3215	1-164-222-91	CERAMIC CHIP 0.22UF	25V
C2095	1-126-947-11	ELECT 47UF	20.00% 35V	C3216	1-164-222-91	CERAMIC CHIP 0.22UF	25V
C2096	1-162-970-11	CERAMIC CHIP 0.01UF	10.00% 25V	C3217	1-164-222-91	CERAMIC CHIP 0.22UF	25V
C2500	1-126-952-11	ELECT 1000UF	20.00% 35V	C3218	1-164-222-91	CERAMIC CHIP 0.22UF	25V
C2502	1-104-666-11	ELECT 220UF	20.00% 25V	C3219	1-164-222-91	CERAMIC CHIP 0.22UF	25V
C2504	1-164-222-91	CERAMIC CHIP 0.22UF	25V	C3220	1-164-222-91	CERAMIC CHIP 0.22UF	25V
C2505	1-115-339-11	CERAMIC CHIP 0.1UF	10.00% 50V	C3221	1-164-222-91	CERAMIC CHIP 0.22UF	25V
C2506	1-126-972-11	ELECT 1000UF	20.00% 50V	C3222	1-164-222-91	CERAMIC CHIP 0.22UF	25V
C2507	1-164-230-11	CERAMIC CHIP 220PF	5.00% 50V	C3223	1-164-222-91	CERAMIC CHIP 0.22UF	25V
C2508	1-164-230-11	CERAMIC CHIP 220PF	5.00% 50V	C3224	1-164-222-91	CERAMIC CHIP 0.22UF	25V
C2509	1-164-230-11	CERAMIC CHIP 220PF	5.00% 50V	C3225	1-164-222-91	CERAMIC CHIP 0.22UF	25V
C2510	1-164-227-11	CERAMIC CHIP 0.022UF	10.00% 25V	C3226	1-164-222-91	CERAMIC CHIP 0.22UF	25V
C2511	1-163-021-91	CERAMIC CHIP 0.01UF	10.00% 50V	C3227	1-164-222-91	CERAMIC CHIP 0.22UF	25V
C2512	1-163-021-91	CERAMIC CHIP 0.01UF	10.00% 50V	C3228	1-164-489-11	CERAMIC CHIP 0.22UF	10.00% 16V
C2513	1-126-952-11	ELECT 1000UF	20.00% 35V	C3229	1-164-489-11	CERAMIC CHIP 0.22UF	10.00% 16V
C2515	1-164-227-11	CERAMIC CHIP 0.022UF	10.00% 25V	C3230	1-164-489-11	CERAMIC CHIP 0.22UF	10.00% 16V
C2516	1-126-953-11	ELECT 2200UF	20.00% 35V	C3231	1-164-489-11	CERAMIC CHIP 0.22UF	10.00% 16V
C2517	1-126-960-11	ELECT 1UF	20.00% 50V	C3232	1-164-489-11	CERAMIC CHIP 0.22UF	10.00% 16V
C2518	1-126-960-11	ELECT 1UF	20.00% 50V	C3233	1-164-489-11	CERAMIC CHIP 0.22UF	10.00% 16V
C2519	1-126-959-11	ELECT 0.47UF	20.00% 50V	C3234	1-164-489-11	CERAMIC CHIP 0.22UF	10.00% 16V
C2521	1-164-489-11	CERAMIC CHIP 0.22UF	10.00% 16V	C3235	1-165-176-11	CERAMIC CHIP 0.047UF	10.00% 16V

REF.NO.	PART.NO	DESCRIPTION	REMARK	REF.NO.	PART.NO	DESCRIPTION	REMARK
C3236	1-165-176-11	CERAMIC CHIP 0.047UF	10.00% 16V	C5303	1-136-153-00	FILM 0.01UF	5.00% 50V
C3237	1-165-176-11	CERAMIC CHIP 0.047UF	10.00% 16V	C5304	1-164-182-11	CERAMIC CHIP 0.0033UF	10.00% 50V
C3238	1-165-176-11	CERAMIC CHIP 0.047UF	10.00% 16V	C5305	1-165-176-11	CERAMIC CHIP 0.047UF	10.00% 16V
C3239	1-165-176-11	CERAMIC CHIP 0.047UF	10.00% 16V	C5306	1-164-156-11	CERAMIC CHIP 0.1UF	25V
C3240	1-165-176-11	CERAMIC CHIP 0.047UF	10.00% 16V	C5307	1-164-156-11	CERAMIC CHIP 0.1UF	25V
C3241	1-126-933-11	ELECT 100UF	20.00% 16V	C5309	1-162-927-11	CERAMIC CHIP 100PF	5.00% 50V
C3242	1-162-970-11	CERAMIC CHIP 0.01UF	10.00% 25V	C5310	1-136-497-81	FILM 0.1UF	5.00% 50V
C3243	1-164-222-91	CERAMIC CHIP 0.22UF	25V	C5311	1-164-156-11	CERAMIC CHIP 0.1UF	25V
C3244	1-163-247-91	CERAMIC CHIP 68PF	5.00% 50V	C5312	1-165-176-11	CERAMIC CHIP 0.047UF	10.00% 16V
C3245	1-163-251-11	CERAMIC CHIP 100PF	5.00% 50V	C5313	1-107-714-11	ELECT 10UF	20.00% 50V
C3250	1-163-021-91	CERAMIC CHIP 0.01UF	10.00% 50V	C5314	1-162-970-11	CERAMIC CHIP 0.01UF	10.00% 25V
C3300	1-163-251-11	CERAMIC CHIP 100PF	5.00% 50V	C5316	1-164-230-11	CERAMIC CHIP 220PF	5.00% 50V
C3309	1-126-964-11	ELECT 10UF	20.00% 50V	C5318	1-164-156-11	CERAMIC CHIP 0.1UF	25V
C3310	1-164-222-91	CERAMIC CHIP 0.22UF	25V	C5319	1-136-347-11	FILM 0.0047UF	5.00% 630V
C5110	1-126-947-11	ELECT 47UF	20.00% 35V	C5320	1-129-716-00	FILM 0.015UF	5.00% 630V
C5111	1-126-964-11	ELECT 10UF	20.00% 50V	C5321	1-136-347-11	FILM 0.0047UF	5.00% 630V
C5112	1-126-964-11	ELECT 10UF	20.00% 50V	C5322	1-164-156-11	CERAMIC CHIP 0.1UF	25V
C5114	1-164-156-11	CERAMIC CHIP 0.1UF	25V	C5323	1-136-159-00	FILM 0.033UF	5.00% 50V
C5115	1-126-964-11	ELECT 10UF	20.00% 50V	C5400	1-126-964-11	ELECT 10UF	20.00% 50V
C5116	1-126-964-11	ELECT 10UF	20.00% 50V	C5401	1-107-714-11	ELECT 10UF	20.00% 50V
C5117	1-126-964-11	ELECT 10UF	20.00% 50V	C5403	1-128-527-11	ELECT 330UF	20.00% 25V
C5118	1-164-156-11	CERAMIC CHIP 0.1UF	25V	C5404	1-102-228-00	CERAMIC 470PF	10.00% 500V
C5119	1-107-823-11	CERAMIC CHIP 0.47UF	10.00% 16V	C5405	1-163-021-91	CERAMIC CHIP 0.01UF	10.00% 50V
C5120	1-165-176-11	CERAMIC CHIP 0.047UF	10.00% 16V	C5406	1-129-702-00	MYLAR 0.001UF	10.00% 400V
C5121	1-165-176-11	CERAMIC CHIP 0.047UF	10.00% 16V	C5407	1-128-527-11	ELECT 330UF	20.00% 25V
C5122	1-164-156-11	CERAMIC CHIP 0.1UF	25V	C5409	1-126-968-11	ELECT 100UF	20.00% 50V
C5124	1-164-156-11	CERAMIC CHIP 0.1UF	25V	C5410	1-163-021-91	CERAMIC CHIP 0.01UF	10.00% 50V
C5125	1-126-964-11	ELECT 10UF	20.00% 50V	C5411	1-137-401-11	MYLAR 0.22UF	5.00% 100V
C5200	1-136-177-00	FILM 1UF	5.00% 50V	C5412	1-106-220-00	MYLAR 0.1UF	10.00% 100V
C5201	1-163-989-11	CERAMIC CHIP 0.033UF	10.00% 25V	C5413	1-130-785-11	MYLAR 0.47UF	5.00% 100V
C5202	1-126-947-11	ELECT 47UF	20.00% 35V	C5414	1-126-964-11	ELECT 10UF	20.00% 50V
C5203	1-136-177-00	FILM 1UF	5.00% 50V	C5801	1-126-963-11	ELECT 4.7UF	20.00% 50V
C5204	1-115-339-11	CERAMIC CHIP 0.1UF	10.00% 50V	C5850	1-126-963-11	ELECT 4.7UF	20.00% 50V
C5205	1-163-989-11	CERAMIC CHIP 0.033UF	10.00% 25V	C5851	1-107-826-11	CERAMIC CHIP 0.1UF	10.00% 16V
C5206	1-164-222-91	CERAMIC CHIP 0.22UF	25V	C5853	1-162-970-11	CERAMIC CHIP 0.01UF	10.00% 25V
C5207	1-126-947-11	ELECT 47UF	20.00% 35V	C5854	1-107-826-11	CERAMIC CHIP 0.1UF	10.00% 16V
C5209	1-163-127-00	CERAMIC CHIP 270PF	5.00% 50V	C5858	1-107-826-11	CERAMIC CHIP 0.1UF	10.00% 16V
C5210	1-164-336-11	CERAMIC CHIP 0.33UF	25V	C5859	1-126-960-11	ELECT 1UF	20.00% 50V
C5211	1-136-497-81	FILM 0.1UF	5.00% 50V	C5860	1-165-176-11	CERAMIC CHIP 0.047UF	10.00% 16V
C5212	1-164-222-91	CERAMIC CHIP 0.22UF	25V	C5868	1-164-004-11	CERAMIC CHIP 0.1UF	10.00% 25V
C5213	1-126-947-11	ELECT 47UF	20.00% 35V	C5872	1-164-346-11	CERAMIC CHIP 1UF	16V
C5214	1-126-964-11	ELECT 10UF	20.00% 50V	C5873	1-163-251-11	CERAMIC CHIP 100PF	5.00% 50V
C5215	1-162-923-11	CERAMIC CHIP 47PF	5.00% 50V	C5888	1-164-156-11	CERAMIC CHIP 0.1UF	25V
C5216	1-162-927-11	CERAMIC CHIP 100PF	5.00% 50V	C5889	1-126-964-11	ELECT 10UF	20.00% 50V
C5217	1-136-497-81	FILM 0.1UF	5.00% 50V	C5890	1-164-227-11	CERAMIC CHIP 0.022UF	10.00% 25V
C5218	1-162-923-11	CERAMIC CHIP 47PF	5.00% 50V	C5891	1-137-581-11	FILM 0.1UF	5.00% 100V
C5219	1-126-964-11	ELECT 10UF	20.00% 50V	C5892	1-107-826-11	CERAMIC CHIP 0.1UF	10.00% 16V
C5300	1-126-933-11	ELECT 100UF	20.00% 16V	C5893	1-126-947-11	ELECT 47UF	20.00% 35V
C5301	1-126-947-11	ELECT 47UF	20.00% 35V	C5894	1-126-947-11	ELECT 47UF	20.00% 35V
C5302	1-164-222-91	CERAMIC CHIP 0.22UF	25V	C5895	1-164-156-11	CERAMIC CHIP 0.1UF	25V

REF.NO.	PART.NO	DESCRIPTION	REMARK	REF.NO.	PART.NO	DESCRIPTION	REMARK
C5896	1-165-176-11	CERAMIC CHIP 0.047UF	10.00% 16V	C7067	1-126-947-11	ELECT 47UF	20.00% 35V
C5897	1-162-970-11	CERAMIC CHIP 0.01UF	10.00% 25V	C7068	1-164-222-91	CERAMIC CHIP 0.22UF	25V
C5898	1-162-964-11	CERAMIC CHIP 0.001UF	10.00% 50V	C7069	1-162-919-11	CERAMIC CHIP 22PF	5.00% 50V
C5899	1-107-823-11	CERAMIC CHIP 0.47UF	10.00% 16V	C7070	1-162-919-11	CERAMIC CHIP 22PF	5.00% 50V
C6200	1-126-933-11	ELECT 100UF	20.00% 16V	C7071	1-162-919-11	CERAMIC CHIP 22PF	5.00% 50V
C6201	1-126-935-11	ELECT 470UF	20.00% 16V	< COATING LEAD >			
C6202	1-126-933-11	ELECT 100UF	20.00% 16V	CLP6	* 4-042-408-02	PIN(45), WIRE	
C6203	1-126-925-91	ELECT 470UF	20.00% 10V	< CONNECTOR >			
C6204	1-126-933-11	ELECT 100UF	20.00% 16V	CN0101	* 1-823-330-11	CONNECTOR, BOARD TO BOARD 40P	
C6205	1-126-925-91	ELECT 470UF	20.00% 10V	CN0102	* 1-564-520-11	PLUG, CONNECTOR 5P	
C6206	1-126-933-11	ELECT 100UF	20.00% 16V	CN0103	* 1-817-035-61	PLUG, CONNECTOR 4P	
C6207	1-126-933-11	ELECT 100UF	20.00% 16V	CN1000	* 1-417-319-11	CONNECTOR (SQUARE TYPE) 21P	
C6208	1-126-933-11	ELECT 100UF	20.00% 16V	CN1001	* 1-766-296-41	CONNECTOR, DUAL SCART	
C6209	1-126-933-11	ELECT 100UF	20.00% 16V	CN2000	* 1-564-512-11	PLUG, CONNECTOR 9P	
C6210	1-126-935-11	ELECT 470UF	20.00% 16V	CN2500	* 1-816-974-51	PLUG, CONNECTOR 3P	
C6211	1-126-947-11	ELECT 47UF	20.00% 35V	CN2501	* 1-564-507-11	PLUG, CONNECTOR 4P	
C6212	1-126-933-11	ELECT 100UF	20.00% 16V	CN2502	* 1-816-977-51	PLUG, CONNECTOR 6P	
C6213	1-126-933-11	ELECT 100UF	20.00% 16V	CN5002	* 1-816-984-71	PLUG, CONNECTOR 7P	
C6214	1-126-933-11	ELECT 100UF	20.00% 16V	CN5100	* 1-816-974-51	PLUG, CONNECTOR 3P	
C7002	1-126-947-11	ELECT 47UF	20.00% 35V	CN5200	* 1-564-506-11	PLUG, CONNECTOR 3P	
C7004	1-164-222-91	CERAMIC CHIP 0.22UF	25V	CN5801	1-764-333-11	PIN, CONNECTOR(PCB) (V TYPE)10P	
C7008	1-162-919-11	CERAMIC CHIP 22PF	5.00% 50V	CN6200	* 1-564-507-11	PLUG, CONNECTOR 4P	
C7016	1-107-823-11	CERAMIC CHIP 0.47UF	10.00% 16V	CN6202	* 1-564-516-11	PLUG, CONNECTOR 13P	
C7018	1-164-004-11	CERAMIC CHIP 0.1UF	10.00% 25V	CN6203	1-695-915-11	TAB (CONTACT)	
C7019	1-164-004-11	CERAMIC CHIP 0.1UF	10.00% 25V	CN7000	* 1-817-044-81	PLUG, CONNECTOR 7P	
C7020	1-164-004-11	CERAMIC CHIP 0.1UF	10.00% 25V	CN7001	* 1-564-512-11	PLUG, CONNECTOR 9P	
C7021	1-164-004-11	CERAMIC CHIP 0.1UF	10.00% 25V	CN8001	1-766-281-11	PIN, CONNECTOR (PC BOARD) 8P	
C7022	1-164-004-11	CERAMIC CHIP 0.1UF	10.00% 25V	< DIODE >			
C7023	1-164-004-11	CERAMIC CHIP 0.1UF	10.00% 25V	D0101	8-719-921-88	DIODE MTZJ-13B	
C7030	1-164-004-11	CERAMIC CHIP 0.1UF	10.00% 25V	D0104	8-719-109-89	DIODE RD5.6ESE2	
C7031	1-164-004-11	CERAMIC CHIP 0.1UF	10.00% 25V	D0110	8-719-109-89	DIODE RD5.6ESE2	
C7032	1-164-004-11	CERAMIC CHIP 0.1UF	10.00% 25V	D0111	8-719-929-15	DIODE HZS9.1NE2	
C7038	1-107-823-11	CERAMIC CHIP 0.47UF	10.00% 16V	D0112	8-719-921-88	DIODE MTZJ-13B	
C7039	1-162-966-11	CERAMIC CHIP 0.0022UF	10.00% 50V	D0113	8-719-921-88	DIODE MTZJ-13B	
C7050	1-162-927-11	CERAMIC CHIP 100PF	5.00% 50V	D1002	8-719-050-38	DIODE M1MA152WK-T1	
C7051	1-164-004-11	CERAMIC CHIP 0.1UF	10.00% 25V	D2014	8-719-929-15	DIODE HZS9.1NE2	
C7052	1-164-004-11	CERAMIC CHIP 0.1UF	10.00% 25V	D2015	8-719-929-15	DIODE HZS9.1NE2	
C7053	1-164-004-11	CERAMIC CHIP 0.1UF	10.00% 25V	D2016	8-719-050-38	DIODE M1MA152WK-T1	
C7054	1-126-963-11	ELECT 4.7UF	20.00% 50V	D2018	8-719-929-15	DIODE HZS9.1NE2	
C7055	1-164-222-91	CERAMIC CHIP 0.22UF	25V	D2019	8-719-929-15	DIODE HZS9.1NE2	
C7056	1-126-933-11	ELECT 100UF	20.00% 16V	D2500	8-719-050-38	DIODE M1MA152WK-T1	
C7057	1-164-222-91	CERAMIC CHIP 0.22UF	25V	D2502	8-719-109-89	DIODE RD5.6ESE2	
C7058	1-126-933-11	ELECT 100UF	20.00% 16V	D2503	8-719-050-38	DIODE M1MA152WK-T1	
C7059	1-126-933-11	ELECT 100UF	20.00% 16V	D3001	8-719-929-15	DIODE HZS9.1NE2	
C7060	1-164-222-91	CERAMIC CHIP 0.22UF	25V	D3003	8-719-929-15	DIODE HZS9.1NE2	
C7061	1-164-004-11	CERAMIC CHIP 0.1UF	10.00% 25V	D3005	8-719-929-15	DIODE HZS9.1NE2	
C7062	1-164-004-11	CERAMIC CHIP 0.1UF	10.00% 25V	D3007	8-719-109-89	DIODE RD5.6ESE2	
C7063	1-164-004-11	CERAMIC CHIP 0.1UF	10.00% 25V				
C7064	1-126-947-11	ELECT 47UF	20.00% 35V				
C7065	1-164-222-91	CERAMIC CHIP 0.22UF	25V				

REF.NO.	PART.NO	DESCRIPTION	REMARK	REF.NO.	PART.NO	DESCRIPTION	REMARK
D3008	8-719-109-89	DIODE RD5.6ESB2				< IC >	
D3009	8-719-929-15	DIODE HZS9.1NB2					
D3011	8-719-929-15	DIODE HZS9.1NB2		IC1001	6-704-747-01	IC TDA9886TS/V4B	
D3013	8-719-929-15	DIODE HZS9.1NB2		IC2000	6-701-031-11	IC MSP3411G-QA-B11	
D3015	8-719-929-15	DIODE HZS9.1NB2		IC2001	8-759-100-96	IC UPC4558G2	
				IC2500	8-759-831-56	IC TDA7497	
D3017	8-719-109-89	DIODE RD5.6ESB2		IC3100	6-700-504-01	IC SDA9488X-B23GEG	
D3018	8-719-109-89	DIODE RD5.6ESB2					
D3019	8-719-929-15	DIODE HZS9.1NB2		IC3200	6-706-076-01	IC VSP9402A-VK-B13G	
D3021	8-719-929-15	DIODE HZS9.1NB2		IC5103	8-752-072-94	IC CXA1875AM-T4	
D3023	8-719-109-89	DIODE RD5.6ESB2		IC5104	8-759-803-42	IC LA6500-FA	
				IC5200	8-759-595-52	IC CXA8070AP	
D3024	8-719-929-15	DIODE HZS9.1NB2		IC5201	6-701-046-01	IC LM318N	
D3026	8-719-929-15	DIODE HZS9.1NB2					
D3028	8-719-929-15	DIODE HZS9.1NB2		IC5300	8-759-008-70	IC LM358N	
D3201	8-719-109-89	DIODE RD5.6ESB2		IC5301	8-759-659-67	IC LA6393DLL	
D5103	8-719-110-86	DIODE RD39ESB		IC5302	8-759-659-67	IC LA6393DLL	
				IC5400	8-759-696-71	IC STV9379A	
D5104	8-719-109-89	DIODE RD5.6ESB2		IC6200	8-759-648-19	IC L7809CV/LSY	
D5200	8-719-991-33	DIODE 1SS133T-77					
D5201	1-535-303-00	LEAD, JUMPER (5.0MM)		IC6201	8-759-648-20	IC L7805CV/LSY	
D5202	8-719-050-38	DIODE M1MA152WK-T1		IC6202	8-759-445-59	IC BA033T	
D5300	8-719-081-97	DIODE MMDL914T1		IC6203	8-759-098-24	IC PQ30RV11	
				IC6204	8-759-591-02	IC L78L33ABZ-AP	
D5303	8-719-081-97	DIODE MMDL914T1		IC6205	8-759-394-35	IC BA12T	
D5304	8-719-081-97	DIODE MMDL914T1					
D5305	8-719-991-33	DIODE 1SS133T-77		IC6206	8-759-991-41	IC LM78L05ACZ	
D5306	8-719-302-43	DIODE EL1Z		IC7002	8-752-090-88	IC CXA2100AQ-TL	
D5307	8-719-987-87	DIODE ERA85-009					
						< SOCKET >	
D5308	8-719-081-97	DIODE MMDL914T1		J2000	1-784-632-11	JACK, PIN 2P	
D5309	8-719-081-97	DIODE MMDL914T1					
D5400	8-719-982-03	DIODE MTZJ-3.6A				< COIL >	
D5401	8-719-050-38	DIODE M1MA152WK-T1		L1001	1-412-987-31	INDUCTOR	4.7UH
D5404	8-719-110-41	DIODE RD15ESB2		L1002	1-412-987-31	INDUCTOR	4.7UH
				L1003	1-414-934-21	INDUCTOR	10UH
D5405	8-719-908-03	DIODE GP08D		L1004	1-216-864-11	SHORT CHIP	0
D5406	8-719-081-97	DIODE MMDL914T1		L1005	1-216-864-11	SHORT CHIP	0
D5407	8-719-081-97	DIODE MMDL914T1					
D5804	8-719-109-89	DIODE RD5.6ESB2		L1009	1-216-864-11	SHORT CHIP	0
D5807	8-719-929-15	DIODE HZS9.1NB2		L1010	1-216-864-11	SHORT CHIP	0
				L1011	1-216-864-11	SHORT CHIP	0
D5809	8-719-050-38	DIODE M1MA152WK-T1		L1012	1-216-864-11	SHORT CHIP	0
D5811	8-719-081-97	DIODE MMDL914T1		L1013	1-216-864-11	SHORT CHIP	0
D5812	8-719-081-97	DIODE MMDL914T1					
D5813	8-719-081-97	DIODE MMDL914T1		L2000	1-414-934-21	INDUCTOR	10UH
D5814	1-216-295-91	SHORT CHIP	0	L2001	1-414-934-21	INDUCTOR	10UH
				L2007	1-408-602-31	INDUCTOR	8.2UH
D6200	8-719-063-70	DIODE D1NL20U		L2008	1-216-295-91	SHORT CHIP	0
D7004	8-719-929-15	DIODE HZS9.1NB2		L2009	1-216-295-91	SHORT CHIP	0
		< FERRITE BEAD >		L2010	1-414-928-21	INDUCTOR	1UH
FB3001	1-414-760-21	FERRITE	0UH	L2012	1-414-934-21	INDUCTOR	10UH
				L2013	1-414-928-21	INDUCTOR	1UH
		< FILTER >		L2014	1-408-602-31	INDUCTOR	8.2UH
FL2000	1-239-803-11	FILTER, EMI		L2500	1-535-303-00	LEAD, JUMPER (5.0MM)	

Note : The components identified by shading and marked Δ are critical for safety. Replace only with the part numbers specified in the parts list.

A

REF.NO.	PART.NO	DESCRIPTION	REMARK	REF.NO.	PART.NO	DESCRIPTION	REMARK
L2501	1-535-303-00	LEAD, JUMPER (5.0MM)		Q2002	8-729-010-29	TRANSISTOR MSD601-RST1	
L3000	1-216-295-91	SHORT CHIP 0		Q2003	8-729-010-29	TRANSISTOR MSD601-RST1	
L3004	1-216-295-91	SHORT CHIP 0		Q2004	8-729-010-29	TRANSISTOR MSD601-RST1	
L3005	1-216-295-91	SHORT CHIP 0		Q2005	8-729-010-29	TRANSISTOR MSD601-RST1	
L3006	1-216-295-91	SHORT CHIP 0		Q2501	8-729-010-29	TRANSISTOR MSD601-RST1	
L3007	1-216-295-91	SHORT CHIP 0		Q2502	8-729-010-29	TRANSISTOR MSD601-RST1	
L3008	1-216-295-91	SHORT CHIP 0		Q2503	8-729-010-29	TRANSISTOR MSD601-RST1	
L3009	1-216-295-91	SHORT CHIP 0		Q2504	8-729-010-05	TRANSISTOR MSB709-RT1	
L3010	1-216-295-91	SHORT CHIP 0		Q3200	8-729-010-29	TRANSISTOR MSD601-RST1	
L3011	1-216-295-91	SHORT CHIP 0		Q3201	8-729-010-29	TRANSISTOR MSD601-RST1	
L3012	1-216-295-91	SHORT CHIP 0		Q3202	8-729-010-05	TRANSISTOR MSB709-RT1	
L3105	1-412-006-31	INDUCTOR 10UH		Q3204	8-729-010-05	TRANSISTOR MSB709-RT1	
L3106	1-412-006-31	INDUCTOR 10UH		Q3300	8-729-010-05	TRANSISTOR MSB709-RT1	
L3107	1-412-006-31	INDUCTOR 10UH		Q3301	8-729-010-05	TRANSISTOR MSB709-RT1	
L3200	1-412-006-31	INDUCTOR 10UH		Q3302	8-729-010-05	TRANSISTOR MSB709-RT1	
L3202	1-412-006-31	INDUCTOR 10UH		Q3500	8-729-028-28	TRANSISTOR 2SK2036 (TE85L)	
L3203	1-412-006-31	INDUCTOR 10UH		Q3501	8-729-028-28	TRANSISTOR 2SK2036 (TE85L)	
L3206	1-412-006-31	INDUCTOR 10UH		Q5101	8-729-010-29	TRANSISTOR MSD601-RST1	
L3208	1-412-006-31	INDUCTOR 10UH		Q5200	8-729-010-29	TRANSISTOR MSD601-RST1	
L3209	1-216-864-11	SHORT CHIP 0		Q5201	8-729-010-29	TRANSISTOR MSD601-RST1	
L3300	1-412-006-31	INDUCTOR 10UH		Q5202	8-729-045-04	TRANSISTOR 2SC5511	
L5300	1-406-989-21	INDUCTOR 10MH		Q5203	8-729-044-59	TRANSISTOR 2SA1837 (LBS2SONY)	
L5301	1-406-989-21	INDUCTOR 10MH		Q5204	8-729-010-05	TRANSISTOR MSB709-RT1	
L5400	1-412-524-11	INDUCTOR 8.2UH		Q5205	8-729-010-05	TRANSISTOR MSB709-RT1	
L5896	1-216-864-11	SHORT CHIP 0		Q5300	8-729-010-29	TRANSISTOR MSD601-RST1	
L5897	1-216-864-11	SHORT CHIP 0		Q5301	8-729-053-33	TRANSISTOR IRF614-037	
L5898	1-414-934-21	INDUCTOR 10UH		Q5302	8-729-140-97	TRANSISTOR 2SE734-34	
L5899	1-414-934-21	INDUCTOR 10UH		Q5303	8-729-010-29	TRANSISTOR MSD601-RST1	
L7001	1-414-934-21	INDUCTOR 10UH		Q5304	8-729-010-29	TRANSISTOR MSD601-RST1	
L7009	1-414-934-21	INDUCTOR 10UH		Q5305	8-729-119-78	TRANSISTOR 2SC2785-HFE	
L7010	1-414-934-21	INDUCTOR 10UH		Q5306	8-729-140-97	TRANSISTOR 2SE734-34	
L7011	1-414-934-21	INDUCTOR 10UH		Q5400	8-729-010-29	TRANSISTOR MSD601-RST1	
L7012	1-414-934-21	INDUCTOR 10UH		Q5401	8-729-421-19	TRANSISTOR UN2213	
				Q5402	8-729-010-05	TRANSISTOR MSB709-RT1	
				Q5403	8-729-421-19	TRANSISTOR UN2213	
				Q5404	8-729-926-76	TRANSISTOR IRF620	
PS2501 Δ	1-533-597-31	IC LINK 5A 90V		Q5813	8-729-421-19	TRANSISTOR UN2213	
				Q5814	8-729-010-05	TRANSISTOR MSB709-RT1	
				Q5815	8-729-010-29	TRANSISTOR MSD601-RST1	
				Q5816	8-729-010-05	TRANSISTOR MSB709-RT1	
Q1000	8-729-010-05	TRANSISTOR MSB709-RT1		Q6201	8-729-140-97	TRANSISTOR 2SE734-34	
Q1001	8-729-010-29	TRANSISTOR MSD601-RST1		Q7003	8-729-010-29	TRANSISTOR MSD601-RST1	
Q1002	8-729-421-19	TRANSISTOR UN2213		Q7009	8-729-010-05	TRANSISTOR MSB709-RT1	
Q1003	8-729-421-19	TRANSISTOR UN2213		Q7011	8-729-010-05	TRANSISTOR MSB709-RT1	
Q1004	8-729-422-33	TRANSISTOR 2SD601A-Q-TX		Q7012	8-729-010-05	TRANSISTOR MSB709-RT1	
Q1005	8-729-421-19	TRANSISTOR UN2213		Q7013	8-729-010-29	TRANSISTOR MSD601-RST1	
Q1006	8-729-010-05	TRANSISTOR MSB709-RT1		Q7014	8-729-010-05	TRANSISTOR MSB709-RT1	
Q1008	8-729-421-19	TRANSISTOR UN2213		Q7015	8-729-010-05	TRANSISTOR MSB709-RT1	
Q1009	8-729-010-05	TRANSISTOR MSB709-RT1		Q7016	8-729-010-29	TRANSISTOR MSD601-RST1	
Q2000	8-729-010-29	TRANSISTOR MSD601-RST1		Q7017	8-729-010-05	TRANSISTOR MSB709-RT1	
Q2001	8-729-010-29	TRANSISTOR MSD601-RST1					

< PROTECTOR MODULE >

< TRANSISTOR >

REF.NO.	PART.NO	DESCRIPTION	REMARK	REF.NO.	PART.NO	DESCRIPTION	REMARK
Q7018	8-729-010-05	TRANSISTOR MSB709-RT1		R1037	1-216-829-11	METAL CHIP 4.7K 5%	1/10W
Q7019	8-729-010-29	TRANSISTOR MSD601-RST1		R1038	1-216-833-11	METAL CHIP 10K 5%	1/10W
		< RESISTOR >		R1039	1-216-801-11	METAL CHIP 22 5%	1/10W
JR105	1-216-295-91	SHORT CHIP 0		R1041	1-216-812-11	METAL CHIP 180 5%	1/10W
JR121	1-216-864-11	SHORT CHIP 0		R1042	1-216-821-11	METAL CHIP 1K 5%	1/10W
JR123	1-216-864-11	SHORT CHIP 0		R1045	1-216-864-11	SHORT CHIP 0	
JR134	1-216-295-91	SHORT CHIP 0		R1046	1-216-809-11	METAL CHIP 100 5%	1/10W
JR1003	1-216-864-11	SHORT CHIP 0		R1047	1-216-817-11	METAL CHIP 470 5%	1/10W
JR1004	1-216-864-11	SHORT CHIP 0		R1048	1-216-834-11	METAL CHIP 12K 5%	1/10W
JR1009	1-216-864-11	SHORT CHIP 0		R1050	1-216-809-11	METAL CHIP 100 5%	1/10W
JR2000	1-216-295-91	SHORT CHIP 0		R1051	1-216-809-11	METAL CHIP 100 5%	1/10W
R0101	1-216-833-11	METAL CHIP 10K 5%	1/10W	R1052	1-216-845-11	METAL CHIP 100K 5%	1/10W
R0102	1-216-827-11	METAL CHIP 3.3K 5%	1/10W	R2009	1-216-817-11	METAL CHIP 470 5%	1/10W
R0103	1-216-073-91	RES-CHIP 10K 5%	1/10W	R2010	1-216-817-11	METAL CHIP 470 5%	1/10W
R0104	1-216-827-11	METAL CHIP 3.3K 5%	1/10W	R2011	1-216-049-11	RES-CHIP 1K 5%	1/10W
R0105	1-216-025-11	RES-CHIP 100 5%	1/10W	R2014	1-216-049-11	RES-CHIP 1K 5%	1/10W
R0107	1-216-025-11	RES-CHIP 100 5%	1/10W	R2015	1-216-295-91	SHORT CHIP 0	
R1000	1-216-049-11	RES-CHIP 1K 5%	1/10W	R2017	1-216-853-11	METAL CHIP 470K 5%	1/10W
R1001	1-216-001-00	RES-CHIP 10 5%	1/10W	R2018	1-216-295-91	SHORT CHIP 0	
R1002	1-216-821-11	METAL CHIP 1K 5%	1/10W	R2020	1-216-853-11	METAL CHIP 470K 5%	1/10W
R1004	1-216-864-11	SHORT CHIP 0		R2023	1-216-853-11	METAL CHIP 470K 5%	1/10W
R1005	1-216-049-11	RES-CHIP 1K 5%	1/10W	R2026	1-216-853-11	METAL CHIP 470K 5%	1/10W
R1006	1-216-051-00	RES-CHIP 1.2K 5%	1/10W	R2029	1-216-853-11	METAL CHIP 470K 5%	1/10W
R1007	1-216-809-11	METAL CHIP 100 5%	1/10W	R2032	1-216-853-11	METAL CHIP 470K 5%	1/10W
R1008	1-216-864-11	SHORT CHIP 0		R2035	1-216-853-11	METAL CHIP 470K 5%	1/10W
R1009	1-216-837-11	METAL CHIP 22K 5%	1/10W	R2038	1-216-853-11	METAL CHIP 470K 5%	1/10W
R1011	1-216-825-11	METAL CHIP 2.2K 5%	1/10W	R2041	1-216-853-11	METAL CHIP 470K 5%	1/10W
R1013	1-216-825-11	METAL CHIP 2.2K 5%	1/10W	R2042	1-216-829-11	METAL CHIP 4.7K 5%	1/10W
R1014	1-216-825-11	METAL CHIP 2.2K 5%	1/10W	R2043	1-216-829-11	METAL CHIP 4.7K 5%	1/10W
R1016	1-216-817-11	METAL CHIP 470 5%	1/10W	R2044	1-216-853-11	METAL CHIP 470K 5%	1/10W
R1018	1-216-830-11	METAL CHIP 5.6K 5%	1/10W	R2047	1-216-853-11	METAL CHIP 470K 5%	1/10W
R1019	1-216-827-11	METAL CHIP 3.3K 5%	1/10W	R2048	1-216-837-11	METAL CHIP 22K 5%	1/10W
R1020	1-216-811-11	METAL CHIP 150 5%	1/10W	R2050	1-216-845-11	METAL CHIP 100K 5%	1/10W
R1021	1-216-833-11	METAL CHIP 10K 5%	1/10W	R2051	1-216-049-11	RES-CHIP 1K 5%	1/10W
R1022	1-216-839-11	METAL CHIP 33K 5%	1/10W	R2052	1-216-837-11	METAL CHIP 22K 5%	1/10W
R1023	1-216-849-11	METAL CHIP 220K 5%	1/10W	R2053	1-216-817-11	METAL CHIP 470 5%	1/10W
R1024	1-216-839-11	METAL CHIP 33K 5%	1/10W	R2054	1-216-049-11	RES-CHIP 1K 5%	1/10W
R1025	1-216-837-11	METAL CHIP 22K 5%	1/10W	R2055	1-216-049-11	RES-CHIP 1K 5%	1/10W
R1026	1-216-817-11	METAL CHIP 470 5%	1/10W	R2056	1-216-815-11	METAL CHIP 330 5%	1/10W
R1027	1-216-824-11	METAL CHIP 1.8K 5%	1/10W	R2057	1-216-025-11	RES-CHIP 100 5%	1/10W
R1028	1-216-813-11	METAL CHIP 220 5%	1/10W	R2058	1-216-025-11	RES-CHIP 100 5%	1/10W
R1029	1-216-809-11	METAL CHIP 100 5%	1/10W	R2059	1-216-829-11	METAL CHIP 4.7K 5%	1/10W
R1030	1-216-819-11	METAL CHIP 680 5%	1/10W	R2060	1-216-829-11	METAL CHIP 4.7K 5%	1/10W
R1032	1-216-822-11	METAL CHIP 1.2K 5%	1/10W	R2061	1-216-829-11	METAL CHIP 4.7K 5%	1/10W
R1033	1-218-867-11	METAL CHIP 6.8K 0.5%	1/10W	R2062	1-216-829-11	METAL CHIP 4.7K 5%	1/10W
R1034	1-216-807-11	METAL CHIP 68 5%	1/10W	R2063	1-216-829-11	METAL CHIP 4.7K 5%	1/10W
R1035	1-216-807-11	METAL CHIP 68 5%	1/10W	R2064	1-249-425-11	CARBON 4.7K 5%	1/4W
R1036	1-216-814-11	METAL CHIP 270 5%	1/10W	R2065	1-216-837-11	METAL CHIP 22K 5%	1/10W
				R2066	1-216-829-11	METAL CHIP 4.7K 5%	1/10W
				R2067	1-216-829-11	METAL CHIP 4.7K 5%	1/10W

REF.NO.	PART.NO	DESCRIPTION	REMARK			REF.NO.	PART.NO	DESCRIPTION	REMARK		
R2068	1-216-049-11	RES-CHIP	1K	5%	1/10W	R2930	1-216-295-91	SHORT CHIP	0		
R2069	1-216-837-11	METAL CHIP	22K	5%	1/10W	R2933	1-216-295-91	SHORT CHIP	0		
R2070	1-216-833-11	METAL CHIP	10K	5%	1/10W	R2936	1-216-295-91	SHORT CHIP	0		
R2071	1-216-839-11	METAL CHIP	33K	5%	1/10W	R2939	1-216-295-91	SHORT CHIP	0		
R2072	1-216-049-11	RES-CHIP	1K	5%	1/10W	R2942	1-216-295-91	SHORT CHIP	0		
R2073	1-216-049-11	RES-CHIP	1K	5%	1/10W	R2945	1-216-295-91	SHORT CHIP	0		
R2074	1-216-837-11	METAL CHIP	22K	5%	1/10W	R3000	1-216-025-11	RES-CHIP	100	5%	1/10W
R2075	1-216-833-11	METAL CHIP	10K	5%	1/10W	R3001	1-216-022-00	RES-CHIP	75	5%	1/10W
R2076	1-216-839-11	METAL CHIP	33K	5%	1/10W	R3009	1-216-025-11	RES-CHIP	100	5%	1/10W
R2077	1-216-049-11	RES-CHIP	1K	5%	1/10W	R3010	1-216-022-00	RES-CHIP	75	5%	1/10W
R2078	1-216-025-11	RES-CHIP	100	5%	1/10W	R3011	1-216-025-11	RES-CHIP	100	5%	1/10W
R2079	1-216-049-11	RES-CHIP	1K	5%	1/10W	R3012	1-216-022-00	RES-CHIP	75	5%	1/10W
R2080	1-218-867-11	METAL CHIP	6.8K	0.5%	1/10W	R3013	1-216-025-11	RES-CHIP	100	5%	1/10W
R2081	1-216-833-11	METAL CHIP	10K	5%	1/10W	R3014	1-216-022-00	RES-CHIP	75	5%	1/10W
R2082	1-216-031-00	RES-CHIP	180	5%	1/10W	R3015	1-216-022-00	RES-CHIP	75	5%	1/10W
R2083	1-216-817-11	METAL CHIP	470	5%	1/10W	R3016	1-216-025-11	RES-CHIP	100	5%	1/10W
R2084	1-216-837-11	METAL CHIP	22K	5%	1/10W	R3017	1-216-022-00	RES-CHIP	75	5%	1/10W
R2085	1-216-837-11	METAL CHIP	22K	5%	1/10W	R3018	1-216-025-11	RES-CHIP	100	5%	1/10W
R2086	1-216-837-11	METAL CHIP	22K	5%	1/10W	R3019	1-216-022-00	RES-CHIP	75	5%	1/10W
R2087	1-216-837-11	METAL CHIP	22K	5%	1/10W	R3020	1-216-025-11	RES-CHIP	100	5%	1/10W
R2088	1-216-041-00	RES-CHIP	470	5%	1/10W	R3021	1-216-022-00	RES-CHIP	75	5%	1/10W
R2089	1-216-041-00	RES-CHIP	470	5%	1/10W	R3022	1-216-025-11	RES-CHIP	100	5%	1/10W
R2092	1-216-039-00	RES-CHIP	390	5%	1/10W	R3023	1-216-022-00	RES-CHIP	75	5%	1/10W
R2093	1-216-039-00	RES-CHIP	390	5%	1/10W	R3024	1-216-025-11	RES-CHIP	100	5%	1/10W
R2094	1-216-039-00	RES-CHIP	390	5%	1/10W	R3025	1-216-022-00	RES-CHIP	75	5%	1/10W
R2095	1-216-039-00	RES-CHIP	390	5%	1/10W	R3026	1-216-022-00	RES-CHIP	75	5%	1/10W
R2096	1-216-039-00	RES-CHIP	390	5%	1/10W	R3027	1-216-025-11	RES-CHIP	100	5%	1/10W
R2097	1-216-039-00	RES-CHIP	390	5%	1/10W	R3028	1-216-022-00	RES-CHIP	75	5%	1/10W
R2098	1-216-049-11	RES-CHIP	1K	5%	1/10W	R3029	1-216-045-00	RES-CHIP	680	5%	1/10W
R2099	1-216-049-11	RES-CHIP	1K	5%	1/10W	R3030	1-216-022-00	RES-CHIP	75	5%	1/10W
R2500	1-216-073-91	RES-CHIP	10K	5%	1/10W	R3031	1-216-022-00	RES-CHIP	75	5%	1/10W
R2501	1-216-341-11	METAL OXIDE	0.22	5%	1W	R3032	1-216-022-00	RES-CHIP	75	5%	1/10W
R2502	1-208-810-11	METAL CHIP	15K	0.5%	1/10W	R3033	1-216-025-11	RES-CHIP	100	5%	1/10W
R2503	1-208-810-11	METAL CHIP	15K	0.5%	1/10W	R3034	1-216-022-00	RES-CHIP	75	5%	1/10W
R2504	1-216-049-11	RES-CHIP	1K	5%	1/10W	R3035	1-216-025-11	RES-CHIP	100	5%	1/10W
R2507	1-216-837-11	METAL CHIP	22K	5%	1/10W	R3036	1-216-022-00	RES-CHIP	75	5%	1/10W
R2509	1-249-417-11	CARBON	1K	5%	1/4W	R3037	1-216-045-00	RES-CHIP	680	5%	1/10W
R2511	1-216-073-91	RES-CHIP	10K	5%	1/10W	R3104	1-216-295-91	SHORT CHIP	0		
R2516	1-216-081-00	RES-CHIP	22K	5%	1/10W	R3110	1-216-025-11	RES-CHIP	100	5%	1/10W
R2517	1-216-841-11	METAL CHIP	47K	5%	1/10W	R3111	1-216-025-11	RES-CHIP	100	5%	1/10W
R2518	1-216-049-11	RES-CHIP	1K	5%	1/10W	R3112	1-216-295-91	SHORT CHIP	0		
R2519	1-216-833-11	METAL CHIP	10K	5%	1/10W	R3218	1-216-821-11	METAL CHIP	1K	5%	1/10W
R2520	1-216-025-11	RES-CHIP	100	5%	1/10W	R3219	1-216-821-11	METAL CHIP	1K	5%	1/10W
R2524	1-216-833-11	METAL CHIP	10K	5%	1/10W	R3220	1-216-837-11	METAL CHIP	22K	5%	1/10W
R2525	1-216-828-11	METAL CHIP	3.9K	5%	1/10W	R3221	1-216-837-11	METAL CHIP	22K	5%	1/10W
R2912	1-216-295-91	SHORT CHIP	0			R3222	1-216-837-11	METAL CHIP	22K	5%	1/10W
R2914	1-216-853-11	METAL CHIP	470K	5%	1/10W	R3223	1-216-837-11	METAL CHIP	22K	5%	1/10W
R2921	1-216-295-91	SHORT CHIP	0			R3225	1-216-025-11	RES-CHIP	100	5%	1/10W
R2924	1-216-295-91	SHORT CHIP	0			R3226	1-216-025-11	RES-CHIP	100	5%	1/10W
R2927	1-216-295-91	SHORT CHIP	0			R3229	1-216-025-11	RES-CHIP	100	5%	1/10W

REF.NO.	PART.NO	DESCRIPTION	REMARK	REF.NO.	PART.NO	DESCRIPTION	REMARK
R3230	1-216-025-11	RES-CHIP	100 5% 1/10W	R5203	1-216-825-11	METAL CHIP	2.2K 5% 1/10W
R3233	1-216-821-11	METAL CHIP	1K 5% 1/10W	R5204	1-216-809-11	METAL CHIP	100 5% 1/10W
R3234	1-216-821-11	METAL CHIP	1K 5% 1/10W	R5206	1-216-061-91	RES-CHIP	3.3K 5% 1/10W
R3235	1-216-822-11	METAL CHIP	1.2K 5% 1/10W	R5207	1-216-057-00	RES-CHIP	2.2K 5% 1/10W
R3236	1-216-822-11	METAL CHIP	1.2K 5% 1/10W	R5208	1-212-849-00	FUSIBLE	4.7 5% 1/4W
R3237	1-216-797-11	METAL CHIP	10 5% 1/10W	R5209	1-216-809-11	METAL CHIP	100 5% 1/10W
R3238	1-216-797-11	METAL CHIP	10 5% 1/10W	R5210	1-216-845-11	METAL CHIP	100K 5% 1/10W
R3305	1-216-025-11	RES-CHIP	100 5% 1/10W	R5211	1-216-845-11	METAL CHIP	100K 5% 1/10W
R3306	1-216-025-11	RES-CHIP	100 5% 1/10W	R5214	1-208-798-11	METAL CHIP	4.7K 0.5% 1/10W
R3312	1-216-825-11	METAL CHIP	2.2K 5% 1/10W	R5215	1-216-025-11	RES-CHIP	100 5% 1/10W
R3313	1-216-825-11	METAL CHIP	2.2K 5% 1/10W	R5217	1-216-825-11	METAL CHIP	2.2K 5% 1/10W
R3314	1-216-825-11	METAL CHIP	2.2K 5% 1/10W	R5218	1-260-321-51	CARBON	270 5% 1/2W
R3318	1-216-025-11	RES-CHIP	100 5% 1/10W	R5219	1-208-798-11	METAL CHIP	4.7K 0.5% 1/10W
R3319	1-216-025-11	RES-CHIP	100 5% 1/10W	R5220	1-215-886-11	METAL OXIDE	100 5% 2W
R3320	1-216-025-11	RES-CHIP	100 5% 1/10W	R5222	1-218-874-11	METAL CHIP	13K 0.5% 1/10W
R3403	1-216-821-11	METAL CHIP	1K 5% 1/10W	R5223	1-208-814-91	METAL CHIP	22K 0.5% 1/10W
R3500	1-216-834-11	METAL CHIP	12K 5% 1/10W	R5225	1-216-057-00	RES-CHIP	2.2K 5% 1/10W
R3501	1-216-834-11	METAL CHIP	12K 5% 1/10W	R5226	1-212-849-00	FUSIBLE	4.7 5% 1/4W
R3504	1-216-825-11	METAL CHIP	2.2K 5% 1/10W	R5227	1-216-049-11	RES-CHIP	1K 5% 1/10W
R3505	1-216-825-11	METAL CHIP	2.2K 5% 1/10W	R5228	1-216-049-11	RES-CHIP	1K 5% 1/10W
R3603	1-216-295-91	SHORT CHIP	0	R5229	1-216-837-11	METAL CHIP	22K 5% 1/10W
R5118	1-249-413-11	CARBON	470 5% 1/4W	R5230	1-218-873-11	METAL CHIP	12K 0.5% 1/10W
R5119	1-216-840-11	METAL CHIP	39K 5% 1/10W	R5231	1-216-057-00	RES-CHIP	2.2K 5% 1/10W
R5122	1-216-821-11	METAL CHIP	1K 5% 1/10W	R5232	1-216-845-11	METAL CHIP	100K 5% 1/10W
R5125	1-216-836-11	METAL CHIP	18K 5% 1/10W	R5233	1-216-057-00	RES-CHIP	2.2K 5% 1/10W
R5126	1-249-413-11	CARBON	470 5% 1/4W	R5234	1-216-833-11	METAL CHIP	10K 5% 1/10W
R5128	1-216-809-11	METAL CHIP	100 5% 1/10W	R5235	1-216-833-11	METAL CHIP	10K 5% 1/10W
R5129	1-216-809-11	METAL CHIP	100 5% 1/10W	R5237	1-216-049-11	RES-CHIP	1K 5% 1/10W
R5130	1-216-809-11	METAL CHIP	100 5% 1/10W	R5238	1-216-393-00	METAL OXIDE	2.2 5% 3W
R5131	1-216-821-11	METAL CHIP	1K 5% 1/10W	R5239	1-208-848-11	METAL CHIP	560K 0.5% 1/10W
R5132	1-216-809-11	METAL CHIP	100 5% 1/10W	R5241	1-216-841-11	METAL CHIP	47K 5% 1/10W
R5133	1-216-809-11	METAL CHIP	100 5% 1/10W	R5300	1-208-806-11	METAL CHIP	10K 0.5% 1/10W
R5137	1-216-809-11	METAL CHIP	100 5% 1/10W	R5301	1-216-829-11	METAL CHIP	4.7K 5% 1/10W
R5138	1-216-809-11	METAL CHIP	100 5% 1/10W	R5302	1-208-806-11	METAL CHIP	10K 0.5% 1/10W
R5139	1-216-821-11	METAL CHIP	1K 5% 1/10W	R5303	1-216-685-11	METAL CHIP	27K 0.5% 1/10W
R5140	1-216-821-11	METAL CHIP	1K 5% 1/10W	R5304	1-208-806-11	METAL CHIP	10K 0.5% 1/10W
R5141	1-216-833-11	METAL CHIP	10K 5% 1/10W	R5305	1-208-852-11	METAL CHIP	820K 0.5% 1/10W
R5143	1-216-833-11	METAL CHIP	10K 5% 1/10W	R5306	1-208-803-11	METAL CHIP	7.5K 0.5% 1/10W
R5144	1-216-821-11	METAL CHIP	1K 5% 1/10W	R5307	1-216-041-00	RES-CHIP	470 5% 1/10W
R5145	1-216-809-11	METAL CHIP	100 5% 1/10W	R5308	1-216-295-91	SHORT CHIP	0
R5147	1-216-809-11	METAL CHIP	100 5% 1/10W	R5309	1-208-824-11	METAL CHIP	56K 0.5% 1/10W
R5150	1-249-414-11	CARBON	560 5% 1/4W	R5310	1-208-830-11	METAL CHIP	100K 0.5% 1/10W
R5151	1-249-454-11	CARBON	3.9 5% 1/4W	R5311	1-216-045-00	RES-CHIP	680 5% 1/10W
R5152	1-249-413-11	CARBON	470 5% 1/4W	R5312	1-208-832-11	METAL CHIP	120K 0.5% 1/10W
R5153	1-249-393-11	CARBON	10 5% 1/4W	R5314	1-208-840-11	METAL CHIP	270K 0.5% 1/10W
R5154	1-216-833-11	METAL CHIP	10K 5% 1/10W	R5315	1-216-043-91	RES-CHIP	560 5% 1/10W
R5155	1-249-421-11	CARBON	2.2K 5% 1/4W	R5316	1-216-057-00	RES-CHIP	2.2K 5% 1/10W
R5156	1-216-833-11	METAL CHIP	10K 5% 1/10W	R5317	1-216-845-11	METAL CHIP	100K 5% 1/10W
R5157	1-216-829-11	METAL CHIP	4.7K 5% 1/10W	R5318	1-208-806-11	METAL CHIP	10K 0.5% 1/10W
R5201	1-216-061-91	RES-CHIP	3.3K 5% 1/10W	R5319	1-208-840-11	METAL CHIP	270K 0.5% 1/10W

REF.NO.	PART.NO	DESCRIPTION	REMARK	REF.NO.	PART.NO	DESCRIPTION	REMARK
R5320	1-216-833-11	METAL CHIP	10K 5% 1/10W	R5871	1-216-850-11	METAL CHIP	270K 5% 1/10W
R5321	1-216-837-11	METAL CHIP	22K 5% 1/10W	R5872	1-216-073-91	RES-CHIP	10K 5% 1/10W
R5322	1-216-820-11	METAL CHIP	820 5% 1/10W	R5873	1-216-073-91	RES-CHIP	10K 5% 1/10W
R5324	1-208-810-11	METAL CHIP	15K 0.5% 1/10W	R5875	1-216-825-11	METAL CHIP	2.2K 5% 1/10W
R5325	1-208-812-11	METAL CHIP	18K 0.5% 1/10W	R5877	1-216-829-11	METAL CHIP	4.7K 5% 1/10W
R5326	1-216-845-11	METAL CHIP	100K 5% 1/10W	R5878	1-216-817-11	METAL CHIP	470 5% 1/10W
R5327	1-216-472-00	METAL OXIDE	39 5% 3W	R5879	1-216-809-11	METAL CHIP	100 5% 1/10W
R5328	1-216-033-00	RES-CHIP	220 5% 1/10W	R5880	1-216-809-11	METAL CHIP	100 5% 1/10W
R5331	1-216-033-00	RES-CHIP	220 5% 1/10W	R5881	1-216-833-11	METAL CHIP	10K 5% 1/10W
R5332	1-208-806-11	METAL CHIP	10K 0.5% 1/10W	R5882	1-216-833-11	METAL CHIP	10K 5% 1/10W
R5333	1-208-820-11	METAL CHIP	39K 0.5% 1/10W	R5883	1-216-857-11	METAL CHIP	1M 5% 1/10W
R5334	1-208-834-11	METAL CHIP	150K 0.5% 1/10W	R5884	1-216-841-11	METAL CHIP	47K 5% 1/10W
R5335	1-208-818-11	METAL CHIP	33K 0.5% 1/10W	R5885	1-216-809-11	METAL CHIP	100 5% 1/10W
R5336	1-216-057-00	RES-CHIP	2.2K 5% 1/10W	R5887	1-216-809-11	METAL CHIP	100 5% 1/10W
R5337	1-218-867-11	METAL CHIP	6.8K 0.5% 1/10W	R5888	1-216-809-11	METAL CHIP	100 5% 1/10W
R5338	1-249-413-11	CARBON	470 5% 1/4W	R5889	1-208-806-11	METAL CHIP	10K 0.5% 1/10W
R5340	1-216-057-00	RES-CHIP	2.2K 5% 1/10W	R5892	1-216-833-11	METAL CHIP	10K 5% 1/10W
R5341	1-216-089-91	RES-CHIP	47K 5% 1/10W	R5895	1-216-833-11	METAL CHIP	10K 5% 1/10W
R5342	1-208-818-11	METAL CHIP	33K 0.5% 1/10W	R5898	1-216-832-11	METAL CHIP	8.2K 5% 1/10W
R5343	1-208-808-11	METAL CHIP	12K 0.5% 1/10W	R5899	1-216-863-11	METAL CHIP	3.3M 5% 1/10W
R5344	1-208-820-11	METAL CHIP	39K 0.5% 1/10W	R6200	1-218-831-11	METAL CHIP	220 0.5% 1/10W
R5345	1-208-832-11	METAL CHIP	120K 0.5% 1/10W	R6201	1-218-839-11	METAL CHIP	470 0.5% 1/10W
R5346	1-216-849-11	METAL CHIP	220K 5% 1/10W	R6202	1-249-395-11	CARBON	15 5% 1/4W
R5400	1-216-849-11	METAL CHIP	220K 5% 1/10W	R7007	1-216-049-11	RES-CHIP	1K 5% 1/10W
R5401	1-216-837-11	METAL CHIP	22K 5% 1/10W	R7018	1-216-025-11	RES-CHIP	100 5% 1/10W
R5402	1-216-081-00	RES-CHIP	22K 5% 1/10W	R7023	1-216-834-11	METAL CHIP	12K 5% 1/10W
R5403	1-216-829-11	METAL CHIP	4.7K 5% 1/10W	R7034	1-216-025-11	RES-CHIP	100 5% 1/10W
R5404	1-216-829-11	METAL CHIP	4.7K 5% 1/10W	R7035	1-216-025-11	RES-CHIP	100 5% 1/10W
R5405	1-216-829-11	METAL CHIP	4.7K 5% 1/10W	R7048	1-216-025-11	RES-CHIP	100 5% 1/10W
R5407	1-216-857-11	METAL CHIP	1M 5% 1/10W	R7050	1-216-833-11	METAL CHIP	10K 5% 1/10W
R5408	1-216-825-11	METAL CHIP	2.2K 5% 1/10W	R7051	1-216-025-11	RES-CHIP	100 5% 1/10W
R5409	1-208-802-11	METAL CHIP	6.8K 0.5% 1/10W	R7052	1-216-025-11	RES-CHIP	100 5% 1/10W
R5410	1-208-798-11	METAL CHIP	4.7K 0.5% 1/10W	R7053	1-216-049-11	RES-CHIP	1K 5% 1/10W
R5411	1-216-061-91	RES-CHIP	3.3K 5% 1/10W	R7054	1-216-847-11	METAL CHIP	150K 5% 1/10W
R5413	1-208-802-11	METAL CHIP	6.8K 0.5% 1/10W	R7056	1-218-867-11	METAL CHIP	6.8K 0.5% 1/10W
R5414	1-249-383-11	CARBON	1.5 5% 1/4W	R7057	1-216-842-11	METAL CHIP	56K 5% 1/10W
R5415	1-249-389-11	CARBON	4.7 5% 1/4W	R7058	1-216-049-11	RES-CHIP	1K 5% 1/10W
R5416	1-215-888-00	METAL OXIDE	220 5% 2W	R7065	1-216-821-11	METAL CHIP	1K 5% 1/10W
R5417	1-208-798-11	METAL CHIP	4.7K 0.5% 1/10W	R7066	1-216-809-11	METAL CHIP	100 5% 1/10W
R5420	1-214-798-21	METAL	1.8 1% 1/2W	R7067	1-216-295-91	SHORT CHIP	0
R5421	1-214-798-21	METAL	1.8 1% 1/2W	R7068	1-218-877-11	METAL CHIP	18K 0.5% 1/10W
R5803	1-216-861-11	METAL CHIP	2.2M 5% 1/10W	R7070	1-216-817-11	METAL CHIP	470 5% 1/10W
R5804	1-216-049-11	RES-CHIP	1K 5% 1/10W	R7071	1-216-817-11	METAL CHIP	470 5% 1/10W
R5805	1-216-049-11	RES-CHIP	1K 5% 1/10W	R7072	1-216-817-11	METAL CHIP	470 5% 1/10W
R5806	1-216-089-91	RES-CHIP	47K 5% 1/10W	R7073	1-216-041-00	RES-CHIP	470 5% 1/10W
R5807	1-216-049-11	RES-CHIP	1K 5% 1/10W	R7074	1-216-043-91	RES-CHIP	560 5% 1/10W
R5808	1-216-049-11	RES-CHIP	1K 5% 1/10W	R7075	1-216-817-11	METAL CHIP	470 5% 1/10W
R5809	1-216-073-91	RES-CHIP	10K 5% 1/10W	R7076	1-216-041-00	RES-CHIP	470 5% 1/10W
R5865	1-216-841-11	METAL CHIP	47K 5% 1/10W	R7077	1-216-043-91	RES-CHIP	560 5% 1/10W
R5869	1-216-817-11	METAL CHIP	470 5% 1/10W	R7078	1-216-817-11	METAL CHIP	470 5% 1/10W

REF.NO.	PART.NO	DESCRIPTION	REMARK	REF.NO.	PART.NO	DESCRIPTION	REMARK
R7079	1-216-041-00	RES-CHIP	470 5% 1/10W			< CONNECTOR >	
R7080	1-216-043-91	RES-CHIP	560 5% 1/10W				
R7081	1-216-817-11	METAL CHIP	470 5% 1/10W	CN0001	* 1-793-497-11	CONNECTOR, BOARD TO BOARD 40P	
R7082	1-208-782-11	METAL CHIP	1K 0.5% 1/10W			< DIODE >	
R7087	1-216-833-11	METAL CHIP	10K 5% 1/10W				
R7088	1-208-783-11	METAL CHIP	1.1K 0.5% 1/10W	D0001	6-500-079-01	DIODE BAS40-05E6327	
R7089	1-216-819-11	METAL CHIP	680 5% 1/10W	D0301	8-719-069-56	DIODE UDZSTE-176.2B	
R7090	1-216-819-11	METAL CHIP	680 5% 1/10W			< FERRITE BEAD >	
R7091	1-216-819-11	METAL CHIP	680 5% 1/10W				
R7096	1-216-803-11	METAL CHIP	33 5% 1/10W	FB0003	1-216-295-91	SHORT CHIP	0
R7097	1-216-803-11	METAL CHIP	33 5% 1/10W	FB0004	1-412-006-31	INDUCTOR	10UH
R7098	1-216-803-11	METAL CHIP	33 5% 1/10W	FB0005	1-216-864-11	SHORT CHIP	0
		< RESISTOR VARIABLE >		FB0006	1-216-864-11	SHORT CHIP	0
RV5101	1-238-600-11	RES, ADJ, CARBON 10K		FB0007	1-412-006-31	INDUCTOR	10UH
SF1001	1-795-617-11	SAW FILTER		FB0008	1-216-295-91	SHORT CHIP	0
		< TUNER >		FB0009	1-412-006-31	INDUCTOR	10UH
TU1001	8-598-623-10	TUNER, FSS BTP-AC421		FB0010	1-216-295-91	SHORT CHIP	0
		< CRYSTAL >		FB0011	1-412-006-31	INDUCTOR	10UH
X1001	1-767-704-11	VIBRATOR, CRYSTAL		FB0012	1-216-295-91	SHORT CHIP	0
X2000	1-760-628-11	VIBRATOR, CRYSTAL		FB0015	1-216-864-11	SHORT CHIP	0
X3200	1-781-946-21	VIBRATOR, CRYSTAL		FB0016	1-216-864-11	SHORT CHIP	0
X5800	1-767-127-11	VIBRATOR, CERAMIC		FB0017	1-216-295-91	SHORT CHIP	0
				FB0018	1-216-295-91	SHORT CHIP	0
				FB0019	1-216-295-91	SHORT CHIP	0
				FB0020	1-216-295-91	SHORT CHIP	0
						< IC >	
				IC0001	8-759-699-33	IC M24C16-MN6T(A)	
				IC0002	6-700-503-03	IC SAA5665HL/M1/1402	
				IC0003	8-759-672-39	IC PST573IMT	
				IC0004	8-759-665-11	IC LM393DT	
				IC0005	6-702-395-01	IC K6F2008V2E-YF70T	
						< TRANSISTOR >	
				Q0002	8-729-424-08	TRANSISTOR UN2111	
				Q0003	8-729-424-08	TRANSISTOR UN2111	
				Q0006	8-729-010-29	TRANSISTOR MSD601-RST1	
				Q0007	8-729-027-44	TRANSISTOR DTC114TKA-T146	
				Q0008	8-729-027-44	TRANSISTOR DTC114TKA-T146	
				Q0009	8-729-027-44	TRANSISTOR DTC114TKA-T146	
				Q0010	8-729-027-44	TRANSISTOR DTC114TKA-T146	
				Q0011	8-729-010-29	TRANSISTOR MSD601-RST1	
				Q0012	8-729-424-08	TRANSISTOR UN2111	
				Q0013	8-729-421-22	TRANSISTOR UN2211	
						< RESISTOR >	
C0001	1-107-826-11	CERAMIC CHIP 0.1UF	10.00% 16V	R0001	1-216-045-00	RES-CHIP	680 5% 1/10W
C0002	1-107-826-11	CERAMIC CHIP 0.1UF	10.00% 16V	R0002	1-216-055-00	RES-CHIP	1.8K 5% 1/10W
C0004	1-164-360-11	CERAMIC CHIP 0.1UF	16V	R0003	1-216-295-91	SHORT CHIP	0
C0006	1-126-923-91	ELECT 220UF	20.00% 10V	R0011	1-216-295-91	SHORT CHIP	0
C0007	1-107-826-11	CERAMIC CHIP 0.1UF	10.00% 16V				
C0008	1-107-826-11	CERAMIC CHIP 0.1UF	10.00% 16V				
C0009	1-165-128-11	CERAMIC CHIP 0.22UF	16V				
C0010	1-162-927-11	CERAMIC CHIP 100PF	5.00% 50V				
C0011	1-165-128-11	CERAMIC CHIP 0.22UF	16V				
C0012	1-162-924-11	CERAMIC CHIP 56PF	5.00% 50V				
C0013	1-165-128-11	CERAMIC CHIP 0.22UF	16V				
C0015	1-135-834-91	CERAMIC CHIP 2200000PF	6.3V				
C0016	1-165-128-11	CERAMIC CHIP 0.22UF	16V				
C0017	1-162-924-11	CERAMIC CHIP 56PF	5.00% 50V				
C0019	1-165-128-11	CERAMIC CHIP 0.22UF	16V				
C0025	1-162-962-11	CERAMIC CHIP 470PF	10.00% 50V				
C0026	1-162-962-11	CERAMIC CHIP 470PF	10.00% 50V				
C0027	1-162-962-11	CERAMIC CHIP 470PF	10.00% 50V				
C0028	1-126-947-11	ELECT 47UF	20.00% 35V				

*** A-1634-062-A M Board Complete**

Note : The components identified by shading and marked Δ are critical for safety. Replace only with the part numbers specified in the parts list.

M G

REF.NO.	PART.NO	DESCRIPTION	REMARK	REF.NO.	PART.NO	DESCRIPTION	REMARK
R0014	1-216-081-00	RES-CHIP	22K 5% 1/10W	R0073	1-216-809-11	METAL CHIP	100 5% 1/10W
R0016	1-216-025-11	RES-CHIP	100 5% 1/10W	R0074	1-216-809-11	METAL CHIP	100 5% 1/10W
R0017	1-216-093-91	RES-CHIP	68K 5% 1/10W	R0075	1-216-025-11	RES-CHIP	100 5% 1/10W
R0018	1-216-025-11	RES-CHIP	100 5% 1/10W	R0076	1-216-049-11	RES-CHIP	1K 5% 1/10W
R0019	1-216-073-91	RES-CHIP	10K 5% 1/10W	R0078	1-216-817-11	METAL CHIP	470 5% 1/10W
R0020	1-216-049-11	RES-CHIP	1K 5% 1/10W	R0079	1-216-065-91	RES-CHIP	4.7K 5% 1/10W
R0022	1-216-809-11	METAL CHIP	100 5% 1/10W	R0301	1-216-073-91	RES-CHIP	10K 5% 1/10W
R0023	1-216-097-11	RES-CHIP	100K 5% 1/10W	R0302	1-216-073-91	RES-CHIP	10K 5% 1/10W
R0027	1-216-821-11	METAL CHIP	1K 5% 1/10W	R0303	1-216-836-11	METAL CHIP	18K 5% 1/10W
R0028	1-216-833-11	METAL CHIP	10K 5% 1/10W	R0304	1-218-867-11	METAL CHIP	6.8K 0.5% 1/10W
R0029	1-216-025-11	RES-CHIP	100 5% 1/10W	< CRYSTAL >			
R0030	1-216-025-11	RES-CHIP	100 5% 1/10W	X0001	1-578-774-11	VIBRATOR, CRYSTAL	
R0032	1-216-809-11	METAL CHIP	100 5% 1/10W	* A-1637-024-A G Board Complete			
R0033	1-216-809-11	METAL CHIP	100 5% 1/10W	* A-1637-024-A COMPLETE PC BOARD, G			
R0034	1-218-725-11	METAL CHIP	24K 0.5% 1/10W	4-382-854-01 SCREW (M3X8), P, SW (+)			
R0035	1-216-069-00	RES-CHIP	6.8K 5% 1/10W	< CAPACITOR >			
R0037	1-216-061-91	RES-CHIP	3.3K 5% 1/10W	C6001	Δ 1-165-528-11	MYLAR	0.1UF 10 275V
R0039	1-216-809-11	METAL CHIP	100 5% 1/10W	C6002	Δ 1-165-528-11	MYLAR	0.1UF 10 275V
R0040	1-216-809-11	METAL CHIP	100 5% 1/10W	C6003	Δ 1-119-899-51	CERAMIC	1000PF 10.00% 250V
R0041	1-216-057-00	RES-CHIP	2.2K 5% 1/10W	C6004	Δ 1-119-899-51	CERAMIC	1000PF 10.00% 250V
R0042	1-216-069-00	RES-CHIP	6.8K 5% 1/10W	C6005	1-126-965-91	ELECT	22UF 20.00% 50V
R0043	1-216-803-11	METAL CHIP	33 5% 1/10W	C6006	1-117-753-11	ELECT (BLOCK)	470UF 20.00% 450V
R0044	1-216-025-11	RES-CHIP	100 5% 1/10W	C6007	1-126-964-11	ELECT	10UF 20.00% 50V
R0045	1-216-803-11	METAL CHIP	33 5% 1/10W	C6008	1-126-963-11	ELECT	4.7UF 20.00% 50V
R0046	1-216-803-11	METAL CHIP	33 5% 1/10W	C6010	1-136-497-81	FILM	0.1UF 5.00% 50V
R0047	1-216-810-11	METAL CHIP	120 5% 1/10W	C6011	1-162-964-11	CERAMIC CHIP	0.001UF 10.00% 50V
R0048	1-216-809-11	METAL CHIP	100 5% 1/10W	C6012	Δ 1-104-571-91	CERAMIC	0.0015UF 10.00% 2KV
R0049	1-216-073-91	RES-CHIP	10K 5% 1/10W	C6013	Δ 1-104-571-91	CERAMIC	0.0015UF 10.00% 2KV
R0050	1-216-810-11	METAL CHIP	120 5% 1/10W	C6015	1-115-339-11	CERAMIC CHIP	0.1UF 10.00% 50V
R0051	1-216-835-11	METAL CHIP	15K 5% 1/10W	C6016	Δ 1-104-571-91	CERAMIC	0.0015UF 10.00% 2KV
R0052	1-216-810-11	METAL CHIP	120 5% 1/10W	C6017	Δ 1-104-571-91	CERAMIC	0.0015UF 10.00% 2KV
R0053	1-216-809-11	METAL CHIP	100 5% 1/10W	C6018	1-126-949-11	ELECT	220UF 20.00% 35V
R0054	1-216-809-11	METAL CHIP	100 5% 1/10W	C6020	1-135-946-22	FILM	47000PF 3% 800V
R0055	1-216-809-11	METAL CHIP	100 5% 1/10W	C6021	1-164-645-11	CERAMIC	1000PF 10.00% 500V
R0056	1-216-833-11	METAL CHIP	10K 5% 1/10W	C6022	1-126-963-11	ELECT	4.7UF 20.00% 50V
R0057	1-216-809-11	METAL CHIP	100 5% 1/10W	C6023	1-110-626-11	ELECT	330UF 20.00% 160V
R0058	1-216-823-11	METAL CHIP	1.5K 5% 1/10W	C6024	1-164-625-11	CERAMIC	680PF 10.00% 500V
R0059	1-216-841-11	METAL CHIP	47K 5% 1/10W	C6025	1-164-625-11	CERAMIC	680PF 10.00% 500V
R0060	1-216-833-11	METAL CHIP	10K 5% 1/10W	C6026	1-164-625-11	CERAMIC	680PF 10.00% 500V
R0061	1-216-833-11	METAL CHIP	10K 5% 1/10W	C6027	1-164-625-11	CERAMIC	680PF 10.00% 500V
R0062	1-216-833-11	METAL CHIP	10K 5% 1/10W	C6028	1-128-548-11	ELECT	4700UF 20.00% 25V
R0063	1-216-073-91	RES-CHIP	10K 5% 1/10W	C6029	1-126-939-11	ELECT	10000UF 20.00% 16V
R0065	1-216-073-91	RES-CHIP	10K 5% 1/10W	C6030	1-119-940-51	ELECT	4700UF 20.00% 50V
R0066	1-218-871-11	METAL CHIP	10K 0.5% 1/10W	C6031	1-535-143-71	LEAD, JUMPER (7.5MM)	
R0067	1-216-833-11	METAL CHIP	10K 5% 1/10W	C6032	Δ 1-113-927-11	CERAMIC	0.01UF 250V
R0068	1-216-833-11	METAL CHIP	10K 5% 1/10W	C6033	1-162-964-11	CERAMIC CHIP	0.001UF 10.00% 50V
R0069	1-216-073-91	RES-CHIP	10K 5% 1/10W				
R0070	1-216-025-11	RES-CHIP	100 5% 1/10W				
R0071	1-216-809-11	METAL CHIP	100 5% 1/10W				
R0072	1-216-809-11	METAL CHIP	100 5% 1/10W				

Note : The components identified by shading and marked Δ are critical for safety. Replace only with the part numbers specified in the parts list.

G

REF.NO.	PART.NO	DESCRIPTION	REMARK	REF.NO.	PART.NO	DESCRIPTION	REMARK
C6034	1-162-968-11	CERAMIC CHIP	0.0047UF 10.00% 50V	FB6005	1-535-303-00	LEAD, JUMPER (5.0MM)	
C6035	1-136-497-81	FILM	0.1UF 5.00% 50V	FB6006	1-535-303-00	LEAD, JUMPER (5.0MM)	
C6036	1-136-479-11	FILM	0.001UF 5.00% 100V				
C6037	1-126-947-11	ELECT	47UF 20.00% 35V			< IC >	
C6038	1-164-645-11	CERAMIC	1000PF 10.00% 500V				
C6039	1-125-891-11	CERAMIC CHIP	0.47UF 10.00% 10V	IC6001	8-759-670-30	IC MCZ3001D	
C6040	1-115-340-11	CERAMIC CHIP	0.22UF 10.00% 25V	IC6003	8-749-016-19	IC SE135N-LF4	
C6045	1-115-339-11	CERAMIC CHIP	0.1UF 10.00% 50V			< COIL >	
C6102	1-126-943-11	ELECT	2200UF 20.00% 25V				
C6103	1-126-971-11	ELECT	470UF 20.00% 50V	L6001	1-406-663-21	INDUCTOR	47UH
				L6002	1-412-529-11	INDUCTOR	22UH
C6105	1-126-964-11	ELECT	10UF 20.00% 50V	L6003	1-412-529-11	INDUCTOR	22UH
C6106	1-126-964-11	ELECT	10UF 20.00% 50V	L6004	1-535-303-00	LEAD, JUMPER (5.0MM)	
				L6005	1-535-303-00	LEAD, JUMPER (5.0MM)	
		< CONNECTOR >					
CN6001	Δ * 1-691-291-11	PIN, CONNECTOR (PC BOARD)	5P				
CN6002	Δ * 1-508-786-00	PIN, CONNECTOR (5MM PITCH)	2P				
CN6003	Δ * 1-508-765-00	PIN, CONNECTOR (5MM PITCH)	3P				
CN6004	Δ * 1-691-960-11	PIN, CONNECTOR (PC BOARD)	3P				
CN6005	* 1-564-509-11	PLUG, CONNECTOR	6P			< PHOTOCOUPLER >	
				PH6001	Δ 8-749-016-21	IC TCET1103G	
CN6006	* 1-564-516-11	PLUG, CONNECTOR	13P			< TRANSISTOR >	
CN6008	1-816-981-71	PLUG, CONNECTOR	4P				
		< DIODE >					
D6001	6-500-067-01	DIODE GSIB460L/45		Q6003	8-729-010-29	TRANSISTOR MSD601-RST1	
D6002	8-719-982-26	DIODE MTZJ-33B		Q6005	8-729-029-56	TRANSISTOR DTA144ESA	
D6004	8-719-979-64	DIODE UF4005PKG23		Q6006	6-550-698-01	TRANSISTOR SPA08N50C3-E8152	
D6006	8-719-081-97	DIODE MMDL914T1		Q6007	6-550-698-01	TRANSISTOR SPA08N50C3-E8152	
D6007	8-719-081-97	DIODE MMDL914T1		Q6010	8-729-119-78	TRANSISTOR 2SC2785-HFE	
D6008	8-719-063-70	DIODE D1NL20U		Q6101	8-729-029-56	TRANSISTOR DTA144ESA	
D6009	8-719-110-41	DIODE RD15ESB2		Q6102	8-729-010-29	TRANSISTOR MSD601-RST1	
D6010	8-719-085-24	DIODE FB1U4D7M1-B		Q6103	8-729-029-56	TRANSISTOR DTA144ESA	
D6016	8-719-312-47	DIODE RBA-406B		Q6104	8-729-010-29	TRANSISTOR MSD601-RST1	
D6031	8-719-080-59	DIODE EK19-V0		Q6105	8-729-010-29	TRANSISTOR MSD601-RST1	
						< RESISTOR >	
D6032	8-719-080-59	DIODE EK19-V0		JR6004	1-216-295-91	SHORT CHIP	0
D6033	8-719-022-97	DIODE D2S4MF					
D6034	8-719-022-97	DIODE D2S4MF		R6003	Δ 1-202-933-61	FUSIBLE	0.1 10% 1/2W
D6035	1-535-303-00	LEAD, JUMPER (5.0MM)		R6004	Δ 1-205-998-11	CEMENTED	1 5% 10W
D6036	1-216-295-91	SHORT CHIP	0	R6005	Δ 1-205-998-11	CEMENTED	1 5% 10W
				R6006	Δ 1-205-998-11	CEMENTED	1 5% 10W
D6101	8-719-081-97	DIODE MMDL914T1		R6007	1-243-979-21	METAL OXIDE	0.1 5% 2W
D6102	8-719-511-40	DIODE S1VB40					
D6103	8-719-081-97	DIODE MMDL914T1		R6008	1-243-979-21	METAL OXIDE	0.1 5% 2W
D6104	8-719-081-97	DIODE MMDL914T1		R6009	1-208-810-11	METAL CHIP	15K 0.5% 1/10W
D6105	8-719-081-97	DIODE MMDL914T1		R6010	1-215-481-00	METAL	330K 1% 1/4W
				R6013	Δ 1-218-265-11	METAL	8.2M 5% 1W
D6106	8-719-081-97	DIODE MMDL914T1		R6014	1-215-926-00	METAL OXIDE	33K 5% 3W
D6107	8-719-081-97	DIODE MMDL914T1					
		< FERRITE BEAD >		R6015	1-208-757-11	METAL CHIP	91 0.5% 1/10W
FB6002	1-410-397-21	FERRITE	1.1UH	R6016	1-216-821-11	METAL CHIP	1K 5% 1/10W
FB6003	1-410-397-21	FERRITE	1.1UH	R6017	1-216-833-11	METAL CHIP	10K 5% 1/10W
				R6018	1-260-131-11	CARBON	470K 5% 1/2W
				R6019	1-260-129-11	CARBON	330K 5% 1/2W

Note : The components identified by shading and marked Δ are critical for safety. Replace only with the part numbers specified in the parts list.



REF.NO.	PART.NO	DESCRIPTION	REMARK	REF.NO.	PART.NO	DESCRIPTION	REMARK
R6020	1-216-820-11	METAL CHIP	820 5% 1/10W	* A-1640-432-A D Board Complete			
R6021	1-216-362-11	METAL OXIDE	0.27 5% 2W		4-382-854-01	SCREW (M3X8), P, SW (+)	
R6022	1-216-833-11	METAL CHIP	10K 5% 1/10W		< CAPACITOR >		
R6024	1-216-615-11	METAL CHIP	33 0.5% 1/10W	C8100	1-136-497-81	FILM 0.1UF	5.00% 50V
R6029	1-216-833-11	METAL CHIP	10K 5% 1/10W	C8101	1-136-497-81	FILM 0.1UF	5.00% 50V
R6030	1-216-817-11	METAL CHIP	470 5% 1/10W	C8102	1-136-497-81	FILM 0.1UF	5.00% 50V
R6032	1-249-417-11	CARBON	1K 5% 1/4W	C8103	1-115-416-11	CERAMIC CHIP 0.001UF	5.00% 25V
R6033	1-215-481-00	METAL	330K 1% 1/4W	C8104	1-115-416-11	CERAMIC CHIP 0.001UF	5.00% 25V
R6034	1-249-389-11	CARBON	4.7 5% 1/4W	C8105	1-126-947-11	ELECT 47UF	20.00% 35V
R6035	1-260-083-11	CARBON	47 5% 1/2W	C8106	1-164-315-11	CERAMIC CHIP 470PF	5.00% 50V
R6036	1-216-817-11	METAL CHIP	470 5% 1/10W	C8107	1-208-820-11	METAL CHIP 39K	0.5% 1/10W
R6037	1-249-405-11	CARBON	100 5% 1/4W	C8108	1-162-970-11	CERAMIC CHIP 0.01UF	10.00% 25V
R6038	1-208-830-11	METAL CHIP	100K 0.5% 1/10W	C8109	1-126-947-11	ELECT 47UF	20.00% 35V
R6039	1-208-830-11	METAL CHIP	100K 0.5% 1/10W	C8113	1-162-970-11	CERAMIC CHIP 0.01UF	10.00% 25V
R6040	1-208-814-91	METAL CHIP	22K 0.5% 1/10W	C8114	1-126-964-11	ELECT 10UF	20.00% 50V
R6042	1-216-295-91	SHORT CHIP	0	C8115	1-162-962-11	CERAMIC CHIP 470PF	10.00% 50V
R6045	1-216-639-11	METAL CHIP	330 0.5% 1/10W	C8116	1-115-416-11	CERAMIC CHIP 0.001UF	5.00% 25V
R6047	1-208-842-11	METAL CHIP	330K 0.5% 1/10W	C8117	1-115-416-11	CERAMIC CHIP 0.001UF	5.00% 25V
R6048	1-215-481-00	METAL	330K 1% 1/4W	C8118	1-162-970-11	CERAMIC CHIP 0.01UF	10.00% 25V
R6049	1-208-805-11	METAL CHIP	9.1K 0.5% 1/10W	C8119	1-107-826-11	CERAMIC CHIP 0.1UF	10.00% 16V
R6050	1-208-758-11	METAL CHIP	100 0.5% 1/10W	C8120	1-165-176-11	CERAMIC CHIP 0.047UF	10.00% 16V
R6054	1-216-615-11	METAL CHIP	33 0.5% 1/10W	C8125	1-162-968-11	CERAMIC CHIP 0.0047UF	10.00% 50V
R6056	1-216-295-91	SHORT CHIP	0	C8126	1-165-176-11	CERAMIC CHIP 0.047UF	10.00% 16V
R6057	1-208-798-11	METAL CHIP	4.7K 0.5% 1/10W	C8128	1-162-968-11	CERAMIC CHIP 0.0047UF	10.00% 50V
R6101	1-216-821-11	METAL CHIP	1K 5% 1/10W	C8130	1-164-230-11	CERAMIC CHIP 220PF	5.00% 50V
R6102	1-216-829-11	METAL CHIP	4.7K 5% 1/10W	C8131	1-126-964-11	ELECT 10UF	20.00% 50V
R6103	1-216-821-11	METAL CHIP	1K 5% 1/10W	C8132	1-164-230-11	CERAMIC CHIP 220PF	5.00% 50V
R6104	1-216-821-11	METAL CHIP	1K 5% 1/10W	C8134	1-102-935-00	CERAMIC 2PF	0.25PF 50V
R6105	1-216-821-11	METAL CHIP	1K 5% 1/10W	C8135	1-126-964-11	ELECT 10UF	20.00% 50V
R6106	1-216-829-11	METAL CHIP	4.7K 5% 1/10W	C8136	1-126-964-11	ELECT 10UF	20.00% 50V
R6107	1-216-829-11	METAL CHIP	4.7K 5% 1/10W	C8140	1-164-004-11	CERAMIC CHIP 0.1UF	10.00% 25V
R6108	1-216-821-11	METAL CHIP	1K 5% 1/10W	C8141	1-535-303-00	LEAD, JUMPER (5.0MM)	
R6109	1-216-829-11	METAL CHIP	4.7K 5% 1/10W	C8207	1-165-176-11	CERAMIC CHIP 0.047UF	10.00% 16V
R6110	1-216-821-11	METAL CHIP	1K 5% 1/10W	C8208	1-162-970-11	CERAMIC CHIP 0.01UF	10.00% 25V
< RELAY >				C8209	1-164-315-11	CERAMIC CHIP 470PF	5.00% 50V
RY6001	Δ 1-755-395-11	RELAY (AC POWER)		C8210	1-162-964-11	CERAMIC CHIP 0.001UF	10.00% 50V
RY6002	Δ 1-755-389-11	RELAY (AC POWER)		C8801	1-126-947-11	ELECT 47UF	20.00% 35V
< TRANSFORMER >				C8802	1-126-960-11	ELECT 1UF	20.00% 50V
T6002	Δ 1-437-850-12	(PIT) CONVERTER TRANSFORMER		C8803	1-126-960-11	ELECT 1UF	20.00% 50V
T6003	Δ 1-424-896-11	TRANSFORMER, LINE FILTER		C8804	1-102-114-00	CERAMIC 470PF	10.00% 50V
T6101	Δ 1-437-483-11	TRANSFORMER, STANDBY		C8805	1-102-114-00	CERAMIC 470PF	10.00% 50V
< THERMISTOR >				C8808	1-102-030-00	CERAMIC 330PF	10.00% 500V
TH6002	Δ 1-804-650-11	THERMISTOR, POSITIVE		C8809	1-102-030-00	CERAMIC 330PF	10.00% 500V
				C8810	1-107-368-11	MYLAR 0.047UF	10.00% 200V
				C8811	1-107-368-11	MYLAR 0.047UF	10.00% 200V
				C8812	1-162-131-11	CERAMIC 220PF	10.00% 2KV
				C8813	1-107-444-11	CERAMIC 100PF	5.00% 2KV
				C8814	1-117-640-11	FILM 6800PF	3.00% 1.2KV

REF.NO.	PART.NO	DESCRIPTION	REMARK	REF.NO.	PART.NO	DESCRIPTION	REMARK
C8815	1-117-835-11	FILM	6200PF	3.00%	1.5KV		
C8816	1-162-964-11	CERAMIC CHIP	0.001UF	10.00%	50V		
C8817	1-125-893-11	FILM	680PF	3.00%	1.5KV		
C8818	1-125-893-11	FILM	680PF	3.00%	1.5KV		
C8819	1-125-893-11	FILM	680PF	3.00%	1.5KV		
C8820	1-125-893-11	FILM	680PF	3.00%	1.5KV		
C8824	1-107-846-11	FILM	0.1UF	5.00%	400V		
C8825	1-117-663-11	FILM	0.22UF	5.00%	250V		
C8826	1-115-518-11	FILM	0.47UF	5.00%	250V		
C8827	1-117-660-21	FILM	0.12UF	5.00%	250V		
C8828	1-127-681-11	FILM	10000PF	2%	100V		
C8829	1-127-680-11	FILM	4700PF	2%	100V		
C8830	1-107-655-11	ELECT	47UF	20.00%	250V		
C8831	1-102-228-00	CERAMIC	470PF	10.00%	500V		
C8832	1-126-941-11	ELECT	470UF	20.00%	25V		
C8833	1-126-941-11	ELECT	470UF	20.00%	25V		
C8834	1-102-228-00	CERAMIC	470PF	10.00%	500V		
C8835	1-102-228-00	CERAMIC	470PF	10.00%	500V		
C8836	1-123-024-21	ELECT	33UF		160V		
C8837	1-106-375-12	MYLAR	0.022UF	5.00%	200V		
C8840	1-165-176-11	CERAMIC CHIP	0.047UF	10.00%	16V		
C8841	1-126-947-11	ELECT	47UF	20.00%	35V		
C8844	1-115-513-21	FILM	0.18UF	5.00%	250V		
C8851	1-162-131-11	CERAMIC	220PF	10.00%	2KV		
C8852	1-162-129-00	CERAMIC	150PF	10.00%	2KV		
C8853	1-129-898-00	FILM	0.0022UF	5.00%	630V		
C8855	1-136-205-11	MYLAR	0.022UF	5.00%	630V		
C8856	1-102-030-00	CERAMIC	330PF	10.00%	500V		
C8860	1-162-964-11	CERAMIC CHIP	0.001UF	10.00%	50V		
C8861	1-162-927-11	CERAMIC CHIP	100PF	5.00%	50V		
C8869	1-162-964-11	CERAMIC CHIP	0.001UF	10.00%	50V		
< CONNECTOR >							
CN8600	* 1-817-037-61	PLUG, CONNECTOR	6P				
CN8601	* 1-816-980-71	PLUG, CONNECTOR	3P				
CN8611	* 1-785-270-12	PIN, DY CONNECTOR	(PC BOARD)				
CN8612	* 1-564-511-11	PLUG, CONNECTOR	8P				
CN8614	* 1-564-508-11	PLUG, CONNECTOR	5P				
CN8616	1-695-915-11	TAB (CONTACT)					
CN8620	1-764-333-11	PIN, CONNECTOR(PCB)	(V TYPE)10P				
CN8810	* 1-564-510-11	PLUG, CONNECTOR	7P				
< DIODE >							
D8102	8-719-081-97	DIODE	MMDL914T1				
D8103	8-719-081-97	DIODE	MMDL914T1				
D8104	8-719-081-97	DIODE	MMDL914T1				
D8105	8-719-081-97	DIODE	MMDL914T1				
D8107	8-719-081-97	DIODE	MMDL914T1				
D8108	8-719-921-40	DIODE	MTZJ-4.7C				
D8128	8-719-081-97	DIODE	MMDL914T1				
D8129	8-719-081-97	DIODE	MMDL914T1				
D8132	8-719-081-97	DIODE	MMDL914T1				
D8133	8-719-081-97	DIODE	MMDL914T1				
D8198	1-535-303-00	LEAD, JUMPER	(5.0MM)				
D8199	8-719-081-97	DIODE	MMDL914T1				
D8611	8-719-081-97	DIODE	MMDL914T1				
D8612	8-719-081-97	DIODE	MMDL914T1				
D8803	8-719-908-03	DIODE	GP08D				
D8805	8-719-302-43	DIODE	ELI2				
D8806	8-719-979-85	DIODE	EGP20G				
D8807	8-719-085-12	DIODE	BYV98-200-RAS	15/12			
D8808	8-719-085-12	DIODE	BYV98-200-RAS	15/12			
D8811	8-719-110-41	DIODE	RD15ESB2				
D8818	8-719-109-89	DIODE	RD5.6ESB2				
D8819	8-719-050-38	DIODE	M1MA152WK-T1				
D8820	8-719-081-97	DIODE	MMDL914T1				
D8851	8-719-970-87	DIODE	ERA38-06				
D8856	8-719-081-97	DIODE	MMDL914T1				
D8857	8-719-110-41	DIODE	RD15ESB2				
D8858	8-719-081-97	DIODE	MMDL914T1				
D8860	8-719-110-41	DIODE	RD15ESB2				
< FERRITE BEAD >							
FB8806	1-410-397-21	FERRITE			1.1UH		
FB8807	1-410-397-21	FERRITE			1.1UH		
< IC >							
IC8100	8-759-659-67	IC	LA6393DLL				
IC8101	8-759-659-67	IC	LA6393DLL				
IC8102	8-759-638-79	IC	NJM3404AD-W				
IC8103	8-759-659-67	IC	LA6393DLL				
< COIL >							
L8801	1-410-397-21	FERRITE			1.1UH		
L8802	1-410-397-21	FERRITE			1.1UH		
L8803	1-410-397-21	FERRITE			1.1UH		
L8805	1-408-947-00	INDUCTOR			2.2MH		
L8851	1-535-303-00	LEAD, JUMPER	(5.0MM)				
< INDUCTOR >							
LF8801	1-406-985-11	INDUCTOR			2.2MH		
LF8851	1-406-674-11	INDUCTOR			3.3MH		
< TRANSISTOR >							
Q8100	8-729-010-29	TRANSISTOR	MSD601-RST1				
Q8101	8-729-010-29	TRANSISTOR	MSD601-RST1				
Q8102	8-729-010-29	TRANSISTOR	MSD601-RST1				
Q8103	8-729-010-29	TRANSISTOR	MSD601-RST1				
Q8104	8-729-010-29	TRANSISTOR	MSD601-RST1				

REF.NO.	PART.NO	DESCRIPTION	REMARK	REF.NO.	PART.NO	DESCRIPTION	REMARK
Q8105	8-729-010-29	TRANSISTOR MSD601-RST1		R8113	1-216-833-11	METAL CHIP 10K 5%	1/10W
Q8106	8-729-010-29	TRANSISTOR MSD601-RST1		R8114	1-216-833-11	METAL CHIP 10K 5%	1/10W
Q8107	8-729-010-29	TRANSISTOR MSD601-RST1		R8115	1-216-845-11	METAL CHIP 100K 5%	1/10W
Q8108	8-729-010-05	TRANSISTOR MSB709-RT1		R8116	1-216-845-11	METAL CHIP 100K 5%	1/10W
Q8110	8-729-010-05	TRANSISTOR MSB709-RT1		R8117	1-216-833-11	METAL CHIP 10K 5%	1/10W
Q8112	8-729-010-29	TRANSISTOR MSD601-RST1		R8118	1-216-833-11	METAL CHIP 10K 5%	1/10W
Q8113	8-729-010-29	TRANSISTOR MSD601-RST1		R8119	1-216-833-11	METAL CHIP 10K 5%	1/10W
Q8115	8-729-010-05	TRANSISTOR MSB709-RT1		R8120	1-216-825-11	METAL CHIP 2.2K 5%	1/10W
Q8118	8-729-010-29	TRANSISTOR MSD601-RST1		R8121	1-216-825-11	METAL CHIP 2.2K 5%	1/10W
Q8119	8-729-010-05	TRANSISTOR MSB709-RT1		R8122	1-216-825-11	METAL CHIP 2.2K 5%	1/10W
Q8120	8-729-010-05	TRANSISTOR MSB709-RT1		R8123	1-216-841-11	METAL CHIP 47K 5%	1/10W
Q8122	8-729-010-05	TRANSISTOR MSB709-RT1		R8124	1-216-821-11	METAL CHIP 1K 5%	1/10W
Q8123	8-729-010-05	TRANSISTOR MSB709-RT1		R8125	1-216-825-11	METAL CHIP 2.2K 5%	1/10W
Q8125	8-729-010-29	TRANSISTOR MSD601-RST1		R8126	1-216-815-11	METAL CHIP 330 5%	1/10W
Q8126	8-729-010-05	TRANSISTOR MSB709-RT1		R8127	1-208-794-11	METAL CHIP 3.3K 0.5%	1/10W
Q8127	8-729-010-05	TRANSISTOR MSB709-RT1		R8128	1-208-822-11	METAL CHIP 47K 0.5%	1/10W
Q8128	8-729-010-29	TRANSISTOR MSD601-RST1		R8129	1-208-822-11	METAL CHIP 47K 0.5%	1/10W
Q8132	8-729-421-19	TRANSISTOR UN2213		R8130	1-208-846-11	METAL CHIP 470K 0.5%	1/10W
Q8135	8-729-010-29	TRANSISTOR MSD601-RST1		R8131	1-216-815-11	METAL CHIP 330 5%	1/10W
Q8136	8-729-010-05	TRANSISTOR MSB709-RT1		R8132	1-216-815-11	METAL CHIP 330 5%	1/10W
Q8137	8-729-010-29	TRANSISTOR MSD601-RST1		R8133	1-216-815-11	METAL CHIP 330 5%	1/10W
Q8201	8-729-010-29	TRANSISTOR MSD601-RST1		R8136	1-208-822-11	METAL CHIP 47K 0.5%	1/10W
Q8202	8-729-010-29	TRANSISTOR MSD601-RST1		R8137	1-208-822-11	METAL CHIP 47K 0.5%	1/10W
Q8203	8-729-010-05	TRANSISTOR MSB709-RT1		R8138	1-208-822-11	METAL CHIP 47K 0.5%	1/10W
Q8455	8-729-010-29	TRANSISTOR MSD601-RST1		R8139	1-208-822-11	METAL CHIP 47K 0.5%	1/10W
Q8801	8-729-048-47	TRANSISTOR 2SC2688 (5) -LK		R8140	1-216-825-11	METAL CHIP 2.2K 5%	1/10W
Q8802	8-729-048-47	TRANSISTOR 2SC2688 (5) -LK		R8141	1-208-814-91	METAL CHIP 22K 0.5%	1/10W
Q8803	8-729-056-16	TRANSISTOR 2SC5698-SONY-CA		R8142	1-208-803-11	METAL CHIP 7.5K 0.5%	1/10W
Q8804	8-729-056-17	TRANSISTOR 2SC5696-SONY-CA		R8143	1-216-825-11	METAL CHIP 2.2K 5%	1/10W
Q8805	8-729-050-48	TRANSISTOR IRF614-005		R8144	1-216-841-11	METAL CHIP 47K 5%	1/10W
Q8806	8-729-047-59	TRANSISTOR STP5NB40FP		R8145	1-216-825-11	METAL CHIP 2.2K 5%	1/10W
Q8807	8-729-421-19	TRANSISTOR UN2213		R8146	1-208-790-11	METAL CHIP 2.2K 0.5%	1/10W
Q8822	8-729-010-29	TRANSISTOR MSD601-RST1		R8149	1-216-828-11	METAL CHIP 3.9K 5%	1/10W
Q8823	8-729-424-08	TRANSISTOR UN2111		R8150	1-216-837-11	METAL CHIP 22K 5%	1/10W
Q8851	6-550-012-01	TRANSISTOR STP5NB40 (033Y)		R8153	1-216-295-91	SHORT CHIP 0	
< RESISTOR >				R8154	1-208-782-11	METAL CHIP 1K 0.5%	1/10W
R8100	1-216-813-11	METAL CHIP 220 5%	1/10W	R8155	1-208-789-11	METAL CHIP 2K 0.5%	1/10W
R8101	1-216-813-11	METAL CHIP 220 5%	1/10W	R8158	1-208-794-11	METAL CHIP 3.3K 0.5%	1/10W
R8102	1-216-825-11	METAL CHIP 2.2K 5%	1/10W	R8159	1-216-295-91	SHORT CHIP 0	
R8103	1-216-825-11	METAL CHIP 2.2K 5%	1/10W	R8160	1-216-295-91	SHORT CHIP 0	
R8104	1-216-825-11	METAL CHIP 2.2K 5%	1/10W	R8161	1-208-804-11	METAL CHIP 8.2K 0.5%	1/10W
R8105	1-216-821-11	METAL CHIP 1K 5%	1/10W	R8162	1-216-821-11	METAL CHIP 1K 5%	1/10W
R8106	1-216-825-11	METAL CHIP 2.2K 5%	1/10W	R8163	1-216-833-11	METAL CHIP 10K 5%	1/10W
R8107	1-208-792-11	METAL CHIP 2.7K 0.5%	1/10W	R8164	1-208-814-91	METAL CHIP 22K 0.5%	1/10W
R8108	1-208-792-11	METAL CHIP 2.7K 0.5%	1/10W	R8165	1-208-830-11	METAL CHIP 100K 0.5%	1/10W
R8109	1-208-814-91	METAL CHIP 22K 0.5%	1/10W	R8168	1-216-829-11	METAL CHIP 4.7K 5%	1/10W
R8110	1-208-814-91	METAL CHIP 22K 0.5%	1/10W	R8169	1-208-830-11	METAL CHIP 100K 0.5%	1/10W
R8111	1-216-825-11	METAL CHIP 2.2K 5%	1/10W	R8170	1-216-815-11	METAL CHIP 330 5%	1/10W
R8112	1-216-825-11	METAL CHIP 2.2K 5%	1/10W	R8171	1-216-825-11	METAL CHIP 2.2K 5%	1/10W
				R8174	1-216-834-11	METAL CHIP 12K 5%	1/10W

Note : The components identified by shading and marked Δ are critical for safety. Replace only with the part numbers specified in the parts list.

D

REF.NO.	PART.NO	DESCRIPTION	REMARK	REF.NO.	PART.NO	DESCRIPTION	REMARK
R8175	1-218-867-11	METAL CHIP	6.8K 0.5% 1/10W	R8817	1-216-361-00	METAL OXIDE	0.22 5% 2W
R8176	1-216-838-11	METAL CHIP	27K 5% 1/10W	R8818	1-249-405-11	CARBON	100 5% 1/4W
R8177	1-216-830-11	METAL CHIP	5.6K 5% 1/10W	R8819	1-247-807-31	CARBON	100 5% 1/4W
R8179	1-216-295-91	SHORT CHIP	0	R8831	1-260-124-11	CARBON	120K 5% 1/2W
R8180	1-216-825-11	METAL CHIP	2.2K 5% 1/10W	R8833	1-202-972-61	FUSIBLE	1 5% 1/4W
R8181	1-216-295-91	SHORT CHIP	0	R8834	1-260-288-11	CARBON	0.47 5% 1/2W
R8182	1-216-841-11	METAL CHIP	47K 5% 1/10W	R8835	1-260-288-11	CARBON	0.47 5% 1/2W
R8183	1-216-825-11	METAL CHIP	2.2K 5% 1/10W	R8836	1-249-432-11	CARBON	18K 5% 1/4W
R8186	1-216-827-11	METAL CHIP	3.3K 5% 1/10W	R8837	1-215-894-11	METAL OXIDE	2.2K 5% 2W
R8188	1-216-829-11	METAL CHIP	4.7K 5% 1/10W	R8838	1-214-905-11	METAL	47K 1% 1/2W
R8189	1-216-822-11	METAL CHIP	1.2K 5% 1/10W	R8839	1-215-894-11	METAL OXIDE	2.2K 5% 2W
R8190	1-216-825-11	METAL CHIP	2.2K 5% 1/10W	R8840	1-247-843-11	CARBON	3.3K 5% 1/4W
R8191	1-215-925-11	METAL OXIDE	22K 5% 3W	R8842	1-260-123-11	CARBON	100K 5% 1/2W
R8196	1-249-377-11	CARBON	0.47 5% 1/4W	R8843	1-216-833-11	METAL CHIP	10K 5% 1/10W
R8197	1-216-841-11	METAL CHIP	47K 5% 1/10W	R8844	1-216-829-11	METAL CHIP	4.7K 5% 1/10W
R8203	1-208-789-11	METAL CHIP	2K 0.5% 1/10W	R8845	1-216-829-11	METAL CHIP	4.7K 5% 1/10W
R8204	1-216-295-91	SHORT CHIP	0	R8851	1-260-123-11	CARBON	100K 5% 1/2W
R8205	1-216-295-91	SHORT CHIP	0	R8852	1-260-123-11	CARBON	100K 5% 1/2W
R8206	1-216-849-11	METAL CHIP	220K 5% 1/10W	R8853	1-260-123-11	CARBON	100K 5% 1/2W
R8207	1-216-846-11	METAL CHIP	120K 5% 1/10W	R8854	1-249-425-11	CARBON	4.7K 5% 1/4W
R8209	1-216-295-91	SHORT CHIP	0	R8856	1-216-485-11	METAL OXIDE	5.6K 5% 3W
R8210	1-216-825-11	METAL CHIP	2.2K 5% 1/10W	R8857	1-216-485-11	METAL OXIDE	5.6K 5% 3W
R8211	1-216-833-11	METAL CHIP	10K 5% 1/10W	R8858	1-215-922-11	METAL OXIDE	6.8K 5% 3W
R8212	1-216-825-11	METAL CHIP	2.2K 5% 1/10W	R8859	1-215-922-11	METAL OXIDE	6.8K 5% 3W
R8215	1-208-814-91	METAL CHIP	22K 0.5% 1/10W	R8865	1-216-829-11	METAL CHIP	4.7K 5% 1/10W
R8216	1-208-812-11	METAL CHIP	18K 0.5% 1/10W	R8866	1-216-295-91	SHORT CHIP	0
R8217	1-216-833-11	METAL CHIP	10K 5% 1/10W	R8867	1-216-829-11	METAL CHIP	4.7K 5% 1/10W
R8219	1-216-841-11	METAL CHIP	47K 5% 1/10W	R8869	1-216-837-11	METAL CHIP	22K 5% 1/10W
R8220	1-216-834-11	METAL CHIP	12K 5% 1/10W	R8870	1-216-837-11	METAL CHIP	22K 5% 1/10W
R8221	1-216-837-11	METAL CHIP	22K 5% 1/10W	R8885	1-208-854-11	METAL CHIP	1M 0.5% 1/10W
R8223	1-164-230-11	CERAMIC CHIP	220PF 5.00% 50V	R8886	1-208-836-11	METAL CHIP	180K 0.5% 1/10W
R8224	1-216-827-11	METAL CHIP	3.3K 5% 1/10W	R8887	1-216-841-11	METAL CHIP	47K 5% 1/10W
R8456	1-216-845-11	METAL CHIP	100K 5% 1/10W	R8888	1-249-441-11	CARBON	100K 5% 1/4W
R8457	1-216-834-11	METAL CHIP	12K 5% 1/10W	R8895	1-249-443-11	CARBON	0.47 5% 1/4W
R8458	1-216-841-11	METAL CHIP	47K 5% 1/10W	R8896	1-249-443-11	CARBON	0.47 5% 1/4W
R8459	1-216-825-11	METAL CHIP	2.2K 5% 1/10W	R8897	1-215-485-00	METAL	470K 1% 1/4W
R8800	1-247-895-91	CARBON	470K 5% 1/4W	R8898	1-215-493-00	METAL	1M 1% 1/4W
R8804	1-249-408-11	CARBON	180 5% 1/4W	R8899	1-215-493-00	METAL	1M 1% 1/4W
R8805	1-249-408-11	CARBON	180 5% 1/4W				
R8806	1-249-411-11	CARBON	330 5% 1/4W			< TRANSFORMER >	
R8807	1-249-411-11	CARBON	330 5% 1/4W	T8800	Δ 8-598-851-50	TRANSFORMER ASSY FLYBACK NX-4522//Z	
R8808	1-260-340-11	CARBON	10K 5% 1/2W	T8801	1-437-430-11	TRANSFORMER, FERRITE (HDT)	
R8809	1-260-340-11	CARBON	10K 5% 1/2W	T8802	1-437-430-11	TRANSFORMER, FERRITE (HDT)	
R8810	1-215-895-11	METAL OXIDE	3.3K 5% 2W	T8852	1-433-487-12	TRANSFORMER, FERRITE (DFT)	
R8811	1-215-896-00	METAL OXIDE	4.7K 5% 2W				
R8812	1-216-461-00	METAL OXIDE	5.6K 5% 2W				
R8813	1-215-895-11	METAL OXIDE	3.3K 5% 2W				
R8814	1-215-880-00	METAL OXIDE	10 5% 2W				
R8815	1-215-880-00	METAL OXIDE	10 5% 2W				
R8816	1-216-365-00	METAL OXIDE	0.47 5% 2W				



REF.NO.	PART.NO	DESCRIPTION	REMARK	REF.NO.	PART.NO	DESCRIPTION	REMARK
* A-1300-626-A VM Board Complete							
	4-382-854-01	SCREW (M3X8), P, SW (+)		Q7403	8-729-119-78	TRANSISTOR 2SC2785-HFE	
	< CAPACITOR >			Q7404	8-729-026-49	TRANSISTOR 2SA1037AK-T146-R	
C7401	1-126-935-11	ELECT	470UF 20.00% 16V	Q7405	8-729-026-39	TRANSISTOR 2SA933AS-QT	
C7403	1-104-655-91	ELECT	470UF 20.00% 6.3V	Q7406	8-729-045-05	TRANSISTOR 2SA2005	
C7404	1-115-339-11	CERAMIC CHIP	0.1UF 10.00% 50V	Q7407	8-729-045-04	TRANSISTOR 2SC5511	
C7405	1-126-933-11	ELECT	100UF 20.00% 16V				
C7406	1-104-655-91	ELECT	470UF 20.00% 6.3V	Q7408	8-729-026-49	TRANSISTOR 2SA1037AK-T146-R	
	< RESISTOR >			Q7409	8-729-010-29	TRANSISTOR MSD601-RST1	
C7407	1-107-364-11	MYLAR	0.01UF 10.00% 200V	R7400	1-216-017-91	RES-CHIP 47 5% 1/10W	
C7408	1-107-364-11	MYLAR	0.01UF 10.00% 200V	R7401	1-216-061-91	RES-CHIP 3.3K 5% 1/10W	
C7409	1-107-649-11	ELECT	2.2UF 20.00% 250V	R7402	1-216-041-00	RES-CHIP 470 5% 1/10W	
C7410	1-130-471-00	MYLAR	0.001UF 5.00% 50V	R7403	1-249-393-11	CARBON 10 5% 1/4W	
C7411	1-130-471-00	MYLAR	0.001UF 5.00% 50V	R7404	1-249-413-11	CARBON 470 5% 1/4W	
C7412	1-126-935-11	ELECT	470UF 20.00% 16V	R7405	1-216-065-91	RES-CHIP 4.7K 5% 1/10W	
C7413	1-126-935-11	ELECT	470UF 20.00% 16V	R7407	1-249-411-11	CARBON 330 5% 1/4W	
C7414	1-107-652-11	ELECT	10UF 20.00% 250V	R7409	1-216-029-00	RES-CHIP 150 5% 1/10W	
C7415	1-107-363-91	MYLAR	0.0068UF 10.00% 200V	R7410	1-216-017-91	RES-CHIP 47 5% 1/10W	
C7418	1-163-021-91	CERAMIC CHIP	0.01UF 10.00% 50V	R7411	1-216-017-91	RES-CHIP 47 5% 1/10W	
C7421	1-163-251-11	CERAMIC CHIP	100PF 5.00% 50V	R7412	1-216-017-91	RES-CHIP 47 5% 1/10W	
	< CONNECTOR >			R7413	1-249-414-11	CARBON 560 5% 1/4W	
CN7442	* 1-817-044-81	PLUG, CONNECTOR	7P	R7414	1-249-432-11	CARBON 18K 5% 1/4W	
CN7443	* 1-564-506-11	PLUG, CONNECTOR	3P	R7415	1-247-739-11	CARBON 100 5% 1/2W	
CN7444	* 1-770-747-11	CONNECTOR, BOARD TO BOARD	12P	R7416	1-249-389-11	CARBON 4.7 5% 1/4W	
	< DIODE >			R7417	1-249-432-11	CARBON 18K 5% 1/4W	
D7400	8-719-991-33	DIODE	1SS133T-77	R7418	1-249-414-11	CARBON 560 5% 1/4W	
D7401	8-719-991-33	DIODE	1SS133T-77	R7419	1-249-421-11	CARBON 2.2K 5% 1/4W	
D7402	1-535-303-00	LEAD, JUMPER	(5.0MM)	R7420	1-249-421-11	CARBON 2.2K 5% 1/4W	
D7403	8-719-991-33	DIODE	1SS133T-77	R7421	1-249-389-11	CARBON 4.7 5% 1/4W	
D7404	8-719-991-33	DIODE	1SS133T-77	R7422	1-249-405-11	CARBON 100 5% 1/4W	
D7405	8-719-924-11	DIODE	MTZJ-T-77-22	R7423	1-215-915-11	METAL OXIDE 470 5% 3W	
D7406	8-719-924-11	DIODE	MTZJ-T-77-22	R7427	1-216-025-11	RES-CHIP 100 5% 1/10W	
	< FERRITE BEAD >			R7428	1-216-033-00	RES-CHIP 220 5% 1/10W	
FB7400	1-535-303-00	LEAD, JUMPER	(5.0MM)	R7429	1-216-033-00	RES-CHIP 220 5% 1/10W	
FB7401	1-535-303-00	LEAD, JUMPER	(5.0MM)	R7432	1-216-065-91	RES-CHIP 4.7K 5% 1/10W	
	< COIL >			R7433	1-249-395-11	CARBON 15 5% 1/4W	
L7400	1-414-934-21	INDUCTOR	10UH	R7434	1-249-395-11	CARBON 15 5% 1/4W	
L7402	1-414-934-21	INDUCTOR	10UH	R7435	1-216-033-00	RES-CHIP 220 5% 1/10W	
L7403	1-414-934-21	INDUCTOR	10UH	R7436	1-216-049-11	RES-CHIP 1K 5% 1/10W	
	< TRANSISTOR >						
Q7400	8-729-010-29	TRANSISTOR	MSD601-RST1				
Q7401	8-729-010-29	TRANSISTOR	MSD601-RST1				
Q7402	8-729-010-29	TRANSISTOR	MSD601-RST1				

REF.NO.	PART.NO	DESCRIPTION	REMARK	REF.NO.	PART.NO	DESCRIPTION	REMARK
---------	---------	-------------	--------	---------	---------	-------------	--------

MISCELLANEOUS

△	1-571-433-21	SWITCH, PUSH (AC POWER)	
△	1-823-853-11	CORD, POWER	
	1-424-855-11	COIL, CHOKE 29MMH	
	8-598-623-10	TUNER FSS BTP-AC421	
△	1-453-340-41	TRANSFORMER ASSY, FLYBACK (NX-4522//Z2B4)	
	1-529-408-11	SPEAKER (4.2X24CM)	
	1-910-000-50	WOOFER LS	
△	8-451-504-31	DEFLECTION YOKE (Y29RSC-5)	
	1-452-896-11	COIL, NA ROTATION (RT200)	
△	8-453-021-21	NECK ASSY, (NA-2919-M2)	
△	1-424-888-11	COIL, DEGAUSSING	
△	1-251-946-11	CAP ASSY, HIGH-VOLTAGE	
△	8-735-097-05	PICTURE TUBE (M68LNH060X)	
	1-452-094-00	MAGNET, ROTATABLE DISK; 15MM Ø	
	1-425-032-00	MAGNET, DISK; 10MM Ø	

ACCESSORIES AND PACKAGING MATERIALS

*4-102-972-01	INDIVIDUAL CARTON
*4-102-973-01	CUSHION UPPER
*4-102-974-01	CUSHION LOWER
4-395-957-01	BAG, PROTECTION
2-024-605-11	INSTRUCTION MANUAL (GERMAN/TURKISH/GREEK) (KV-29XL71E)
2-024-605-21	INSTRUCTION MANUAL (ITALIAN) (KV-29XL71E)
2-024-605-31	INSTRUCTION MANUAL (NORWEGIAN/PORTUGUESE/ SWEDISH/FINNISH/SPANISH/DANISH) (KV-29XL71E)
2-024-605-41	INSTRUCTION MANUAL (HUNGARIAN/CZECH/ENGLISH/ POLISH/RUSSIAN/BULGARIAN) (KV-29XL71K)
4-103-137-11	INSTRUCTION MANUAL (GERMAN/TURKISH/GREEK) (KV-29XL70E)
4-103-137-21	INSTRUCTION MANUAL (ITALIAN) (KV-29XL70E)
4-103-137-31	INSTRUCTION MANUAL (NORWEGIAN/PORTUGUESE/ SWEDISH/FINNISH/SPANISH/DANISH) (KV-29XL70E)
4-103-137-41	INSTRUCTION MANUAL (HUNGARIAN/CZECH/ENGLISH/ POLISH/RUSSIAN/BULGARIAN) (KV-29XL70K)

REMOTE COMMANDER

1-476-700-12	REMOTE COMMANDER (RM-934) (KV-29XL71)
1-478-654-11	REMOTE COMMANDER (RM-944) (KV-29XL70)

TRACE

A new TV Repair Assistance Tool that combines ease of use and powerful PC software tools to allow you to save valuable time during many TV repairs.



The TRACE interface connects to the PC's serial port. It provides connection to the TV's I²C bus and can be provided with an InfraRed transmitter (optional).

The interface is powered by a standard 9 V PP3 battery for portable use, and can also be powered by an external 9V/25mA DC power supply.

The TRACE software that is supplied with the interface allows you to:

- Read, restore and compare NVM contents via the I²C bus
- Acknowledge check of all I²C devices in the TV set
- Read Error Codes (emulation of the Error Reader tool)

With the optional IR Add-on kit, the following features can be added:

- Remote Commander emulation
- User programmable Functional Check through Infrared
- Fast and documented Test Mode setting of all Sony TV chassis

Additional features such as Adjustments and Troubleshooting are available in chassis-dependent software modules. Please contact your local Sony Service organisation for the latest information.

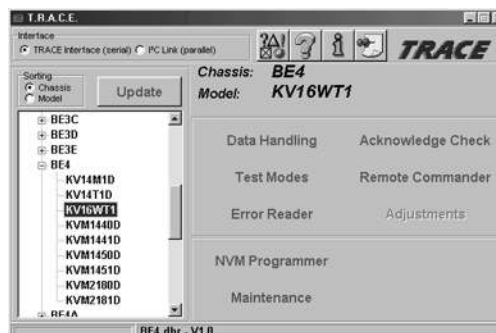

Note: For workshops already using the existing I²C Link parallel port interface (9-948-320-30), this software can be used as well, replacing the TV Data Handling software (9-948-340-50), but Error Reader and IR functions can only be accessed with the TRACE interface.

Partnumbers: TRACE Starter Kit (TRACE interface + software): 9-948-320-70
TRACE Software (for users of the I²C Link interface): 9-948-340-80
TRACE IR Add-on (IR interface + Remote Commander software): 9-948-320-80

PC requirements: IBM-compatible PC with operating system Windows95, Windows98, or WindowsNT*.

* WindowsNT only supported with TRACE interface

Sony Corporation
Sony UK
Service Promotions Dept.

English
04DP7100-1
Printed in U.K.
© 2004.4